



User Guide

Quality, Design and Innovation



home.liebherr.com/fridge-manuals









LIEBHERR

General safety instructions

Contents

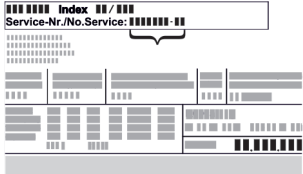
1	General safety instructions.....	2
2	Appliance at a glance.....	3
2.1	Scope of delivery.....	3
2.2	Overview of the appliance and equipment.....	4
2.3	SmartDevice.....	4
2.4	Appliance range of use.....	4
2.5	Conformity.....	4
2.6	Spare parts.....	5
3	Functionality of the Touch & Swipe display.....	5
3.1	Navigation and symbol explanation.....	5
3.2	Menus.....	5
3.3	Sleep mode.....	5
4	Putting into operation.....	5
4.1	Switching on appliance (first use).....	5
5	Storage.....	6
5.1	Information regarding storage.....	6
5.2	Storage sketch.....	6
6	Saving energy.....	6
7	Controls.....	6
7.1	Control and display elements.....	6
7.1.1	Status display.....	7
7.1.2	Display symbols.....	7
7.1.3	Acoustic signals.....	7
7.2	Appliance functions.....	7
7.2.1	Notes on the appliance functions.....	7
7.2.2	Switching appliance on and off	7
7.2.3	WiFi	7
7.2.4	Temperature	8
7.2.5	Temperature unit	9
7.2.6	SabbathMode	9
7.2.7	HumiditySelect	9
7.2.8	Presentation light *.....	10
7.2.9	Display brightness	10
7.2.10	Door alarm	11
7.2.11	Light alarm	11
7.2.12	Alarm tone	11
7.2.13	Key tone	12
7.2.14	Display lock	12
7.2.15	Access codes.....	12
7.2.16	Language	13
7.2.17	Appliance and software information	13
7.2.18	Reminder	14
7.2.19	Demo mode	14
7.2.20	Resetting to factory settings	15
7.3	Message.....	15
7.3.1	Warnings.....	15
7.3.2	Reminders.....	16
8	Features.....	16
8.1	Wooden grid.....	16
8.2	Labels.....	18
9	Maintenance.....	18
9.1	FreshAir activated carbon filter.....	18
9.2	Cleaning the appliance.....	19
10	Customer help.....	19
10.1	Technical specifications.....	19
10.2	Operating noises.....	19
10.3	Technical fault.....	20
10.4	Customer Service.....	21
10.5	Model plate.....	21
11	Shutting down.....	21

The manufacturer is continually working on the further development of all types and models. Please be aware that we reserve the right to make changes to the shape, equipment and technology.

Symbol	Explanation
	Read instructions Please read the information in these instructions carefully to understand all of the benefits of your new appliance.
	Additional information on the Internet The digital manual with additional information can be found via the QR code on the front of the manual or by entering the service number at home.liebherr.com/fridge-manuals . The service number can be found on the serial tag:  <i>Fig. Example illustration</i>
	Check appliance Check all parts for transport damage. If you have any complaints, please contact your agent or customer service.
	Differences These instructions apply to a range of models, so differences are possible. Sections that apply to certain models only are marked with an asterisk (*).
	Instructions and results Instructions are marked with a ▶. Results are marked with a ▷.
	Videos Videos about the appliances are available on the YouTube channels of Liebherr-Hausgeräte.

Open source licences:

The appliance contains software components that use open source licences. Information on the open source licences used can be found here: home.liebherr.com/open-source-licences

These operating instructions apply to:

UWpr 3662

1 General safety instructions

Please keep these instructions in a safe place and pass them on to any subsequent owners.

Read these operating instructions carefully before use to ensure safe and correct use of the appliance. Follow the instructions, safety instructions and warning messages included at all times. They are important for ensuring you can operate and install the appliance safely and without any problems.

Danger for the user:

- This device can be used by children and people with impaired physical, sensory or mental abilities or with a lack of experience and knowledge provided that they are supervised or have received instruction in the safe use of this device, and about the resulting hazards. Children must not play with this appliance. Cleaning and user maintenance work must not be carried out by chil-

dren without adult supervision. Children aged between 3 and 8 are allowed to load and unload the appliance. Children below the age of 3 must be kept away from the appliance unless they are under continuous adult supervision.

- The socket must be easily accessible so that the appliance can be disconnected quickly from the electricity in an emergency. It must not be located in the area behind the appliance.
- When disconnecting the appliance from the supply, always take hold of the plug. Do not pull the cable.
- In the event of a fault pull out the mains plug or deactivate the fuse.
- Do not damage the mains power cable. Do not operate the appliance with a defective mains power cable.
- If the supply cord is damaged, it must be replaced by a special cord or assembly available from the manufacturer or its service agent.
- Only customer service or other specially trained staff may repair or perform other operations on the appliance.
- Only install, connect and dispose of the appliance according to the instructions.
- Only use the appliance when is installed.
- Special lights, such as LED lights on the appliance, are used to illuminate the interior of the appliance and are not suitable for room lighting.

Fire hazard:

- This appliance contains a refrigerant which is environmentally friendly, but flammable. Leaking refrigerant may ignite. It is hazardous for anyone other than an Authorised Service Person to service this appliance. In Queensland, the authorised Service Person MUST hold a Gas Work Authorisation for hydrocarbon refrigerants, to carry out Servicing or repairs where the gas system is being opened or charged.
- The coolant used (information on the model plate) is ecofriendly but also flammable. Any leaking coolant may ignite.
 - Do not damage the refrigerant circuit pipes.
 - Do not handle ignition sources inside the appliance.
 - Do not use electrical appliances inside the appliance (e.g. steam cleaners, heaters, ice cream makers, etc.).
 - If the refrigerant leaks: remove any naked flames or ignition sources from the vicinity of the leakage point. Properly air the room. Inform customer services.
- Do not store explosives or sprays using combustible propellants such as butane, propane, pentane, etc. in the appliance. To identify these spray cans, look for the list of contents printed on the can, or a flame symbol. Gases possibly escaping may ignite due to electrical components.
- Keep burning candles, lamps and other items with naked flames away from the appliance so that they do not set the appliance on fire.
- **WARNING:** Keep ventilation openings, in the appliance enclosure or in the built-in structure, clear of obstruction.
- **WARNING:** Do not use mechanical devices or other means to accelerate the defrosting process, other than those recommended by the manufacturer.
- **WARNING:** Do not damage the refrigerant circuit.
- Please be sure to store alcoholic drinks or other packaging containing alcohol in tightly closed containers. Any alcohol that leaks out may be ignited by electrical components.

Danger of tipping and falling:

- Do not misuse the plinth, drawers, doors etc. as a step or for support. This applies particularly to children.

Danger of food poisoning:

- Do not consume food which has been stored too long.

Danger of frostbite, numbness and pain:

- Avoid prolonged skin contact with cold surfaces or refrigerated/frozen goods or take protective measures, e.g wear gloves.
- Do not consume ice cream, water ice or ice cubes immediately and do not consume them too cold.

Danger of injury and damage:

- Hot steam can lead to injury. Do not use electrical heating or steam cleaning equipment, open flames or defrosting sprays to defrost.
- Do not use sharp implements to remove the ice.

Risk of crushing:

- Do not hold the hinge when opening and closing the door. Fingers may get caught.

Symbols on the appliance:



This symbol may be located on the compressor. It relates to the oil in the compressor and makes reference to the risk that: Swallowing or inhaling can be fatal. This advice is only relevant to recycling. There is no danger in normal operation.



This symbol is located on the compressor and indicates the danger of flammable materials. Do not remove the sticker.



This or a similar sticker may be located on the rear of the appliance. This sticker indicates that there are vacuum insulation panels (VIP) or perlite panels in the door and/or housing. This advice is only relevant to recycling. Do not remove the sticker.

Please note the warning messages and other specific advice in the other chapters:

	DANGER	indicates an immediately hazardous situation which will lead to death or serious injuries if it is not avoided.
	WARNING	indicates a hazardous situation which may lead to death or serious injuries if it is not avoided.
	CAUTION	indicates a hazardous situation which may lead to minor or moderate injuries if it is not avoided.
	NOTICE	indicates a hazardous situation which may lead to damage to property if it is not avoided.
	Note	indicates useful instructions and tips.

2 Appliance at a glance

2.1 Scope of delivery

Check all parts for transport damage. Contact your dealer or customer service in the event of complaints. (see 10.4 Customer Service)

Your new appliance comes with the following parts:

- Built-in appliance
- Features (depending on the model)
- Installation materials (depending on the model)

Appliance at a glance

- "Quick Start Guide"
- "Installation Guide"

2.2 Overview of the appliance and equipment

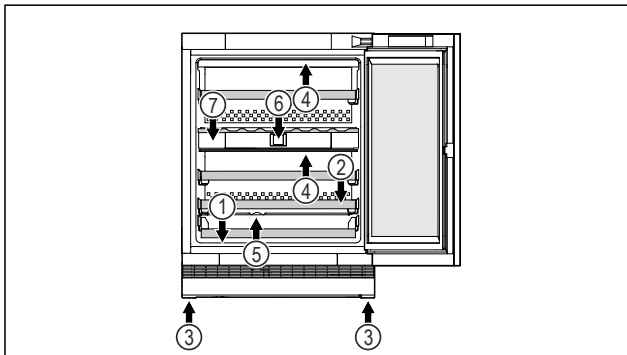

Fig. 1 Example illustration, front end

Equipment

- | | |
|------------------------|--------------------------------------|
| (1) Type plate | (5) Condensation drainage |
| (2) Shelves | (6) Controls and temperature display |
| (3) Adjustable foot | (7) FreshAir activated carbon filter |
| (4) Interior lighting* | |

2.3 SmartDevice

SmartDevice is the networking solution for your wine storage cabinet.

If your appliance SmartDevice-enabled or compatible, you can quickly and easily connect your appliance to your WiFi. With the SmartDevice app, you can operate your appliance from a mobile device. Additional functions and setting options are available in the SmartDevice SmartDevice app.

SmartDevice-enabled appliance:*

Your appliance is capable of being a SmartDevice. To be able to connect your device to WiFi, you need to download the SmartDevice app.*

SmartDevice-compatible appliance:*

Your appliance is compatible for use with the SmartDeviceBox. You must first purchase and install the SmartDeviceBox. In order to connect your appliance to the WiFi, you need to download the SmartDevice app.*

More information about SmartDevice:

smartdevice.liebherr.com

Purchasing the SmartDeviceBox in the Liebherr-Hausgeräte store:*

home.liebherr.com/shop/de/deu/smartdevicebox.html*

Downloading the SmartDevice app:



After installing and configuring the SmartDevice app, you can connect your appliance to your Wi-Fi (see 7.2.3 WiFi) using the SmartDevice app and the appliance's Wi-Fi function.

Note

The SmartDevice function is not available in the following countries: Russia, Belarus, Kazakhstan.

You cannot use the SmartDeviceBox.*

2.4 Appliance range of use

Intended use

The appliance is only suitable for storing wine in a domestic or domestic-like environment. This includes, for example, using

- in staff kitchens, bed and breakfast establishments,
- by guests in country houses, hotels, motels and other accommodation,
- for catering and similar services in the wholesale trade.

The appliance is not suitable for freezing food;

The appliance is suitable for integrating under counters.

All other types of use are not permitted.

Foreseeable misuse

The following applications are expressly forbidden:

- Storing and refrigerating medicines, blood plasma, laboratory preparations or similar substances and products based on the Medical Device Directive 2007/47/EC
- Use in outdoor areas with very high humidity
- Use in areas at risk of explosions

Misusing the appliance may lead to damage to the goods stored or they may spoil.

Climate classifications

Depending on the climate classification the appliance is designed to operate in restricted ambient temperatures. The climate classification applying to your appliance is printed on the rating plate.

Note

- Keep to the specified ambient temperatures in order to guarantee that the appliance works properly.

Climate classification	for ambient temperatures of
SN	10 °C to 32 °C
N	16 °C to 32 °C
ST	16 °C to 38 °C
T	16 °C to 43 °C
SN-ST	10 °C to 38 °C
SN-T	10 °C to 43 °C

2.5 Conformity

The refrigerant circuit has been tested for leaks. When installed, the appliance complies with the applicable safety regulations and with the corresponding directives.

For the EU market:*

The appliance complies with directive 2014/53/EU.*

For the GB market:*

The appliance complies with Radio Equipment Regulations 2017 SI 2017 No. 1206.*

The full text of the EU Declaration of Conformity is available on the following website: www.Liebherr.com

2.6 Spare parts







The spare parts availability for functional parts and stockable parts of the equipment is 15 years.

3 Functionality of the Touch & Swipe display

You operate your appliance using the Touch & Swipe display. You select appliance functions in the Touch & Swipe display (hereafter referred to as display) by tapping them. If you do not perform any action on the display for 10 seconds, the display either jumps back to the higher-level menu or directly to the status display.

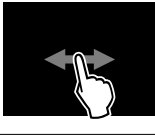
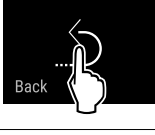
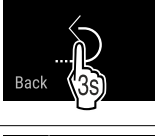
3.1 Navigation and symbol explanation

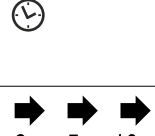
In the illustrations, different symbols are used to navigate the display. The following table describes these symbols.

Symbol	Description
	Briefly touch the display: Activates/deactivates function. Confirms selection. Opens submenu.
	Touch the display for a specified time (e.g. 3 seconds): Activates/deactivates function or value.
	Swipe left or right: Navigate in the menu.
	Briefly touch the Back symbol: Jumps back one menu level.
	Press and hold the Back symbol for 3 seconds: Jumps back to the status display.
	Briefly touch the Back symbol at the top left: Jumps back one menu level.
	Arrow with clock: It takes more than 10 seconds for the following message to appear in the display.
	Arrow with a time indication: It takes the specified amount of time until the following message appears in the display.
	"Open Settings menu" symbol: Navigates to the Settings menu and opens the settings menu. If necessary: Navigate to the desired function in the Settings menu. (see 3.2.1 Opening the Settings menu)

Symbol	Description
No action for 10 seconds	If you do not perform any action on the display for 10 seconds, the display either jumps back to the higher-level menu or directly to the status display.
Close the door and open it again.	If you close the door and immediately open it again, the display jumps directly back to the status display.

Note: Illustrations of the display are shown in the English version.

3.2 Menus

The appliance functions are distributed over various menus:

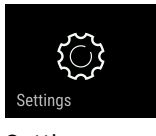
Menu	Description
Main menu	When you switch the appliance on, you are automatically in the main menu. From here you can navigate to the most important appliance functions, to the Settings menu and to the Advanced menu.
 Settings menu	The Settings menu contains additional appliance functions for setting up your appliance.

3.2.1 Opening the Settings menu

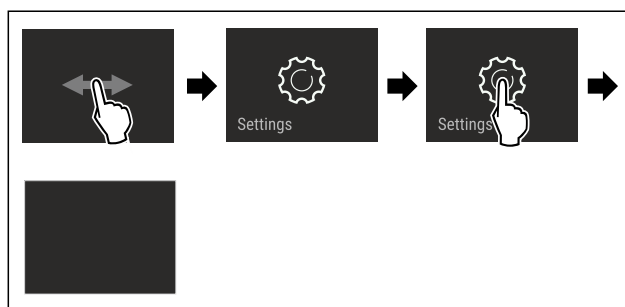

Fig. 2 Example illustration

- ▶ Carry out action steps according to the illustration.
- ▶ Settings menu is open.
- ▶ If necessary: Navigate to the desired function.

3.3 Sleep mode

If you do not touch the display for 1 minute, the display switches to sleep mode. In sleep mode, the display brightness is dimmed.

3.3.1 Ending sleep mode

- ▶ Touch the display briefly with your finger.
- ▶ Sleep mode is ended.

4 Putting into operation

4.1 Switching on appliance (first use)

Ensure that the following requirements are met:

- Appliance is installed and connected.
- All adhesive strips, adhesive and protective films and transport locks are removed from inside and outside the appliance.

Storage

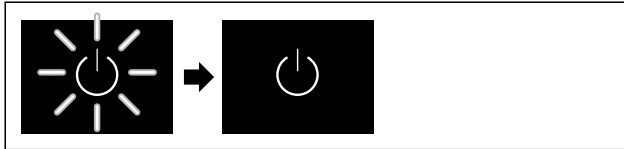

Fig. 3 Example illustration

- ▶ The standby symbol is flashing: Wait until the start process is complete.
- ▶ The display shows the standby symbol.

If the appliance is delivered with factory settings, the screen language must first be set during commissioning.

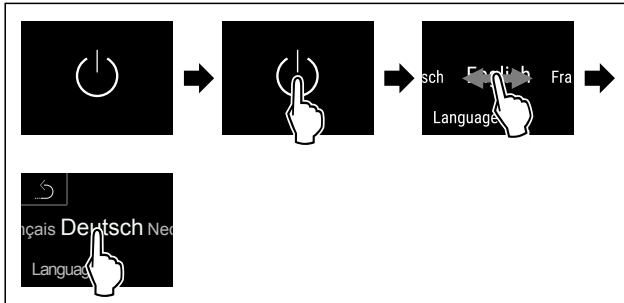

Fig. 4

- ▶ Carry out action steps according to the illustration.
- ▶ Language is set.

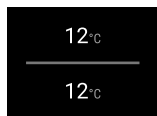

Fig. 6 Status display

- ▶ The appliance is ready for operation once the temperature appears in the display.
- ▶ The temperature display flashes until the set temperature is reached.

5 Storage

5.1 Information regarding storage



WARNING

Fire hazard from electrical appliances!
If you use electrical appliances in the food area of your appliance, they can cause a fire.

- ▶ Do not use electrical appliances in the food area of the appliance unless recommended by the manufacturer.

Note

The energy consumption increases and the cooling power goes down if ventilation is not sufficient.

- ▶ Always keep air slots clear.

Observe the following specifications for storage:

- Keep the air vents on the fan free.

5.2 Storage sketch

5.2.1 UWpr 3662

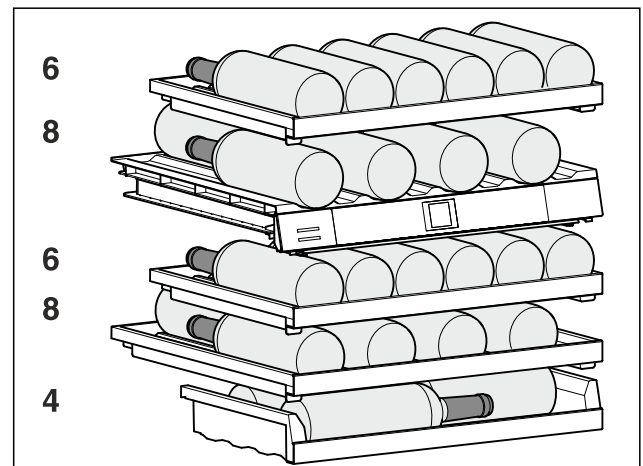

Fig. 7 Total 32 bottles (0.75 l Bordeaux bottles as per standard NF H 35-124)

6 Saving energy

- Pay attention to good ventilation. Do not cover ventilation holes or grids.
- Always keep the fan air slits clear.
- Do not install the appliance in direct sunlight or near radiators or similar sources of heat.
- If the appliance is installed directly next to an oven, the energy consumption may increase slightly. This is dependent on the service life and usage intensity of the oven.
- Energy consumption depends on the installation conditions, e.g. the ambient temperature (see 2.4 Appliance range of use) . A warmer ambient temperature can increase the energy consumption.
- Open the appliance for as short a time as possible.
- The lower the temperature is set the higher the energy consumption.

7 Controls

7.1 Control and display elements

The display provides a quick overview of the current appliance status, the temperature setting, the status of functions and settings as well as alarm and error messages.

Operation takes place directly on the Touch & Swipe display by swiping and touching.

Functions can be activated or deactivated and setting values can be changed.

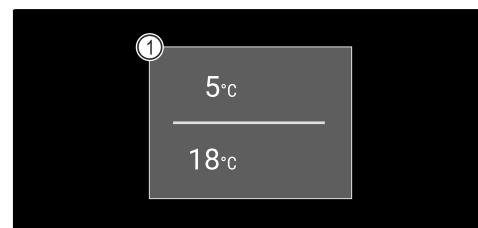

Fig. 8 Touch & Swipe display

- (1) Status display

7.1.1 Status display

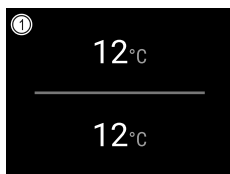

Fig. 9 Status display

(1) Temperature

The status display is the output display.

Navigation to the functions takes place from the status display.

7.1.2 Display symbols

Display symbols provide information about the status of the appliance.

Symbol	Appliance status
	Standby symbol Appliance is switched off.
	Standby symbol (flashing) Appliance is starting up.
	Temperature (flashing) Target temperature not yet reached. Appliance cooling to temperature set.
	D in the display The appliance is in demo mode.
	Error symbol (red) Appliance is in error state.
	Background (blue) Active setting or active function
	Bar (increasing) Press for 3 seconds to activate the setting.
	Bar (decreasing) Press for 3 seconds to deactivate the setting.

Symbols on the status display

7.1.3 Acoustic signals

A signal sounds in the following cases:

- If a function or a value is confirmed.
- If a function or a value can either not be activated or not deactivated.
- As soon as an error occurs.
- If there is an alarm message.

The alarms can be switched on and off in the customer menu.

7.2 Appliance functions

7.2.1 Notes on the appliance functions

The appliance functions are set at the factory so that your appliance is fully functional.

Before you alter, activate or deactivate the device functions, make sure that the following requirements are met:

- ❑ You have read and understood the descriptions of how the display works. (see 3 Functionality of the Touch & Swipe display)
- ❑ You have familiarised yourself with the operating and display elements of your appliance. (see 7.1 Control and display elements)

7.2.2 Switching appliance on and off



This function makes it possible to switch the entire appliance on and off.

Switching on appliance



Fig. 10

- ▶ Carry out action steps according to the illustration.

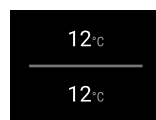

Fig. 12 Status display

- ▶ The temperature appears in the display.

Switching off appliance



Fig. 13

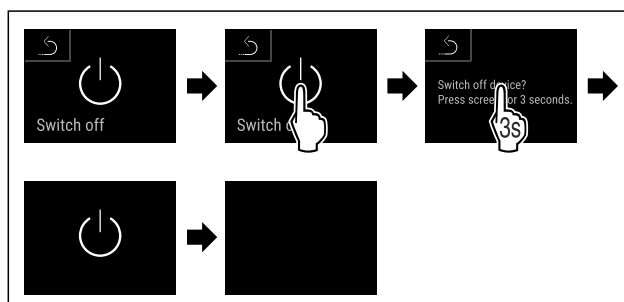

Fig. 14

- ▶ Carry out action steps according to the illustration.
- ▶ Standby symbol is shown in the display.
- ▶ The display switches off automatically after around 10 minutes.

7.2.3 WiFi



Use this function to connect your appliance to WiFi. You can then operate it via the SmartDevice app on a mobile device. You can also use this function to disconnect or reset the WiFi connection.

- ▶ Tap the temperature of the desired zone.

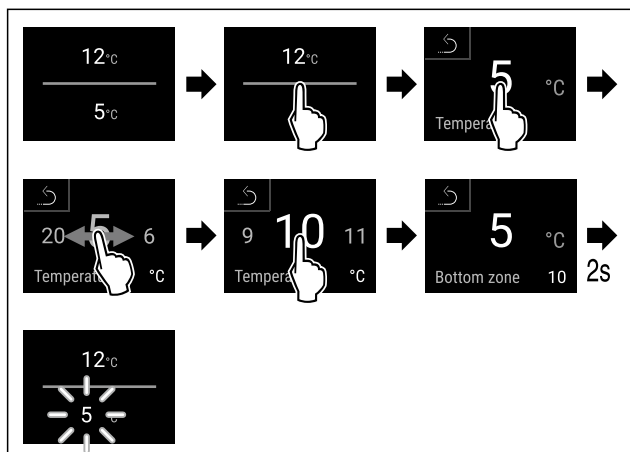

Fig. 24

- ▶ Carry out action steps according to the illustration.
- ▶ Temperature is set.

7.2.5 Temperature unit



Use this function to set the temperature unit. You can set degrees Celsius or degrees Fahrenheit as the temperature unit.

Setting the temperature unit

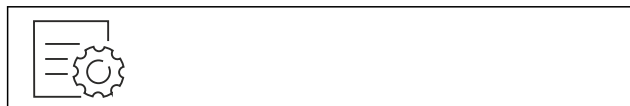

Fig. 25

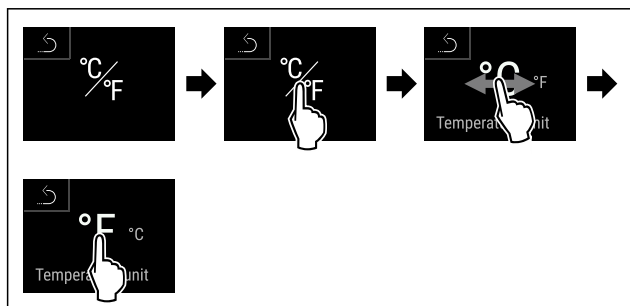

Fig. 27 Example illustration: Switch from degrees Celsius to degrees Fahrenheit.

- ▶ Carry out action steps according to the illustration.
- ▶ The temperature unit is set.

7.2.6 SabbathMode



You can use this function to activate or deactivate SabbathMode. If you activate this function, some electronic functions are switched off. As a result, your device meets the religious requirements for Jewish holidays such as Sabbath and complies with STAR-K Kosher certification.

Device status when SabbathMode is active
The status display shows SabbathMode permanently.
All functions on the display are locked except for the Deactivate SabbathMode function.
Active functions remain active.
The display remains bright when you close the door.

Device status when SabbathMode is active

The interior lighting is deactivated.
Reminders are not implemented. The set time interval stops.
Reminders and warnings are not displayed.
There is no door alarm.
There is no temperature alarm.
The InfinitySpring is switched off.
After a power failure, the appliance returns to SabbathMode.

Device status

Note

This appliance has certification from the “Institute for Science and Halacha”. (www.machonhalacha.co.il) You can find a list of STAR-K-certified appliances at www.star-k.org/appliances.

Activating SabbathMode

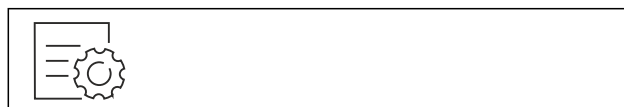

Fig. 28

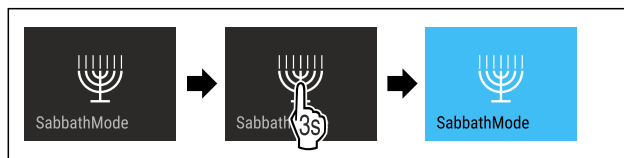

Fig. 29

- ▶ Carry out action steps according to the illustration.
- ▶ SabbathMode is activated.
- ▶ The status display shows SabbathMode permanently.

Deactivating SabbathMode

The SabbathMode is automatically deactivated after 80 hours. However, you can also deactivate SabbathMode manually at any time:

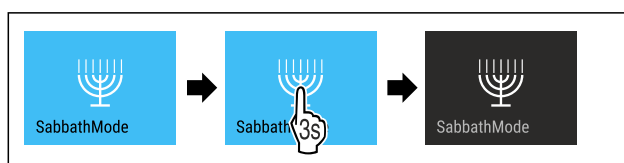
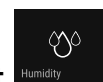

Fig. 30

- ▶ Carry out action steps according to the illustration.
- ▶ SabbathMode is deactivated.

7.2.7 HumiditySelect



Use this function to set the humidity inside your appliance. Setting the humidity correctly will have a positive effect on the structure of the corks during long-term storage and prevent them from drying out.

Note

The frequency and duration for which the door is open influence the humidity in the appliance.

You can choose between two humidity settings:

Controls

HumiditySelect function	Temperature setting on the appliance	Application/energy consumption
Standard (preset)	10-12 °C	average humidity in the environment between 50-80% low energy consumption of the appliance
High	10-12 °C	average humidity in the environment < 50% energy consumption of the appliance increases

Increasing the humidity in the appliance



Fig. 31

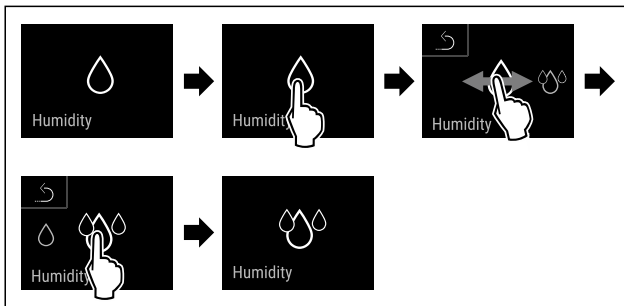

Fig. 32

- ▶ Carry out action steps according to the illustration.
- ▷ Humidity in the appliance increases.

Setting the humidity in the appliance to standard



Fig. 33

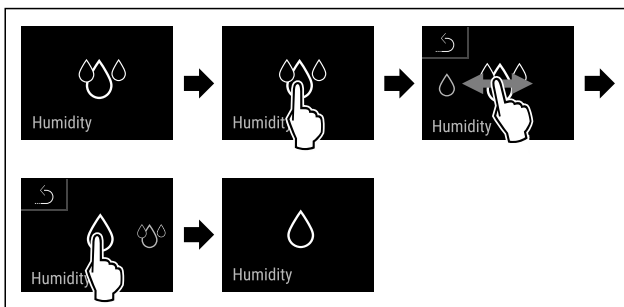

Fig. 34

- ▶ Carry out action steps according to the illustration.
- ▷ Humidity in the appliance decreases.

7.2.8 Presentation light



Use this function to set the interior lighting.

The following brightness levels can be set:

- Off

- 20%
- 40%
- 60%
- 80%
- 100% (default)

Setting the lighting



Fig. 35

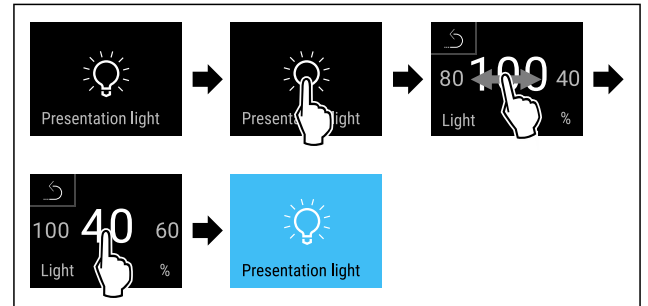

Fig. 36 Example illustration: Switch from 100% to 40%

- ▶ Carry out action steps according to the illustration.
- ▷ The brightness is set.

7.2.9 Display brightness



Use this function to set the display brightness in stages.

You can select the following brightness levels:

- 20 %
- 40 %
- 60 %
- 80 %
- 100 % (pre-setting)

Setting the brightness

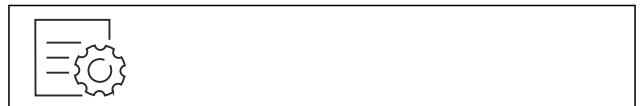

Fig. 37

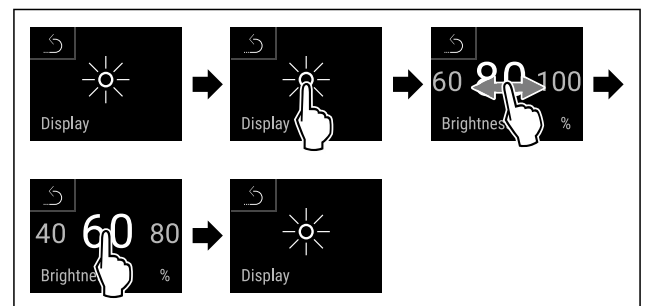

Fig. 38 Example illustration: Switch from 80 % to 60 %.

- ▶ Carry out action steps according to the illustration.
- ▷ The brightness is set.

7.2.10 Door alarm



Use this function to activate or deactivate the door alarm. The door alarm sounds if the door is open for too long. The door alarm is activated on delivery. You can set how long the door may be open before the door alarm sounds.

The following values can be set:

- 1 minute
- 2 minutes
- 3 minutes
- Off

Setting the door alarm



Fig. 39

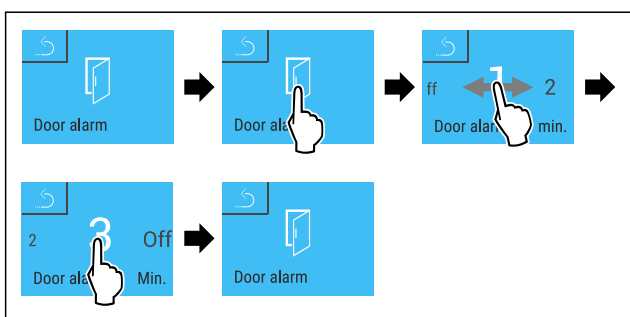

Fig. 40 Example illustration: Change door alarm from 1 minute to 3 minutes.

- ▶ Carry out action steps according to the illustration.
- ▶ The door alarm is set.

Deactivating the door alarm



Fig. 42

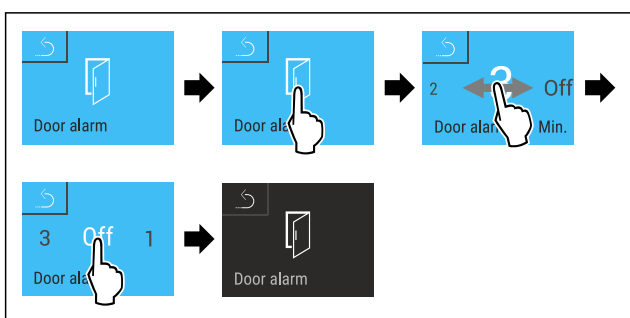

Fig. 43

- ▶ Carry out action steps according to the illustration.
- ▶ The door alarm is deactivated.

7.2.11 Light alarm



This setting allows the visual alarm messages in the display to also be emphasised by flashing appliance lighting.

Activating light alarm



Fig. 44

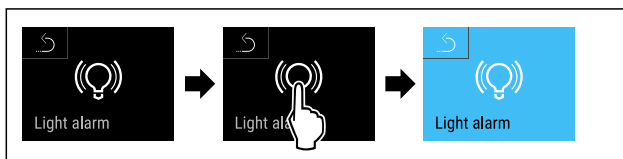

Fig. 45

- ▶ Carry out action steps according to the illustration.
- ▶ The light alarm is activated.

Deactivating light alarm



Fig. 46

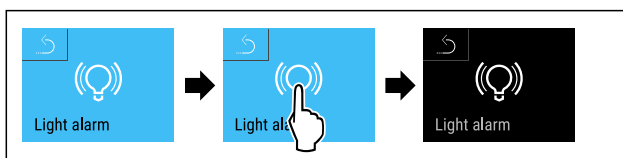

Fig. 47

- ▶ Carry out action steps according to the illustration.
- ▶ The light alarm is deactivated.

7.2.12 Alarm tone



This function enables all alarm sounds, such as door alarms, to be switched on and off.

Activating the alarm tone

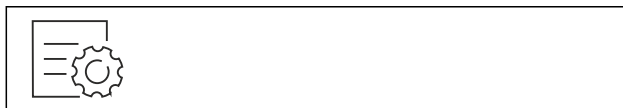

Fig. 48



Fig. 49

- ▶ Carry out action steps according to the illustration.
- ▶ The alarm tone is activated.

Deactivating the alarm tone



Fig. 50

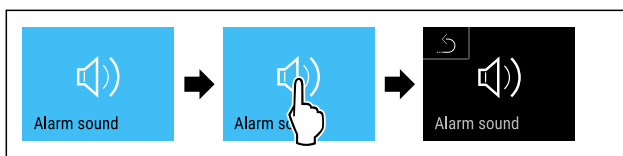

Fig. 51

Controls

- ▶ Carry out action steps according to the illustration.
- ▶ The alarm tone is deactivated.



7.2.13 Key tone

This function makes it possible to switch all button sounds, confirmation sounds, and the startup sound on and off.

Activating the key tone



Fig. 52

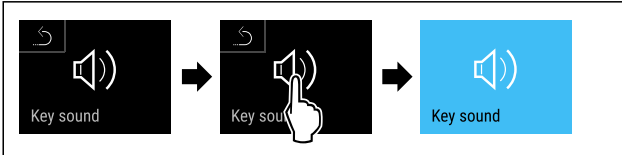

Fig. 53

- ▶ Carry out action steps according to the illustration.
- ▶ The key tone is activated.

Deactivating the key tone



Fig. 54

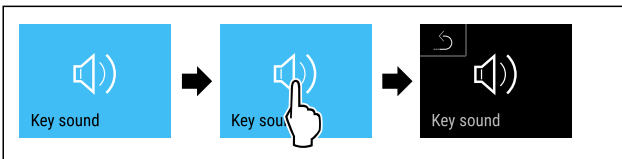

Fig. 55

- ▶ Carry out action steps according to the illustration.
- ▶ The key tone is deactivated.



7.2.14 Display lock

This setting avoids accidental operation of the appliance.

Application:

- Prevent settings and functions being changed unintentionally.
- Prevent appliance being switched off unintentionally.
- Prevent temperature being set unintentionally.

Activating the display lock



Fig. 56

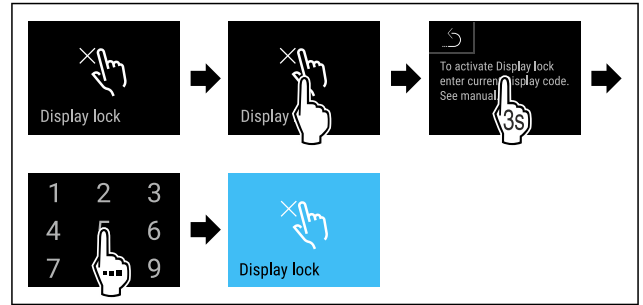

Fig. 57

- ▶ Carry out action steps according to the illustration.
- ▶ The display lock is activated.
- ▶ The status display appears.

Unlocking the display lock for a short time

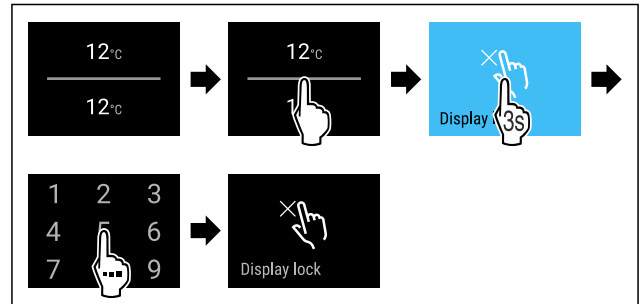

Fig. 58

- ▶ Carry out action steps according to the illustration.
- ▶ The display lock is deactivated.
- ▶ The status display appears.

Deactivating the display lock

- ▶ Carry out action steps (see Unlocking the display lock for a short time).

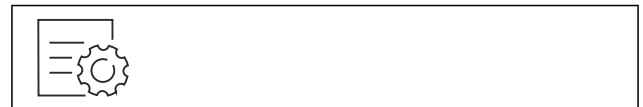

Fig. 59

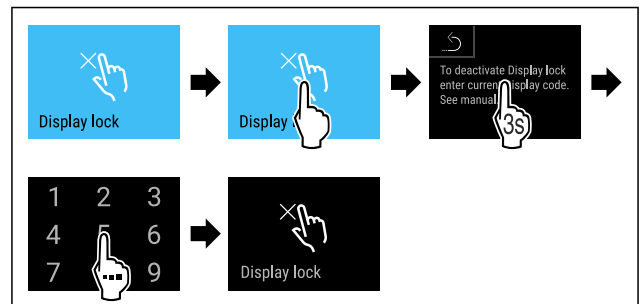

Fig. 60

- ▶ Carry out action steps according to the illustration.
- ▶ The display lock is deactivated.
- ▶ The status display appears.

7.2.15 Access codes

Access codes are required for some functions. You can only use the following functions after entering the appropriate access code:

- Display lock



Code for the display lock

This function allows the display lock code to be changed or reset.

Changing the display lock code

The code can be changed in three steps:

- Enter old code.
- Enter new code.
- Confirm new code.

Note

In the following example, you change the factory-set code **1 1 1 1** to the new code **2 3 4 5**.



Fig. 61

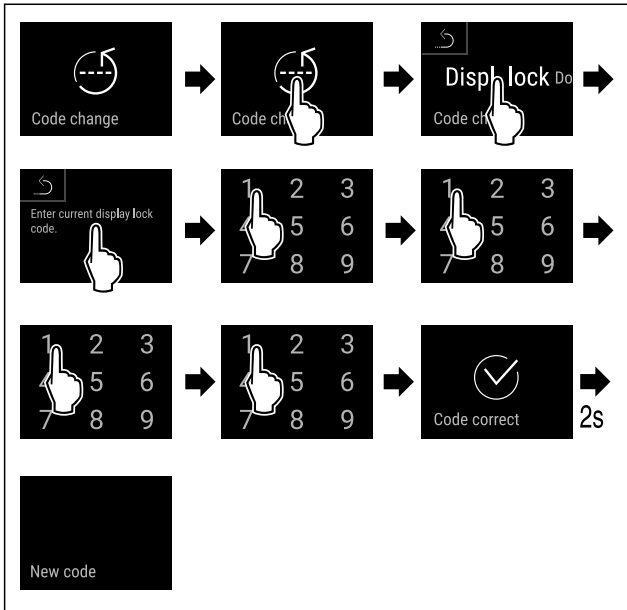

Fig. 62

- ▶ Carry out action steps according to the illustration.
- ▶ Entering the old code is successful.

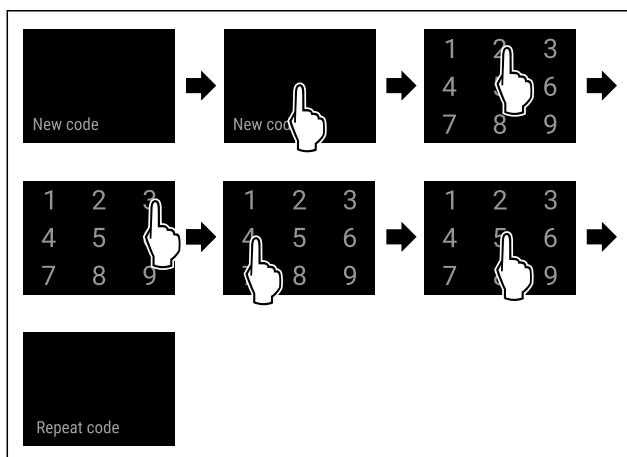

Fig. 63

- ▶ Carry out action steps according to the illustration.
- ▶ The new code has been successfully entered.

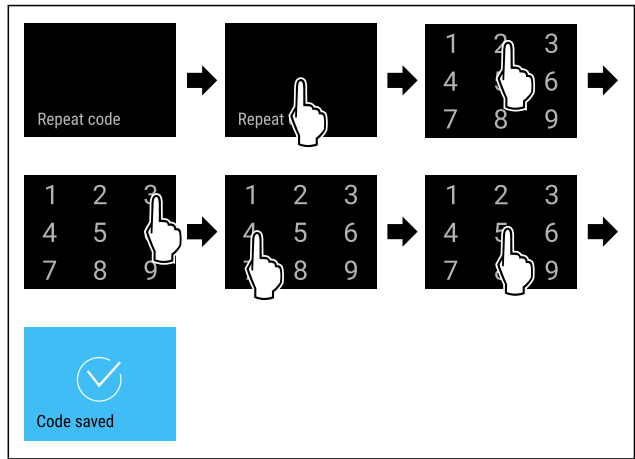

Fig. 64

- ▶ Carry out action steps according to the illustration.
- ▶ Confirmation of the new code is successful.
- ▶ The code has been changed.

Resetting the display lock code

If you no longer know the code, you can reset it.

- ▶ Reset appliance to factory settings. (see 7.2.20 Resetting to factory settings)
- ▶ The appliance has been reset to its original settings.
- ▶ The factory-set code is: **1 1 1 1**

7.2.16 Language



This setting allows the display language to be set.

Setting language

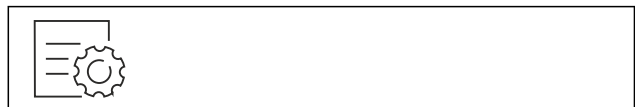

Fig. 65

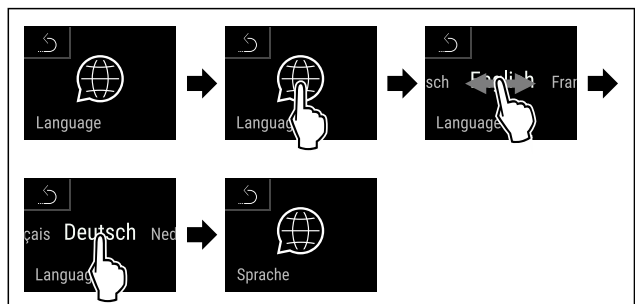

Fig. 66

- ▶ Carry out action steps according to the illustration.
- ▶ The selected language is set.

7.2.17 Appliance and software information



Use this function to indicate the model name, index, serial number and service number of your device. You will need the device information when you contact customer service. (see 10.4 Customer Service)

Indicating the device information

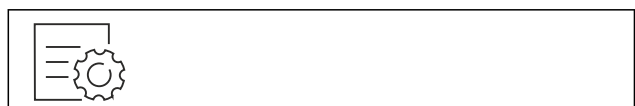

Fig. 67

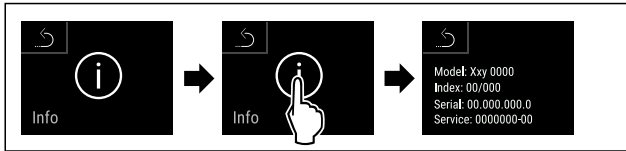

Fig. 68

- ▶ Carry out action steps according to the illustration.
- ▷ Display indicates device information.

Displaying software information



Fig. 69

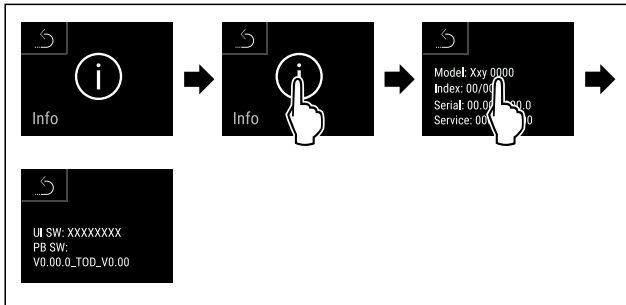

Fig. 70

- ▶ Carry out action steps according to the illustration.
- ▷ Display shows software information.



7.2.18 Reminder

Use this function to activate or deactivate the reminder to change the FreshAir activated carbon filter.

Deactivating the reminder



Fig. 71

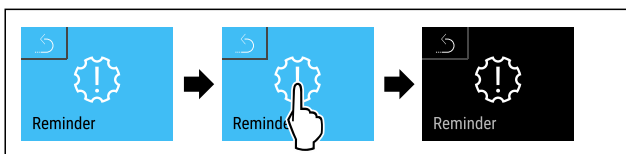

Fig. 72

- ▶ Carry out steps according to the illustration.
- ▷ Reminder is deactivated.

Activating the reminder



Fig. 73

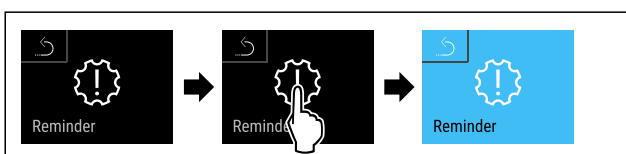
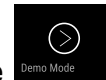

Fig. 74

- ▶ Carry out steps according to the illustration.
- ▷ Reminder is activated.



7.2.19 Demo mode

Demo mode is a special feature for dealers who want to demonstrate appliance features. If you activate demo mode, all refrigeration functions are deactivated.

If you switch on your appliance and a “D” appears on the status display, demo mode is already activated.

If you activate and then deactivate demo mode, the appliance will be reset to factory defaults. (see 7.2.20 Resetting to factory settings)

Activating demo mode

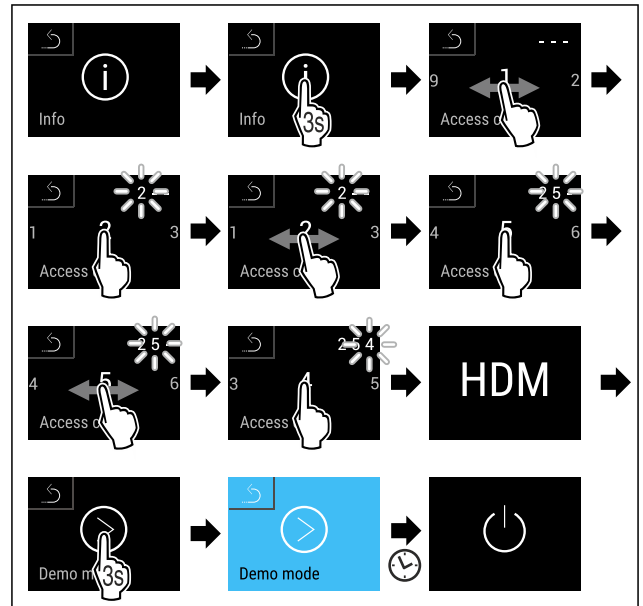

Fig. 75

- ▶ Carry out action steps according to the illustration.
- ▷ Demo mode is activated.
- ▷ Appliance is switched off.
- ▶ Switch on the appliance. (see 4.1 Switching on appliance (first use))
- ▷ “D” appears in the status display.

Deactivating demo mode

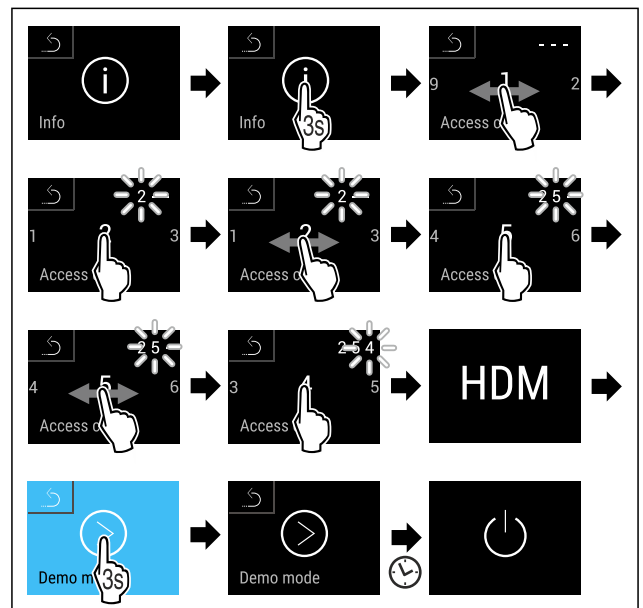

Fig. 76

- ▶ Carry out action steps according to the illustration.
- ▷ Demo mode is deactivated.

- ▷ Appliance is switched off.
- ▷ Switch on the appliance. (see 4.1 Switching on appliance (first use))
- ▷ Appliance is reset to factory settings.



7.2.20 Resetting to factory settings

Use this function to reset all settings to factory defaults. All settings you have made so far are reset to their original settings.

Performing a reset



Fig. 77

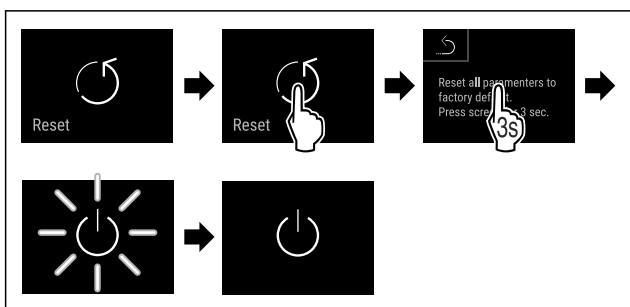

- Fig. 78
- ▶ Carry out action steps according to the illustration.
 - ▶ Device is reset.
 - ▶ Device is switched off.
 - ▶ Restart the device. (see 4.1 Switching on appliance (first use))



7.3 Message

7.3.1 Warnings

Warnings are issued by means of an acoustic signal and visually via a symbol on the display. The signal gets louder until the warning is acknowledged.

Message (red)	Cause	Remedy
 Door open	This message appears if the door is open for too long.	Close the door. Tap briefly. Alarm is stopped. Note The time until the message appears can be set. (see 7.2.10 Door alarm)
 Temperature alarm	This message appears if the temperature does not match the set temperature. Reasons for differences in temperature can be: Warm produce for cooling has been placed inside. Too much warm air has got in while you were sorting out the freezer or removing items. The power was cut off for a prolonged period.	Tap briefly. Information about errors and appliance status are displayed. Tap briefly. Warmest/coldest temperature, date and time are displayed. Tap briefly. The status screen is displayed. The current temperature and the alarm symbol flash red until the set temperature is reached. Check the quality of the refrigerated goods.

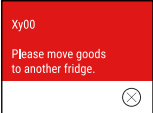
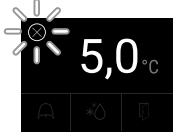
Features

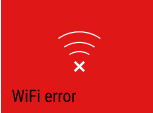
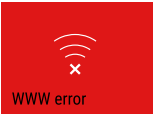
Message (red)	Cause	Remedy
 <p>Device failure</p> <p>Error</p>	<p>The appliance is faulty, there is an appliance error or a component of the appliance has a fault.</p>	<p>Store the cooled produce elsewhere.</p> <p>Tap briefly.</p> <p>The error code (e.g. BT021) is displayed.</p> <p>Tap briefly.</p> <p>A further error code is displayed if there is one</p> <p>or</p> <p>Status screen is displayed with flashing error symbol.</p> <p>Swiping or tapping the display will show the error code(s) again.</p> <p>Make a note of error code(s) and contact Customer Service. (see 10.4 Customer Service)</p>  
 <p>Power failure</p> <p>Power cut</p>	<p>The message appears following an interruption to the electricity supply.</p>	<p>Tap briefly.</p> <p>Battery's state of charge, information about errors and appliance status are displayed</p> <p>Tap briefly.</p> <p>The warmest temperature and the period of power interruptions are displayed.</p> <p>Tap briefly.</p> <p>The status screen is displayed.</p> <p>The current temperature and the alarm symbol flash red until the set temperature is reached.</p> <p>Check the quality of the refrigerated goods.</p>
 <p>WiFi error</p> <p>WiFi error</p>	<p>Wi-Fi connection is interrupted.</p>	<p>Check connection.</p> <p>Press briefly.</p> <p>Alarm is stopped.</p>
 <p>WWW error</p> <p>WWW error, WiFi</p>	<p>This message appears if there is no internet connection via WiFi.</p>	<p>Check connection.</p> <p>Press briefly.</p> <p>Alarm is stopped.</p>

7.3.2 Reminders

Reminders appear when you are being asked to do something. They are issued by means of an acoustic signal and visually via a symbol on the display. Acknowledge the message by pressing the confirmation button.

Message (yellow)	Cause	Remedy
 <p>FreshAir filter</p> <p>ReplaceFreshAir activated charcoal filter</p>	<p>The message appears every 6 months.</p>	<p>ReplaceFreshAir activated charcoal filter, Press briefly.</p> <p>Reminder is closed.</p>

8 Features

8.1 Wooden grid

The appliances are equipped with a wooden grid for wine storage.

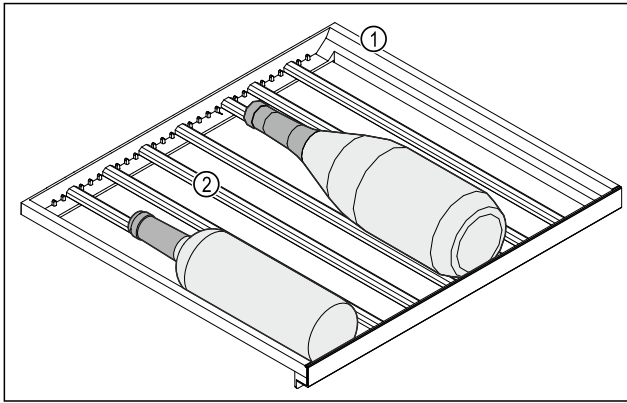

Fig. 79 Example illustration

(1) Wooden grid (2) Bar

The standard positions for the bars are indicated by notches. If you use these, you can store the maximum number of bottles. (see 5.2 Storage sketch)

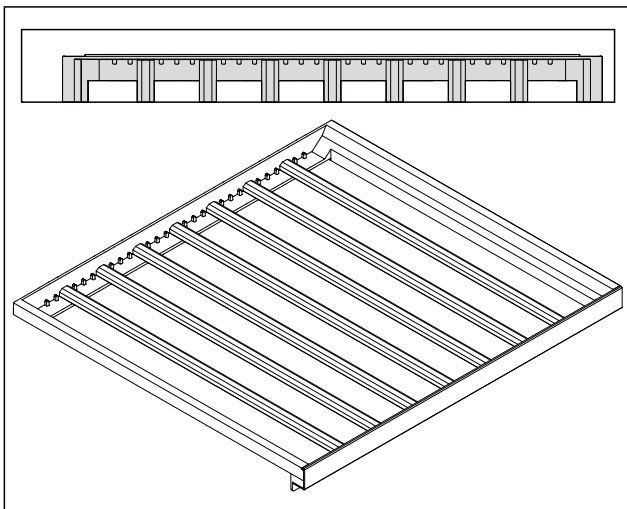

Fig. 80 Arrangement of the bars for maximum number of bottles.

8.1.1 Moving the bar

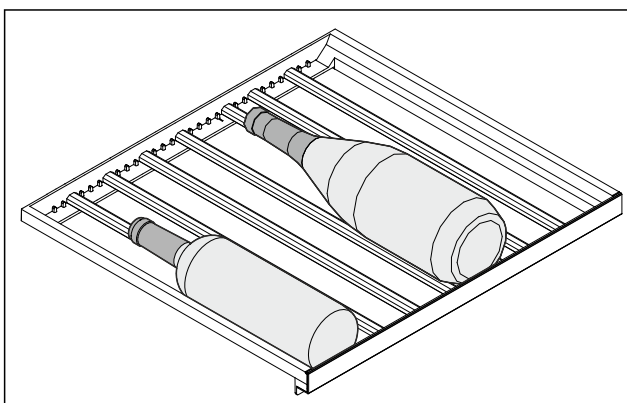

Fig. 81 Example illustration

You can remove the bars in the wooden rack to store larger or smaller bottles.

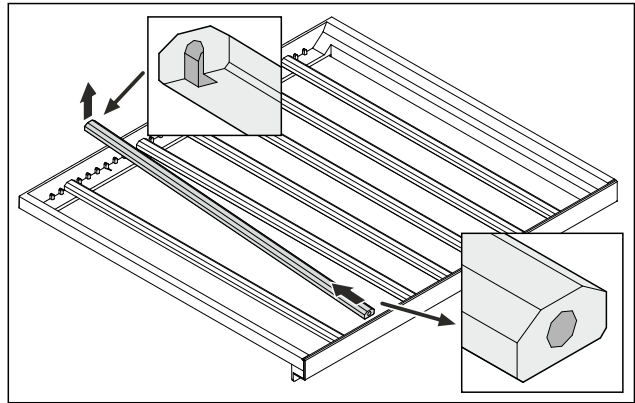

Fig. 82 Example illustration

► Lift and pull out the bar at the rear.

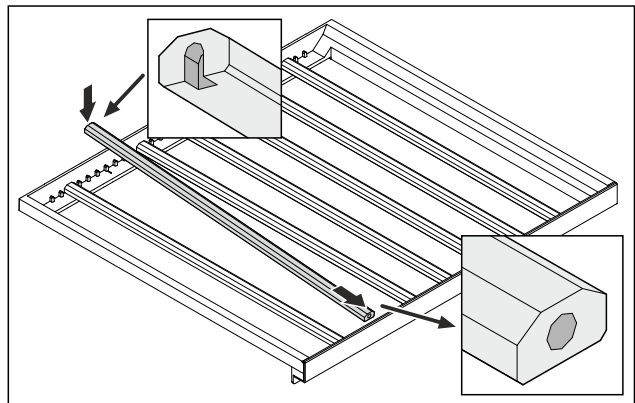

Fig. 83 Example illustration

► Insert the bar in the desired position.

8.1.2 Removing the wooden grid

You can remove the wooden grid for cleaning.

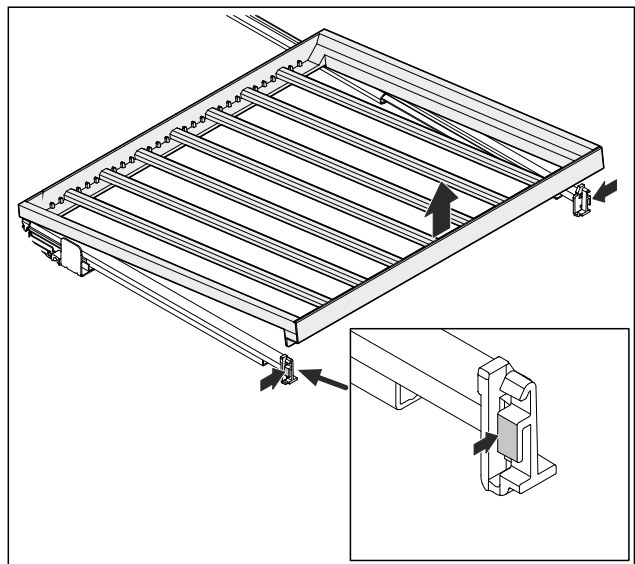

Fig. 84 Example illustration

► Press in slightly on both sides and lift up to remove.

Maintenance

8.1.3 Inserting the wooden grid

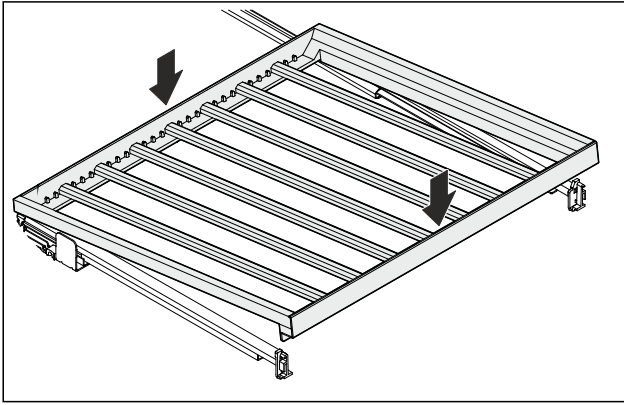

Fig. 85 Example illustration

- ▶ Place the wooden grid at the rear on the rails on the right and left.
- ▶ Lower the wooden grid at the front.
- ▶ The wooden grid locks in.
- ▶ Wooden grid is firmly seated in the rails.

8.2 Labels

Description labels as accessories can be purchased from your specialist dealer. You can use these to note the types of wine that are stored in the respective compartment.

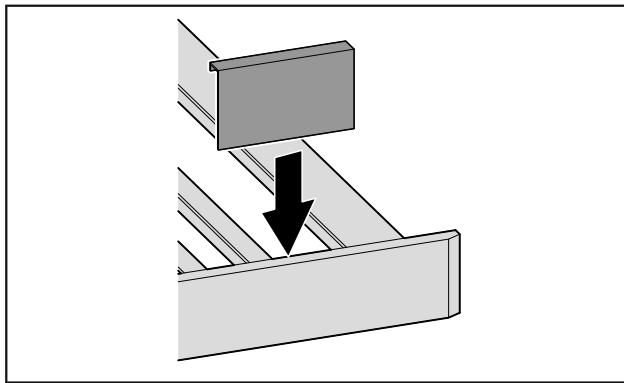

Fig. 86

- ▶ Attach the label from above.

9 Maintenance

9.1 FreshAir activated carbon filter

Wine is constantly developing according to its ambient conditions, so air quality is essential for preservation.

The FreshAir activated charcoal filter guarantees optimal air quality.

- Change the activated charcoal filter every 6 months.
- Dispose of the activated charcoal filter with regular household waste.

Note

FreshAir activated charcoal filters can be purchased from the Liebherr-Hausgeräte store at home.liebherr.com/shop/de/deu/zubehor.html.

9.1.1 Replacing the FreshAir activated charcoal filter

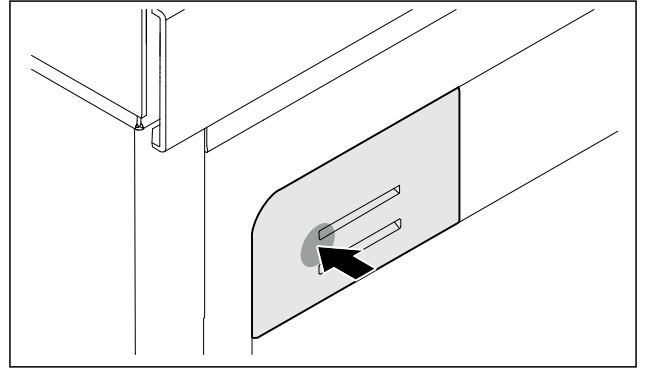

Fig. 87 Example illustration

- ▶ Press the filter holder in, release it again and pull it out.

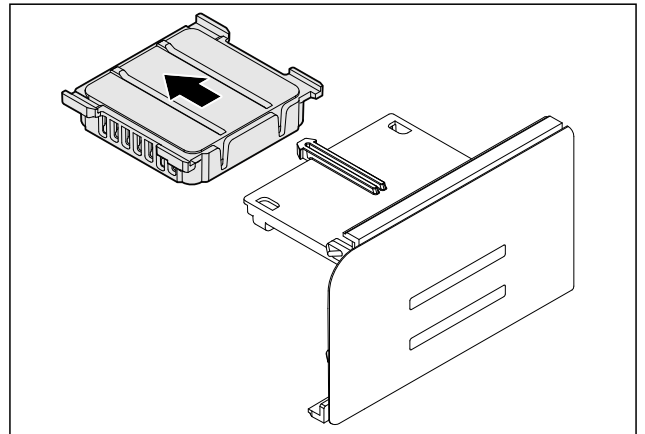

Fig. 88 Example illustration

- ▶ Remove the old filter from the holder.

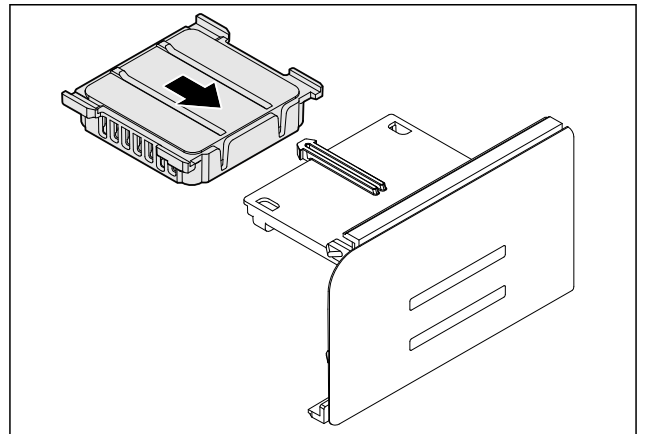

Fig. 89 Example illustration

- ▶ Snap the new filter into the holder.

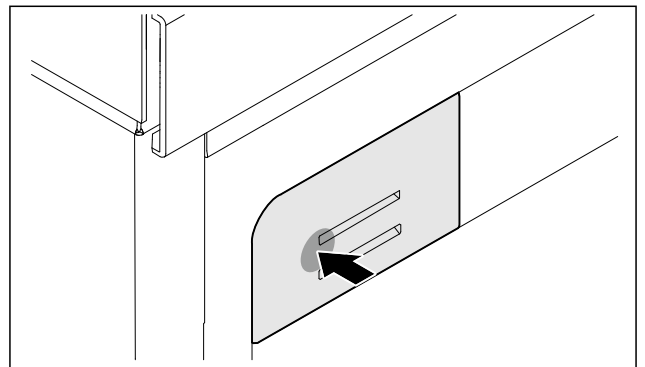

Fig. 90 Example illustration

- ▶ Press the filter holder in as far as it will go and release.
- ▶ FreshAir activated charcoal filter has been changed.

9.2 Cleaning the appliance

9.2.1 Ready



WARNING

Danger of electric shock!

- ▶ Remove the refrigerator connector or interrupt the power supply.



WARNING

Risk of fire

- ▶ Do not damage the refrigeration circuit.

- ▶ Empty the appliance.
- ▶ Remove mains connector.

9.2.2 Cleaning the interior

NOTICE

Improper cleaning!

Damage to the appliance.

- ▶ Only use soft cleaning cloths and ph-neutral all-purpose cleaners.
- ▶ Do not use abrasive sponges or steel wool which may cause scratches.
- ▶ Do not use any sharp or abrasive cleaning agents, nor any that contain sand, chloride or acid.

- ▶ Plastic surfaces: clean by hand with a soft clean cloth, lukewarm water and a little detergent.
- ▶ Metal surfaces: clean by hand with a soft clean cloth, lukewarm water and a little detergent.
- ▶ Drain hole: remove deposits using a thin item (for example a cotton bud).

9.2.3 Clean the components

NOTICE

Improper cleaning!

Damage to the appliance.

- ▶ Only use soft cleaning cloths and ph-neutral all-purpose cleaners.
- ▶ Do not use abrasive sponges or steel wool which may cause scratches.
- ▶ Do not use any sharp or abrasive cleaning agents, nor any that contain sand, chloride or acid.

Clean with a damp cloth:

- Retractable rails
Please note: The grease in the tracks is used for lubrication and must not be removed!

Wash in the dishwasher up to 60 °C:

- Drip tray
- ▶ To disassemble components: see the relevant section.
- ▶ Clean the components.

9.2.4 After cleaning

- ▶ Wipe the appliance and the components dry.
- ▶ Connect and switch on the appliance.
- ▶ Repeat cleaning regularly.

10 Customer help

10.1 Technical specifications

Temperature range	
Cooling	5 °C to 20 °C

For appliances with a WiFi connection:*

Frequency specification*	
Frequency band	2.4 GHz
Maximum radiated power	< 100 mW
Purpose of the wireless equipment	Integration in the local WiFi network for data communication

10.2 Operating noises

The appliance makes different noises when it is on.

- At **higher temperatures** the appliance uses less energy but works for longer. It is **quieter**.
- At **lower temperatures** the food is cooled faster. It is **louder**.

Examples:

- Functions on (see 7.2 Appliance functions)
- Fan running
- Food recently added
- High ambient temperature
- Door open for a while

Noise	Possible cause	Type of noise
Bubbling and splashing	Coolant flowing into the cooling circuit.	Normal operating noise
Hissing	Coolant sprays into the cooling circuit.	Normal operating noise
Humming	The appliance is cooling. The volume depends on the cooling output.	Normal operating noise
Suction noises	Soft-closing door is being opened and closed.	Normal operating noise
Humming and rustling	The fan is running.	Normal operating noise
Clicking	Components are switched on and off.	Normal switching noise
Rattling or humming	Valves or flaps are working.	Normal switching noise

Noise	Possible cause	Type of noise	Lifting
Vibration	Improper installation	Defective noise	Check the installation. Level the appliance.

Noise	Possible cause	Type of noise	Lifting
Rattling	Components, items inside the appliance	Defective noise	Secure components. Leave enough space between the items.

10.3 Technical fault

Your appliance is designed and built to ensure it works reliably and has a long service life. In the unlikely event that a fault occurs during operation, please check whether it is due to an operating error. If so, you will be charged for the callout and repair costs even if it falls within the warranty period.

You can fix the following faults yourself.

10.3.1 Appliance function

Defect	Cause	Remedy
The appliance is not working.	→ The appliance is not switched on.	▶ Switch the appliance on.
	→ The power plug is not properly plugged into the socket.	▶ Check the power plug.
	→ There is something wrong with the power outlet fuse.	▶ Check the fuse.
	→ Power cut	▶ Keep the appliance closed.
	→ The IEC socket is not plugged into the appliance correctly.	▶ Check the IEC socket.
Temperature is not cold enough.	→ The appliance door is not closed properly.	▶ Close the appliance door.
	→ Not enough ventilation.	▶ Keep ventilation grille clear, and clean it.
	→ The ambient temperature is too high.	▶ Problem solution: (see 2.4 Appliance range of use)
	→ The appliance was opened too many times or for too long.	▶ Wait to see if the required temperature corrects itself. If not, contact Customer Service. (see 10.4 Customer Service)
	→ The temperature is set incorrectly.	▶ Turn down the temperature and check after 24 hours.
	→ The appliance is too close to a heat source (oven, radiator, etc).	▶ Move the appliance or the heat source.
	→ The appliance was not correctly installed in the recess.	▶ Check if the appliance was installed correctly and that the door closes properly.
The door seal is defective or needs to be replaced for another reason.	→ You can replace the door seal, depending on your model. It can be replaced without the need for special tools.	▶ Contact Customer Service. (see 10.4 Customer Service)
The door seal is defective or needs to be replaced for another reason.	→ The door seal can be replaced. It can be replaced without the need for special tools.	▶ Contact Customer Service. (see 10.4 Customer Service)
The appliance builds up too much ice or condensation.	→ The door seal may have slipped out of its groove.	▶ Check that the door seal is well fitted in the groove.

10.3.2 Features

Defect	Cause	Remedy
The InfinitySpring is not working.	→ There is air in the water system.	▶ Bleed the water system.
	→ The water connection is not open.	▶ Open the water connection.
The water flow through the Infin-	→ The aerator is dirty.	▶ Replace aerator. Contact Customer Service. (see 10.4 Customer Service)

Defect	Cause	Remedy
itySpring is irregular.		
The internal light does not come on.	→ The appliance is not switched on.	▶ Switch the appliance on.
	→ The door was open for longer than 15 minutes.	▶ Interior lighting switches off automatically after about 15 minutes when the door is open.
	→ The LED interior light is faulty or the lid is damaged.	▶ Contact Customer Service. (see 10.4 Customer Service)

10.4 Customer Service

First check whether you can rectify the fault yourself (see 10 Customer help) . If you cannot rectify the problem, contact Customer Service.

You can find the address at home.liebherr.com/service.



WARNING

Unprofessional repair!
Injuries.

- ▶ Have any repairs and action - not expressly specified - on the appliance and mains cable carried out by service personnel only. (see 9 Maintenance)
- ▶ A damaged mains cable may only be replaced by the manufacturer, the manufacturer's Customer Service or a similarly qualified person.
- ▶ In the case of appliances with an IEC connector, the change may be made by the customer.

10.4.1 Contacting Customer Service

Make sure that the following appliance information is available:

- Appliance name (model and index)
- Service no. (Service)
- Serial no. (S no.)
- ▶ Call up the appliance information via the display.
- or-
- ▶ Refer to the type plate for appliance information. (see 10.5 Model plate)
- ▶ Note down the appliance information.
- ▶ Notify customer service: Report errors and the appliance information.
- ▶ This will help us to provide you with a faster, more accurate service.
- ▶ Follow further instructions from Customer Service.

10.5 Model plate

The type plate is located on the bottom inside of the machine.

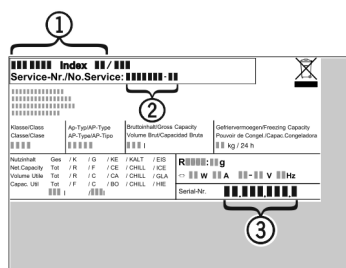

Fig. 91

- (1) Appliance description (3) Serial no.
(2) Service no.

- ▶ Note the data on the model plate.

11 Shutting down

- ▶ Empty the appliance.
- ▶ Switch off appliance. (see 7.2.2 Switching appliance on and off)
- ▶ Pull the mains plug out of the socket.
- ▶ Remove the IEC socket if required: Pull the IEC socket out of the appliance plug and move it to the left and right at the same time.
- ▶ Clean appliance. (see 9.2 Cleaning the appliance)
- ▶ Leave the door open, so that no unpleasant odours arise.



home.liebherr.com/fridge-manuals

EN wine cooling cabinet

Issue date: 20260317

Part number index: 7083723-00

Liebherr-Hausgeräte GmbH
Memminger Straße 77-79
88416 Ochsenhausen
Deutschland