

Operating instructions

NoFrost combined refrigerator-freezer

Page 28

EN

Installation instructions

for NoFrost combined refrigerator-freezers

Page 42

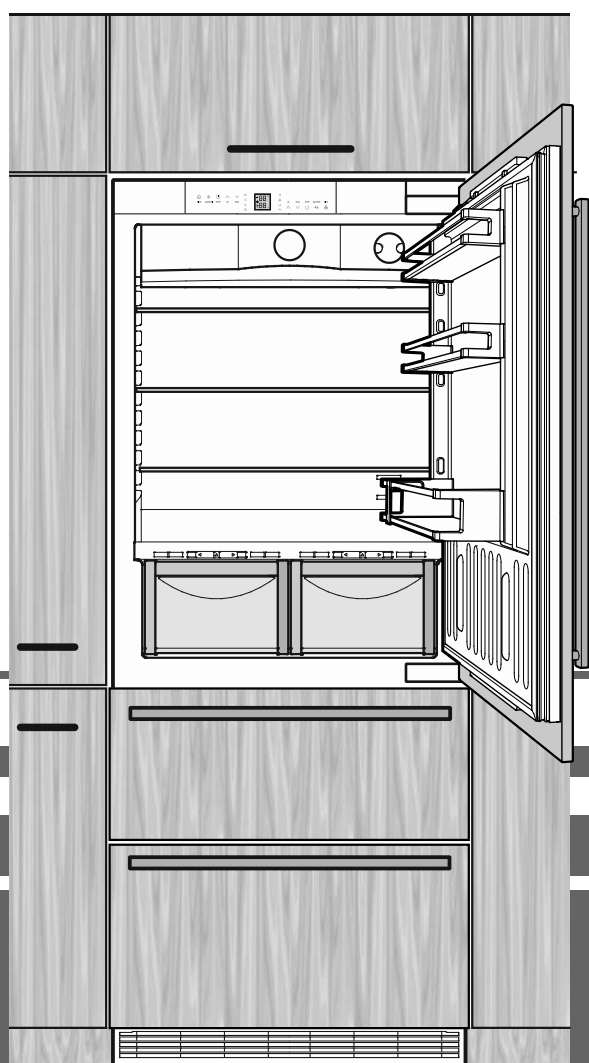

7083 684-00

ECBN 787

V: 01_2025

LIEBHERR

Safety instructions and warnings

- To prevent injury or damage to the unit, the appliance should be unpacked and set up by two people.
- In the event that the appliance is damaged on delivery, contact the supplier immediately before connecting to the mains.
- To guarantee safe operation, ensure that the appliance is set up and connected as described in these operating instructions.
- Disconnect the appliance from the mains if any fault occurs. Pull out the plug, switch off or remove the fuse.
- When disconnecting the appliance, pull on the plug, not on the cable.
- Any repairs and work on the appliance should only be carried out by the customer service department, as unauthorised work could prove highly dangerous for the user. The same applies to changing the mains power cable.
- Do not allow naked flames or ignition sources to enter the appliance. When transporting and cleaning the appliance ensure that the refrigerant circuit is not damaged. In the event of damage, make sure that there are no ignition sources nearby and keep the room well ventilated.
- Do not stand on the plinth, drawers or doors or use them to support anything else.
- This appliance can be used by children of 8 years old and over, and also by persons with restricted physical, sensory or mental capacity or lack of experience and knowledge, if they are supervised or have been instructed on safe use of the appliance and understand the resulting risks. Children must not be allowed to play with the appliance. Cleaning and user maintenance must not be carried out by children without supervision.
- Avoid prolonged skin contact with cold surfaces or chilled/frozen food. This could cause pain, numbness and frostbite. In the case of prolonged skin contact, protective measures should be taken, e.g. gloves should be worn.
- Do not eat ice cream, particularly ice lollies or ice cubes, immediately after taking them from the freezer compartment as there is a risk of "burning" because of the very cold temperatures.
- Do not consume food which has been stored for too long, as it could cause food poisoning.

- Do not store explosives or sprays using combustible propellants such as butane, propane, pentane etc. in the appliance. Electrical components might cause leaking gas to ignite. You may identify such sprays by the printed contents or a flame symbol.
- Do not use electrical appliances inside the appliance.
- The appliance is designed for use in enclosed areas. Do not operate the appliance outdoors or in areas where it is exposed to splash water or damp conditions.
- The LED light strips illuminate the interior of the appliance. They are not suitable for lighting a room.

Disposal notes

The appliance contains reusable materials and should be disposed of properly - not simply with unsorted household refuse. Appliances which are no longer needed must be disposed of in a professional and appropriate way, in accordance with the current local regulations and laws.

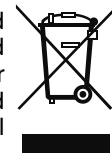

When disposing of the appliance, ensure that the refrigerant circuit is not damaged to prevent uncontrolled escape of the refrigerant it contains (data on type plate) and oil.

- Disable the appliance.
- Pull out the mains plug.
- Cut through the connection cable.



WARNING

Danger of suffocation due to packing material and plastic film! Do not allow children to play with packaging material. Take the packaging material to an official collection point.



A sticker to this effect may be applied to the rear of the appliance. It refers to the foampadded panels in the door and/or the housing. This is only relevant for recycling. Do not remove the sticker.

EPREL database

As from 1 March 2021, information about energy labelling and ecodesign requirements will be available in the European product database (EPREL). You can access the product database using the following link: <https://eprel.ec.europa.eu/>. You will be asked to enter the model identifier. You will find the model identifier on the type plate.

Description of the appliance

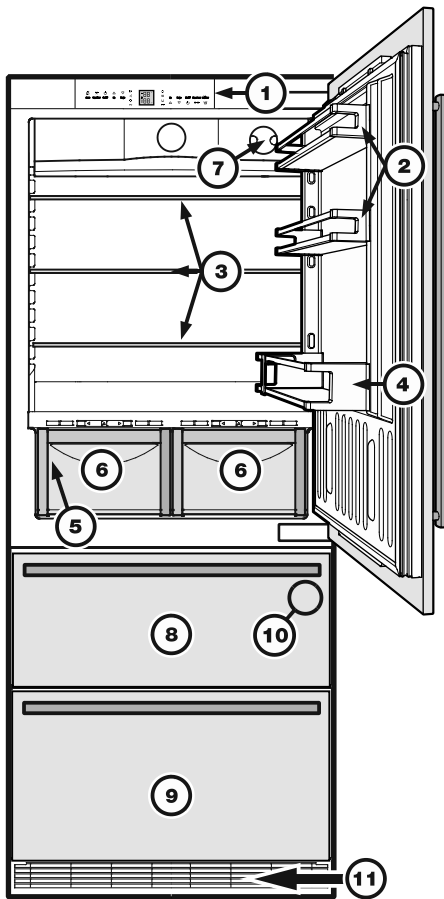

- (1) Operating and control elements
- (2) Adjustable door racks
- (3) Adjustable storage shelves
- (4) Bottle racks
- (5) Type plate (behind the vegetable drawer on the left-hand side)
- (6) Vegetable drawers
- (7) Water filter
- (8) Upper freezer drawer
- (9) Lower freezer drawer
- (10) IceMaker (in the interior of the upper freezer drawer)
- (11) Ventilation grille. In this area, the exchange of air for the refrigeration unit takes place.

Never cover this grille or otherwise obstruct the air flow!

Temperature and control display

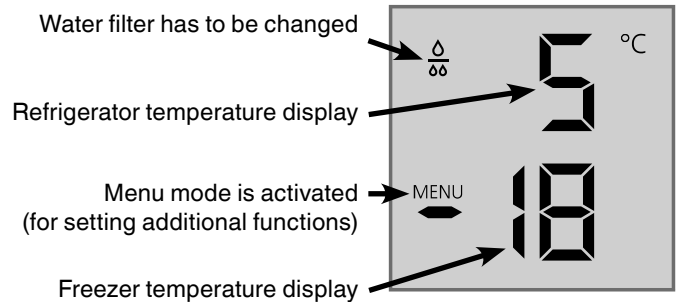

Operating and control elements

The electronic control panel has the "touch capacitance technology". Any function can be activated by touching the corresponding icon.

The exact contact point is between the symbol and its label  On/Off

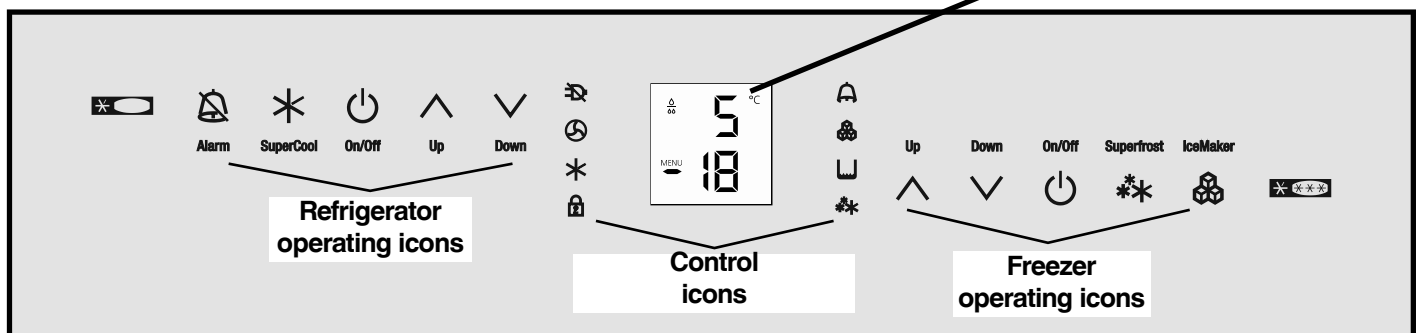

Refrigerator operating icons

- Mute alarm (refrigerator and freezer)
- SuperCool
- Refrigerator ON/OFF
- Temperature setting buttons

Control icons

- Power failure LED
- Dust filter LED
The dust filter in the appliance plinth must be cleaned.
- SuperCool LED
- Child lock LED
- Alarm LED
- IceMaker ON LED
- SuperFrost LED

Freezer operating icons

- Temperature setting icons
- Freezer ON/OFF
- SuperFrost
- IceMaker ON/OFF

Range of appliance use

The appliance is suitable solely for cooling food in a domestic environment or similar. This includes, for example, use

- in staff kitchenettes, bed and breakfast establishments,
- by guests in cottages, hotels, motels and other forms of accommodation,
- in catering and similar services in the wholesale trade.

Use the appliance solely as is customary within a domestic environment. All other types of use are inadmissible. The appliance is not suitable for storing and cooling medicines, blood plasma, laboratory preparations or similar substances and products covered by the 2007/47/EC Medical Devices Directive. Any misuse of the appliance may result in damage to or spoilage of stored goods. Furthermore, the appliance is not suitable for operation in potentially explosive atmospheres.

Climate rating

The climate rating indicates the room temperature at which the appliance may be operated in order to achieve full refrigeration performance.

The climate rating is indicated on the type plate.

The position of the type plate is shown in the section entitled **Description of the appliance**.

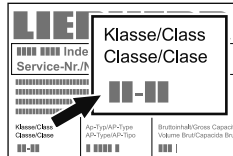

Climate rating	Room temperature
SN	+10°C to +32°C
N	+16°C to +32°C
ST	+16°C to +38°C
T	+16°C to +43°C
SN-ST	+10°C to +38°C
SN-T	+10°C to +43°C

Do not operate the appliance outside the specified room temperature range.

Saving energy

- Always ensure good ventilation. Do not cover ventilation openings or grille.
- Always keep fan slits clear.
- Do not place appliance in areas of direct sunlight or next to a cooker, radiator or similar object.
- The energy consumption depends on the installation conditions, e.g. the ambient temperature.
- Keep the time the appliance is open to a minimum.
- Store food logically.
- Ensure that all food is well packed and covered for storage. This will prevent frost from forming.
- First cool warm food to room temperature before storing it.
- Defrost frozen food in the refrigerator.
- Empty and switch off refrigerating unit for longer vacation periods.

Water filter

Before switching on the appliance, install the water filter provided in the interior rear wall of the refrigerator compartment.

This ensures good ice cube quality and keeps the water circuit free of solids such as sand.

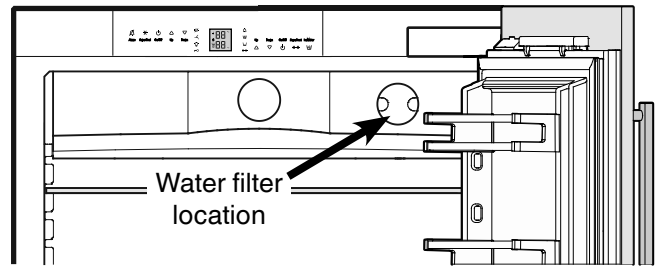

Replace the filter when the waterdrop symbol appears in the temperature display.

Filters can be obtained from your dealer.

The drop symbol must be cancelled after the filter has been changed. For detailed instructions see section entitled "Setup mode".

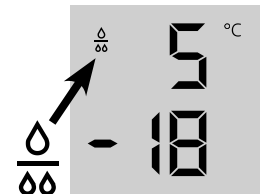

Caution!

To avoid the risk of bacteria growth, the water filter must be changed when the waterdrop symbol appears on the display!

It is not necessary to switch off the water supply when removing or installing the water filter.

Installing the water filter

1. Remove the cover of the filter socket.

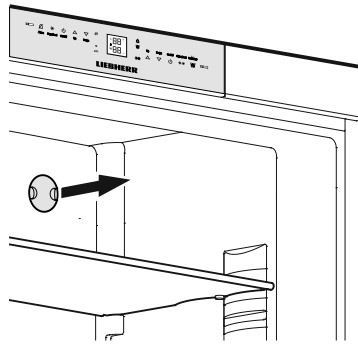

2. Insert the filter and turn it 90° clockwise.

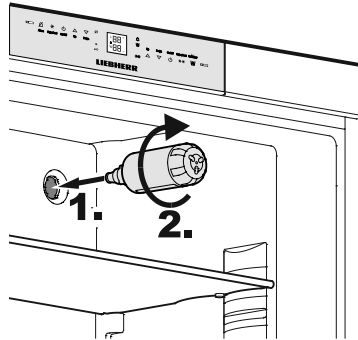

Removing the water filter

3. Turn the filter 90° anticlockwise and remove.

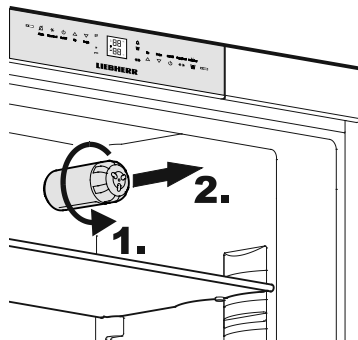

Partition for bottom freezer drawer

If required, the partition supplied in the accessories set can be inserted in the bottom drawer on the left or right.

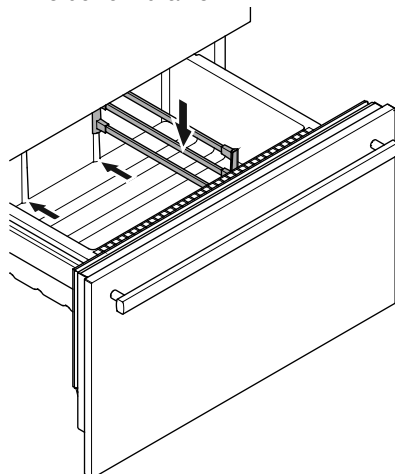

Switching the appliance on and off

You are advised to clean the appliance before switching it on for the first time (see "Cleaning").

Do not load with frozen food until the temperature shows at least -18°C. The refrigerator and freezer compartments can be operated separately.



Switching on: touch the On/Off icons (on left for refrigerator, on right for freezer) so that the temperature displays light up or flash.



Switching off: keep the On/Off icons pressed for approx. 3 seconds.

Setting the temperature

The appliance is pre-set for normal operation. We recommend temperatures of +5°C in the refrigerator and -18°C in the freezer.



To reduce the temperature: touch the **Down** icon; on left for refrigerator and on right for freezer.

Down Up

To increase the temperature: touch the **Up** icon.



- While you are entering the temperature, the set temperature will flash on the display.
- When you touch the temperature setting icons for the first time, the most recent setting ("reference setting") is displayed.
- You can change the settings in increments of 1°C by briefly touching the icons again. If the icons are held, the temperature setting will change faster.
- Approximately 5 seconds after the last touch, the display will automatically show the actual freezing or cooling temperature ("actual setting").
- You can change the temperatures in the refrigerator: between 9°C and 3°C and in the freezer: between -14°C and -28°C.

Temperature display

In normal operation, the following settings will be displayed:

- the average refrigerator temperature and
- the warmest frozen food temperature.

When starting up for the first time or when the appliance is warm, dashes will appear until the temperature reaches a level that can be displayed (below 0°C in the freezer).

The display will flash:

- if you change the temperature or
- if the temperature rises by several degrees, indicating cold loss, e.g. if you place fresh, "warm" food in the freezer or if you remove or re-pack frozen food, the temperature may rise for a short time due to warm air flowing into the freezer.

If **F1** to **F5** appears in the display, the appliance has a fault. Consult the customer service department indicating the fault number displayed.

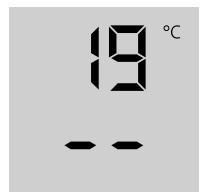

Audible warning signal

The appliance is equipped with an alarm function.

Audible door alarm

If an appliance door is left open for more than 60 seconds, the audible warning signal will sound. Touch the **ALARM** icon to cancel the alarm. The alarm switches back to standby when the door is shut.



Audible/visual temperature alarm

It sounds when it is not cold enough in the freezer compartment. The temperature display and the  LED will also flash.

The audible warning device is switched off by touching the **ALARM** icon. The temperature display will continue to flash until the cause of the alarm has been rectified.

This can be caused by:

- the freezer door being left open for a long time, allowing warm ambient air to enter;
- a long power failure;
- a fault in the appliance.

In each case, make sure food has not thawed or perished.

Power failure/FrostControl display

If the  LED comes on on the control panel, this means that the freezer temperature has risen too high during the last few hours or days due to a power failure.

If you touch the **ALARM** icon now, the highest temperature registered during the power failure will be displayed.



Check the quality of the food and its suitability for consumption in case it has become too warm or even defrosted.

The highest temperature will appear for approx. 1 minute. After that, the actual temperature in the freezer will re-appear.

The display can be switched off by touching the **ALARM** icon.

SuperCool

Touching the SuperCool icon switches the refrigerator compartment to maximum cooling. It is recommended particularly if you wish to cool large quantities of food, drinks, freshly baked goods or meals rapidly.

Switching on: Touch the SuperCool icon briefly so that the LED  comes on. The refrigerator temperature will drop to its lowest value.

SuperCool

Note: The SuperCool function uses slightly more energy. After approximately six hours, however, the refrigerator switches back automatically to normal energy-saving operation. If required, the SuperCool function can be switched off sooner.

Switching off: Touch the SuperCool icon again until the LED  goes out.

Setup mode

The following functions can be activated in setup mode:

 = Sabbath mode

 = Child lock

 = Confirm water filter change

 = Ice maker vacation state

 = Water quantity for ice cube tray





 = Set BioFresh temperature

 = Display brightness

 = Door gasket heating control

 = Confirm dust filter cleaning

Activating setup mode

- Touch the **SuperFrost** icon for five seconds.  
- The **SuperFrost LED**  comes on for 5 seconds,
- after 5 seconds  will flash in the display.

The appliance is in setup mode now.



You can select the setup mode functions by touching the freezer compartment temperature setting icons.



Note

In setup mode the display will flash continuously.

Exiting setup mode

- Touch the freezer compartment **On/Off** icon  

The appliance will change back to normal operation.

⌘ = Sabbath mode

This function complies with the religious requirements to be observed on the Sabbath or religious holidays.

When Sabbath mode is activated, some of the functions of the control electronics are switched off.

- The interior light remains switched off if one of the appliance doors is opened.
- The interior fan remains in the status which is currently set (On or Off) if an appliance door is opened.
- No door open alarm.
- No temperature alarm.

Activating the sabbath mode

- Activate setup mode by touching the **SuperFrost** icon for 5 seconds.

- The display reads ⌘

- Touch the **SuperFrost** icon.

- The display reads 

- Touch the **SuperFrost** icon again.

- The display reads 

The sabbath mode is activated.

- Exit setup mode by touching the freezer compartment **On/Off** icon.

Note

The Sabbath mode is deactivated automatically after 120 hours.

Deactivating the sabbath mode

- Activate setup mode by touching the **SuperFrost** icon for 5 seconds.

- The display reads ⌘

- Touch the **SuperFrost** icon.

- The display reads 

- Touch the **SuperFrost** icon again.

The ⌘ in the display will go out.



The sabbath mode is deactivated.

- Exit setup mode by touching the freezer compartment **On/Off** icon.



⌘ = Child lock

The child lock is designed to protect the appliance from being switched off accidentally.

Activating the child lock

- Activate setup mode by touching the **SuperFrost** icon for 5 seconds.
- Touch the freezer compartment **Down** icon until ⌘ appears in the display.
- Touch the **SuperFrost** icon.
 - The display reads 
- Touch the **SuperFrost** icon again.
 - The  LED is lit and the child lock is activated.
- Exit setup mode by touching the freezer compartment **On/Off** icon.



Deactivating the child lock

- Activate setup mode by touching the **SuperFrost** icon for 5 seconds.
- The display reads 
- Touch the **SuperFrost** icon.
 - The display reads 
- Touch the **SuperFrost** icon again.
 - The  LED goes out. The child lock is deactivated.
- Exit setup mode by touching the freezer compartment **On/Off** icon.

F = Confirm water filter change

After the water filter has been changed, the drop symbol on the display must be reset.

Resetting the drop symbol

- Activate setup mode by touching the **SuperFrost** icon for 5 seconds.
- Touch the freezer compartment **Down** icon until F appears in the display.
- Touch the **SuperFrost** icon.
 - The display reads 
- Touch the **SuperFrost** icon again.
 - The display reads 
- The drop symbol disappears.
- Exit setup mode by touching the freezer compartment **On/Off** icon.

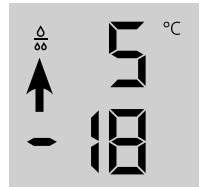

I = Ice maker vacation state

See section entitled "Ice maker".

E = Water quantity for ice cube tray

If the produced ice cubes of the ice maker are too small, the inflowing water quantity can be adjusted.

Adjusting the water quantity

- Activate setup mode by touching the **SuperFrost** icon for 5 seconds.
- Touch the freezer compartment **Down** icon until **E** appears in the display.

- Touch the **SuperFrost** icon.
- The display reads 

- Touch the freezer compartment **Up** icon once only so that **E4** appears in the display.

Caution!

Do not increase for more than one step. If the adjusted value is too high, the ice cube tray of the ice maker could overflow.

- Touch the **SuperFrost** icon again.
- Exit setup mode by touching the freezer compartment **On/Off** icon.

Check the ice cube size within the next days. If the ice cubes are still too small, follow the steps above again.

b = Set BioFresh temperature

The temperature in the BioFresh drawers may be changed.

Setting the BioFresh temperature

- Activate setup mode by touching the **SuperFrost** icon for 5 seconds.
- Touch the freezer compartment **Down** icon until **b** appears in the display.

- Touch the **SuperFrost** icon.
- The display reads 

- Touch the freezer compartment **Up/Down** icons and set
b6 - b9 to increase the temperature (warmer),
b4 - b1 to reduce the temperature.



CAUTION!

For values b4 - b1, the temperature in the drawers can drop to below 0°C. Food may freeze.

- Touch the **SuperFrost** icon at the desired value.
- Exit setup mode by touching the freezer compartment **On/Off** icon.

h = Display brightness

Adjusting the display brightness

- Activate setup mode by touching the **SuperFrost** icon for 5 seconds.
- Touch the freezer compartment **Down** icon until **h** appears in the display.

- Touch the **SuperFrost** icon.
- The display reads 

- Touch the freezer compartment **Up/Down** icons to select

h0 = minimum to

h5 = maximum brightness.

- Touch the **SuperFrost** icon at the desired value.

- Exit setup mode by touching the freezer compartment **On/Off** icon.

H = Lower hinge heating control

If condensed water appears in the lower hinge area or on the base plate between refrigerator and freezer compartment, increase the output of the heating located behind the base plate.

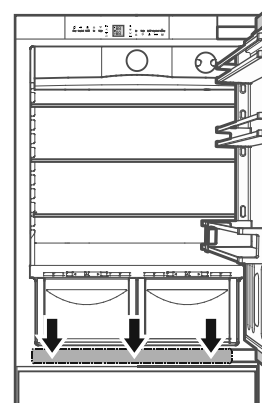

The factory setting is set to **HA** = medium output.

Changing the heating output

- Activate setup mode by touching the **SuperFrost** icon for 5 seconds.
- Touch the freezer compartment **Down** icon until **H** appears in the display.

- Touch the **SuperFrost** icon.
- The display reads 

- Touch the freezer compartment **Up/Down** icons to select

HA = at slight condensation

H1 = at heavy condensation

H0 = heating off

- Touch the **SuperFrost** icon at the desired value.

- Exit setup mode by touching the freezer compartment **On/Off** icon.





Note

With normal ambient conditions no condensation will appear. With high humidity and low ambient temperature this feature helps to prevent condensation.

☐ = Confirm dust filter cleaning

Once the dust filter in the appliance plinth has been cleaned, the dust filter LED  in the display must be cancelled.

Cancelling the dust filter symbol

- Activate setup mode by touching the **SuperFrost** icon for 5 seconds.
- Touch the freezer compartment **Down** icon until ☐ appears in the display.
- Touch the **SuperFrost** icon.
- The display reads 
- Touch the **SuperFrost** icon.
- The display reads 
- The dust filter symbol has been cancelled.
- Exit setup mode by touching  the freezer compartment **On/Off** icon. 

Equipment

Repositioning the door racks

Lift door rack vertically, lift out to the front and re-insert at a different height, following these steps in the reverse order.

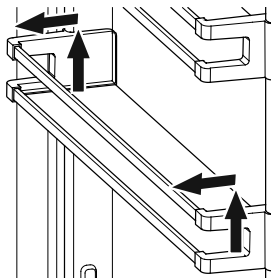

By shifting the **bottle holder** you can protect the bottles from falling over when opening or closing the door.

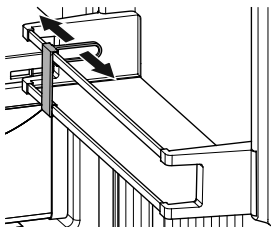

Repositioning the shelves

Note: Danger of damage through sharp edges. Damage to the surfaces/glass shelves. Carefully insert the glass shelves.

1. Hold the shelf underneath with your hand to prevent from tipping down backwards when removing.
2. Lift the shelf at the front.
3. Pull the shelf towards you until the round cutout of the shelf is in line with the interior light cover.
4. Lift the shelf up and replace in the desired position.

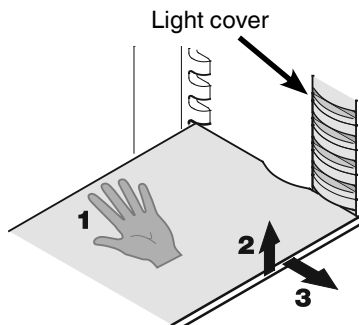

Removing the shelves

1. Follow the first three steps in the chapter above.
2. Move the shelf down and stop just over the vegetable drawer.
3. Move the front of the shelf upwards until the shelf is in a vertical position.
4. Turn the shelf by 90° and remove.

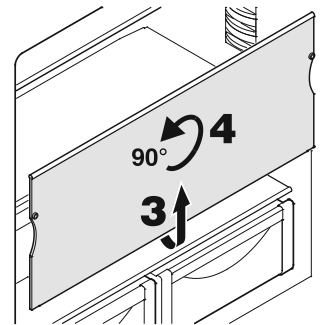

Bottle shelf

The shelf above the BioFresh drawers can be used for storing bottles horizontally.

Remove the glass plate and insert it under the shelf plate.

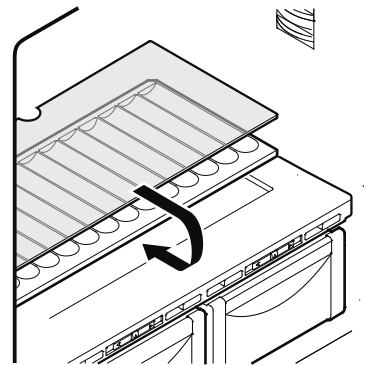

The recesses in the shelf plate ensure that the bottles are stored securely.

When storing tall bottles, the bottom door rack must be moved further up.

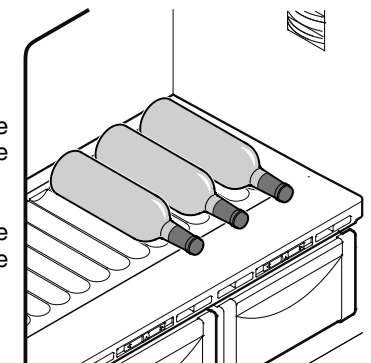

Removing the BioFresh drawer

Pull the drawer straight out, grip at the back and lift out.

Inserting the BioFresh drawer

Place the drawer on the pull-out rails. The rails must be fully extended and aligned with the front of the drawer. Slide the drawer in.

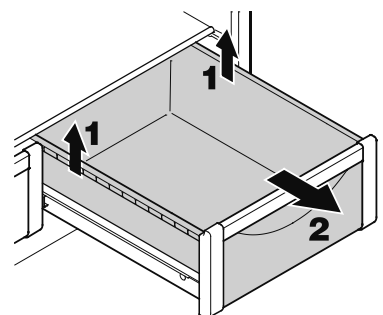

Interior light

The interior light is located at the left, right and top in the refrigerator compartment and above each drawer in the freezer compartment. It comes on if one of the doors or a freezer drawer is opened.

The light switches off automatically if one of the doors or a freezer drawer has been left open for more than 15 minutes. The audible warning signal sounds at the same time.

If one of the strip lights is not lit, it is defective.

The light intensity of the LED light corresponds to laser class 1/1M.

Important

The light cover may only be removed by customer service staff. If the cover is removed, do not look directly at the light through optical lenses from close distance. This can damage your eyes.

Lighting	
Class ¹	Light source
This product contains a light source that meets energy efficiency rating G	LED
¹ The appliance may contain light sources with different energy efficiency classes. The lowest energy efficiency class is indicated.	

Arranging food

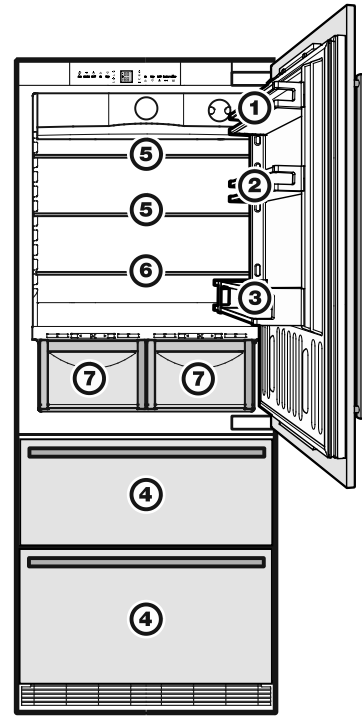

- (1) butter, cheese
- (2) eggs
- (3) bottles
- (4) frozen food, ice cubes
- (5) meat, sausage products, dairy products
- (6) baked goods, pre-cooked meals
- (7) fruit, vegetables, salads (for high humidity setting)
meat, cold meats, dairy products (for low humidity setting)

The adjustable humidity is explained in the **BioFresh compartment** section.

Note

- Food which gives off or absorbs odours and flavours as well as liquids should always be stored covered or in closed containers.
- High-percentage alcohols should be tightly sealed and stored upright.

BioFresh compartment

The BioFresh compartment enables you to keep food for up to 3 times longer than in normal refrigerators.

The constant temperature of just above 0°C and the adjustable humidity provide the ideal storage conditions for different types of food.

The BioFresh compartment satisfies the requirements of a chill compartment to EN 62552:2021.

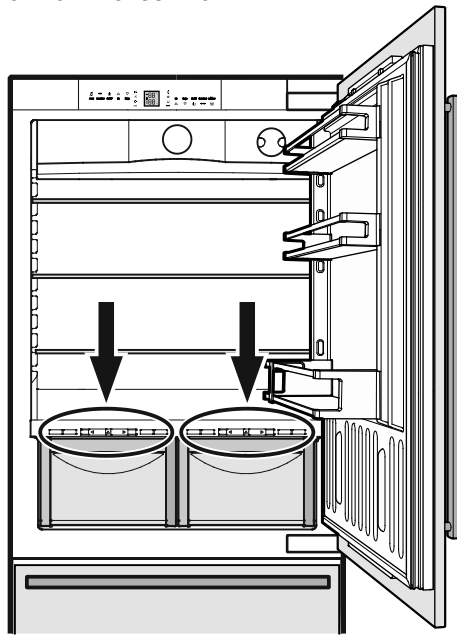

Humidity selection

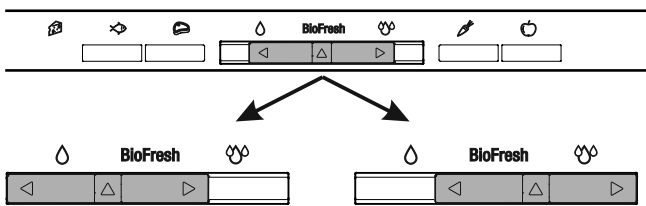

Dry

Small humidity symbol - slide control to left.

This setting is suitable for dry or wrapped food like dairy products, meat, fish, cold meats.

Humid

High relative humidity of max. 90%, large humidity symbol - slide control to right.

This setting is suitable for storing unwrapped food with a high moisture content such as salad, vegetables and fruit.

Notes

- The humidity in the compartment depends on the moisture content of the food in it, and the frequency with which the compartment is opened.
- The fresher the product and the higher its quality, the longer it will keep.
- Unwrapped animal and vegetable foods should be stored separately in the drawers. If there is not enough space for them to be stored separately, make sure that they are wrapped. Do not allow different types of meat to come into contact with one another but keep them packaged separately so as to avoid premature bacterial spoilage.
- The following products should not be stored in the BioFresh compartment: hard cheese, potatoes, cold-sensitive vegetables such as cucumbers, aubergines, avocados, semiripe tomatoes, zucchini, all cold-sensitive tropical fruits such as pineapples, bananas, grapefruit, melons, mangos, papayas, etc.

Freezer compartment description

Both drawers can be used for freezing of food or storage of frozen food.

Important

In order to achieve the most efficient energy consumption possible, the container of the bottom freezer drawer must be inserted in the appliance.

The ice cube bin in the upper drawer is intended for ice cubes only.

If you need the whole upper drawer for freezing or storage, the ice cube bin can be removed.

Important

The ice maker will not eject the ice cubes of its tray if the bin has been removed.

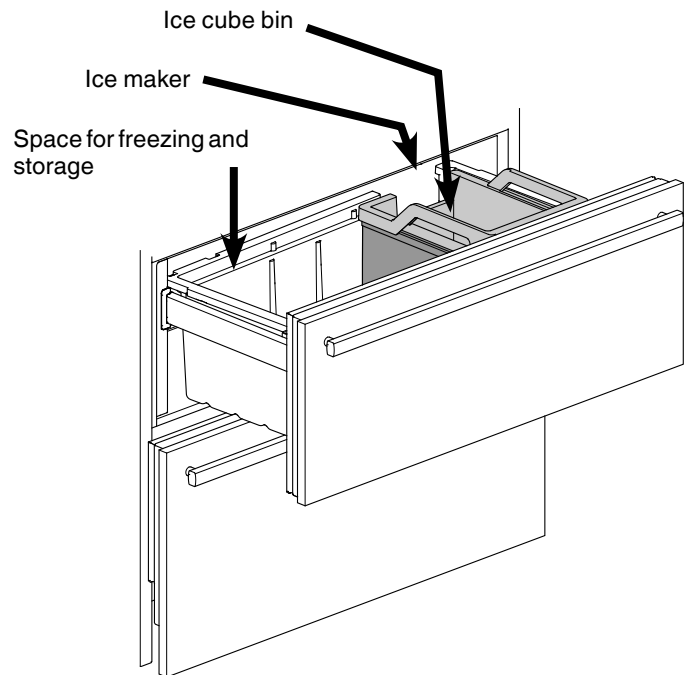

Freezing

Fresh food should be frozen to the core as rapidly as possible. Frozen food can also be given a cold boost. This is provided by the SuperFrost facility.

The maximum amount of food (in kg) which can be frozen in 24 hours is shown on the type plate ("Freezing capacity").

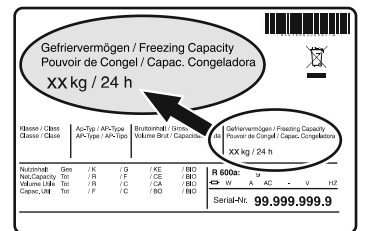

Freezing with SuperFrost

Touch the SuperFrost icon  briefly so that the  LED comes on.

- For small amounts of frozen food switch on SuperFrost 6 hours beforehand. For the maximum amount (see freezing capacity on the type plate) you will need to switch it on 24 hours beforehand.
- Then place the fresh food inside the freezer.
- The SuperFrost function switches **off automatically**. Depending on the quantity of food placed in the freezer, this will normally be between 30 and max. 65 hours. The freezing process is now complete, the **SuperFrost LED will go out**.

You should not switch on the SuperFrost function:

- when placing frozen food in the freezer;
- when freezing up to approx. 2 kg fresh food daily.

Notes on freezing

- Always store identical food items together.
- Pack food which you are freezing yourself in quantities appropriate to your household. To ensure that the food freezes right through, the following quantities should not be exceeded per package: fruit, vegetables: up to 1 kg, meat: up to 2.5 kg.
- Pack frozen food in standard freezer bags or reusable plastic, metal or aluminium containers.
- Do not allow fresh food which is to be frozen to come into contact with food already frozen. Always keep packs dry in order to avoid them sticking together.
- Always write the date and contents on the pack and do not exceed the stated storage time for the food.
- Do not freeze bottles and cans which contain carbonated drinks as they might burst.
- Only take out as much food as is immediately required for thawing. Use food which has been thawed in prepared meals as quickly as possible.

Frozen food can be thawed in the following ways:

- in a fan oven,
- in a microwave oven,
- at room temperature,
- in the refrigerator: the cold given off by the frozen food is used for cooling.

Ice maker

Safety instructions and warnings

- The ice maker is designed exclusively to make ice cubes in quantities required by a household and may only be operated with water suitable for this purpose.
- All repairs and work on the ice maker may only be carried out by customer service personnel or other trained personnel.
- **The first three batches of ice must not be consumed or used. This applies both to using the appliance for the first time and also to using it after it has not been used for a lengthy period of time. This ensures that the water supply is purged.**
- **The manufacturer cannot accept liability for damage caused by a faulty connection to the mains water supply.**
- The ice maker will only work if the combined refrigerator-freezer is connected to the electricity supply. It will only make ice cubes if the freezer compartment is operating.
- Ensure that the drawer is fully closed, as the ice maker can otherwise not produce ice cubes.

Bleeding the ice maker

To ensure that the ice maker works properly, the water supply line must be bled.

- Touch the IceMaker icon  so that the IceMaker LED  comes on.

- Open the top freezer drawer.

- Press the **ON/OFF** button on the ice maker housing for approx. 3 seconds. The LED above the button starts flashing.

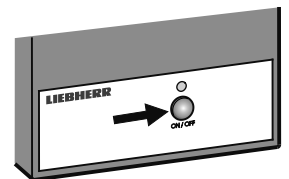

- Press the button again briefly. The LED flashes more quickly.
- Close the freezer drawer immediately.

The water supply valve opens for 25 seconds and pumps all the air out of the water supply system.

- Then the ice cube tray of the ice maker must be completely emptied. See the section **Activating the ice maker vacation state**.

- Finally, clean the ice cube bin. 

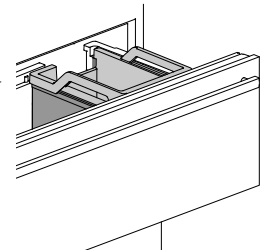

Switching the ice maker on

- Touch the **IceMaker icon**  so that the **IceMaker LED**  comes on.

After you start the ice maker for the first time, it may take up to 24 hours before the first ice cubes are ready.

The production capacity depends on the temperature inside the freezer compartment. The lower the temperature, the more ice cubes can be produced over a period of time.

The ice cubes fall out of the ice maker into the ice cube bin. When the ice reaches a certain level in the bin, the appliance stops producing ice automatically.

Switching the ice maker off

If you do not need any ice cubes, the ice maker can be switched off independently of the freezer compartment.

- Touch the **IceMaker icon**  so that the **IceMaker LED**  goes out.

The ice maker can also be switched on and off using the **ON/OFF** button at the ice maker housing.

Press the button for approximately 1 second.

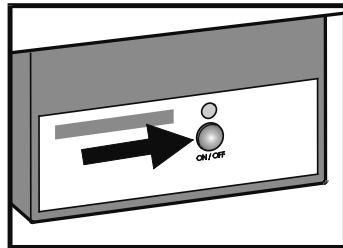

Ice maker vacation state

In case of longer vacations, the ice cube tray should be emptied.

By setting the ice maker into the vacation state, the tray will rotate down and no water remains in the tray.

The freezer drawer must be left open so that the surface of the tray dries up and no mould or unpleasant odours can occur.

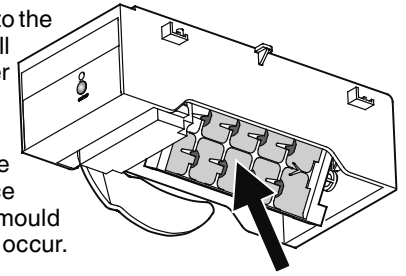

Activating the ice maker vacation state

Be sure the upper freezer drawer is completely closed and the ice cube bin is installed correctly.

- Activate setup mode by touching the **SuperFrost icon** for 5 seconds.

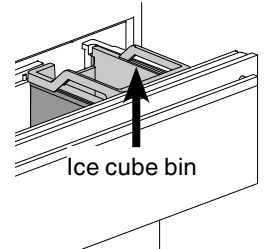

- Touch the freezer compartment **Down icon** until **1** appears in the display.

- Touch the **SuperFrost icon**.

- The display reads 

or 

depending on whether the ice maker is switched on or off.

- Touch the freezer compartment **Down icon**.

- The display reads 

- Touch the **SuperFrost icon**.

- The digit **1** flashes. 

The ice cube tray rotates down.

When the interior temperature appears in the display, the tray is in the down position and the ice maker is switched off automatically.

Defrosting

Refrigerator compartment

The refrigerator compartment defrosts automatically. The water that forms on the rear wall drains into a reservoir at the back of the appliance and evaporates automatically through the compressor heat.

Freezer compartment

The NoFrost system automatically defrosts the appliance. Any moisture arising collects on the evaporator and freezes, and is periodically defrosted and evaporated.

Cleaning

Before cleaning always switch off the appliance. Pull out the mains plug or switch off or unscrew the fuse.

- Clean the inside, equipment and outer walls with lukewarm water and a little detergent. Do not use abrasive or acid cleaners or chemical solvents.

Do not use steam cleaners because of the risk of injury and damage.

- Ensure that no cleaning water penetrates into the electrical components or ventilation grille.
- Dry all parts well with a cloth.
- Do not damage or remove the type plate on the inside of the appliance. It is very important for servicing purposes.

Cleaning the air filter

- Open the bottom freezer drawer and remove the ventilation grille by pulling forwards. The grille is supported magnetically so no tool is required for removing.

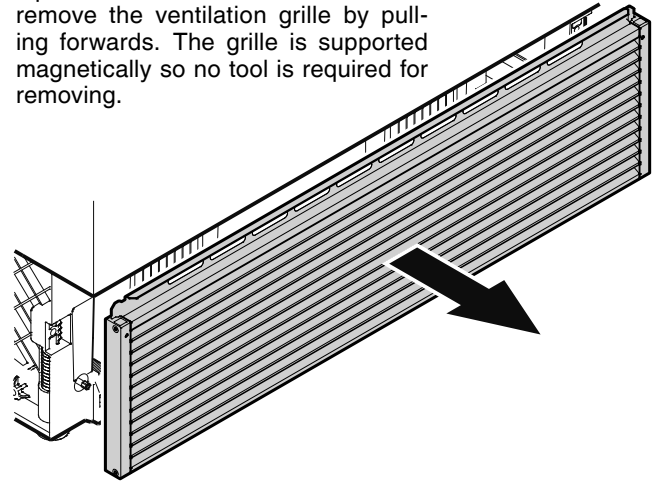

- Push down the button of the air filter, tilt to the front and remove.

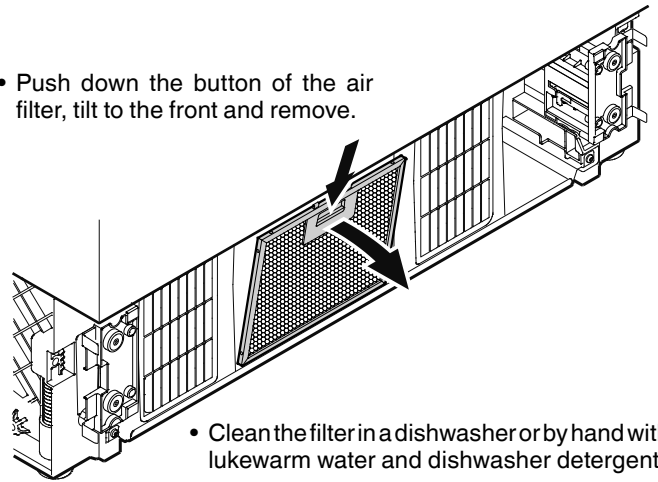

- Clean the filter in a dishwasher or by hand with lukewarm water and dishwasher detergent.
- Install the air filter in the reverse order.

- Install the ventilation grille.

The grille has bolts on the inside. These bolts must be inserted into the holes of the supports.

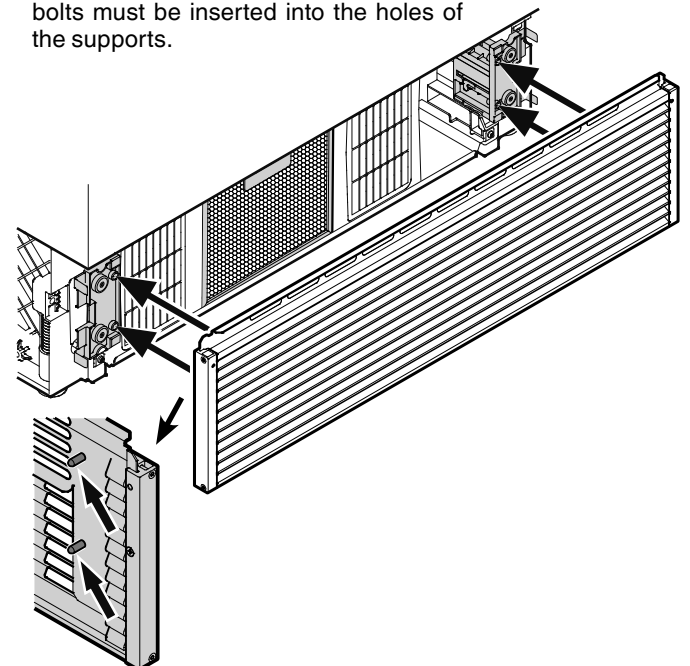

- Reset the air filter LED .

Refer to chapter **Setup Mode** -  = Reset air filter LED.

Setting up

- Avoid positioning the appliance in direct sunlight or near cookers, radiators and similar sources of heat.
- The floor on which the appliance stands should be horizontal and level.
- **Do not cover ventilation openings or grille.**
- Standard EN 378 specifies that the room in which you install your appliance must have a volume of 1 m³ per 8 g of R 600a refrigerant used in the appliance, so as to avoid the formation of inflammable gas/air mixtures in the room where the appliance is located in the event of a leak in the refrigerant circuit. The quantity of refrigerant used in your appliance is indicated on the type plate on the inside of the appliance
- Remove all transport packaging.

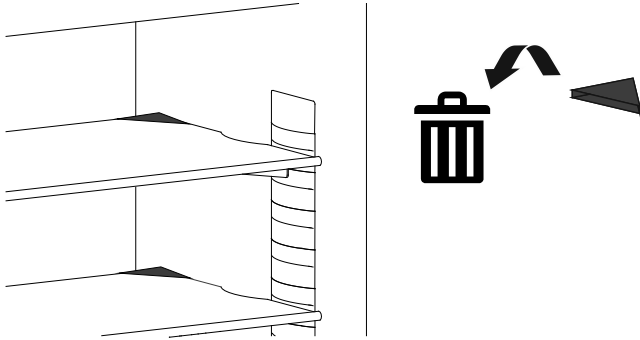

Electrical connection

Only operate the appliance with **alternating current (AC)**.

The permissible voltage and frequency are indicated on the type plate. The position of the type plate is shown in the section entitled **Description of the appliance** (in the operating instructions).

The socket must be properly earthed and protected by a fuse.

The tripping current of the fuse must be between 10 A and 16 A.

Do not connect the appliance using an extension cable or extension socket.

Do not use stand-alone inverters (conversion of direct current to alternating/three-phase current) or energy-saving plugs. Risk of damage to the electronic control system!

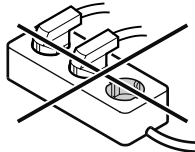

Appliance venting

The required air flow is directed through the plinth.

It is important to use the provided ventilation grille for the ventilation opening.

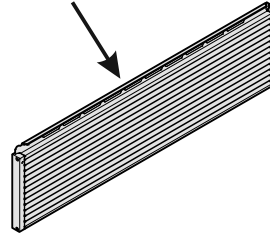

This opening must not be covered.

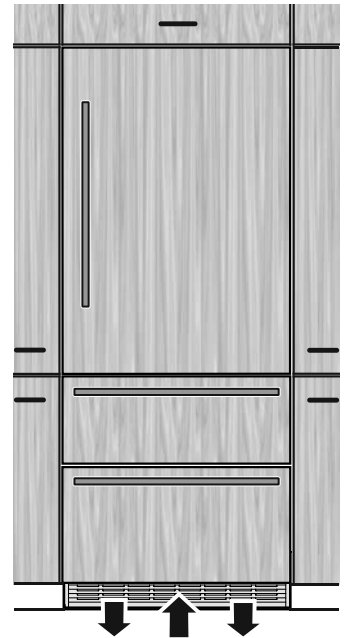

Door swing clearance

Please allow for door swing clearance at locations next to a wall.

The illustrated measurement is without mounted door panel.

Be sure to add your panel thickness and handle depth to this measurement in order to avoid interferences.

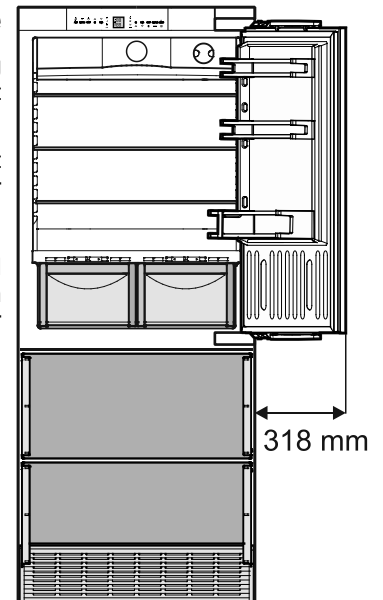

Appliance dimensions

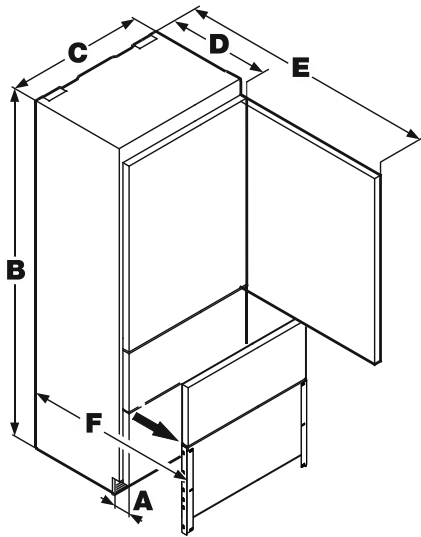

- A = 76 mm
- B = 2024 mm
- C = 757 mm
- D = 610 mm
- E = 1412 mm
- F = 952 mm

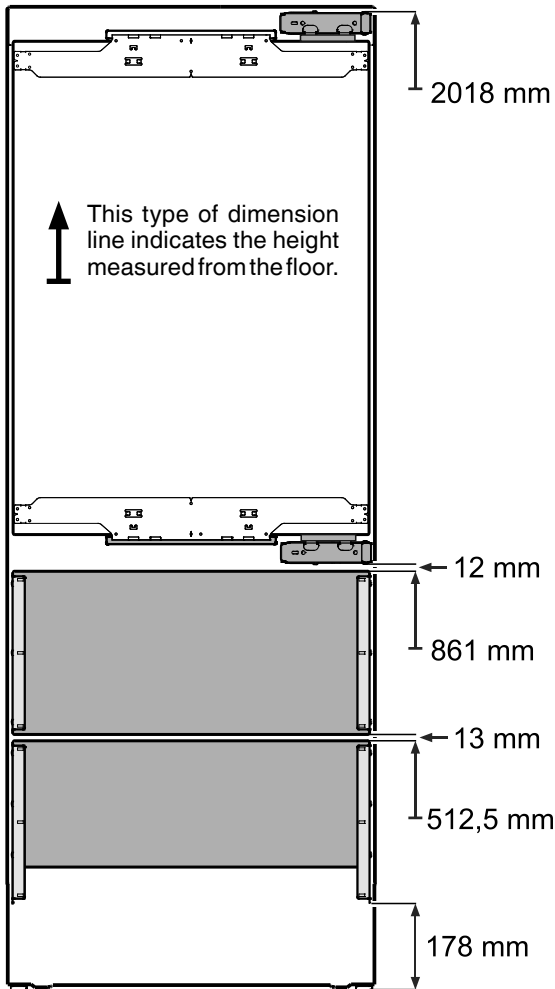

Installation dimensions

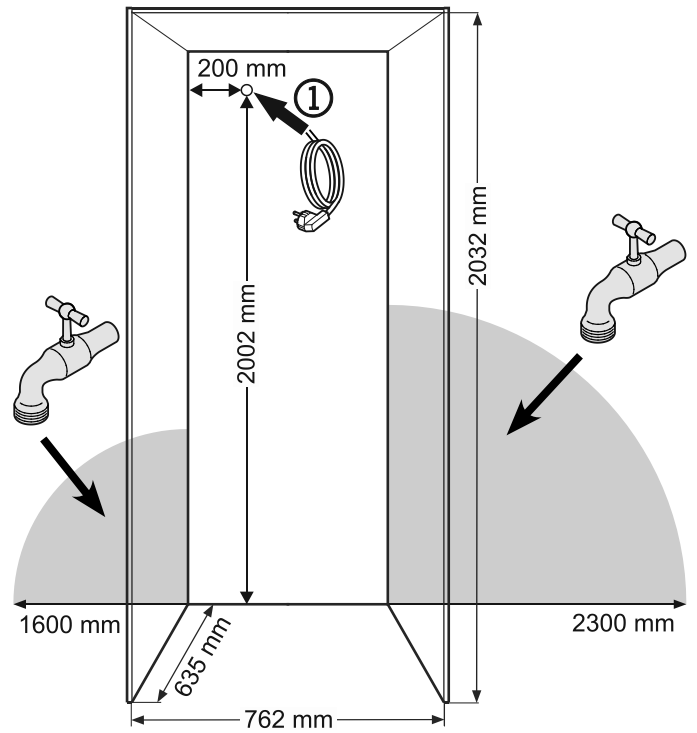

(1) In this area, the power cord comes out of the appliance rear. Free length of the power cord = **2200 mm**. Choose the position of the socket considering these specifications.

The socket must not be situated behind the appliance and must be easily accessible.

The ice maker is fitted in the freezer compartment of the combined refrigerator-freezer. It must be connected to the mains water supply to work.

The water shut-off valve must be positioned within the areas marked in grey.

Important

Do not install the shut-off valve behind the appliance.

WARNING!

The water shut-off valve must not be positioned directly above the socket!

The gap between the water shut-off valve and the socket must comply with the regulations of the country in which the appliance is used!

Mounting the anti-tipping device



WARNING!

The supplied anti-tipping bracket must be installed in all cases. This prevents the appliance from tipping over when the fully loaded door is opened.

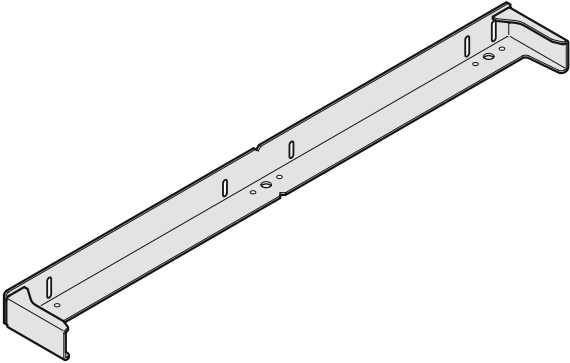

CAUTION!

Ensure that there are no electric cables or water pipes in the wall section to which the anti-tipping bracket is to be secured. These could be damaged during installation.

Installation

1. Mark the centre line of the appliance on the floor.
Align the anti-tipping bracket centre to the centre line.

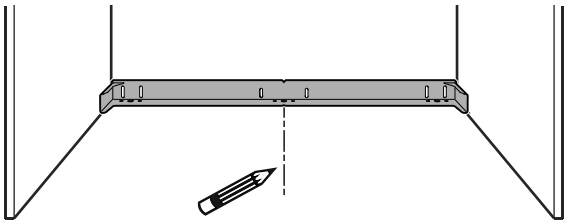

2. Secure the anti-tipping bracket. See section entitled "Anti-tipping device mounting options".

Important!

If the floor slopes down sideways, the anti-tipping bracket must be fitted horizontally. Lay down spacers in the appropriate positions.

Anti-tipping device mounting options

Securing to the wall using 3 screws.

When securing the anti-tipping device to concrete walls, use suitable plugs.

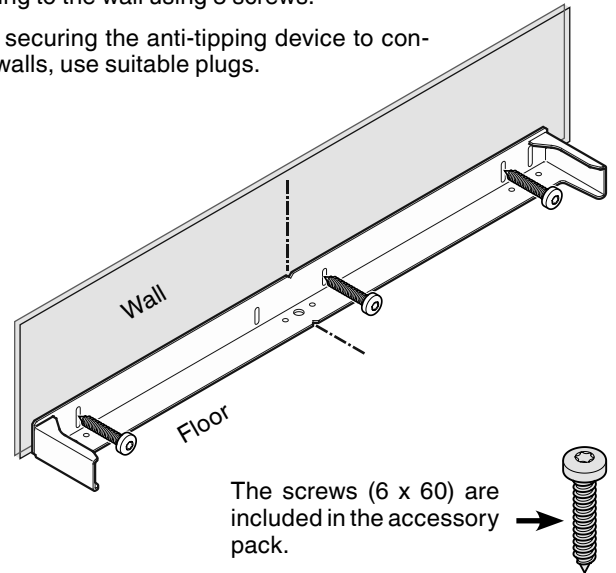

Securing to the floor using 3 screws.

When securing the anti-tipping device to a concrete floor, use suitable plugs.

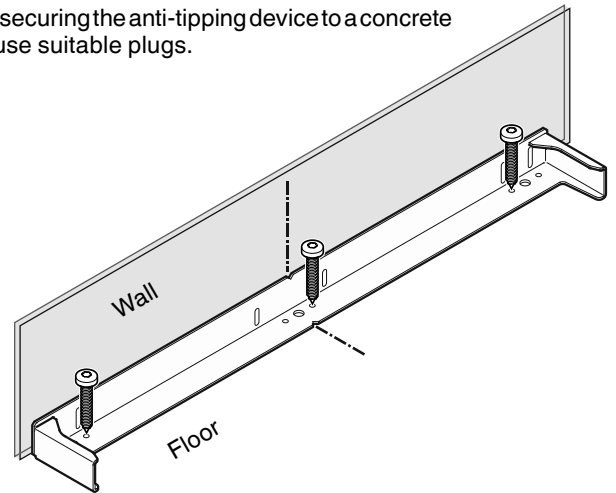

Connection to the water supply

Safety instructions and warnings

- Do not connect to the water supply while the combined refrigerator-freezer is connected to the electricity supply.
- **The connection to the mains water supply may only be made by trained personnel.**
- **The water quality must comply with the drinking water directives of the country in which the appliance is used.**
- The ice maker is designed exclusively to make ice cubes in quantities required by a household and may only be operated with water suitable for this purpose.
- All repairs and work on the ice maker may only be carried out by customer service personnel or other trained personnel.
- **The manufacturer cannot accept liability for damage caused by a faulty connection to the mains water supply.**

Water pressure

The **water pressure** must be between **0.15 and 0.6 MPa (1.5 - 6 bar)**.

Important!

If the water filter is inserted in the appliance, the **water pressure** must lie between **0.3 and 0.6 MPa (2.8 - 6 bar)**.

If the water pressure with the inserted water filter is too low, this may cause the ice maker to malfunction.

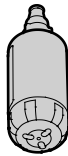

The water supply to the appliance must be through a cold water pipe that can withstand the operating pressure and complies with the hygiene regulations.

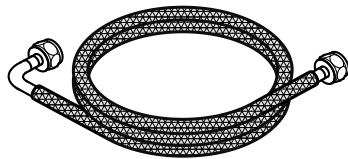

For this, use the stainless steel hose supplied (length 3 m).

Installing the appliance

1. Place the appliance in front of the installation recess.

2. Apply cover strips above, between and below the securing plates on the side walls of the appliance.

- Cut the cover strips to the right length for this purpose.
- Fit the adhesive cover strips leaving a gap of 6 mm to each securing plate.

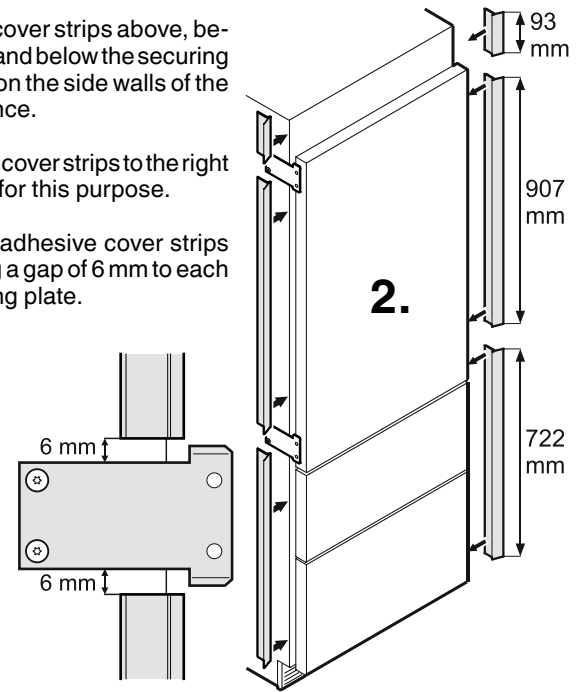

3. Insert the bent section of the hose through the opening at the right side of the appliance.

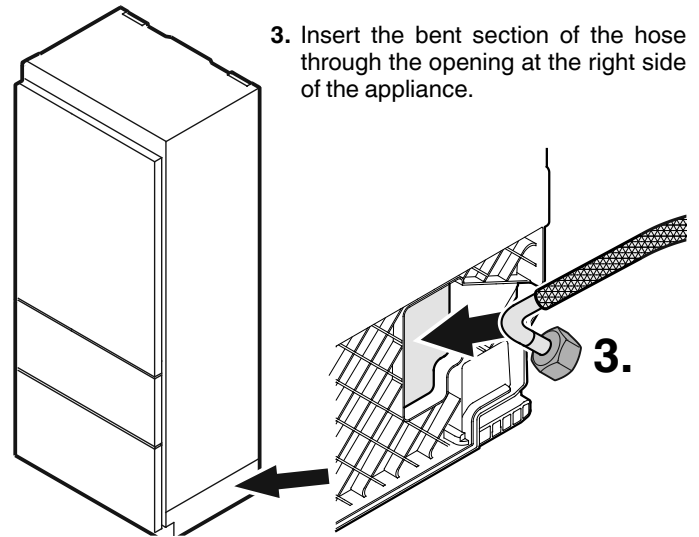

4. Connect the hose to the solenoid valve at the front side of the appliance.

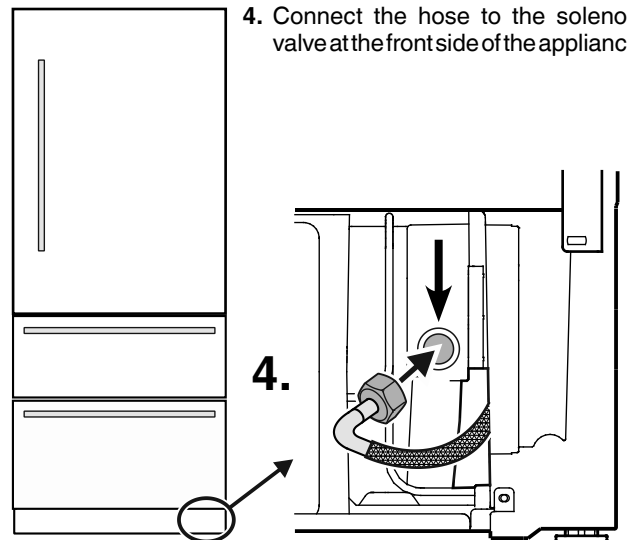

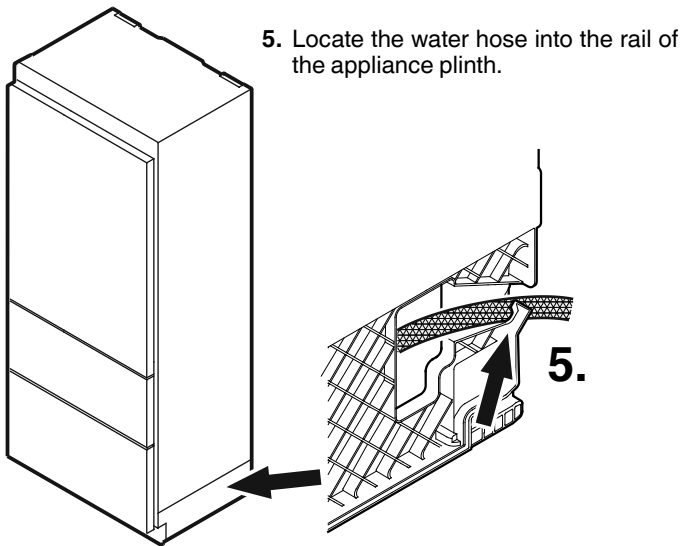

5. Locate the water hose into the rail of the appliance plinth.

- 6. Route the mains cable towards the socket.
- 7. Route the water hose towards the water shut-off valve.



WARNING!

Do not connect the appliance to the power supply until the installation has been completed.



CAUTION!

Lay the mains cable and the water hose in such a way that they will not be damaged when the appliance is slid into the installation recess.

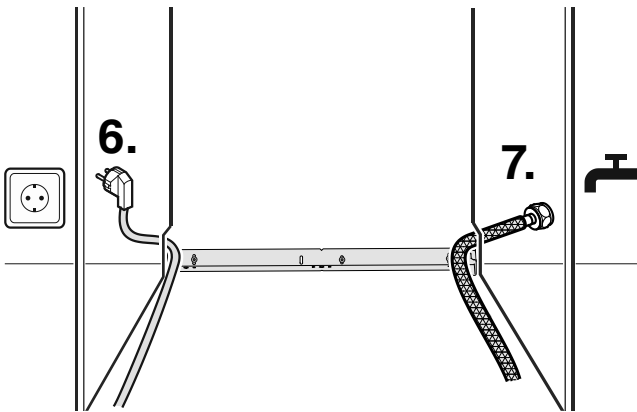

CAUTION!
Mains cable/Water line trapped between anti-tipping device and rear of the appliance. Mains cable/Water line crushed. Install cable holders. Insert mains cable/water line in cable holders.

IMPORTANT!
These steps are only necessary if the socket or water line are on the opposite side.

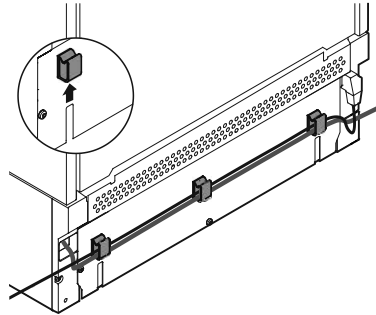

Install the cable holders on the rear of the appliance. Insert mains cable/water line in cable holders.

Slide the appliance into the recess. To avoid damage, pull the mains cable and water line backwards at the same time with slight tension.

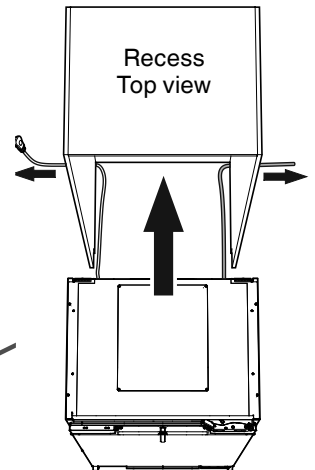

IMPORTANT!
After sliding the appliance into the recess, plug in the appliance and check its function. Then unplug it again.

- 8. Push the appliance slowly into the recess so that the appliance plinth engages in the anti-tipping bracket.

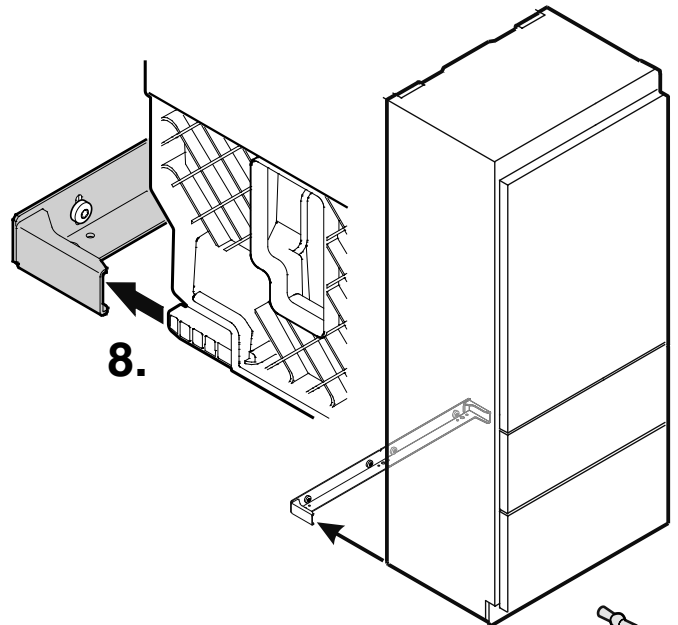

- 9. Fill the hose with water and connect to the shut-off valve.

Open the shut-off valve and check the system for leakage.

Important!

After the ice maker has been switched on, the water supply system must be bled. See the section **Bleeding the ice maker** in the operating instructions.

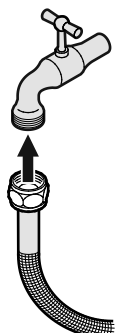

Levelling the appliance

1. Adjust the height of the appliance at the front by twisting the adjustable feet (1). Use the spanner provided. Turn the spanner anticlockwise to raise the appliance front and clockwise to lower it. Position the spanner accordingly (1).
2. Adjust the height of the appliance at the rear by turning the adjusting bolts (2).

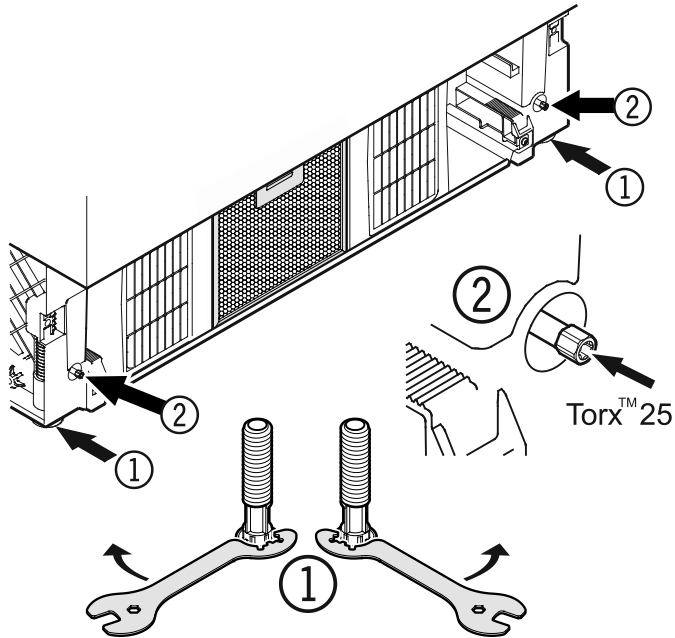

Fastening the appliance in the recess

Once in the recess, secure the appliance to the body of the unit using the securing plates (4 x 16 screws).

Then click the covers supplied into place.

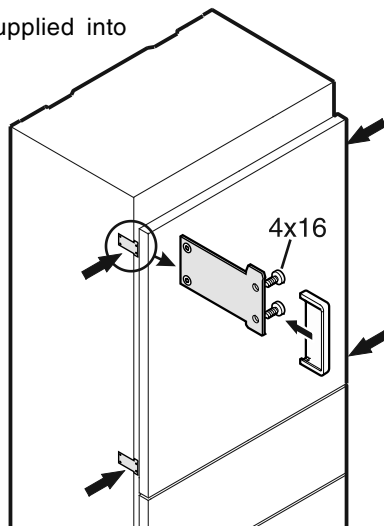

Adjusting the refrigerator door

The lateral tilt of the refrigerator door can be adjusted if required. Undo screws (1). Adjust the lateral tilt using the grub screw (2) (Allen key A/F 2.5).

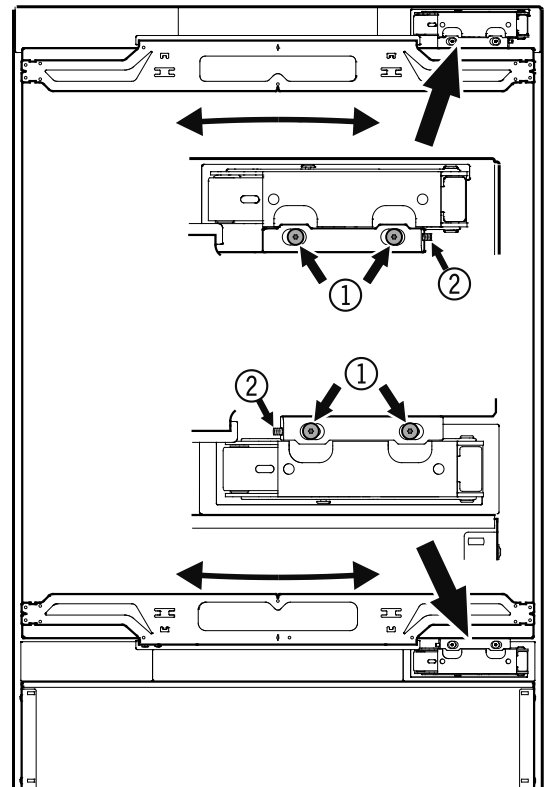

Adjusting the front of the drawer

If required, the front of the freezer drawers can be adjusted.

Transfer the screws shown in the illustration (on the left- and right-hand sides of the freezer drawer) individually to the long slots below.

Tighten the screws once the front of the drawer is in the right position.

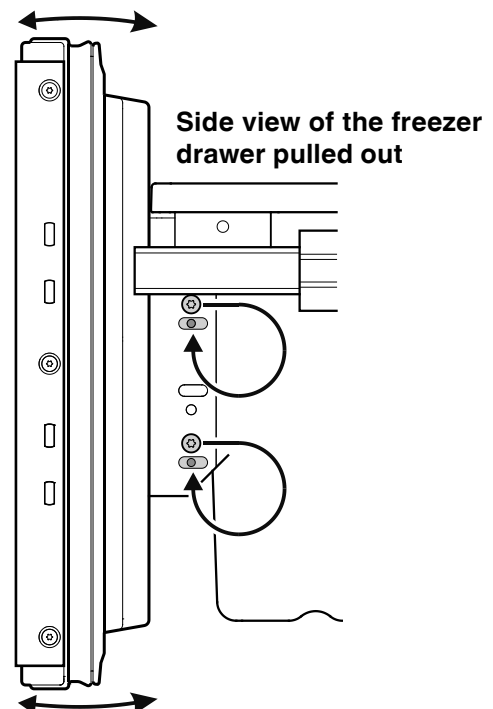

Mounting the ventilation grille

Pull out the bottom freezer drawer.

1. Remove the protective film from the dust filter. Insert the filter at the bottom, press the button down and click the filter into place.

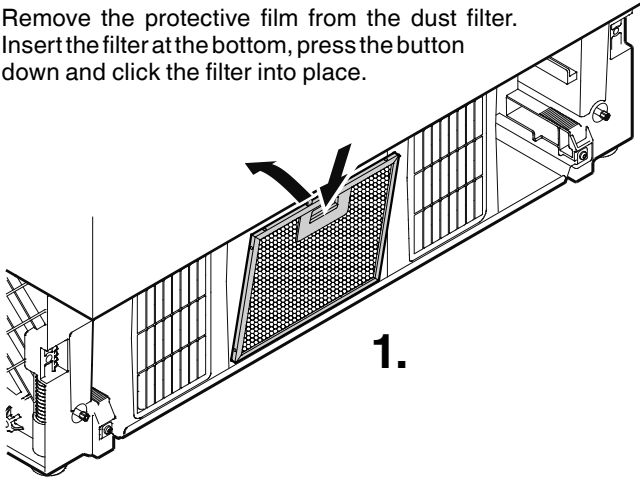

2. Remove the locking pins of both supports. The supports are provided with the appliance accessory pack.

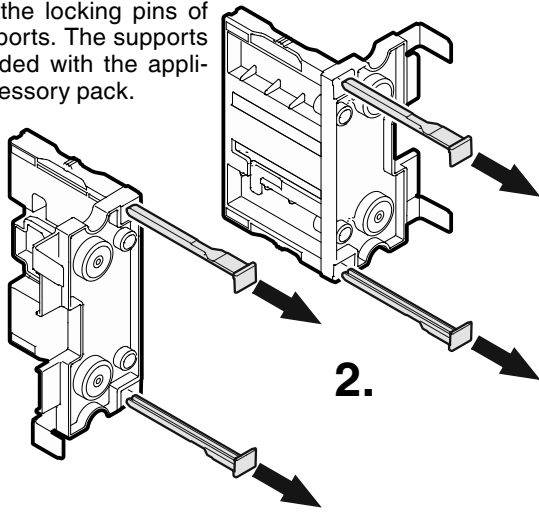

3. Insert the supports for the ventilation grille on the left and right sides in the motor compartment.

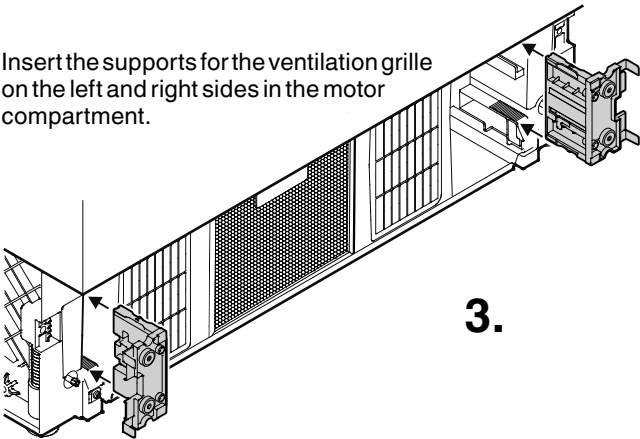

4. The front edge of the brackets is flush with the front of the ventilation grille. Adjust the supports accordingly.

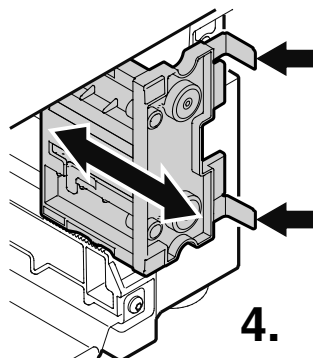

5. Insert the locking pins to block the supports.

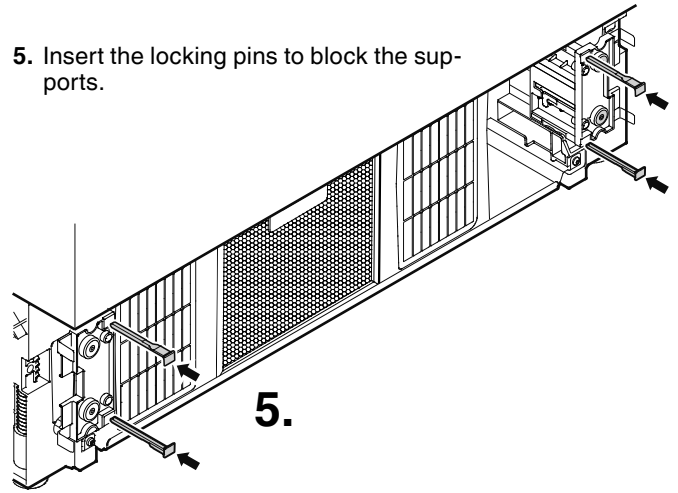

6. Install the ventilation grille.

The grille has bolts on the inside (see detail in the illustration below). These bolts must be inserted into the holes of the supports.

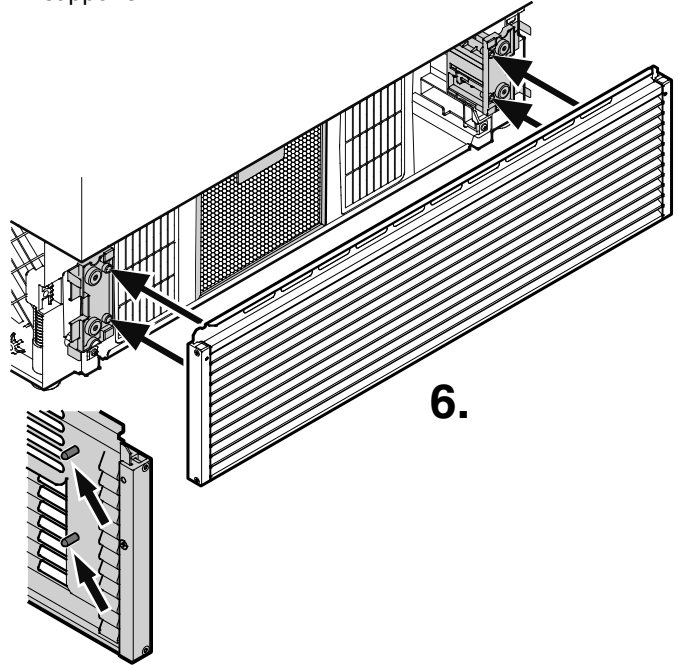

7. Adjust the height of the ventilation grille.

- Loosen the grub screws at the front of the grille (Allen key A/F 2.5).
- Adjust the ventilation grille to the desired height.
- Tighten the grub screws.

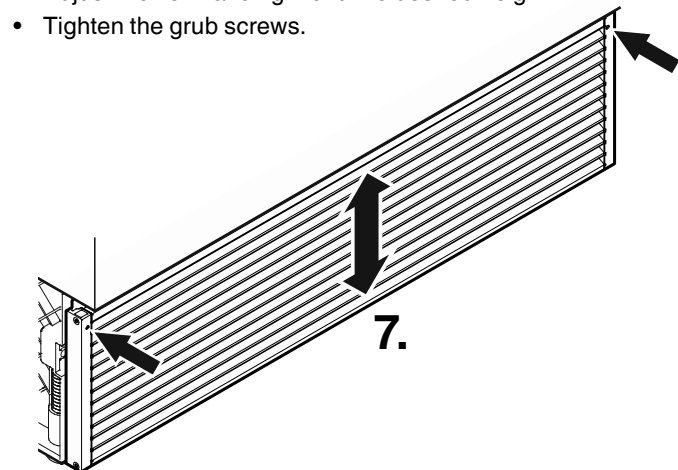

Removing the mounting accessories from the refrigerator door

Remove the cover (1) and unscrew the top and bottom attachment brackets (2) from the refrigerator door. These attachment brackets will be mounted onto the refrigerator door panel.

Important!

The securing nuts are needed for re-mounting the pre-assembled door panel onto the refrigerator door.

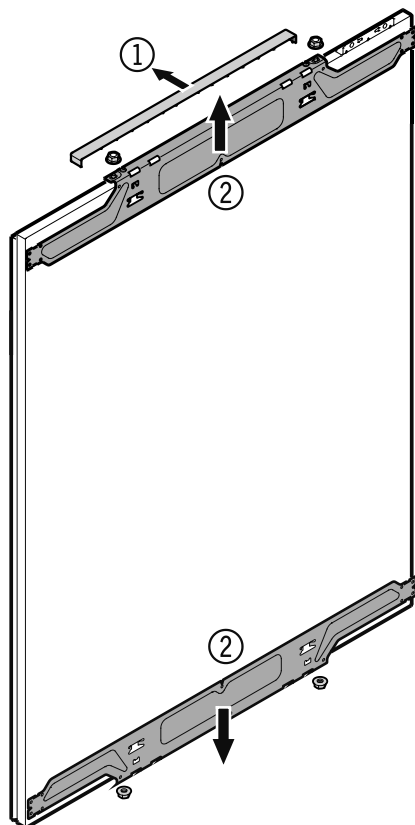

Removing the mounting accessories from the freezer drawers

Unscrew the attachment brackets (3) from the freezer drawers. These attachment brackets will be mounted onto the freezer panels.

Important!

The screws are needed for re-mounting the pre-assembled freezer panels onto the freezer drawers.

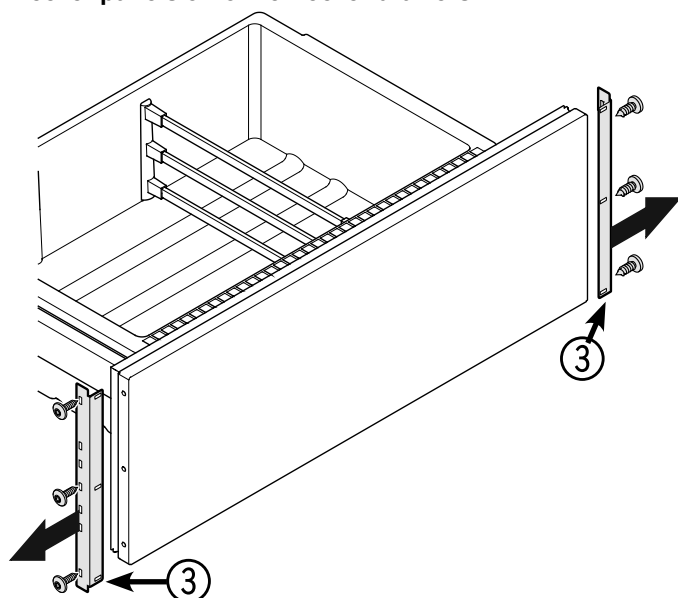

Panel dimensions

Min. panel thickness = 16 mm
Max. panel thickness = 20 mm

Maximum panel weight

Refrigerator panel = 27 kg
Freezer drawer panel = 12 kg

Internal door panel

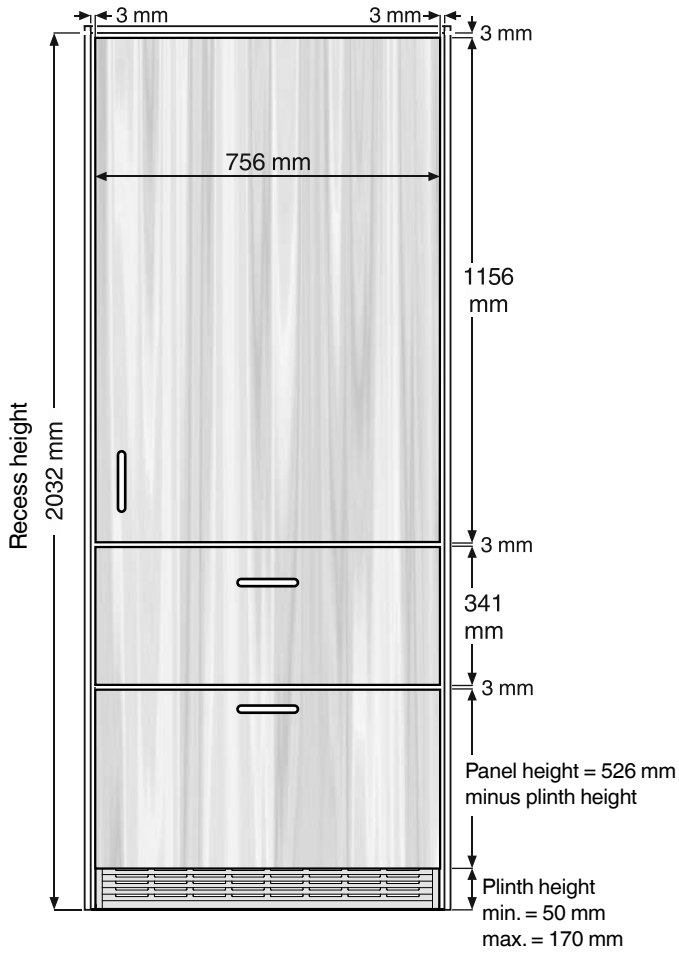

External door panel

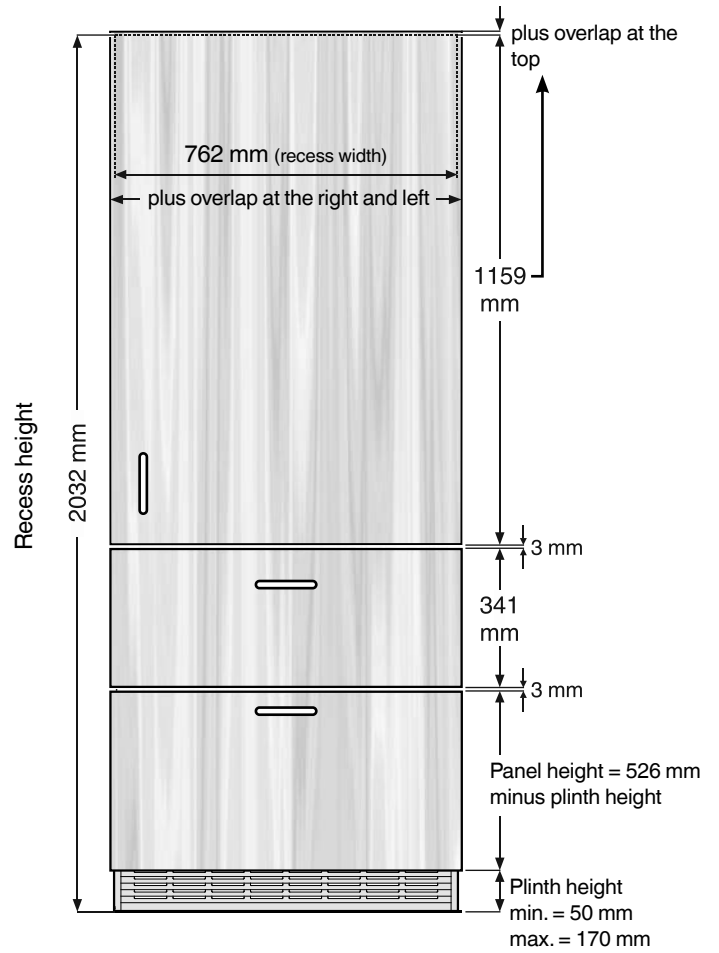

Mounting the attachment brackets onto the door panels

1. Draw a line 1041 mm from the bottom edge of the door panel.
2. Draw a further line 107.5 mm from the bottom edge of the door panel.
3. Align one of the refrigerator door attachment brackets to the top line, as shown in the illustration below, and secure with at least 6 screws (4 x 14).
4. Align the second refrigerator door attachment bracket to the bottom line, as shown in the illustration below, and secure with at least 6 screws (4 x 14).
5. Secure each of the attachment brackets that have been removed from the freezer drawers using 3 screws (4 x 14), as shown in the illustration below.

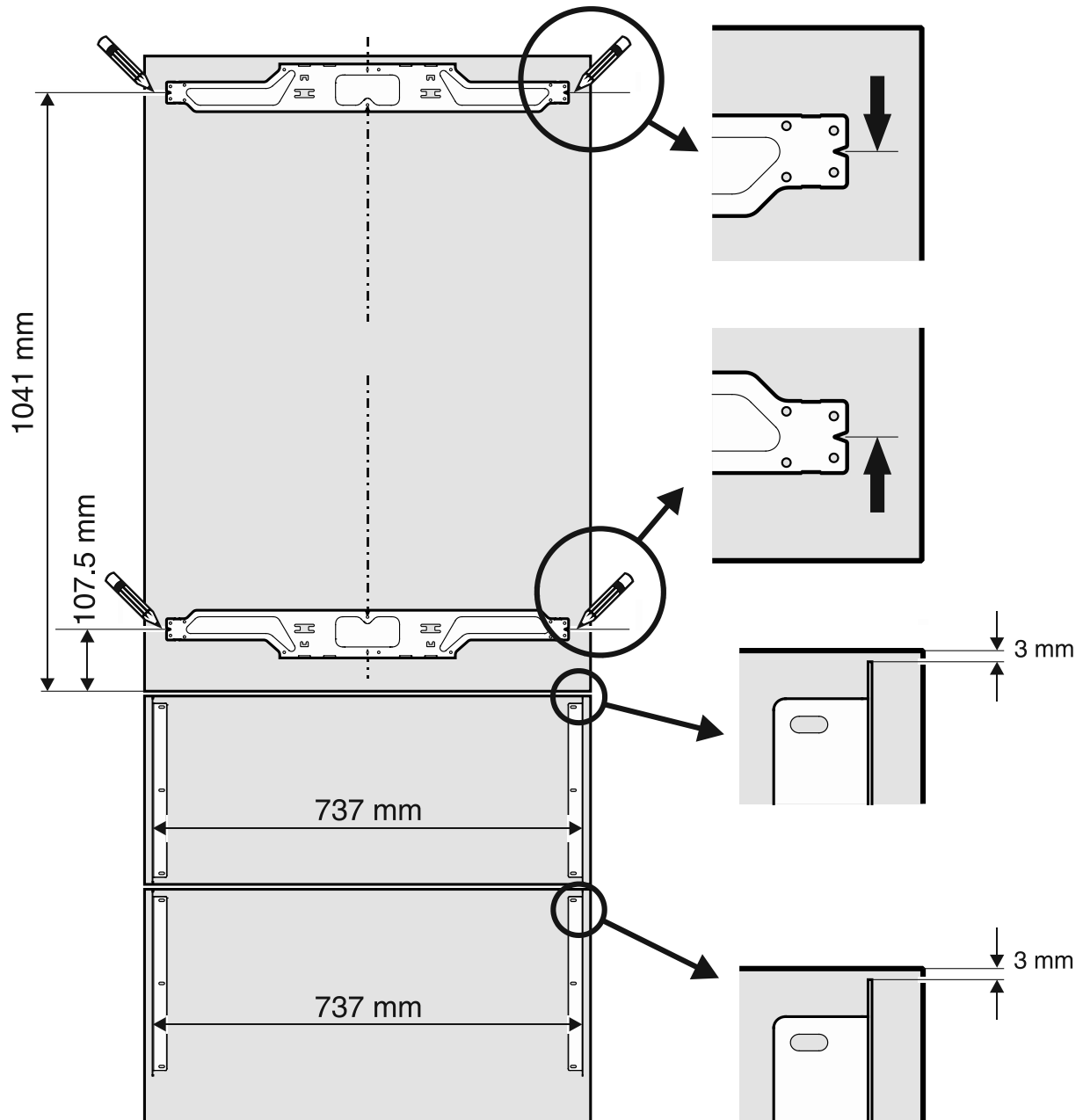

Mounting the refrigerator panel

1. Screw in the adjusting pins on the underside of the refrigerator door completely (**fig. A**).

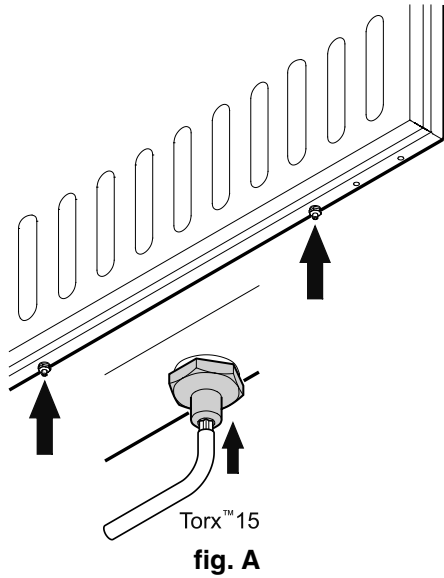

2. Open the refrigerator door and suspend the refrigerator panel on the top adjusting pins (**fig. B**).
3. Screw securing nuts onto the adjusting pins and slightly tighten.

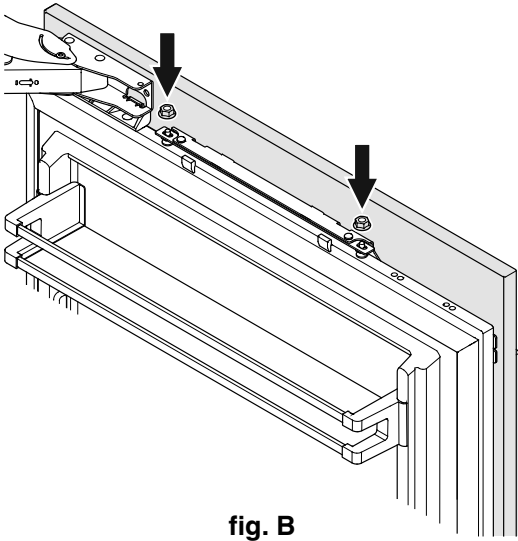

4. Close the refrigerator door and check the height of the panel.
5. Adjust the height of the panel if necessary. Undo the securing nuts and use the adjusting pins to adjust (**fig. C**).

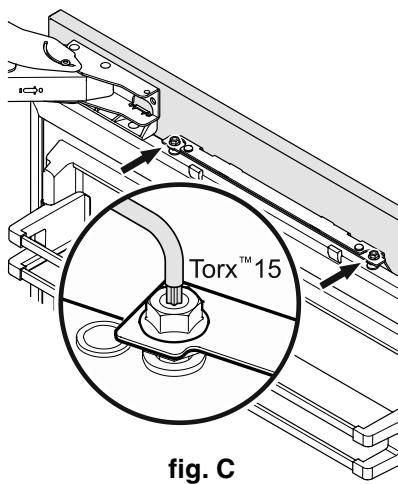

6. Adjust the panel horizontally (using the long slots in the attachment bracket) (**fig. D**).
7. Tighten the securing nuts.

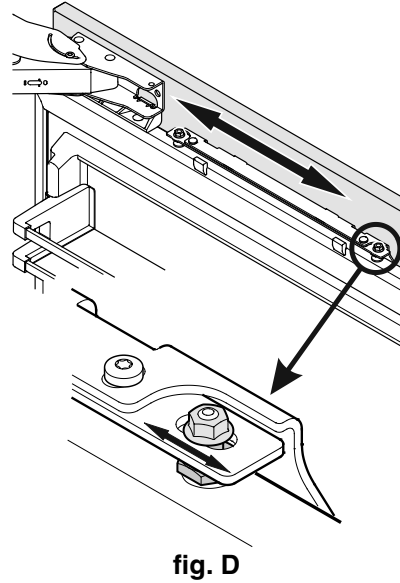

8. Unscrew the adjusting pins (bottom of the refrigerator door) until these touch the attachment bracket (**fig. E**).

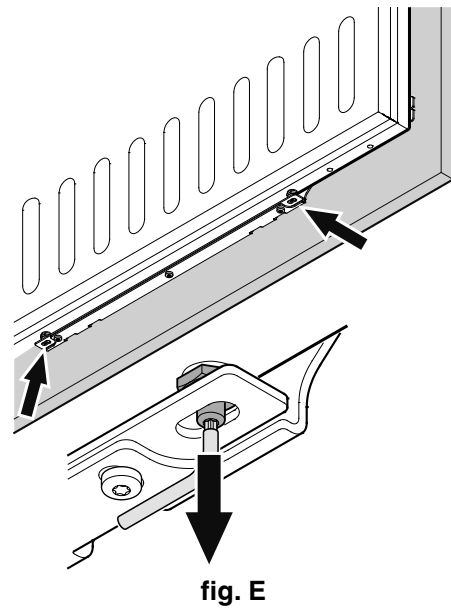

9. Screw on the securing nuts and tighten (**fig. F**).

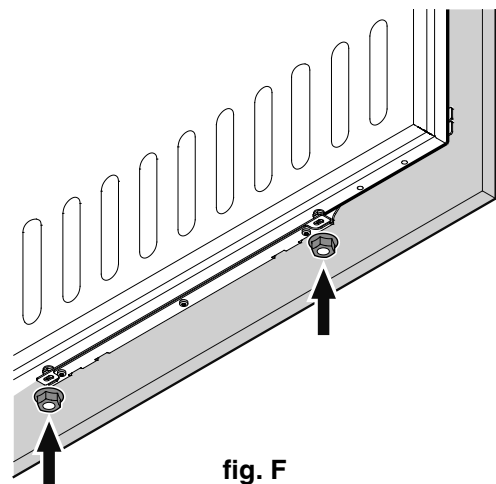

10. Undo the three screws on the top of the attachment bracket, adjust the door panel as illustrated in **fig. G** and then retighten the screws. The same procedure can be carried out for the bottom attachment bracket.

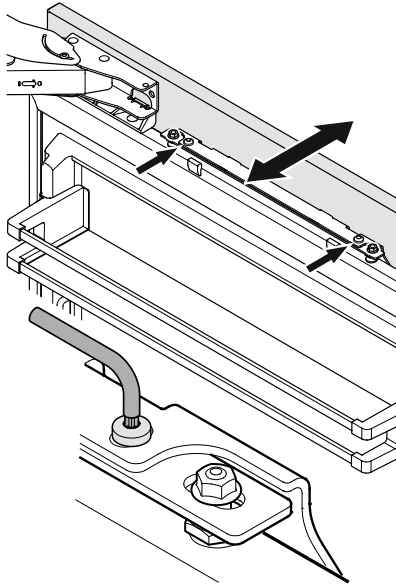

fig. G

11. Click the top and bottom covers (1) into place (**fig. H**).

Insert the cover strip provided (2) between refrigerator door and panel.

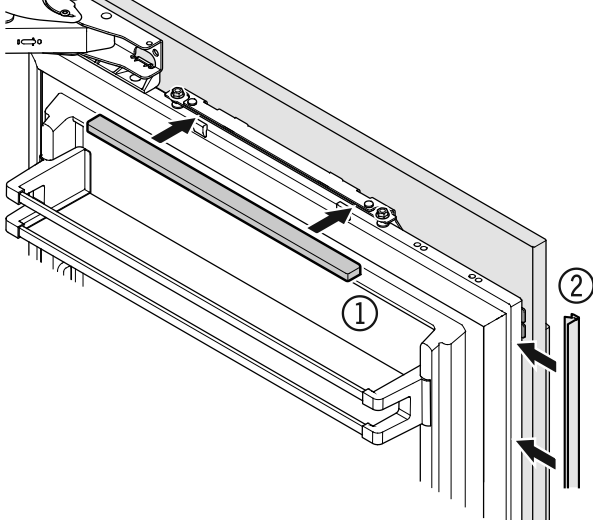
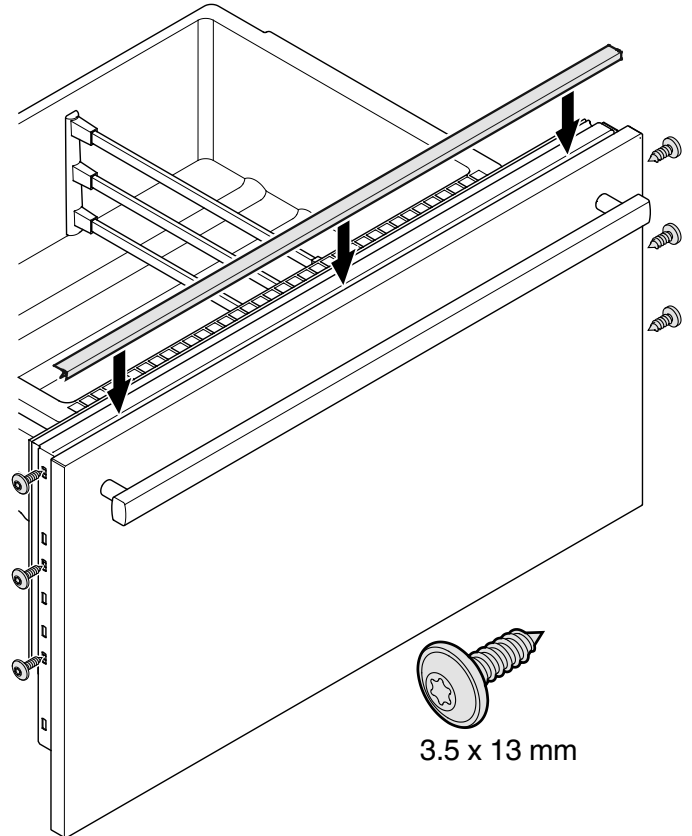

fig. H

Mounting the freezer panels

1. Pull out the top freezer drawer and screw on the pre-assembled panel.
The same screws must be used as those used to screw on the attachment brackets (**see section entitled "Removing the mounting accessories from the freezer drawers"**).
2. Close the freezer drawer and check the position of the panel. Adjust the height of the panel by undoing the left and right screws. Tighten the screws.
3. Pull out the bottom freezer drawer and mount the panel in the same way.
4. For both drawers, cover the gap between the drawer and the panel with the cover strips supplied. Remove the protective film from the strip and insert into the gap at the top.



3.5 x 13 mm

Changing over door hinges

Door hinges may only be changed by a trained expert.

⚠ WARNING!

Do not try to change over the door hinges yourself. The refrigerator door hinges are fitted with strong closing springs. If the hinge accidentally snaps shut, this can lead to serious injury.



Liebherr Hausgeräte Lienz GmbH

Dr.-Hans-Liebherr-Strasse 1

A-9900 Lienz

Österreich

www.liebherr.com

