

---

# L 507–L 518 Stereo

---

## LIEBHERR

Wheel loaders



**Generation**  
6

**Engine**  
Stage V

**Tipping load**  
3,750 kg–6,550 kg

## Performance

Compact and easily manoeuvrable –  
the best partner in confined spaces

## Economy

Intelligent machine design –  
low costs with high output

## Reliability

A reliable partner –  
robust and durable machines

## Comfort

Compact engineering skill –  
when technology combines comfort and safety

## Maintainability

Savings in both time and costs –  
thanks to quick and simple maintenance



### L 507 Stereo

**Tipping load, articulated**

3,750 kg

**Bucket capacity**

0.9 m<sup>3</sup>

**Operating weight**

5,550 kg

**Engine output**

50 kW/68 HP



## L 509 Stereo

**Tipping load, articulated**  
4,430 kg  
**Bucket capacity**  
1.2 m<sup>3</sup>  
**Operating weight**  
6,390 kg  
**Engine output**  
54 kW/73 HP

## L 514 Stereo

**Tipping load, articulated**  
5,750 kg  
**Bucket capacity**  
1.5 m<sup>3</sup>  
**Operating weight**  
8,860 kg  
**Engine output**  
76 kW/103 HP

## L 518 Stereo

**Tipping load, articulated**  
6,550 kg  
**Bucket capacity**  
1.7 m<sup>3</sup>  
**Operating weight**  
9,190 kg  
**Engine output**  
76 kW/103 HP

# Performance

---



## **Compact and easily manoeuvrable – the best partner in confined spaces**

The specially developed steering system of the Stereoloader enables quick and efficient manoeuvring. Even confined spaces are no problem for these sturdy all-rounders. Faster work cycles, high payloads, and high machine availability result in excellent handling capacity.



### Unique machine design

- The specially developed stereo steering system provides outstanding manoeuvrability and flexibility
- The combination of articulated steering and steered rear axle enables a reduced articulation angle of only 30° with stereo steering
- A tight turning radius means maximum manoeuvrability
- Fast and efficient work even in confined spaces



### Compact and stable

- Maximum stability on all terrain due to a lower articulation angle
- The compact design produces a very low centre of gravity and low operating mass
- The transportation of high payloads with a low operating weight is made possible thanks to the intelligent machine design



### Application-optimised lift arms

- Z-bar kinematics work with maximum force in all applications
- High breakout forces in the lower lift arm range combined with strong holding forces in the upper lift arm range increase productivity in all applications
- Optimised load guidance in fork operation over the entire lifting range for safe and precise work and sensitive control



### Versatile

- A wide range of working attachments increase versatility and make the Stereoloader a high performing and profitable all-rounder
- Easily changeable tools and attachments increase productivity
- Ideal machine for all areas of application such as road construction, municipal services, and as a reliable helper on a diverse range of construction sites

# Economy

---



## Intelligent machine design – low costs with high output

Safe, practical, and compact – the Stereoloader will make a decisive contribution to your commercial success. The demand-controlled cooling system reduces fuel consumption and noise pollution, which is beneficial for both the operator and the immediate environment. For more speed under the wheels, there is the Speeder version of the Stereoloader.



### Powerful travel drive

- Hydrostatic Liebherr travel drive
- Outstanding traction even when driving on difficult terrain
- Stereo: continuous acceleration without loss of traction
- Speeder: powerful acceleration up to the maximum speed with the help of a 2-stage automated transmission



### Demand-controlled cooling

- Demand-controlled cooling saves fuel and reduces noise pollution
- The fan drive automatically provides the exact amount of cooling power needed
- Helps reduce operating costs and increase profitability



### Speeder version to go even faster

- Ideal for operations with high travel speeds and long driving distances
- The L 507 and L 509 models reach a top speed of up to 38 km/h
- The L 514 and L 518 models reach a top speed of up to 40 km/h
- Time savings increase profitability



### Solidlink

- Hydraulic quick coupler with integrated automatic hydraulic coupling system (available as an option for L 507-L 509)
- Hydraulic attachments changed within seconds direct from the cab
- Change is fully automatic, safe, and with no fluid leakage
- Time saving due to convenience results in higher productivity and saves time and costs

# Reliability

---



## A reliable partner – robust and durable machines

Tried and tested over decades with proven excellence – the “stereo concept” is still unique in wheel loaders today and delivers maximum performance even under the toughest operating conditions. Specially developed components, sophisticated technology, and the highest quality ensure maximum reliability and availability.



### High performance and durable components

- Decades of experience in the development, design and production of components is reflected in their robustness and durability
- Components are ideally matched to one another for maximum performance
- High Liebherr quality standards ensure reliability, even in the toughest operating conditions



### Optimal cooling capacity

- Cooling air is drawn in at the side behind the operator's cab and flows through the entire engine compartment
- The L 507 and L 509 models have cross-cooling (air flows across the engine compartment)
- The L 514 and L 518 models have diagonal flow cooling (air flows diagonally through the engine compartment)
- Demand-controlled cooling for improved cooling performance and reliable operation



### Protective equipment options

- The optional equipment – such as the reversible fan drive, lint filter for the radiator and the coarse-mesh radiator – all protect the cooling system from contamination
- Particularly recommended for very dust-intensive applications
- Improves the cooling performance while minimising cleaning requirements
- Reduced maintenance times lead to more efficient and cost-effective operations



### Work without interruption

- Diesel oxidation catalysts (DOC) and diesel particulate filters (DPF) are installed for exhaust gas treatment, and lower exhaust emissions
- Additional selective catalytic reduction (SCR) on the L 514 and L 518
- Uninterrupted work due to passive and active particulate filter regeneration during operation
- Longer intervals between regenerations saves fuel and reduces operating costs

# Comfort

---



## Compact engineering skill – when technology combines comfort and safety

A cab where you can really feel good – the design of which is optimally adapted to the day-to-day requirements of the operator. The spacious and ergonomically designed layout and the easy handling of the Stereoloader provides the perfect conditions for comfortable and productive working.

L 507 / L 509



#### Modern cab design for greater productivity

- The modern ergonomic cab design enables focused working with less fatigue
- The displays, controls, and the operator's seat are perfectly coordinated and form an ergonomic unit
- Numerous storage compartments and well-thought-out solutions provide plenty of space on all sides of the operator's cab
- Simple and intuitive in operation the Stereoloader provides excellent on-site versatility

L 514 / L 518



#### Keep an eye on everything – for hazard-free work

- The extensive use of glass in the operator's cab provides excellent all-round visibility of the working attachment and operating area
- The engine bonnet was designed with visibility in mind and this, together with the optional reversing camera, ensures excellent overview
- The highest degree of safety can be ensured even in confined spaces



#### Precise and sensitive – the Liebherr control lever

- All of the machine's working and driving functions can be controlled precisely and safely using the Liebherr control lever
- Hydraulic working tools are controlled proportionally through the Liebherr control lever with mini-joystick
- Hydraulic tools can therefore be controlled very ergonomically and with the utmost sensitivity



#### Sophisticated design for more comfort

- Thanks to the side window that can be opened by 180°, there is much better air circulation in the operator's cab and it is easier to communicate with those outside of the cab
- The damped articulated pendulum joint compensates for uneven ground and ensures excellent stability and maximum comfort

# Maintainability



## Simple and quick maintenance – means time and cost savings for you

Intelligent installation of components, quicker and easier access to the engine compartment, as well as maximum efficiency in every last detail are key to effective maintenance work. All installed parts which need to be serviced can be reached safely and comfortably from the ground. This saves time and money.



#### Safe and open service access

- The entire engine compartment can be accessed easily by opening just one hood
- All points for daily maintenance work are accessible from the ground
- Both factors reduce downtime



#### Low maintenance due to intelligent design

- Simple and safe maintenance ensures less downtime
- Less radiator contamination due to its well-thought-out position directly behind the operator's cab



#### Increased efficiency down to the smallest detail

- Maximum efficiency thanks to optimum coordination between components
- Easily accessible filler pipe enables quick and easy filling
- All test points and fluid levels are immediately visible when looking around the machine



#### Liebherr-Service

- Effective and timely support from a well-staffed service network
- Fast and safe service provision by qualified service specialists

# Focus on safety and comfort

---

## Lift arms

---

Strong and robust – the powerful Z-bar kinematics have impressive hydraulic components, robust and durable lift arms, and a strong steel construction. Safe lifting and loading without the need for manual re-adjustment and no loss of load, as well as quick and impressive positioning of loading material. The intelligent machine design ensures risk-free transportation of loads even on uneven ground.



## Stability and tip resistant

---

Durable and manoeuvrable – the unique articulated pendulum joint compensates for uneven ground and results in a comfortable and stable ride. Additional stability and maximum manoeuvrability due to a tight turning radius is provided by the unique stereo steering with an articulation angle of only 30°. Maximum productivity is ensured by an optimal ratio between operating mass and tipping load.



## Operator's cab

Excellent visibility and comfort – the ergonomically optimised cab design enables comfortable and less tiring work. The large glazed area and the visually-optimised engine bonnet design provide an unobstructed view in all directions. The Stereoloader's simple handling makes it easy to learn and means the operator can quickly get to grips with the machine. This saves time and increases versatility.

## Assistance systems

Intelligent helpers – the optional innovative assistance systems for the L 514 and L 518 models offer comprehensive solutions to optimise safety and comfort, supporting the operator and thus enhancing performance. The simple handling and intuitive operation enable safe, efficient, and thus more economical machine operation.

## Technology

Versatile and effective – the highly efficient, hydrostatic travel drive results in performance-oriented and cost-optimised operation. The Speeder variants offer significantly more travel speed and result in work being performed even faster. A wide range of working attachments mean that the machines can be used in a very versatile and universal way. To enhance operational safety, all maintenance points are quickly and safely visible from the ground.

# Technical data

L 507 - L 509

## Diesel engine

	L 507 Stereo	L 507 Speeder L 509 Stereo L 509 Speeder
<b>Diesel engine</b>	4TNV98C	4TNV98CT
Design	Water-cooled in-series diesel engine	Water-cooled turbocharged in-series diesel engine
Cylinder inline	4	4
Fuel injection process	Electronic Common Rail high-pressure injection	
Output to ISO 9249 ~ SAE J1349	kW / HP 48 / 65 at RPM 2,400	52 / 71 2,400
Rated output to ISO 14396 / ECE-R.120	kW / HP 50 / 68 at RPM 2,400	54 / 73 2,400
Nominal speed	2,400	2,400
Max. torque to ISO 14396	Nm 235 at RPM 1,560	280 1,800
Displacement	litres 3.32	3.32
Bore / Stroke	mm 98 / 110	98 / 110
<b>Stage V</b>		
Harmful emissions values	According to regulation (EU) 2016 / 628	
Emission control	Closed diesel particle filter system	
<b>Air cleaner system</b>	Dry type filter with main and safety element	
<b>Electrical system</b>		
Operating voltage	V 12	12
Capacity	Ah 100	100
Alternator	V / A 12 / 80	12 / 80
Starter	V / kW 12 / 3	12 / 3

## Driveline

	L 507 Stereo L 509 Stereo	L 507 Speeder L 509 Speeder
<b>Hydrostatic driveline</b>		
Design	Continuous, swash plate type variable flow pump and variable axial piston motor in closed loop circuit	2-speed automated gearbox, swash plate type variable flow pump and variable axial piston motor in closed loop circuit
Filtration	Suction return line filter for closed circuit	
Control	By travel and inching pedal. The inching pedal makes it possible to control the tractive and thrust forces steplessly at full engine speed. The Liebherr control lever is used to control forward and reverse travel	
<b>Travel speed range</b>	Speed range 1: 0-6 km/h Speed range A1-2: 0-20 km/h forward and reverse	Speed range 1: 0-18 km/h Speed range A1-2: 0-38 km/h*

\* Configuration, tyres and mounting tools can influence the maximum speed.

## Brakes

	L 507 Stereo L 509 Stereo	L 507 Speeder L 509 Speeder
<b>Service brake</b>	Wear-free service brake due to hydrostatic driveline, applied to all four wheels and additional hydraulically activated drum brake	Wear-free service brake due to hydrostatic driveline, applied to all four wheels and additional dual-circuit brake system, drum brake and wet multi-disc brake located in the front axle
<b>Parking brake</b>	Negative brake system on the drum brake	Negative brake system in the front axle acting on the wet multi-disc brakes

The braking system meets the requirements of the ISO 3450.

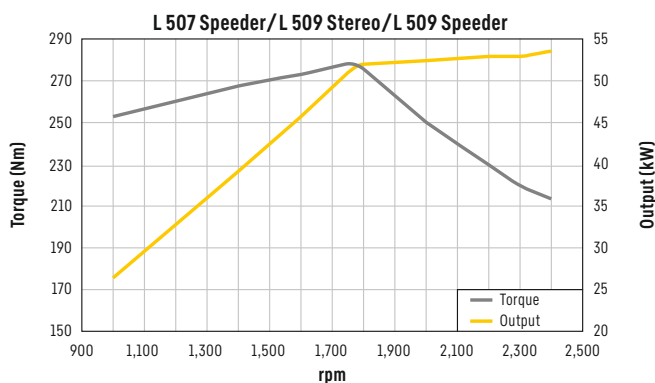
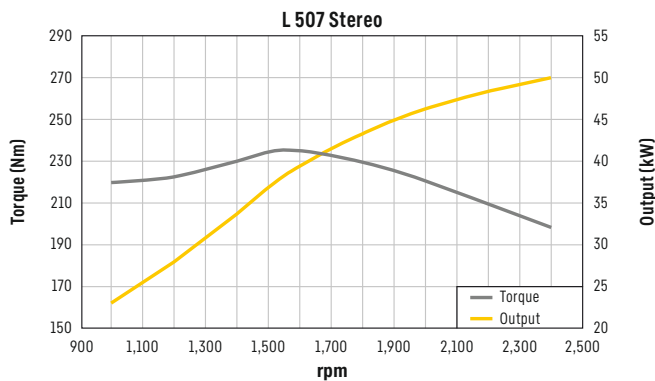

## Axles

	L 507 Stereo L 509 Stereo	L 507 Speeder L 509 Speeder
<b>Four-wheel drive</b>		
<b>Front axle</b>	Fixed	
<b>Rear axle</b>	Axle pivot steering, fixed	
Height of obstacles which can be driven over	mm	370
<b>Differentials</b>	with all four wheels remaining in contact with the ground	
	Automatic multi-disc limited slip differentials with 45% locking action in both axles	100% differential lock in front axle, manually engaged
<b>Reduction gear</b>	Planetary final drive in wheel hubs	
<b>Track width</b>	1,510 mm with tyres indicated as standard (L 507) 1,630 mm with tyres indicated as standard (L 509)	

## Steering

<b>Design</b>	Stereo steering system, hydraulic servo power steering. Central oscillating frame articulation with damper element in combination with rear-axle pivot steering	
<b>Angle of articulation</b>	30° to each side	
<b>Angle of oscillation - centre-pivot steering</b>	8° to each side	
<b>Max. pressure</b>	bar	180

## Attachment hydraulics

	L 507	L 509
<b>Design</b>	Gear pump to supply the hydraulic and steering systems (via priority valve)	
<b>Cooling</b>	Hydraulic oil cooling using thermostatically controlled fan	
<b>Filtration Control</b>	Suction return line filter in the hydraulic reservoir	
<b>Lifting function</b>	Liebherr control lever, hydraulically operated, 1st and 2nd additional hydraulic function are electrically, proportional controlled	
	Lifting, neutral, lowering	
	Float position controlled by Liebherr control lever with detent, automatic hoist kick out optional	
<b>Tilt function</b>	Tilt back, neutral, dump	
	Automatic bucket return to dig optional	
<b>Max. flow</b>	l/min.	70
<b>Max. pressure</b>	bar	230

## Attachment

	L 507	L 509
<b>Geometry</b>	Powerful Z-bar linkage with tilt cylinder, hydraulic quick hitch as standard	
<b>Cycle time at nominal load</b>	ZK	ZK
Lifting	s	4.9
Dumping	s	1.7
Lowering (empty)	s	3.5

## Operator's cab

<b>Design</b>	Elastic mounted, noise-proof cab ROPS roll over protection per EN ISO 3471 / EN 474-1 FOPS falling objects protection per EN ISO 3449 / EN 474-1, Cat. II Operator's door with 180° opening angle with rigid window, fold-out window on right with 12° gap opener or 180° opening, single-pane safety glass ESG, heated rear window ESG, all windows are tinted. Continuously adjustable steering column optional
<b>Liebherr operator's seat</b>	5 way adjustable, vibration-damped operator's seat "Standard" (mechanically sprung, adjustable to operator's weight), Liebherr control lever mounted into the operator's seat as standard
<b>Cab heating and ventilation</b>	Fresh / recirculated air mode, cab heating via cooling water, arrangement of the air nozzles ensures quick defrosting and defogging of the windows, electrically heated rear window
<b>Vibration emissions</b>	
Hand / arm vibrations	≤ 2.5 m/s <sup>2</sup> , according with ISO 5349-1:2001
Whole-body vibrations	≤ 0.5 m/s <sup>2</sup> , complies with technical report ISO/TR 25398:2006
Measuring inaccuracy	According with standard EN 12096:1997

## Sound level

	L 507	L 509
<b>Sound pressure level to ISO 6396</b>		
L <sub>PA</sub> (inside cab)	dB(A)	73
<b>Sound power level to 2000/14/EC</b>		
L <sub>WA</sub> (surround noise)	dB(A)	101

## Capacities

	L 507 Stereo	L 507 Speeder	L 509 Stereo	L 509 Speeder
<b>Fuel tank</b>	l	90	90	90
<b>Engine oil (inclusive filter change)</b>	l	10.2	10.2	10.2
<b>Transmission</b>	l	0.8	1.3	0.8
<b>Coolant</b>	l	9	9	9
<b>Front axle / differential</b>	l	4.7	3.7	6.3
<b>Rear axle / differential</b>	l	3.5	4.3	5.7
<b>Front axle / wheel hubs</b>	l	1.4	1.4	1.4
<b>Rear axle / wheel hubs</b>	l	1.4	1.4	1.4
<b>Hydraulic tank</b>	l	65	65	65
<b>Hydraulic system, total</b>	l	102	102	102

# Dimensions

## Z-bar linkage

L 507 - L 509

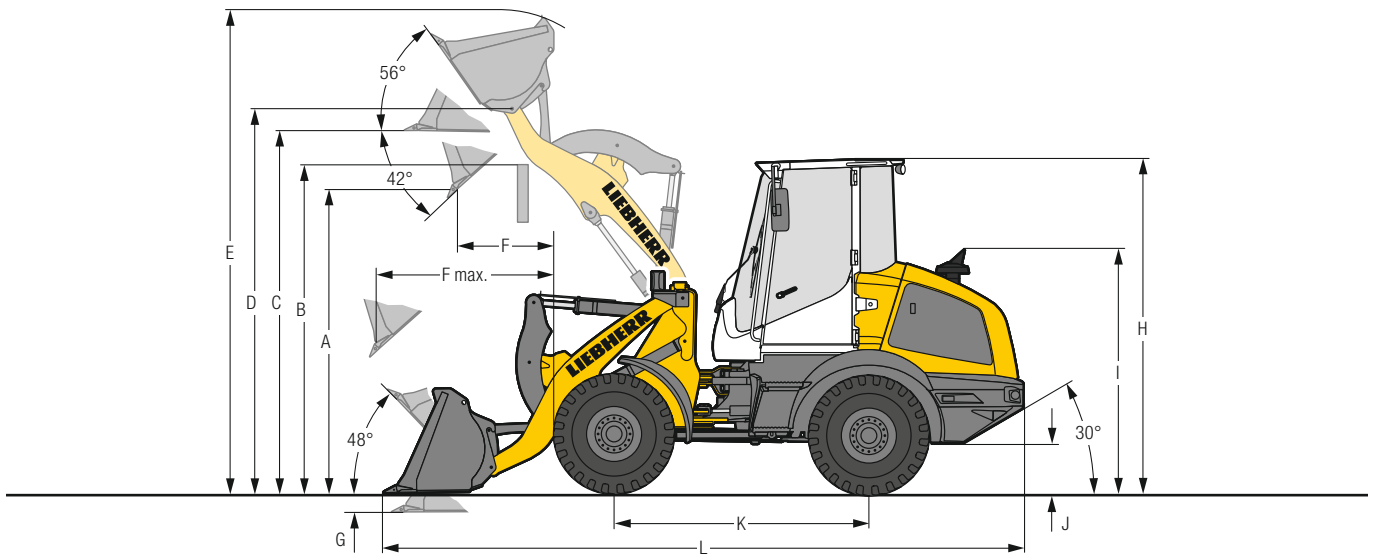

### Excavation bucket

	L 507		L 509	
	STD	ZK-QH	STD	HL
Geometry	ZK-QH		ZK-QH	ZK-QH
Cutting tools	T		T	T
Lift arm length	mm	2,150	2,250	2,560
Bucket capacity according to ISO 7546 **	m <sup>3</sup>	0.9	1.2	1.0
Specific material density	t/m <sup>3</sup>	1.8	1.8	1.8
Bucket width	mm	2,050	2,330	2,100
A Dumping height at max. lift height and 42° discharge	mm	2,550	2,645	3,145
B Dump-over height	mm	2,870	3,000	3,450
C Max. height of bucket bottom	mm	3,015	3,145	3,585
D Max. height of bucket pivot point	mm	3,215	3,345	3,785
E Max. operating height	mm	4,040	4,260	4,680
F Reach at max. lift height and 42° discharge	mm	815	910	875
F max. Max. reach at 42° discharge	mm	1,500	1,645	1,935
G Digging depth	mm	80	95	110
H Height above operator's cab	mm	2,780	2,810	2,810
I Height above exhaust	mm	2,030	2,060	2,060
J Ground clearance	mm	285	295	295
K Wheelbase	mm	2,150	2,300	2,300
L Overall length	mm	5,495	5,815	6,170
Turning circle radius over tyres	mm	3,520	3,760	3,760
Turning circle radius over outside bucket edge	mm	3,885	4,225	4,325
Breakout force (SAE)	kN	48	55	59
Tipping load, straight *	kg	4,070	4,850	4,100
Tipping load, fully articulated *	kg	3,750	4,430	3,750
Operating weight *	kg	5,550	6,390	6,630
Tyre size		365/70R18 L2	405/70R18 L2	

\* The figures shown include the above tyres, all lubricants, a full fuel tank, the ROPS/FOPS cab and the operator.

Different tyres and optional equipment will change the operating weight and tipping load. (Tipping load, fully articulated according to ISO 14397-1)

\*\* Actual bucket capacity may be approx. 10% larger than the calculation according to ISO 7546 standard. The degree to which the bucket can be filled depends on the material - see page 22.

- STD = Standard lift arm length
- HL = High Lift
- ZK-QH = Z-bar linkage incl. quick hitch
- T = Welded-on tooth holder with add-on teeth

# Attachment

## Light material bucket

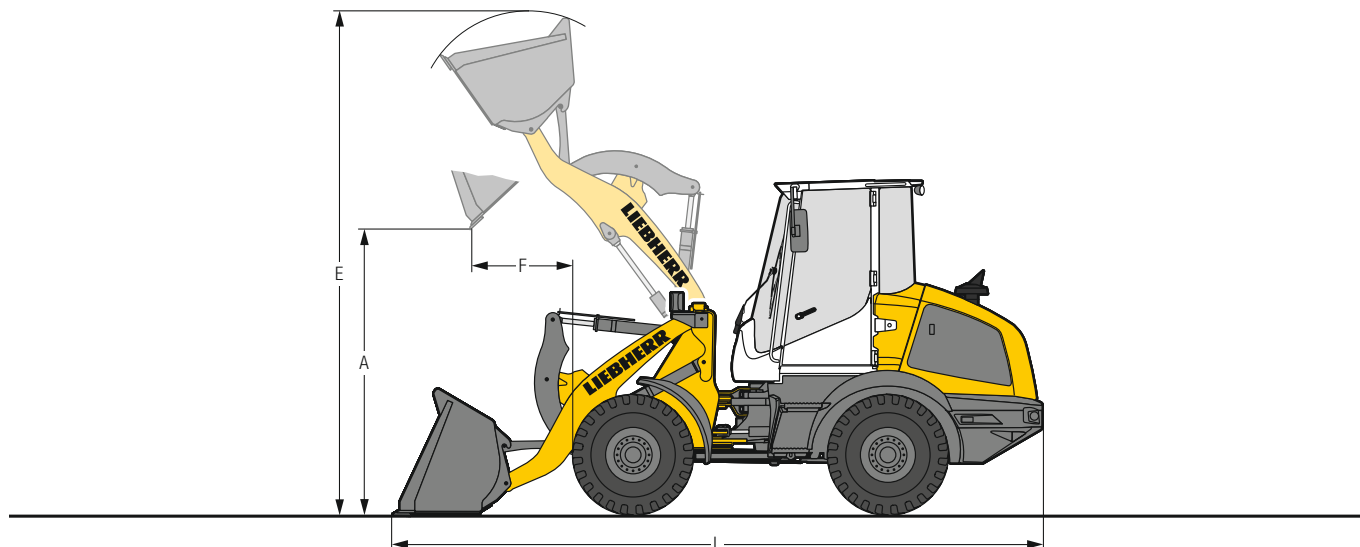

### Heavy material density

	L 507			L 509	
	STD	STD	STD	STD	HL
Geometry	ZK-QH	ZK-QH	ZK-QH	ZK-QH	ZK-QH
Cutting tools	BOCE	BOCE	BOCE	BOCE	BOCE
Bucket capacity	m <sup>3</sup> 1.2	1.6	1.6	2.0	1.6
Specific material density	t/m <sup>3</sup> 1.4	1.0	1.3	1.0	1.0
Bucket width	mm 2,330	2,400	2,400	2,400	2,400
A Dumping height at max. lift height	mm 2,510	2,420	2,550	2,465	3,005
E Max. operating height	mm 4,130	4,205	4,330	4,485	4,780
F Reach at maximum lift height	mm 840	870	935	1,040	950
L Overall length	mm 5,465	5,580	5,820	5,960	6,210
Tipping load, straight*	kg 3,920	3,825	4,700	4,620	3,955
Tipping load, fully articulated*	kg 3,575	3,490	4,275	4,200	3,600
Operating weight*	kg 5,675	5,730	6,455	6,465	6,765
Tyre size	365/70R18 L2			405/70R18 L2	

\* The figures shown include the above tyres, all lubricants, a full fuel tank, the ROPS / FOPS cab and the operator.

Different tyres and optional equipment will change the operating weight and tipping load. (Tipping load, fully articulated according to ISO 14397-1)

STD = Standard lift arm length

HL = High Lift

ZK-QH = Z-bar linkage incl. quick hitch

BOCE = Bolt-on cutting edge

# Attachment

## 4 in 1 bucket

L 507 - L 509

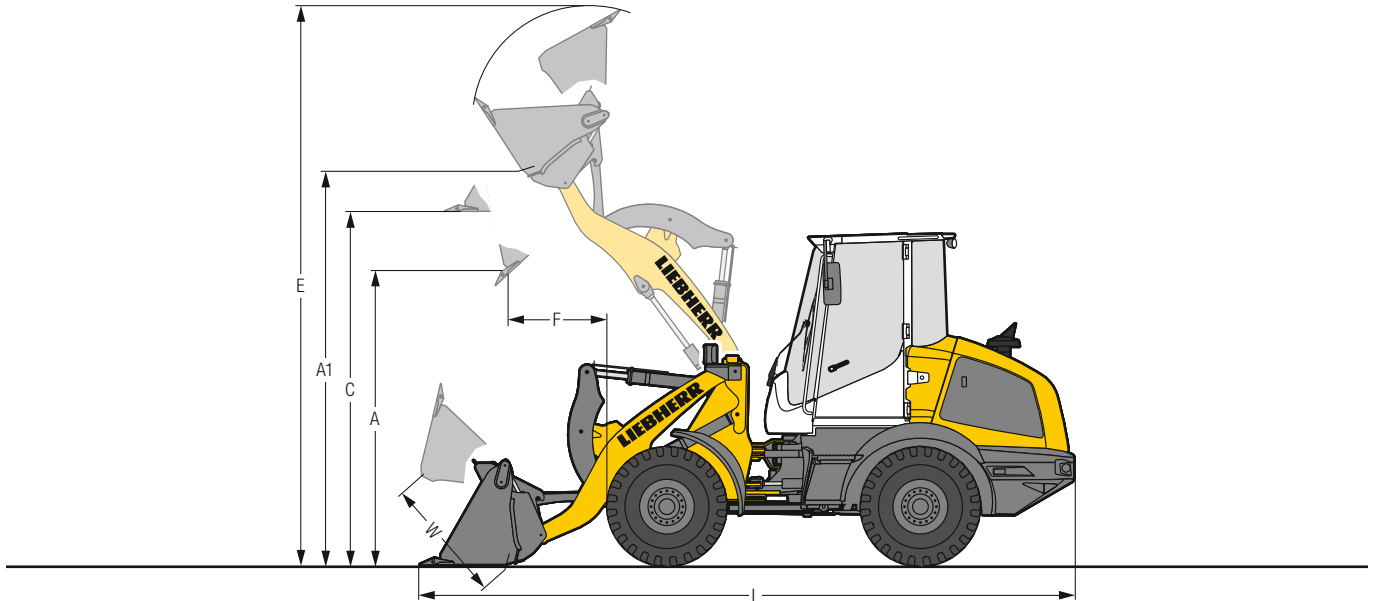

### 4 in 1 bucket

	L 507		L 509	
	STD	ZK-QH	STD	HL
Geometry	STD	ZK-QH	STD	HL
Cutting tools	T	T	T	T
Bucket capacity	0.8 m <sup>3</sup>	0.8 m <sup>3</sup>	1.1 m <sup>3</sup>	0.9 m <sup>3</sup>
Specific material density	1.8 t/m <sup>3</sup>	1.8 t/m <sup>3</sup>	1.8 t/m <sup>3</sup>	1.8 t/m <sup>3</sup>
Bucket width	2,100 mm	2,100 mm	2,200 mm	2,100 mm
A Dumping height at max. lift height and 42° discharge	2,545 mm	2,545 mm	2,630 mm	3,155 mm
A1 Max. dumping height with opened bucket	3,230 mm	3,230 mm	3,360 mm	3,800 mm
C Max. height of bucket bottom	2,950 mm	2,950 mm	3,080 mm	3,520 mm
E Max. operating height	4,720 mm	4,720 mm	4,930 mm	5,285 mm
F Reach at max. lift height and 42° discharge	880 mm	880 mm	990 mm	930 mm
L Overall length	5,585 mm	5,585 mm	5,905 mm	6,205 mm
W Max. bucket opening	960 mm	960 mm	960 mm	960 mm
Turning circle radius over outside bucket edge	3,975 mm	3,975 mm	4,220 mm	4,310 mm
Tipping load, straight*	3,550 kg	3,550 kg	4,270 kg	3,740 kg
Tipping load, fully articulated*	3,240 kg	3,240 kg	3,885 kg	3,400 kg
Operating weight*	5,835 kg	5,835 kg	6,660 kg	6,875 kg
Tyre size	365/70R18 L2		405/70R18 L2	

\* The figures shown include the above tyres, all lubricants, a full fuel tank, the ROPS/FOPS cab and the operator.  
Different tyres and optional equipment will change the operating weight and tipping load. (Tipping load, fully articulated according to ISO 14397-1)

- STD = Standard lift arm length
- HL = High Lift
- ZK-QH = Z-bar linkage incl. quick hitch
- T = Welded-on tooth holder with add-on teeth

# Attachment

## Fork carrier and fork

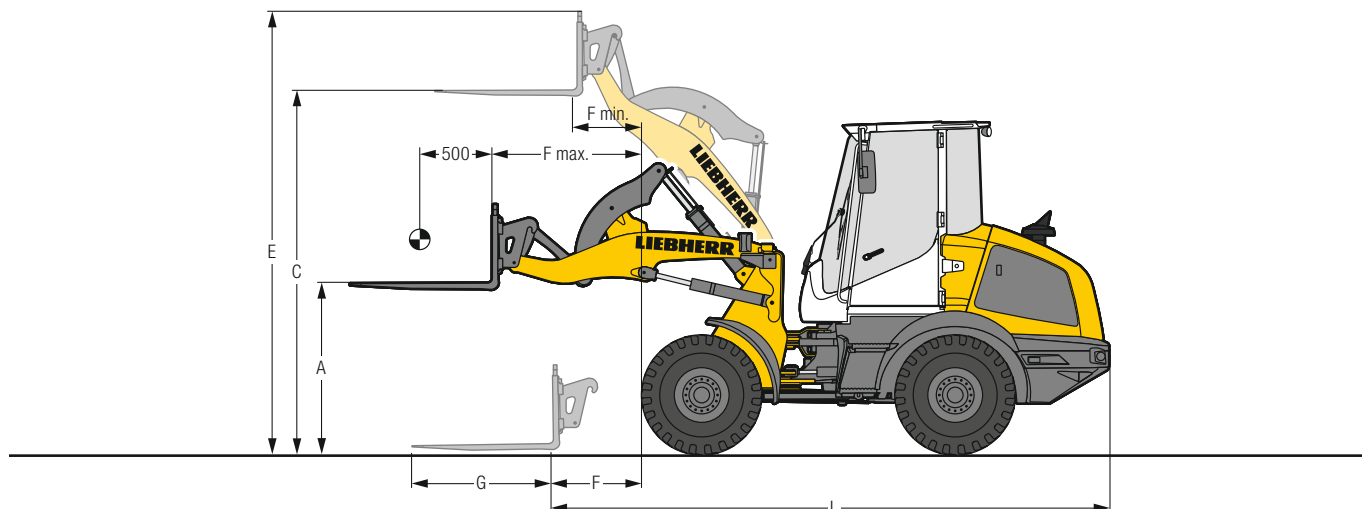

### FEM II fork carrier and fork

		L 507	STD	L 509	HL
Geometry		ZK-QH	ZK-QH	ZK-QH	ZK-QH
A	Lifting height at max. reach	mm	1,450	1,500	1,490
C	Max. lifting height	mm	3,045	3,175	3,615
E	Max. operating height	mm	3,715	3,840	4,280
F	Reach at loading position	mm	740	810	1,200
F max.	Max. reach	mm	1,235	1,330	1,640
F min.	Reach at max. lifting height	mm	525	570	500
G	Fork length	mm	1,200	1,200	1,200
L	Length - basic machine	mm	4,825	5,040	5,425
	Tipping load, straight*	kg	3,215	3,840	3,400
	Tipping load, fully articulated*	kg	2,930	3,500	3,090
	Recommended payload for uneven ground = 60% of tipping load, articulated <sup>3)</sup>	kg	1,820	2,100	1,850
	Recommended payload for smooth surfaces = 80% of tipping load, articulated <sup>3)</sup>	kg	2,300 <sup>1)</sup>	2,500 <sup>2)</sup>	2,470
	Operating weight*	kg	5,445	6,175	6,490
	Tyre size		365/70R18 L2	405/70R18 L2	

\* The figures shown include the above tyres, all lubricants, a full fuel tank, the ROPS/FOPS cab and the operator.  
Different tyres and optional equipment will change the operating weight and tipping load. (Tipping load, fully articulated according to ISO 14397-1)

<sup>1)</sup> Payload is limited by tilt cylinder - max. load capacity for the fork carrier FEM II 2,500 kg

<sup>2)</sup> Payload is limited by FEM II fork carrier and forks to 2,500 kg

<sup>3)</sup> According to EN 474-3

STD = Standard lift arm length

HL = High Lift

ZK-QH = Z-bar linkage incl. quick hitch

# Bucket selection

L 507 - L 509

## L 507

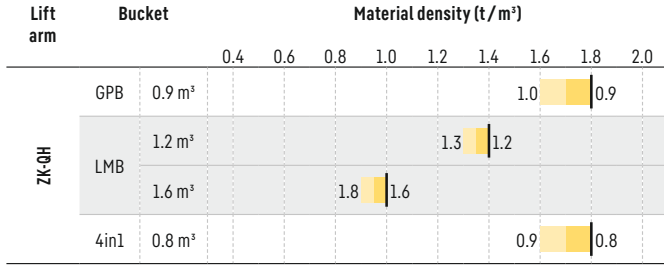

## L 509

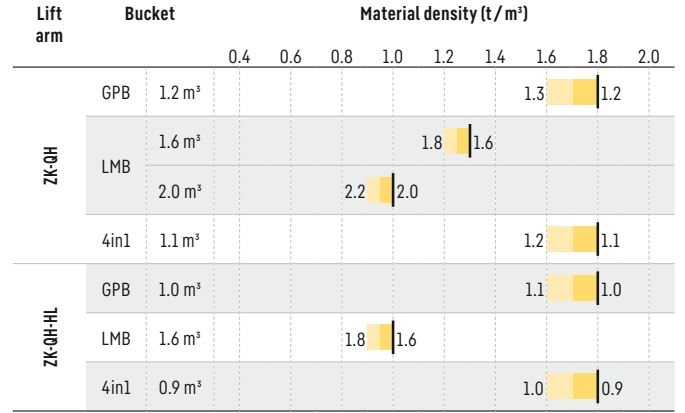

### Bucket filling factor

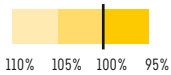

### Lift arm

<b>ZK-QH</b>	Z-bar linkage with quick hitch, standard lift arm length
<b>ZK-QH-HL</b>	Z-bar linkage with quick hitch, High Lift

### Bucket

<b>GPB</b>	General purpose bucket (Excavation bucket)
<b>LMB</b>	Light material bucket
<b>4in1</b>	4 in 1 bucket

### Bulk material densities and bucket filling factors

		t/m³	%			t/m³	%			t/m³	%
Gravel	moist	1.9	105	Earth	dry	1.3	115	Glass waste	broken	1.4	100
	dry	1.6	105		wet excavated	1.6	110		solid	1.0	100
	crushed stone	1.5	100	Topsoil		1.1	110	Compost	dry	0.8	105
Sand	dry	1.5	105	Basalt		1.95	100	wet	1.0	110	
	wet	1.9	110	Granite		1.8	95	Wood chips / Saw dust		0.5	110
Gravel and Sand	dry	1.7	105	Sandstone		1.6	100	Paper	shredded / loose	0.6	110
	wet	2.0	100	Slate		1.75	100	recovered paper / cardboard	1.0	110	
Sand / Clay		1.6	110	Bauxite		1.4	100	Coal	heavy material density	1.2	110
Clay	natural	1.6	110	Limestone		1.6	100	light material density	0.9	110	
	dry	1.4	110	Gypsum	broken	1.8	100	Waste	domestic waste	0.5	100
Clay / Gravel	dry	1.4	110	Coke		0.5	110	bulky waste	1.0	100	
	wet	1.6	100	Slag	broken	1.8	100				

# Tyres



## Tyre types

	Size and tread code		Change of operating weight kg	Width over tyres mm	Change in vertical dimensions* mm	Use
<b>L 507</b>						
Goodyear	405/70R20 Powerload	L2	111	1,960	47	Sand, Gravel, Asphalt (all ground conditions)
Goodyear	405/70R18 Powerload	L2	56	1,950	14	Sand, Gravel, Asphalt (all ground conditions)
Goodyear	365/80R20 Powerload	L2	60	1,910	46	Sand, Gravel, Asphalt (all ground conditions)
Goodyear	365/70R18 Powerload	L2	- 4	1,910	- 3	Sand, Gravel, Asphalt (all ground conditions)
Dunlop	15.5/55R18 SP PG7	L2	- 32	1,920	- 28	Sand, Gravel, Asphalt (all ground conditions)
Firestone	340/80R18 Duraforce UT	L3	21	1,900	15	Gravel, Asphalt, Industry (all ground conditions)
Firestone	405/70R18 Duraforce UT	L3	92	1,960	23	Gravel, Asphalt, Industry (all ground conditions)
Firestone	365/80R20 Duraforce UT	L3	80	1,920	53	Gravel, Asphalt, Industry (all ground conditions)
Firestone	400/70R20 Duraforce UT	L3	122	1,950	43	Gravel, Asphalt, Industry (all ground conditions)
Firestone	400/70R20 R8000 UT	L2	99	1,950	43	Earthworks, Green area (all ground conditions)
Michelin	400/70R20 BIBLOAD	L3	96	1,950	38	Gravel, Asphalt, Industry (firm ground conditions)
Michelin	400/70R20 XMCL	L2	112	1,960	44	Earthworks, Green area (all ground conditions)
Mitas	365/70R18 EM-01	L2	0	1,920	0	Gravel, Asphalt (all ground conditions)
Mitas	365/80R20 EM-01	L2	72	1,920	52	Gravel, Asphalt (all ground conditions)
Mitas	405/70R18 EM-01	L2	56	1,960	25	Gravel, Asphalt (all ground conditions)
Mitas	405/70R20 EM-01	L2	92	1,960	50	Gravel, Asphalt (all ground conditions)
Nokian	400/70R20 Hakkapeliitta TRI	L2	112	1,950	48	Winter tyres, Gravel, Asphalt (all ground conditions)
Trelleborg	400/70R20 TH400	L2	106	1,950	38	Earthworks, Green area (all ground conditions)
<b>L 509</b>						
Goodyear	405/70R20 Powerload	L2	55	2,090	22	Sand, Gravel, Asphalt (all ground conditions)
Goodyear	405/70R18 Powerload	L2	0	2,080	- 11	Sand, Gravel, Asphalt (all ground conditions)
Goodyear	365/80R20 Powerload	L2	4	2,040	21	Sand, Gravel, Asphalt (all ground conditions)
Dunlop	15.5/55R18 SP PG7	L2	- 88	2,050	- 53	Sand, Gravel, Asphalt (all ground conditions)
Firestone	365/80R20 Duraforce UT	L3	24	2,050	28	Gravel, Asphalt, Industry (all ground conditions)
Firestone	400/70R20 Duraforce UT	L3	66	2,080	18	Gravel, Asphalt, Industry (all ground conditions)
Firestone	405/70R18 Duraforce UT	L3	36	2,090	- 2	Gravel, Asphalt, Industry (all ground conditions)
Firestone	400/70R20 R8000 UT	L2	43	2,080	18	Earthworks, Green area (all ground conditions)
Michelin	400/70R20 BIBLOAD	L3	40	2,080	13	Gravel, Asphalt, Industry (firm ground conditions)
Michelin	400/70R20 XMCL	L2	56	2,090	19	Earthworks, Green area (all ground conditions)
Mitas	405/70R18 EM-01	L2	0	2,090	0	Gravel, Asphalt (all ground conditions)
Mitas	365/80R20 EM-01	L2	16	2,050	27	Gravel, Asphalt (all ground conditions)
Mitas	405/70R20 EM-01	L2	36	2,090	25	Gravel, Asphalt (all ground conditions)
Nokian	400/70R20 Hakkapeliitta TRI	L2	56	2,080	23	Winter tyres, Gravel, Asphalt (all ground conditions)
Trelleborg	400/70R20 TH400	L2	50	2,080	13	Earthworks, Green area (all ground conditions)

\* The stated values are theoretical and may deviate in practice.

Before operating the vehicle with tyre foam filling or tyre protection chains, please discuss this with the Liebherr-Werk Bischofshofen GmbH.

# Technical data

L 514 - L 518

## Diesel engine

	L 514	L 518
<b>Diesel engine</b>	4045HB551	4045HB551
Design	Water-cooled turbocharged in-series engine, intercooler	
Cylinder inline	4	4
Fuel injection process	Electronic Common Rail high-pressure injection	
Output to	kW/HP	76/103
ISO 9249 - SAE J1349	at RPM	2,000
Rated output to		
ISO 14396 / ECE-R.120	kW/HP	76/103
Nominal speed	at RPM	2,400
Max. torque to	Nm	420
ISO 14396	at RPM	1,400
Displacement	litres	4.5
Bore / Stroke	mm	106 / 127
<b>Stage V</b>		
Harmful emissions values	According to regulation (EU) 2016 / 1628	
Emission control	SCR technology and closed diesel particle filter system	
<b>Air cleaner system</b>	Dry type filter with main and safety element	
<b>Electrical system</b>		
Operating voltage	V	12
Battery	Ah	100
Alternator	V/A	12 / 120
Starter	V/kW	12 / 4.2

## Driveline

	L 514 Stereo L 518 Stereo	L 514 Speeder L 518 Speeder
<b>Hydrostatic driveline</b>		
Design	Continuous, swash plate type variable flow pump and variable axial piston motor in closed loop circuit	2-speed automated gearbox, swash plate type variable flow pump and variable axial piston motor in closed loop circuit
Filtration	Suction return line filter for closed circuit	
Control	By travel and inching pedal. The inching pedal makes it possible to control the tractive and thrust forces steplessly at full engine speed. The Liebherr control lever is used to control forward and reverse travel	
<b>Travel speed range</b>	Speed range 1: 0-8 km/h Speed range A1-2: 0-25 km/h Forward and reverse with tyre size 17.5R25 Speeds quoted apply with the tyres indicated as standard on loader model.	Speed range 1: 0-18 km/h Speed range A1-2: 0-40 km/h*

\* Configuration, tyres and mounting tools can influence the maximum speed.

## Brakes

	L 514 Stereo L 518 Stereo	L 514 Speeder L 518 Speeder
<b>Service brake</b>	Wear-free service brake due to hydrostatic driveline, applied to all four wheels and additional hydraulically activated drum brake	Wear-free service brake due to hydrostatic driveline, applied to all four wheels and additional dual-circuit brake system, drum brake and wet multi-disc brake located in the front axle
<b>Parking brake</b>	Negative brake system on the drum brake	Negative brake system in the front axle acting on the wet multi-disc brakes

The braking system meets the requirements of the ISO 3450.

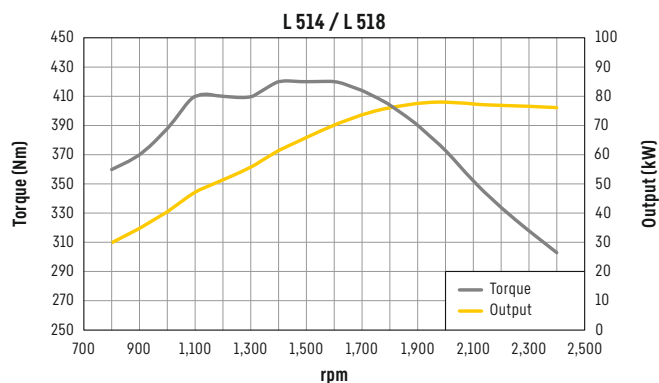

## Axles

	L 514	L 518
<b>Four-wheel drive</b>	Fixed	
<b>Front axle</b>	Fixed	
<b>Rear axle</b>	Axle pivot steering, with 5° oscillating angle to each side	
Height of obstacles which can be driven over	mm 600	600
<b>Differentials</b>	with all four wheels remaining in contact with the ground Automatic multi-disc limited slip differentials with 45% locking action in both axles	
<b>Reduction gear</b>	Planetary final drive in wheel hubs	
<b>Track width</b>	1,870 mm with tyres indicated as standard	

## Steering

<b>Design</b>	Stereo steering system, hydraulic servo power steering. Central oscillating frame articulation with damper element in combination with rear-axle pivot steering	
<b>Angle of articulation</b>	30° to each side	
<b>Angle of oscillation - centre-pivot steering</b>	5° to each side	
<b>Max. pressure</b>	bar	180

## Attachment hydraulics

	L 514	L 518
<b>Design</b>	Gear pump to supply the hydraulic and steering systems (via priority valve)	
<b>Cooling</b>	Hydraulic oil cooling using thermostatically controlled fan	
<b>Filtration</b>	Return line filter in the hydraulic reservoir	
<b>Control</b>	Liebherr control lever, hydraulically operated, with load-dependent delivery rate distribution, 1st and 2nd additional hydraulic function are electrically, proportional controlled	
<b>Lifting function</b>	Lifting, neutral, lowering Float position controlled by Liebherr control lever with detent, automatic hoist kick out optional	
<b>Tilt function</b>	Tilt back, neutral, dump Automatic bucket return to dig	
<b>Max. flow</b>	l/min. 115	115
<b>Max. pressure</b>	bar 240	280

## Attachment

	L 514	L 518
<b>Geometry</b>	Powerful Z-bar linkage with tilt cylinder, hydraulic quick hitch optional	
<b>Bearings</b>	Sealed	
<b>Cycle time at nominal load</b>	ZK	ZK
Lifting	s 6.9	6.9
Dumping	s 3.0	3.0
Lowering (empty)	s 4.9	4.9

## Operator's cab

<b>Design</b>	Elastic mounted, noise-proof cab ROPS roll over protection per EN ISO 3471 / EN 474-1 FOPS falling objects protection per EN ISO 3449 / EN 474-3, Cat. II Operator's door with 180° opening angle with rigid window, fold-out window on right with 12° gap opener or 180° opening, single-pane safety glass ESG, heated rear window ESG, all windows are tinted. Continuously adjustable steering column
<b>Liebherr operator's seat</b>	5 way adjustable, vibration-damped operator's seat "Standard" (mechanically sprung, adjustable to operator's weight), Liebherr control lever mounted into the operator's seat as standard
<b>Cab heating and ventilation</b>	Fresh / recirculated air mode, cab heating via cooling water, arrangement of the air nozzles ensures quick defrosting and defogging of the windows, electrically heated rear window
<b>Vibration emissions</b>	
Hand / arm vibrations	≤ 2.5 m/s <sup>2</sup> , according with ISO 5349-1:2001
Whole-body vibrations	≤ 0.5 m/s <sup>2</sup> , complies with technical report ISO/TR 25398:2006
Measuring inaccuracy	According with standard EN 12096:1997

## Sound level

	L 514	L 518
<b>Sound pressure level to ISO 6396</b>		
L <sub>PA</sub> (inside cab) dB(A)	70	70
<b>Sound power level to 2000/14/EC</b>		
L <sub>WA</sub> (surround noise) dB(A)	101	101

## Capacities

	L 514 Stereo	L 514 Speeder	L 518 Stereo	L 518 Speeder
<b>Fuel tank</b>	l 155	155	155	155
<b>DEF tank</b>	l 18	18	18	18
<b>Engine oil (inclusive filter change)</b>	l 14	14	14	14
<b>Travel gear / rear axle</b>	l 1	2	1	2
<b>Coolant</b>	l 21	21	21	21
<b>Front axle / differential</b>	l 7.5	7.5	7.5	7.5
<b>Rear axle / differential</b>	l 7.5	7.5	7.5	7.5
<b>Front axle / wheel hubs</b>	l 1.5	1.5	4	4
<b>Rear axle / wheel hubs</b>	l 1.5	1.5	4	4
<b>Hydraulic tank</b>	l 72	72	72	72
<b>Hydraulic system, total</b>	l 115	115	115	115

# Dimensions

## Z-bar linkage

L 514 - L 518

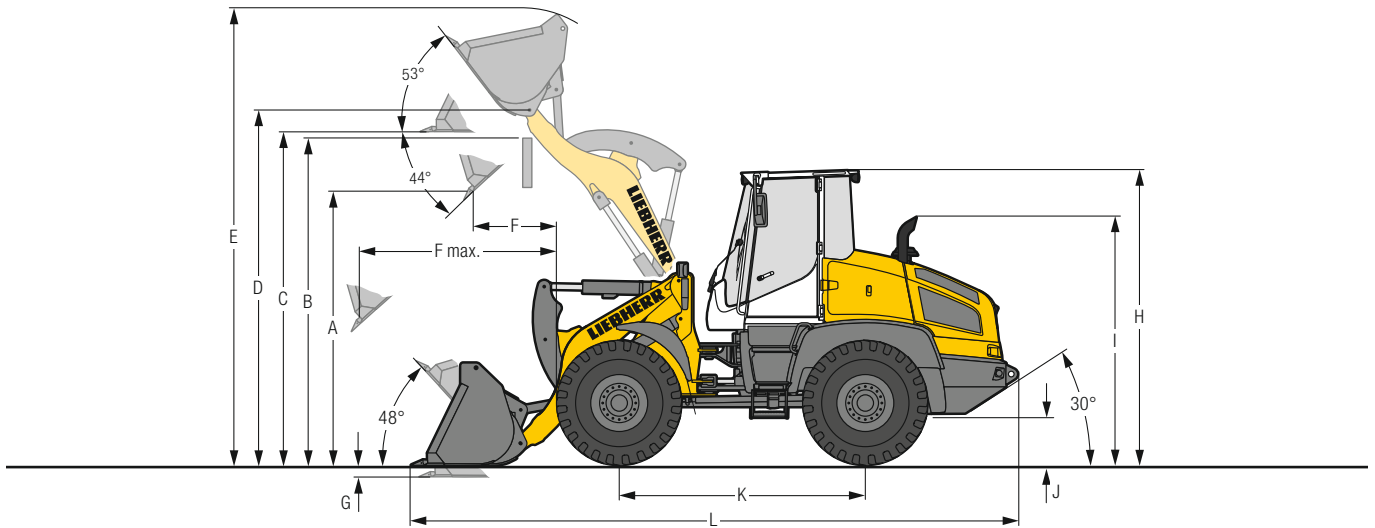

### Excavation bucket

	L 514			L 518		
	STD	HL	ZK-QH	STD	HL	ZK-QH
Geometry	ZK	ZK-QH	ZK-QH	ZK	ZK-QH	ZK-QH
Cutting tools	T	T	T	T	T	T
Lift arm length	2,400	2,400	2,645	2,400	2,400	2,645
Bucket capacity according to ISO 7546 **	1.5	1.4	1.3	1.7	1.5	1.4
Specific material density	1.8	1.8	1.6	1.8	1.8	1.6
Bucket width / Bucket weight	2,400 / 620	2,400 / 590	2,400 / 540	2,400 / 655	2,400 / 565	2,400 / 590
A Dumping height at max. lift height and 44° discharge	2,915	2,915	3,170	2,875	2,835	3,140
B Dump-over height	3,350	3,370	3,645	3,350	3,370	3,645
C Max. height of bucket bottom	3,490	3,500	3,785	3,485	3,480	3,780
D Max. height of bucket pivot point	3,720	3,720	4,010	3,720	3,720	4,010
E Max. operating height	4,735	4,795	5,020	4,770	4,805	5,085
F Reach at max. lift height and 44° discharge	820	785	860	865	905	860
F max. Max. reach at 44° discharge	1,640	1,630	1,915	1,680	1,725	1,935
G Digging depth	75	70	125	80	70	125
H Height above operator's cab	3,080	3,080	3,080	3,080	3,080	3,080
I Height above exhaust	2,575	2,575	2,575	2,575	2,575	2,575
J Ground clearance	430	430	430	430	430	430
K Wheelbase	2,600	2,600	2,600	2,600	2,600	2,600
L Overall length	6,400	6,360	6,750	6,445	6,500	6,775
Turning circle radius over tyres	4,200	4,200	4,200	4,200	4,200	4,200
Turning circle radius over outside bucket edge	4,510	4,450	4,675	4,560	4,565	4,725
Breakout force (SAE)	73	68	70	80	75	67
Tipping load, straight *	6,280	6,095	5,275	7,160	6,860	5,720
Tipping load, fully articulated *	5,750	5,575	4,825	6,550	6,280	5,230
Operating weight *	8,860	9,070	9,120	9,190	9,320	9,440
Tyre size	17.5R25 L3			17.5R25 L3		

\* The figures shown include the above tyres, all lubricants, a full fuel tank, the ROPS / FOPS cab and the operator.

Different tyres and optional equipment will change the operating weight and tipping load. (Tipping load, fully articulated according to ISO 14397-1)

\*\* Actual bucket capacity may be approx. 10% larger than the calculation according to ISO 7546 standard. The degree to which the bucket can be filled depends on the material - see page 30.

- STD = Standard lift arm length
- HL = High Lift
- ZK = Z-bar linkage
- ZK-QH = Z-bar linkage incl. quick hitch
- T = Welded-on tooth holder with add-on teeth

# Attachment

## Light material bucket

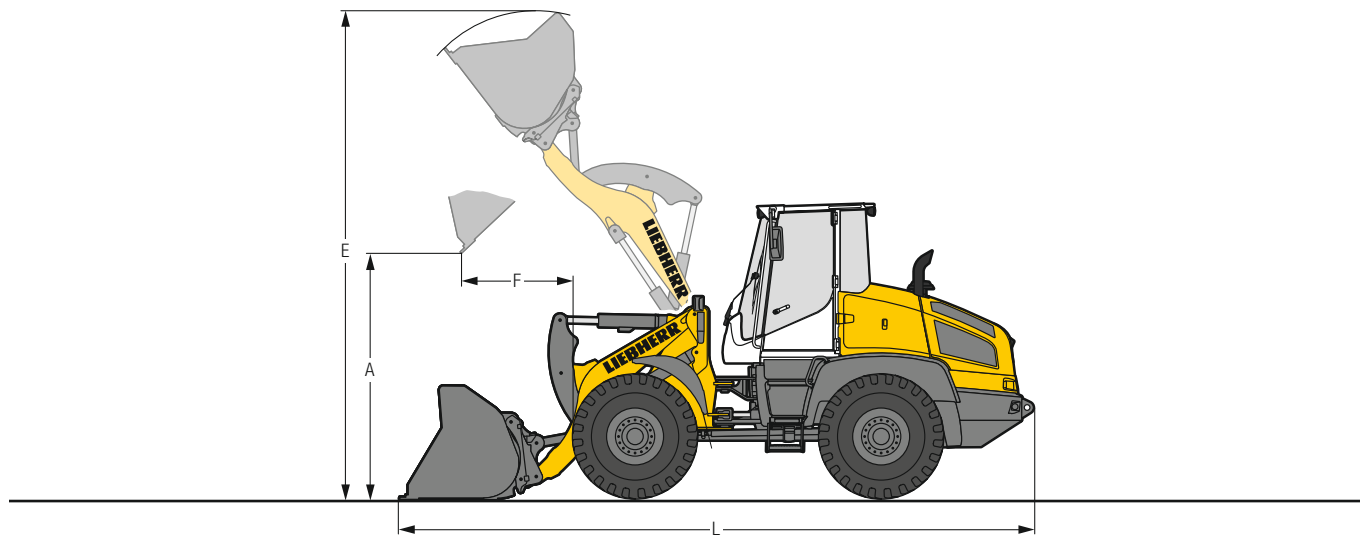

L 514 - L 518



### Heavy material density

		L 514		L 518	
		STD	HL	STD	HL
		ZK-QH	ZK-QH	ZK-QH	ZK-QH
Geometry		ZK-QH	ZK-QH	ZK-QH	ZK-QH
Cutting tools		BOCE	BOCE	BOCE	BOCE
Bucket capacity	m <sup>3</sup>	2.0	2.0	2.5	2.0
Specific material density	t/m <sup>3</sup>	1.3	1.0	1.1	1.2
Bucket width	mm	2,500	2,500	2,500	2,500
A Dumping height at max. lift height	mm	2,745	3,020	2,630	3,020
E Max. operating height	mm	4,970	5,265	5,105	5,265
F Reach at maximum lift height	mm	1,010	1,020	1,130	1,020
L Overall length	mm	6,540	6,865	6,730	6,865
Tipping load, straight*	kg	5,680	4,955	6,395	5,370
Tipping load, fully articulated*	kg	5,200	4,535	5,850	4,915
Operating weight*	kg	9,250	9,350	9,610	9,625
Tyre size		17.5R25 L3		17.5R25 L3	

\* The figures shown include the above tyres, all lubricants, a full fuel tank, the ROPS / FOPS cab and the operator.

Different tyres and optional equipment will change the operating weight and tipping load. (Tipping load, fully articulated according to ISO 14397-1)

For wheel loaders with large light material buckets and high-dump buckets or log grapples, we supply visual aids such as mirrors or cameras for front area monitoring that meet the requirements of the ISO 5006:2017 field of vision test.

STD = Standard lift arm length

HL = High Lift

ZK-QH = Z-bar linkage incl. quick hitch

BOCE = Bolt-on cutting edge

# Attachment

## High-dump bucket

L 514 - L 518

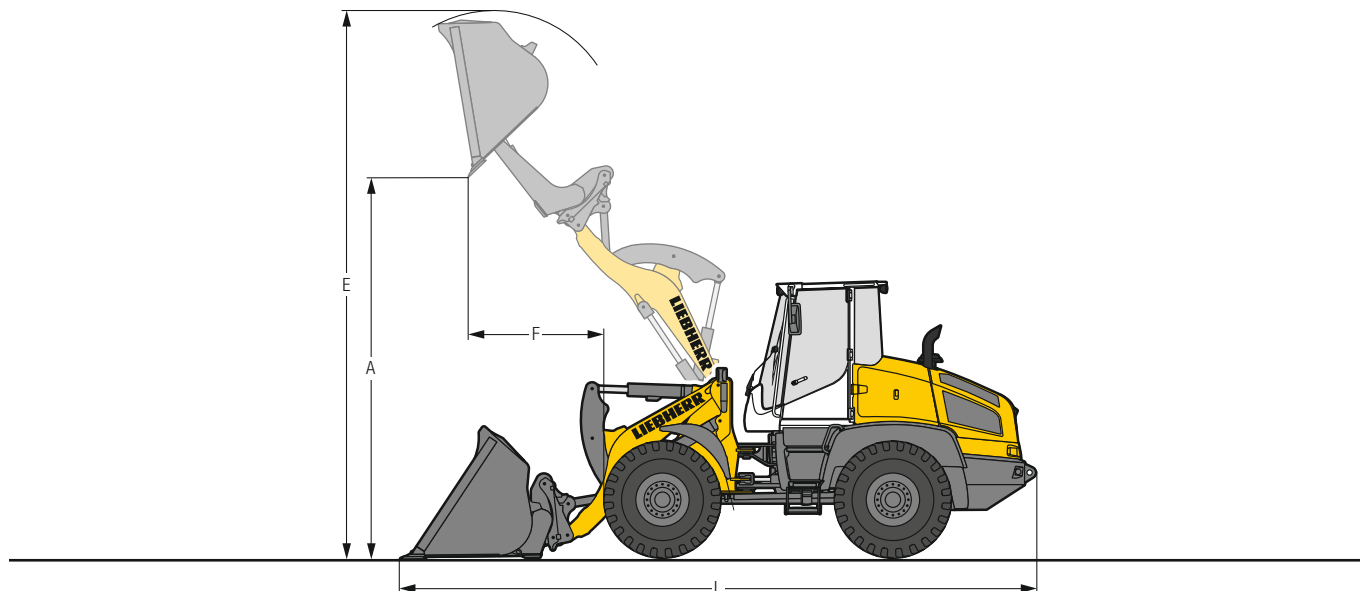

### Heavy material density

	L 514		L 518	
	STD	HL	STD	HL
Geometry	ZK-QH	ZK-QH	ZK-QH	ZK-QH
Cutting tools	BOCE	BOCE	BOCE	BOCE
Bucket capacity	m <sup>3</sup> 2.2	1.8	2.5	2.0
Specific material density	t/m <sup>3</sup> 1.0	1.0	1.0	1.0
Bucket width	mm 2,500	2,200	2,500	2,490
A Dumping height at max. lift height	mm 4,200	4,580	4,200	4,560
E Max. operating height	mm 5,760	6,060	5,850	5,970
F Reach at maximum lift height	mm 1,400	1,470	1,380	1,490
L Overall length	mm 6,965	7,300	6,965	7,240
Tipping load, straight*	kg 4,655	4,150	5,600	4,550
Tipping load, fully articulated*	kg 4,260	3,800	5,120	4,160
Operating weight*	kg 9,985	9,870	10,280	10,050
Tyre size	17.5R25 L3		17.5R25 L3	



### Light material density

	L 514		L 518	
	STD	HL	STD	HL
Geometry	ZK-QH	ZK-QH	ZK-QH	ZK-QH
Cutting tools	BOCE	BOCE	BOCE	BOCE
Bucket capacity	m <sup>3</sup> 3.5	3.0	4.0	3.5
Specific material density	t/m <sup>3</sup> 0.5	0.5	0.5	0.5
Bucket width	mm 2,700	2,700	2,700	2,700
A Dumping height at max. lift height	mm 4,295	4,410	4,275	4,615
E Max. operating height	mm 6,045	6,115	6,200	6,355
F Reach at maximum lift height	mm 1,540	1,400	1,525	1,560
L Overall length	mm 7,170	7,235	7,170	7,500
Tipping load, straight*	kg 4,455	4,125	5,495	4,230
Tipping load, fully articulated*	kg 4,075	3,770	5,025	3,870
Operating weight*	kg 9,935	9,930	10,445	10,305
Tyre size	17.5R25 L3		17.5R25 L3	

\* The figures shown include the above tyres, all lubricants, a full fuel tank, the ROPS/FOPS cab and the operator.

Different tyres and optional equipment will change the operating weight and tipping load. (Tipping load, fully articulated according to ISO 14397-1)

For wheel loaders with large light material buckets and high-dump buckets or log grapples, we supply visual aids such as mirrors or cameras for front area monitoring that meet the requirements of the ISO 5006:2017 field of vision test.

STD = Standard Hubgerüst-Länge

HL = High Lift

ZK-SW = Z-Kinematik inkl. Schnellwechseinrichtung

USM = Unterschraubmesser

# Attachment

## Fork carrier and fork

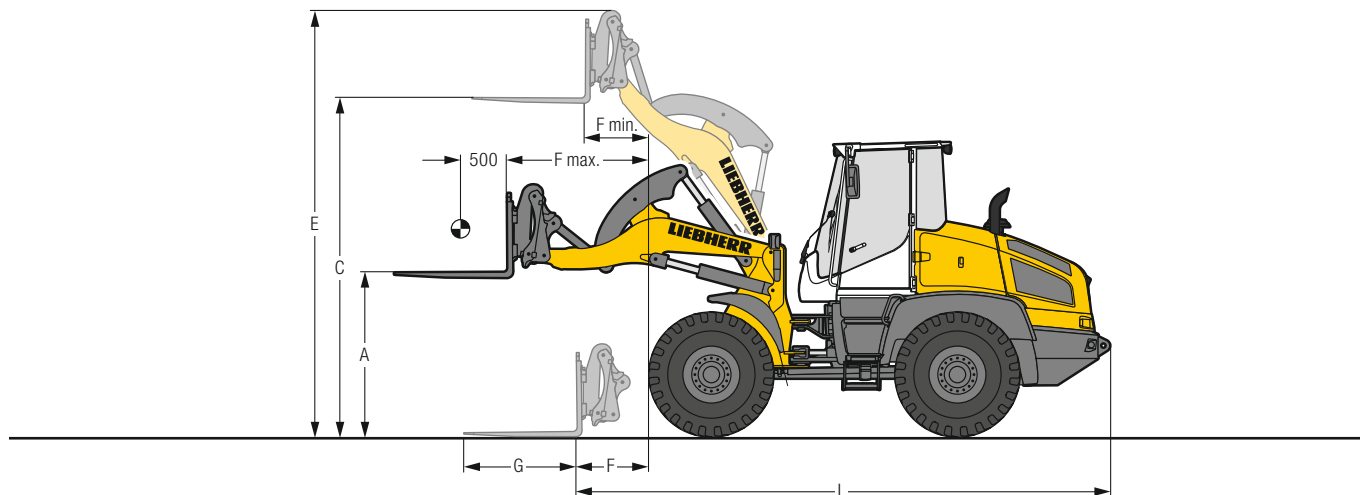

L 514 - L 518

### FEM III fork carrier and fork

	L 514		L 518	
	STD	HL	STD	HL
<b>Geometry</b>	ZK-QH	ZK-QH	ZK-QH	ZK-QH
A Lifting height at max. reach	mm 1,745	1,725	1,745	1,725
C Max. lifting height	mm 3,575	3,865	3,575	3,865
E Max. operating height	mm 4,495	4,785	4,495	4,785
F Reach at loading position	mm 765	1,095	765	1,095
F max. Max. reach	mm 1,460	1,705	1,460	1,705
F min. Reach at max. lifting height	mm 615	645	615	645
G Fork length	mm 1,200	1,200	1,200	1,200
L Length - basic machine	mm 5,640	5,970	5,640	5,970
Tipping load, straight*	kg 4,500	3,980	5,145	4,550
Tipping load, fully articulated*	kg 4,120	3,640	4,700	4,160
Recommended payload for uneven ground = 60% of tipping load, articulated <sup>1)</sup>	kg 2,475	2,185	2,825	2,495
Recommended payload for smooth surfaces = 80% of tipping load, articulated <sup>1)</sup>	kg 3,300	2,900	3,765	3,330
Operating weight*	kg 8,930	9,030	9,200	9,300
Tyre size	17.5R25 L3		17.5R25 L3	

\* The figures shown include the above tyres, all lubricants, a full fuel tank, the ROPS / FOPS cab and the operator.  
Different tyres and optional equipment will change the operating weight and tipping load. (Tipping load, fully articulated according to ISO 14397-1)

<sup>1)</sup> According to EN 474-3

STD = Standard lift arm length  
HL = High Lift  
ZK-QH = Z-bar linkage incl. quick hitch

# Bucket selection

L 514 – L 518

## L 514

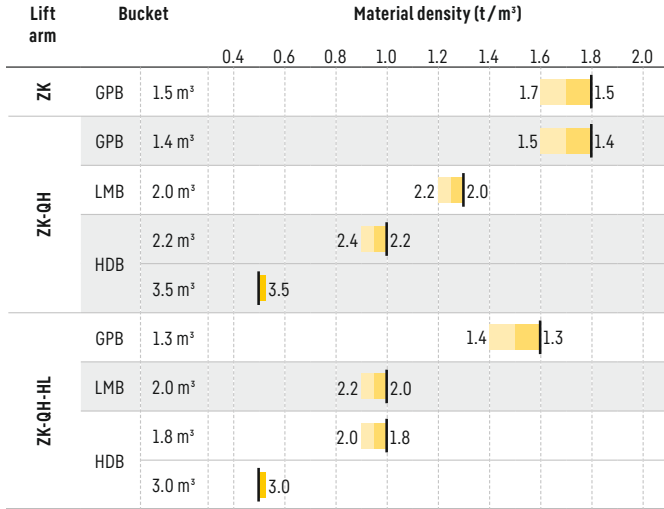

## L 518

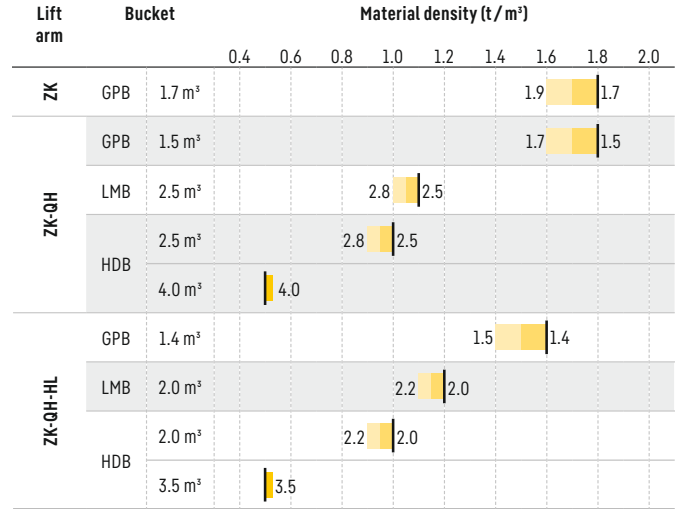

## Bucket filling factor

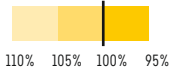

## Lift arm

<b>ZK</b>	Z-bar linkage, standard lift arm length
<b>ZK-QH</b>	Z-bar linkage with quick hitch, standard lift arm length
<b>ZK-QH-HL</b>	Z-bar linkage with quick hitch, High Lift

## Bucket

<b>GPB</b>	General purpose bucket (Excavation bucket)
<b>LMB</b>	Light material bucket
<b>HDB</b>	High-dump bucket

For wheel loaders with large light material buckets and high-dump buckets or log grapples, we supply visual aids such as mirrors or cameras for front area monitoring that meet the requirements of the ISO 5006:2017 field of vision test.

## Bulk material densities and bucket filling factors

		t/m³	%			t/m³	%			t/m³	%
Gravel	moist	1.9	105	Earth	dry	1.3	115	Glass waste	broken	1.4	100
	dry	1.6	105		wet excavated	1.6	110		solid	1.0	100
	crushed stone	1.5	100	Topsoil		1.1	110	Compost	dry	0.8	105
Sand	dry	1.5	105	Basalt		1.95	100	wet	1.0	110	
	wet	1.9	110	Granite		1.8	95	Wood chips / Saw dust		0.5	110
Gravel and Sand	dry	1.7	105	Sandstone		1.6	100	Paper	shredded / loose	0.6	110
	wet	2.0	100	Slate		1.75	100	recovered paper / cardboard		1.0	110
Sand / Clay		1.6	110	Bauxite		1.4	100	Coal	heavy material density	1.2	110
Clay	natural	1.6	110	Limestone		1.6	100	light material density		0.9	110
	dry	1.4	110	Gypsum	broken	1.8	100	Waste	domestic waste	0.5	100
Clay / Gravel	dry	1.4	110	Coke		0.5	110	bulky waste		1.0	100
	wet	1.6	100	Slag	broken	1.8	100				

# Tyres



## Tyre types

	Size and tread code		Change of operating weight kg	Width over tyres mm	Change in vertical dimensions* mm	Use
<b>L 514</b>						
Bridgestone	550/65R25 VTS	L3	420	2,470	11	Gravel (all ground conditions)
Goodyear	17.5R25 RL-4K	L4	588	2,370	41	Gravel, Industry, Stone (firm ground conditions)
Goodyear	17.5R25 RL-5K	L5	712	2,370	41	Stone, Scrap, Recycling (firm ground conditions)
Michelin	17.5R25 XLD D2A	L5	396	2,370	36	Stone, Mining spoil (firm ground conditions)
<b>L 518</b>						
Bridgestone	550/65R25 VTS	L3	434	2,470	11	Gravel (all ground conditions)
Goodyear	17.5R25 RL-4K	L4	602	2,370	41	Gravel, Industry, Stone (firm ground conditions)
Goodyear	17.5R25 RL-5K	L5	726	2,370	41	Stone, Scrap, Recycling (firm ground conditions)
Michelin	17.5R25 XLD D2A	L5	410	2,370	36	Stone, Mining spoil (firm ground conditions)
<b>L 514 / L 518</b>						
Bridgestone	17.5R25 VJT	L3	134	2,360	17	Bulk material (firm ground conditions)
Bridgestone	17.5R25 VUT	L2	- 4	2,360	3	Gravel, Earthworks, Clay (all ground conditions)
Goodyear	17.5R25 TL-3A+	L3	276	2,380	22	Sand, Gravel, Earthworks, Clay (all ground conditions)
Michelin	17.5R25 XHA	L3	43	2,370	- 1	Sand, Gravel (all ground conditions)
Michelin	17.5R25 XHA2	L3	0	2,380	0	Sand, Gravel (all ground conditions)
Nokian	17.5R25 Hakkapeliitta Loader	L2	40	2,370	10	Winter tyres, Gravel, Asphalt (all ground conditions)

\* The stated values are theoretical and may deviate in practice.

Before operating the vehicle with tyre foam filling or tyre protection chains, please discuss this with the Liebherr-Werk Bischofshofen GmbH.

# Tipping load



## What is tipping load?

Load at centre of gravity of working equipment, so that the wheel loader just begins to tip over the front axle. This is the most unfavourable static-load position for the wheel loader. Lifting arms horizontal, wheel loader fully articulated at centre pivot.

## Pay load.

The pay load must not exceed 50% of the tipping load when articulated. This is equivalent to a static stability-margin factor of 2.0.

## Bucket capacity.

The bucket volume is determined from the pay load.

$$\text{Pay load} = \frac{\text{Tipping load, articulated}}{2}$$

$$\text{Bucket capacity} = \frac{\text{Pay load (t)}}{\text{Specific bulk weight of material (t/m}^3\text{)}}$$

# The Liebherr wheel loaders

## Wheel loader



		L 504 Compact	L 506 Compact	L 507 Stereo	L 508 Compact	L 509 Stereo	L 514 Stereo
Tipping load	kg	3.000	3.500	3.750	3.900	4.430	5.750
Bucket capacity	m <sup>3</sup>	0,7	0,8	0,9	1,0	1,2	1,5
Operating weight	kg	4.600	4.970	5.550	5.700	6.390	8.860
Engine output	kW / HP	34 / 46	47,5 / 64	50 / 68	47,5 / 64	54 / 73	76 / 103

## Wheel loader



		L 518 Stereo	L 526	L 538	L 546	L 550 XPower
Tipping load	kg	6,550	8,730	9,650	11,010	12,500
Bucket capacity	m <sup>3</sup>	1,7	2,2	2,6	3,0	3,4
Operating weight	kg	9,190	13,170	14,520	15,410	18,550
Engine output	kW / HP	76 / 103	116 / 158	129 / 175	138 / 188	163 / 222

## Wheel loader



		L 556 XPower	L 566 XPower	L 576 XPower	L 580 XPower	L 586 XPower
Tipping load	kg	13,750	15,900	17,600	19,200	21,600
Bucket capacity	m <sup>3</sup>	3,7	4,2	4,7	5,2	6,0
Operating weight	kg	19,600	23,900	25,700	27,650	32,600
Engine output	kW / HP	183 / 249	203 / 276	218 / 296	233 / 317	263 / 358

02.22

# Equipment

 <b>Basic wheel loader</b>	L 507	L 509	L 514	L 518
Air pre-cleaner	+	+	+	+
Automatic central lubrication system	+	+	+	+
Auxiliary heater (Additional heating with engine preheating)	+	+	+	+
Battery main switch (lockable)	●	●	●	●
Combined inching-braking system	●	●	●	●
Complete drive shaft protection	-	-	+	+
Connection for electrical equipment 7-pole	+	+	+	+
Cooling water pre-heating 220V	+	+	+	+
Crash protection, rear	-	-	+	+
DEF tank	-	-	●	●
Diesel particle filter	●	●	-	-
Fluff trap for radiator	-	-	+	+
Fuel pre-filter	●	●	●	●
Fuel pre-filter with pre-heating	-	-	+	+
Guard for headlights	+	+	+	+
Large-mesh radiator	-	-	+	+
Liebherr biodegradable hydraulic oil	+	+	+	+
Load lashing lugs	●	●	●	●
Lockable doors and engine hood	●	●	●	●
Multi-disc limited slip differentials in both axles	●	●	●	●
Parking brake	●	●	●	●
Power socket rear (13-pole, 12V)	+	+	+	+
Pre-heat system for cold starting	●	●	●	●
Rear license panel light	+	+	+	+
Reversible fan drive	+	+	+	+
Ride control	+	+	+	+
SCR technology incl. diesel particle filter	-	-	●	●
Special paint	+	+	+	+
Speed limitation 20 km/h as a factory preset	●	●	+	+
Speed limitation adjustable on key	+	+	+	+
Speeder version	+	+	+	+
Tool kit	●	●	●	●
Towing hitch	●	●	●	●
Tractive force adjustment	+	+	●	●

 <b>Equipment</b>	L 507	L 509	L 514	L 518
1st and 2nd electro-hydraulic, proportional additional function	+	+	+	+
1st electro-hydraulic, proportional additional function	+	+	+	+
Automatic bucket return	+	+	●	●
Automatic hoist kick-out	+	+	+	+
Control lever lock	+	+	+	+
Float position	●	●	●	●
Fork carrier and pallet forks	+	+	+	+
High-dump bucket	+	+	+	+
High-Flow hydraulic	+	+	-	-
Hydraulic connections rear	+	+	+	+
Hydraulic quick hitch	●	●	+	+
Hydraulic quick hitch Solidlink	+	+	-	-
Lift arm Z-bar linkage	●	●	●	●
Lift arm Z-bar linkage High Lift	-	+	+	+
Light material bucket	+	+	+	+
Load holding valves	+	+	+	+
Loading buckets incl. a range of cutting tools	+	+	+	+
Preparation for hydraulic quick hitch Solidlink (quick hitch without Solidlink block)	+	+	-	-
Telescopic wheel loader (Further information can be found in the brochure "L 509 Tele")	-	+	-	-
Tilt cylinder protection	+	+	+	+
Weighing device	-	-	+	+
Working hydraulics lockout	●	●	●	●

● = Standard  
 += Option  
 -= not available

# Equipment

 Operator's cab	L 507	L 509	L 514	L 518
3 way continuously adjustable steering column (height-adjustable, tilting, folding)	+	+	+	+
Adaptive working lighting	-	-	+	+
Air conditioning system	+	+	+	+
Amber beacon LED	+	+	+	+
Clothes hook	●	●	●	●
Comfort Grammer operator's seat with longitudinal absorption, seat heating and 2-point seatbelt	+	+	+	+
Cup holder	●	●	●	●
Display with tilting and height adjustment function	●	●	●	●
Electronical theft protection with code	+	+	+	+
Electronical theft protection with key	+	+	+	+
Emergency exit	●	●	●	●
Exterior mirror, tiltable	●	●	●	●
Exterior mirror, tiltable and heatable	+	+	+	+
Fire extinguisher in cab 2 kg	+	+	+	+
First aid kit	+	+	+	+
Floor mat	●	●	●	●
Fold-out window right 180°	●	●	●	●
Headlights front, double design, LED	+	+	+	+
Headlights front, single design, halogen	●	●	●	●
Headlights front, single design, LED	+	+	+	+
Headlights rear, double design, LED	+	+	+	+
Headlights rear, single design, halogen/LED	+	+	+	+
Hot-water heater with defroster and recirculated air mode	●	●	●	●
Inching device hand operated	+	+	+	+
Interior rear-view mirror	●	●	●	●
Liebherr Connect				
MyLiebherr Maintenance	+	+	+	+
MyLiebherr Performance	+	+	+	+
MyLiebherr Portal*	●	●	●	●
Liebherr control lever moving with operator's seat (incl. travel direction)	●	●	●	●
Liebherr control lever with mini-joystick for 1st and 2nd hydraulic, proportional additional function moving with operator's seat	+	+	+	+
Operating hour meter (integrated in display unit)	●	●	●	●

 Operator's cab	L 507	L 509	L 514	L 518
Particle filter F5	●	●	●	●
Power socket 12V	●	●	●	●
Preparation for radio installation	+	+	+	+
Radio Liebherr "Comfort" (DAB+ / USB / AUX / BLUETOOTH / handsfree set)	+	+	+	+
Radio Liebherr "Standard" (USB / AUX)	+	●	●	●
Rear window heated electrically	+	+	+	+
Sliding window left	+	+	+	+
Soundproof ROPS / FOPS cab	●	●	●	●
Standard Grammer operator's seat with mechanical absorption and 2-point seatbelt	●	●	●	●
Steering column fixed	●	●	-	-
Steering column folding	+	+	●	●
Storage box	●	●	●	●
Storage compartment	●	●	●	●
Sunblind front / rear	+	+	+	+
Wide angle mirror	+	+	+	+
Windscreen guard	+	+	+	+
Wipe system front / rear	●	●	●	●

 Safety	L 507	L 509	L 514	L 518
Active personnel detection at the rear	-	-	+	+
Back-up alarm acoustical / visual	+	+	+	+
Country-specific versions	+	+	+	+
Rear space monitoring with camera (integrated in display unit)	+	+	+	+

- = Standard
- + = Option
- = not available
- \* = activation required free of charge

Here you can download our wheel loader brochures:



Liebherr-Werk Bischofshofen GmbH

Postfach 49 · 5500 Bischofshofen, Austria · Phone +43 50809-10

info.lbh@liebherr.com · www.liebherr.com · www.facebook.com/LiebherrConstruction