

L 504 – L 508 Compact

LIEBHERR

Wheel loaders

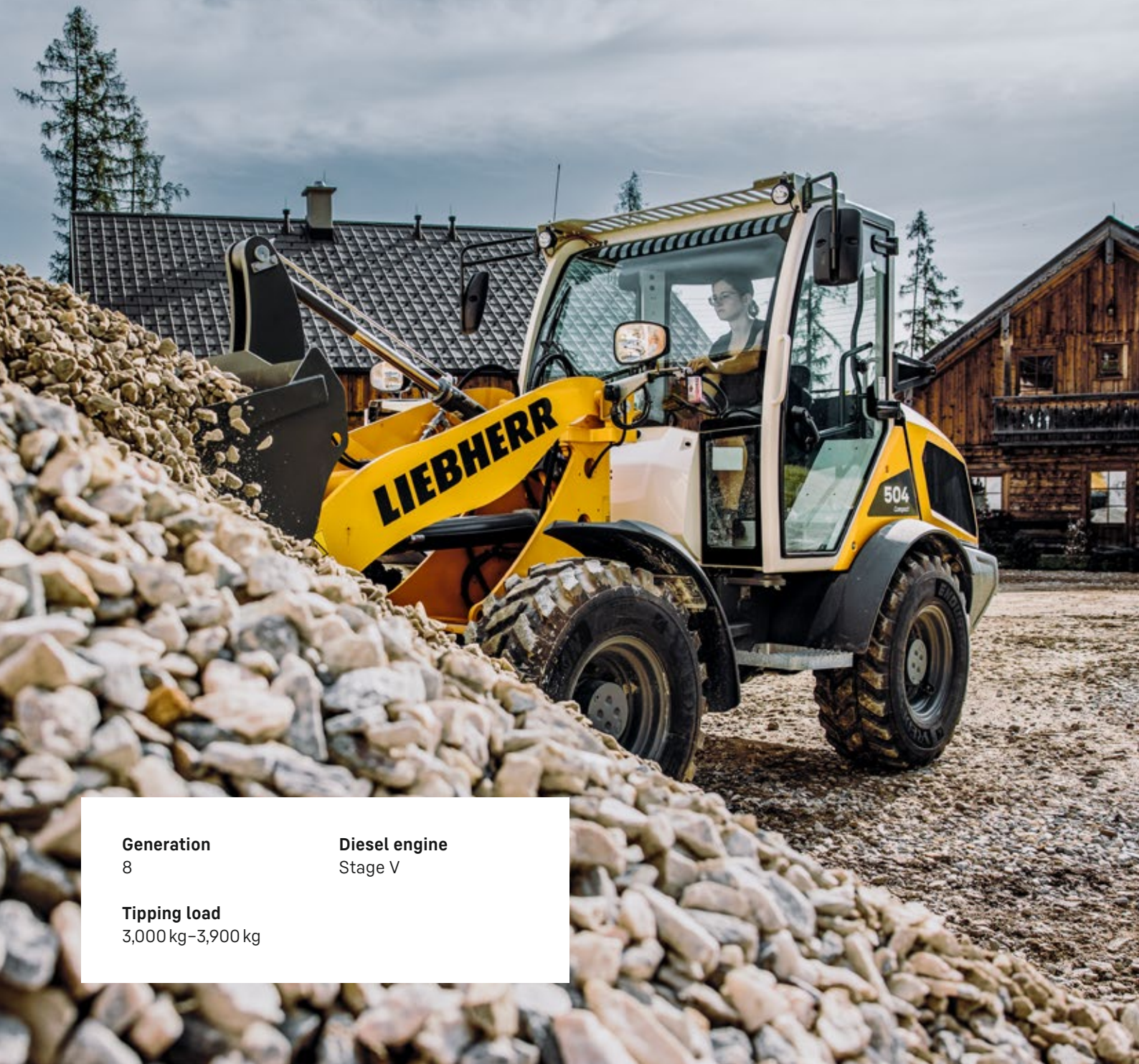

Generation
8

Diesel engine
Stage V

Tipping load
3,000 kg–3,900 kg

Performance

The flexible all-rounder –
a machine for every application

Economy

Efficient and resource-saving –
low costs with a high handling capacity

Reliability

Your new right-hand man –
proven quality, durable machines

Comfort

Compact engineering skill –
when technology combines comfort and safety

Maintainability

Simple and quick maintenance –
means time and cost savings for you





L 504

Tipping load, articulated
3,000 kg
Bucket capacity
0.7 m³
Operating weight
4,600 kg
Engine output
34 kW / 46 HP

L 506

Tipping load, articulated
3,500 kg
Bucket capacity
0.8 m³
Operating weight
4,970 kg
Engine output
47.5 kW / 64 HP

L 508

Tipping load, articulated
3,900 kg
Bucket capacity
1.0 m³
Operating weight
5,700 kg
Engine output
47.5 kW / 64 HP

Performance



The flexible all-rounder – a machine for every application

The compact loaders deliver performance, safety, and operational flexibility. The powerful lift arms significantly increase the compact loaders' performance and open up opportunities for new applications.



Versatile

- Ideal machine for applications of every kind, such as road construction, municipal services and construction sites
- A wide range of attachments increase versatility and make the compact loader a high performance and profitable all-rounder
- The standard hydraulic quick coupler system enables efficient attachment changes



High-performance lift arms

- Z-bar kinematics for higher productivity in all applications
- Optimal holding forces in the upper lifting range enable full utilization of the payload
- Secure load guidance in fork mode ensures accurate and precise working
- NEW: High-lift lift arms for L 506 (+ 150 mm) and L 508 (+215 mm)



Compact and stable

- Compact design results in a very low centre of gravity, making high payloads possible. This also enables maximum stability and resistance to tipping over
- Adjustments to the width and height of the L 508 results in an excellent view of the attachment as well as great stability, especially in raised lift arm positions

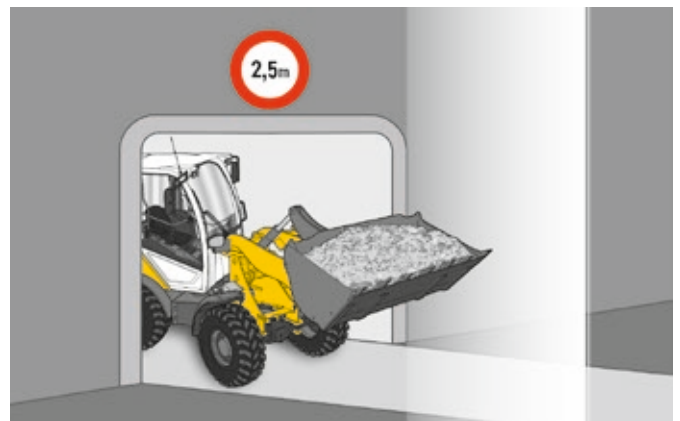

Compact machine design: a major advantage

- Low machine height of less than 2.5 metres (L 504 and L 506) facilitates fast and straightforward transportation
- Efficient and flexible use – low entrances and clearance heights are no obstacles

Economy



Efficient and resource-saving – low costs with a high handling capacity

Safe, practical, compact, and unbeatable value for the money – this is what sets the smallest Liebherr wheel loader series apart. The agile machines have impressive levels of operational efficiency and cost-effectiveness on all construction sites, in municipal services, or in road construction.



Maximum productivity

- Powerful hydrostatic Liebherr travel drive enables smooth acceleration without noticeable gear changes and without loss of tractive force
- Automatic limited slip differential provides outstanding traction, even on difficult terrain.
- This ensures maximum operational efficiency at outstanding value for the money



Faster and more cost-effective

- Jobs can be completed even faster with the new Speeder version (30 km/h) of the L 506 and L 508
- Additional 8 kilowatts of engine output in the Speeder version noticeably increases productivity
- This means work can be performed in a more direct and cost-efficient manner



Less downtime and lower operating costs

- Reduction in fuel consumption and CO₂ emissions due to an enhanced engine design with improved combustion
- A 30% increase in fuel tank volume means more time between refuelling and less unproductive downtime
- No diesel exhaust fluid or AdBlue required



Solidlink (optional)

- Hydraulic quick coupler with integrated automatic hydraulic coupling system
- Hydraulic attachments changed within seconds direct from the cab
- Change is fully automatic, safe, and with no fluid leakage
- Time saving due to convenience results in higher productivity and saves time and costs

Reliability



Your new right-hand man – proven quality, durable machines

Decades of experience in the development and production of wheel loaders has flowed into the new Liebherr compact loaders. Engineers started with customer needs and implemented these in the development process. The result is the safest and most practical machine in this segment, which, thanks to clever technology and well-matched components, delivers impressive quality and reliability.



High performance and durable components

- Decades of experience in the development, design and production of components is reflected in their robustness and durability
- Components are ideally matched to one another for maximum performance
- High Liebherr quality standards ensure reliability, even in the toughest operating conditions



Working without interruption

- Diesel oxidation catalysts (DOC) and diesel particulate filters (DPF) are installed for exhaust gas treatment, reducing emissions
- Uninterrupted work thanks to passive and active particle filter regeneration during operation
- Long intervals between regenerations increase productivity, save fuel, and reduce operating costs



Reliable Liebherr drive concept

- Proven hydrostatic Liebherr travel drive is extremely robust and powerful, and ensures a long service life for the machine
- Water-cooled diesel engine ensures constant cooling performance – especially on ascents or at high temperatures



Optimal cooling performance

- Radiator is positioned in the cleanest place on the wheel loader
- Cooling air is drawn in at the side behind the cab and flows through the entire engine compartment
- High machine availability due to lower radiator contamination

Comfort



Compact engineering skill – when technology combines comfort and safety

Get in the comfort zone – get in the new Liebherr compact loader cab. The new cab design is optimally tailored to everyday requirements in wheel loader operation. The spacious and ergonomically-designed operator's cab provides the perfect conditions for comfortable and productive working and can be individually adjusted to the operator.



Modern cab design for greater productivity

- Modern ergonomic cab design enables focused working with less fatigue
- Displays, control elements and operator's seat are ideally aligned with one another to form an ergonomic unit
- For the operator, the individual adjustment options on the operator's seat and the steering wheel create a pleasant working atmosphere with plenty of legroom
- Numerous storage compartments provide lots of space throughout the cab



Everything in view – for safe working

- Outstanding all-round visibility thanks to the generous amount of glass in the cab, which extends down partially to the footwell
- The tapered design of the lift arms offers an outstanding all-round view of the attachment and the operating area
- A compact machine design with an engine bonnet designed to optimise visibility provides an ideal view to the rear
- A reversing camera including independent display can be integrated into the cab as an option



Precise and responsive – the Liebherr control lever

- All of the machine's working and driving functions can be controlled precisely and safely using the Liebherr control lever
- Hydraulic attachments are controlled proportionally using the Liebherr control lever with mini-joystick
- 3-way adjustable steering column (optional) as well as an improved layout of the control elements provides optimal driving comfort



Well thought out design offers more safety

- The improved operator's cab access is more robust, reducing risk of injury
- Greater stability due to better weight distribution of components

Maintainability



Simple and quick maintenance – means time and cost savings for you

Intelligent installation of components, quicker and easier access to the engine compartment, as well as maximum efficiency in every last detail are key to effective maintenance work. All installed parts which need to be serviced can be reached safely and comfortably from the ground. This saves time and money.



Safe and open service access

- The entire engine compartment can be accessed easily by opening just one Bonnet
- All daily maintenance points can be reached from the ground
- This reduces downtime



Intelligent design means less time spent on maintenance

- Easy and safe maintenance saves time and costs
- Bonnet sealed at the top ensures dirt entering the engine compartment is kept to a minimum



Increased efficiency in every detail

- Engine and components are ideally matched to one another, resulting in maximum efficiency
- More easily accessible filler neck enables quick and easy filling with canisters



24h Liebherr service

- Comprehensive service network provides effective and prompt support
- Replacement part service with round-the-clock delivery
- Fast and reliable service implementation by qualified service specialists

Focus on safety and convenience

Lift arms

Powerful and capable – the intelligently-designed lift arms have a tapered design, which optimises the view of the attachment. The powerful z-bar kinematics ensures safe and rapid material transport.



Stability and tip-over resistance

Stable and secure – a compact machine design and resulting low centre of gravity provide outstanding stability. Bumps and rough terrain are almost imperceptible thanks to the integrated articulating pendulum joint. This ensures maximum safety when transporting material. The result is a huge increase in operational efficiency.



Operator's cab

All-round view – large windows extending down to the footwell as well as an optionally-available reversing camera provide greater safety. The new compact loader's generously-designed cab provides plenty of storage options as well as customizable convenience. The many steering column adjustment options and intuitive controls means new operators will feel at home in a breeze. The redesigned steps make access to the operator's cab even safer.

Technology

Intuitive and intelligent – the redesigned layout of the controls provides an improved view of the working area, ensuring greater safety. It also facilitates faster and more ergonomic work, as well as easy and intuitive operation. The repositioning of display units means all relevant data is easily accessible. The Liebherr control lever with mini joystick enables ergonomic, relaxed, and efficient working with additional hydraulic functions.

Technical data

Diesel engine

	L 504 Compact	L 506 Compact L 508 Compact	L 506 Speeder L 508 Speeder	
Diesel engine	4TNV88C	4TNV86CHT	4TN86CHT	
Design	Water-cooled diesel suction engine			
Cylinder inline	4	4	4	
Fuel injection process	Common Rail direct injection			
Output to	kW / HP	32 / 43	44.5 / 60	52 / 70
ISO 9249 ~ SAE J1349	at RPM	2,650	2,500	2,500
Rated output to				
ISO 14396 / ECE-R.120	kW / HP	34 / 46	47.5 / 64	55 / 74
Nominal speed	at RPM	2,650	2,500	2,500
Max. torque to	Nm	140	207	263
ISO 14396	at RPM	1,950	1,690	1,690
Displacement	litres	2,190	2,091	2,091
Bore / Stroke	mm	88 / 90	86 / 90	86 / 90
Stage V				
Harmful emissions values	According to regulation (EU) 2016 / 1628			
Emission control	Closed diesel particle filter system			
Air cleaner system	Dry type filter with main and safety element			
Electrical system				
Operating voltage	V	12	12	12
Capacity	Ah	1x100	1x100	1x100
Alternator	V/A	12/80	12/80	12/80
Starter	V/kW	12/2.3	12/2.3	12/2.3

Driveline

	L 504 Compact	L 506 Compact L 508 Compact	L 506 Speeder L 508 Speeder
Continuous hydrostatic driveline			
Design	Swash plate type variable flow pump and variable axial piston motor in closed loop circuit		
Filtration	Return filter for the closed circuit		
Control	By travel and inching pedal. The inching pedal makes it possible to control the tractive and thrust forces steplessly to match ground and operating conditions. The Liebherr control lever is used to control forward and reverse travel		
Travel speed range	Speed range 1: 0-6 km/h	Speed range 1: 0-6 km/h	Speed range 1: 0-6 km/h
	Speed range A1-2: 0-20 km/h	Speed range A1-2: 0-20 km/h	Speed range A1-2: 0-30 km/h*
	forward and reverse		
	Speeds quoted apply with the tyres indicated as standard on loader model!		

*Configuration, tyres and attachment tools can influence the maximum speed.

Brakes

	L 504 Compact L 506 Compact L 508 Compact	L 506 Speeder L 508 Speeder
Service brake	Hydrostatic travel drive, acting on all four wheels, non-wearing, additional hydraulic drum brake	Hydrostatic travel drive, acting on all four wheels, non-wearing, additional dual-circuit brake system: Drum brake on the front axle and wet disc brake in rear axle
Parking brake	Negative brake system acting on the drum brake	Negative brake system in the rear axle acting on the wet disc brakes

The braking system meets the requirements of the ISO 3450.

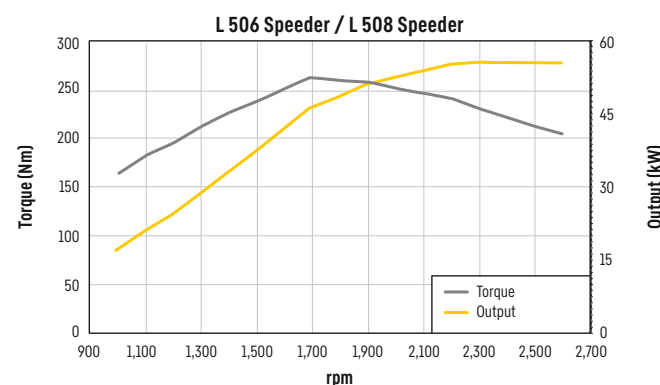
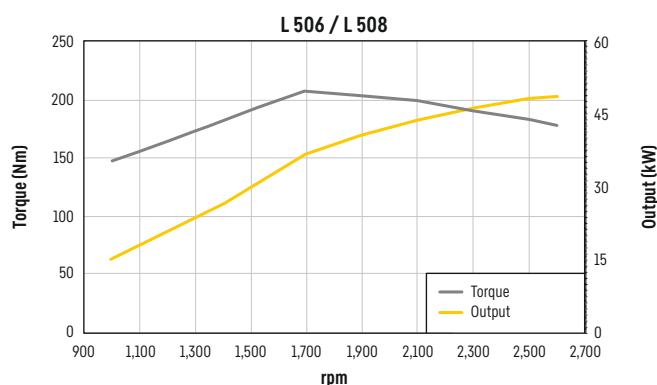
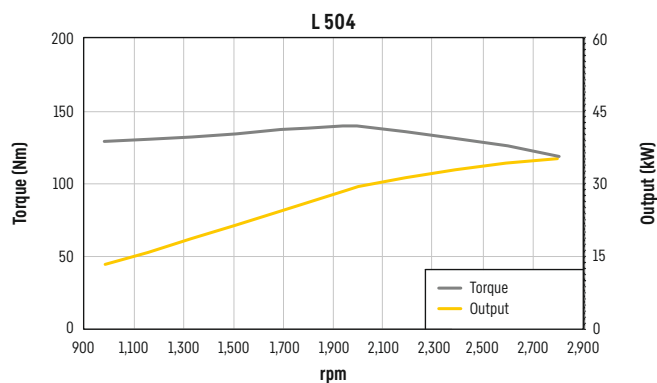

Axles

	L 504 Compact L 506 Compact L 506 Speeder	L 508 Compact L 508 Speeder
Four-wheel drive	Fixed mounted planetary-hub axle	
Design	Fixed mounted planetary-hub axle	
Height of obstacles which can be driven over	mm 320	350
Differentials	with all four wheels keeping contact with the ground Automatic multi-disc limited slip differentials with 45% locking action in both axles	
Reduction gear	Planetary final drive in wheel hubs	
Track width	1,370 mm with tyres indicated as standard (L 504) 1,370 mm with tyres indicated as standard (L 506) 1,500 mm with tyres indicated as standard (L 508)	

Steering

Design	Oscillating center pivot
Angle of articulation	40° to each side
Angle of oscillation – centre-pivot steering	10° to each side
Max. operating pressure	bar 180

Attachment hydraulics

	L 504	L 506	L 508
Design	Gear pump to supply the hydraulic and steering systems (via priority valve)		
Cooling	Hydraulic oil cooling with fan rigidly connected to the diesel engine		
Filtration	Return flow in-line filter		
Control	Single lever control, directly pilot-controlled, 1st and 2nd hydraulic additional function are electrically and proportionally controlled		
Lifting function	Lifting, neutral, lowering Float position controlled by Liebherr control lever with detent		
Tilt function	Tilt back, neutral, dump		
Max. flow	l/min. 61	70	80
Max. pressure	bar 230	230	230

Attachment

	L 504	L 506	L 508
Geometry	Powerful Z-bar linkage with parallel guidance and hydraulic quick hitch as standard		
Bearings	Lathe-turned thick-walled bushings with lubricating grooves		
Cycle time at nominal load	ZK	ZK	ZK
Lifting	s 5.1	5.4	6.5
Dumping	s 1.4	1.7	2.1
Lowering (empty)	s 3.3	3.9	5.9

Operator's cab

Design	Elastic mounted, noise-proof cab. ROPS roll over protection per EN ISO 3471 / EN 474-1 FOPS falling objects protection per EN ISO 3449 / EN 474-1, Cat. II Operator's door with 180° opening angle, right side hinged window with vent opener or 180° opening, single-pane safety glass (ESG), heated rear window (ESG), all panes are tinted. Adjustable steering column optional
Liebherr operator's seat	4 way adjustable, vibration-damped operator's seat "Standard" (mechanically sprung, adjustable to operator's weight)
Cab heating and ventilation	Operator's cabin with defroster and electrically heated rear window, fresh air filter, air recirculation system and hot water heating, cabin ventilation
Vibration emissions	
Hand / arm vibrations	≤ 2.5 m/s ² , according with ISO 5349-1:2001
Whole-body vibrations	≤ 0.5 m/s ² , complies with technical report ISO/TR 25398:2006
Measuring inaccuracy	According with standard EN 12096:1997

Sound level

	L 504	L 506	L 508
Sound pressure level to ISO 6396			
L _{PA} (inside cab)	dB(A) 79	79	79
Sound power level to 2000/14/EG			
L _{WA} (surround noise)	dB(A) 101	101	101

Capacities

	L 504 Compact	L 506 Compact	L 506 Speeder	L 508 Compact	L 508 Speeder
Fuel tank	l 65	65	65	65	65
Engine oil (inclusive filter change)	l 10.2	10.2	10.2	10.2	10.2
Transmission	l 0.5	0.5	0.5	1	1
Coolant	l 10	10	10	10	10
Front axle / differential	l 4.5	4.5	4.5	5.7	5.7
Rear axle / differential	l 4.5	5.0	5.0	5.7	6.7
Front axle / wheel hubs	l 0.5	0.5	0.5	0.5	0.5
Rear axle / wheel hubs	l 0.5	0.5	0.5	0.5	0.5
Hydraulic tank	l 44	44	44	44	44
Hydraulic system, total	l 71	71	71	71	71

Dimensions

Z-bar linkage

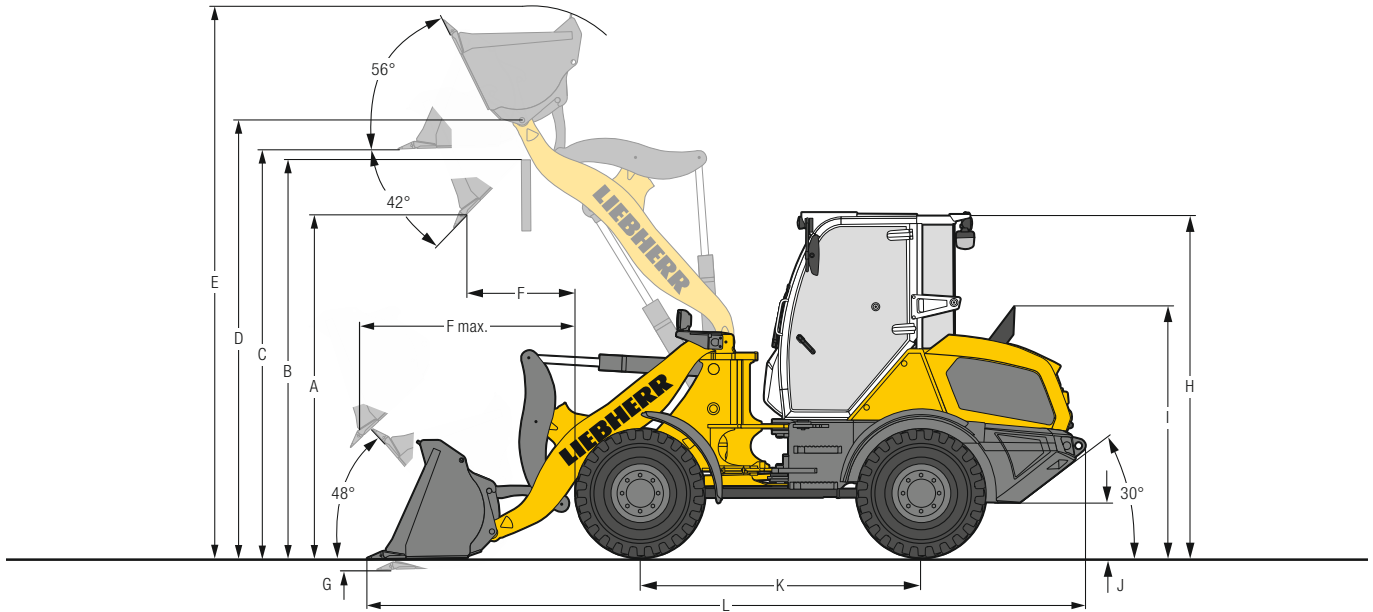

Excavation bucket

	L 504	L 506	L 508
Geometry	ZK-QH	ZK-QH	ZK-QH
Cutting tools	T	T	T
Lift arm length	mm 2,200	2,200	2,300
Bucket capacity according to ISO 7546**	m ³ 0.7	0.8	1.0
Specific material density	t/m ³ 1.8	1.8	1.8
Bucket width	mm 1,800	1,900	2,100
A Dumping height at max. lift height and 42° discharge	mm 2,520	2,505	2,625
B Dump-over height	mm 2,815	2,825	2,980
C Max. height of bucket bottom	mm 2,980	2,990	3,140
D Max. height of bucket pivot point	mm 3,180	3,190	3,340
E Max. operating height	mm 3,980	4,020	4,240
F Reach at max. lift height and 42° discharge	mm 690	720	815
F max. Max. reach at 42° discharge	mm 1,460	1,490	1,605
G Digging depth	mm 65	50	80
H Height above operator's cab	mm 2,480	2,480	2,630
I Height above exhaust	mm 1,890	1,890	1,890
J Ground clearance	mm 325	325	325
K Wheelbase	mm 2,150	2,150	2,150
L Overall length	mm 5,365	5,395	5,495
Turning circle radius over tyres	mm 3,850	3,850	3,945
Turning circle radius over outside bucket edge	mm 4,320	4,370	4,495
Breakout force (SAE)	kN 40	47	57
Tipping load, straight*	kg 3,400	3,950	4,400
Tipping load, fully articulated*	kg 3,000	3,500	3,900
Operating weight*	kg 4,600	4,970	5,700
Tyre size	340/80R18	340/80R18	400/70R18

* The figures shown include the above tyres, all lubricants, a full fuel tank, the ROPS / FOPS cab and the operator. Different tyres and optional equipment will change the operating weight and tipping load. (Tipping load, fully articulated according to ISO 14397-1)

** Actual bucket capacity may be approx. 10% larger than the calculation according to ISO 7546 standard. The degree to which the bucket can be filled depends on the material - see page 22.

ZK-QH = Z-bar linkage incl. quick hitch

T = Welded-on tooth holder with add-on teeth

Dimensions

Z-bar linkage high lift

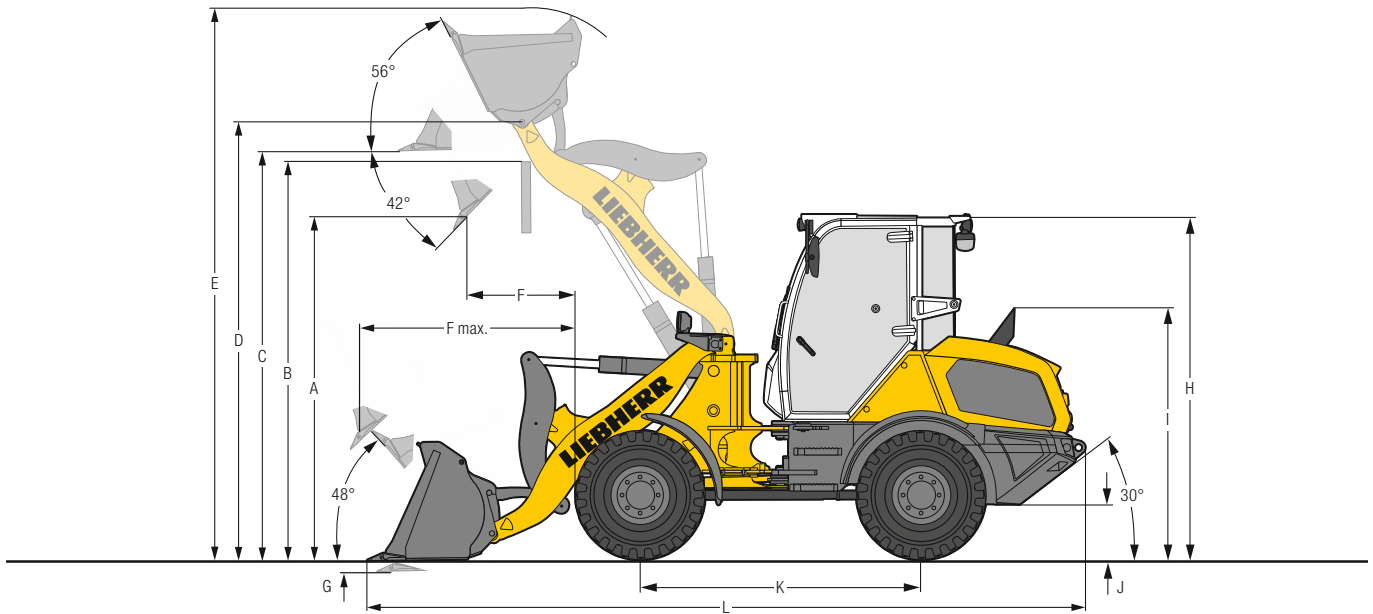

Excavation bucket

	L 506	L 508
Geometry	ZK-QH	ZK-QH
Cutting tools	T	T
Lift arm length	2,320	2,430
Bucket capacity according to ISO 7546**	0.7	0.9
Specific material density	1.8	1.8
Bucket width	1,800	2,050
A Dumping height at max. lift height and 42° discharge	2,680	2,875
B Dump-over height	2,965	3,180
C Max. height of bucket bottom	3,140	3,355
D Max. height of bucket pivot point	3,340	3,555
E Max. operating height	4,140	4,385
F Reach at max. lift height and 42° discharge	695	765
F max. Max. reach at 42° discharge	1,580	1,710
G Digging depth	65	60
H Height above operator's cab	2,480	2,630
I Height above exhaust	1,890	1,890
J Ground clearance	325	325
K Wheelbase	2,150	2,150
L Overall length	5,500	5,605
Turning circle radius over tyres	3,850	3,945
Turning circle radius over outside bucket edge	4,380	4,540
Breakout force (SAE)	50	58
Tipping load, straight*	3,650	4,100
Tipping load, fully articulated*	3,250	3,600
Operating weight*	4,920	5,700
Tyre size	340/80R18	400/70R18

* The figures shown include the above tyres, all lubricants, a full fuel tank, the ROPS / FOPS cab and the operator. Different tyres and optional equipment will change the operating weight and tipping load. (Tipping load, fully articulated according to ISO 14397-1)

** Actual bucket capacity may be approx. 10% larger than the calculation according to ISO 7546 standard. The degree to which the bucket can be filled depends on the material - see page 22.

ZK-QH = Z-bar linkage incl. quick hitch

T = Welded-on tooth holder with add-on teeth

Attachment

4 in 1 bucket

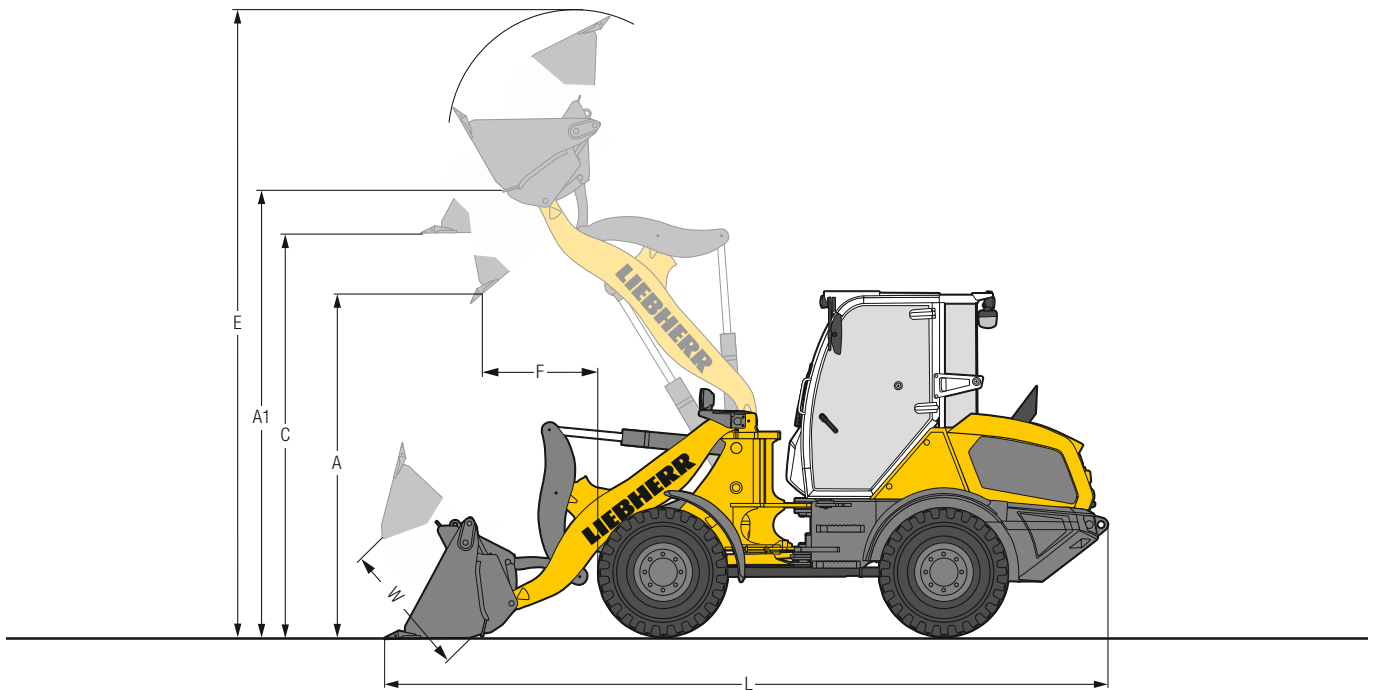

4 in 1 bucket

	L 504	L 506	L 506	L 508	L 508
	STD	STD	HL	STD	HL
Geometry	ZK-QH	ZK-QH	ZK-QH	ZK-QH	ZK-QH
Cutting tools	T	T	T	T	T
Bucket capacity	m ³ 0.7	0.7	0.7	0.9	0.8
Specific material density	t/m ³ 1.6	1.8	1.6	1.8	1.8
Bucket width	mm 1,950	1,950	1,950	2,100	2,100
A Dumping height at max. lift height and 35° discharge	mm 2,445	2,460	2,605	2,600	2,830
A1 Max. dumping height with opened bucket	mm 3,325	3,340	3,485	3,485	3,700
C Max. height of bucket bottom	mm 2,980	2,990	3,140	3,140	3,355
E Max. operating height	mm 4,770	4,780	4,935	4,935	5,150
F Reach at max. lift height and 35° discharge	mm 765	765	770	840	810
L Overall length	mm 5,470	5,460	5,610	5,505	5,670
W Max. bucket opening	mm 1,035	1,035	1,035	1,035	1,035
Turning circle radius over outside bucket edge	mm 4,410	4,410	4,475	4,500	4,580
Tipping load, straight*	kg 3,050	3,600	3,300	4,150	3,820
Tipping load, fully articulated*	kg 2,700	3,150	2,950	3,660	3,370
Operating weight*	kg 4,880	5,230	5,250	5,870	5,890
Tyre size	340/80R18	340/80R18	340/80R18	400/70R18	400/70R18

* The figures shown include the above tyres, all lubricants, a full fuel tank, the ROPS / FOPS cab and the operator. Different tyres and optional equipment will change the operating weight and tipping load. (Tipping load, fully articulated according to ISO 14397-1)

STD = Standard lift arm length

HL = High Lift

ZK-QH = Z-bar linkage incl. quick hitch

T = Welded-on tooth holder with add-on teeth

Attachment

Fork carrier and fork

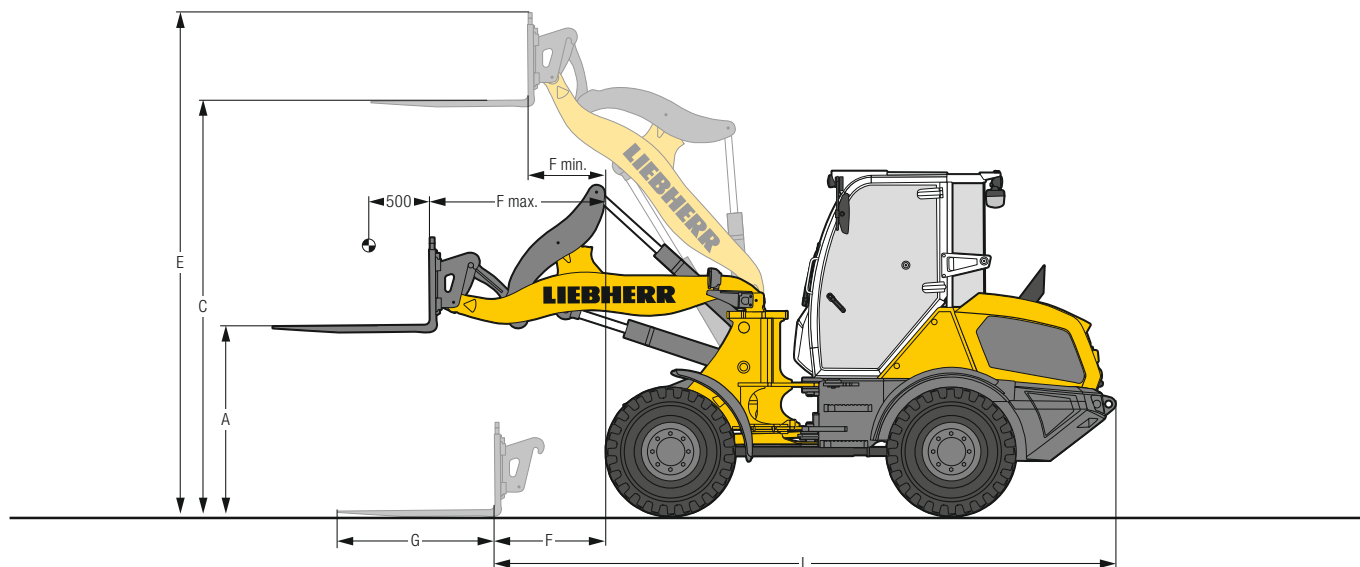

FEM II fork carrier and fork

		L 504	L 506	L 506	L 508	L 508
		STD	STD	HL	STD	HL
		ZK-QH	ZK-QH	ZK-QH	ZK-QH	ZK-QH
Geometry						
A	Lifting height at max. reach	mm	1,355	1,355	1,355	1,465
C	Max. lifting height	mm	3,010	3,020	3,170	3,380
E	Max. operating height	mm	3,675	3,685	3,835	3,840
F	Reach at loading position	mm	795	795	940	830
F max.	Max. reach	mm	1,225	1,225	1,345	1,315
F min.	Reach at max. lifting height	mm	465	465	470	560
G	Fork length	mm	1,200	1,200	1,200	1,200
L	Length - basic machine	mm	4,710	4,710	4,845	4,745
	Tipping load, straight*	kg	2,630	3,050	2,850	3,500
	Tipping load, fully articulated*	kg	2,320	2,700	2,550	3,080
	Recommended payload for uneven ground = 60% of tipping load, articulated ¹⁾	kg	1,400	1,600	1,500	1,850
	Recommended payload for smooth surfaces = 80% of tipping load, articulated ¹⁾	kg	1,850	2,100	2,000	2,450
	Operating weight*	kg	4,580	4,930	4,950	5,580
	Tyre size		340/80R18	340/80R18	340/80R18	400/70R18

* The figures shown include the above tyres, all lubricants, a full fuel tank, the ROPS / FOPS cab and the operator. Different tyres and optional equipment will change the operating weight and tipping load. (Tipping load, fully articulated according to ISO 14397-1)

¹⁾ According to EN 474-3

STD = Standard lift arm length

HL = High Lift

ZK-QH = Z-bar linkage incl. quick hitch

Bucket selection

L 504

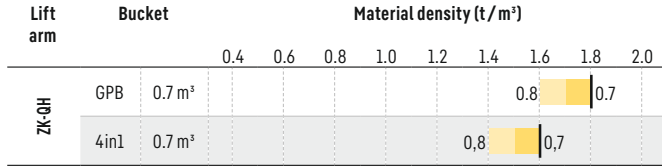

L 506

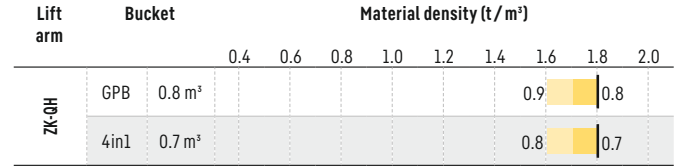

L 508

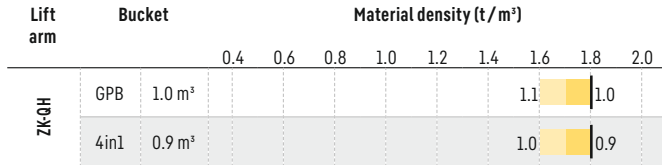

Bucket filling factor

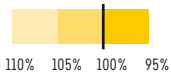

Lift arm

- ZK-QH Z-bar linkage with quick hitch, standard lift arm length
- ZK-QH-HL Z-bar linkage with quick hitch, High Lift

Bucket

- GPB General purpose bucket (Excavation bucket)
- 4in1 4 in 1 bucket

Bulk material densities and bucket filling factors

		t/m³	%			t/m³	%			t/m³	%
Gravel	moist	1.9	105	Earth	dry	1.3	115	Glass waste	broken	1.4	100
	dry	1.6	105		wet excavated	1.6	110		solid	1.0	100
	crushed stone	1.5	100	Topsoil	1.1	110	Compost	dry	0.8	105	
Sand	dry	1.5	105	Basalt	1.95	100	wet	1.0	110		
	wet	1.9	110	Granite	1.8	95	Wood chips / Saw dust		0.5	110	
Gravel and Sand	dry	1.7	105	Sandstone	1.6	100	Paper	shredded / loose	0.6	110	
	wet	2.0	100	Slate	1.75	100	recovered paper / cardboard	1.0	110		
Sand / Clay		1.6	110	Bauxite	1.4	100	Coal	heavy material density	1.2	110	
Clay	natural	1.6	110	Limestone	1.6	100	light material density	0.9	110		
	dry	1.4	110	Gypsum	broken	1.8	100	Waste	domestic waste	0.5	100
Clay / Gravel	dry	1.4	110	Coke		0.5	110	bulky waste	1.0	100	
	wet	1.6	100	Slag	broken	1.8	100				

Tyres



Tyre types

	Size and tread code		Change of operating weight kg	Width over tyres mm	Change in vertical dimensions* mm	Use
L 504 Compact / L 506 Compact / L 506 Speeder						
Dunlop	15.5/55R18 SP PG7	L2	- 36	1,780	- 41	Sand, Gravel, Asphalt (all ground conditions)
Firestone	340/80R18 Duraforce UT	L3	17	1,760	2	Gravel, Asphalt, Industry (all ground conditions)
Firestone	365/80R20 Duraforce UT	L3	76	1,780	40	Gravel, Asphalt, Industry (all ground conditions)
Firestone	400/70R20 Duraforce UT	L3	118	1,810	30	Gravel, Asphalt, Industry (all ground conditions)
Firestone	405/70R18 Duraforce UT	L3	88	1,820	10	Gravel, Asphalt, Industry (all ground conditions)
Firestone	400/70R20 R8000 UT		95	1,810	30	Earthworks, Green area (all ground conditions)
Goodyear	365/80R20	L2	56	1,770	33	Sand, Gravel, Asphalt (all ground conditions)
Goodyear	365/70R18	L2	- 8	1,770	- 16	Sand, Gravel, Asphalt (all ground conditions)
Goodyear	405/70R20	L2	107	1,820	34	Sand, Gravel, Asphalt (all ground conditions)
Goodyear	405/70R18	L2	52	1,810	1	Sand, Gravel, Asphalt (all ground conditions)
Michelin	400/70R20 XMCL		108	1,820	31	Earthworks, Green area (all ground conditions)
Michelin	400/70R20 BIBLOAD	L3	92	1,810	25	Gravel, Asphalt, Industry (firm ground conditions)
Mitas	365/70R18 EM-01	L2	- 4	1,780	- 13	Gravel, Asphalt (all ground conditions)
Mitas	365/80R20 EM-01	L2	56	1,780	39	Gravel, Asphalt (all ground conditions)
Mitas	405/70R18 EM-01	L2	52	1,820	12	Gravel, Asphalt (all ground conditions)
Mitas	405/70R20 EM-01	L2	88	1,820	37	Gravel, Asphalt (all ground conditions)
Nokian	400/70R20 Hakkapeliitta TRI	L2	108	1,810	35	Winter tyres, Gravel, Asphalt (all ground conditions)
Trelleborg	400/70R20 TH400		102	1,810	25	Earthworks, Green area (all ground conditions)
Vredestein	340/80R18 Endurion	L3	0	1,780	0	Gravel, Asphalt, Industry (all ground conditions)
Vredestein	400/70R18 Endurion	L3	64	1,820	5	Gravel, Asphalt, Industry (all ground conditions)
Vredestein	400/70R20 Endurion	L3	104	1,820	40	Gravel, Asphalt, Industry (all ground conditions)
L 508 Compact / L 508 Speeder						
Dunlop	15.5/55R18 SP PG7	L2	- 100	1,920	- 46	Sand, Gravel, Asphalt (all ground conditions)
Firestone	340/80R18 Duraforce UT	L3	- 47	1,900	- 3	Gravel, Asphalt, Industry (all ground conditions)
Firestone	405/70R18 Duraforce UT	L3	24	1,960	5	Gravel, Asphalt, Industry (all ground conditions)
Firestone	365/80R20 Duraforce UT	L3	12	1,920	35	Gravel, Asphalt, Industry (all ground conditions)
Firestone	400/70R20 Duraforce UT	L3	54	1,950	25	Gravel, Asphalt, Industry (all ground conditions)
Firestone	400/70R20 R8000 UT	L2	31	1,950	25	Earthworks, Green area (all ground conditions)
Goodyear	405/70R20	L2	43	1,960	29	Sand, Gravel, Asphalt (all ground conditions)
Goodyear	405/70R18	L2	- 12	1,950	- 4	Sand, Gravel, Asphalt (all ground conditions)
Goodyear	365/80R20	L2	- 8	1,910	28	Sand, Gravel, Asphalt (all ground conditions)
Michelin	400/70R20 XMCL	L2	44	1,960	26	Earthworks, Green area (all ground conditions)
Michelin	400/70R20 BIBLOAD	L3	28	1,950	20	Gravel, Asphalt, Industry (firm ground conditions)
Mitas	405/70R18 EM-01	L2	- 12	1,960	7	Gravel, Asphalt, Industry (all ground conditions)
Mitas	365/80R20 EM-01	L2	- 8	1,920	34	Gravel, Asphalt, Industry (all ground conditions)
Mitas	405/70R20 EM-01	L2	24	1,960	32	Gravel, Asphalt, Industry (all ground conditions)
Nokian	400/70R20 Hakkapeliitta TRI	L2	44	1,950	30	Winter tyres, Gravel, Asphalt (all ground conditions)
Trelleborg	400/70R20 TH400	L2	38	1,950	20	Earthworks, Green area (all ground conditions)
Vredestein	340/80R18 Endurion	L3	- 64	1,920	- 5	Gravel, Asphalt, Industry (all ground conditions)
Vredestein	400/70R18 Endurion	L3	0	1,960	0	Gravel, Asphalt, Industry (all ground conditions)
Vredestein	400/70R20 Endurion	L3	40	1,960	35	Gravel, Asphalt, Industry (all ground conditions)

* The stated values are theoretical and may deviate in practice.

Before operating the vehicle with tyre foam filling or tyre protection chains, please discuss this with the Liebherr-Werk Bischofshofen GmbH.

Tipping load

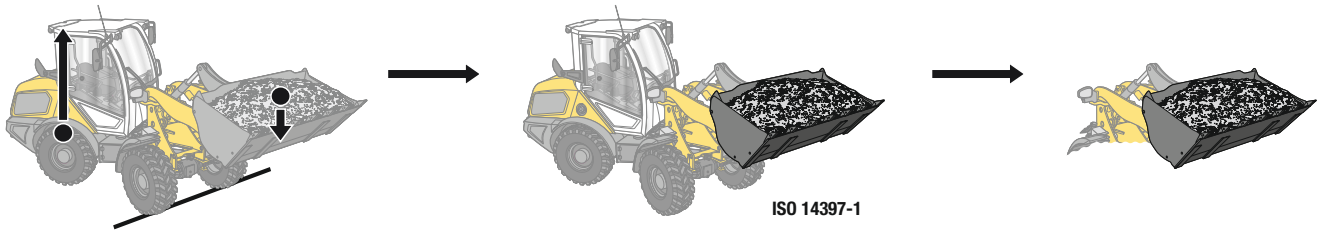

What is tipping load?

Load at centre of gravity of working equipment, so that the wheel loader just begins to tip over the front axle. This is the most unfavourable static-load position for the wheel loader. Lifting arms horizontal, wheel loader fully articulated at centre pivot.

Pay load.

The pay load must not exceed 50% of the tipping load when articulated. This is equivalent to a static stability-margin factor of 2.0.

Bucket capacity.

The bucket volume is determined from the pay load.

$$\text{Pay load} = \frac{\text{Tipping load, articulated}}{2}$$

$$\text{Bucket capacity} = \frac{\text{Pay load (t)}}{\text{Specific bulk weight of material (t/m}^3\text{)}}$$

The Liebherr wheel loaders

Wheel loader



		L 504 Compact	L 506 Compact	L 507 Stereo	L 508 Compact	L 509 Stereo	L 514 Stereo
Tipping load	kg	3,000	3,500	3,750	3,900	4,430	5,750
Bucket capacity	m ³	0.7	0.8	0.9	1.0	1.2	1.5
Operating weight	kg	4,600	4,970	5,550	5,700	6,390	8,860
Engine output	kW / HP	34 / 46	47,5 / 64	50 / 68	47,5 / 64	54 / 73	76 / 103

Wheel loader



		L 518 Stereo	L 526	L 538	L 546	L 550 XPower
Tipping load	kg	6,550	8,730	9,650	11,010	12,500
Bucket capacity	m ³	1.7	2.2	2.6	3.0	3.4
Operating weight	kg	9,190	13,170	14,520	15,410	18,550
Engine output	kW / HP	76 / 103	116 / 158	129 / 175	138 / 188	163 / 222

Wheel loader



		L 556 XPower	L 566 XPower	L 576 XPower	L 580 XPower	L 586 XPower
Tipping load	kg	13,750	15,900	17,600	19,200	21,600
Bucket capacity	m ³	3.7	4.2	4.7	5.2	6.0
Operating weight	kg	19,600	23,900	25,700	27,650	32,600
Engine output	kW / HP	183 / 249	203 / 276	218 / 296	233 / 317	263 / 358

02.22

Equipment



Basic wheel loader

	L 504	L 506	L 508
Automatic central lubrication system	+	+	+
Battery main switch (lockable)	●	●	●
Combined inching-braking system	●	●	●
Connection for electrical equipment 7-pole	+	+	+
Cooling water pre-heating 230 V	+	+	+
Diesel particle filter	●	●	●
Fluff trap for radiator	+	+	+
Fuel pre-filter	●	●	●
Liebherr biodegradable hydraulic oil	+	+	+
Load lashing lugs	●	●	●
Lockable doors and engine hood	●	●	●
Multi-disc limited slip differentials in both axles	●	●	●
Oscillating center pivot	●	●	●
Parking brake	●	●	●
Power socket rear (13-pole, 12V)	+	+	+
Pre-heat system for cold starting	●	●	●
Rear license panel light	+	+	+
Ride control	+	+	+
Special paint	+	+	+
Speeder version (30 km/h)	-	+	+
Tool kit	+	+	+
Towing hitch	+	+	+



Equipment

	L 504	L 506	L 508
1st and 2nd hydraulic, proportional additional function	+	+	+
1st hydraulic, proportional additional function	+	+	+
1st hydraulic, proportional additional function on Liebherr control lever	+	+	+
Bucket return (visual mark on lifting frame)	●	●	●
Control lever lock/continuous mode additional function	+	+	+
Direct control of attachment hydraulics	●	●	●
Float position	●	●	●
Fork carrier and pallet forks	+	+	+
Hydraulic connections rear	+	+	+
Hydraulic quick hitch	●	●	●
Hydraulic quick hitch Solidlink	+	+	+
Lift arm Z-bar linkage with parallel guidance	●	●	●
Lift arm Z-bar linkage, High Lift	-	+	+
Load holding valves	+	+	+
Loading buckets incl. a range of cutting tools	+	+	+
Preparation of Solidlink hydraulic quick coupling system (quick coupler without Solidlink block)	+	+	+
Pressure-free return flow additional function	+	+	+
Working hydraulics lockout	●	●	●



Operator's cab

	L 504	L 506	L 508
3 way continuously adjustable steering column (height-adjustable, tilting, folding)	+	+	+
Air conditioning system (manual)	+	+	+
Amber beacon swiveling LED	+	+	+
Armrest left	+	+	+
Clothes hook	●	●	●
Comfort Grammer operator's seat with longitudinal absorption, seat heating and 2-point seatbelt	+	+	+
Cup holder	●	●	●
Display with tilting and height adjustment function	●	●	●
Electronical theft protection with code	+	+	+
Electronical theft protection with key	+	+	+
Emergency exit	●	●	●
Exterior mirror, tiltable	+	+	+
Exterior mirror, tiltable and heatable	●	●	●
Fire extinguisher in cab 2 kg	+	+	+
First aid kit	+	+	+
Floor mat	●	●	●
Fold-out window right 180°	●	●	●
Headlights front, double design, LED	+	+	+
Headlights front, single design, halogen	●	●	●
Headlights front, single design, LED	+	+	+
Headlights rear, double design, LED	+	+	+
Headlights rear, single design, halogen / LED	+	+	+
Hot-water heater with defroster and recirculated air mode	●	●	●
Interior rear-view mirror	+	+	+
Liebherr Connect			
MyLiebherr Maintenance	+	+	+
MyLiebherr Performance	+	+	+
MyLiebherr Portal*	●	●	●
Liebherr control lever (incl. travel direction)	●	●	●
Liebherr control lever with mini-joystick for additional function	+	+	+
Operating hour meter (integrated in display unit)	●	●	●
Particle filter F5	●	●	●
Power socket 12V	●	●	●
Power socket USB	+	+	+
Preparation for radio installation	+	+	+
Radio "Comfort" (DAB+ / USB / AUX / BLUETOOTH / handsfree set)	+	+	+
Radio Liebherr "Standard" (USB / AUX)	+	+	+
Rear window heated electrically	●	●	●
Soundproof ROPS / FOPS cab	●	●	●
Speed limit & fixed speed	+	+	+
Standard Grammer operator's seat with mechanical absorption and 2-point seatbelt	●	●	●
Steering column fixed	●	●	●
Steering column folding	+	+	+
Storage box	●	●	●
Wipe system front / rear	●	●	●



Safety

	L 504	L 506	L 508
Back-up alarm acoustical / visual	+	+	+
Country-specific versions	+	+	+
Rear space monitoring with camera (with own display)	+	+	+

● = Standard

+ = Option

- = not available

* = activation required free of charge

