

Operating and installation instructions



[home.liebherr.com/
fridge-manuals](https://home.liebherr.com/fridge-manuals)























LIEBHERR

EN

ORIGINAL OPERATOR'S MANUAL

LIEBHERR

Contents

1	Safety information and warnings.....	3		Temperature.....	28
1.1	Intended use.....	3		SuperFrost.....	29
1.2	Climate classes.....	3		PartyMode	29
1.3	User group.....	3		SabbathMode.....	30
1.4	Installation and commissioning.....	3		EnergySaver	30
1.5	Safe handling of the appliance.....	4		IceMaker / MaxIce	31
1.6	Cleaning.....	4		IceMaker water supply.....	32
1.7	Faults, damage and repairs.....	4		TubeClean	32
1.8	Disposal.....	4		Input lock.....	32
1.9	Conformity.....	4		Reminder.....	33
1.10	SVHC substances in accordance with the REACH Regulation.....	4		Language.....	33
1.11	EPREL database.....	4		Temperature unit.....	33
1.12	Open source licences.....	4		Display brightness.....	34
1.13	Spare parts.....	4		WiFi.....	34
1.14	Symbols on the appliance.....	5		Device information.....	35
1.15	Warning levels.....	5		Software.....	35
2	Appliance at a glance.....	5		Start defrosting cycle.....	35
2.1	Scope of delivery.....	5		Door alarm.....	36
2.2	Overview of appliances and equipment.....	5		Demo mode.....	36
2.3	SmartDevice.....	5		Resetting to factory settings.....	37
2.4	Appliance range of use.....	6		Messages.....	37
2.5	Conformity.....	6	8.3.1	Overview of warnings.....	37
2.6	SVHC substances according to REACH regulation.....	6	8.3.2	Ending warnings.....	37
2.7	EPREL database.....	6	8.3.3	Overview of reminders.....	38
2.8	Spare parts.....	6	8.3.4	Ending reminders.....	39
3	Setting up and connecting.....	6	9	Features.....	39
3.1	Installation requirements.....	6	9.1	Wooden grid.....	39
3.2	Appliance dimensions.....	7	9.2	Drawers.....	40
3.3	Ventilation requirements.....	8	9.3	IceMaker.....	40
3.4	Connection dimensions for the power supply.....	8	9.4	Flexible ice compartment divider.....	41
3.5	Water connection.....	8	10	Maintenance.....	41
3.6	Transporting the appliance.....	9	10.1	FreshAir activated carbon filter.....	41
3.7	Unpacking the appliance.....	9	10.2	Disassembling / assembling pull-out systems.....	42
3.8	Door hinge change.....	9	10.3	Defrosting the appliance.....	42
3.9	Connecting the appliance to the water supply.....	20	10.4	Cleaning the appliance.....	43
3.10	Mounting wall spacers*.....	21	11	Customer help.....	44
3.11	Setting up the appliance.....	21	11.1	Technical specifications.....	44
3.12	Setting up the appliance so that it is level.....	21	11.2	Operating noises.....	44
3.13	After setting up.....	21	11.3	Technical fault.....	44
3.14	Installing multiple appliances.....	22	11.4	Customer Service.....	46
3.15	Integrating the appliance into a kitchen unit.....	22	11.5	Model plate.....	46
3.16	Disposing of packaging.....	23			
3.17	Connecting the appliance to the power supply.....	23			
4	Functionality of the Touch & Swipe display.....	24			
4.1	Navigation and symbol explanation.....	24			
4.2	Menus.....	24			
4.3	Sleep mode.....	25			
5	Putting into operation.....	25			
5.1	Switching on appliance (first use).....	25			
5.2	Starting the IceMaker for the first time.....	25			
6	Storage.....	26			
6.1	Information regarding storage.....	26			
6.2	Freezer compartment.....	26			
6.3	Storage times.....	26			
7	Saving energy.....	27			
8	Controls.....	27			
8.1	Controls and displays.....	27			
8.1.1	Status display.....	27			
8.1.2	Display symbols.....	27			
8.2	Appliance functions.....	27			
8.2.1	Notes on the appliance functions.....	27			
	Switching the appliance off and on.....	27			
	Switching temperature zone off and on.....	28			

Safety information and warnings

- Do not place portable multiple sockets or power supply units at the rear of the appliance.
- It must be easy to access the socket so that the appliance can be quickly disconnected from the power supply in case of an emergency. It must not be behind the appliance.

1.5 Safe handling of the appliance

- Do not store any explosive substances, such as aerosol containers with flammable propellant gas, in the appliance. These types of aerosol can be identified by the list of contents printed on it, or by a flame symbol. Any leaking gas may ignite due to electrical parts.
- Keep burning candles, lamps and other objects with naked flames away from the appliance, so that these do not set fire to the appliance.
- Alcoholic beverages and other containers bearing alcohol must be sealed tight for storage. Any leaking alcohol may ignite due to electrical parts.
- Avoid prolonged skin contact with cold surfaces or with cold/frozen food. Use gloves for protection, for example.
- The refrigerant contained (information on the type plate) is environmentally friendly but flammable. Leaking refrigerant may ignite.
 - Do not damage the refrigeration circuit.
 - Do not use any ignition sources inside the appliance.
 - Do not use electrical appliances inside the appliance (e.g. steam cleaners, heaters).
 - If the refrigerant leaks: remove any naked flames or ignition sources from the vicinity of the leakage point. Properly air the room. Inform customer service.
- Only open the door for a short time. This prevents the temperature inside the appliance from rising.
- Do not reach between the door and the appliance when opening and closing. Fingers may become trapped.
- The temperature in the warmest part of the appliance may be higher than the set temperature.

1.6 Cleaning

- Regularly clean surfaces that come into contact with food.
- Do not use an electric heater or steam cleaner, naked flames or defrost spray to speed up the defrosting process.
- Do not remove the ice with sharp objects.

1.7 Faults, damage and repairs

- If the mains connection cable of the appliance is damaged, replace the mains connection cable.
- Repairs and interventions on the appliance may only be carried out by the customer service or by other qualified personnel trained for this purpose.
- In the event of malfunctions and appliance faults, pull out the mains plug or switch off the fuse. Always hold the plug when pulling out the mains plug. Never tug on the cable.

1.8 Disposal

- The appliance contains valuable materials and is marked with the appropriate symbol. (see 1.14 Symbols on the appliance)
 - Do not dispose of the appliance in the household waste.
 - Dispose of the appliance free of charge at your local recycling centre using the Class 1 collection containers.

- When purchasing a new appliance, return the old appliance to the retailer free of charge.
- Provide information about return options.
- Your appliance may contain personal data.
 - Delete personal data before disposal.
- The appliance contains refrigerant (information on the type plate) and oil. The refrigerant inside the appliance is environmentally friendly, but flammable. The oil it contains is also flammable. Escaping refrigerant and oil can ignite in high concentrations and in contact with an external heat source.
 - Do not damage the refrigeration circuit.
 - Only dispose of the appliance in accordance with the instructions in the user information.

1.9 Conformity

The coolant circuit has been tested for leak-tightness. The appliance complies with the relevant safety regulations and directives.

For the EU market: The appliance complies with Directive 2014/53/EU.

For GB market: The appliance complies with the Radio Equipment Regulations 2017 SI 2017 No. 1206.

The full text of the EU Declaration of Conformity is available at the following web address: www.liebherr.com

1.10 SVHC substances in accordance with the REACH Regulation

- You can use the following link to check whether your appliance contains SVHC substances in accordance with the REACH Regulation:
<https://go.liebherr.com/z3eewm>

1.11 EPREL database

- From 1 March 2021, the information on energy labelling and eco-design requirements will be available in the European product database (EPREL). The product database can be accessed via the following link <https://eprel.ec.europa.eu/>. Here, you are asked to enter the model identifier. You will find the model identifier on the type plate.

1.12 Open source licences

- The appliance contains software components that use open source licences. Information on the open source licences used can be found here:
home.liebherr.com/open-source-licences

1.13 Spare parts

- The spare parts availability for functional parts and stockable parts of the equipment is 15 years.

1.14 Symbols on the appliance

	This symbol may be found on the compressor. It pertains to the oil in the compressor and indicates the following danger: Can be fatal if swallowed or with penetration of the respiratory tract. This information is only significant for recycling. No risk exists with normal use. Do not remove this symbol.
	Warning: Fire hazard due to flammable substances. This symbol is located on the compressor and can also be found in other places on the appliance. This symbol warns of flammable substances. Do not remove this symbol.
	This or a similar symbol may be on the rear of the appliance. It indicates that there are vacuum insulation panels (VIP) or perlite panels in the door and/or housing. This information is only significant for recycling. Do not remove this symbol.
	This symbol is located on the type plate. It indicates that the appliance contains valuable materials and that you must not dispose of it with household waste. (see 1.8 Disposal)

1.15 Warning levels

	DANGER	Identifies an immediately dangerous situation that will result in death or serious bodily injuries if it is not prevented.
	WARNING	Identifies a dangerous situation that could result in death or serious bodily injury if it is not prevented.
	CAUTION	Identifies an immediately dangerous situation that could result in slight or moderate injuries if it is not prevented.
	ATTENTION	Identifies a hazardous situation that could result in property damage if it is not prevented.
	Note	Identifies useful information and tips.

2 Appliance at a glance

2.1 Scope of delivery

Check all parts for transport damage. Contact your dealer or customer service in the event of complaints. (see 11.4 Customer Service)

Your new appliance comes with the following parts:

- Standalone appliance
- Features (depending on the model)
- Installation materials (depending on the model)
- "Quick Start Guide"
- "Installation Guide"*
- Service Brochure

* Depending on model and options

2.2 Overview of appliances and equipment

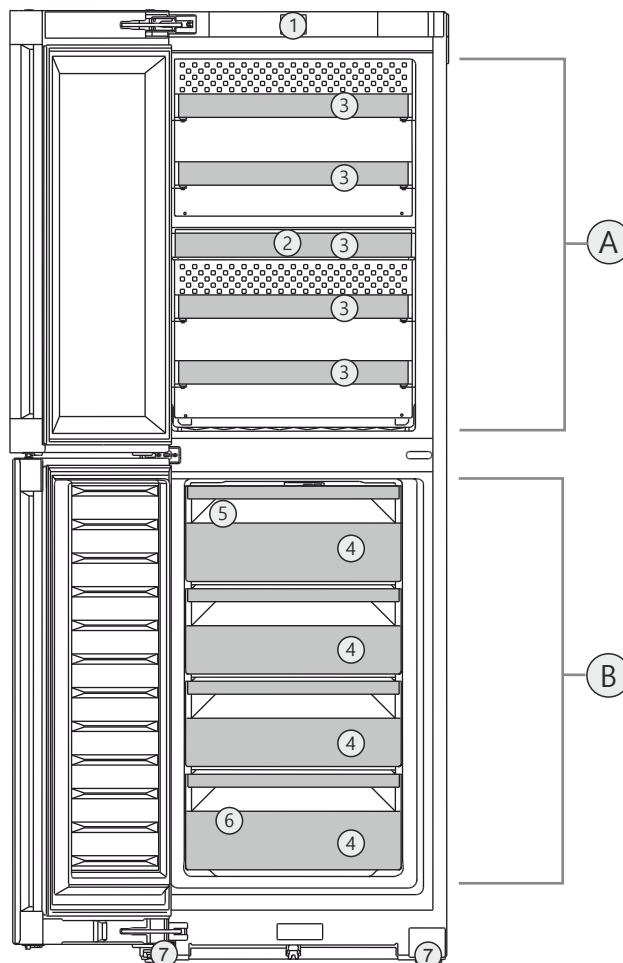

Fig. 1 Example illustration

Temperature range

- (A) Wine compartment (B) Freezing compartment

Equipment

- (1) Controls
 (2) FreshAir activated carbon filter
 (3) Bottle rack
 (4) Freezer drawer
 (5) IceMaker
 (6) Type plate
 (7) Adjustable feet (front), transport rollers (rear), carrying loops at the top (rear) and bottom (front)

2.3 SmartDevice

SmartDevice is the networking solution for your wine cabinet-freezer combination.

If your appliance SmartDevice-enabled or compatible, you can quickly and easily connect your appliance to your WiFi. With the SmartDevice app, you can operate your appliance from a mobile device. Additional functions and setting options are available in the SmartDevice SmartDevice app.

SmartDevice-enabled appliance: Your appliance is capable of being a SmartDevice. To be able to connect your device to WiFi, you need to download the SmartDevice app.

More information about SmartDevice: smartdevice.liebherr.com

Setting up and connecting

Downloading the SmartDevice app:



After installing and configuring the SmartDevice app, you can connect your appliance to your Wi-Fi (see WiFi) using the SmartDevice app and the appliance's Wi-Fi function.

Note

The SmartDevice function is not available in the following countries: Russia, Belarus, Kazakhstan.

2.4 Appliance range of use

Intended use

The appliance must only be used in a domestic or a normal household setting. Only drinks such as wine must be stored in the wine compartment. Only frozen food must be stored in the freezer compartment. This includes, for example, using

- in staff kitchens, bed and breakfast establishments,
- by guests in country houses, hotels, motels and other accommodation,
- for catering and similar services in the wholesale trade.

The appliance is not suitable as a built-in unit.

All other types of use are not permitted.

Foreseeable misuse

The following applications are expressly forbidden:

- Storing and refrigerating medicines, blood plasma, laboratory preparations or similar substances and products based on the Medical Device Directive 2007/47/EC
- Use in areas at risk of explosions

Misusing the appliance may lead to damage to the goods stored or they may spoil.

Climate classifications

Depending on the climate classification the appliance is designed to operate in restricted ambient temperatures. The climate classification applying to your appliance is printed on the rating plate.

Note

- Keep to the specified ambient temperatures in order to guarantee that the appliance works properly.

Climate classification	for ambient temperatures of
SN	10 °C to 32 °C
N	16 °C to 32 °C
ST	16 °C to 38 °C
T	16 °C to 43 °C
SN-ST	10 °C to 38 °C
SN-T	10 °C to 43 °C

2.5 Conformity

The refrigerant circuit has been tested for leaks. The appliance complies with the applicable safety regulations and with the corresponding directives.

For the EU market:

The appliance complies with directive 2014/53/EU.

For the GB market:

The appliance complies with Radio Equipment Regulations 2017 SI 2017 No. 1206.

The full text of the EU Declaration of Conformity is available on the following website: www.Liebherr.com

2.6 SVHC substances according to REACH regulation

You can check whether your appliance contains SVHC substances according to REACH regulation at the following link: <https://go.liebherr.com/z3eewm>

2.7 EPREL database

Details about energy labelling and ecodesign requirements will be available on the European product database (EPREL) from 1st March 2021. You can access the product database at the following link: <https://eprel.ec.europa.eu/> You will be asked to enter the model ID. You can find the model ID on the nameplate.

2.8 Spare parts

The spare parts availability for functional parts and stockable parts of the equipment is 15 years.

3 Setting up and connecting

3.1 Installation requirements

The installation conditions are crucial to ensure that you can operate your appliance safely, efficiently and without problems.

- Observe all safety instructions.
- Consider the location and position in the room.



WARNING

Danger of fire due to incorrect positioning!

If the mains cable or plug touches the back of the appliance, the vibration can damage the mains cable or the plug resulting in a short circuit.

- Make sure the mains cable is not trapped under the appliance when you position the appliance.
- Stand the appliance so that it is not touched by connectors or main cables.
- Do not connect any appliances to sockets in the area of the back of the appliance.
- Do **not** place and operate multi-sockets/power distributors and other electronic devices (such as halogen transformers) at the back of the appliances.



WARNING

Fire hazard due to dampness!

If live parts or the mains lead become damp this may cause short circuits.

- The appliance is designed for use in enclosed areas. Do not operate the appliance outdoors or in areas where it is exposed to splash water or damp conditions.



WARNING

Leaking coolant and oil!

Fire. The coolant contained in the appliance is eco-friendly, but also flammable. The oil contained in the appliance is flammable. Escaping coolant and oil can ignite if the concentration is high enough and in contact with an external heat source.

- ▶ Do not damage the pipelines of the coolant circuit and the compressor.

3.1.1 Installation site

- Only set up and use the appliance in enclosed spaces.
- A dry and well-ventilated room is an optimum installation location.
- If the appliance is installed in a very damp environment, condensation may form on the appliance exterior. Always make sure there is good ventilation and aeration at the installation site.
- The more refrigerant there is in the appliance, the larger than room must be in which it is located. In rooms that are too small, a leak can produce a flammable gas/air mixture. For every 8 g of refrigerant, the installation room must be at least 1 m³ in size. Information on the refrigerant contained is given on the type plate inside the appliance.
- The floor on which the appliance stands must be horizontal and level.

3.1.2 Position in space

- Do not place the appliance in direct sunlight or near radiators or similar sources of heat.
- You can place the appliance directly next to an oven.
- If the appliance is placed directly next to an oven, the energy consumption may increase slightly. This is dependent on the service life and usage intensity of the oven.
- Always position the appliance with the rear directly against the wall, or with wall spacer brackets attached (see below) then with these directly against the wall.*
- Always position the appliance with the rear directly on the wall.*
- Use in hazardous areas is not permitted.

3.1.3 Integration into a kitchen unit

- You can convert the appliance with kitchen cabinets. (see 3.15 Integrating the appliance into a kitchen unit)

3.2 Appliance dimensions

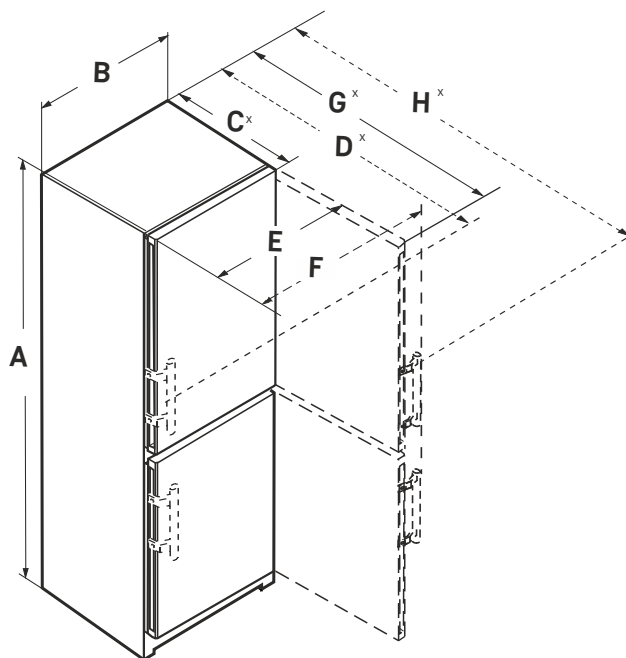

Fig. 2

SWN.. 52..i	
A (mm)	1855
B (mm)	597
C (mm)	675 ^x
D (mm)	719 ^x
E (mm)	609
F (mm)	654
G (mm)	1215 ^x
H (mm)	1222 ^x

For appliances with a lever handle

CN.. 52.. / SCN.. 52..(i) / SBN.. 52..(i)	
A (mm)	1855
B (mm)	597
C (mm)	675 ^x
D (mm)	719 ^x
E (mm)	609
F (mm)	654
G (mm)	1215 ^x
H (mm)	1222 ^x

For appliances with a lever handle

CN.. 57.. / CBN.. 57..(i)	
A (mm)	2015
B (mm)	597
C (mm)	675 ^x
D (mm)	719 ^x
E (mm)	609

Setting up and connecting

CN.. 57.. / CBN.. 57.. (i)	
F (mm)	654
G (mm)	1215*
H (mm)	1222*

For appliances with a lever handle

CN.. 77..(i) / CBN.. 77.. (i)	
A (mm)	2015
B (mm)	747
C (mm)	675*
D (mm)	719*
E (mm)	759
F (mm)	804
G (mm)	1365*
H (mm)	1372*

For appliances with a lever handle

* For appliances with enclosed wall spacers, the dimension is increased by 15 mm (see 3.10 Mounting wall spacers*).

3.3 Ventilation requirements

NOTICE

Danger of overheating due to insufficient air ventilation! The compressor may be damaged if there is insufficient air ventilation.

- ▶ Take care to ensure adequate air ventilation.
- ▶ Observe the ventilation requirements.

If the appliance is integrated into a kitchen unit, the following ventilation requirements must be observed:*

- As a general rule: the larger the ventilation cross section, the more energy the appliance will be able to save.*

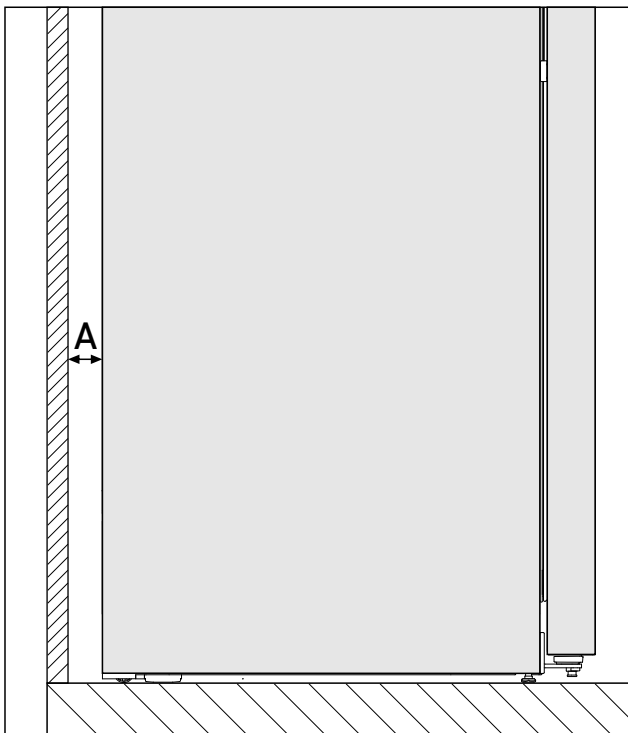

Fig. 3 *

Wall gap A*
25 mm*

The energy consumption has been determined with a gap of Fig. 3 (A) between the rear of the appliance and the wall. If the wall gap is less than Fig. 3 (A), this does not affect the appliance's operability but the energy consumption does increase slightly at a smaller wall gap.*

3.4 Connection dimensions for the power supply

The connection to the power supply is on the rear of the appliance. To connect your appliance safely, ensure that the following requirements are met:

- ❑ Dimensions for the connection to the power supply are known and are adhered to. See table below.
- ❑ Connection to the power supply according to the instructions. (see 3.17 Connecting the appliance to the power supply)

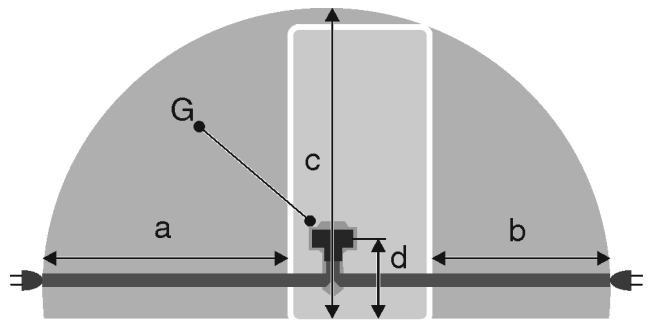

Fig. 4 Fridge/freezer combinations / freezers / full-capacity BioFresh appliances

- (a) Maximum available length of the mains connection cable
- (b) Maximum available length of the mains connection cable
- (c) Maximum available vertical length of the mains connection cable
- (d) Gap between appliance plug and floor
- (G) Appliance plug

For 600 mm wide appliances:	
a	~ 1800 mm
b	~ 1400 mm
c	~ 2100 mm
d	~ 200 mm

3.5 Water connection

If your appliance has a fixed water connection, a hose is supplied with it.

Note

You can purchase a hose of a different length as an accessory.

If your appliance has a fixed water connection an elbow connector with filter is supplied with it.

Overview of dimensions for the water connection:	(see 3.5 Water connection)
--	----------------------------

Requirements for the water pressure:	(see 3.5 Water connection)
Make the water connection:	(see 3.9 Connecting the appliance to the water supply)

3.5.1 Dimensions for the water connection

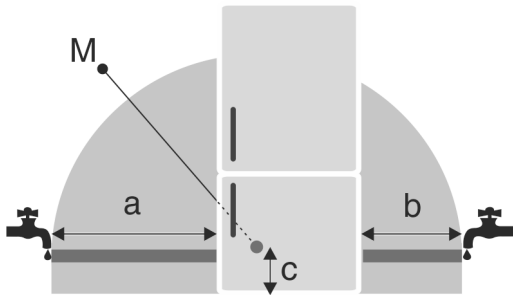

Fig. 5

- (a)** Maximum available hose length
(b) Maximum available hose length
(c) Distance of solenoid valve to floor
(M) Solenoid valve

For 600 mm wide appliances:

a	b	c
~ 1650 mm	~ 1500 mm	~ 150 mm

3.5.2 Water pressure

The water connection line and solenoid valve of the appliance are suitable for a water pressure of up to 1 MPa (10 bar).

To ensure that the appliance functions correctly (flow rate, ice cube size, noise level), maintain the following water pressure:

Water pressure:		
bar	psi	MPa
1.5 to 6.2	21.76 to 87.02	0.15 to 0.62

Water pressure:	
bar	MPa
1.5 to 6.2	0.15 to 0.62

If the pressure is higher than 6.2 bar:

- ▶ Fit a pressure reducer.
- ▶ Make the water connection. (see 3.9 Connecting the appliance to the water supply)

3.6 Transporting the appliance



WARNING

Risk of injury due to broken glass!*

When transporting at an altitude of more than 1500 m, the glass panes of the door may break. This can result in sharp-edged fragments, which can cause serious injuries.

- ▶ Take appropriate protective action.

3.6.1 Transporting the appliance for initial use

Ensure that the following requirements are met:

- The appliance is packaged.
- The appliance is upright.

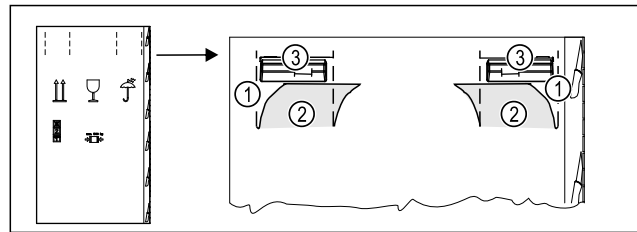

Fig. 6

- ▶ Press the packaging cardboard into the perforation Fig. 6 (1) at the top.
- ▶ Pull out any tabs Fig. 6 (2) that have been pushed in.
- ▶ Carrying handle Fig. 6 (3) visible on the right and left.
- ▶ Hold the appliance by the carrying handles Fig. 6 (3).
- ▶ Transport the appliance with the help of two people.
- ▶ Unpacking the appliance. (see 3.7 Unpacking the appliance)

3.6.2 Transporting the appliance after initial use

Observe the following instructions if you wish to transport or move the appliance again after initial use.

Ensure that the following requirements are met:

- The appliance is emptied.
- The appliance is upright.
- Appliance with door(s): Door is secured against accidental opening.
- Appliance with telescopic unit: The telescopic unit is secured against accidental opening.
- Appliance with adjustable feet: Adjustable feet are screwed in.
- ▶ Hold the appliance by the carrying handles.
- ▶ Transport the appliance with the help of two people.

After transport:

- ▶ Unscrew the adjustable feet on the appliance.
- ▶ Align the appliance. (see 3.12 Setting up the appliance so that it is level)

3.7 Unpacking the appliance

Before you connect the appliance, report any damage immediately to the delivery company.

- ▶ Check the appliance and the packaging for damage during transport. Contact the supplier immediately if you suspect any level of damage.
- ▶ Remove all materials from the back or the side walls of the appliance that may prevent proper installation or ventilation.
- ▶ Remove all protective films from the appliance. Do not use sharp or pointed objects for this.

3.8 Door hinge change

Tools



Setting up and connecting

Fig. 7

NOTICE

Risk of damage due to door collision!
Damage to the appliances with Side-by-Side positioning. If you set up two appliances next to each other in a specific Side-by-Side arrangement, the door hinge of both appliances is preset at the factory.

- ▶ Side-by-Side positioning: Do not change the door hinge.

These sections apply for appliances **with a soft stop mechanism**:

- For appliances **with** a soft stop mechanism
- For all appliances

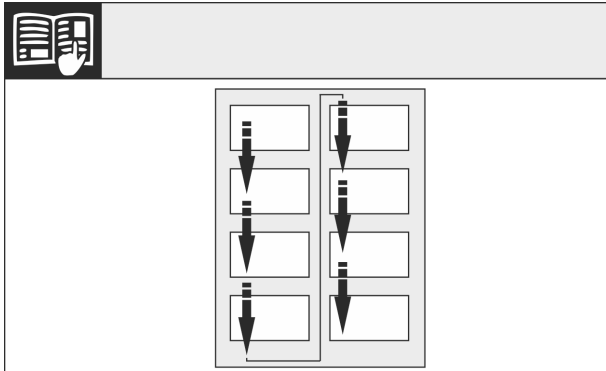

Fig. 8

Remember the reading direction.

3.8.1 Removing the upper soft stop mechanism*

For appliances with a soft stop mechanism:*

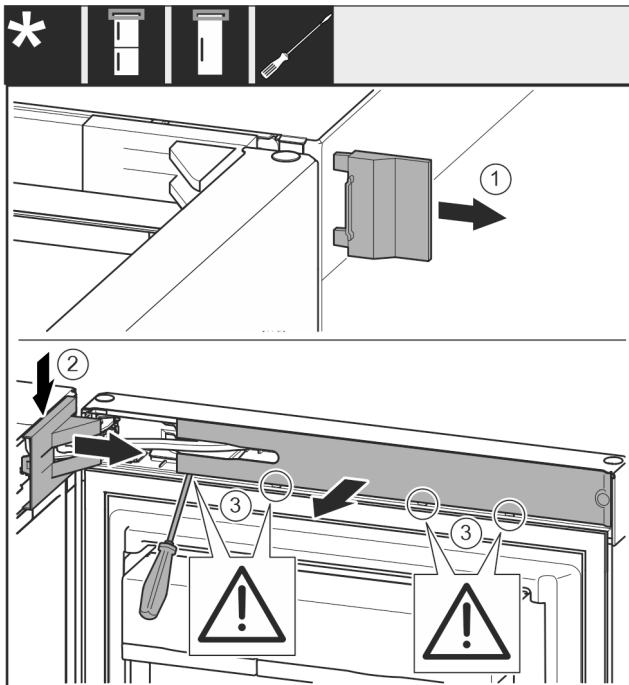

Fig. 9

- ▶ Open the top door.

NOTICE

Risk of damage from screwdrivers!
If you damage the door seal, the door will not close properly resulting in inadequate cooling.

- ▶ Use a screwdriver carefully as an aid.
- ▶ Do not damage the door seal with the screwdriver.

- ▶ Remove cover Fig. 9 (1).
- ▶ Disengage and loosen the swap bearing block cover Fig. 9 (2).
- ▶ Remove the swap bearing block cover Fig. 9 (2).
- ▶ Use a slotted screwdriver to unlatch the trim Fig. 9 (3) and swing it to the side.

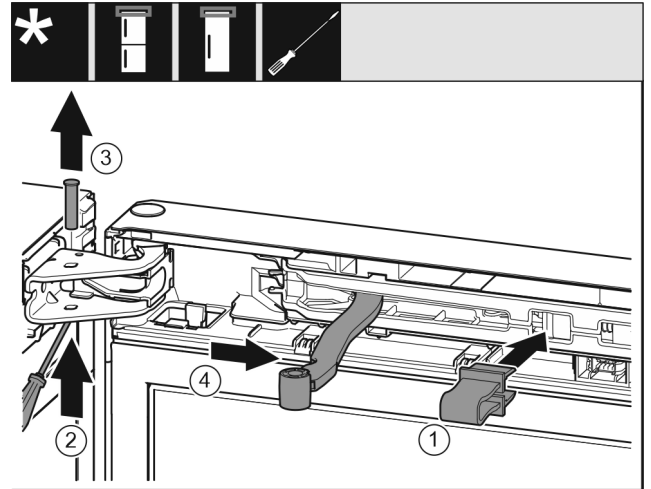

Fig. 10



CAUTION

Crushing hazard by joint folding up!

- ▶ Engage safety device.

- ▶ Latch safeguard Fig. 10 (1) into opening.
- ▶ Slide out the bolt Fig. 10 (2).
- ▶ Remove the bolt Fig. 10 (3) upwards.
- ▶ Turn the joint Fig. 10 (4) towards the door.

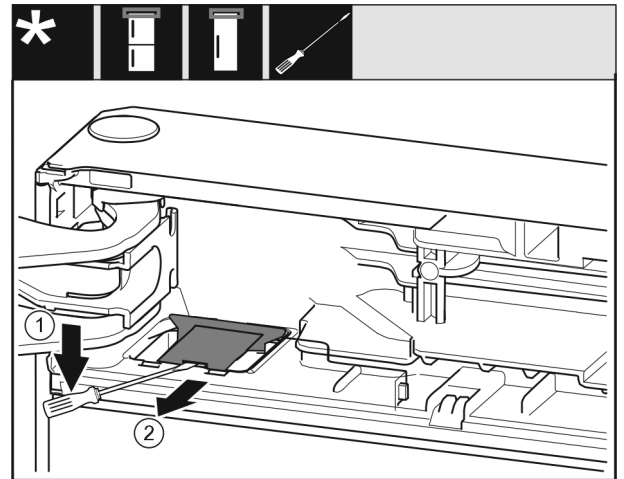

Fig. 11

- ▶ Use a flat-blade screwdriver to disengage the cover Fig. 11 (1).
- ▶ Remove the cover Fig. 11 (2).

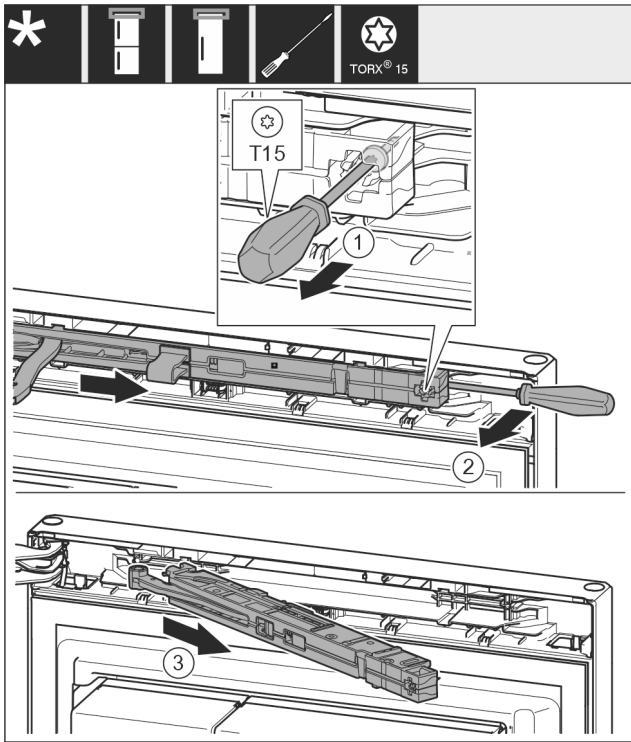

Fig. 12

- ▶ Use screwdriver to loosen the screw Fig. 12 (1) on the closing damper unit by 14 mm.
- ▶ Lever the closing damper unit Fig. 12 (2) forwards on the handle side using a screwdriver.
- ▶ Pull out the closing damper unit Fig. 12 (3).

3.8.2 Removing the bottom soft stop mechanism

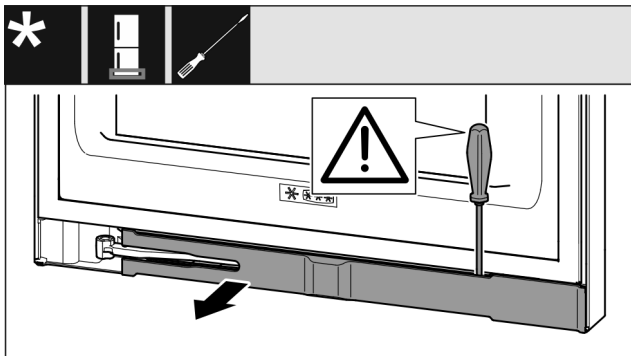

Fig. 13

- ▶ Open the bottom door.

NOTICE

Risk of damage from screwdrivers!*

If you damage the door seal, the door will not close properly resulting in inadequate cooling.

- ▶ Use a screwdriver carefully as an aid.
 - ▶ Do not damage the door seal with the screwdriver.
-
- ▶ Use a slotted screwdriver to unlatch the trim and swing it to the side. (see Fig. 13)



Fig. 14



CAUTION

Crushing hazard by joint folding up!

▶ Engage safety device.

- ▶ Latch safeguard into opening. (see Fig. 14)

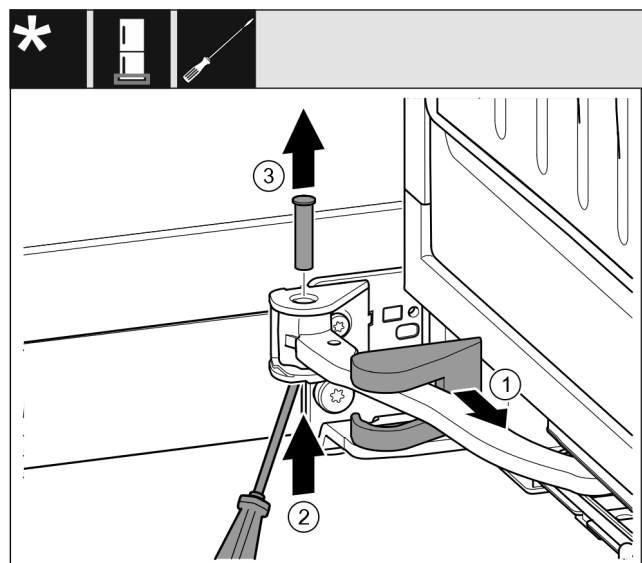

Fig. 15

- ▶ Remove the swap bearing block cover Fig. 15 (1) and slide along the joint.
- ▶ Use a screwdriver to lift the bolt Fig. 15 (2) from below.
- ▶ Pull out the bolt Fig. 15 (3) from above.

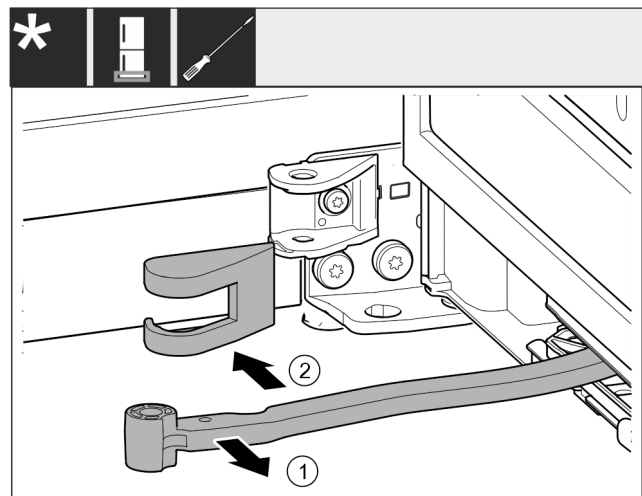

Fig. 16

- ▶ Turn the joint Fig. 16 (1) towards the door.
- ▶ Remove the swap bearing block cover Fig. 16 (2).

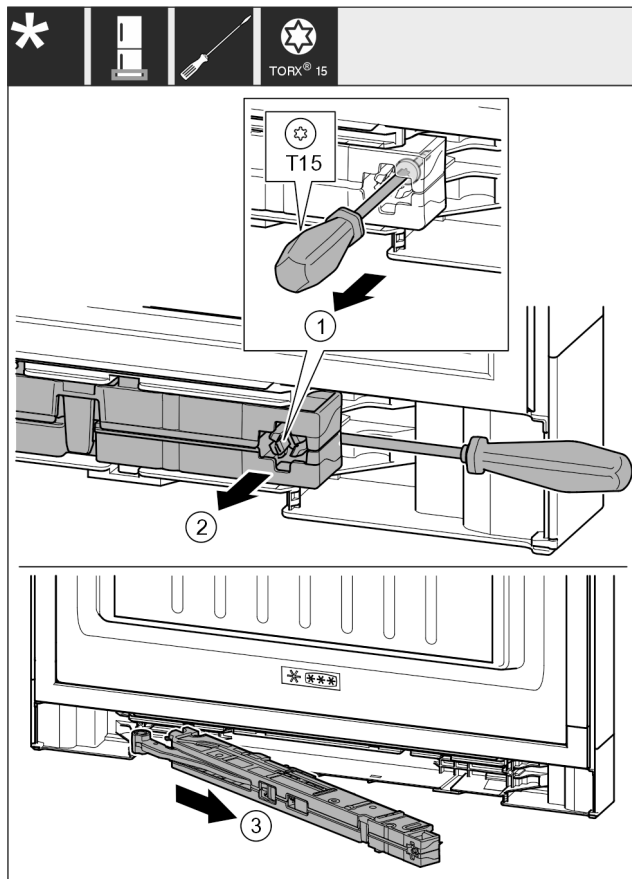

Fig. 17

- ▶ Use screwdriver to loosen the screw Fig. 17 (1) on the closing damper unit by 14 mm.
- ▶ Lever the closing damper unit Fig. 17 (2) forwards on the handle side using a screwdriver.
- ▶ Pull out the closing damper unit Fig. 17 (3).
- ▶ Place the soft stop mechanism to one side.

3.8.3 Undoing the cable connection

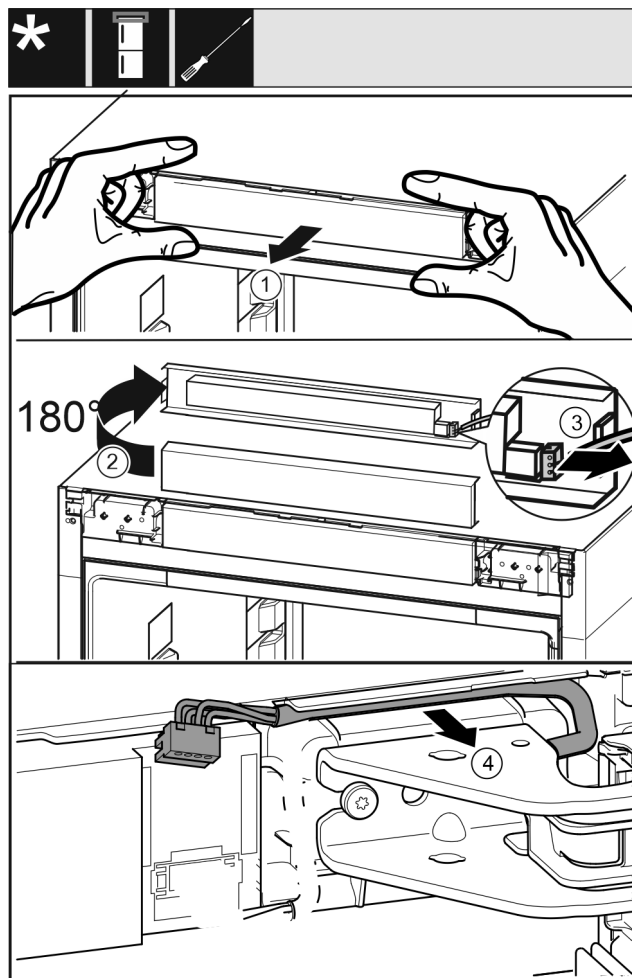

Fig. 18

- ▶ Carefully release the control panel trim Fig. 18 (1) forwards.
- ▶ Turn the control panel trim Fig. 18 (2) upwards by 180°.
- ▶ Push the locking tab Fig. 18 (3) backwards and remove the plug carefully.
- ▶ Release the cable over the swap bearing block Fig. 18 (4) from the guide carefully.

-or-

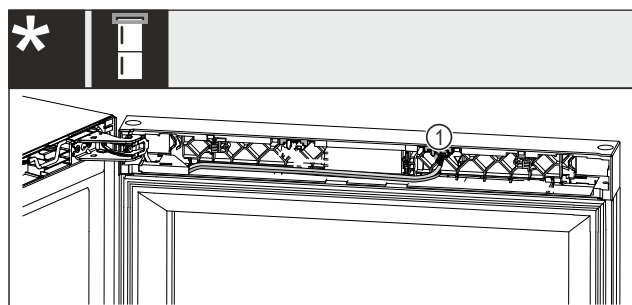

Fig. 19 Wine-freezer combinations

NOTICE

Risk of damage due to interrupted power supply!
Damaged door lighting or operating electronics.

- ▶ Do not pull out the end of the cable that is built into the door.

- ▶ Pull the plug Fig. 19 (1) out of the retaining clip.

For all appliances:

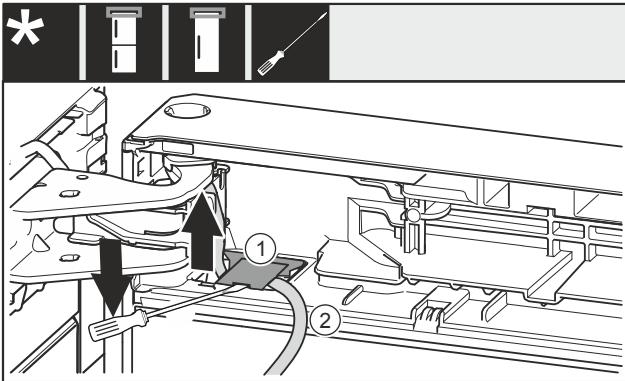

Fig. 20

- ▶ Use the slotted screwdriver to lift the cover Fig. 20 (1) up and pull it out.
- ▶ Pull out the cable Fig. 20 (2).

3.8.4 Removing the upper door

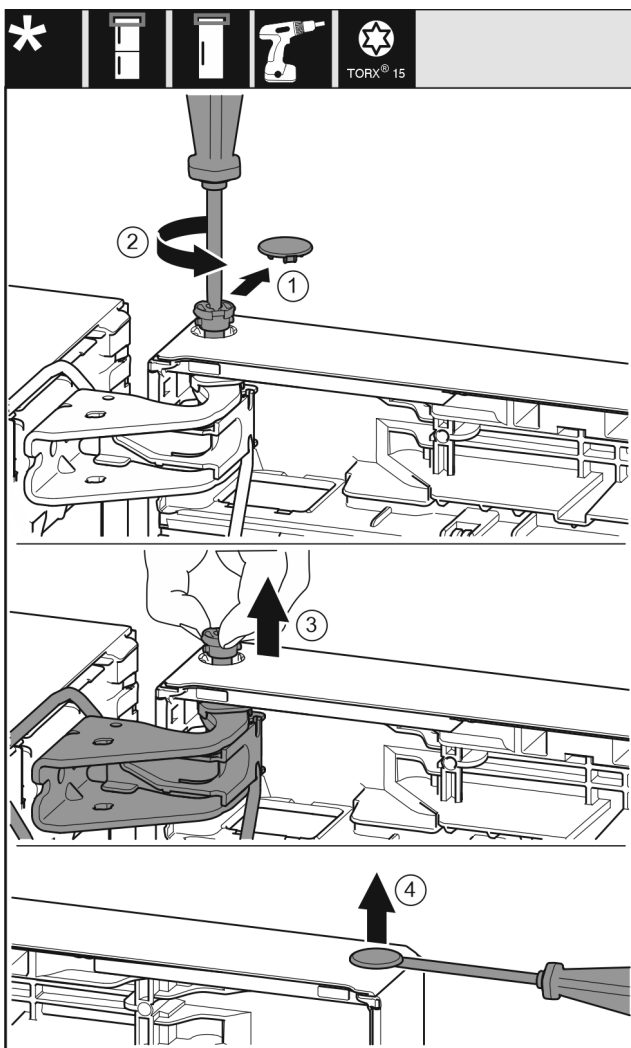

Fig. 21

- ▶ Carefully remove the cover (1).
- ▶ Use screwdriver to loosen the bolts (2) a little.



CAUTION

Danger of injury due to door tipping out!
If you remove the bolt on the door completely, the door may tilt out and you may injure yourself.

- ▶ Hold the door firmly before removing the bolt.
- ▶ Hold door in place.

- ▶ Pull out the bolt (3) with your fingers.
- ▶ Lift the door and put it to one side.
- ▶ Carefully lift and remove the cover (4) with a screwdriver.

3.8.5 Removing the lower door



CAUTION

Danger of injury due to door tipping out!
If you remove the bolt on the door completely, the door may tilt out and you may injure yourself.

- ▶ Hold the door firmly before removing the bolt.

-or-

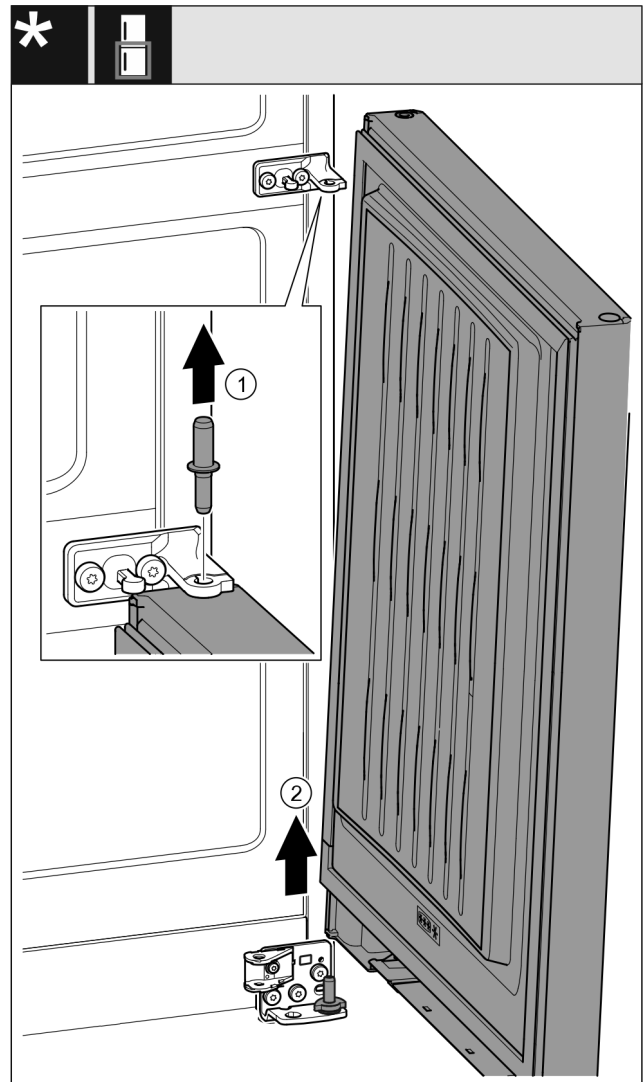

Fig. 22 With closing damper*

- ▶ Pull out the bolt Fig. 22 (1) upwards.*
- ▶ Swing out the door Fig. 22 (2), pull it upwards and set it aside.*

Setting up and connecting

3.8.6 Relocating the upper bearing components

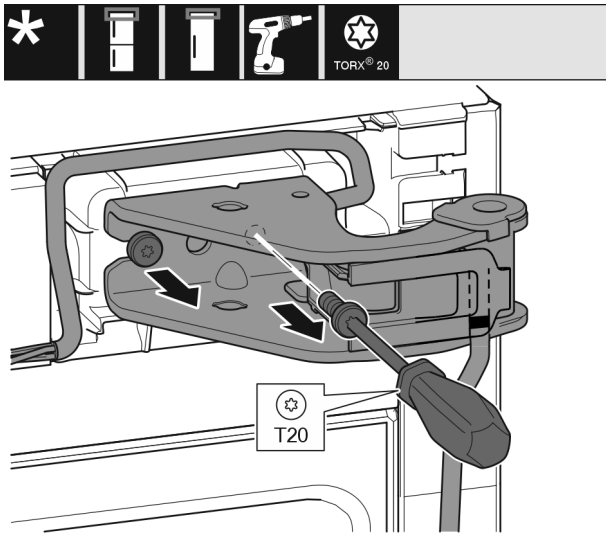

Fig. 23

- ▶ Unscrew both screws.
- ▶ Lift and remove the swap bearing block and the cable.

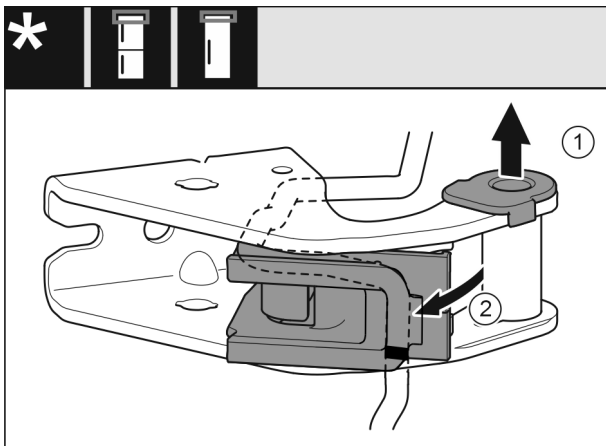

Fig. 24

- ▶ Pull the bearing bush (1) out of the guide.
- ▶ Swivel out the cable holder (2).

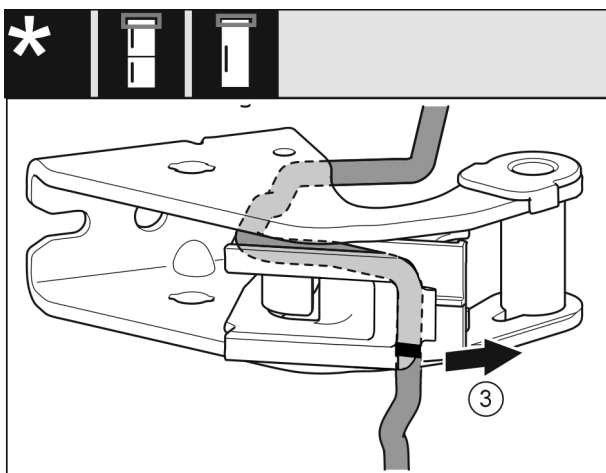

Fig. 25

- ▶ Remove the cable with the cable holder (3) from the swap bearing block.

NOTICE

Risk of damage due to incorrect cable routing!
If you do not lay the cable in accordance with the instructions, the cable may be crushed.

- ▶ Observe the markings on the cable.

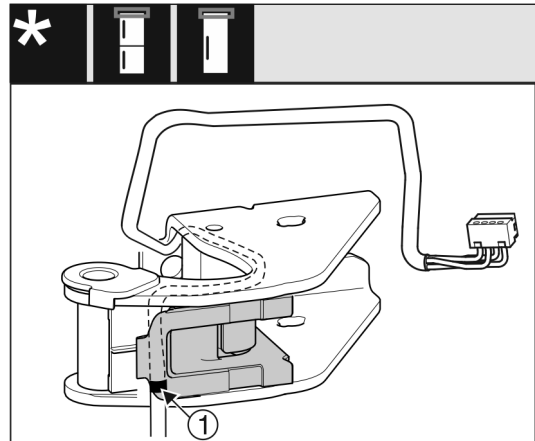

Fig. 26

- ▶ Insert the cable into the top groove in the cable holder inversely.
- ▶ Place the centre mark (1) on the cable on the edge of the cable holder.
- ▶ Swivel the cable holder in.

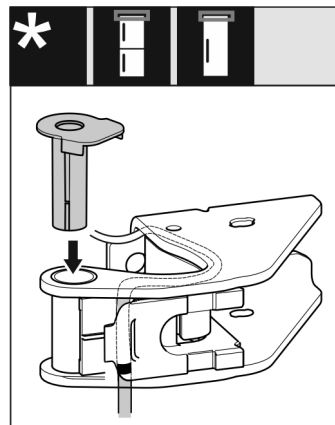

Fig. 27

- ▶ Insert the bearing bush from the other side and engage.



WARNING

Danger of injury due to door falling out!
If the bearing parts are not screwed on tightly enough, the door may fall out. This can result in serious injuries. In addition, the door may not close with the result that the appliance does not cool properly.

- ▶ Screw on the bearing brackets/bearing pins tightly with 4 Nm.
- ▶ Check all screws and retighten them if necessary.

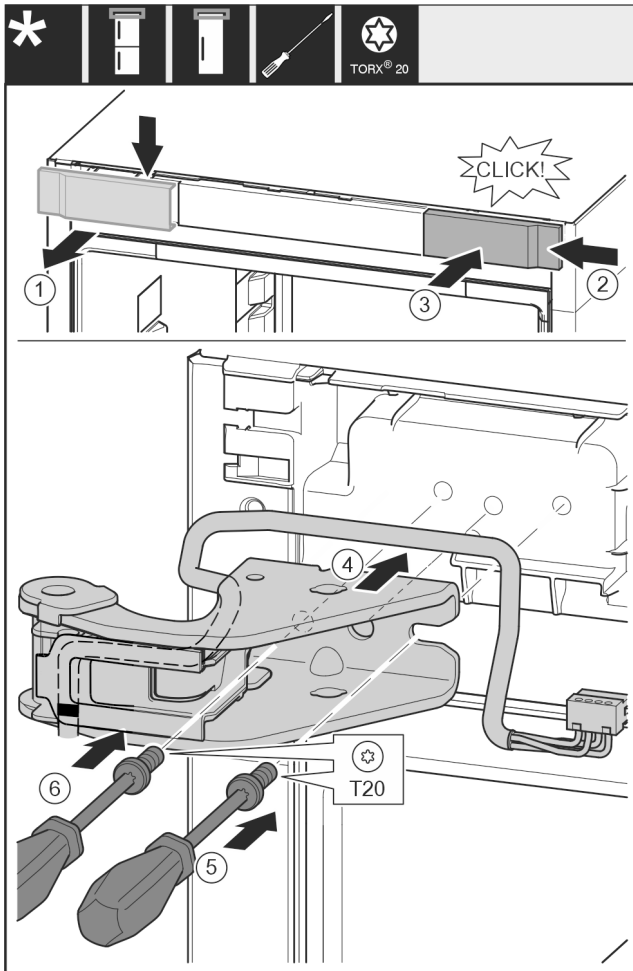

Fig. 28

- ▶ Remove the cover (1) from above towards the front.
- ▶ Turn the cover (2) by 180° and attach to the other side from the right.
- ▶ Engage the cover (3).
- ▶ Attach upper swap bearing block (4) with cable.
- ▶ Screw the screw (5) tight.
- ▶ Screw the screw (6) tight.

3.8.7 Moving the central bearing parts to the other side

WARNING

Danger of injury due to door falling out!
If the bearing parts are not screwed on tightly enough, the door may fall out. This can result in serious injuries. In addition, the door may not close with the result that the appliance does not cool properly.

- ▶ Screw on the bearing brackets/bearing pins tightly with 4 Nm.
- ▶ Check all screws and retighten them if necessary.

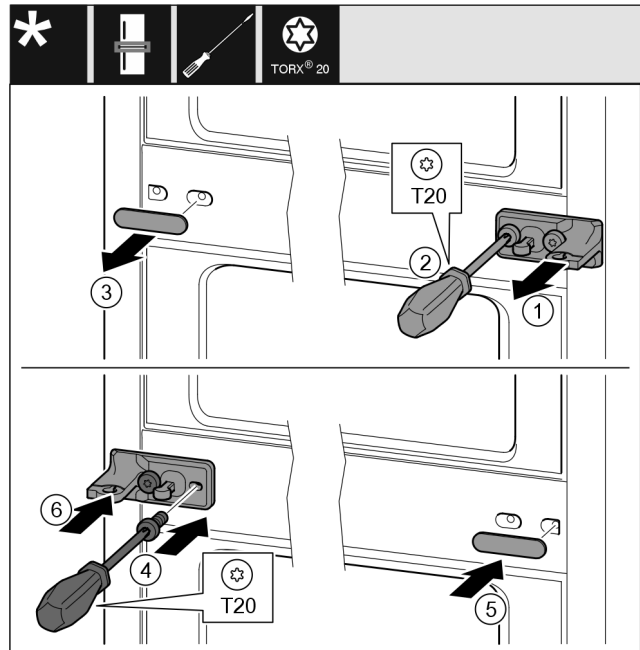

Fig. 29

- ▶ Remove the washer Fig. 29 (1).
- ▶ Unscrew screws Fig. 29 (2) with screwdriver.
- ▶ Remove the cover Fig. 29 (3) carefully.
- ▶ Turn the bearing block with film Fig. 29 (4) by 180° and screw it tight on the other side.
- ▶ Turn the cover Fig. 29 (5) by 180° and attach to the other side.
- ▶ Slide on the washer Fig. 29 (6) from the front.

3.8.8 Moving the lower bearing parts to the other side

For all appliances:

WARNING

Danger of injury due to door falling out!
If the bearing parts are not screwed on tightly enough, the door may fall out. This can result in serious injuries. In addition, the door may not close with the result that the appliance does not cool properly.

- ▶ Screw on the bearing brackets/bearing pins tightly with 4 Nm.
- ▶ Check all screws and retighten them if necessary.

Setting up and connecting

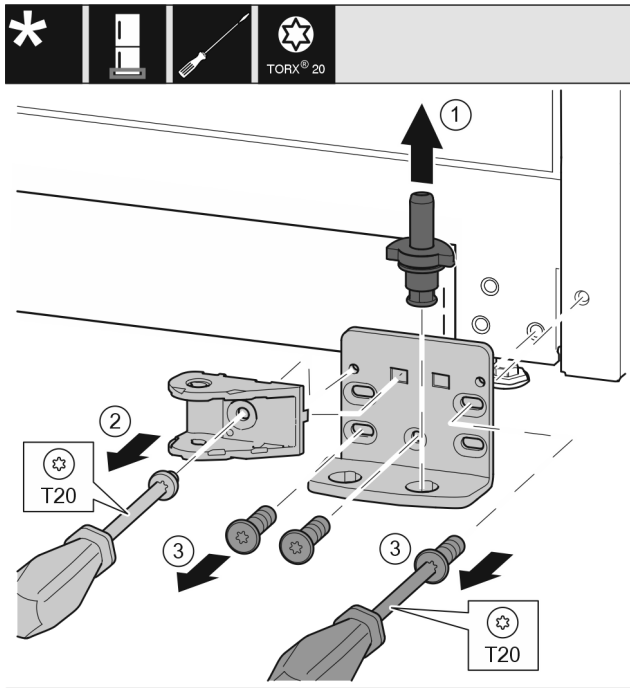

Fig. 30

- ▶ Pull the bearing bolt Fig. 30 (1) out upwards completely.
- ▶ Use screwdriver to unscrew the screw Fig. 30 (2) and remove the closing damper connection.
- ▶ Use screwdriver to unscrew the screws Fig. 30 (3) and remove the swap bearing block.

For all appliances:

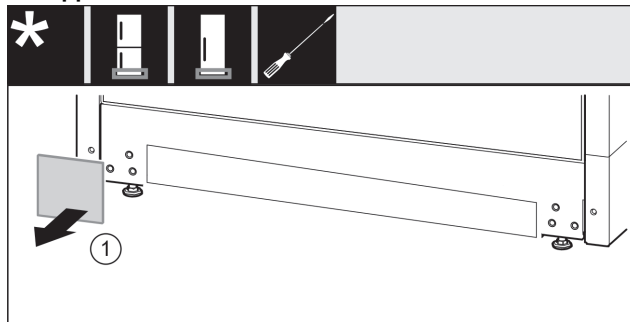

Fig. 31

- ▶ Remove cover Fig. 31 (1).

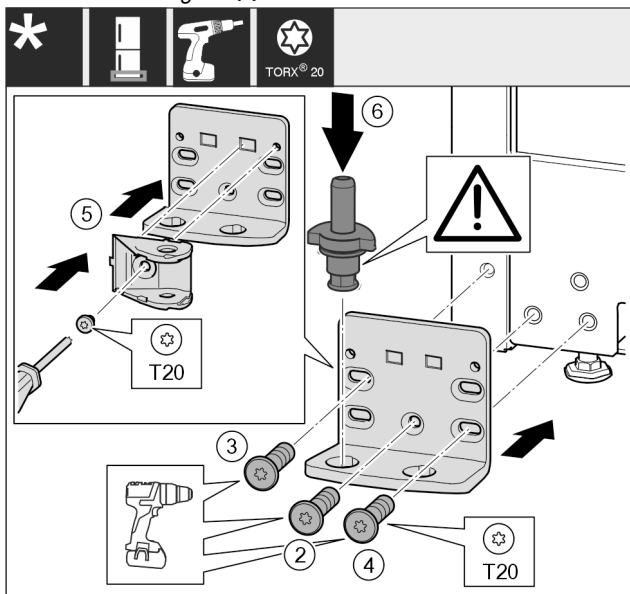

Fig. 32

- ▶ Place the swap bearing block on the other side and use a screwdriver to screw it on. Start with the screw Fig. 32 (2) at the bottom in the middle.
- ▶ Tighten screw Fig. 32 (3) and screw Fig. 32 (4).
- ▶ Turn the closing damper connection Fig. 32 (5) by 180°. Use screwdriver to screw it onto the other side of the swap bearing block.
- ▶ Insert the bearing bolt Fig. 32 (6) completely. Ensure that the latching cam is pointing towards the rear.

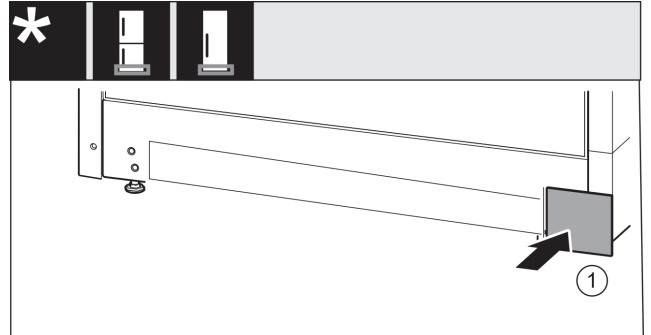

Fig. 33

- ▶ Re-attach the cover Fig. 33 (1) to the other side.

3.8.9 Moving the door bearing parts to the other side

Top of door

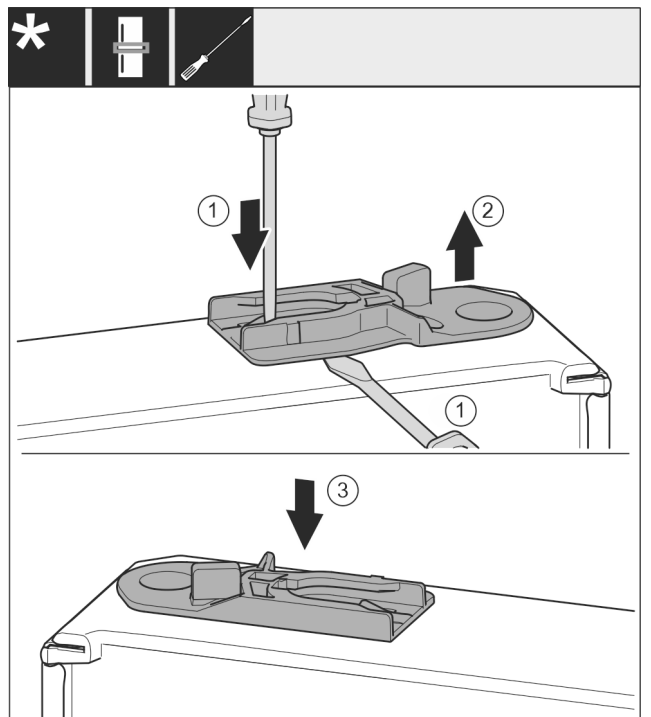

Fig. 34

- ▶ The bottom side of door faces upwards: Turn the door.
- ▶ Appliances with closing damper: Pull out the guide bush: Press the tab Fig. 34 (1) with a flat-blade screwdriver and at the same time move the flat-blade screwdriver under the guide bush Fig. 34 (2).
- ▶ Appliances with closing damper: Insert the guide bush Fig. 34 (3) supplied on the other side of the housing.
- ▶ The upper side of door faces upwards: Turn the door.

3.8.10 With closing damper: Fitting the lower door

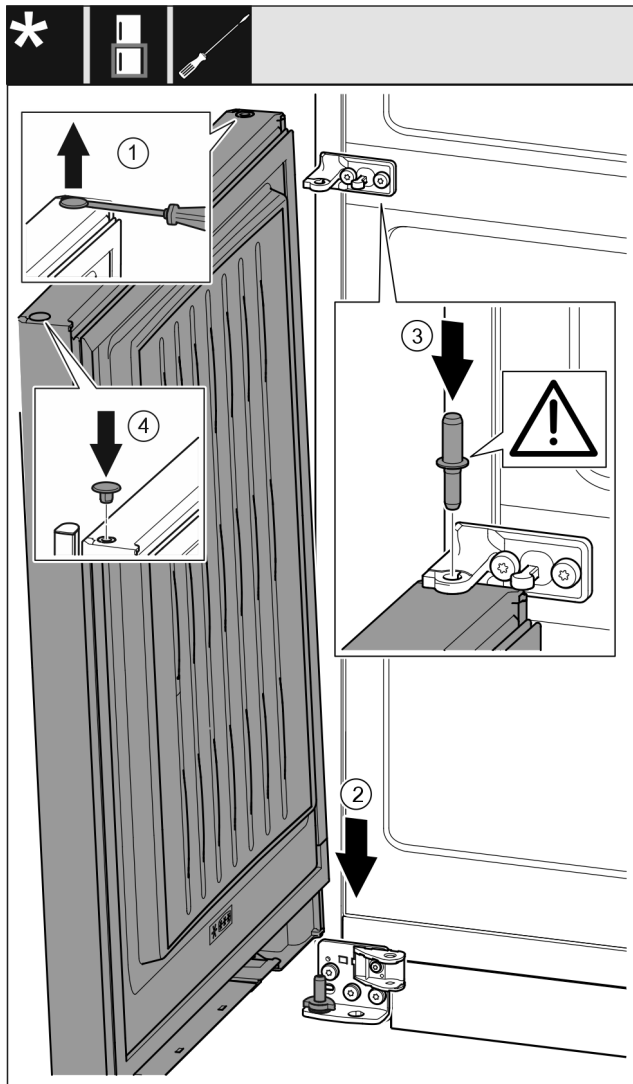

Fig. 35

- ▶ Use a slotted screwdriver to lift the plug Fig. 35 (1) carefully and pull it out.
- ▶ Lower the door Fig. 35 (2) onto the bottom bearing bolt.
- ▶ Insert the centre bearing bolt Fig. 35 (3) through the centre bearing block in the lower door. Ensure that the latching cam is pointing towards the rear.
- ▶ Re-insert the plug Fig. 35 (4) on the other door side.

3.8.11 Fitting the upper door

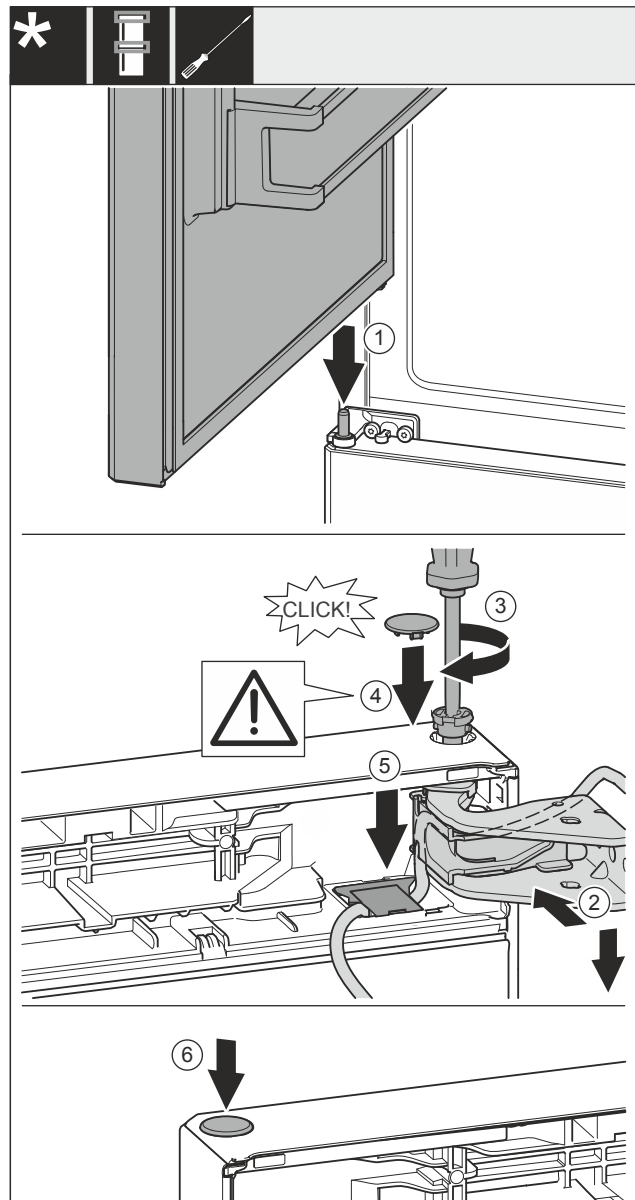

Fig. 36

- ▶ Place the top door on the centre bearing bolt Fig. 36 (1).
- ▶ Align the top door with the opening in the swap bearing block Fig. 36 (2).
- ▶ Insert the bolt Fig. 36 (3) and use screwdriver to tighten it.
- ▶ Insert the cover Fig. 36 (4).
- ▶ Check that the cover Fig. 36 (4) is resting on the door.
- ▶ Insert the cover Fig. 36 (5) and push down until it engages.
- ▶ Insert the cover Fig. 36 (6).

Setting up and connecting

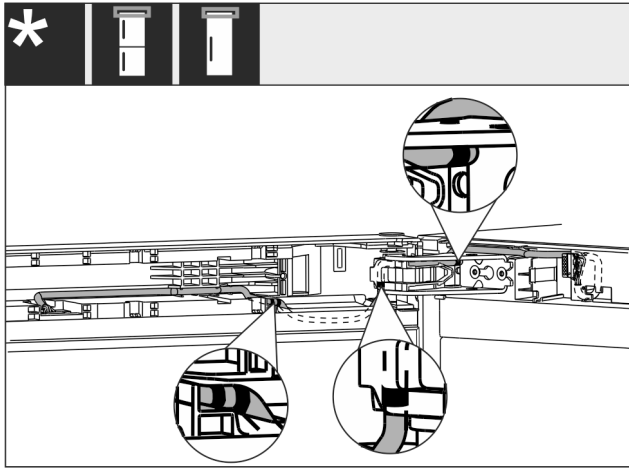

Fig. 37

- ▶ Lay the cable end with double marking in the door end piece.
- ▶ Cable routing is as shown in figure Fig. 37 ().

3.8.12 Fitting the cable connection

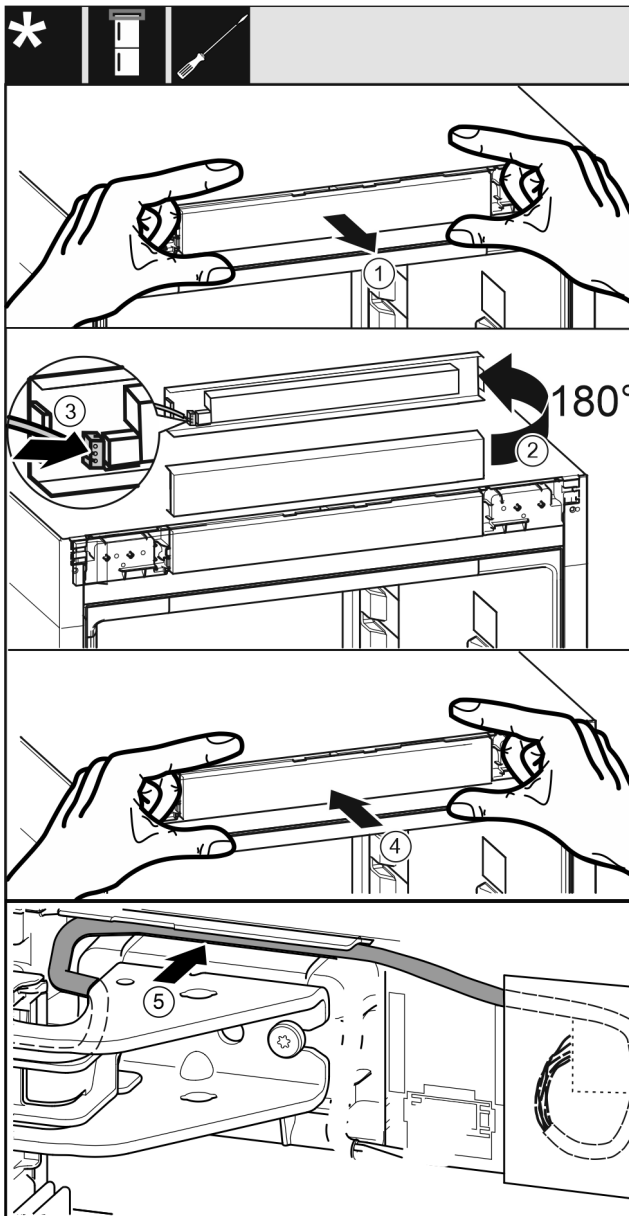

Fig. 38

- ▶ Remove the control panel trim Fig. 38 (1) carefully.

- ▶ Turn the control panel trim Fig. 38 (2) up by 180°.
- ▶ Engage the plug Fig. 38 (3) on the control panel trim.
- ▶ Re-engage the control panel trim Fig. 38 (4) on the appliance.
- ▶ Lay the cable Fig. 38 (5) carefully in the guide above the top swap bearing block.

-or-

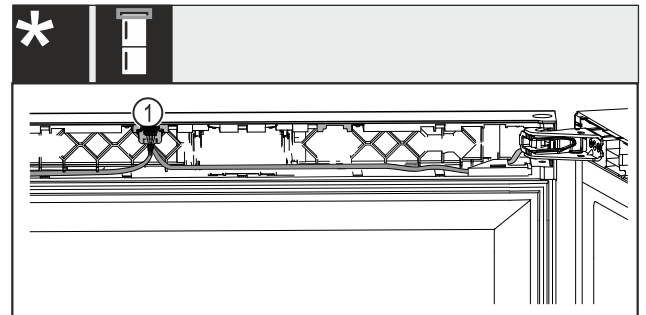

Fig. 39 Wine-freezer combinations

- ▶ Insert both cables into the top door.
- ▶ Snap the plug Fig. 39 (1) into the guide.
- For all appliances:
- ▶ Position the remaining cable length as a loop in the guide, if required.

3.8.13 Aligning the doors

For all appliances:



WARNING

Danger of injury due to door falling out!

If the bearing parts are not screwed on tightly enough, the door may fall out. This can result in serious injuries. In addition, the door may not close with the result that the appliance does not cool properly.

- ▶ Screw the bearing brackets on firmly with 4 Nm.
 - ▶ Check all screws and retighten them if necessary.
-
- ▶ Align the doors flush with the appliance housing using the two slots in the lower bearing bracket and centre bearing bracket if needed. To do this undo the middle screw in the bottom bearing bracket with the T20 tool supplied. Undo the remaining screws a little with the T20 tool or with a T20 screwdriver and align using the slotted holes. Undo the screws in the middle bearing bracket with the T20 tool and align the middle bearing bracket using the slotted holes.
 - ▶ Prop up the door: Take off the adjustable foot on the bearing bracket using the open-ended wrench SW10 until it comes into contact with the floor, then turn an additional 90°.

3.8.14 Appliances with closing damper: Fitting the lower closing damper

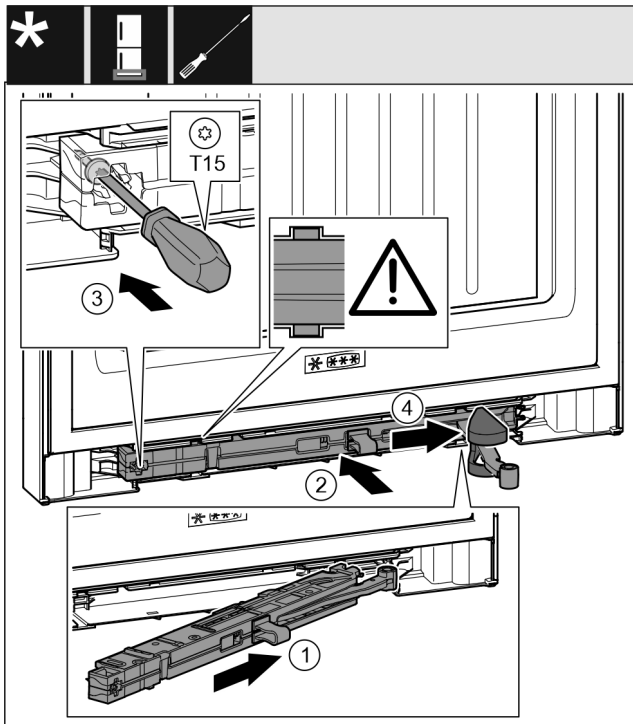

Fig. 40

- ▶ On the swap bearing block side, slide the closing damper unit Fig. 40 (1) into the recess at an angle up to the stop.
- ▶ Push the closing damper unit Fig. 40 (2) into the recess completely.
- ▶ The closing damper unit is positioned correctly if the closing damper unit's rib is in the guide.
- ▶ Use a screwdriver to tighten the screw Fig. 40 (3).
- ▶ Push the cover Fig. 40 (4) over the joint.

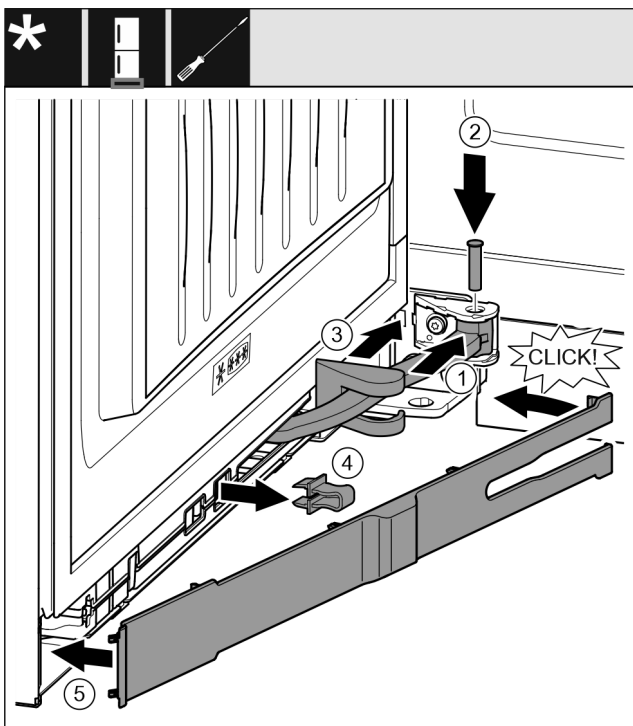

Fig. 41

The door is open 90°

- ▶ Turn the joint Fig. 41 (1) in the attachment.

- ▶ Use a screwdriver to insert the bolt Fig. 41 (2) into the attachment and the joint. Ensure that the latching cam is in the groove properly.
- ▶ Push the swap bearing block cover Fig. 41 (3) along the joint and use the attachment to fit it.
- ▶ Remove the safeguard Fig. 41 (4).
- ▶ Place the trim Fig. 41 (5) on the handle side and swing in.
- ▶ The panel is latched into place.
- ▶ Close the bottom door.

3.8.15 Appliances with closing damper: Fitting the upper closing damper

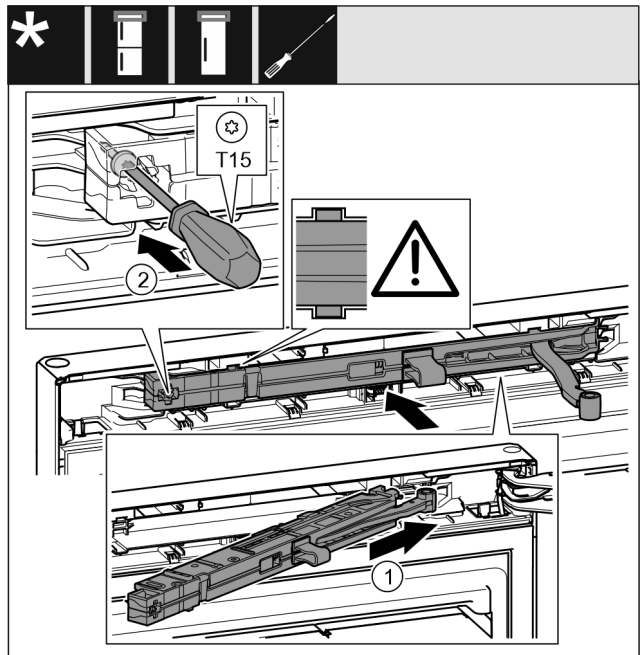

Fig. 42

- ▶ On the swap bearing block side, slide the closing damper unit Fig. 42 (1) into the recess at an angle up to the stop.
- ▶ Push the closing damper unit completely in.
- ▶ The closing damper unit is positioned correctly if the closing damper unit's rib is in the guide in the housing.
- ▶ Use a screwdriver to tighten the screw Fig. 42 (2).

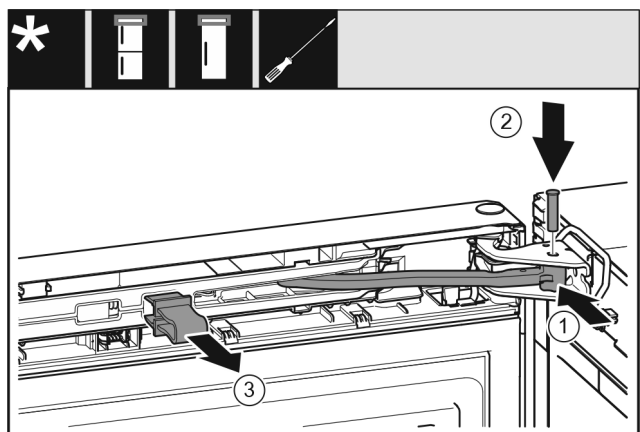

Fig. 43

The door is open 90°.

- ▶ Turn the joint Fig. 43 (1) in the bearing block.
- ▶ Insert the bolt Fig. 43 (2) into the bearing bracket and joint. Ensure that the latching cam is in the groove properly.
- ▶ Remove the safeguard Fig. 43 (3).

Setting up and connecting

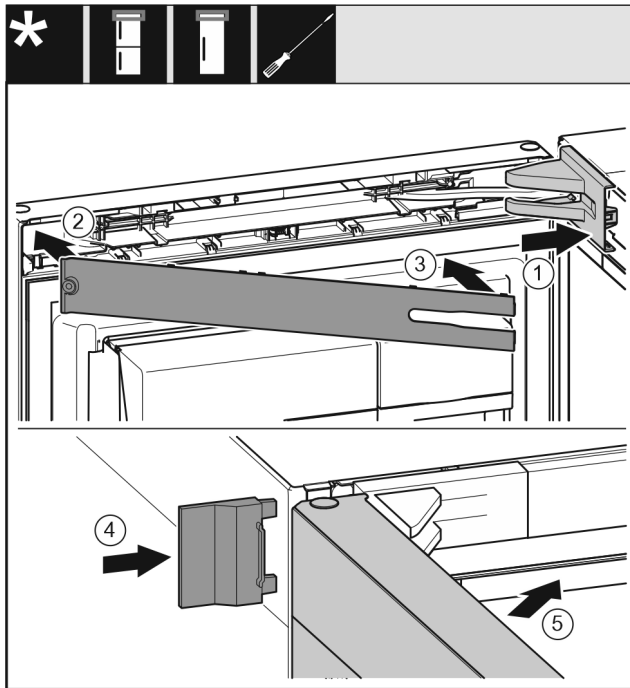

Fig. 44

- ▶ Put the swap bearing block cover Fig. 44 (1) on and engage, push apart carefully if required.
- ▶ Fit the trim Fig. 44 (2).
- ▶ Swivel in the cover Fig. 44 (3) and engage.
- ▶ Push the outer cover Fig. 44 (4) on.
- ▶ Close the upper door Fig. 44 (5).

3.9 Connecting the appliance to the water supply

Make sure that the following requirements are fulfilled:

- ❑ The dimensions for the water supply connection are known and complied with.
- ❑ The correct water pressure is maintained.
- ❑ Water is supplied to the appliance via a cold water pipe which can withstand the operating pressure and is connected to the drinking water supply.
- ❑ All equipment and devices used to supply water must comply with the regulations in force in the respective country.
- ❑ The rear of appliance is accessible so that you can connect the appliance to the drinking water supply.
- ❑ The supplied hose is used. Old hoses have been disposed of.
- ❑ The hose connector contains a filter with a seal.
- ❑ There is a tap between the hose line and the domestic water connection so that you can turn off the water supply if necessary.
- ❑ The tap is not directly behind the appliance and is easily accessible. This way, you can push the appliance as close as possible to the wall and can quickly turn off the tap if necessary.
- ❑ A coupler between the R3/4 connection thread and the 1/4" OD copper pipe is supplied.
- ❑ There is a screen filter with a seal in the coupler. The screen filter with a seal is supplied.
- ❑ A **1/4" OD copper pipe** is used to connect the water supply to the solenoid valve. **This is not included.**

- ❑ There is an adaptor between the hose 1/4" OD copper pipe and the domestic water connection so that you can turn off the water supply if necessary.
- ❑ The adaptor is not directly behind the appliance and is easily accessible. This way, you can push the appliance as close as possible to the wall and can quickly turn off the tap if necessary.



WARNING

Risk of electric shock from water!

- ▶ Before connecting to the water pipe: Disconnect the appliance from the mains.
- ▶ Before connecting to water supply lines: Shut off the water supply.
- ▶ Make sure that only qualified personnel connect the device to the drinking water supply.



WARNING

Risk of poisoning due to contaminated water!

- ▶ Only connect to the drinking water supply.

3.9.1 Connecting the hose

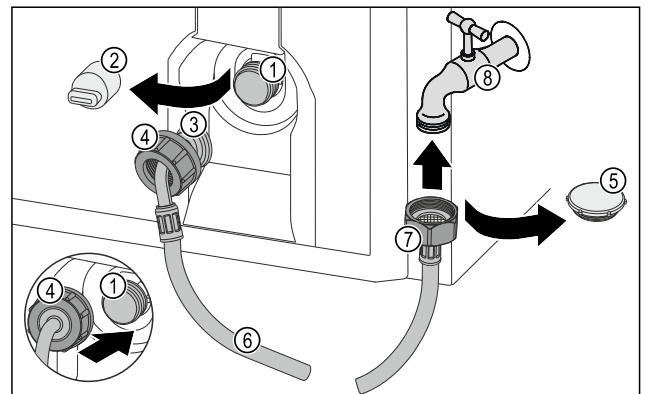

Fig. 45

- | | |
|--|-----------------------|
| (1) Solenoid valve: The solenoid valve is located at the bottom rear of the appliance. It has an R3/4 connection thread. | (5) Closure cap |
| (2) Cover | (6) Hose |
| (3) Angled hose end | (7) Straight hose end |
| (4) Nut | (8) Tap |

NOTICE

Risk of damage from incorrect installation!

- ▶ Do not damage or kink the hose.
- ▶ Do not damage or kink the hose when setting up the appliance.

Connecting the hose to the appliance:

- ▶ Pull off the cover (2).
- ▶ Push and hold the nut (4) all the way over the angled hose end (3).

NOTICE

The solenoid valve will not be tight if the thread is damaged! If the solenoid valve is not tight, water may leak out.

- ▶ Observe the following instructions for fitting the nut on the solenoid valve.

- ▶ Carefully position and hold the nut (4) on the solenoid valve (1).
- ▶ Screw the nut (4) by hand straight onto the thread until it is securely and firmly seated.

- ▶ The hose is connected to the appliance.

Connecting the hose to the tap:

- ▶ Remove the closure cap *Fig. 45 (5)*.
- ▶ Place the straight end of the hose *Fig. 45 (7)* on the tap *Fig. 45 (8)*.
- ▶ Tighten the nut at the straight end of the hose *Fig. 45 (7)* in a clockwise direction.
- ▶ The hose is connected to the tap.

3.9.2 Checking the water system

Before you completely install the appliance, Liebherr recommends checking the water system for leaks.

- ▶ Slowly turn on the tap.
- ▶ Check the hose, water feed and connections for leaks.
- ▶ The water system has now been checked for leaks.
- ▶ The water system is not leaking: You can install up the appliance completely.

Note

IceMaker: Before the first use, you must clean the IceMaker. (see Quick Start Guide or operating instructions)

3.10 Mounting wall spacers*

With wall spacers, your device achieves the declared energy consumption and no condensation forms in high ambient humidity. The device is fully functional without the spacer brackets, but its energy consumption will be slightly higher. If you insert the wall spacers, then the device depth increases by approx. 15 mm.*

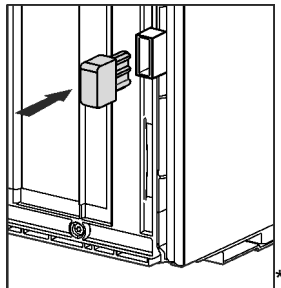

- ▶ Appliance with enclosed wall spacers: Insert the wall spacers on the rear of the appliance at the bottom left and right.

3.11 Setting up the appliance



CAUTION

Risk of injury due to heavy appliance!

- ▶ Have two people transport the appliance to its installation site.



CAUTION

Risk of injury and damage!*

The door may strike the wall and be damaged as a result. In the case of glass doors, the damaged glass may cause injuries!

- ▶ Protect the glass door from striking against the wall. Fit a door stop, e.g. one made of felt, to the wall.
- ▶ A limiter restricting door opening to 90° can be ordered from the aftersales service.



WARNING

Risk of fire due to short circuit!

- ▶ When you set the appliance up: do not kink, jam or damage the mains cable.
- ▶ The appliance must not be operated with a defective mains cable.



WARNING

Fire hazard and danger of damage!

- ▶ Do not place appliances emitting heat e.g. microwaves, toasters etc. on the appliance!

Ensure that the following conditions are met:

- Only move the device when it is not loaded.
- Only install the appliance with help.
- ▶ Remove the mains cable from the package.
- ▶ Plug the mains cable's IEC socket completely into the appliance plug on the back of the appliance. Ensure that the IEC socket is tight.
- ▶ Use a cord to lay the mains plug to a freely accessible socket if required.

3.12 Setting up the appliance so that it is level

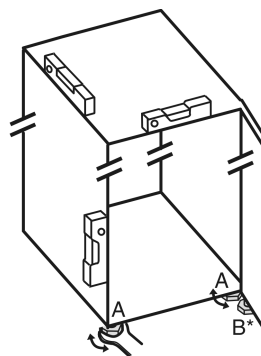

Fig. 46

- ▶ Unscrew the adjustable feet *Fig. 46 (A)* using the enclosed open-end spanner and a spirit level until the appliance is firmly aligned and level.



CAUTION

Risk of injury and damage due to the appliance tipping over! If the additional adjustable foot on the lower swap bearing block does not rest properly on the floor, the appliance may tip over. This can lead to property damage and injuries.

- ▶ Unscrew the additional adjustable foot on the swap bearing block as instructed.
- ▶ Unscrew the adjustable foot *Fig. 46 (B)* on the swap bearing block with the enclosed open-end spanner until it rests on the floor.
- ▶ Turn the adjustable foot *Fig. 46 (B)* 90° further.
- ▶ The appliance is aligned.

3.13 After setting up

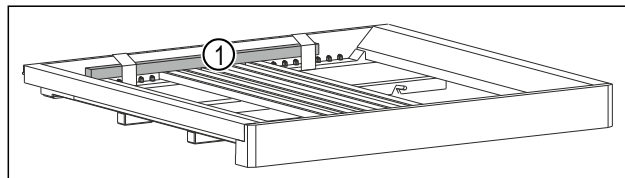

Setting up and connecting

Fig. 47 *

- ▶ Remove the wooden stick Fig. 47 (1).*
- ▶ Remove all transport safety components.
- ▶ Take off the protective film from the exterior of the appliance.
- ▶ Take off the protective film from the trim panels.*
- ▶ Take off the protective film from the stainless steel rear panel.
- ▶ Clean the appliance. (see operating instructions)
- ▶ Note the type (model, number), appliance designation, appliance/serial number, purchase date and dealer's address.

3.14 Installing multiple appliances

The appliances have been developed for different installation methods. If you wish to install several appliances next to each other or on top of each other, ensure that the following requirements are met:

- Only install appliances next to or on top of each other if they have been developed for this.
- Observe notices and the following table.

NOTICE

Risk of damage due to condensate!

- ▶ Do not place the appliance directly next to another cooling/refrigeration unit.

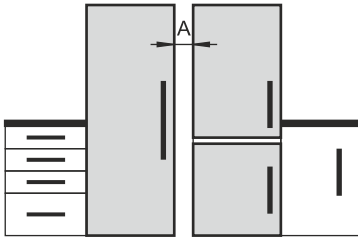
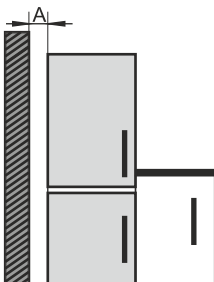
Model	Installation method
All models	Standalone
Models with a model designation starting with S...	Side-by-Side (SBS)
Models without side wall heating	 <p>Next to each other: Install with gap A of 70 mm between the appliances. If you do not comply with this gap, condensation will form on the side walls between the appliances.</p>  <p>On an exterior wall: Install with gap A as with installation next to each other. If you do not comply with this gap, condensation may form on the appliance's side wall.</p>

Models and their installation method

Assemble the appliances according to the separate installation instructions.

3.15 Integrating the appliance into a kitchen unit

The appliance can be integrated into a kitchen unit. Please observe the following installation conditions:

- If you fit a stacking cabinet above the appliance, you must allow for a ventilation cross-section with the appropriate depth at the rear of the stacking cabinet.
- If you place the appliance with the hinges next to a wall, you must take the distance to the side of the appliance into account.
- To ensure that the door can be opened fully, the appliance must protrude beyond the front thickness. Depending on the niche depth, the appliance may protrude further.

Note

A set for limiting the door opening angle to 90° can be obtained from customer service for appliances with soft closing.



WARNING

Risk of fire due to short circuit!

- ▶ When you set the appliance up: do not kink, jam or damage the mains cable.
- ▶ The appliance must not be operated with a defective mains cable.

Ensure that the following requirements are met:

- The socket is easily accessible and is not behind the appliance.
- Ventilation requirements are met. (see 3.3 Ventilation requirements) .
- Connection dimensions are taken into account. (see 3.17 Connecting the appliance to the power supply)
- Wall spacers are fitted.*

3.15.1 Niche dimensions for appliances with recessed handles

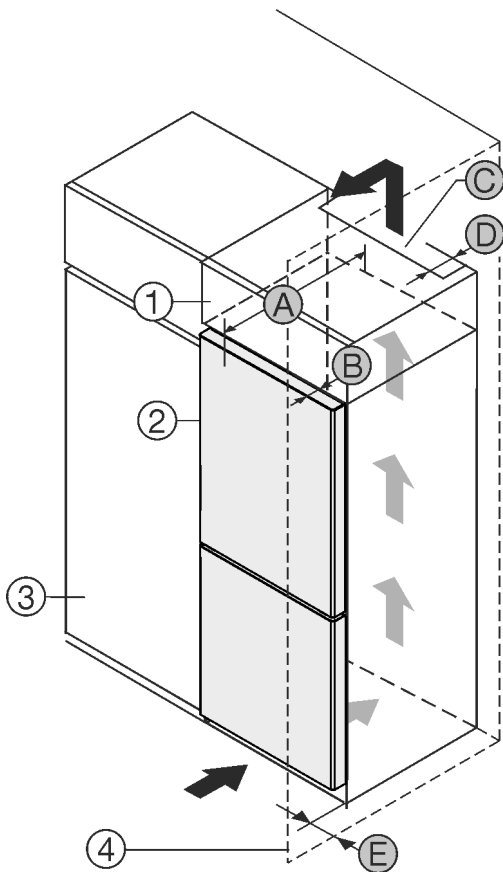

Fig. 48

- (1) Top Unit
- (2) Appliance
- (3) Kitchen cupboard
- (4) Wall
- (A) Appliance depth
- (B) Door depth
- (C) Ventilation cross-section
- (D) Distance from rear of the appliance
- (E) Distance to the side of the appliance

Appliances with a recessed grip:	
A	675 mm ^x
B	75 mm
C	min. 300 cm ²
D	min. 50 mm
E	min. 13 mm

Appliances with recessed handle and glass front / stone front:	
A	682 mm ^x
B	82 mm
C	min. 300 cm ²
D	min. 50 mm
E	min. 20 mm

^x On devices with wall spacer brackets, this dimension increases by 15 mm.*

3.16 Disposing of packaging



WARNING

Danger of suffocation due to packing material and plastic film!

- ▶ Do not allow children to play with packing material.

The packaging is made of recyclable materials:

- corrugated board/cardboard
 - expanded polystyrene parts
 - polythene bags and sheets
 - polypropylene straps
 - nailed wooden frame with polyethylene panel*
- ▶ Take the packaging material to an official collecting point.

3.17 Connecting the appliance to the power supply



WARNING

Danger of electric shock and injury due to damaged appliance or damaged mains cable!
 Danger of cuts and fatal injuries. If the appliance or the mains cable is damaged during transport, you may be electrocuted. You could also cut yourself on damaged parts of the appliance housing.

- ▶ Check the appliance and the mains cable for damage after transport.
- ▶ Never put the appliance into operation if the appliance or the mains cable are damaged.
- ▶ Contact Customer Service.

You can connect your appliance to the mains using the power cable supplied separately. The mains power cable has an appliance coupler at one end and a mains plug at the other end.

Make sure that the following requirements are fulfilled:

- The appliance and power cable are undamaged.
- The appliance is set up in accordance with the regulations. (see 3.10 Mounting wall spacers*)
- Requirements for the electrical connection are met.
- Dimensions for connection in accordance with regulations are known and observed. (see 3.4 Connection dimensions for the power supply)
- Mains voltage and frequency correspond to the specifications on the type plate.
- The socket is earthed according to the regulations and fused.
- The fuse tripping current is between 10 A and 16 A.
- The socket is easily accessible and is not behind the appliance. (see 3.4 Connection dimensions for the power supply)

NOTICE

Danger of damage to incorrect operation!
 Damage to the electrical components of the appliance.

- ▶ Only use the supplied mains cable.



WARNING

Danger of fire due to incorrect connection!
 Burns.

Damage to the appliance.

- ▶ Do not use an extension cable.
- ▶ Do not use distributor blocks.

Functionality of the Touch & Swipe display

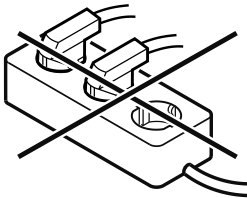

NOTICE

Danger of damage to incorrect connection!

Damage to the appliance.

▶ Do not connect the appliance to a stand-alone inverter, e.g. solar power systems and petrol generators.

- ▶ Connect the mains cable plug to the power supply. Ensure that the plug is tightly in the socket.
- ▶ The Liebherr logo appears in the display.
- ▶ The display switches to the standby symbol.
- ▶ If no action occurs within 60 seconds: The standby symbol fades or disappears.
- ▶ The appliance is connected. For information regarding first use, see the following section or the operating instructions.

4 Functionality of the Touch & Swipe display

You operate your appliance using the Touch & Swipe display. You select appliance functions in the Touch & Swipe display (hereafter referred to as display) by tapping them. If you do not perform any action on the display for 10 seconds, the display either jumps back to the higher-level menu or directly to the status display.

4.1 Navigation and symbol explanation

In the illustrations, different symbols are used to navigate the display. The following table describes these symbols.

Symbol	Description
	Briefly touch the display: Activates/deactivates function. Confirms selection. Opens submenu.
	Touch the display for a specified time (e.g. 3 seconds): Activates/deactivates function or value.
	Swipe left or right: Navigate in the menu.
	Briefly touch the Back symbol: Jumps back one menu level.
	Press and hold the Back symbol for 3 seconds: Jumps back to the status display.

Symbol	Description
	Arrow with clock: It takes more than 10 seconds for the following message to appear in the display.
	Arrow with a time indication: It takes the specified amount of time until the following message appears in the display.
	“Open Settings menu” symbol: Navigates to the Settings menu and opens the settings menu. If necessary: Navigate to the desired function in the Settings menu. (see 4.2.1 Opening the Settings menu)
	“Open Advanced menu” symbol: Navigates to the Advanced menu and opens the advanced menu. If necessary: Navigate to the desired function in the Advanced menu. (see 4.2.2 Opening the expanded menu)
No action for 10 seconds	If you do not perform any action on the display for 10 seconds, the display either jumps back to the higher-level menu or directly to the status display.
Close the door and open it again.	If you close the door and immediately open it again, the display jumps directly back to the status display.

Note: Illustrations of the display are shown in the English version.

4.2 Menus

The appliance functions are distributed over various menus:

Menu	Description
Main menu	When you switch the appliance on, you are automatically in the main menu. From here you can navigate to the most important appliance functions, to the Settings menu and to the Advanced menu.
 Settings menu	The Settings menu contains additional appliance functions for setting up your appliance.
Advanced menu	The advanced menu contains special appliance functions for setting up your appliance. Access to the Advanced menu is protected by the numerical code 1 5 1 .

4.2.1 Opening the Settings menu

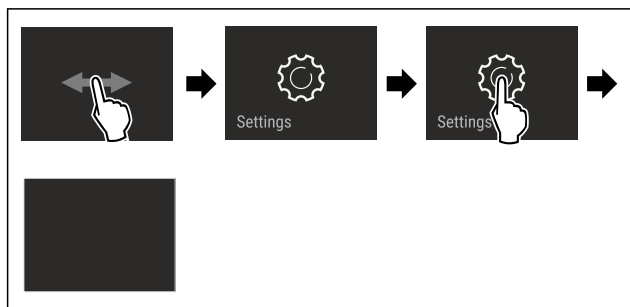

Fig. 49 Example illustration

- ▶ Carry out action steps according to the illustration.
- ▶ Settings menu is open.
- ▶ If necessary: Navigate to the desired function.

4.2.2 Opening the expanded menu

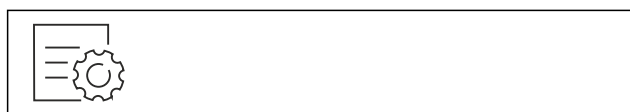

Fig. 50

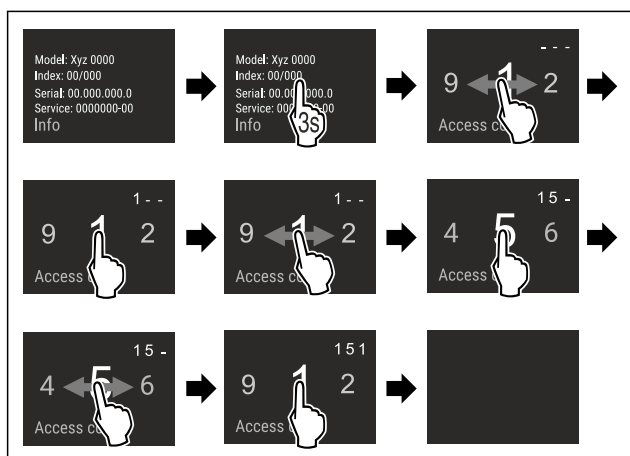

Fig. 51 Example illustration, access with numerical code 151

- ▶ Carry out action steps according to the illustration.
- ▶ The expanded menu is open.
- ▶ If necessary: Navigate to the desired function.

4.3 Sleep mode

If you do not touch the display for 1 minute, the display switches to sleep mode. In sleep mode, the display brightness is dimmed.

4.3.1 Ending sleep mode

- ▶ Touch the display briefly with your finger.
- ▶ Sleep mode is ended.

5 Putting into operation

5.1 Switching on appliance (first use)

Make sure that the following requirements are fulfilled:

- The appliance has been installed and connected in accordance with the installation instructions.
- All adhesive strips, adhesive and protective films and transport locks are removed from inside and on the appliance.

- All marketing leaflets are removed from the drawers.
- You are familiar with the functionality of the Touch & Swipe display. (see 4 Functionality of the Touch & Swipe display)

Switch on the appliance using the Touch & Swipe display:

- ▶ If the display is in sleep mode: Briefly touch the display.
- ▶ Carry out action steps according to the illustration.

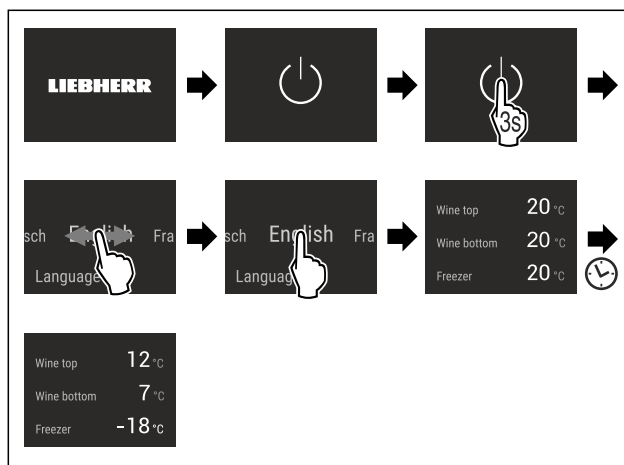

Fig. 52 Example illustration

- ▶ Status display appears.
- ▶ The appliance cools to the temperature set at the factory.
- ▶ The appliance starts in demo mode (status display with DEMO appears): If the appliance starts in demo mode, you can deactivate demo mode within the next 5 minutes. (see Demo mode)

More information:

- Start the IceMaker for the first time. (see 5.2 Starting the IceMaker for the first time)
- Start the SmartDevice for the first time. (see 2.3 Smart-Device) and (see WiFi)

Note

The manufacturer recommends:

- ▶ **Store frozen foods** at -18 °C or colder.
- ▶ Observe the notes on storing food. (see 6.1 Information regarding storage)

Note

Accessories can be purchased from the Liebherr-Hausgeräte store at home.liebherr.com/shop/de/deu/zubehor.html.

5.2 Starting the IceMaker for the first time

If your appliance is equipped with IceMaker, you must clean the IceMaker **before using it for the first time**.

Make sure that the following requirements are fulfilled:

- The water supply has been connected. See Installation Guide or mounting instructions.
- The appliance is properly connected.
- ▶ Clean the IceMaker. (see 10.4.5 Cleaning the IceMaker)

6 Storage

6.1 Information regarding storage



WARNING

Fire hazard from electrical appliances!

If you use electrical appliances in the food area of your appliance, they can cause a fire.

- ▶ Do not use electrical appliances in the food area of the appliance unless recommended by the manufacturer.

Note

The energy consumption increases and the cooling power goes down if ventilation is not sufficient.

- ▶ Always keep air slots clear.

Observe the following specifications for storage:

- In the freezer compartment: Package food properly.
- Package raw meat or fish in clean, closed containers. This will prevent meat or fish from touching or dripping onto other food.
- Keep liquids in closed containers.
- Leave space between goods to ensure good air circulation.
- In the wine compartment: Position storage shelves according to the height required.
- In the wine compartment: Observe maximum load weight. (see 11.1 Technical specifications)
- Store food according to the instructions on the packaging.
- Always observe the best-before date indicated on the packaging.

Note

Failure to follow these guidelines can lead to foodstuffs spoiling.

6.2 Freezer compartment

Here, a dry, frosty storage climate is created at -18 °C. A frosty storage climate is suitable for storing frozen food for several months, for making ice cubes or freezing fresh food.

6.2.1 Freezing food

Freezing quantity

The maximum amount of fresh food that you can freeze within 24 hours is specified on the type plate (see 11.5 Model plate) under "Freezing capacity ... kg/24h".

To ensure that food quickly freezes through, adhere to the following quantities per package:

- Fruit and vegetables up to 1 kg
- Meat up to 2.5 kg

Freezing food using SuperFrost

Depending on the quantity to be frozen, you can activate SuperFrost before freezing in order to achieve lower freezing temperatures. (see SuperFrost)

- ▶ Activate SuperFrost if the amount of food you have to freeze is more than approx. 2 kg.

The time at which you activate SuperFrost depends on the amount of food you have to freeze:

Freezing quantity	Time at which you should activate SuperFrost
Small amount of food to freeze	Activate SuperFrost about 6 hours before freezing. As soon as the appliance automatically deactivates SuperFrost, you can rearrange the food.
Maximum amount of food to freeze	Activate SuperFrost about 24 hours before freezing. As soon as the appliance automatically deactivates SuperFrost, you can rearrange the food.

Arranging your food properly



CAUTION

Risk of injury from broken glass!

Bottles and cans with beverages can burst during freezing. This applies in particular to carbonated beverages.

- ▶ Only freeze bottles and cans with beverages if you have activated the BottleTimer function in the SmartDevice app.

Freezing quantity	Arranging your food properly
Small amount of food to freeze	Place packaged food in the top drawer. If possible, place groceries at the back of the drawer near the rear wall.
Maximum amount of food to freeze	Distribute packaged groceries throughout all drawers, but only place frozen food in the bottom drawer. If possible, place groceries at the back of the drawer near the rear wall.

6.2.2 Defrosting food



WARNING

Risk of food poisoning!

- ▶ Do not re-freeze thawed food.
- ▶ Use defrosted foodstuff as soon as possible.

You can defrost food in several ways:

- In a fridge
- In the microwave
- In the oven/fan-assisted oven
- At room temperature
- ▶ Take out only as much food as necessary.

6.3 Storage times

Refer to the specified storage times as a guide.

In the case of foods with a minimum shelf life, the date indicated on the packaging still applies.

6.3.1 Freezer compartment

Recommended storage period for various types of food		
Ice cream	at -18 °C	2 to 6 months
Sausages, ham	at -18 °C	2 to 3 months
Bread, baked goods	at -18 °C	2 to 6 months
Game, pork	at -18 °C	6 to 9 months

Recommended storage period for various types of food		
Fatty fish	at -18 °C	2 to 6 months
Lean fish	at -18 °C	6 to 8 months
Cheese	at -18 °C	2 to 6 months
Poultry, beef	at -18 °C	6 to 12 months
Vegetables, fruit	at -18 °C	6 to 12 months

7 Saving energy

- Pay attention to good ventilation. Do not cover ventilation holes or grids.
- Always keep the fan air slits clear.
- Do not place the appliance in direct sunlight or near radiators or similar sources of heat.
- If the appliance is placed directly next to an oven, the energy consumption may increase slightly. This is dependent on the service life and usage intensity of the oven.
- Energy consumption depends on the installation conditions, e.g. the ambient temperature (see 2.4 Appliance range of use) . A warmer ambient temperature can increase the energy consumption.
- Open the appliance for as short a time as possible.
- The lower the temperature is set the higher the energy consumption.
- Inserting warm food: allow to cool down to room temperature first.

8 Controls

8.1 Controls and displays

8.1.1 Status display

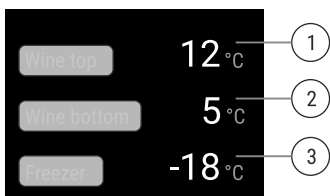



Fig. 53 The status display shows the actual temperature.





- (1) Upper wine compartment temperature display
- (2) Lower wine compartment temperature display
- (3) Freezer compartment temperature display

The status display shows the actual temperature and is the initial display. Navigation to the functions takes place from there.

8.1.2 Display symbols

Display symbols provide information on the current appliance status:

Symbol	Appliance status
	Standby The appliance or temperature zone is switched off.

Symbol	Appliance status
	Flashing number Appliance is working. Temperature flashes until the set temperature is reached.
	
	Flashing symbol Appliance is working. Setting is made.
	

8.2 Appliance functions

8.2.1 Notes on the appliance functions

The appliance functions are set at the factory so that your appliance is fully functional.

Before you alter, activate or deactivate the device functions, make sure that the following requirements are met:

- You have read and understood the descriptions of how the display works. (see 4 Functionality of the Touch & Swipe display)
- You have familiarised yourself with the operating and display elements of your appliance.



Switching the appliance off and on

Use this function to switch the entire appliance off and on.

Switching off the appliance

When you switch the appliance off, then the previously saved settings are saved.

Make sure that the following requirements are fulfilled:

- Handling instructions (see 12 Shutting down) are carried out.



Fig. 54

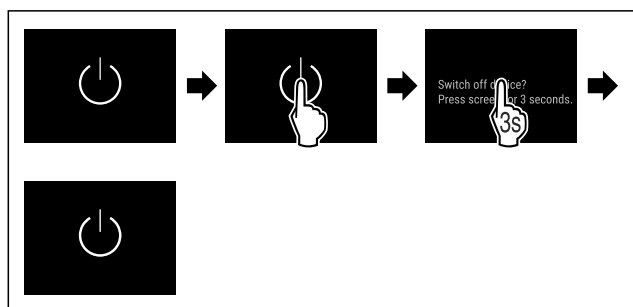

Fig. 55

- ▶ Carry out action steps according to the illustration.
- ▶ Appliance is switched off.
- ▶ The standby symbol appears in the display.
- ▶ Display turns black.

Switching on the appliance

If the display is in sleep mode:

- ▶ Briefly touch the display.

Controls

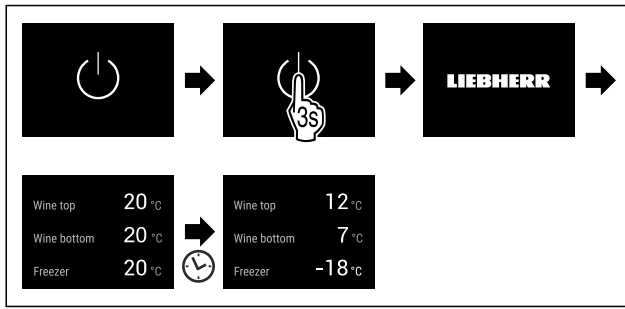

Fig. 56 Example illustration

- ▶ Carry out action steps according to the illustration. When the appliance starts in demo mode:
- ▶ Deactivating demo mode. (see Deactivating demo mode)
- ▶ The appliance is switched on.
- ▶ Previous settings are restored.
- ▶ The appliance cools to the target temperature set.

-18°C Switching temperature zone off and on

You can switch temperature zones of the appliance off independently.

Application:

- Cleaning

Switching the wine zone off

Make sure that the following requirements are fulfilled:

- Wine zone has been emptied.

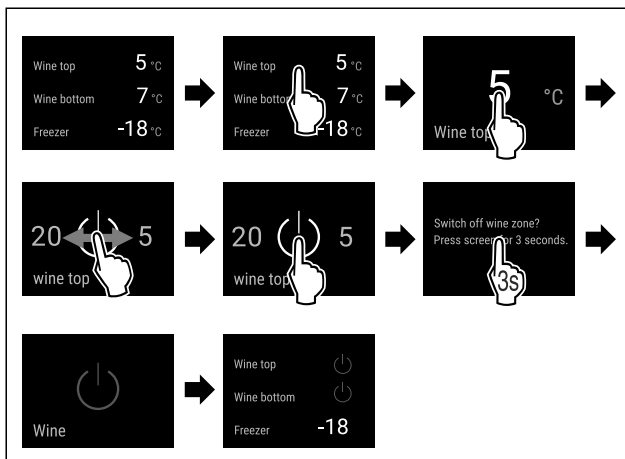

Fig. 57 Example illustration for wine zone above

- ▶ Carry out action steps according to the illustration.
- ▶ The entire wine zone is switched off.

Switching the wine zone on

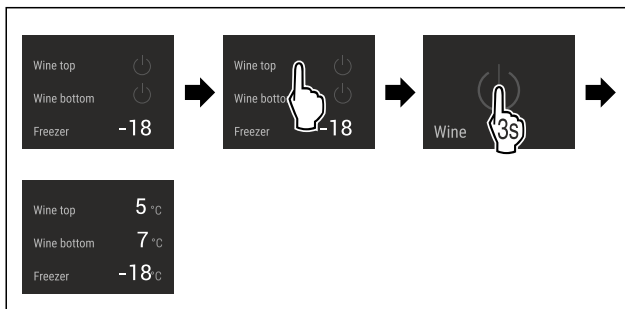

Fig. 58 Example illustration for wine zone above

- ▶ Carry out action steps according to the illustration.
- ▶ Wine zone is switched on.
- ▶ All wine zones cool to the last set temperature.

12°C Temperature

Use this function to set the temperature.

The temperature depends on the following factors:

- Frequency of door opening
- Duration of door opening
- Room temperature of the installation site
- Type, temperature and quantity of food

Temperature zone	Factory-set temperature	Recommended setting
12°C Wine section	12 °C	Depending on the type of wine
-18°C Freezer section	-18 °C	-18 °C

Setting the temperature in the wine section

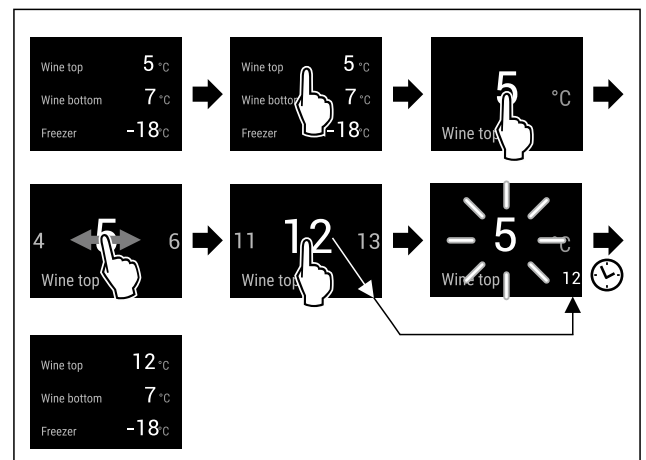

Fig. 59 Example illustration: Setting the temperature in the upper wine section.

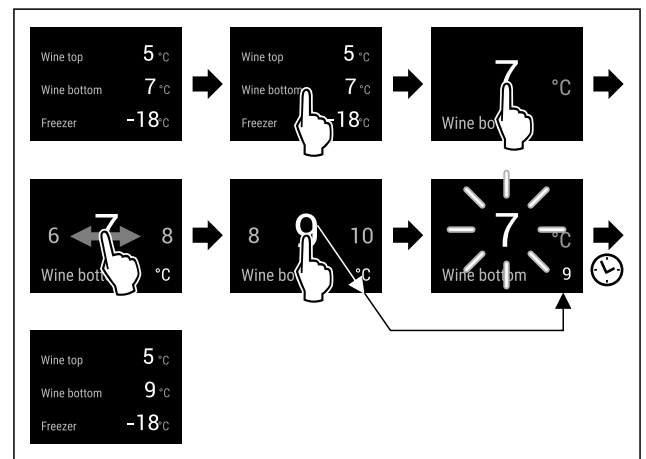

Fig. 60 Example illustration: Setting the temperature in the lower wine section.

- ▶ Carry out action steps according to the illustration.
- ▶ Temperature is set.

Setting the temperature in the freezer section

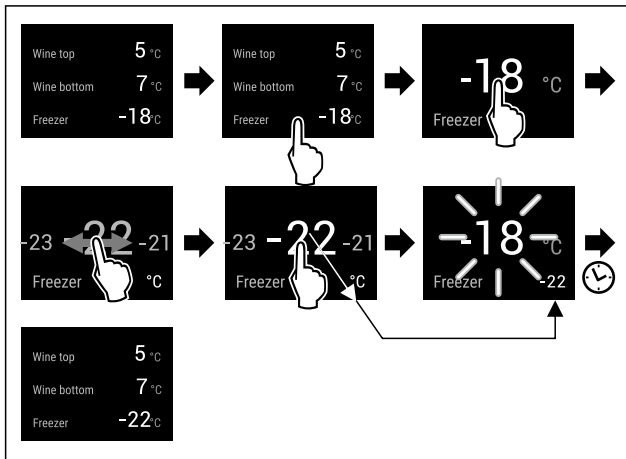

Fig. 61 Example illustration

- ▶ Carry out action steps according to the illustration.
- ▶ Temperature is set.

SuperFrost

You can use this function to activate or deactivate SuperFrost. If SuperFrost is activated, then the appliance increases the freezing capacity. It allows you to achieve lower freezing temperatures.

Application:

- Quickly freeze fresh food through to the core. This ensures that the nutrition, appearance and taste of frozen food is maintained.
- Increase the cold reserve in stored frozen food before defrosting the appliance.

If the function is active, the appliance operates at higher power. As a result, the appliance's operating noise may be temporarily louder and energy consumption will increase.

If the door is open for too long, e.g. because you are putting food in, the appliance automatically checks whether the actual temperature in the appliance matches the set temperature. If the difference exceeds a certain value, the appliance automatically cools more vigorously. As a result, the temperature shown on the display may be higher than the actual temperature in the appliance. This is normal and your appliance is working correctly.

Activating SuperFrost

Make sure that the following requirements are fulfilled:

- Freezing quantity and time for activation of SuperFrost are taken into account. (see Freezing food using SuperFrost)



Fig. 62

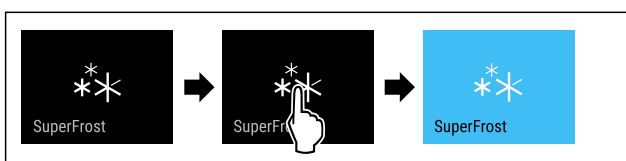

Fig. 63

- ▶ Carry out action steps according to the illustration.
- or-

- ▶ Activate with the SmartDevice app.
- ▶ SuperFrost is activated.
- ▶ The temperature display turns blue.

Deactivating SuperFrost

SuperFrost is automatically deactivated after 56 to 72 hours depending on the quantity of the food inserted. However, you can also deactivate SuperFrost manually at any time:

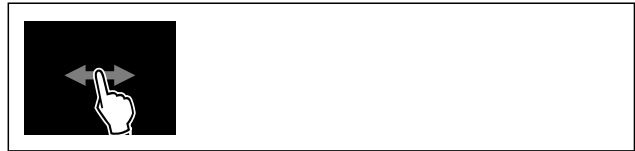

Fig. 64

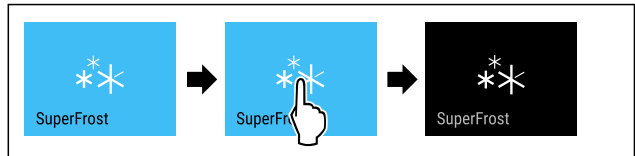

Fig. 65

- ▶ Carry out action steps according to the illustration.

-or-

- ▶ Deactivate with the SmartDevice app.
- ▶ SuperFrost is deactivated.
- ▶ The appliance continues to run in normal mode.
- ▶ The appliance cools to the temperature set previously.



PartyMode

You can use this function to activate or deactivate PartyMode. PartyMode activates various functions that are useful for a party.

PartyMode activates the following functions:

- SuperFrost (see SuperFrost)
- IceMaker with MaxIce (see IceMaker / MaxIce)

You can adjust all listed functions individually and flexibly. When you deactivate PartyMode, all changes are discarded.

If the function is active, the device operates at higher power. As a result, the device's operating noise may be temporarily louder and energy consumption will increase.

Activating PartyMode

Make sure that the following requirements are fulfilled:

- The IceMaker has been started. (see 5.2 Starting the IceMaker for the first time)



Fig. 66

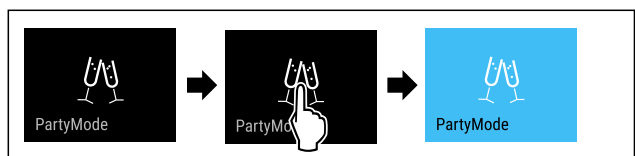

Fig. 67

- ▶ Carry out action steps according to the illustration.
- ▶ PartyMode and the associated functions are activated.
- ▶ The temperature display turns blue.
- ▶ The current temperature flashes until the target temperature is reached.

Controls

Deactivating PartyMode

The PartyMode is automatically deactivated after 24 seconds. However, you can also deactivate PartyMode manually at any time:



Fig. 68



Fig. 69

- ▶ Carry out action steps according to the illustration.
- ▶ PartyMode is deactivated.
- ▶ The appliance cools to the temperature set previously: The current temperature flashes until the target temperature is reached.



SabbathMode

You can use this function to activate or deactivate SabbathMode. If you activate this function, some electronic functions are switched off. As a result, your device meets the religious requirements for Jewish holidays such as Sabbath and complies with STAR-K Kosher certification.

Device status when SabbathMode is active
The status display shows SabbathMode permanently.
All functions on the display are locked except for the Deactivate SabbathMode function .
Active functions remain active.
The display remains bright when you close the door.
The interior lighting is deactivated.
Reminders are not implemented. The set time interval stops.
Reminders and warnings are not displayed.
There is no door alarm.
There is no temperature alarm.
The IceMaker is switched off.
After a power failure, the appliance returns to SabbathMode.

Device status

Note

This appliance has certification from the "Institute for Science and Halacha". (www.machonhalacha.co.il)
You can find a list of STAR-K-certified appliances at www.star-k.org/appliances.

Activating SabbathMode



Fig. 70

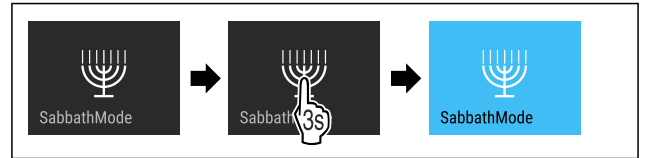

Fig. 71

- ▶ Carry out action steps according to the illustration.
- ▶ SabbathMode is activated.
- ▶ The status display shows SabbathMode permanently.

Deactivating SabbathMode

The SabbathMode is automatically deactivated after 80 hours. However, you can also deactivate SabbathMode manually at any time:

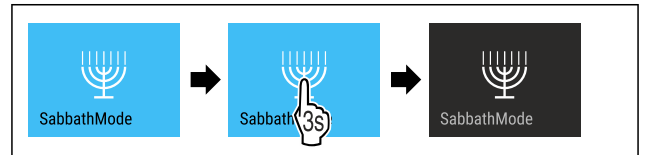

Fig. 72

- ▶ Carry out action steps according to the illustration.
- ▶ SabbathMode is deactivated.



EnergySaver

You can use this function to activate or deactivate Energy saving mode. If energy saving mode is activated, the energy consumption decreases and the temperature in the device increases. The food remains fresh, but the shelf life is shortened.

Activating EnergySaver



Fig. 73

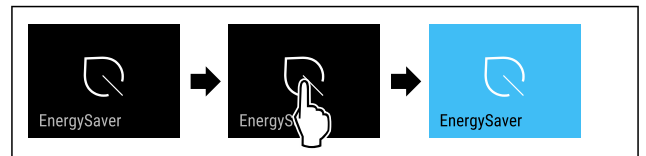

Fig. 74

- ▶ Carry out action steps according to the illustration.
- ▶ Energy saving mode is activated.

Deactivating EnergySaver



Fig. 75

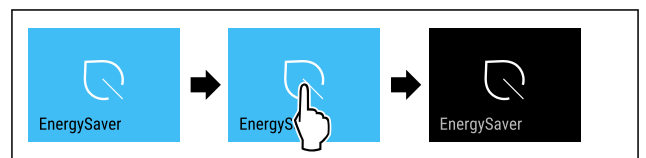

Fig. 76

- ▶ Carry out action steps according to the illustration.
- ▶ Energy saving mode is deactivated.

IceMaker / MaxIce

Use the IceMaker function to activate or deactivate the production of ice cubes. Use the MaxIce function to increase the amount of ice cubes produced by the IceMaker. MaxIce is automatically deactivated after 48 hours. However, you can also deactivate MaxIce manually at any time: (see Deactivating MaxIce)

More information on the number of ice cubes:	(see 11.1 Technical specifications)
Further information on the IceMaker water supply:	(see IceMaker water supply)
More information on cleaning the lines of the IceMaker:	(see TubeClean)

If the function is active, the device operates at higher power. As a result, the device's operating noise may be temporarily louder and energy consumption will increase.

Activating IceMaker

Make sure that the following requirements are fulfilled:

- The water supply is established at the fixed water connection. See installation instructions.
- IceMaker is put into operation. (see 9.3 IceMaker)



Fig. 77

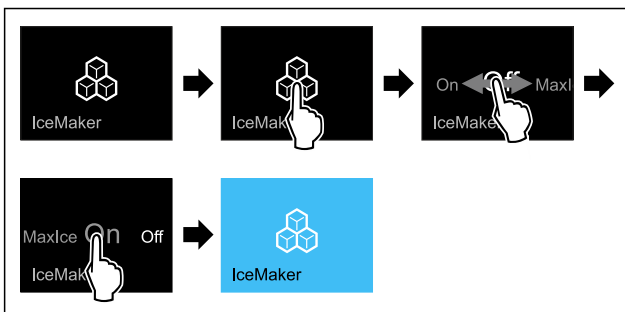

Fig. 78

- ▶ Carry out action steps according to the illustration.
- or-
- ▶ Activate with the SmartDevice app.
- ▶ IceMaker is activated. It can take up to 24 hours for the IceMaker to produce the first ice cubes.

Activating the IceMaker with MaxIce

If you have not activated the IceMaker function before, make sure that the following requirements are met:

- The water supply is established at the fixed water connection. See installation instructions.
- IceMaker is put into operation. (see 9.3 IceMaker)

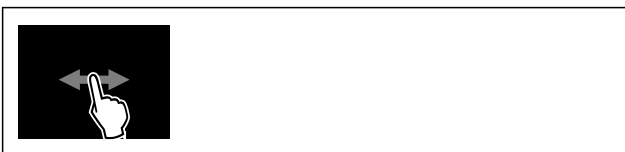

Fig. 79

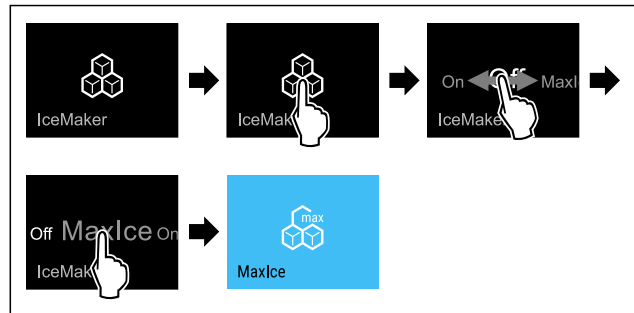

Fig. 80

- ▶ Carry out action steps according to the illustration.
- or-
- ▶ Activate with the SmartDevice app.
- ▶ The IceMaker is activated with MaxIce.

Changing between the IceMaker and MaxIce

If you have activated the IceMaker and would like to change to MaxIce:



Fig. 81

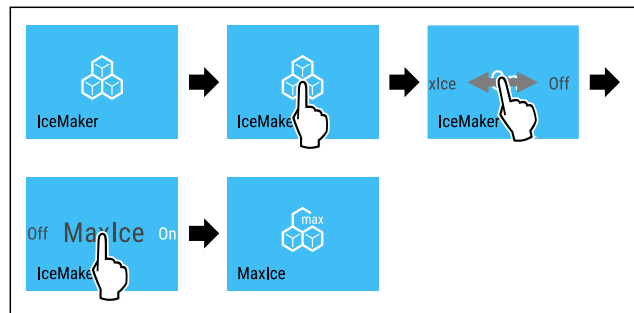

Fig. 82

- ▶ Carry out action steps according to the illustration.
- ▶ The IceMaker is activated with MaxIce.

If you have activated MaxIce and would like to change to the IceMaker:



Fig. 83

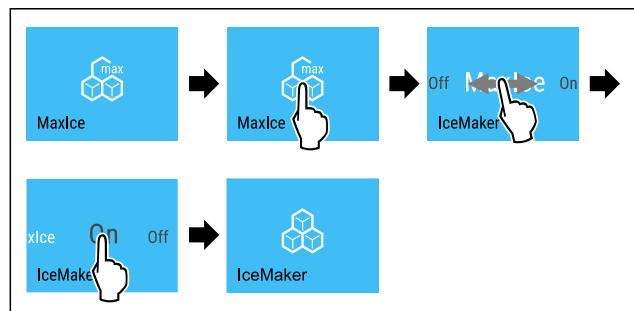

Fig. 84

- ▶ Carry out action steps according to the illustration.
- ▶ IceMaker is activated.
- ▶ MaxIce is deactivated.

Controls

Deactivating the IceMaker and MaxIce



Fig. 85

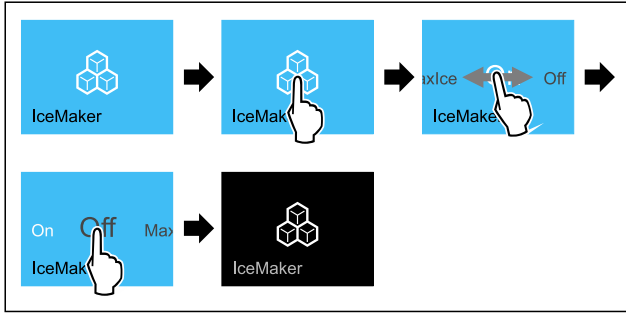

Fig. 86 Example illustration of the active IceMaker function

- ▶ Carry out action steps according to the illustration.
- or-
- ▶ Deactivate with the SmartDevice app.
- ▶ IceMaker and MaxIce are deactivated.
- ▶ If ice cubes are currently being made, the system completes the process.
- ▶ The IceMaker goes off automatically.

Deactivating MaxIce

- ▶ Activate the IceMaker. (see Activating IceMaker)
- ▶ MaxIce is deactivated.
- ▶ IceMaker is activated.
- ▶ To deactivate the IceMaker and MaxIce: (see Deactivating the IceMaker and MaxIce)

5

IceMaker water supply

Use this function to set the water supply. The water supply regulates the amount of water supplied. The water supply can be changed if it does not match the water pressure and the ice cube size dispensed.

The water supply is pre-set to value 4 as delivered. A value from 1 (smallest inflow volume) to 8 (largest inflow volume) can be selected.

Setting water supply

Make sure that the following requirements are fulfilled:

- The IceMaker has been started. (see 5.2 Starting the IceMaker for the first time)
- IceMaker is activated. (see IceMaker / MaxIce)



Fig. 87

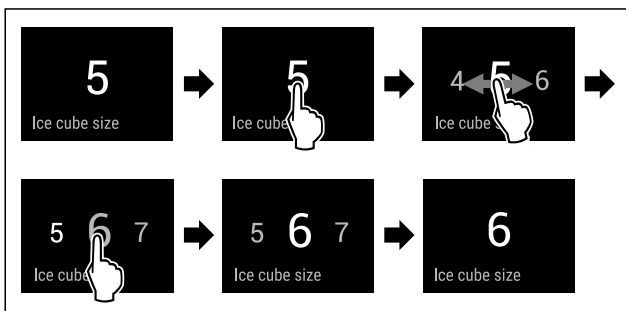

Fig. 88 Example illustration: Switch from value 5 to value 6.

- ▶ Carry out action steps according to the illustration.
- ▶ The water supply is set.



TubeClean

You can use this function to activate or deactivate TubeClean. If TubeClean is activated, it cleans the IceMaker lines.

Activating TubeClean

Make sure that the following requirements are fulfilled:

- IceMaker cleaning is prepared. (see 10.4.5 Cleaning the IceMaker)
- Empty container with a capacity of 1.5 l and with a maximum height of 10 cm is ready.
- ▶ Place the container in the drawer under the IceMaker.



Fig. 89

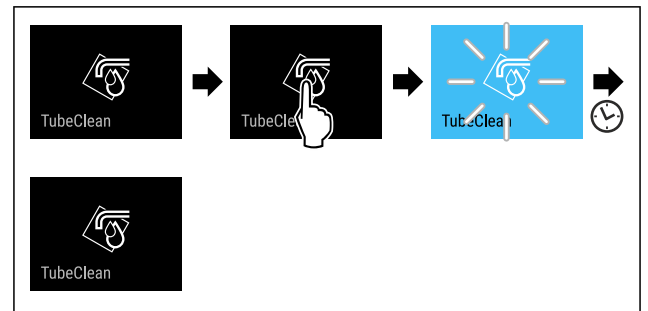

Fig. 90

- ▶ Carry out action steps according to the illustration.
- ▶ TubeClean is activated.
- ▶ The cleaning process has started: Icon flashes until the cleaning process is automatically completed after 60 minutes.
- ▶ When the cleaning process is complete: The device continues to run in normal mode.

Deactivating TubeClean

TubeClean is automatically ended after 60 minutes. However, TubeClean can also be deactivated at any time during the cleaning process:

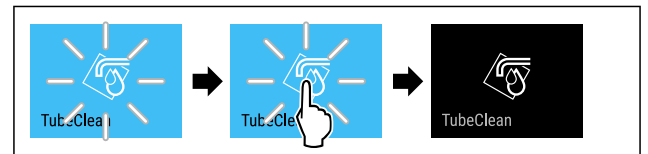

Fig. 91

- ▶ Carry out action steps according to the illustration.
- ▶ TubeClean is deactivated: Cleaning process is aborted.
- ▶ The device continues to run in normal mode.



Input lock

You can use this function to activate or deactivate the input lock. The input lock prevents the appliance being operated accidentally, e.g. by children.

Application:

- Avoid unintentional modification of functions.

- Avoid unintentional switching off of the device.
- Avoid unintentional temperature setting.

Activating the input lock

If you activate the input lock, you can continue to navigate in the menus but you cannot select or change other functions.



Fig. 92

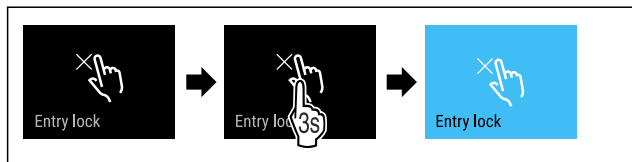

Fig. 93

- ▶ Carry out action steps according to the illustration.
- ▶ Input lock is activated.

Deactivating the input lock

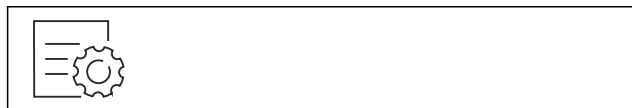

Fig. 94

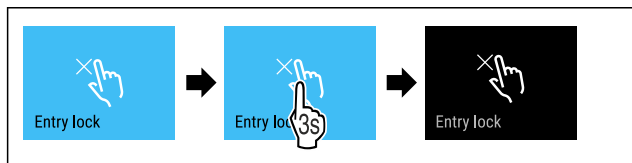

Fig. 95

- ▶ Carry out action steps according to the illustration.
- ▶ Input lock is deactivated.

Reminder

Use this function to activate or deactivate the reminders. The function is activated on delivery.

If the function is activated, the following reminders will appear:

- Replace the FreshAir activated carbon filter (see Replace the FreshAir activated carbon filter)

Activating the reminder



Fig. 96

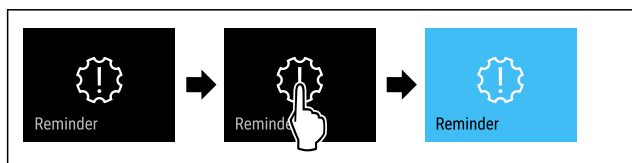

Fig. 97

- ▶ Carry out action steps according to the illustration.
- ▶ Reminder is activated.

Deactivating the reminder

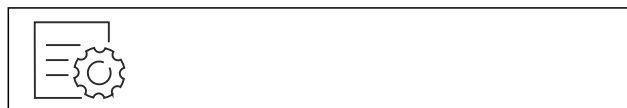

Fig. 98

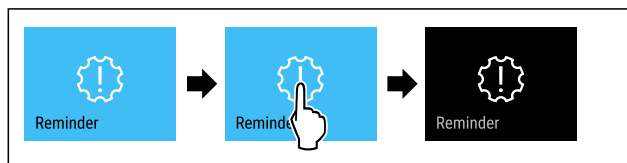

Fig. 99

- ▶ Carry out action steps according to the illustration.
- ▶ Reminder is deactivated.

Language

Use this function to set the display language.

You can select the following languages:

- Deutsch
- English
- Français
- Español
- Italiano
- Nederlands
- Čeština
- Polski
- Português
- Bulgarian
- Русский
- 温度单位

Setting the language

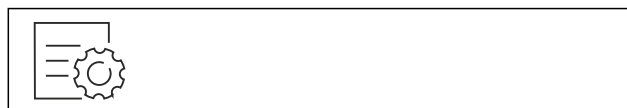

Fig. 100

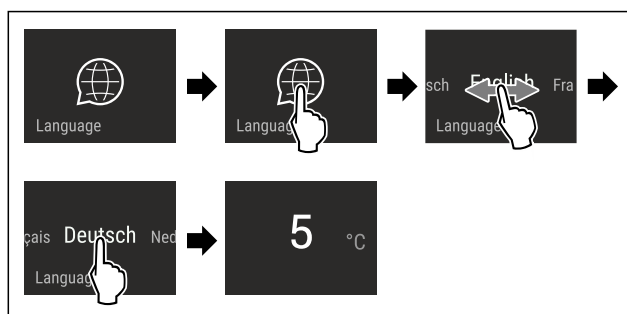

Fig. 101 Example illustration depending on the language and temperature

- ▶ Carry out action steps according to the illustration.
- ▶ The language is set.
- ▶ The display returns to the status display.

Temperature unit

Use this function to set the temperature unit. You can set degrees Celsius or degrees Fahrenheit as the temperature unit.

Controls

Setting the temperature unit



Fig. 102

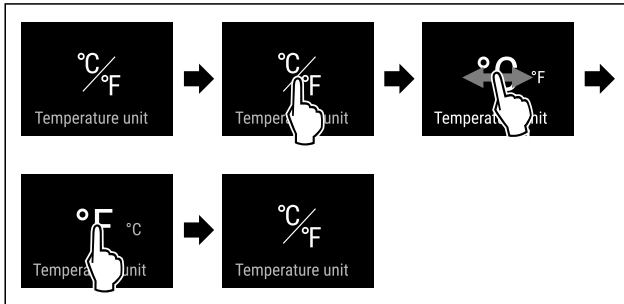

Fig. 104 Example illustration: Switch from degrees Celsius to degrees Fahrenheit.

- ▶ Carry out action steps according to the illustration.
- ▷ The temperature unit is set.

Display brightness

Use this function to set the display brightness in stages.

You can select the following brightness levels:

- 40 %
- 60 %
- 80 %
- 100 % (pre-setting)

Setting the brightness



Fig. 105

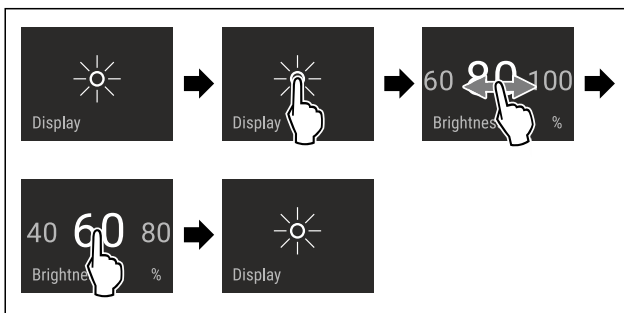

Fig. 106 Example illustration: Switch from 80 % to 60 %.

- ▶ Carry out action steps according to the illustration.
- ▷ The brightness is set.

WiFi

Use this function to connect your appliance to WiFi. You can then operate it via the SmartDevice app on a mobile device. You can also use this function to disconnect or reset the WiFi connection.

More information on the SmartDevice: (see 2.3 SmartDevice)

Note

The SmartDevice function is not available in the following countries: Russia, Belarus, Kazakhstan.

Establishing the WiFi connection for the first time

Make sure that the following requirements are fulfilled:

- You have installed the SmartDevice app (see apps.home.liebherr.com).
- Registration in the SmartDevice app is completed.



Fig. 107

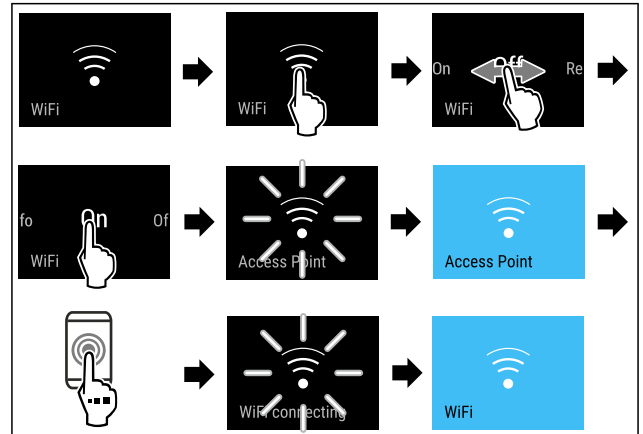

Fig. 108

- ▶ Carry out action steps according to the illustration.
- ▷ Connection is established.

Disconnecting from the WiFi



Fig. 109

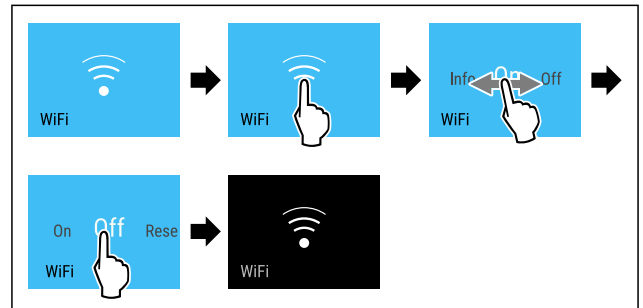

Fig. 110

- ▶ Carry out action steps according to the illustration.
- ▷ There is no connection.

Resetting the WiFi connection



Fig. 111

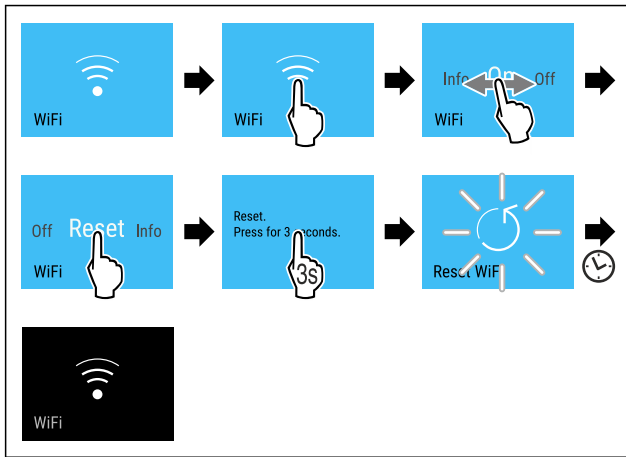

Fig. 112

- ▶ Carry out action steps according to the illustration.
- ▶ WiFi connection and other WiFi settings are reset to factory settings.

Showing information about the WiFi connection



Fig. 113

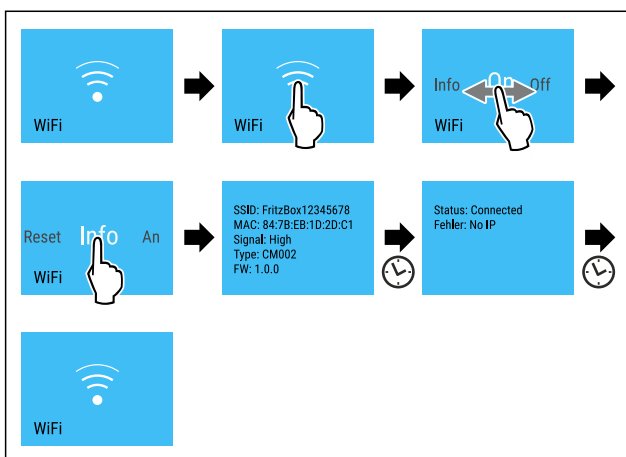

Fig. 114

- ▶ Carry out action steps according to the illustration.

Device information

Use this function to indicate the model name, index, serial number and service number of your device. You will need the device information when you contact customer service. (see 11.4 Customer Service)

This function also opens the Advanced menu. (see 4 Functionality of the Touch & Swipe display)

Indicating the device information



Fig. 115



Fig. 116

- ▶ Carry out action steps according to the illustration.
- ▶ Display indicates device information.

Software

Use this function to indicate the software version of your device.

Indicating the software version



Fig. 117



Fig. 118

- ▶ Carry out action steps according to the illustration.
- ▶ Display indicates software version.

Start defrosting cycle

Use this function to start the automatic defrosting cycle manually if it does not start automatically in the event of a fault.

Starting defrosting cycle



Fig. 119

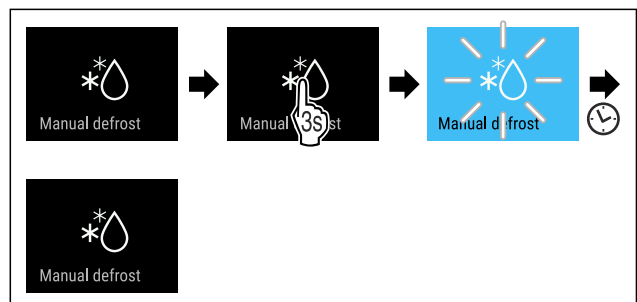

Fig. 120

- ▶ Carry out action steps according to the illustration.
- ▶ Defrosting cycle has started: Icon flashes until defrosting cycle is automatically completed.
- ▶ When defrosting cycle is finished: The device continues to run in normal mode.

Cancelling defrosting cycle

The defrosting cycle will be stopped automatically. However, you can also cancel the defrosting cycle at any time during the defrosting process:

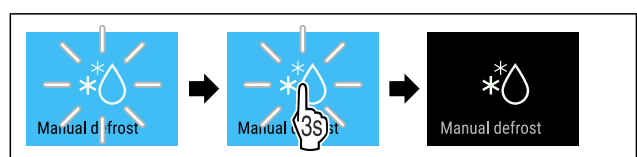

Fig. 121

- ▶ Carry out action steps according to the illustration.

Controls

- ▶ Defrosting cycle is cancelled.
- ▶ The device continues to run in normal mode.



Door alarm

Use this function to activate or deactivate the door alarm. The door alarm sounds if the door is open for too long. The door alarm is activated on delivery. You can set how long the door may be open before the door alarm sounds.

The following values can be set:

- 1 minute
- 2 minutes
- 3 minutes
- Off

Setting the door alarm



Fig. 122

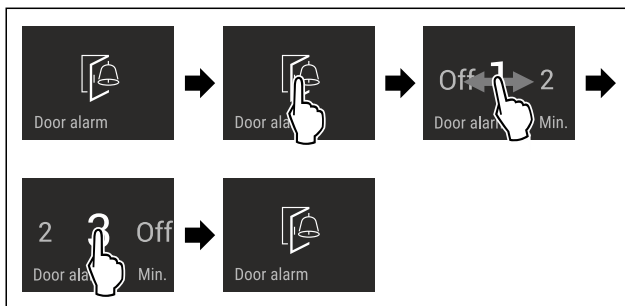

Fig. 123 Example illustration: Change door alarm from 1 minute to 3 minutes.

- ▶ Carry out action steps according to the illustration.
- ▶ The door alarm is set.

Deactivating the door alarm

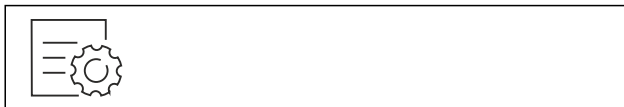

Fig. 125

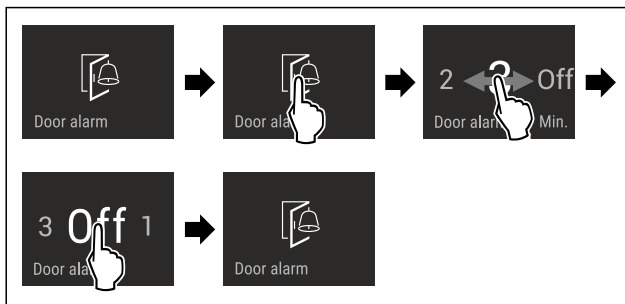

Fig. 126

- ▶ Carry out action steps according to the illustration.
- ▶ The door alarm is deactivated.



Demo mode

Demo mode is a special feature for dealers who want to demonstrate appliance features. If you activate demo mode, all refrigeration functions are deactivated.

If you switch on your appliance and “Demo” appears in the status display, then demo mode is already activated.

If you activate and then deactivate demo mode, the appliance will be reset to factory defaults. (see Resetting to factory settings)

Activating demo mode



Fig. 127

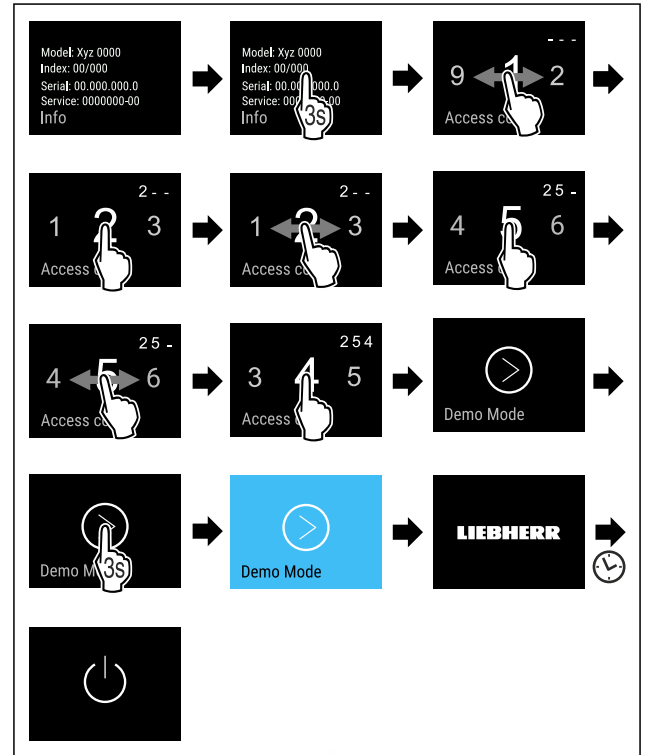

Fig. 128

- ▶ Carry out action steps according to the illustration.
- ▶ Demo mode is activated.
- ▶ Appliance is switched off.
- ▶ Switch on the appliance. (see 5.1 Switching on appliance (first use))
- ▶ “DEMO” appears in the status display.

Deactivating demo mode

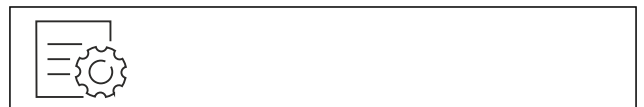

Fig. 129

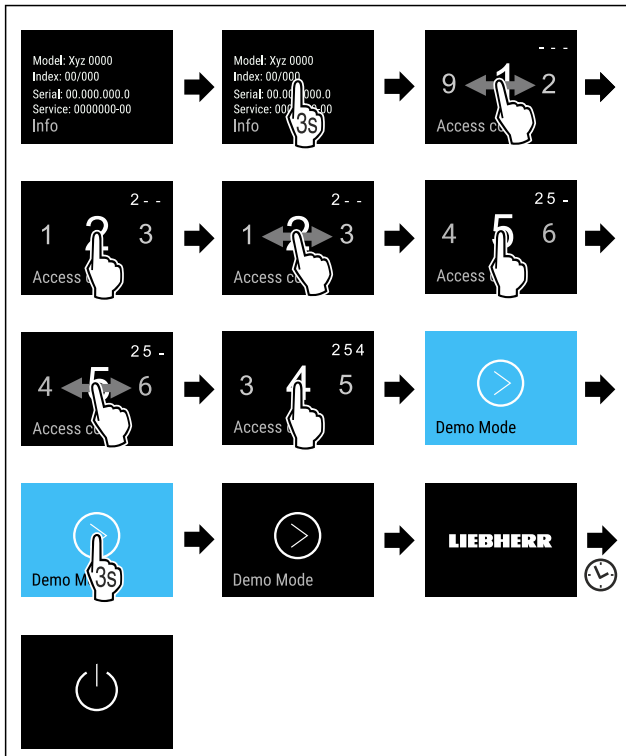

Fig. 130

- ▶ Carry out action steps according to the illustration.
- ▶ Demo mode is deactivated.
- ▶ Appliance is switched off.
- ▶ Switch on the appliance. (see 5.1 Switching on appliance (first use))
- ▶ Appliance is reset to factory settings.

Resetting to factory settings

Use this function to reset all settings to factory defaults. All settings you have made so far are reset to their original settings.

Performing a reset



Fig. 131

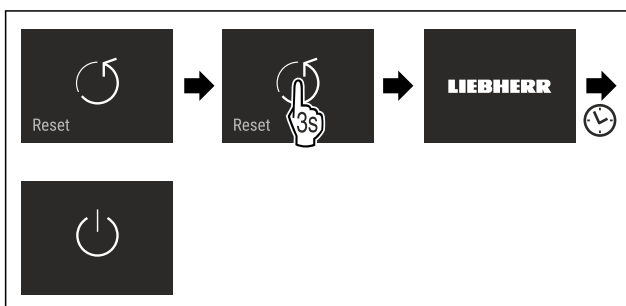

Fig. 132

- ▶ Carry out action steps according to the illustration.
- ▶ Device is reset.
- ▶ Device is switched off.
- ▶ Restart the device. (see 5.1 Switching on appliance (first use))

8.3 Messages



There are two categories of messages:

Category	Importance
Warning	Warnings appear in the event of a door alarm or malfunction. Simple warnings can be cancelled by yourself. In the event of serious malfunctions, you must contact customer service. (see 11.4 Customer Service)
Reminder	Reminders remind you of general processes. You can carry out these operations to end the message.

8.3.1 Overview of warnings

Behaviour of the appliance in the event of warnings:

- Warning appears in red on the display.
- The alarm tone sounds at an ever-increasing volume.
- The interior lighting pulsates for some warnings.

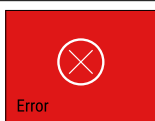
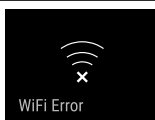
Message	Cause	Exit the message
 Door alarm	The message appears if the door is open for too long.	Carry out action steps. (see Door alarm)
 Power outage alarm	The message appears if the freezing temperature has risen due to a power failure.	
 Temperature alarm	The message appears if the freezing temperature does not correspond to the set temperature.	Carry out action steps. (see Temperature alarm)
 Error	The message appears if there is an appliance error. A component of the appliance has a fault.	Carry out action steps. (see Error)
 WiFi error	The message appears if the appliance could not be connected to the WLAN. (see Establishing the WiFi connection for the first time) The message only appears during the initial setup.	Carry out action steps. (see WLAN error)

8.3.2 Ending warnings

Door alarm

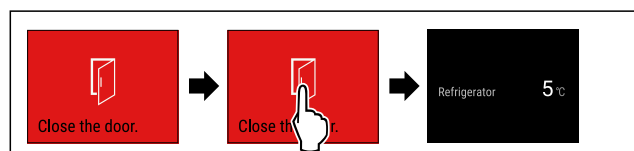

Controls

Fig. 133 Example illustration

- ▶ Carry out action steps according to the illustration.
- or-
- ▶ Close the door.
- ▶ The display returns to the status indicator.
- ▶ The appliance cools more vigorously, which means that the temperature shown on the display may be higher than the actual temperature inside the appliance.
- ▶ Appliance noises can be louder.

You can set how long the door may be open before the door alarm sounds. (see Setting the door alarm)

Power outage alarm

When the power failure has ended, the appliance will automatically cool down to the previously set target temperature without you having to confirm the message. However, for the message to disappear from the display, you must confirm it.

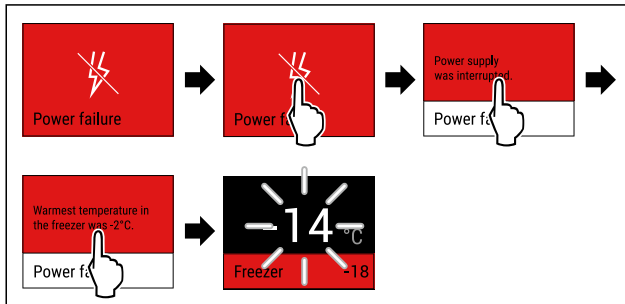

Fig. 134 Example illustration

- ▶ Briefly touch the display.
- ▶ Display shows information about the warning.
- ▶ Briefly touch the display.
- ▶ Warmest freezing temperature is displayed.
- ▶ If the freezing temperature was below -9 °C: Food can still be consumed.
- ▶ If the freezing temperature has risen above -9 °C:
 - ▶ Check the food.
 - ▶ Briefly touch the display.
- ▶ The display returns to the status indicator: Current temperature and target temperature are displayed.

Temperature alarm

Temperature differences can be caused by:

- You have put in warm, fresh food.
- Too much warm air has got in while you were sorting out the freezer or removing items.
- There has been a longer power failure.
- The appliance is faulty.
- ▶ Eliminate causes.
- ▶ The appliance cools to the target temperature set previously.

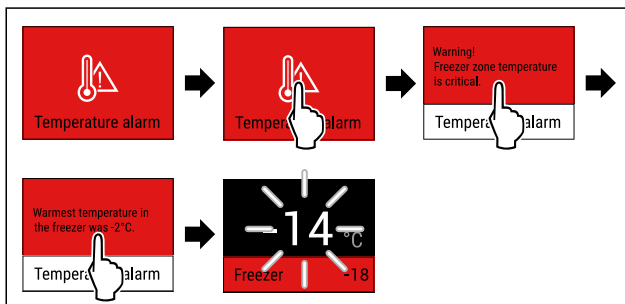

Fig. 135 Example illustration

- ▶ Briefly touch the display.
- ▶ Display shows information about the warning.
- ▶ Briefly touch the display.
- ▶ Warmest freezing temperature is displayed.

- ▶ If the freezing temperature was below -9 °C: Food can still be consumed.
- ▶ If the freezing temperature has risen above -9 °C:
 - ▶ Check the food.
 - ▶ Briefly touch the display.
- ▶ The display returns to the status indicator: Current temperature and target temperature are displayed.

Error

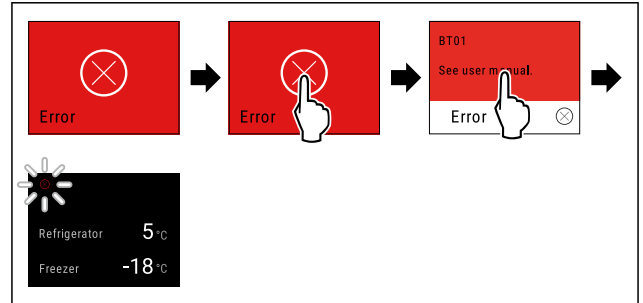

Fig. 136 Example illustration

- ▶ Briefly touch the display.
- ▶ Error code is displayed.
- ▶ Note the error code.
- ▶ Briefly touch the display.
- ▶ The display returns to the status indicator.
- ▶ Contact Customer Service. (see 11.4 Customer Service)

WLAN error

- ▶ Check WLAN connection.
- ▶ Reconnect the appliance to the WLAN. (see WiFi)

8.3.3 Overview of reminders

Behaviour of the appliance during reminders:

- Reminder appears yellow on the display.
- Alarm tone sounds.
- The interior lighting pulsates for some reminders.

The following reminders can be deactivated (see Deactivating the reminder):

- Replace the FreshAir activated carbon filter

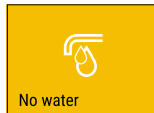
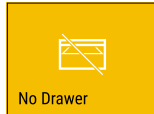
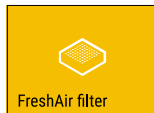
Message	Cause	Exit the message
 No water Check the water connection	The message appears if the IceMaker is activated but the IceMaker is not being supplied with water via the fixed water connection.	Carry out action steps. (see Check the water connection)
 No Drawer Insert the IceMaker drawer	The message appears if the IceMaker is activated but the IceMaker drawer is open.	Carry out action steps. (see Insert the IceMaker drawer)
 FreshAir filter Replace the FreshAir activated carbon filter	The message appears when the FreshAir activated carbon filter needs to be replaced.	Carry out action steps. (see Replace the FreshAir activated carbon filter)

8.3.4 Ending reminders

Check the water connection

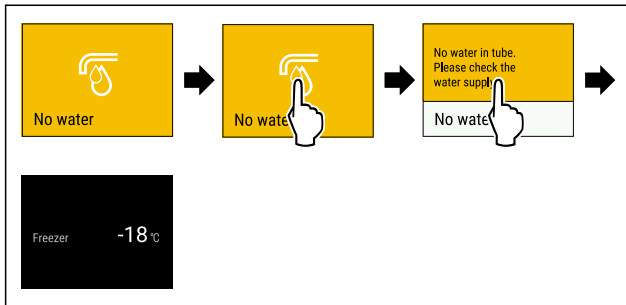

Fig. 137 Example illustration

- ▶ Briefly touch the display
- ▶ Display shows reminder information.
- ▶ Briefly touch the display
- ▶ Check the water connection.

-or-

- ▶ Deactivate IceMaker. (see Deactivating the IceMaker and MaxIce)

If water connection is checked and IceMaker is activated:

- ▶ Clean the IceMaker. (see 10.4.5 Cleaning the IceMaker)
- ▶ IceMaker produces ice cubes.

Insert the IceMaker drawer

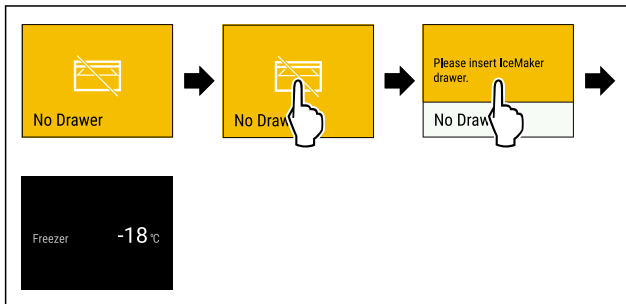

Fig. 138 Example illustration

- ▶ Briefly touch the display.
- ▶ Display shows reminder information.
- ▶ Briefly touch the display.
- ▶ Insert the IceMaker drawer.

-or-

- ▶ Deactivate IceMaker. (see IceMaker / MaxIce)

- ▶ If IceMaker drawer is inserted and IceMaker is activated: IceMaker produces ice cubes.

Replace the FreshAir activated carbon filter

Liebherr recommends: Replace the FreshAir activated carbon filter every 6 months.

Note

FreshAir activated charcoal filters can be purchased from the Liebherr-Hausgeräte store at home.liebherr.com/shop/de/deu/zubehor.html.

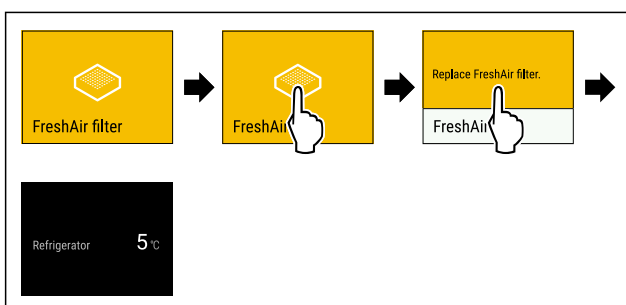

Fig. 139 Example illustration

- ▶ Briefly touch the display.

- ▶ Display shows reminder information.
 - ▶ Briefly touch the display.
 - ▶ Replace the activated carbon filter. (see 10.1 FreshAir activated carbon filter)
 - ▶ Activated carbon filter ensures optimum air quality in the cooling unit.
 - ▶ Reminder appears again after 6 months.
- If you no longer wish to receive this reminder, you can deactivate it. (see Deactivating the reminder)

9 Features

9.1 Wooden grid

The appliances are equipped with a wooden grid for wine storage.

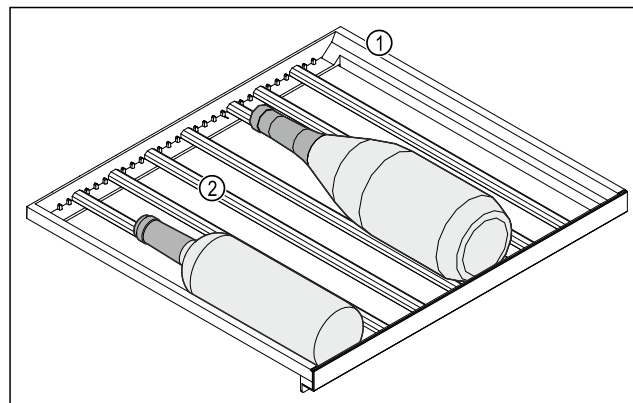

Fig. 140 Example illustration

(1) Wooden grid (2) Bar

The standard positions for the bars are indicated by notches. If you use these, you can store the maximum number of bottles.

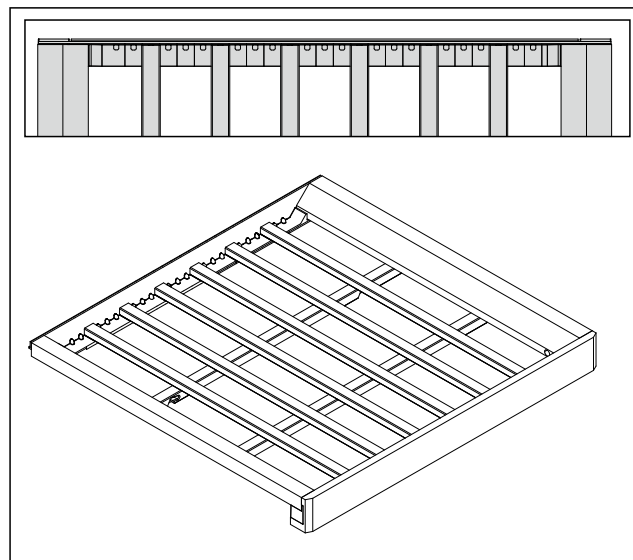

Fig. 141 Arrangement of the bars for maximum number of bottles.

Features

9.1.1 Moving the bar

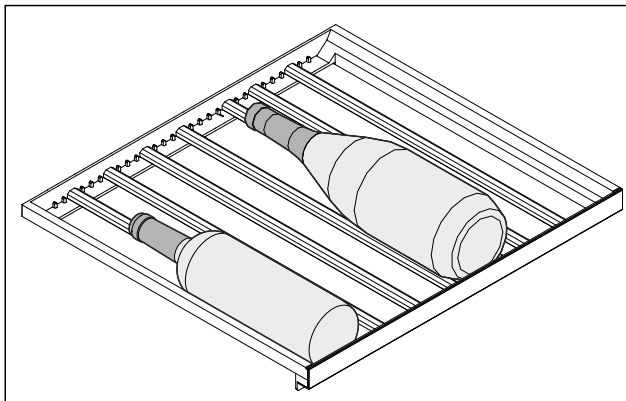

Fig. 142 Example illustration

You can remove the bars in the wooden rack to store larger or smaller bottles.

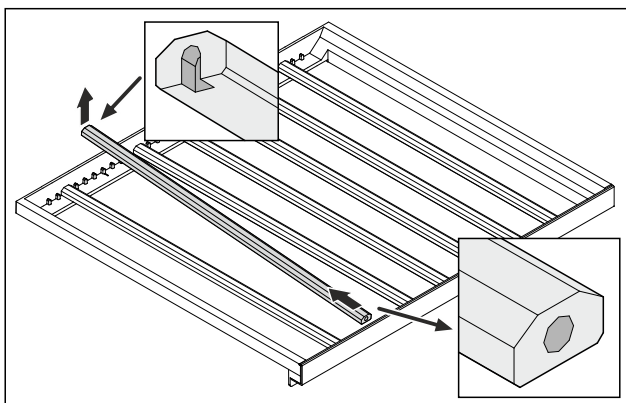

Fig. 143 Example illustration

► Lift and pull out the bar at the rear.

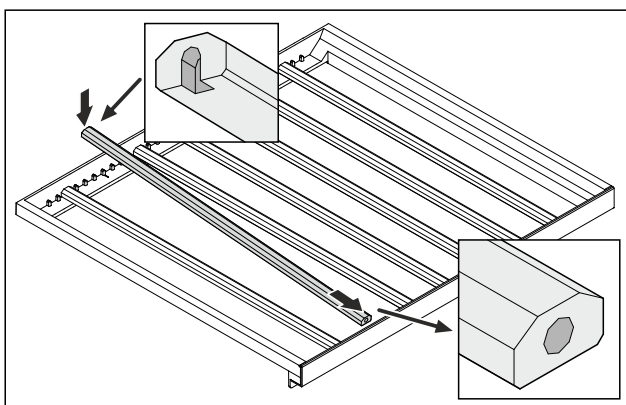

Fig. 144 Example illustration

► Insert the bar in the desired position.

9.2 Drawers

You can remove the drawers for cleaning.

The way to remove/insert the drawers varies depending on the pull-out system. Your appliance can contain various pull-out systems.

Note

The energy consumption increases and the cooling power goes down if ventilation is not sufficient.

- Leave the bottom drawer inside the appliance.
- Always keep the inside vents at the rear wall clear.

9.2.1 Drawer on telescopic rails

The drawer runs on extendible rails (telescopic rails). There are fully extendible telescopic rails and telescopic rails with partial pull-out. Drawers which are fully extendible can be pulled out fully from the appliance. Drawers with partial pull-out cannot be removed fully from the appliance. The system in your appliance depends on the type of appliance.

Partial pull-out freezer compartment

Note

If the magnet on the top drawer in the freezer compartment is damaged or removed, the door sensors will malfunction.

- Do not damage or remove the magnet.

Removing drawer

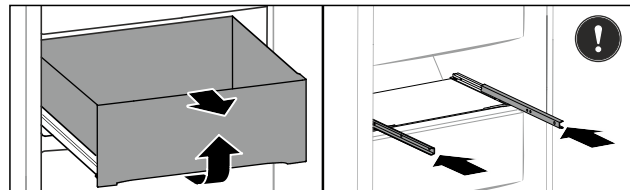

Fig. 145

If the drawer is in the top freezer:

- Pull out drawer as far as it will go.
- Raise the drawer forwards.
- Remove the drawer forwards.
- Slide rails in.

-or-

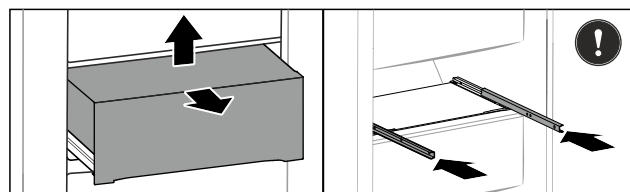

Fig. 146

If the drawer is in the middle part of the freezer compartment:

- Pull out drawer half-way.
- Lift the drawer from the bottom rear.
- Remove the drawer forwards.
- Slide rails in.

Inserting drawer

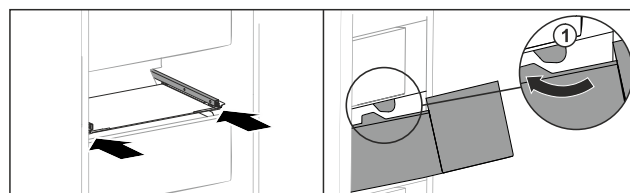

Fig. 147

- Slide rails in.
- Guide drawer around the stoppers Fig. 147 (1).
- Place drawer on rails.
- Slide in drawer to the back.

9.3 IceMaker

The IceMaker will produce ice cubes for household use only.

Ensure that the following conditions are met:

- The IceMaker is clean. (see 10 Maintenance)
- IceMaker drawer is cleaned.
- IceMaker drawer is fully inserted.

9.3.1 Producing ice cubes

The volume depends on the freezing temperature. The colder the temperature, the more ice cubes the system can produce in a certain time period.

After the IceMaker is turned on for the first time, it can take up to 24 hours for the first ice cubes to be made.

- ▶ Activate the IceMaker function.
- ▶ Producing many ice cubes: Activate the MaxIce function.
- ▶ To make a high number of ice cubes: Move the divider in the IceMaker drawer or remove it completely.
- ▶ Distribute the ice cubes evenly in the drawer to increase the capacity.
- ▶ Closing the drawer: IceMaker starts making ice cubes again automatically.

Note

When a certain level is reached in the IceMaker drawer, it stops producing ice cubes. The IceMaker does not fill the drawer all the way to the top.

9.4 Flexible ice compartment divider

The IceMaker's ice cube drawer has a flexible ice compartment divider. This allows you to store larger quantities of ice cubes or additional food items as needed. You can move or remove the ice compartment divider.

9.4.1 Moving in the flexible ice compartment divider

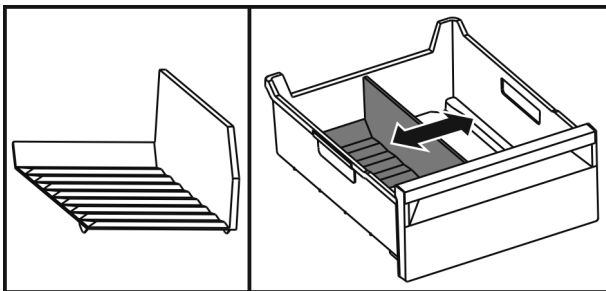

Fig. 148 Example illustration of the ice compartment divider

- ▶ Move the ice compartment divider to the desired position.

9.4.2 Removing the flexible ice compartment divider

Make sure that the following requirements are fulfilled:

- ☐ Ice cube drawer is removed. (see 9.2 Drawers)

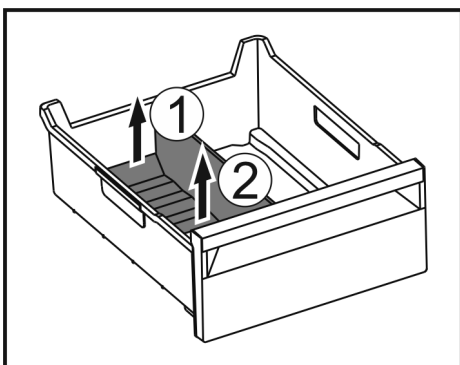

Fig. 149

- ▶ Lift the rear part of the ice compartment divider. Fig. 149 (1)
- ▶ Remove the ice compartment divider upwards. Fig. 149 (2)

9.4.3 Putting in the flexible ice compartment divider

Make sure that the following requirements are fulfilled:

- ☐ Ice cube drawer is removed. (see 9.2 Drawers)

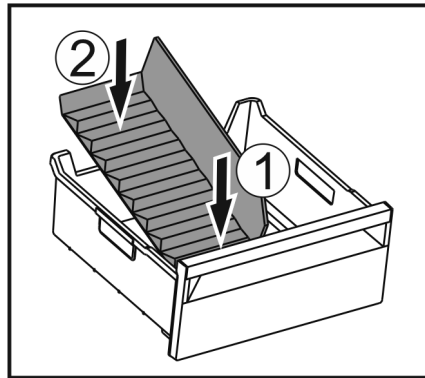

Fig. 150

- ▶ Insert the front part of the ice compartment divider. Fig. 150 (1)
- ▶ Lower the rear part of the ice compartment divider to the drawer bottom. Fig. 150 (2)

10 Maintenance

10.1 FreshAir activated carbon filter

Wine is constantly developing according to its ambient conditions, so air quality is essential for preservation.

The FreshAir activated charcoal filter guarantees optimal air quality.

- ☐ Change the activated charcoal filter every 6 months.
- ☐ Dispose of the activated charcoal filter with regular household waste.

Note

FreshAir activated charcoal filters can be purchased from the Liebherr-Hausgeräte store at home.liebherr.com/shop/de/deu/zubehor.html.

10.1.1 Replacing the FreshAir activated charcoal filter

Must be carried out multiple times depending on the equipment.

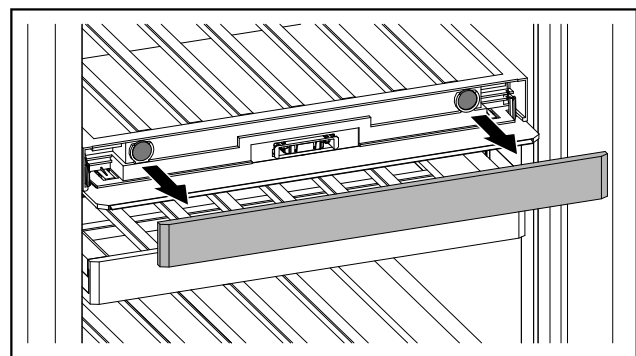

Fig. 151

- ▶ Remove the panel.

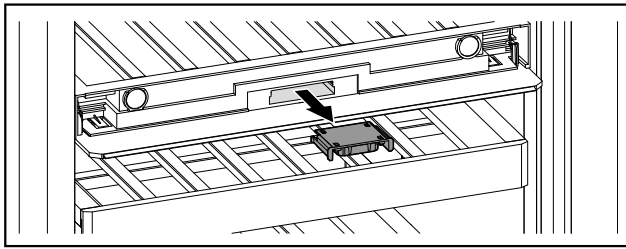

Fig. 152

- ▶ Pull the drawer out.

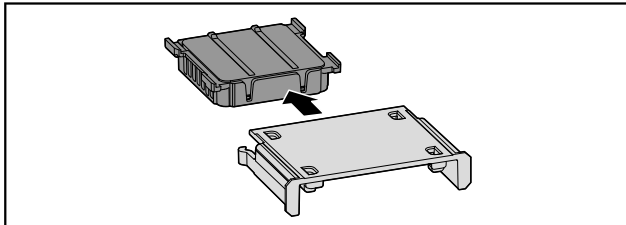

Fig. 153

- ▶ Pull out the filter.

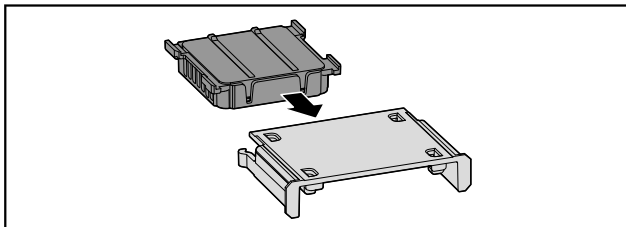

Fig. 154

- ▶ Insert the new filter.

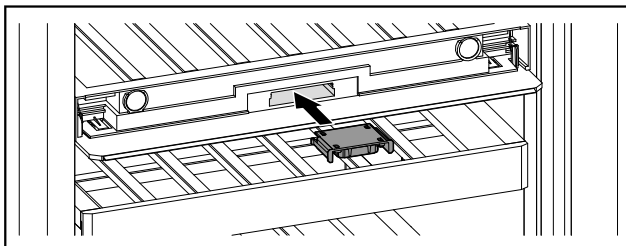

Fig. 155

- ▶ Push the drawer in.

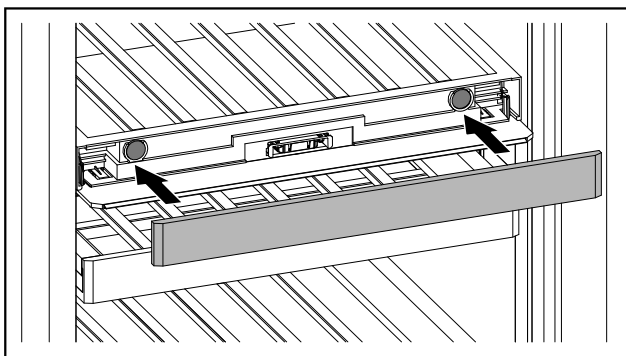

Fig. 156

- ▶ Set the panel back in place.

10.2 Disassembling / assembling pull-out systems

10.2.1 Notes on disassembly

You can disassemble some of the pull-out systems for cleaning. Your appliance can contain a variety of pull-out systems.

The following pull-out systems can be disassembled or cannot be disassembled:

Pull-out system	can be disassembled / cannot be disassembled
Freezer section partial pull-out	can be disassembled (see Partial pull-out freezer compartment)

10.2.2 Drawer on telescopic rails

Partial pull-out freezer compartment

Disassembling pull-out system

Make sure the following prerequisites are met:

- Drawer has been removed.
- Glass shelf has been removed.

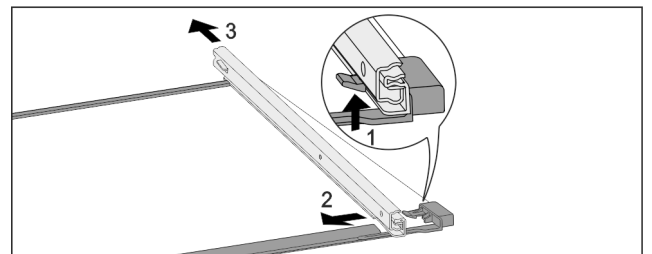

Fig. 157 Glass shelf with rails

- ▶ Push up front click-in hooks. Fig. 157 (1)
- ▶ Move the pull-out rails to the side Fig. 157 (2) and to the rear Fig. 157 (3).

Installing pull-out system

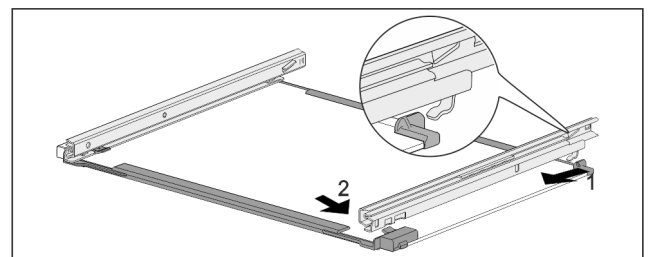

Fig. 158 Glass shelf with rails

- ▶ Hook in rail at the back. Fig. 158 (1)
- ▶ Hook in rail at the front. Fig. 158 (2)

10.3 Defrosting the appliance

Defrosting is performed automatically. The water from the thawing process drains through the outlet and evaporates.

- ▶ Clean the drain opening at regular intervals. (see 10.4 Cleaning the appliance)

10.3.2 Defrosting the freezer compartment with NoFrost

Defrosting is performed automatically with the NoFrost system. The moisture is deposited on the evaporator, is periodically defrosted and evaporates.

The appliance does not have to be defrosted.

10.4 Cleaning the appliance

10.4.1 Ready



WARNING

Danger of electric shock!

- ▶ Remove the refrigerator connector or interrupt the power supply.



WARNING

Risk of fire

- ▶ Do not damage the refrigeration circuit.

- ▶ Empty the appliance.
- ▶ Remove mains connector.

10.4.2 Clean the housing

NOTICE

Improper cleaning!

Damage to the appliance.

- ▶ Only use soft cleaning cloths and ph-neutral all-purpose cleaners.
- ▶ Do not use abrasive sponges or steel wool which may cause scratches.
- ▶ Do not use any sharp or abrasive cleaning agents, nor any that contain sand, chloride or acid.



WARNING

Risk of injury and damage as a result of hot steam!

Hot steam can lead to burns and can damage the surfaces.

- ▶ Do not use any steam cleaners!

- ▶ Wipe the housing down with soft, clean cloth. If very dirty, use lukewarm water with a neutral cleaner. Glass surfaces can also be cleaned with glass cleaner.

10.4.3 Cleaning the interior

NOTICE

Improper cleaning!

Damage to the appliance.

- ▶ Only use soft cleaning cloths and ph-neutral all-purpose cleaners.
- ▶ Do not use abrasive sponges or steel wool which may cause scratches.
- ▶ Do not use any sharp or abrasive cleaning agents, nor any that contain sand, chloride or acid.

- ▶ Plastic surfaces: clean by hand with a soft clean cloth, lukewarm water and a little detergent.
- ▶ Metal surfaces: clean by hand with a soft clean cloth, lukewarm water and a little detergent.

10.4.4 Clean the components

NOTICE

Improper cleaning!

Damage to the appliance.

- ▶ Only use soft cleaning cloths and ph-neutral all-purpose cleaners.
- ▶ Do not use abrasive sponges or steel wool which may cause scratches.
- ▶ Do not use any sharp or abrasive cleaning agents, nor any that contain sand, chloride or acid.

Clean with a soft, clean cloth, lukewarm water and some detergent:

- Drawer
Please note: Do not remove the magnet on the drawer. The magnet ensures the functionality of the IceMaker.
- Flexible ice compartment divider in the IceMaker's ice cube drawer

Clean with a damp cloth:

- Retractable rails
Please note: The grease in the tracks is used for lubrication and must not be removed!

Clean with a dry lint-free cloth:

- Wooden grating

Wash in the dishwasher up to 60 °C:

- Ice cube scoop
- ▶ To disassemble components: see the relevant section.
- ▶ Clean the components.

10.4.5 Cleaning the IceMaker

There are various options for cleaning the IceMaker.

Cleaning is required in the following cases:

- Initial operation
- With mains connection:
If out of use for more than 5 days.

Ensure that the following conditions are met:

- IceMaker drawer is emptied.
- IceMaker drawer is in place.
- The IceMaker is activated.

First use or after a long period of non-use

Clean the IceMaker with the TubeClean function.

- ▶ Put an empty 1.5 l vessel (max. height 10 cm) in the drawer under the IceMaker.
- ▶ Activate the TubeClean function.
- ▶ The rinse process is prepared (max. 60 min.): Symbol flashes.
- ▶ Water pipes are rinsed: Symbol flashes.
- ▶ Rinsing process is complete: Function turns off automatically.
- ▶ Remove the IceMaker drawer and remove the container.
- ▶ Clean the IceMaker drawer with warm water and a little detergent.
- ▶ Push the IceMaker drawer in.
- ▶ The system starts making ice cubes automatically.

Without a water filter

- ▶ Dispose of any ice cubes that were made 24 hours after the first ice cubes.

If cleaning is required

Clean the IceMaker by hand.

- ▶ Remove the IceMaker drawer and clean with warm water and a little detergent.
- ▶ Push the IceMaker drawer in.
- ▶ The system starts making ice cubes automatically.

10.4.6 After cleaning

- ▶ Wipe the appliance and the components dry.
- ▶ Connect and switch on the appliance.
- ▶ Activate SuperFrost (see 8.2 Appliance functions). The temperature is cold enough:
- ▶ Place the food inside.
- ▶ Repeat cleaning regularly.

11 Customer help

11.1 Technical specifications

Temperature range	
Cooling	5 °C to 20 °C
Freeze	-26 °C to -15 °C

Maximum ice cube quantity / 24 hours	
Freezer compartment	see type plate under "Freezing capacity .../ 24 h"

Maximum loading weight for the equipment			
Equipment	Appliance width 600 mm (see installation instructions, device dimensions)	Appliance width 700 mm (see installation instructions, device dimensions)	Appliance width 750 mm (see installation instructions, device dimensions)
Freezer section partial pull-out (see 9.2.1 Drawer on telescopic rails)	15 kg	22 kg	22 kg

Maximum loading weight for the bottle rack	
Bottle shelf	60 kg
Bottle rack with telescopic rails	25 kg

Ice cube production with IceMaker	
Ice cube production / 24 hours	At a temperature of -18 °C: 1.2 kg of ice cubes
maximum ice cube production / 24 hours	With the MaxIce function on: 1.5 kg of ice cubes

Lighting	
Class ¹	Light source
This product contains one or more energy efficiency class G light sources.	LED

¹ The appliance may contain light sources with different energy efficiency classes. The lowest energy efficiency class is indicated.

For appliances with a WiFi connection:

Frequency specification	
Frequency band	2.4 GHz
Maximum radiated power	< 100 mW
Purpose of the wireless equipment	Integration in the local WiFi network for data communication

11.2 Operating noises

The appliance makes different noises when it is on.

- At **higher temperatures** the appliance uses less energy but works for longer. It is **quieter**.
- At **lower temperatures** the food is cooled faster. It is **louder**.

Examples:

- Functions on (see 8.2 Appliance functions)
- Fan running
- Food recently added
- High ambient temperature
- Door open for a while

Noise	Possible cause	Type of noise
Bubbling and splashing	Coolant flowing into the cooling circuit.	Normal operating noise
Hissing	Coolant sprays into the cooling circuit.	Normal operating noise
Humming	The appliance is cooling. The volume depends on the cooling output.	Normal operating noise
Suction noises	Soft-closing door is being opened and closed.	Normal operating noise
Humming and rustling	The fan is running.	Normal operating noise
Clicking	Components are switched on and off.	Normal switching noise
Rattling or humming	Valves or flaps are working.	Normal switching noise

Noise	Possible cause	Type of noise	Lifting
Vibration	Improper setup	Defective noise	Level the appliance using the adjustable feet.
Rattling	Components, items inside the appliance	Defective noise	Secure components. Leave enough space between the items.

11.3 Technical fault

Your appliance is designed and built to ensure it works reliably and has a long service life. In the unlikely event that a fault occurs during operation, please check whether it is due to an operating error. If so, you will be charged for the callout and repair costs even if it falls within the warranty period.

You can fix the following faults yourself.

11.3.1 Appliance function

Defect	Cause	Remedy
The appliance is not working.	→ The appliance is not switched on.	▶ Switch the appliance on.
	→ The power plug is not properly plugged into the socket.	▶ Check the power plug.
	→ There is something wrong with the power outlet fuse.	▶ Check the fuse.
	→ Power cut	▶ Keep the appliance closed. ▶ Safeguarding food: Place cold packs on top of food or use another freezer if the power cut lasts longer. ▶ Do not re-freeze defrosted food,
	→ The IEC socket is not plugged into the appliance correctly.	▶ Check the IEC socket.
Temperature is not cold enough.	→ The appliance door is not closed properly.	▶ Close the appliance door.
	→ The ambient temperature is too high.	▶ Problem solution: (see 2.4 Appliance range of use) (see 1.2 Climate classes)
	→ The appliance was opened too many times or for too long.	▶ Wait to see if the required temperature corrects itself. If not, contact Customer Service. (see 11.4 Customer Service)
	→ Too much fresh food was placed inside without SuperFrost.	▶ Solution: (see SuperFrost)
	→ The temperature is set incorrectly.	▶ Turn down the temperature and check after 24 hours.
	→ The appliance is too close to a heat source (oven, radiator, etc).	▶ Move the appliance or the heat source.
The temperature shown on the display is higher than the actual temperature in the appliance.	→ Appliance door was open for a long time and the door alarm was triggered automatically. This causes the appliance to cool more vigorously.	▶ Close appliance door.
The door seal is defective or needs to be replaced for another reason.	→ The door seal can be replaced. It can be replaced without the need for special tools.	▶ Contact Customer Service. (see 11.4 Customer Service)
The appliance builds up too much ice or condensation.	→ The door seal may have slipped out of its groove.	▶ Check that the door seal is well fitted in the groove.
The exterior surfaces of the appliance are warm.*	→ The heat of the refrigeration circuit is used to avoid condensation.	▶ This is normal.

11.3.2 Features

Defect	Cause	Remedy
You cannot activate the IceMaker.	→ The appliance and therefore the IceMaker are not connected.	▶ Connect the appliance (see the Installation Guide).
The IceMaker is not producing ice cubes.	→ The IceMaker is not on.	▶ Activate the IceMaker.
	→ The drawer of the IceMakers is not connected properly.	▶ Push the drawer in correctly.

Shutting down

Defect	Cause	Remedy
	→ The water connection is not open.	▶ Open the water connection.
Mould on the wine bottles	→ Similar to other types of bearing, a slight layer of mould can form depending on the type of adhesive used for the label.	▶ Remove any adhesive residues.
The internal light does not come on.	→ The appliance is not switched on.	▶ Switch the appliance on.
	→ The door was open for longer than 15 minutes.	▶ Interior lighting switches off automatically after about 15 minutes when the door is open.
	→ The LED interior light is faulty or the lid is damaged.	▶ Contact Customer Service. (see 11.4 Customer Service)

11.4 Customer Service

First check whether you can rectify the fault yourself (see 11 Customer help) . If you cannot rectify the problem, contact Customer Service.

You can find the address in the enclosed brochure “Liebherr-Service” or at home.liebherr.com/service.



WARNING

Unprofessional repair!
Injuries.

- ▶ Have any repairs and action - not expressly specified - on the appliance and mains cable carried out by service personnel only. (see 10 Maintenance)
- ▶ A damaged mains cable may only be replaced by the manufacturer, the manufacturer’s Customer Service or a similarly qualified person.
- ▶ In the case of appliances with an IEC connector, the change may be made by the customer.

11.4.1 Contacting Customer Service

Make sure that the following appliance information is available:

- Appliance name (model and index)
- Service no. (Service)
- Serial no. (S no.)
- ▶ Call up the appliance information via the display. (see Device information)
- or-
- ▶ Refer to the type plate for appliance information. (see 11.5 Model plate)
- ▶ Note down the appliance information.
- ▶ Notify customer service: Report errors and the appliance information.
- ▶ This will help us to provide you with a faster, more accurate service.
- ▶ Follow further instructions from Customer Service.

11.5 Model plate

The model plate is behind the drawers on the inside of the appliance.

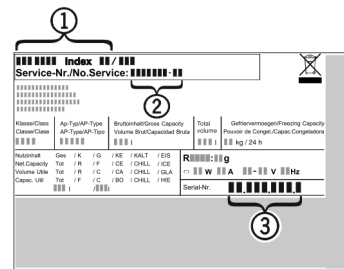

Fig. 159

- (1) Appliance description
- (2) Service no.
- (3) Serial no.
- ▶ Note the data on the model plate.

12 Shutting down

- ▶ Empty the appliance.
- ▶ Deactivate IceMaker. (see Deactivating the IceMaker and MaxIce)
- ▶ Switch off appliance. (see Switching the appliance off and on)
- ▶ Pull the mains plug out of the socket.
- ▶ Remove the IEC socket if required: Pull the IEC socket out of the appliance plug and move it to the left and right at the same time.
- ▶ Clean appliance. (see 10.4 Cleaning the appliance)
- ▶ Leave the door open, so that no unpleasant odours arise.

13 Disposal

Ensure that the following requirements are met:

- Meaning of the symbols on the appliance: are familiar. (see 1.14 Symbols on the appliance)
- Notes on disposal are familiar. (see 1.8 Disposal)

13.1 Preparing the appliance for disposal

- ▶ Shutting your appliance down. (see 12 Shutting down)

13.2 Disposing of the appliance in an environmentally friendly manner



WARNING

Leaking coolant and oil!

Fire. The coolant contained in the appliance is eco-friendly, but also flammable. The oil contained in the appliance is flammable. Escaping coolant and oil can ignite if the concentration is high enough and in contact with an external heat source.

- ▶ Do not damage the pipelines of the coolant circuit and the compressor.
-
- ▶ Observe the notes on transporting the appliance. (see 3.6 Transporting the appliance)
 - ▶ Remove the appliance without damaging it.
 - ▶ Dispose of appliance according to specifications.

Scan QR Code and find
digital operating and
installation instructions.



home.liebherr.com

20260407

7083938-00

Liebherr-Hausgeräte Marica E00D

Bezirk Plovdiv
4202 Radinovo
Bulgarien