Extend what matters.

Big on comfort. Big on capacity. Discover our new extra-high and extra-wide fully integrated appliances.



LIEBHERR

Extend what matters.

We listened to how people really live. So we focussed on what really matters – not just specifications, but everyday life: long-lasting freshness that gives you more time to enjoy, design that brings a sense of calm, energy efficiency you can feel good about for decades.

That's why we've extended our fully integrated portfolio, introducing new extra-high and extra-wide appliances designed for different ways of living.

Different lives. Different needs. One promise: appliances designed around what matters most built with the German precision that matters most to us.



Regular
Fridge-freezer

XL
Refrigerator

XXL
Fridge-freezer



ICBNdi 5163 ◊ Prime series

IRBbi 5650 ◊ Prime series

ICBNbi 7663 ◊ Prime series



XXL Fully integrated fridge-freezer

When life gets bigger, the fridge should too.

Our new XXL fully integrated fridge-freezer is the world's first to feature an IceMaker and multiple BioFresh safes, bringing outstanding design, an extra-class energy rating, and made-in-Germany quality to the large-capacity segment.

Designed for homes that say yes to lively weekday family life and long, laughter-filled dinners with friends.

Yes to generous market hauls that keep your customers satisfied – thanks to extra-wide BioFresh safes keeping food fresh for up to 5x longer.

Yes to friends who always bring a plus one – with the automatic IceMaker keeping drinks perfectly chilled and the evening flowing.

The best moments can't be planned. Only extended.

Extend what matters.

Made in Germany



Worlds first



Bio Fresh

Glass & Steel-look Interior

Ice Maker

← 75 →

↑ 194 ↓

ICBNbi 7663 Prime series



Ice Maker

IceMaker with fixed water connection

The IceMaker produces up to 1.5 kg of ice per day. The extra-large drawer stores additional capacity when needed, while a divider allows flexible organisation based on demand.



Soft System

SoftSystem

With the SoftSystem, the fridge door closes softly and safely, and in a way which is pleasantly quiet and light. Bottles stored in the inside door remain securely in place.



Extra-wide door shelves

The extra-wide door with extra-large door shelves provides ample storage for eggs, bottles and smaller items.

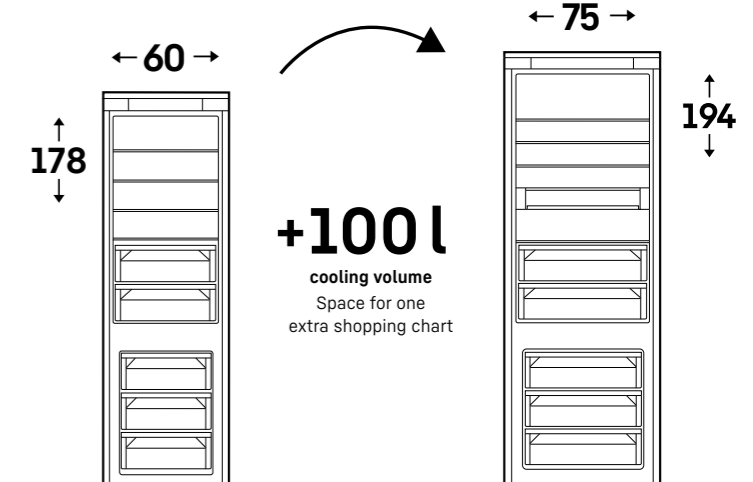

XXL Fully integrated fridge-freezer

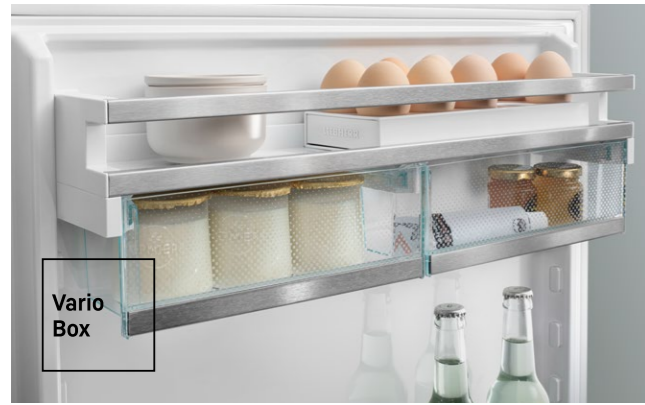

Vario Box

VarioBox

There's plenty of room for all those small but essential items – thanks to the extra-wide VarioBoxes. They help to keep small items neatly organised.



No Frost

NoFrost

The extra-large NoFrost drawer offers generous space for frozen goods – but none for frost. NoFrost reliably prevents unwanted icing in the freezer compartment.



Bio Fresh

BioFresh Fruit & Vegetable safe

With temperatures close to 0°C and a tight seal that maintains high humidity, the extra-wide Fruit & Vegetable safe creates the ideal environment – keeping unpackaged fruit and vegetables fresh for up to 5x times longer.

BioFresh Meat & Dairy safe

The extra-spacious BioFresh Meat & Dairy safe maintains temperatures close to 0°C, creating ideal conditions for even the most delicate foods. Best of all, it comes perfectly preset for immediate use.



Light Tower

Glass & Steel-look Interior

Vario Safe



Flexible bottle shelf

The flexible bottle shelf creates space while preserving storage area: Sliding the glass shelf creates room for bottles while the remaining surface stays usable. If required, the glass shelf can be fully removed – creating additional space.

LightTower

The LightTower creates elegant lighting accents and showcases food with refined clarity. Even when fully loaded, the interior remains evenly and generously illuminated.

Steel-look rear wall

The elegant Steel-look rear wall delivers a refined look and feel. Its surface is food-safe and hygienic, supporting optimal storage conditions.

XL Fully integrated refrigerator

When design leads, calm follows.

A calm kitchen sets the tone for an aspirational lifestyle. Introducing the first XL fully integrated refrigerator for a 194 cm niche – made in Germany, featuring an outstanding energy efficiency class B rating and three BioFresh safes that preserve freshness for up to 5x longer.

Hidden behind the cabinetry, this appliance features the elegantly designed LightTower, illuminating every shelf.

This extra-tall appliance blends seamlessly into any kitchen, allowing your customers' spaces to breathe.

Extend what matters.

Worlds first



Light Tower

Glass & Steel-look Interior

Soft System

Bio Fresh



IRBbi 5650 ◯ Prime series

G Made in Germany

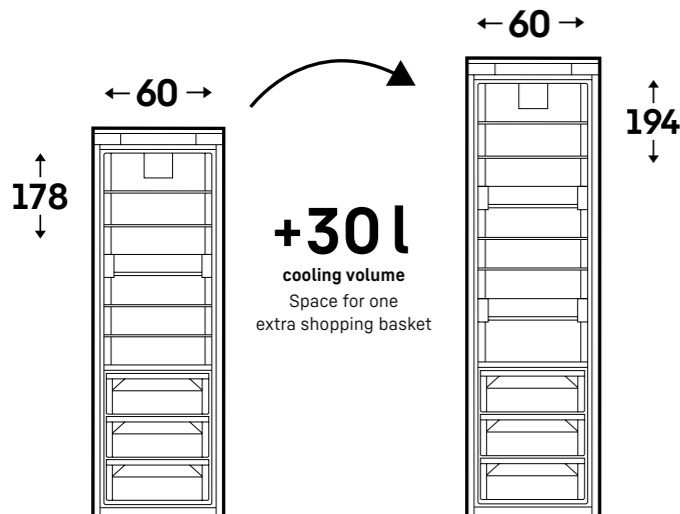

Two VarioSafes

For neatly organised storage of small items such as yoghurt pots, jam jars or tubes, the two VarioSafes offer both order and flexibility. The VarioSafes are not only height-adjustable in two stages, but can also be placed wherever it suits you best within the refrigerator.



Bio Fresh

Perfect food storage depends not only on the ideal temperature, but also on optimal humidity. At Liebherr, we have developed innovative freshness technologies that keep food fresh for up to 5x longer. Our new XL fully integrated refrigerators feature three BioFresh safes for optimum storage conditions.

Product detail and installation

Experience cooling solutions engineered for modern living. Our XL and XXL appliances combine generous capacity with advanced freshness technologies to keep ingredients fresher for longer.

Discover each model's key highlights, precise product data, and installation drawings to help you plan your perfect kitchen with confidence and clarity.



XXL Fixed door

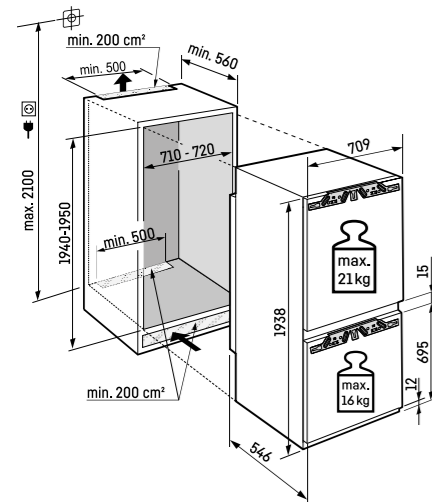

XXL Fixed door and water connection

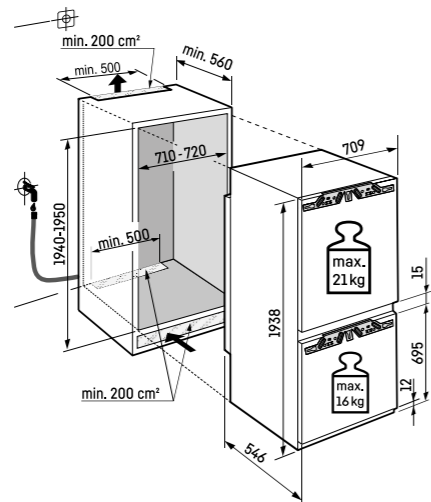

XXL Sliding door

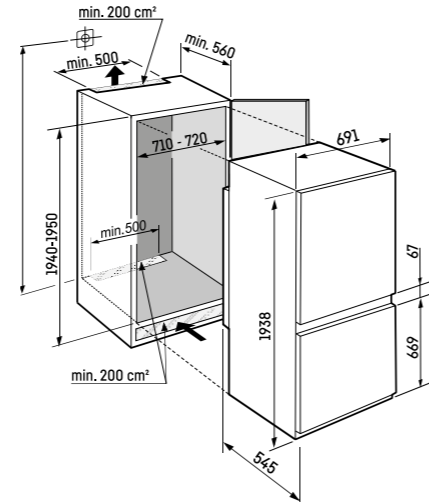

XL Fixed door

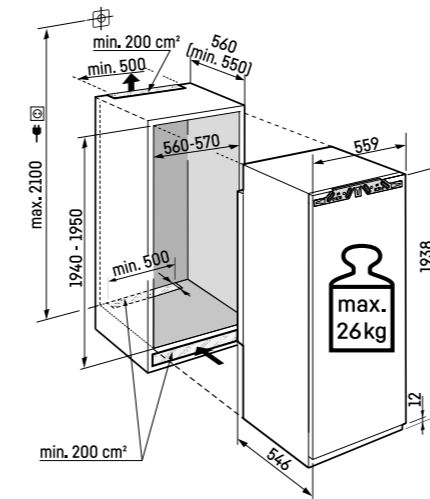

Appliances can be connected to the Smart Home system ex works. All other appliances can be retro-fitted with the SmartDeviceBox - sold separately.

XL Fixed door



IRBci 5620 Plus

Energy efficiency class:	
Energy consumption per year / 24 h:	102 / 0.279 kWh
Total volume ¹ :	323l
Climate rating:	SN-T
Aperture dimensions in cm (h / w / d):	194 - 195 / 56 - 57 / 55

IRBbi 5650 Prime

Energy efficiency class:	
Energy consumption per year / 24 h:	81 / 0.221 kWh
Total volume ¹ :	325l
Climate rating:	SN-T
Aperture dimensions in cm (h / w / d):	194 - 195 / 56 - 57 / 55

XXL Fixed door



ICNc 7603 Pure

Energy efficiency class:	
Energy consumption per year / 24 h:	160 / 0.438 kWh
Total volume ¹ :	359l
Climate rating:	SN-T
Aperture dimensions in cm (h / w / d):	194 - 195 / 71 - 72 / 56

Also available as a fixed-door appliance in energy efficiency class D (ICNd 7603) or as a sliding-door model, also in energy efficiency class D (ICNsD 7603).

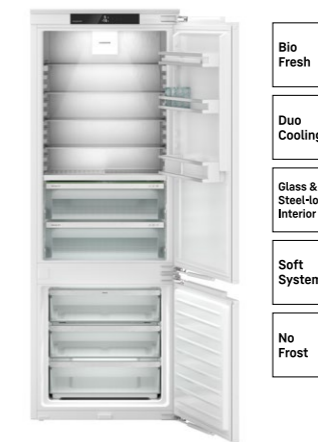

ICBnc 7623 Plus

Energy efficiency class:	
Energy consumption per year / 24 h:	178 / 0.487 kWh
Total volume ¹ :	347l
Climate rating:	SN-ST
Aperture dimensions in cm (h / w / d):	194 - 195 / 71 - 72 / 56

Also available as a sliding-door model in energy efficiency class D: ICBNSd 7623.

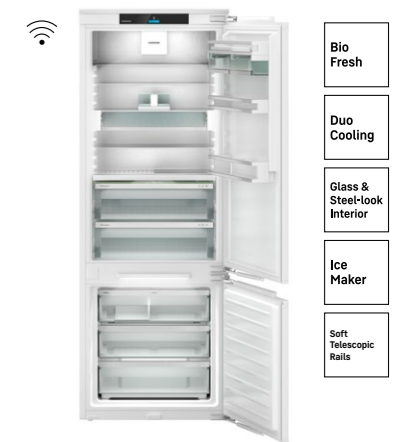

ICBnbi 7663 Prime

Energy efficiency class:	
Energy consumption per year / 24 h:	142 / 0.389 kWh
Total volume ¹ :	349l
Climate rating:	SN-ST
Aperture dimensions in cm (h / w / d):	194 - 195 / 71 - 72 / 56

¹ Total volume: In accordance with Regulation EU 2019/2016 we indicate the total volume to the nearest integer (rounded off) and the volume of the frozen compartments and refrigeration compartments to one place after the decimal point. According to (EU) 2017/1369 6a.



Subject to technical changes, errors and deviations in image and text.
Deviations in colour are due to printing processes. Products and their details are staged for advertising purposes. The models shown are not available in all countries. For the latest available data, go to home.liebherr.com.
Printed in Germany by Holzer Druck und Medien. 7904 672-00 / 03.26 / EN

