L 538 Speeder

LIEBHERR

Wheel loader



Generation
8

Diesel engine
Stage V

Tipping load
9,400 kg – 9,900 kg

Technical data

Diesel engine

Diesel engine	6068HB551	
Design	Water-cooled turbocharged in-series engine with cooled exhaust gas recirculation	
Cylinder inline	6	
Fuel injection process	Electronic Common Rail high-pressure injection	
Output to	kW / HP	181/246
ISO 9249 - SAE J1349	at RPM	2,000
Rated output to		
ISO 14396 / ECE-R.120	kW / HP	168/228
Nominal speed	at RPM	2,200
Max. torque to	Nm	970
ISO 14396	at RPM	1,600
Displacement	litres	6.8
Bore / Stroke	mm	106 / 127
Stage V		
Harmful emissions values	According to regulation (EU) 2016/1628	
Emission control	SCR technology and closed diesel particle filter system	
Air cleaner system	Dry type filter with main and safety element, pre-cleaner, service indicator on the Liebherr display	
Electrical system		
Operating voltage	V	24
Battery	Ah	2 x 135
Alternator	V/A	24 / 100
Starter	V/kW	24 / 7.8

Driveline

Continuous hydrostatic driveline		
Design	Swash plate type variable flow pump and two variable axial piston motors in closed loop circuit and axle transfer case. Direction of travel is reversed by changing the flow-direction of the variable-displacement pump	
Filtration	Suction return line filter for closed circuit	
Control	By travel and inching pedal. The inching pedal makes it possible to control the tractive and thrust forces steplessly at full engine speed. The Liebherr control lever is used to control forward and reverse travel	
Travel speed range	Speed range 1	0 - 8 km/h
	Speed range A1 - 2	0 - 16 km/h
	Speed range A1 - 3	0 - 40 km/h
	orward and reverse	
	Speeds quoted apply with the tyres indicated as standard on loader model.	

Brakes

Wear-free service brake	Self-locking of the hydrostatic driveline (acting on all four wheels) and additional pump-accumulator brake system with wet multi-disc brakes located in the differential housing (two separate brake circuits)
Parking brake	Electro-hydraulically actuated spring-loaded disc brake system on the front axle

The braking system meets the requirements of the ISO 3450.

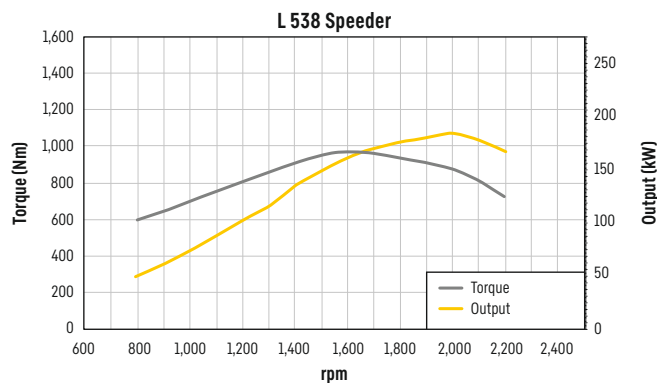

Axles

Four-wheel drive	
Front axle	Fixed
Rear axle	Centre pivot, with 10° oscillating angle to each side
Height of obstacles which can be driven over	mm 470
Differentials	with all four wheels remaining in contact with the ground Automatic limited-slip differentials with 45% locking action in both axles
Reduction gear	Planetary final drive in wheel hubs
Track width	1,900 mm with all types of tyres

Steering

Design	"Load-sensing" swash plate type variable flow pump with pressure cut-off and flow control. Central pivot with two double-acting steering cylinders
Angle of articulation	40° to each side
Emergency steering	Electro-hydraulic emergency steering system

Attachment hydraulics

Design	"Load-sensing" variable axial piston pump with output and flow control, and pressure cut-off in the control block
Cooling	Hydraulic oil cooling using thermostatically controlled fan and oil cooler
Filtration	Return line filter in the hydraulic reservoir
Control	Liebherr control lever, electro-hydraulically operated
Lifting function	Lifting, neutral, lowering Auto lifting and lowering using Liebherr control lever, float position using Liebherr control lever
Tilt function	Tilt back, neutral, dump Automatic bucket return-to-dig for tilting in and out using Liebherr control lever
Max. flow	l/min. 200
Max. pressure	bar 350

Attachment

Geometry	Powerful, optimised z-bar kinematics with one tilt cylinder, optional hydraulic quick coupler
Bearings	Sealed
Cycle time at nominal load	ZK
Lifting	s 5.5
Dumping	s 1.9
Lowering (empty)	s 4.9

Operator's cab

Design	Elastic mounted, noise-proof cab ROPS roll over protection per EN ISO 3471 / EN 474-1 FOPS falling objects protection per EN ISO 3449 / EN 474-1, Cat. II Driver's cab door with 105° opening angle and opening window with 5° gap opener or 170° opening, right side sliding side window, front windscreen made of laminated safety glass, green tinted as standard, side panels with single-pane safety glass ESG, green tinted, heated rear window ESG. Continuously adjustable steering column
Liebherr operator's seat	6 way adjustable, vibration-damped operator's seat "Comfort" with seat, depth and incline adjustment as standard (air-cushioned with seat heating adjustable to operator's weight), Liebherr control lever mounted into the operator's seat as standard
Cab heating and ventilation	2-level air control, cooling water heating, defroster and air conditioning via manual nozzle position or electronic valve control for head and front area, as well as electronic fresh / recirculated air control, electrically heated rear window, filter system with pre-filter, fresh air filter and recirculated air filter, easily replaced, air condition / automatic air conditioning system with new improved cooling output optional
Vibration emissions	
Hand / arm vibrations	≤ 2.5 m/s ² , according with ISO 5349-1:2001
Whole-body vibrations	≤ 0.5 m/s ² , complies with technical report ISO/TR 25398:2006
Measuring inaccuracy	According with standard EN 12096:1997

Sound level

Sound pressure level to ISO 6396		
L _{PA} (inside cab)	dB(A)	69
Sound power level to 2000/14/EG		
L _{WA} (surround noise)	dB(A)	104

Capacities

Fuel tank (plastic design)	l	205
Fuel tank (steel version, optional)	l	300
DEF tank	l	20
Engine oil (inclusive filter change)	l	23.5
Transmission	l	2.5
Coolant	l	26.5
Front axle / wheel hubs	l	19 / 3.5
Rear axle / wheel hubs	l	19 / 3.5
Hydraulic tank	l	95
Hydraulic system, total	l	180

Dimensions

Loading bucket

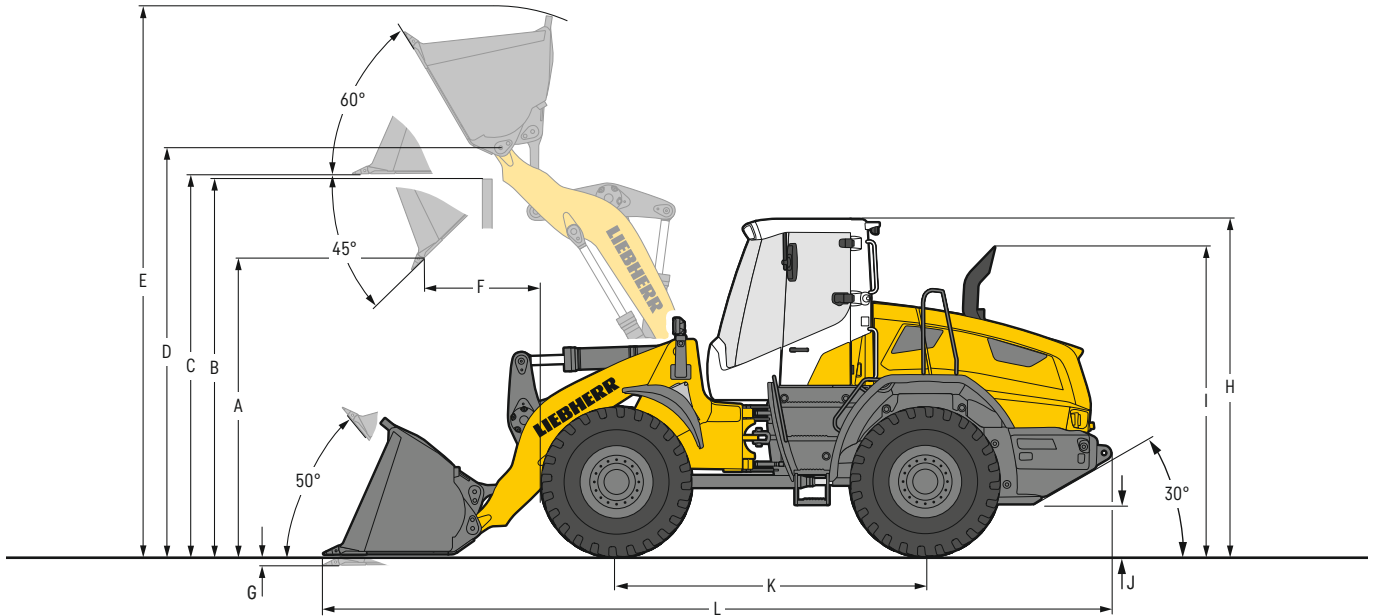

Loading bucket

	ZK	ZK-QH
Geometry	T	T
Cutting tools	T	T
Lift arm length	mm	2,650
Bucket capacity according to ISO 7546**	m ³	2.6
Specific material density	t/m ³	1.8
Bucket width	mm	2,720
A Dumping height at max. lift height and 45° discharge	mm	2,960
B Dump-over height	mm	3,540
C Max. height of bucket bottom	mm	3,720
D Max. height of bucket pivot point	mm	3,980
E Max. operating height	mm	5,270
F Reach at max. lift height and 45° discharge	mm	1,085
G Digging depth	mm	100
H Height above operator's cab ¹⁾	mm	3,250
I Height above exhaust	mm	2,950
J Ground clearance	mm	430
K Wheelbase	mm	3,025
L Overall length	mm	7,630
Turning circle radius over outside bucket edge	mm	6,140
Breakout force (SAE)	kN	125
Tipping load, straight*	kg	11,500
Tipping load, fully articulated*	kg	9,900
Operating weight*	kg	14,850
Tyre size	20.5R25 L3	

* The figures shown include the above tyres, all lubricants, a full fuel tank, the ROPS/FOPS cab and the operator. Different tyres and optional equipment will change the operating weight and tipping load. (Tipping load, fully articulated according to ISO 14397-1)

** Actual bucket capacity may be approx. 10% larger than the calculation according to ISO 7546 standard. The degree to which the bucket can be filled depends on the material - see page 11.

¹⁾ With the optional "comfort safety door (can be opened 180°)", the "H" value increases by 130 mm when door is open.

ZK = Z-bar linkage

ZK-QH = Z-bar linkage incl. quick hitch

T = Welded-on tooth holder with add-on teeth

Dimensions

High lift arm/standard bucket

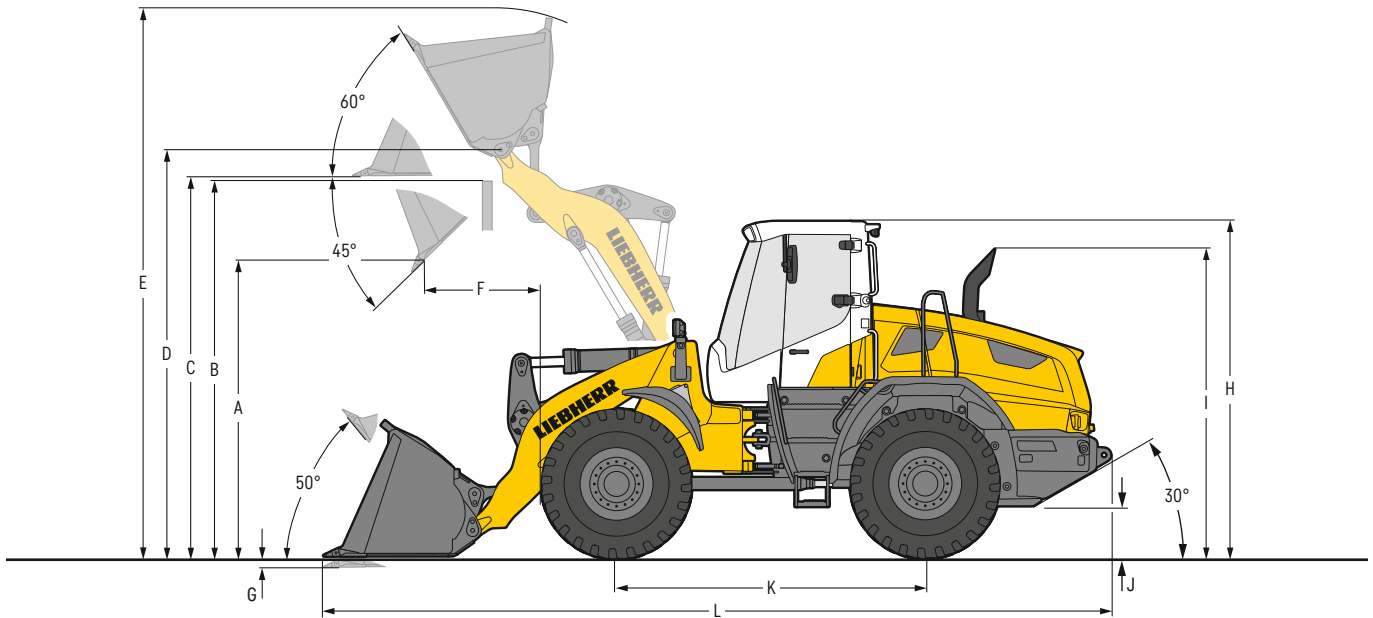

Loading bucket

	ZK	ZK-QH
Geometry	T	T
Cutting tools	T	T
Lift arm length	3,000	3,000
Bucket capacity according to ISO 7546**	2.4	2.2
Specific material density	1.6	1.6
Bucket width	2,520	2,520
A Dumping height at max. lift height and 45° discharge	3,500	3,415
B Dump-over height	4,070	4,070
C Max. height of bucket bottom	4,260	4,260
D Max. height of bucket pivot point	4,520	4,520
E Max. operating height	5,820	5,870
F Reach at max. lift height and 45° discharge	935	1,010
G Digging depth	120	120
H Height above operator's cab ¹⁾	3,250	3,250
I Height above exhaust	2,950	2,950
J Ground clearance	430	430
K Wheelbase	3,025	3,025
L Overall length	8,080	8,200
Turning circle radius over outside bucket edge	6,260	6,300
Breakout force (SAE)	130	120
Tipping load, straight*	9,600	8,900
Tipping load, fully articulated*	8,200	7,600
Operating weight*	14,960	15,360
Tyre size	20.5R25 L3	

* The figures shown include the above tyres, all lubricants, a full fuel tank, the ROPS/FOPS cab and the operator. Different tyres and optional equipment will change the operating weight and tipping load. (Tipping load, fully articulated according to ISO 14397-1)

** Actual bucket capacity may be approx. 10% larger than the calculation according to ISO 7546 standard. The degree to which the bucket can be filled depends on the material - see page 11.

¹⁾ With the optional "comfort safety door (can be opened 180°)", the "H" value increases by 130 mm when door is open.

ZK = Z-bar linkage

ZK-QH = Z-bar linkage incl. quick hitch

T = Welded-on tooth holder with add-on teeth

Attachment

Light material bucket

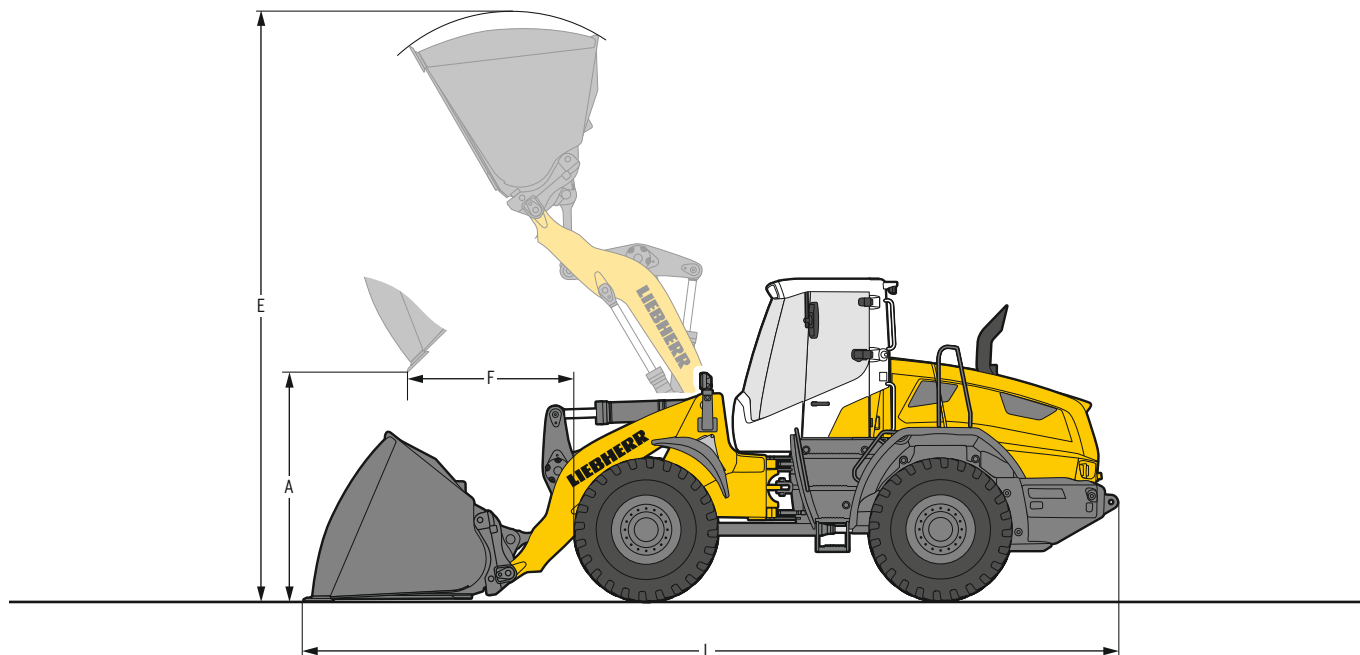

Heavy material density

Geometry		ZK	ZK-QH
Cutting tools		BOCE	BOCE
Bucket capacity	m ³	4.0	4.0
Specific material density	t/m ³	1.05	1.0
Bucket width	mm	2,700	2,700
A Dumping height at max. lift height	mm	2,595	2,520
E Max. operating height	mm	5,510	5,610
F Reach at maximum lift height	mm	1,420	1,490
L Overall length	mm	7,970	8,080
Tipping load, straight*	kg	10,900	10,300
Tipping load, fully articulated*	kg	9,300	8,900
Operating weight*	kg	15,100	15,520
Tyre size		20.5R25 L3	



Light material density

Geometry		ZK-QH
Cutting tools		BOCE
Bucket capacity	m ³	6.5
Specific material density	t/m ³	0.5
Bucket width	mm	2,700
A Dumping height at max. lift height	mm	2,190
E Max. operating height	mm	6,080
F Reach at maximum lift height	mm	1,830
L Overall length	mm	8,550
Tipping load, straight*	kg	9,800
Tipping load, fully articulated*	kg	8,400
Operating weight*	kg	15,920
Tyre size		20.5R25 L3

* The figures shown include the above tyres, all lubricants, a full fuel tank, the ROPS / FOPS cab and the operator. Different tyres and optional equipment will change the operating weight and tipping load. (Tipping load, fully articulated according to ISO 14397-1)

ZK = Z-bar linkage

ZK-QH = Z-bar linkage incl. quick hitch

BOCE = Bolt-on cutting edge

Attachment

High lift arm/light material bucket

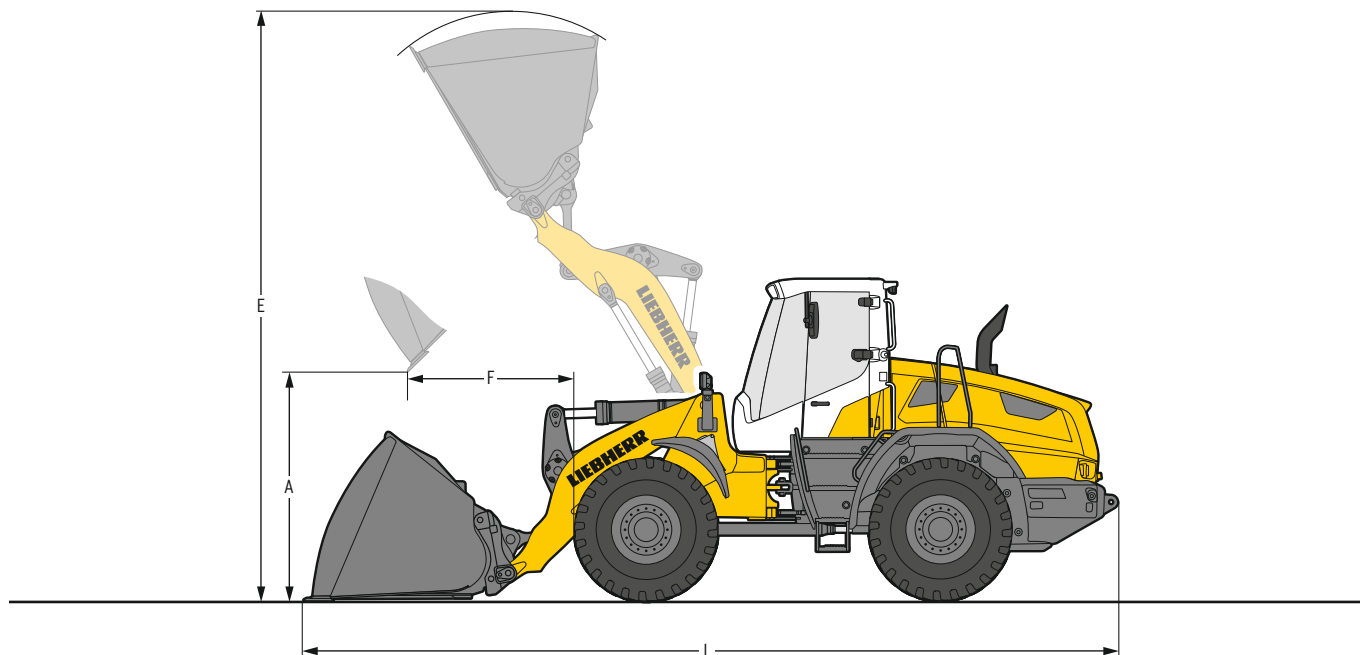

Heavy material density

Geometry		ZK	ZK-QH
Cutting tools		BOCE	BOCE
Bucket capacity	m ³	4.0	4.0
Specific material density	t/m ³	0.85	0.8
Bucket width	mm	2,700	2,700
A Dumping height at max. lift height	mm	3,135	3,060
E Max. operating height	mm	6,060	6,160
F Reach at maximum lift height	mm	1,275	1,340
L Overall length	mm	8,420	8,530
Tipping load, straight*	kg	9,000	8,500
Tipping load, fully articulated*	kg	7,700	7,200
Operating weight*	kg	15,300	15,730
Tyre size		20.5R25 L3	



Light material density

Geometry		ZK-QH
Cutting tools		BOCE
Bucket capacity	m ³	5.5
Specific material density	t/m ³	0.5
Bucket width	mm	2,700
A Dumping height at max. lift height	mm	2,850
E Max. operating height	mm	6,440
F Reach at maximum lift height	mm	1,555
L Overall length	mm	8,830
Tipping load, straight*	kg	8,100
Tipping load, fully articulated*	kg	6,800
Operating weight*	kg	15,970
Tyre size		20.5R25 L3

* The figures shown include the above tyres, all lubricants, a full fuel tank, the ROPS / FOPS cab and the operator. Different tyres and optional equipment will change the operating weight and tipping load. (Tipping load, fully articulated according to ISO 14397-1)

ZK = Z-bar linkage

ZK-QH = Z-bar linkage incl. quick hitch

BOCE = Bolt-on cutting edge

Attachment

High-Dump bucket

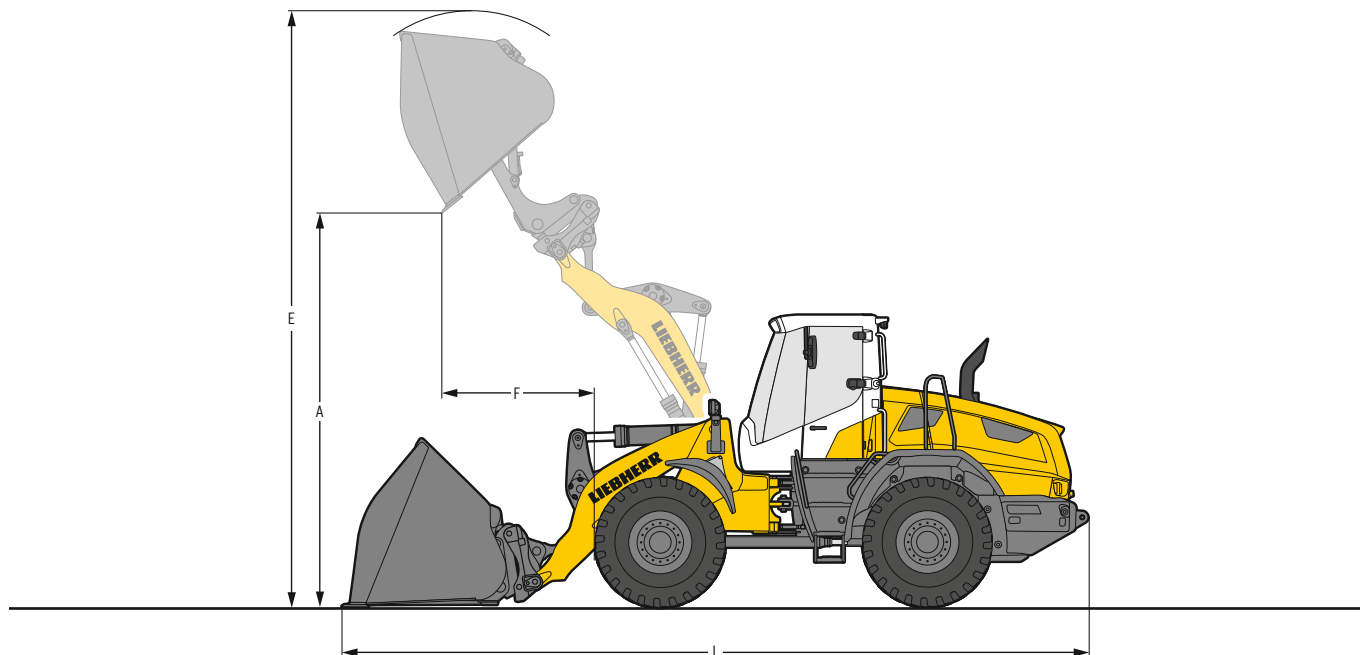

Heavy material density

Geometry		ZK	ZK-QH
Cutting tools		BOCE	BOCE
Bucket capacity	m ³	3.5	3.5
Specific material density	t/m ³	1.1	1.05
Bucket width	mm	2,700	2,700
A Dumping height at max. lift height	mm	4,550	4,680
E Max. operating height	mm	6,360	6,550
F Reach at maximum lift height	mm	1,430	1,470
L Overall length	mm	8,060	8,140
Tipping load, straight*	kg	10,100	9,600
Tipping load, fully articulated*	kg	8,600	8,100
Operating weight*	kg	15,750	16,100
Tyre size		20.5R25 L3	



Light material density

Geometry		ZK-QH
Cutting tools		BOCE
Bucket capacity	m ³	6.0
Specific material density	t/m ³	0.5
Bucket width	mm	2,700
A Dumping height at max. lift height	mm	4,385
E Max. operating height	mm	6,910
F Reach at maximum lift height	mm	1,750
L Overall length	mm	8,510
Tipping load, straight*	kg	9,500
Tipping load, fully articulated*	kg	8,000
Operating weight*	kg	16,250
Tyre size		20.5R25 L3

* The figures shown include the above tyres, all lubricants, a full fuel tank, the ROPS / FOPS cab and the operator. Different tyres and optional equipment will change the operating weight and tipping load. (Tipping load, fully articulated according to ISO 14397-1)

ZK = Z-bar linkage

ZK-QH = Z-bar linkage incl. quick hitch

BOCE = Bolt-on cutting edge

Attachment

High lift arm/high dump bucket

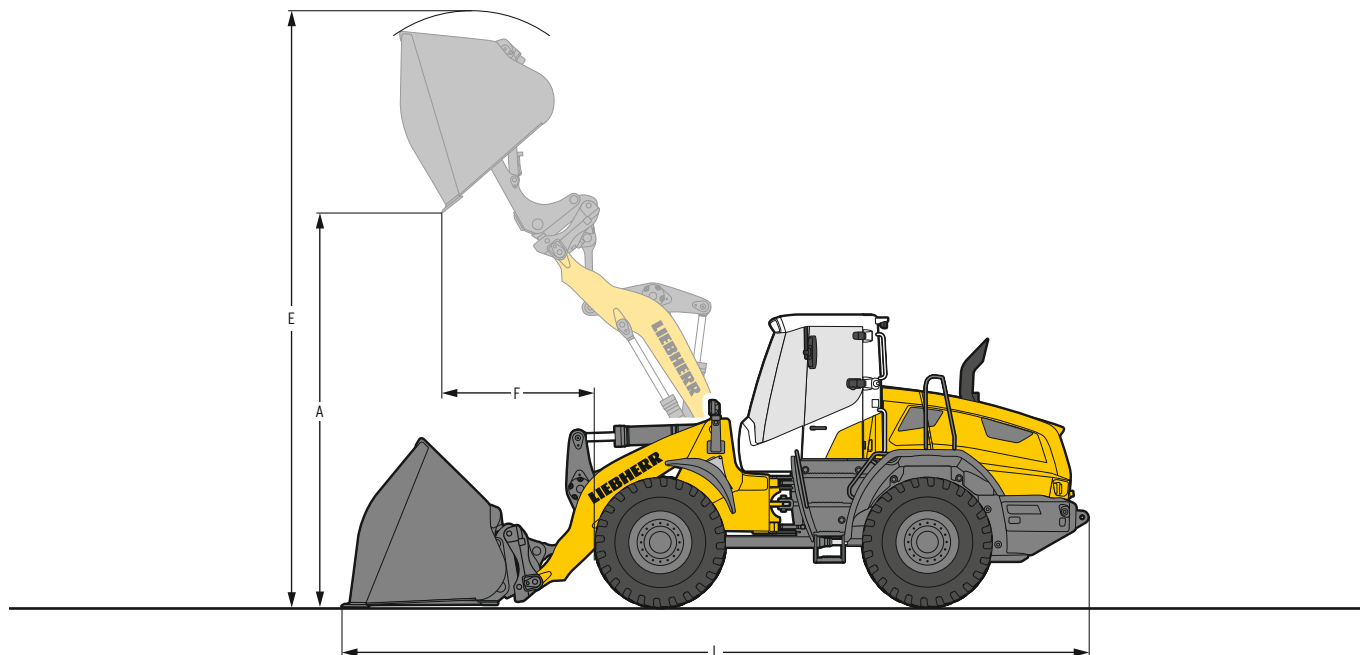

Heavy material density

Geometry		ZK	ZK-QH
Cutting tools		BOCE	BOCE
Bucket capacity	m ³	3.5	3.5
Specific material density	t/m ³	0.85	0.8
Bucket width	mm	2,700	2,700
A Dumping height at max. lift height	mm	5,090	5,220
E Max. operating height	mm	6,900	7,090
F Reach at maximum lift height	mm	1,285	1,325
L Overall length	mm	8,490	8,580
Tipping load, straight*	kg	8,300	7,800
Tipping load, fully articulated*	kg	7,000	6,500
Operating weight*	kg	15,950	16,300
Tyre size		20.5R25 L3	



Light material density

Geometry		ZK-QH
Cutting tools		BOCE
Bucket capacity	m ³	5.0
Specific material density	t/m ³	0.5
Bucket width	mm	2,700
A Dumping height at max. lift height	mm	5,000
E Max. operating height	mm	7,300
F Reach at maximum lift height	mm	1,510
L Overall length	mm	8,825
Tipping load, straight*	kg	7,800
Tipping load, fully articulated*	kg	6,500
Operating weight*	kg	16,350
Tyre size		20.5R25 L3

* The figures shown include the above tyres, all lubricants, a full fuel tank, the ROPS / FOPS cab and the operator. Different tyres and optional equipment will change the operating weight and tipping load. (Tipping load, fully articulated according to ISO 14397-1)

ZK = Z-bar linkage

ZK-QH = Z-bar linkage incl. quick hitch

BOCE = Bolt-on cutting edge

Attachment

Fork carrier and fork

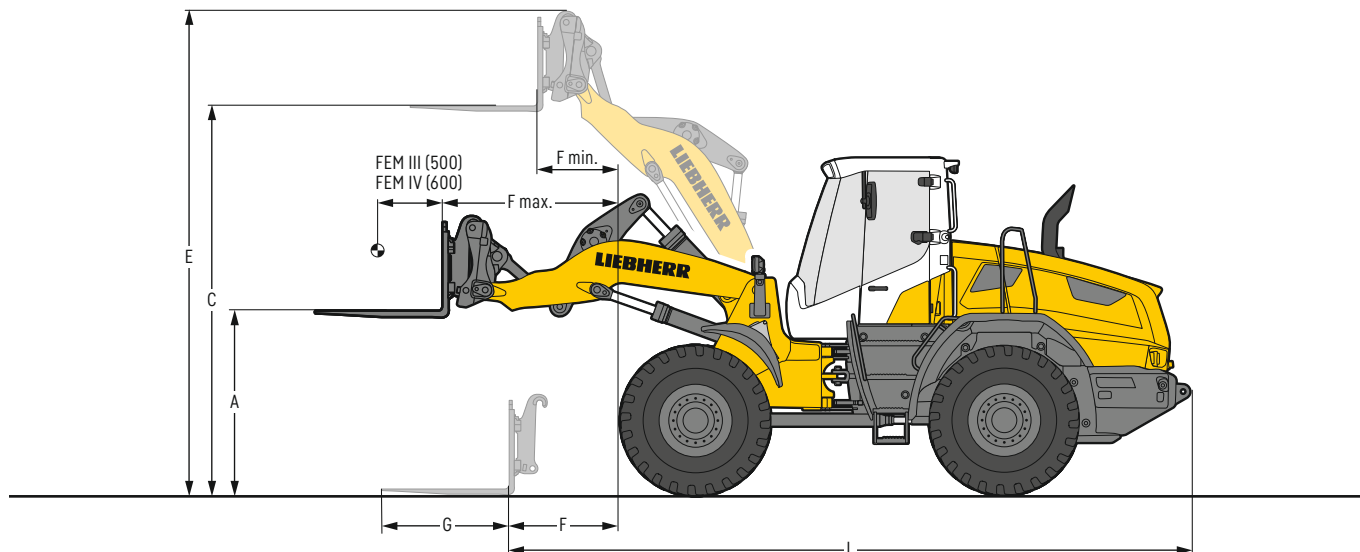

Fork carrier and fork

		STD	HL	STD	HL
Fork		FEM III	FEM III	FEM IV	FEM IV
Geometry		ZK-QC	ZK-QC	ZK-QC	ZK-QC
Lift arm length	mm	2,650	3,000	2,650	3,000
A Lifting height at max. reach	mm	1,780	1,780	1,740	1,740
C Max. lifting height	mm	3,780	4,310	3,740	4,270
E Max. operating height	mm	4,705	5,250	4,740	5,285
F Reach at loading position	mm	1,070	1,510	1,090	1,530
F max. Max. reach	mm	1,710	2,050	1,690	2,030
F min. Reach at max. lifting height	mm	790	650	770	630
G Fork length	mm	1,200	1,200	1,500	1,500
L Length - basic machine	mm	6,670	7,120	6,700	7,140
Tipping load, straight*	kg	8,300	7,150	7,900	6,800
Tipping load, fully articulated*	kg	7,190	6,150	6,780	5,780
Recommended payload for uneven ground = 60% of tipping load, articulated ¹⁾	kg	4,300	3,650	4,000	3,450
Recommended payload for smooth surfaces = 80% of tipping load, articulated ¹⁾	kg	5,000	4,900	5,400	4,600
Operating weight*	kg	14,680	14,870	14,920	15,130
Tyre size		20.5R25 L3		20.5R25 L3	

* The figures shown include the above tyres, all lubricants, a full fuel tank, the ROPS/FOPS cab and the operator. Different tyres and optional equipment will change the operating weight and tipping load. (Tipping load, fully articulated according to ISO 14397-1)

¹⁾ According to EN 474-3

STD = Standard lift arm length

HL = High Lift

ZK-QH = Z-bar linkage incl. quick hitch

Bucket selection

L 538 Speeder

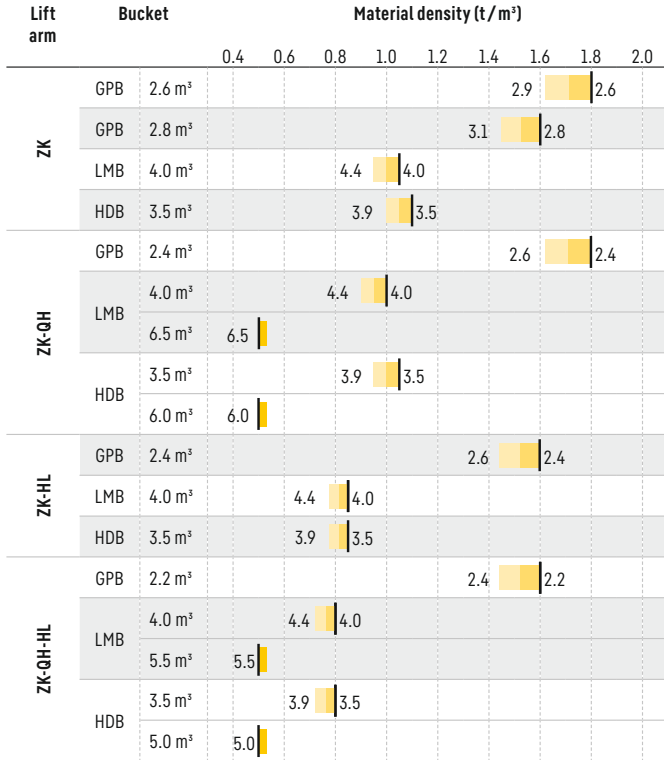

Bucket filling factor

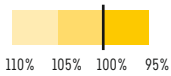

Lift arm

ZK	Z-bar linkage, standard lift arm length
ZK-QH	Z-bar linkage with quick hitch, standard lift arm length
ZK-HL	Z-bar linkage, High Lift
ZK-QH-HL	Z-bar linkage, with quick hitch, High Lift

Bucket

GPB	General purpose bucket (Excavation bucket)
LMB	Light material bucket
HDB	High-dump bucket

Tipping load



What is tipping load?

Load at centre of gravity of working equipment, so that the wheel loader just begins to tip over the front axle. This is the most unfavourable static-load position for the wheel loader. Lifting arms horizontal, wheel loader fully articulated at centre pivot.

Pay load.

The pay load must not exceed 50% of the tipping load when articulated. This is equivalent to a static stability-margin factor of 2.0.

Bucket capacity.

The bucket volume is determined from the pay load.

$$\text{Pay load} = \frac{\text{Tipping load, articulated}}{2}$$

$$\text{Bucket capacity} = \frac{\text{Pay load (t)}}{\text{Specific bulk weight of material (t/m}^3\text{)}}$$

Bulk material densities and bucket filling factors

		t/m ³	%			t/m ³	%			t/m ³	%
Gravel	moist	1.9	105	Earth	dry	1.3	115	Glass waste	broken	1.4	100
	dry	1.6	105		wet excavated	1.6	110		solid	1.0	100
	crushed stone	1.5	100	Topsoil		1.1	110	Compost	dry	0.8	105
Sand	dry	1.5	105	Basalt		1.95	100		wet	1.0	110
	wet	1.9	110	Granite		1.8	95	Wood chips / Saw dust		0.5	110
Gravel and Sand	dry	1.7	105	Sandstone		1.6	100	Paper	shredded / loose	0.6	110
	wet	2.0	100	Slate		1.75	100		recovered paper / cardboard	1.0	110
Sand / Clay		1.6	110	Bauxite		1.4	100	Coal	heavy material density	1.2	110
Clay	natural	1.6	110	Limestone		1.6	100		light material density	0.9	110
	dry	1.4	110	Gypsum	broken	1.8	100	Waste	domestic waste	0.5	100
Clay / Gravel	dry	1.4	110	Coke		0.5	110		bulky waste	1.0	100
	wet	1.6	100	Slag	broken	1.8	100				

Tyres



Tyre types

	Size and tread code		Change of operating weight kg	Width over tyres mm	Change in vertical dimensions* mm	Use
L 538 Speeder						
Bridgestone	20.5R25 VJT	L3	17	2,480	8	Bulk material (firm ground conditions)
Continental	20.5R25 EM-Master	L3	156	2,480	26	Bulk material (firm ground conditions)
Goodyear	20.5R25 TL-3A+	L3	156	2,500	11	Sand, Gravel, Earthworks, Clay (all ground conditions)
Goodyear	20.5R25 RT-3B	L3	11	2,490	16	Gravel (all ground conditions)
Michelin	20.5R25 XTLA	L2	- 121	2,510	- 7	Gravel, Earthworks, Clay (all ground conditions)
Michelin	20.5R25 XHA2	L3	0	2,480	0	Sand, Gravel (all ground conditions)
Michelin	620/70R26 CereXBib 2		- 364	2,620	11	Green area (agricultural tractor)
Michelin	620/75R26 MegaXBib		- 318	2,600	68	Green area (agricultural tractor)
Michelin	750/65R26 MegaXBib		- 22	2,850	81	Green area (agricultural tractor)
Mitas	750/65R26 SFT		- 62	2,880	76	Green area (agricultural tractor)
Nokian	20.5R25 Hakkapeliitta	L2	- 114	2,490	6	Winter tyres, Gravel, Asphalt (all ground conditions)
Trelleborg	620/75R26 TM2000		- 153	2,640	72	Green area (agricultural tractor)

* The stated values are theoretical and may deviate in practice.

Before operating the vehicle with tyre foam filling or tyre protection chains, please discuss this with the Liebherr-Werk Bischofshofen GmbH.

The Liebherr wheel loaders





Wheel loader

		L 538 Speeder
Tipping load	kg	9,900
Bucket capacity	m ³	2.6
Operating weight	kg	14,850
Engine output	kW / HP	168/228

04.22

Equipment

 Basic wheel loader	L 538
Tow hitch	●
Automatic engine shutdown (after 5 minutes at idle speed < 1,000 rpm)	+
Automatic central lubrication system Liebherr	+
Electr. equipment for sweeper (socket for sweeper)	+
Electronic tractive force regulation for difficult ground conditions	●
Exhaust tail pipe in stainless steel	+
Travel light (with additional headlights) on front section halogen	+
Travel light (with additional headlights) on front section LED	+
Travel light on front section - halogen	●
Travel light on front section - LED	+
Ride control	+
Fire extinguisher 6 kg	+
Fluff trap for radiator	+
External jump starter equipment	+
Speed limiter 20 km/h	+
Plastic diesel exhaust fluid tank	●
Integrated tyre pressure monitoring system	+
Rear license panel light	+
Combined inching-braking system	●
Mudguard in plastic design	●
Steel fuel tank	+
Fuel pre-filter	●
Fuel pre-filter with pre-heating	+
Large-mesh radiator	+
Cooling water pre-heating 230 V	+
Adjustable plastic mudguard	+
Multi-disc limited slip differentials in both axles	●
Liebherr biodegradable hydraulic oil	+
Reversible fan drive	+
Automatic delayed engine stop (5 min.)	+
Plastic wheel case flare	+
Steel design adjustable wheel case flare	+
SCR technology incl. diesel particle filter	●
Auxiliary heater (Additional heating with engine preheating)	+
Air pre-cleaner TOP AIR	+
Toolbox with toolkit	+
Liebherr weighing system with "Truck Payload Assist" (cannot be certified as a regulated weights and measure device)	+

 Equipment	L 538
1st hydraulic additional function on the front incl. lines	+
1st and 2nd hydraulic additional function on the front incl. lines	+
Working hydraulics lockout	●
Continuous mode, additional function	+
Pressure relief for hydraulic additional function	●
Stroke limit damping	+
Fork carrier and pallet forks	+
High-dump bucket	+
Automatic lift arm position and lowering programmable	●
Lift arms 2,650 mm	●
Lift arms 3,000 mm	+
Hydraulic quick hitch	+
Hydraulic quick hitch LIKUFIX	+
Hydraulic quick change device preparation LIKUFIX	+
Sweeper mode	+
Adjustable tipping speed	●
Tilt cylinder protection	+
Light material bucket	+
Pipe break protection (lift and tilt cylinders)	+
Automatic return high dump bucket	+
Bucket tilt assistant	+
Bucket bearing seal (standard)	●
Bucket return-to-dig (automatic and programmable)	●
Bucket return-to-dig via button	+
Float position	●
Visualisation of the equipment position	●

Equipment



Operator's cab

L 538

2-in-1 steering	+
Adapter plate for additional fastening on the multi-function rail	●
Adaptive working lighting	+
Exterior mirror, electrical adjustable, with heating	+
Exterior mirrors, folding and heated	+
Folding exterior mirror	●
Hinged window (left)	+
Access assistance to facilitate cleaning windscreen	●
Operation with multi-lever control	+
Operating hour meter (mechanic)	+
Electronical theft protection with code	+
Electronical theft protection with key	+
Automatic driver identification	+
Manual driver identification	+
"Comfort" operator's seat with "Comfort integrated" pneumatic suspension Grammer (with seat heating and 3-point belt)	+
"Comfort" operator's seat with "Comfort integrated" pneumatic suspension Grammer (with seat heating and 4-point belt)	+
"Comfort" operator's seat with "Comfort integrated" pneumatic suspension Grammer (with seat heating)	●
"Premium" operator's seat with low frequency suspension - with seat air conditioning, seat heating and head rest - Grammer	+
Particle filter F7	●
Fire extinguisher in cab 2 kg	+
Radio unit installation (preparation)	+
V _{max} speed limit adjustable via button on control unit	●
Speed limit & fixed speed	+
Seat belt warning device (visual) - green warning flashlight on cab	+
Rear window heated electrically	●
Button-operated horn via right button	+
Interior mirror left	●
Joystick steering	+
Joystick steering only	+
Floor mat	●
Clothes hook	●
Air conditioning system	+
Automatic air conditioning system	+
Comfort safety door (open through 180°)	+
Head rest	+
Cool box	+
Steering column height-adjustable	+
Steering column folding	●
LiDAT hardware	●
Liebherr control lever with mini-joystick	+
Liebherr control lever with buttons	●
Multifunctional rail, right	●



Operator's cab

L 538

Emergency steering pump	●
Premiumdisplay (Touchscreen), with height adjustment and tilting function	●
Radio "Comfort" (DAB+ / USB / AUX / BLUETOOTH / handsfree set)	+
Radio "Standard"	+
Preparation for radio installation	+
Amber beacon swiveling LED	+
Headlights activation (on the cab) for reverse travel	+
Soundproof ROPS / FOPS cab	●
Wipe and wash system	●
Windscreen wiper single-sweep function with button	+
Headlights rear, triple design, LED	+
Headlights rear, single design, halogen	+
Headlights rear, single design, LED	+
Headlights rear, double design, halogen	+
Headlights rear, double design, LED	+
Headlights front, double design, halogen	●
Headlights front, double design, LED	+
Headlights activation for reverse travel (on the cab)	+
Sliding window right	●
Slipcover for operator seat	+
Beacon activation in reverse travel	+
Sunblind rear	+
Sunblind front	+
Power socket 12 V	●
USB charging port	+
First aid kit	●
Preparation for protective ventilation device	+
Preparation for dust filtrating device	+
Wide angle mirror	+
Cigarette lighter	●



Safety

L 538

Active personnel detection at the rear	+
Main battery switch (lockable)	+
Roof camera for front area monitoring	+
Standard parking brake	●
Custom paintwork	+
Back-up alarm (acoustical)	+
Reversing alarm LED warning flashlight (visual) (adjustable to 0 - constant - reverse travel)	+
Rear space monitoring with camera	●
Skyview 360°	+

- = Standard
- + = Option
- = not available

Further information can be found in the brochure "Assistance systems for wheel loaders" or you can find here:



Here you can download our wheel loader brochures:



The Liebherr Group

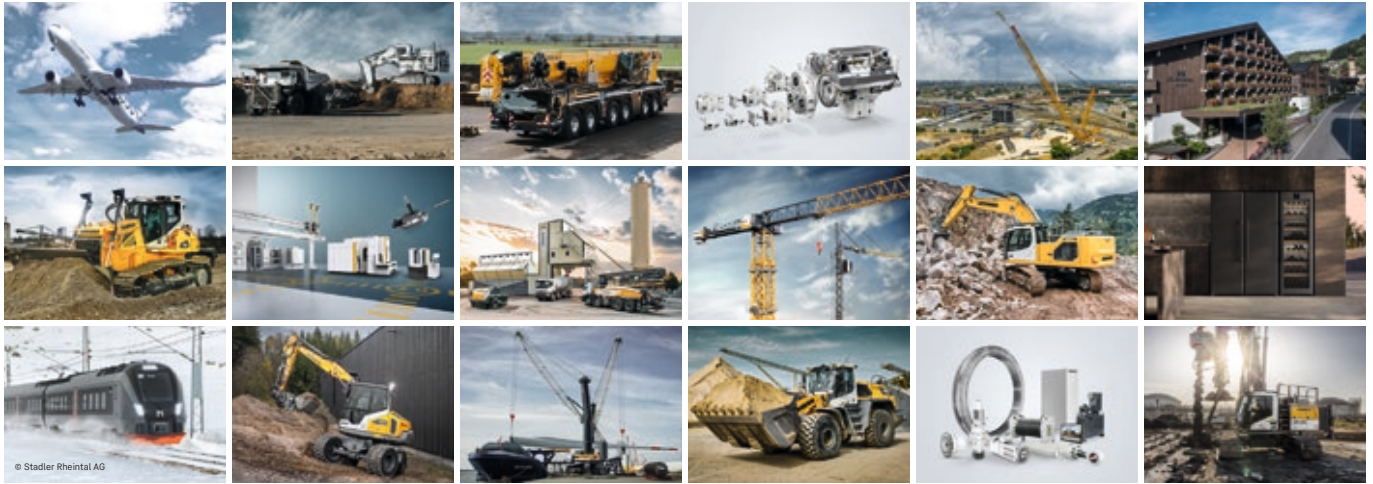

Global and independent: more than 75 years of success

Liebherr was founded in 1949 when, with the development of the world's first mobile tower crane, Hans Liebherr laid the foundations for a family-run company which now has more than 55,000 employees and comprises over 150 companies across every continent. The holding company of the Group is Liebherr-International AG in Bulle, Switzerland, whose shareholders are exclusively members of the Liebherr family.

Technology leadership and pioneering spirit

Liebherr is a pioneer and its forward-looking approach has seen it make important contributions to technology history over a wide variety of industries. Employees throughout the world continue to share the courage of the company founder, sharing a passion to produce innovative products and a determination to provide world-leading equipment and machinery.

Diversified product programme

Liebherr is one of the world's biggest construction machine manufacturers and provides high-quality, user-oriented products and services. Its product range includes the product segments earthmoving, material handling, deep foundation, mining, mobile and crawler cranes, tower cranes, concrete technology, maritime cranes, aerospace and transportation systems, gear technology and automation systems, refrigerators and freezers, components and hotels.

Customised solutions and maximum customer value

Liebherr solutions are characterised by precision, implementation and longevity. The company is committed to technological excellence and to providing customers with solutions that match their needs exactly. For Liebherr, customer focus does not end with delivery of a product but continues through a comprehensive range of back-up and support services.

www.liebherr.com

Liebherr-Werk Bischofshofen GmbH

Liebherr-Werk Bischofshofen GmbH

Postfach 49 · 5500 Bischofshofen, Austria · Phone +43 50809-10

info.lbh@liebherr.com · www.liebherr.com · www.facebook.com/LiebherrConstruction