



User Guide

Quality, Design and Innovation



home.liebherr.com/fridge-manuals









LIEBHERR

Contents

1	Appliance at a glance.....	2
1.1	Scope of delivery.....	2
1.2	Overview of appliances and equipment.....	3
1.3	SmartDevice.....	3
1.4	Appliance range of use.....	3
1.5	Conformity.....	4
1.6	Spare parts.....	4
2	Functionality of the Touch & Swipe display.....	4
2.1	Navigation and symbol explanation.....	4
2.2	Menus.....	4
2.3	Sleep mode.....	5
3	Putting into operation.....	5
3.1	Switching on appliance (first use).....	5
4	Storage.....	6
4.1	Information regarding storage.....	6
4.2	Storage sketches.....	6
5	Saving energy.....	7
6	Controls.....	7
6.1	Control and display elements.....	7
6.1.1	Status display.....	7
6.1.2	Display symbols.....	8
6.1.3	Acoustic signals.....	8
6.2	Appliance functions.....	8
6.2.1	Notes on the appliance functions.....	8
6.2.2	Switching appliance on and off	8
6.2.3	WiFi	9
6.2.4	Temperature	10
6.2.5	Temperature unit	10
6.2.6	SabbathMode	10
6.2.7	HumiditySelect	11
6.2.8	Presentation light	11
6.2.9	Display brightness	11
6.2.10	Door alarm	12
6.2.11	Light alarm	12
6.2.12	Alarm tone	12
6.2.13	Key tone	13
6.2.14	Door lock	13
6.2.15	Display lock	14
6.2.16	Access codes.....	15
6.2.17	Language	18
6.2.18	Device information	18
6.2.19	Software	18
6.2.20	Reminder	19
6.2.21	Demo mode	19
6.2.22	Resetting to factory settings	20
6.3	Message.....	20
6.3.1	Warnings.....	20
6.3.2	Reminders.....	21
7	Features.....	21
7.1	Safety lock.....	21
7.2	Wooden grid.....	22
7.3	Labels.....	23
7.4	Water box*.....	23
8	Maintenance.....	24
8.1	FreshAir activated carbon filter.....	24
8.2	Cleaning the appliance.....	24
9	Customer help.....	25
9.1	Technical specifications.....	25
9.2	Operating noises.....	25
9.3	Technical fault.....	26
9.4	Customer Service.....	27
9.5	Model plate.....	27
10	Shutting down.....	27

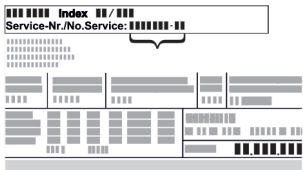
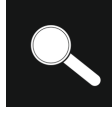
The manufacturer is continually working on the further development of all types and models. Please be aware that

we reserve the right to make changes to the shape, equipment and technology.

Symbol	Explanation
	Read instructions Please read the information in these instructions carefully to understand all of the benefits of your new appliance.
	Additional information on the Internet The digital manual with additional information can be found via the QR code on the front of the manual or by entering the service number at home.liebherr.com/fridge-manuals . The service number can be found on the serial tag:  <i>Fig. Example illustration</i>
	Check appliance Check all parts for transport damage. If you have any complaints, please contact your agent or customer service.
	Differences These instructions apply to a range of models, so differences are possible. Sections that apply to certain models only are marked with an asterisk (*).
	Instructions and results Instructions are marked with a ▶. Results are marked with a ▷.
	Videos Videos about the appliances are available on the YouTube channels of Liebherr-Hausgeräte.

Open source licences:

The appliance contains software components that use open source licences. Information on the open source licences used can be found here: home.liebherr.com/open-source-licences

These operating instructions apply to:

WP.. 52.. / 74..

1 Appliance at a glance

1.1 Scope of delivery

Check all parts for transport damage. Contact your dealer or customer service in the event of complaints. (see 9.4 Customer Service)

Your new appliance comes with the following parts:

- Standalone appliance
- Features (depending on the model)
- Installation materials (depending on the model)
- “Quick Start Guide”
- “Installation Guide”

1.2 Overview of appliances and equipment

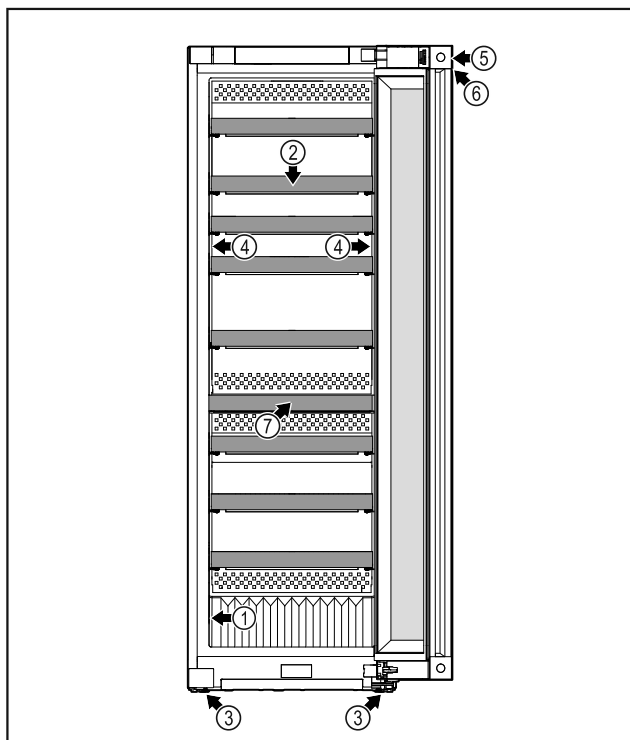

Fig. 1 WP. 5272 / 7472 / 5262 / W5270

- | | |
|-----------------------|--|
| (1) Type plate | (5) Lock |
| (2) Wooden grid shelf | (6) Control elements and temperature display |
| (3) Adjustable foot | (7) Activated charcoal filter |
| (4) Interior lighting | |

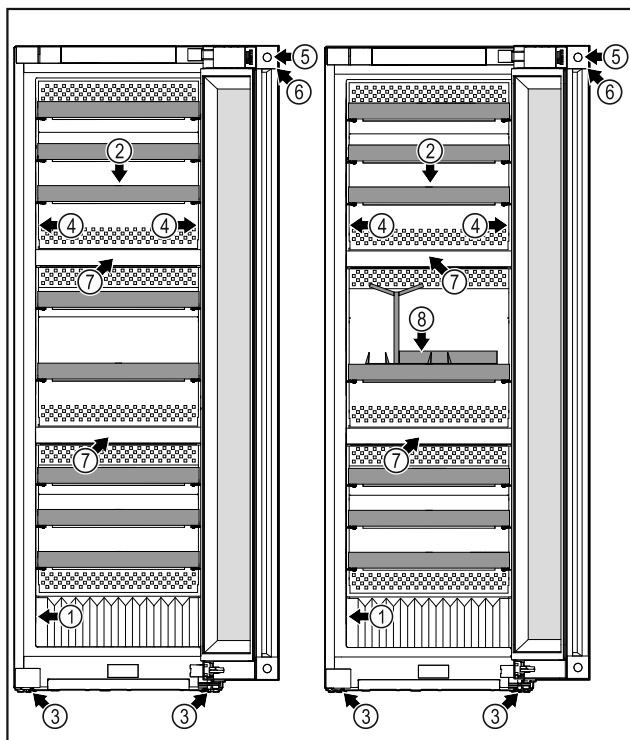

Fig. 2 WP. 5273 / 7473

WP. 5283 / 7483 / Wgb7470

- | | |
|-----------------------|--|
| (1) Type plate | (5) Lock |
| (2) Wooden grid shelf | (6) Control elements and temperature display |
| (3) Adjustable foot | (7) Activated charcoal filter |
| (4) Interior lighting | (8) Sommelier set* |

1.3 SmartDevice

SmartDevice is the networking solution for your wine storage cabinet.

If your appliance SmartDevice-enabled or compatible, you can quickly and easily connect your appliance to your WiFi. With the SmartDevice app, you can operate your appliance from a mobile device. Additional functions and setting options are available in the SmartDevice SmartDevice app.

SmartDevice-enabled appliance: Your appliance is capable of being a SmartDevice. To be able to connect your device to WiFi, you need to download the SmartDevice app.

More information about SmartDevice: smartdevice.liebherr.com

Downloading the SmartDevice app:



After installing and configuring the SmartDevice app, you can connect your appliance to your Wi-Fi (see 6.2.3 Wi-Fi) using the SmartDevice app and the appliance's Wi-Fi function.

Note

The SmartDevice function is not available in the following countries: Russia, Belarus, Kazakhstan.

1.4 Appliance range of use

Intended use

The appliance is only suitable for storing wine in a domestic or domestic-like environment. This includes, for example, using

- in staff kitchens, bed and breakfast establishments,
- by guests in country houses, hotels, motels and other accommodation,
- for catering and similar services in the wholesale trade.

The appliance is not suitable for freezing food;

The appliance is not suitable as a built-in unit.

All other types of use are not permitted.

Foreseeable misuse

The following applications are expressly forbidden:

- Storing and refrigerating medicines, blood plasma, laboratory preparations or similar substances and products based on the Medical Device Directive 2007/47/EC
- Use in outdoor areas with very high humidity
- Use in areas at risk of explosions

Misusing the appliance may lead to damage to the goods stored or they may spoil.

Climate classifications

Depending on the climate classification the appliance is designed to operate in restricted ambient temperatures. The climate classification applying to your appliance is printed on the rating plate.

Note

- Keep to the specified ambient temperatures in order to guarantee that the appliance works properly.

Functionality of the Touch & Swipe display

Climate classification	for ambient temperatures of
SN	10 °C to 32 °C
N	16 °C to 32 °C
ST	16 °C to 38 °C
T	16 °C to 43 °C
SN-ST	10 °C to 38 °C
SN-T	10 °C to 43 °C

1.5 Conformity

The refrigerant circuit has been tested for leaks. The appliance complies with the applicable safety regulations and with the corresponding directives.

For the EU market:	The appliance complies with directive 2014/53/EU.
For the GB market:	The appliance complies with Radio Equipment Regulations 2017 SI 2017 No. 1206.

The full text of the EU Declaration of Conformity is available on the following website: www.Liebherr.com

1.6 Spare parts



The spare parts availability for functional parts and stockable parts of the equipment is 15 years.





2 Functionality of the Touch & Swipe display

You operate your appliance using the Touch & Swipe display. You select appliance functions in the Touch & Swipe display (hereafter referred to as display) by tapping them. If you do not perform any action on the display for 10 seconds, the display either jumps back to the higher-level menu or directly to the status display.

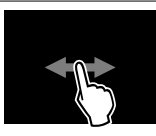
2.1 Navigation and symbol explanation

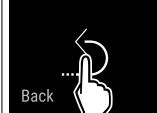
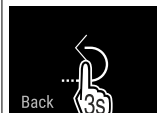
In the illustrations, different symbols are used to navigate the display. The following table describes these symbols.

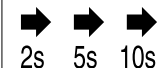
Symbol	Description
	Briefly touch the display: Activates/deactivates function. Confirms selection. Opens submenu.
	Touch the display for a specified time (e.g. 3 seconds): Activates/deactivates function or value.
	Swipe left or right: Navigate in the menu.

Symbol	Description
	Briefly touch the Back symbol: Jumps back one menu level.
	Press and hold the Back symbol for 3 seconds: Jumps back to the status display.
	Briefly touch the Back symbol at the top left: Jumps back one menu level.
	Arrow with clock: It takes more than 10 seconds for the following message to appear in the display.
	Arrow with a time indication: It takes the specified amount of time until the following message appears in the display.
	“Open Settings menu” symbol: Navigates to the Settings menu and opens the settings menu. If necessary: Navigate to the desired function in the Settings menu. (see 2.2.1 Opening the Settings menu)
	“Open Advanced menu” symbol: Navigates to the Advanced menu and opens the advanced menu. If necessary: Navigate to the desired function in the Advanced menu. (see 2.2.2 Opening the expanded menu)
No action for 10 seconds	If you do not perform any action on the display for 10 seconds, the display either jumps back to the higher-level menu or directly to the status display.
Open door and close it again.	If you open the door and immediately close it again, the display jumps directly back to the status display.

Note: Illustrations of the display are shown in the English version.

2.2 Menus

The appliance functions are distributed over various menus:

Menu	Description
Main menu	When you switch the appliance on, you are automatically in the main menu. From here you can navigate to the most important appliance functions, to the Settings menu and to the Advanced menu.

3 Putting into operation

3.1 Switching on appliance (first use)

Ensure that the following requirements are met:

- Appliance is installed and connected.
- All adhesive strips, adhesive and protective films and transport locks are removed from inside and outside the appliance.

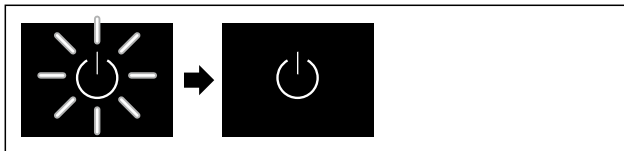

Fig. 5 Example illustration

- ▶ The standby symbol is flashing: Wait until the start process is complete.
- ▶ The display shows the standby symbol.

If the appliance is delivered with factory settings, the screen language must first be set during commissioning.

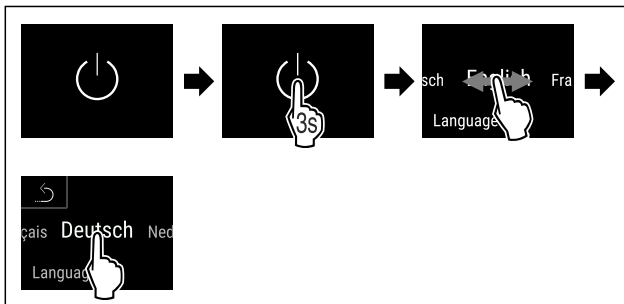

Fig. 6

- ▶ Carry out action steps according to the illustration.
- ▶ Language is set.

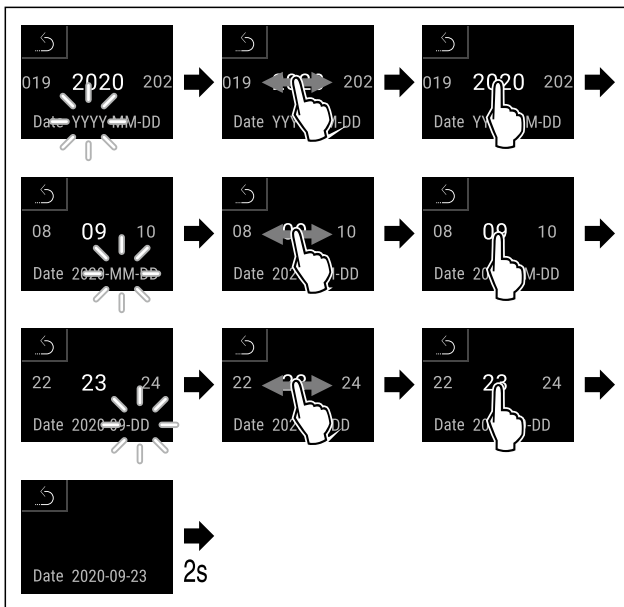

Fig. 7

- ▶ Carry out action steps according to the illustration.
- ▶ Date is set.

Menu	Description
 Settings menu	The Settings menu contains additional appliance functions for setting up your appliance.
 Advanced menu	The advanced menu contains special appliance functions for setting up your appliance. Access to the Advanced menu is protected by the numerical code 151 .

2.2.1 Opening the Settings menu

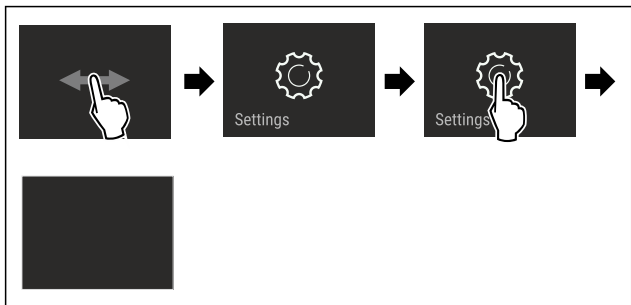

Fig. 3 Example illustration

- ▶ Carry out action steps according to the illustration.
- ▶ Settings menu is open.
- ▶ If necessary: Navigate to the desired function.

2.2.2 Opening the expanded menu

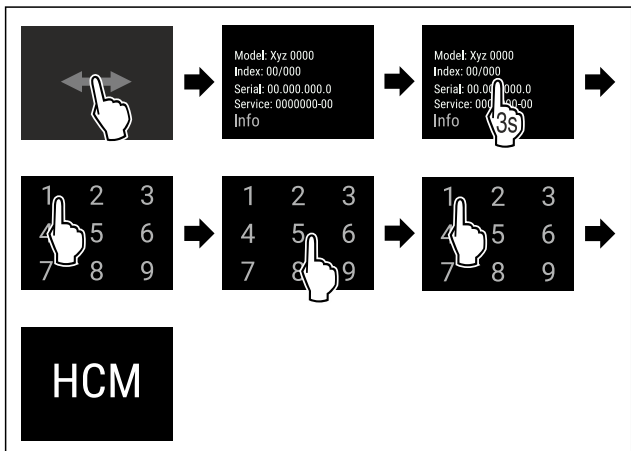

Fig. 4 Access with numerical code **151**

- ▶ Carry out action steps according to the illustration.
- ▶ The expanded menu is open.
- ▶ If necessary: Navigate to the desired function.

2.3 Sleep mode

If you do not touch the display for 1 minute, the display switches to sleep mode. In sleep mode, the display brightness is dimmed.

2.3.1 Ending sleep mode

- ▶ Touch the display briefly with your finger.
- ▶ Sleep mode is ended.

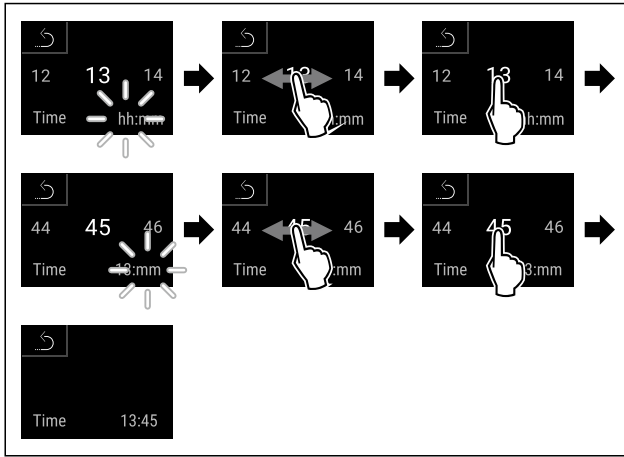

Fig. 8

- ▶ Carry out action steps according to the illustration.
- ▶ Time is set.

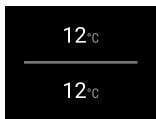

Fig. 11 Status display

- ▶ The appliance is ready for operation once the temperature appears in the display.
- ▶ The temperature display flashes until the set temperature is reached.

4 Storage

4.1 Information regarding storage



WARNING

Fire hazard from electrical appliances!
If you use electrical appliances in the food area of your appliance, they can cause a fire.

- ▶ Do not use electrical appliances in the food area of the appliance unless recommended by the manufacturer.

Note

The energy consumption increases and the cooling power goes down if ventilation is not sufficient.

- ▶ Always keep air slots clear.

Observe the following specifications for storage:

- Keep liquids in closed containers.
- Position storage shelves according to the height required.
- Observe maximum load weight. (see 9.1 Technical specifications)

4.2 Storage sketches

4.2.1 WP.. 5262

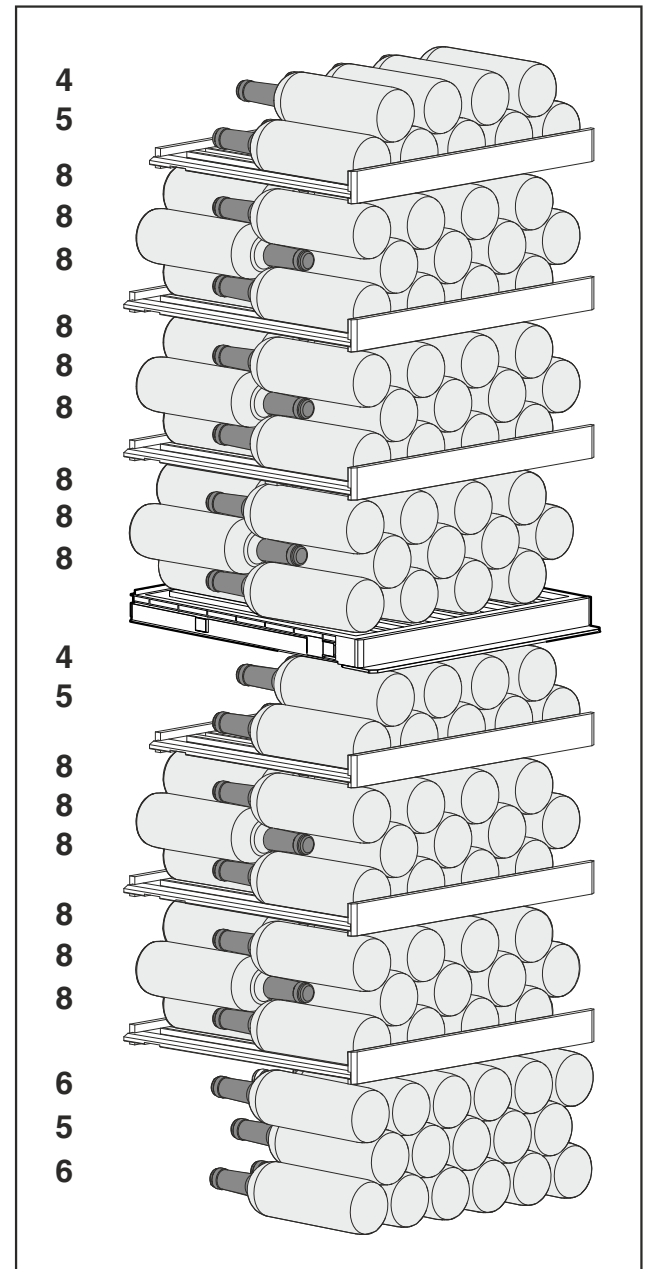

Fig. 12 Total of 155 bottles (for 0.75 l Bordeaux bottles)

4.2.2 WP.. 7473

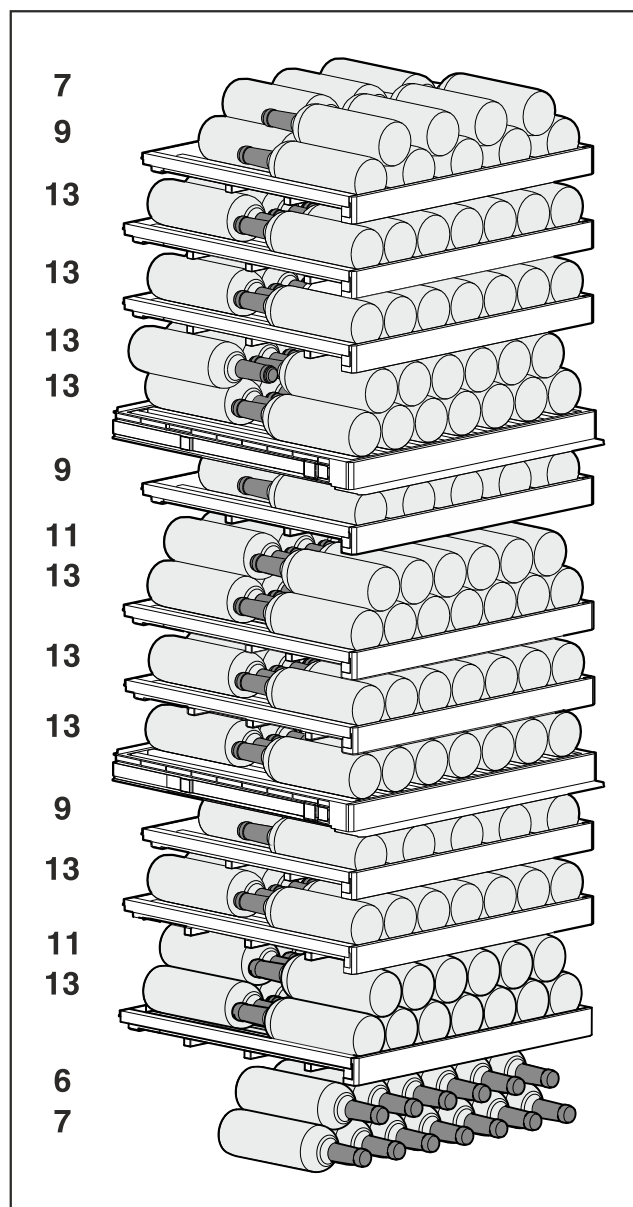

Fig. 13 Total of 182 bottles (for 0.75 l Bordeaux bottles)

5 Saving energy

- Pay attention to good ventilation. Do not cover ventilation holes or grids.
- Always keep the fan air slits clear.
- Do not place the appliance in direct sunlight or near radiators or similar sources of heat.
- If the appliance is placed directly next to an oven, the energy consumption may increase slightly. This is dependent on the service life and usage intensity of the oven.
- Energy consumption depends on the installation conditions, e.g. the ambient temperature (see 1.4 Appliance range of use) . A warmer ambient temperature can increase the energy consumption.
- Open the appliance for as short a time as possible.
- The lower the temperature is set the higher the energy consumption.

6 Controls

6.1 Control and display elements

The display provides a quick overview of the current appliance status, the temperature setting, the status of functions and settings as well as alarm and error messages.

Operation takes place directly on the Touch & Swipe display by swiping and touching.

Functions can be activated or deactivated and setting values can be changed.

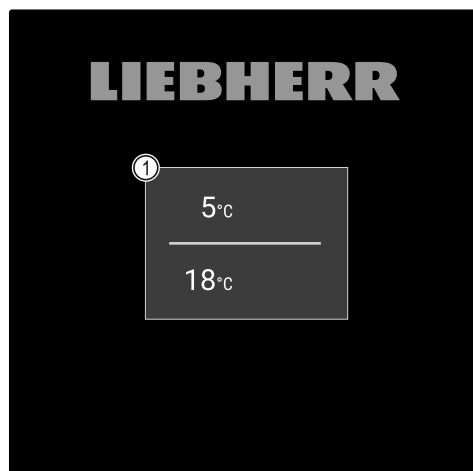

Fig. 14 Touch & Swipe display*

(1) Status display

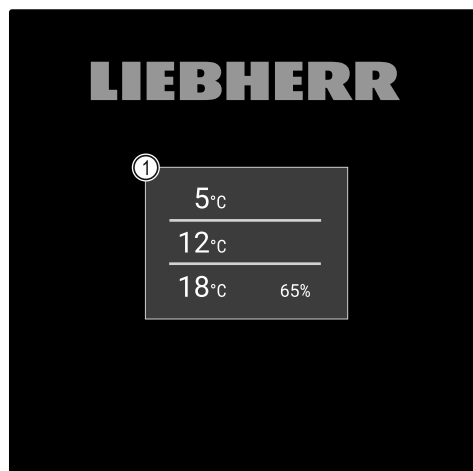

Fig. 15 Touch & Swipe display*

(1) Status display

6.1.1 Status display

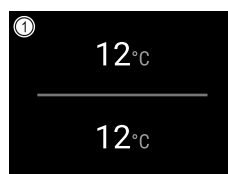

Fig. 16 Status display*

(1) Temperature













The status display is the output display.

Navigation to the functions takes place from the status display.

Controls

6.1.2 Display symbols

Display symbols provide information about the status of the appliance.

Symbol	Appliance status
	Standby symbol Appliance is switched off.
	Standby symbol (flashing) Appliance is starting up.
	Temperature (flashing) Target temperature not yet reached. Appliance cooling to temperature set.
	Status display (white frame) Appliance is locked.
	D in the display The appliance is in demo mode.
	Data memory full (yellow) The data memory (999 hours) is full. The oldest data will be overwritten from now on.
	Memory full alarm (yellow) The alarm memory is full. Delete individual alarms or the entire memory.
	Manual door opening (yellow) The locked door was opened manually.
	Error symbol (red) Appliance is in error state.
	Background (blue) Active setting or active function
	Bar (increasing) Press for 3 seconds to activate the setting.
	Bar (decreasing) Press for 3 seconds to deactivate the setting.

Symbols on the status display

6.1.3 Acoustic signals

A signal sounds in the following cases:

- If a function or a value is confirmed.
- If a function or a value can either not be activated or not deactivated.
- As soon as an error occurs.
- If there is an alarm message.

The alarms can be switched on and off in the customer menu.

6.2 Appliance functions

6.2.1 Notes on the appliance functions

The appliance functions are set at the factory so that your appliance is fully functional.

Before you alter, activate or deactivate the device functions, make sure that the following requirements are met:

- You have read and understood the descriptions of how the display works. (see 2 Functionality of the Touch & Swipe display)
- You have familiarised yourself with the operating and display elements of your appliance. (see 6.1 Control and display elements)



6.2.2 Switching appliance on and off

This function makes it possible to switch the entire appliance on and off.

Switching on appliance

If demo mode is not activated:

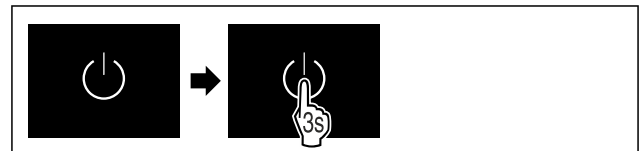

Fig. 17

- ▶ Carry out action steps according to the illustration.

If demo mode is activated:

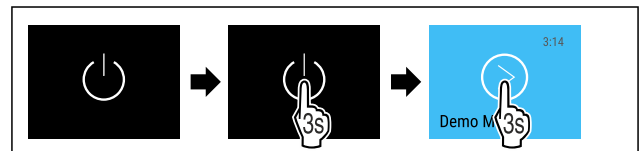

Fig. 18

- ▶ Carry out action steps according to the illustration.

Note

Deactivate demo mode before the countdown has finished.

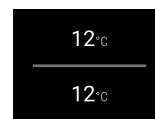

Fig. 21 Status display

- ▶ The temperature appears in the display.

Switching off appliance



Fig. 22

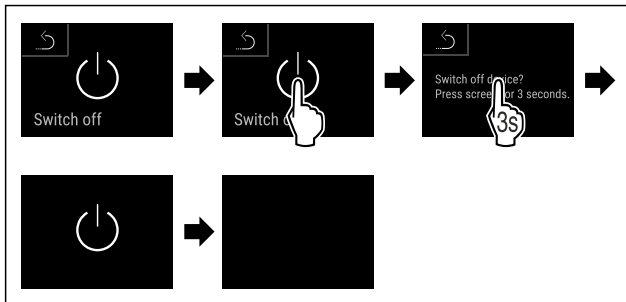

Fig. 23

- ▶ Carry out action steps according to the illustration.
- ▶ Standby symbol is shown in the display.
- ▶ The display switches off automatically after around 10 minutes.

6.2.3 WiFi



Use this function to connect your appliance to WiFi. You can then operate it via the SmartDevice app on a mobile device. You can also use this function to disconnect or reset the WiFi connection.

More information on the SmartDevice: (see 1.3 SmartDevice)

Note

The SmartDevice function is not available in the following countries: Russia, Belarus, Kazakhstan.

Establishing the WiFi connection for the first time

Make sure that the following requirements are fulfilled:

- You have installed the SmartDevice app (see apps.home.liebherr.com).
- Registration in the SmartDevice app is completed.



Fig. 24

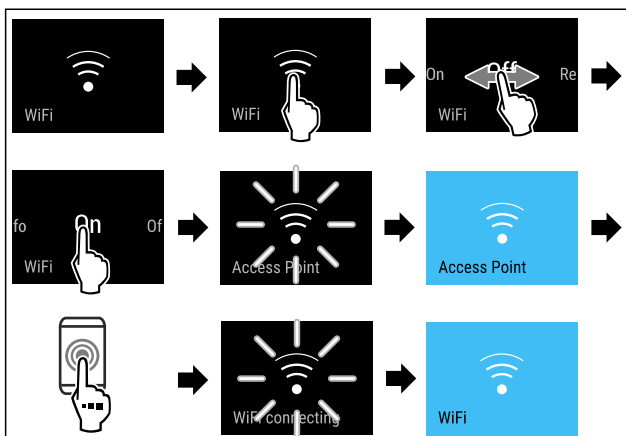

Fig. 25

- ▶ Carry out action steps according to the illustration.
- ▶ Connection is established.

Disconnecting from the WiFi



Fig. 26

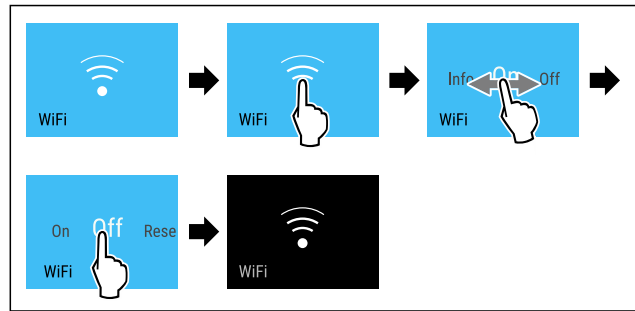

Fig. 27

- ▶ Carry out action steps according to the illustration.
- ▶ There is no connection.

Resetting the WiFi connection



Fig. 28

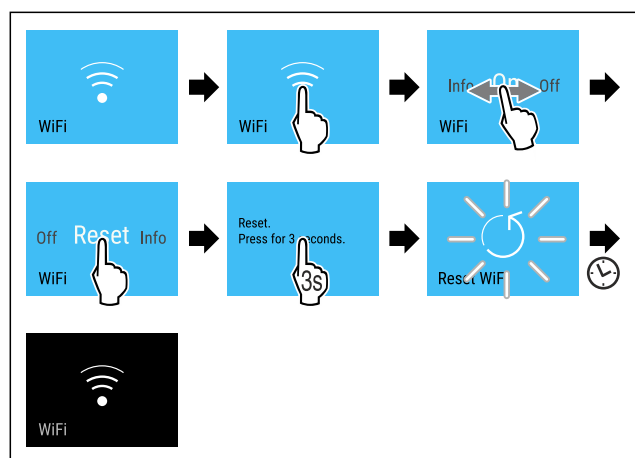

Fig. 29

- ▶ Carry out action steps according to the illustration.
- ▶ WiFi connection and other WiFi settings are reset to factory settings.

Showing information about the WiFi connection



Fig. 30

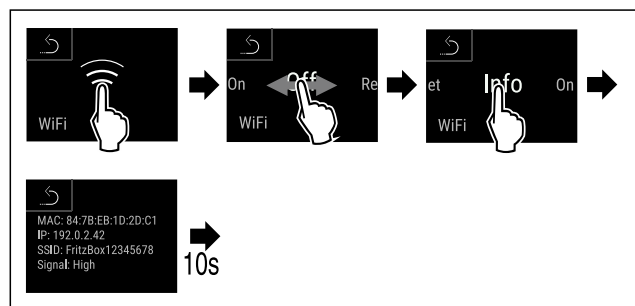

Fig. 31

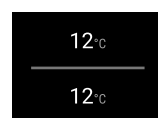

Fig. 32 Status display

- ▶ Carry out action steps according to the illustration.

Controls



6.2.4 Temperature

The temperature depends on the following factors:

- How often the door is opened
- How long the door is open for
- The room temperature of the installation site
- The type, temperature and amount of refrigerated food

Note

The temperature may differ from the temperature displayed in some areas of the interior.

At the correct temperature, cooled produce will keep for longer. This avoids disposing of food unnecessarily.

Setting temperature

The following steps describe how to increase the temperature, e.g. from 5 °C to 10 °C.

- ▶ Tap the temperature of the desired zone.

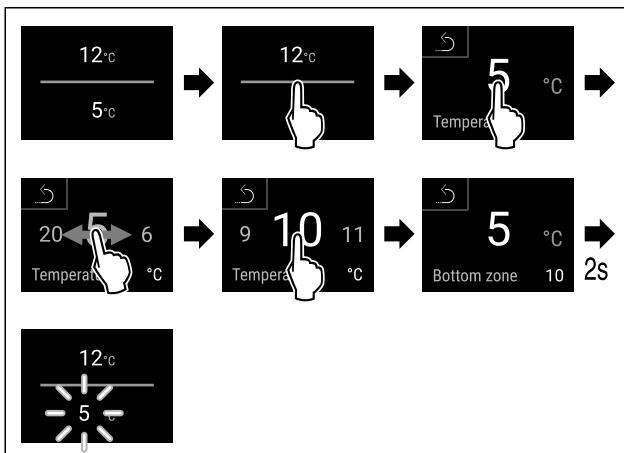

Fig. 33 *

- ▶ Carry out action steps according to the illustration.
- ▶ Temperature is set.



6.2.5 Temperature unit

Use this function to set the temperature unit. You can set degrees Celsius or degrees Fahrenheit as the temperature unit.

Setting the temperature unit

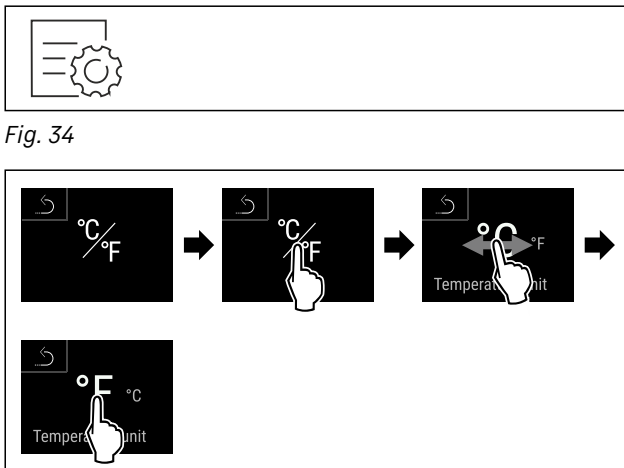

Fig. 36 Example illustration: Switch from degrees Celsius to degrees Fahrenheit.

- ▶ Carry out action steps according to the illustration.

- ▶ The temperature unit is set.



6.2.6 SabbathMode

You can use this function to activate or deactivate SabbathMode. If you activate this function, some electronic functions are switched off. As a result, your device meets the religious requirements for Jewish holidays such as Sabbath and complies with STAR-K Kosher certification.

Device status when SabbathMode is active
The status display shows SabbathMode permanently.
All functions on the display are locked except for the Deactivate SabbathMode function .
Active functions remain active.
The display remains bright when you close the door.
The interior lighting is deactivated.
Reminders are not implemented. The set time interval stops.
Reminders and warnings are not displayed.
There is no door alarm.
There is no temperature alarm.
After a power failure, the appliance returns to SabbathMode.

Device status

Note

This appliance has certification from the "Institute for Science and Halacha". (www.machonhalacha.co.il)

You can find a list of STAR-K-certified appliances at www.star-k.org/appliances.

Activating SabbathMode



Fig. 37



Fig. 38

- ▶ Carry out action steps according to the illustration.
- ▶ SabbathMode is activated.
- ▶ The status display shows SabbathMode permanently.

Deactivating SabbathMode

The SabbathMode is automatically deactivated after 80 hours. However, you can also deactivate SabbathMode manually at any time:

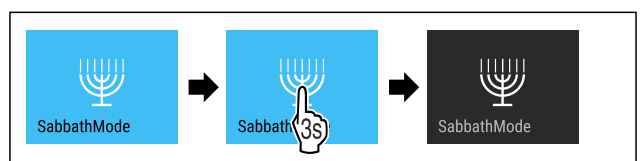
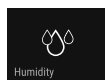

Fig. 39

- ▶ Carry out action steps according to the illustration.
- ▶ SabbathMode is deactivated.

▷ Door is locked automatically.

6.2.7 HumiditySelect



Use this function to set the humidity inside your appliance. Setting the humidity correctly will have a positive effect on the structure of the corks during long-term storage and prevent them from drying out.

Note

The frequency and duration for which the door is open influence the humidity in the appliance.

You can choose between two humidity settings:

HumiditySelect function	Temperature setting on the appliance	Application/energy consumption
Standard (preset)	10-12 °C	average humidity in the environment between 50-80% low energy consumption of the appliance
High	10-12 °C	average humidity in the environment < 50% energy consumption of the appliance increases

Increasing the humidity in the appliance

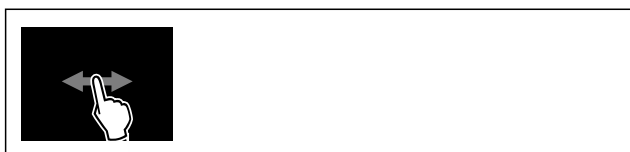

Fig. 40

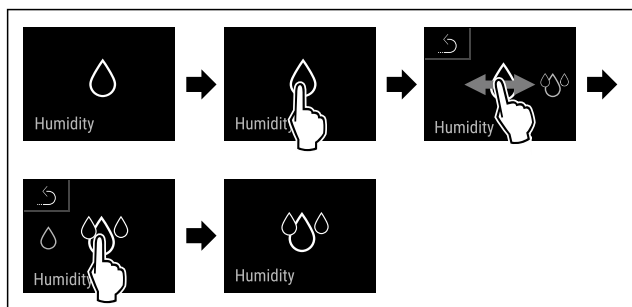

Fig. 41

- ▶ Carry out action steps according to the illustration.
- ▷ Humidity in the appliance increases.

Setting the humidity in the appliance to standard



Fig. 42

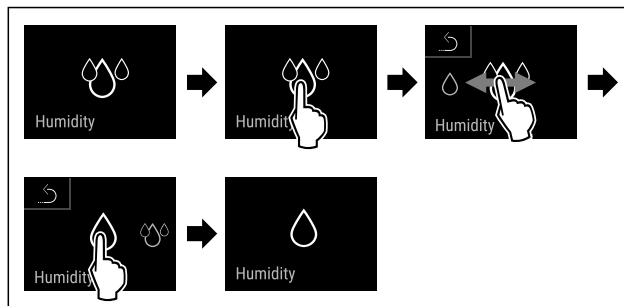

Fig. 43

- ▶ Carry out action steps according to the illustration.
- ▷ Humidity in the appliance decreases.

6.2.8 Presentation light



Use this function to set the interior lighting.

The following brightness levels can be set:

- Off
- 20%
- 40%
- 60%
- 80%
- 100% (default)

Setting the lighting

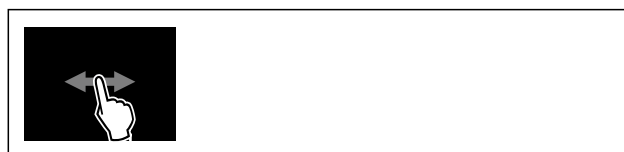

Fig. 44

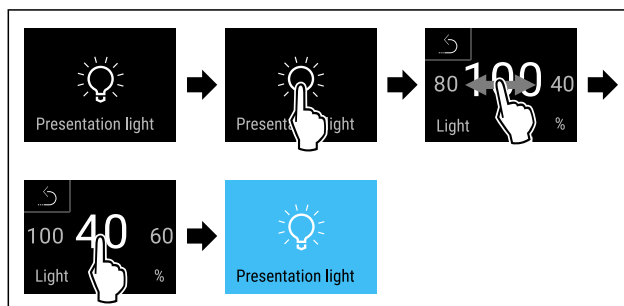

Fig. 45 Example illustration: Switch from 100% to 40%

- ▶ Carry out action steps according to the illustration.
- ▷ The brightness is set.

6.2.9 Display brightness



Use this function to set the display brightness in stages.

You can select the following brightness levels:

- 20 %
- 40 %
- 60 %
- 80 %
- 100 % (pre-setting)

Controls

Setting the brightness



Fig. 46

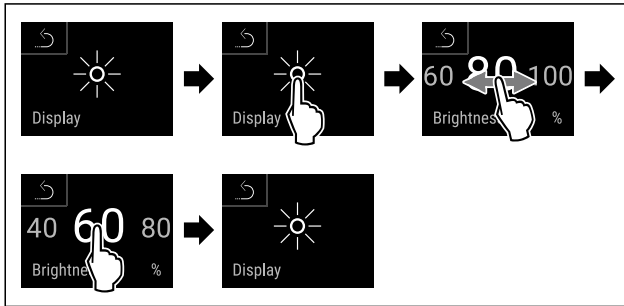

Fig. 47 Example illustration: Switch from 80 % to 60 %.

- ▶ Carry out action steps according to the illustration.
- ▷ The brightness is set.



6.2.10 Door alarm

Use this function to activate or deactivate the door alarm. The door alarm sounds if the door is open for too long. The door alarm is activated on delivery. You can set how long the door may be open before the door alarm sounds.

The following values can be set:

- 1 minute
- 2 minutes
- 3 minutes
- Off

Setting the door alarm



Fig. 48

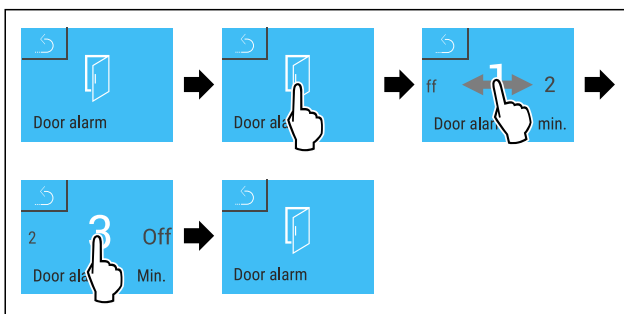

Fig. 49 Example illustration: Change door alarm from 1 minute to 3 minutes.

- ▶ Carry out action steps according to the illustration.
- ▷ The door alarm is set.

Deactivating the door alarm



Fig. 51

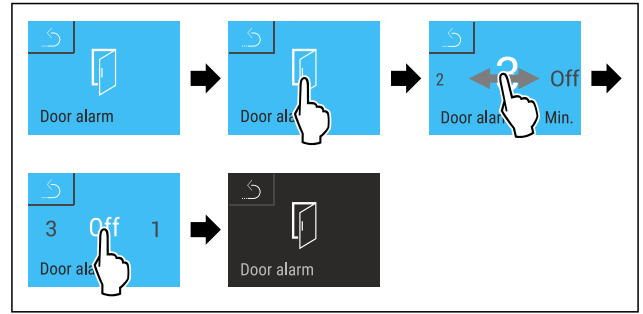

Fig. 52

- ▶ Carry out action steps according to the illustration.
- ▷ The door alarm is deactivated.



6.2.11 Light alarm

This setting allows the visual alarm messages in the display to also be emphasised by flashing appliance lighting.

Activating light alarm



Fig. 53

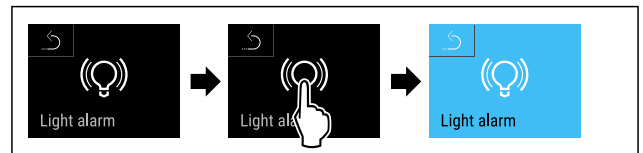

Fig. 54

- ▶ Carry out action steps according to the illustration.
- ▷ The light alarm is activated.

Deactivating light alarm



Fig. 55

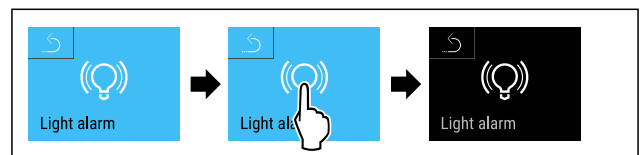

Fig. 56

- ▶ Carry out action steps according to the illustration.
- ▷ The light alarm is deactivated.



6.2.12 Alarm tone

This function enables all alarm sounds, such as door alarms, to be switched on and off.

Activating the alarm tone

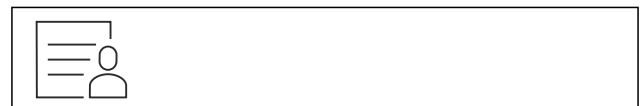

Fig. 57

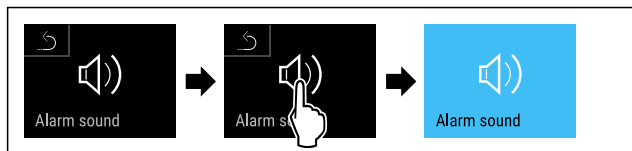

Fig. 58

- ▶ Carry out action steps according to the illustration.
- ▷ The alarm tone is activated.

Deactivating the alarm tone



Fig. 59

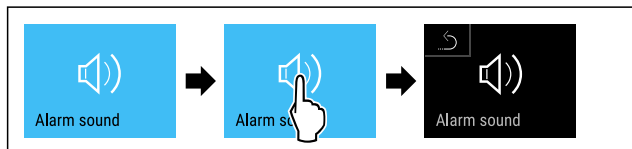

Fig. 60

- ▶ Carry out action steps according to the illustration.
- ▷ The alarm tone is deactivated.

6.2.13 Key tone



This function makes it possible to switch all button sounds, confirmation sounds, and the startup sound on and off.

Activating the key tone



Fig. 61

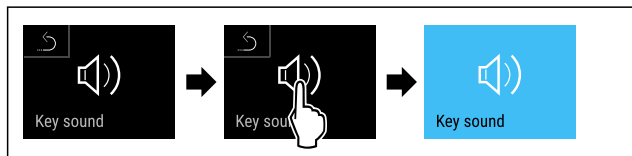

Fig. 62

- ▶ Carry out action steps according to the illustration.
- ▷ The key tone is activated.

Deactivating the key tone

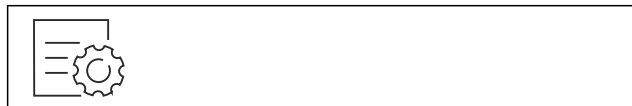

Fig. 63

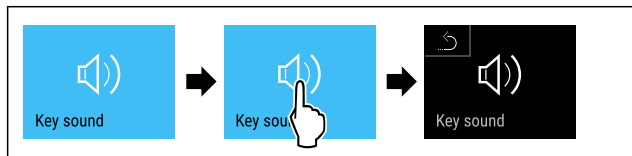

Fig. 64

- ▶ Carry out action steps according to the illustration.
- ▷ The key tone is deactivated.

6.2.14 Door lock



The appliance is fitted with an electronic door lock. **When using the first time, the door is unlocked** and you can open it.

This function means the appliance can be secured against the unwanted removal of items.

You have the following setting options for this:

- Lock door using door code.
- Unlock door using door code.
- Activate automatic locking.
- Deactivate automatic locking.
- Set time delay for automatic locking.
- Change the door code. (see 6.2.16 Access codes)
- Reset the door code. (see 6.2.16 Access codes)
- Pair remote control.

Locking door using door code

Note

- ▶ In the following example, the factory-set PIN code: **1 1 1 1** is used.

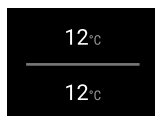

Fig. 65 Status display

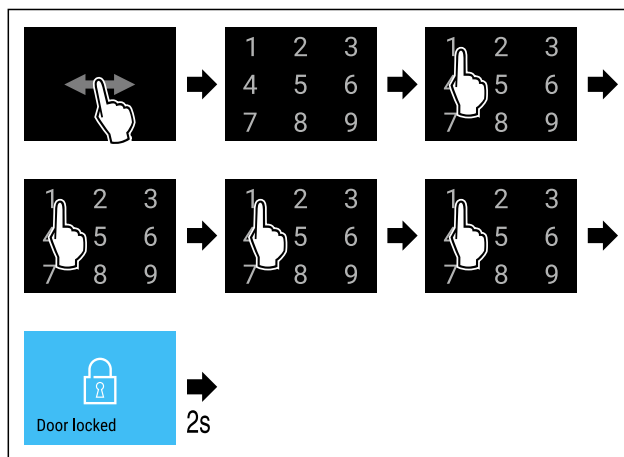

Fig. 66 Locking door using door code 1 1 1 1.

- ▶ Carry out action steps according to the illustration.

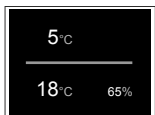

Fig. 67 Status display with white border

- ▷ The door is locked.

Unlocking door using door code

Note

- ▶ In the following example, the factory-set PIN code: **1 1 1 1** is used.

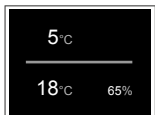

Fig. 68 Status display with white border

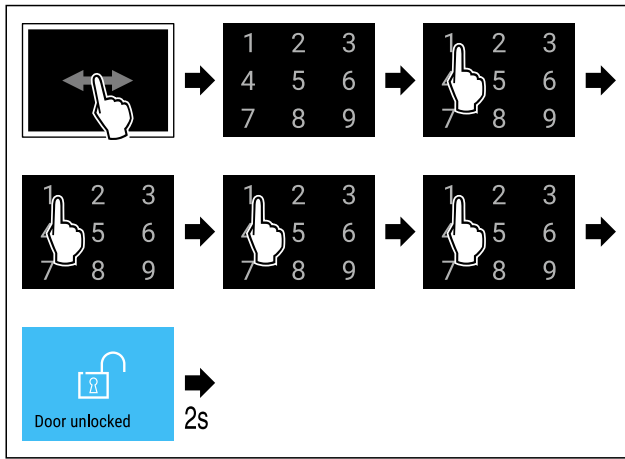

Fig. 69 Unlock the door with door code 1 1 1 1.

- ▶ Carry out action steps according to the illustration.

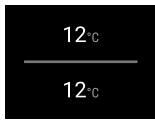

Fig. 70 Status display

- ▶ The door is unlocked.

Activating automatic locking



Fig. 71

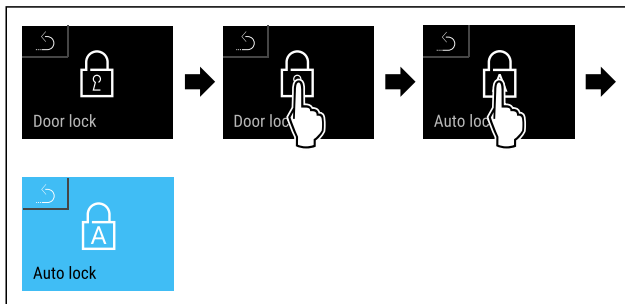

Fig. 72

- ▶ Carry out action steps according to the illustration.
- ▶ Automatic locking is activated.
- ▶ The time delay (see Setting time delay for automatic locking) can now be set.

Note

You can continue to lock and unlock the door using the remote control or by entering the door code.

Deactivating automatic locking

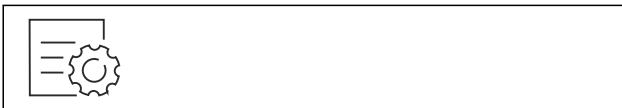

Fig. 73

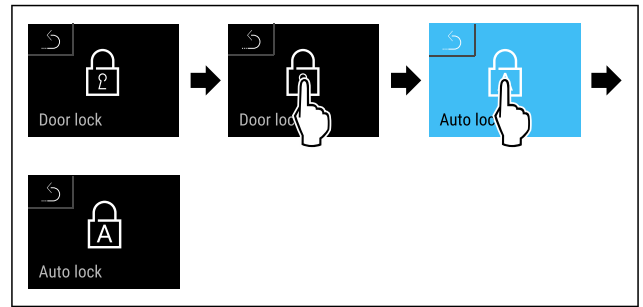

Fig. 74

- ▶ Carry out action steps according to the illustration.
- ▶ Automatic locking is deactivated.

Setting time delay for automatic locking

This function sets the time delay of the automatic door lock after a door is opened.

Make sure that the following requirements are fulfilled:

- ❑ The automatic door locking (see Activating automatic locking) is activated.



Fig. 75

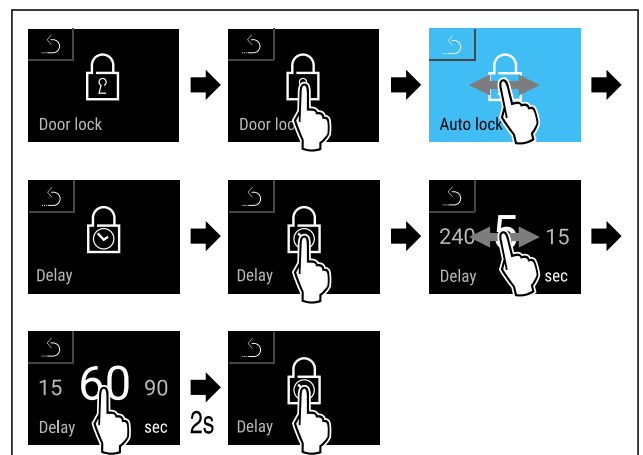

Fig. 76 The following values can be set: 5, 15, 60, 90, 120, 180 and 240 seconds

- ▶ Carry out action steps according to the illustration.
- ▶ Time delay is set.

Changing door code

(see 6.2.16 Access codes)

Resetting door code

(see 6.2.16 Access codes)

Pairing remote control

6.2.15 Display lock

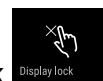

This setting avoids accidental operation of the appliance.

Application:

- Prevent settings and functions being changed unintentionally.
- Prevent appliance being switched off unintentionally.
- Prevent temperature being set unintentionally.

Note

The door lock can be opened and locked at any time with the PIN code (see 6.2.16 Access codes), even when the display lock is activated.

Activating the display lock

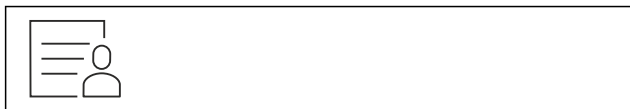

Fig. 77

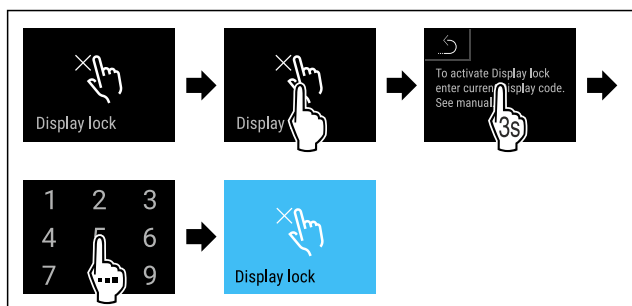

Fig. 78

- ▶ Carry out action steps according to the illustration.
- ▶ The display lock is activated.
- ▶ The status display appears.

Unlocking the display lock for a short time

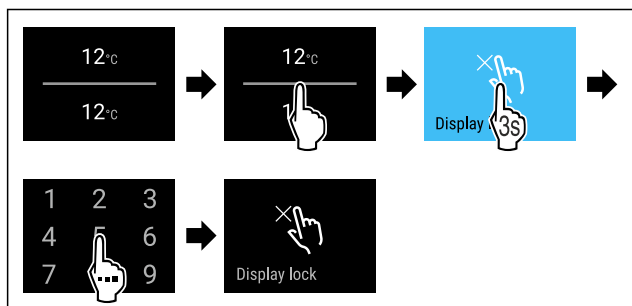

Fig. 79 *

- ▶ Carry out action steps according to the illustration.
- ▶ The display lock is deactivated.
- ▶ The status display appears.

Deactivating the display lock

- ▶ Carry out action steps (see Unlocking the display lock for a short time).

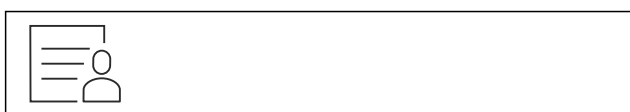

Fig. 80

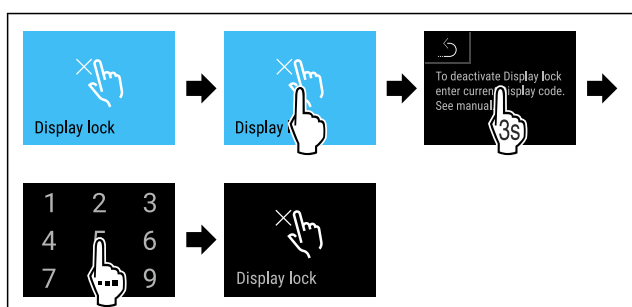

Fig. 81

- ▶ Carry out action steps according to the illustration.
- ▶ The display lock is deactivated.
- ▶ The status display appears.

6.2.16 Access codes

Access codes are required for some functions. You can only use the following functions after entering the appropriate access code:

- Door lock
- Settings menu
- SmartLock
- Display lock



Door code

This function allows the door lock code to be changed or reset.

Changing the door code

The door code can be changed in three steps:

- Enter old door code.
- Enter new door code.
- Confirm new door code.

Note

In the following example, you change the factory-set door code **1 1 1 1** to the new door code **2 3 4 5**.



Fig. 82

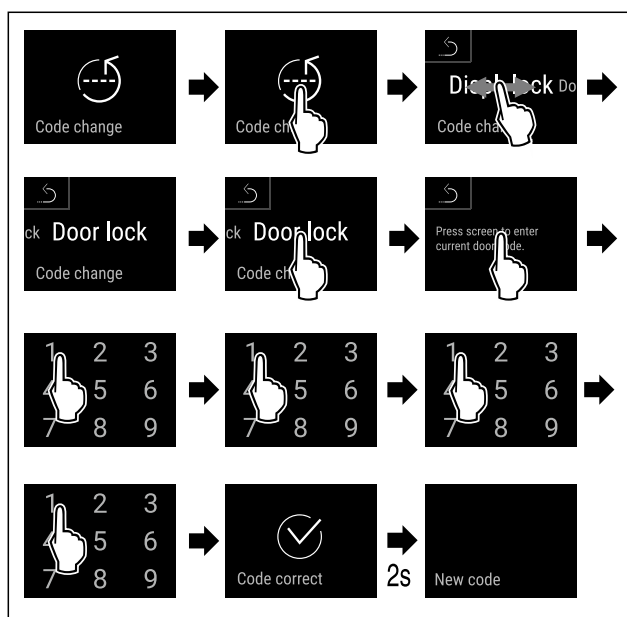

Fig. 83

- ▶ Carry out action steps according to the illustration.
- ▶ Entering the old door code is successful.

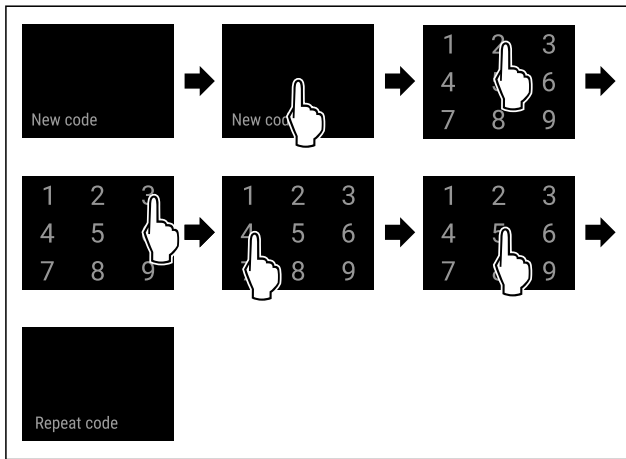

Fig. 84

- ▶ Carry out action steps according to the illustration.
- ▶ The new door code has been successfully entered.

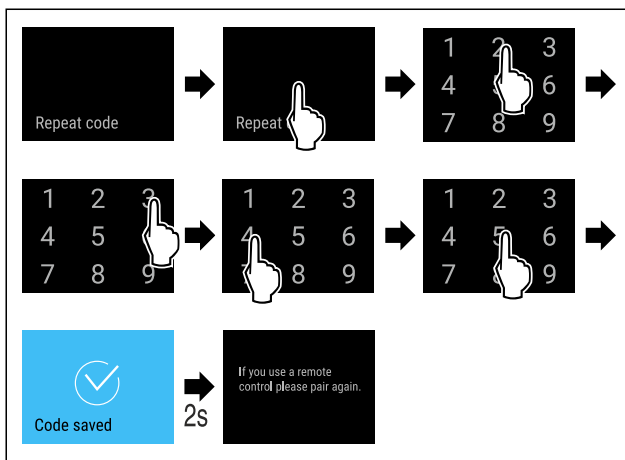

Fig. 85

- ▶ Carry out action steps according to the illustration.
- ▶ Confirmation of the new door code is successful.
- ▶ The door code has been changed.
- ▶ Re-pair the remote.

Resetting the door code

If you no longer know the door code, you can reset it.

- ▶ Reset appliance to factory settings. (see 6.2.22 Resetting to factory settings)
- ▶ The appliance has been reset to its original settings.
- ▶ The factory-set door code is: **1 1 1 1**

Access code for the settings menu



This function allows the access code for the settings menu to be changed or reset.

Changing the access code for the settings menu

The access code can be changed in three steps:

- Enter old access code.
- Enter new access code.
- Confirm new access code.

Note

In the following example, you change the factory-set access code **1 1 1 1** to the new access code **2 3 4 5**.

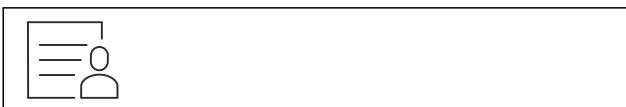

Fig. 86

Access protection for the settings menu must be active.

- ▶ Swipe left or right until corresponding function is displayed.

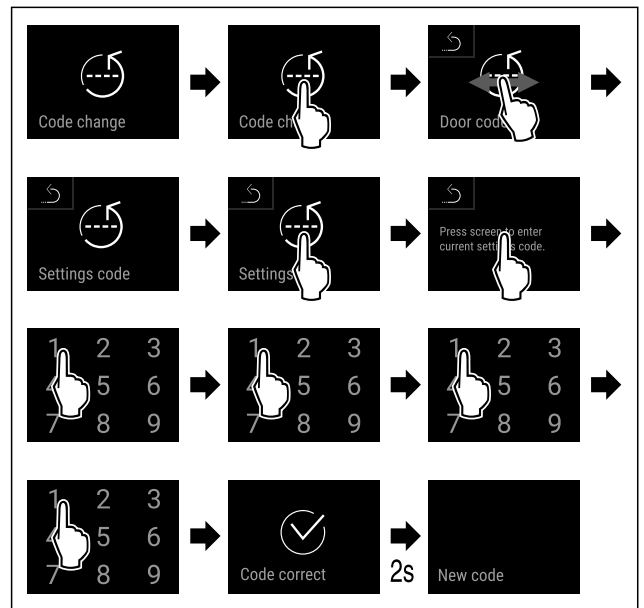

Fig. 87

- ▶ Carry out action steps according to the illustration.
- ▶ Entering the old access code is successful.

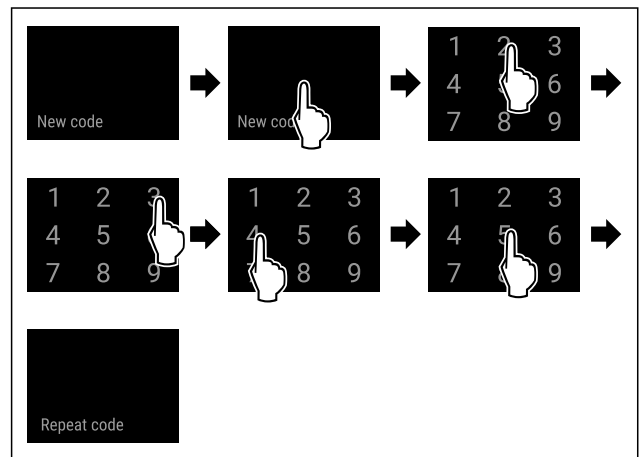

Fig. 88

- ▶ Carry out action steps according to the illustration.
- ▶ The new access code has been successfully entered.

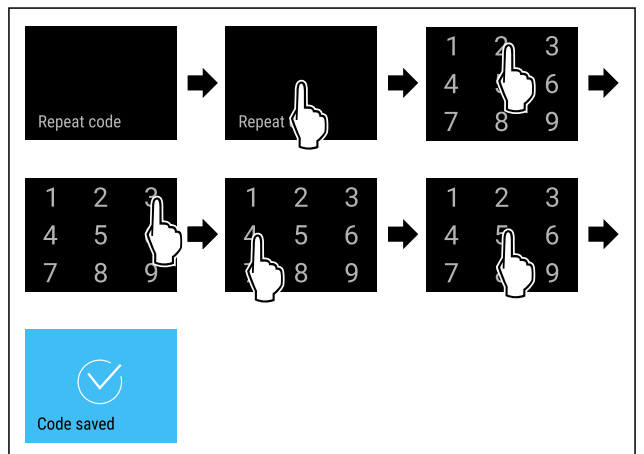

Fig. 89

- ▶ Carry out action steps according to the illustration.
- ▶ Confirmation of the new access code is successful.

- ▶ The access code for the settings menu has been changed.

Resetting the access code for the settings menu

If you no longer know the access code for the settings menu, you can reset it.

- ▶ Reset appliance to factory settings (see 6.2.22 Resetting to factory settings).
- ▶ The appliance has been reset to its original settings.
- ▶ The factory-set access code is: **1 1 1 1**



SmartLock code

This function allows the SmartLock code to be changed or reset.

Changing SmartLock code

The SmartLock-Code can be changed in three steps:

- Enter old SmartLock code.
- Enter new SmartLock code.
- Confirm new SmartLock code.

Note

In the following example, you change the factory-set SmartLock code **1 1 1 1** to the new SmartLock code **2 3 4 5**.

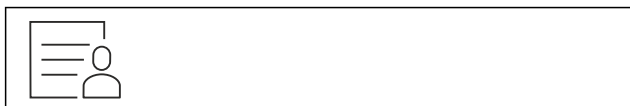

Fig. 90

SmartLock must be active.

- ▶ Swipe left or right until corresponding function is displayed.

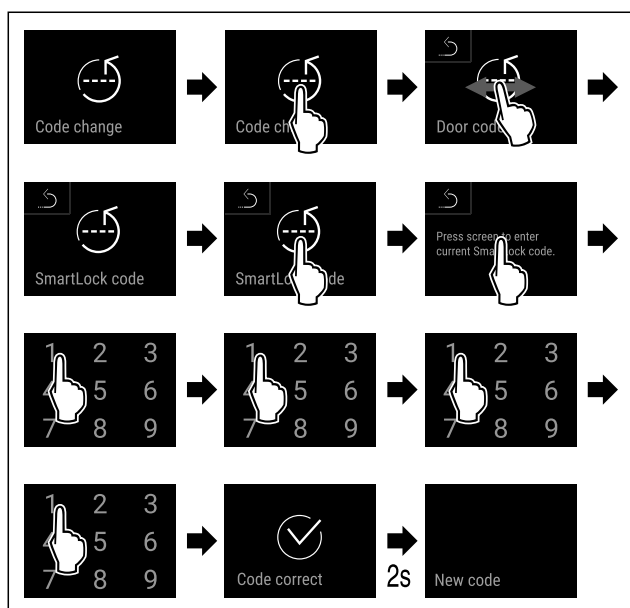

Fig. 91

- ▶ Carry out action steps according to the illustration.
- ▶ Entering the old SmartLock code is successful.

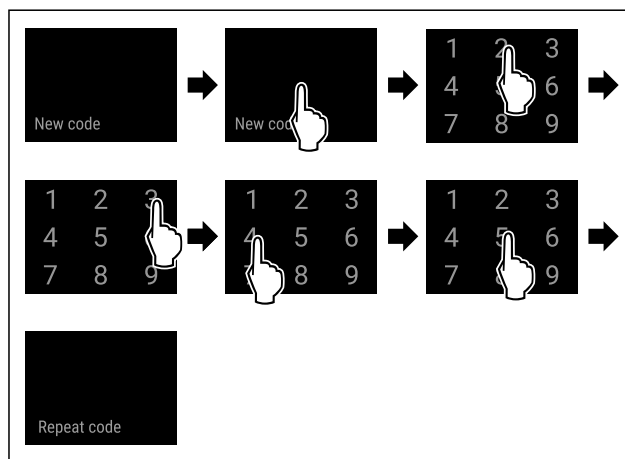

Fig. 92

- ▶ Carry out action steps according to the illustration.
- ▶ The new SmartLock code has been successfully entered.

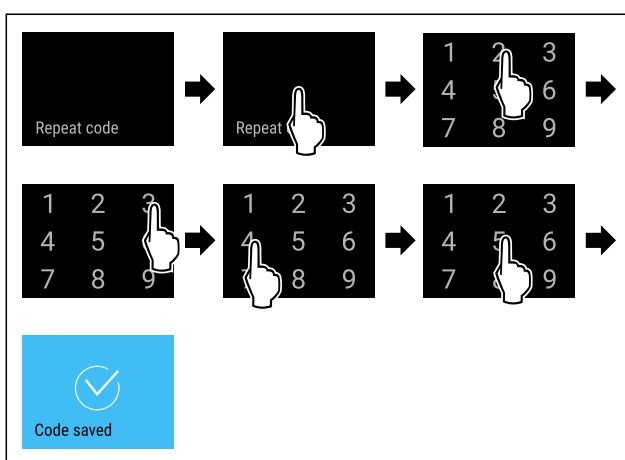

Fig. 93

- ▶ Carry out action steps according to the illustration.
- ▶ Confirmation of the new SmartLock code is successful.
- ▶ The SmartLock code has been changed.

Resetting SmartLock code

If you no longer know the SmartLock code, you can reset it.

- ▶ Reset appliance to factory settings. (see 6.2.22 Resetting to factory settings)

- ▶ The appliance has been reset to its original settings.
- ▶ The factory-set SmartLock code is: **1 1 1 1**

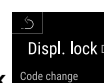

Code for the display lock

This function allows the display lock code to be changed or reset.

Changing the display lock code

The code can be changed in three steps:

- Enter old code.
- Enter new code.
- Confirm new code.

Note

In the following example, you change the factory-set code **1 1 1 1** to the new code **2 3 4 5**.



Fig. 94

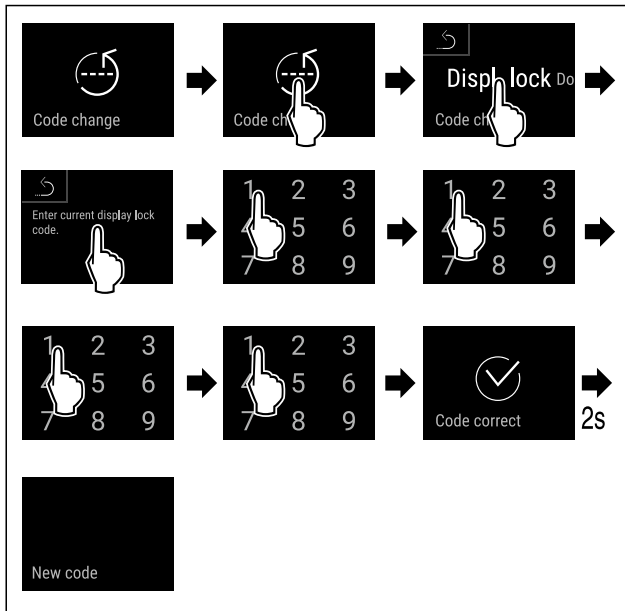

Fig. 95

- ▶ Carry out action steps according to the illustration.
- ▶ Entering the old code is successful.

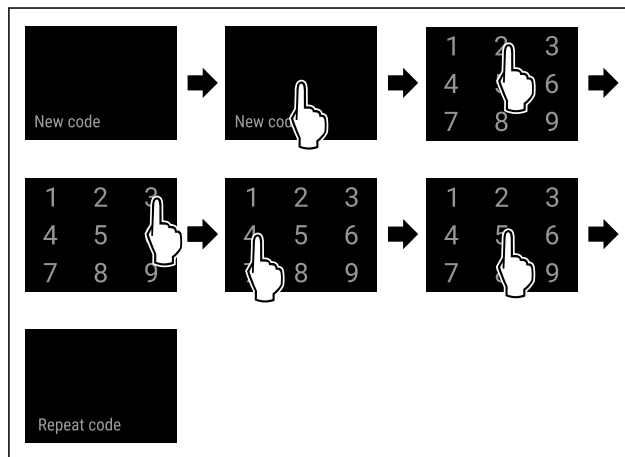

Fig. 96

- ▶ Carry out action steps according to the illustration.
- ▶ The new code has been successfully entered.

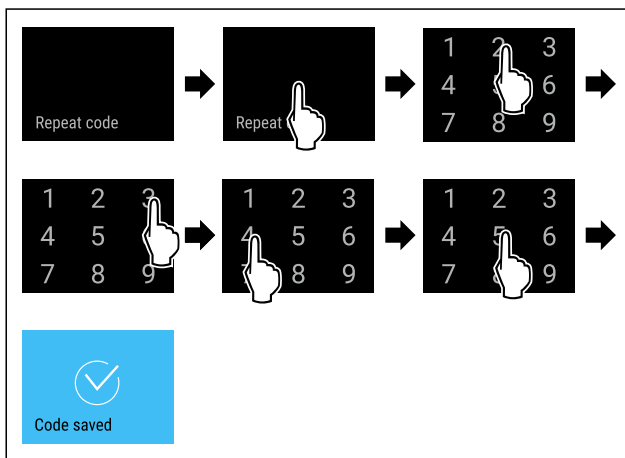

Fig. 97

- ▶ Carry out action steps according to the illustration.
- ▶ Confirmation of the new code is successful.
- ▶ The code has been changed.

Resetting the display lock code

If you no longer know the code, you can reset it.

- ▶ Reset appliance to factory settings. (see 6.2.22 Resetting to factory settings)
- ▶ The appliance has been reset to its original settings.
- ▶ The factory-set code is: **1 1 1 1**



6.2.17 Language

This setting allows the display language to be set.

Setting language

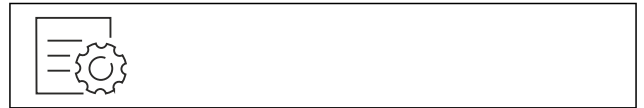

Fig. 98

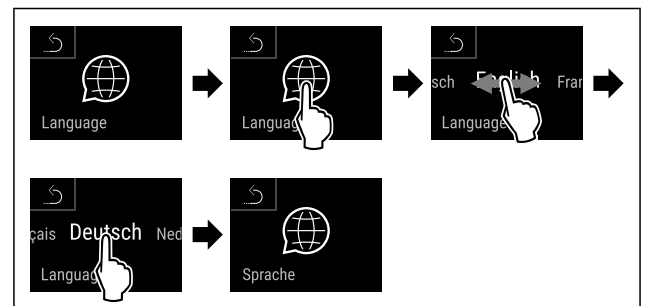

Fig. 99

- ▶ Carry out action steps according to the illustration.
- ▶ The selected language is set.

6.2.18 Device information

Use this function to indicate the model name, index, serial number and service number of your device. You will need the device information when you contact customer service. (see 9.4 Customer Service)

This function also opens the Advanced menu. (see 2 Functionality of the Touch & Swipe display)



Indicating the device information



Fig. 100



Fig. 101

- ▶ Carry out action steps according to the illustration.
- ▶ Display indicates device information.

6.2.19 Software

Use this function to indicate the software version of your device.



Indicating the software version



Fig. 102

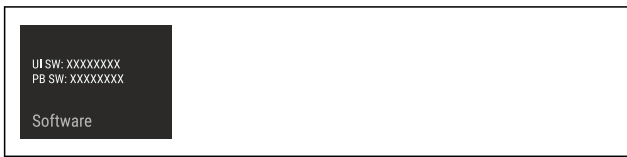

Fig. 103

- ▶ Carry out action steps according to the illustration.
- ▶ Display indicates software version.

6.2.20 Reminder



Use this function to activate or deactivate the reminder to change the FreshAir activated carbon filter.

Deactivating the reminder

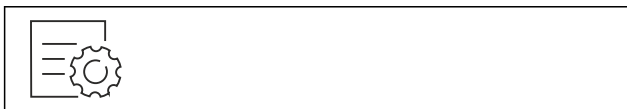

Fig. 104

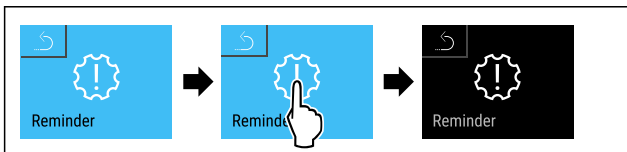

Fig. 105

- ▶ Carry out steps according to the illustration.
- ▶ Reminder is deactivated.

Activating the reminder

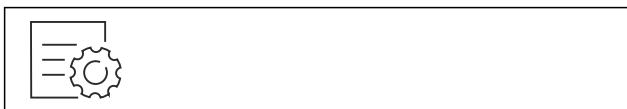

Fig. 106

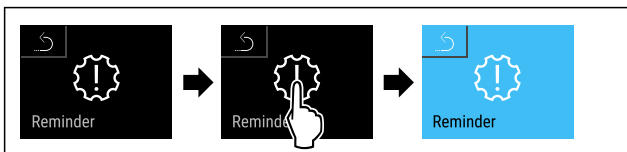

Fig. 107

- ▶ Carry out steps according to the illustration.
- ▶ Reminder is activated.

6.2.21 Demo mode



Demo mode is a special feature for dealers who want to demonstrate appliance features. If you activate demo mode, all refrigeration functions are deactivated.

If you switch on your appliance and a “D” appears on the status display, demo mode is already activated.

If you activate and then deactivate demo mode, the appliance will be reset to factory defaults. (see 6.2.22 Resetting to factory settings)

Activating demo mode



Fig. 108

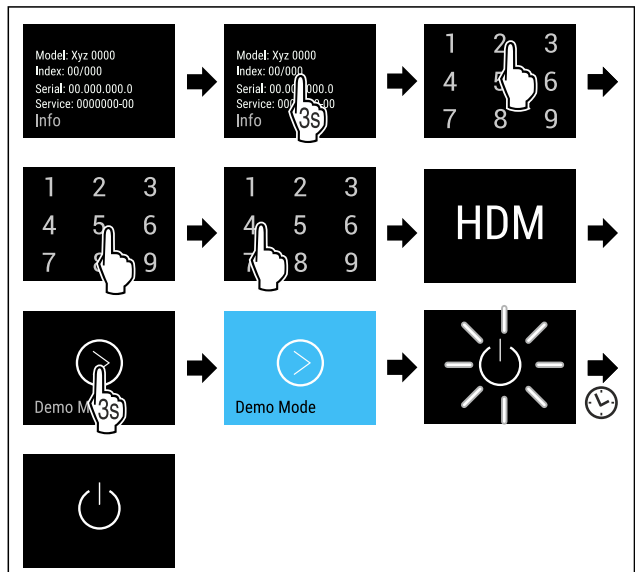

Fig. 109

- ▶ Carry out action steps according to the illustration.
- ▶ Demo mode is activated.
- ▶ Appliance is switched off.
- ▶ Switch on the appliance. (see 3.1 Switching on appliance (first use))
- ▶ “D” appears in the status display.

Deactivating demo mode



Fig. 110

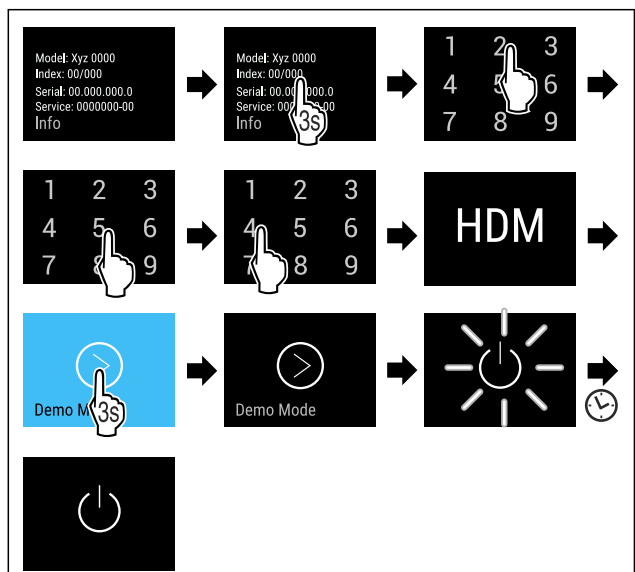

Fig. 111

- ▶ Carry out action steps according to the illustration.
- ▶ Demo mode is deactivated.
- ▶ Appliance is switched off.
- ▶ Switch on the appliance. (see 3.1 Switching on appliance (first use))
- ▶ Appliance is reset to factory settings.

6.2.22 Resetting to factory settings



Use this function to reset all settings to factory defaults. All settings you have made so far are reset to their original settings.

Performing a reset



Fig. 112

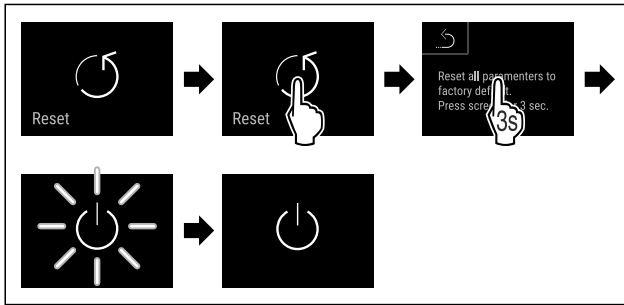

Fig. 113

- ▶ Carry out action steps according to the illustration.
- ▶ Device is reset.
- ▶ Device is switched off.
- ▶ Restart the device. (see 3.1 Switching on appliance (first use))



6.3 Message

6.3.1 Warnings

Warnings are issued by means of an acoustic signal and visually via a symbol on the display. The signal gets louder until the warning is acknowledged.

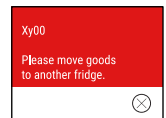

Message (red)	Cause	Remedy
 Close the door Door open	This message appears if the door is open for too long.	Close the door. Tap briefly. Alarm is stopped. Note The time until the message appears can be set. (see 6.2.10 Door alarm)
 Temperature alarm Temperature alarm	This message appears if the temperature does not match the set temperature. Reasons for differences in temperature can be: Warm produce for cooling has been placed inside. Too much warm air has got in while you were sorting out the freezer or removing items. The power was cut off for a prolonged period.	Tap briefly. Information about errors and appliance status are displayed. Tap briefly. Warmest/coldest temperature, date and time are displayed. Tap briefly. The status screen is displayed. The current temperature and the alarm symbol flash red until the set temperature is reached. Check the quality of the refrigerated goods.
 Device failure Error	The appliance is faulty, there is an appliance error or a component of the appliance has a fault.	Store the cooled produce elsewhere. Tap briefly. The error code (e.g. BT021) is displayed. Tap briefly. A further error code is displayed if there is one or Status screen is displayed with flashing error symbol. Swiping or tapping the display will show the error code(s) again. Make a note of error code(s) and contact Customer Service. (see 9.4 Customer Service)

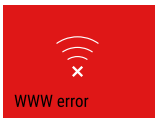

Message (red)	Cause	Remedy
 <p>Power cut</p>	The message appears following an interruption to the electricity supply.	Tap briefly. Battery's state of charge, information about errors and appliance status are displayed Tap briefly. The warmest temperature and the period of power interruptions are displayed. Tap briefly. The status screen is displayed. The current temperature and the alarm symbol flash red until the set temperature is reached. Check the quality of the refrigerated goods.
 <p>WiFi error</p>	Wi-Fi connection is interrupted.	Check connection. Press briefly. Alarm is stopped.
 <p>WWW error, WiFi</p>	This message appears if there is no internet connection via WiFi.	Check connection. Press briefly. Alarm is stopped.

6.3.2 Reminders

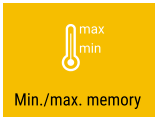
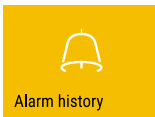
Reminders appear when you are being asked to do something. They are issued by means of an acoustic signal and visually via a symbol on the display. Acknowledge the message by pressing the confirmation button.

Message (yellow)	Cause	Remedy
 <p>Recording reminder</p>	The message appears when the temperature recording memory (999 hours) is full.	Press briefly. Reminder is closed. The oldest data is overwritten. Note The temperature recording can be reset.
 <p>Alarm log</p>	The message appears if there are more than 10 unconfirmed alarm messages.	Press briefly. Check messages. Reminder is closed.
 <p>Manually opened</p>	This message appears if a door which has been locked electronically is manually opened.	Close the door. Press briefly. Enter the door code to close it again. Reminder is closed.
 <p>ReplaceFreshAir activated charcoal filter</p>	The message appears every 6 months.	ReplaceFreshAir activated charcoal filter, Press briefly. Reminder is closed.

7 Features

7.1 Safety lock

The appliance door is fitted with an electronic lock.

Application:

- Lock and unlock with door code. (see 6.2.14 Door lock)

- Activate and deactivate automatic locking. (see 6.2.14 Door lock)
- Lock and unlock door with remote control.
- Door locks automatically after a power failure (cannot be deactivated).

Features

7.1.1 Emergency unlocking

If there is a power failure, the door can be opened with the emergency release key.

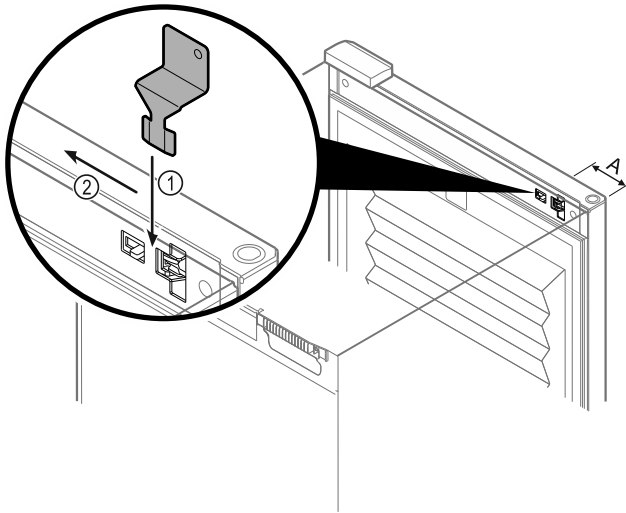

Fig. 114

- ▶ Insert the emergency release key in the specified position Fig. 114 (A) \approx 100 mm.
- ▶ Insert the emergency release key Fig. 114 (1) between the door and the body of the appliance from above to the end stop.
- ▶ Pull the emergency release key towards the hinge. Fig. 114 (2)
- ▶ The lock is unlocked. You can open the door.

7.2 Wooden grid

The appliances are equipped with a wooden grid for wine storage.

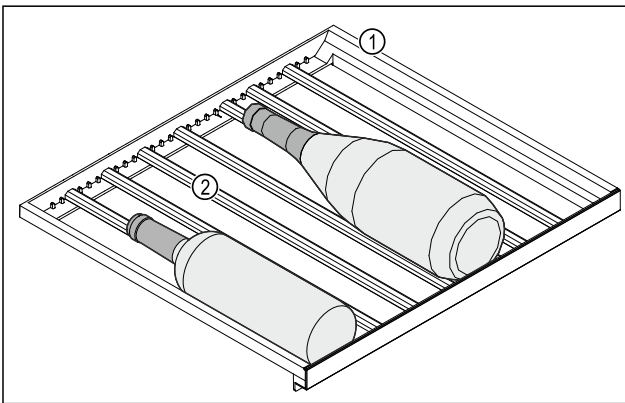

Fig. 115 Example illustration

(1) Wooden grid (2) Bar

The standard positions for the bars are indicated by notches. If you use these, you can store the maximum number of bottles. (see 4.2 Storage sketches)

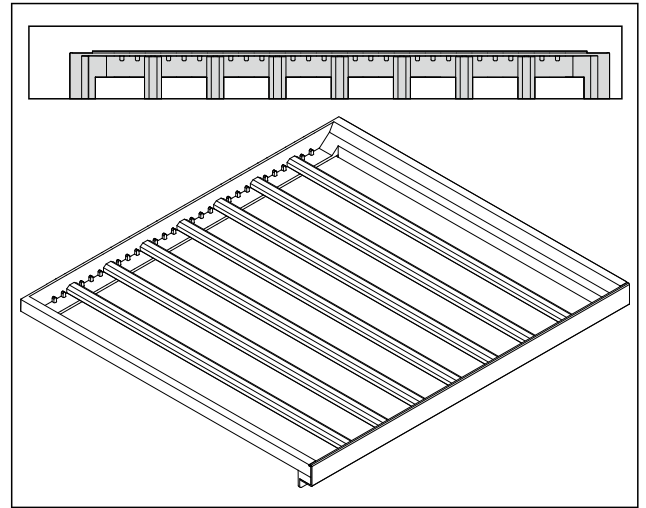

Fig. 116 Arrangement of the bars for maximum number of bottles.

7.2.1 Moving the bar

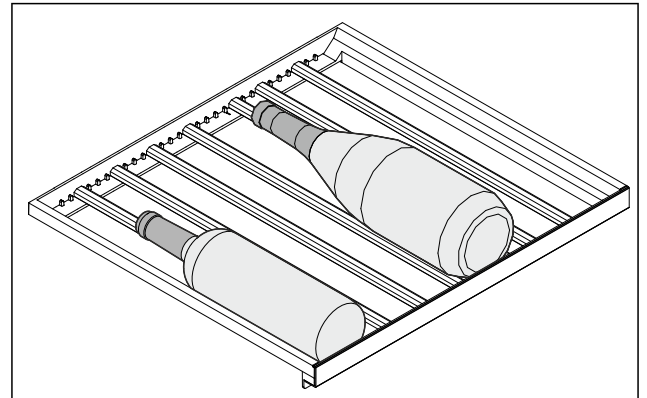

Fig. 117 Example illustration

You can remove the bars in the wooden rack to store larger or smaller bottles.

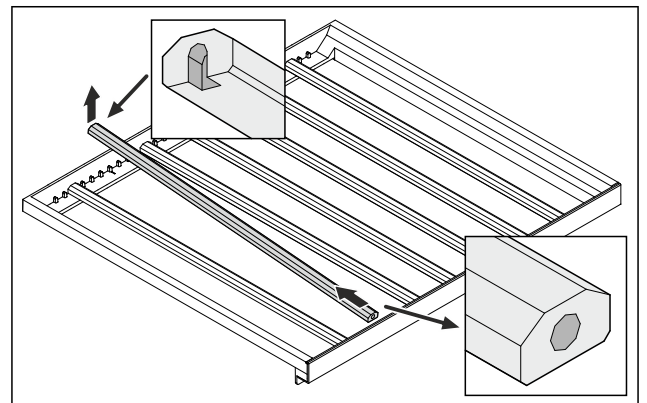

Fig. 118 Example illustration

- ▶ Lift and pull out the bar at the rear.

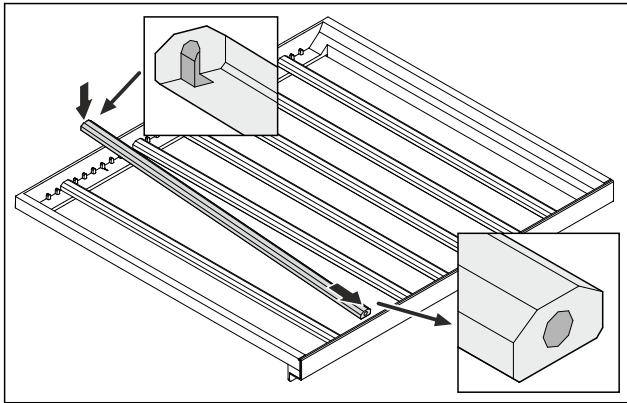

Fig. 119 Example illustration

- ▶ Insert the bar in the desired position.

7.3 Labels

Description labels as accessories can be purchased from your specialist dealer. You can use these to note the types of wine that are stored in the respective compartment.

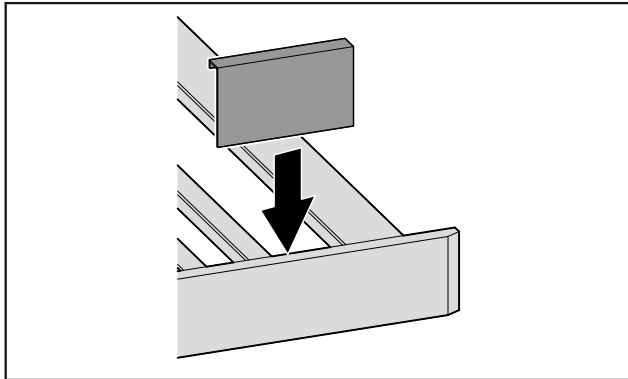

Fig. 120

- ▶ Attach the label from above.

7.4 Water box*

You can increase the humidity in your wine appliance by using the water box.

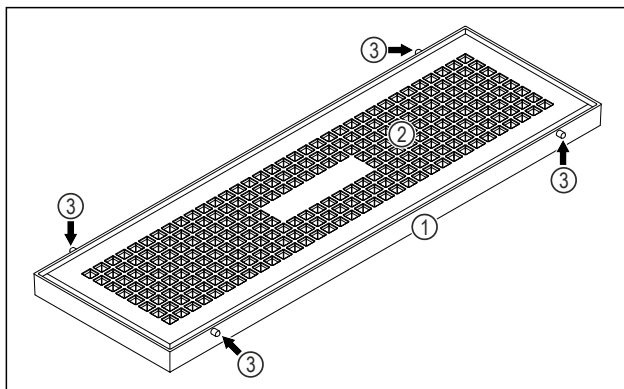

Fig. 121 Example illustration, Water box

- (1) Water tray
- (2) Cover
- (3) Peg

7.4.1 Filling the water box with water

Ensure that the following requirements are met:

- Water box has been removed. (see 7.4.3 Taking out the water box)
- Water box is horizontal.

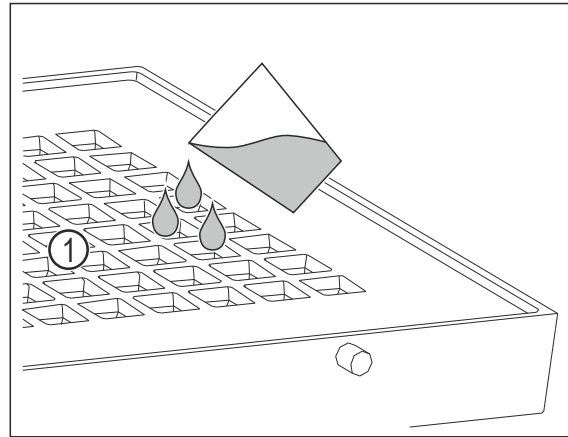

Fig. 122

- ▶ Fill with a maximum of 400 ml of water through the holes Fig. 122 (1) in the cover.

7.4.2 Inserting the water box

You can use the WaterBox on a wooden wine rack in the lowest wine zone.

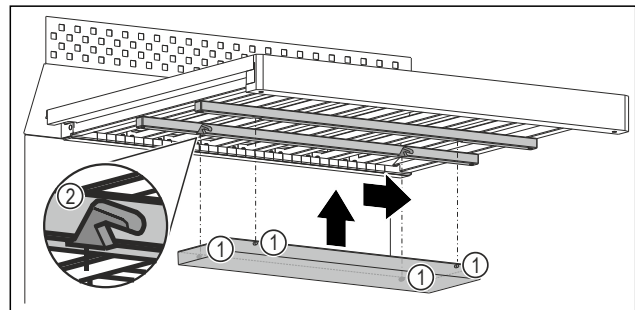

Fig. 123 Example illustration

- ▶ Insert each peg Fig. 123 (1) into the corresponding recess Fig. 123 (2) on the strips under the wooden grate.
- ▶ Push the water box to the right.
- ▶ Check that the water box is horizontal and that the pegs are in the corresponding recesses.

7.4.3 Taking out the water box

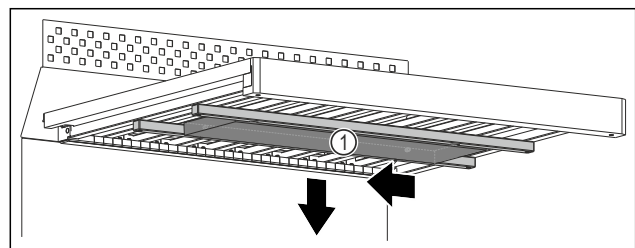

Fig. 124

- ▶ Push the water box Fig. 124 (1) to the left.
- ▶ Remove the water box Fig. 124 (1) downwards.

7.4.4 Dismantling the water box

You can remove the water box for cleaning.

Ensure that the following requirements are met:

- Water box has been removed. (see 7.4.3 Taking out the water box)
- The water box is completely empty.

Maintenance

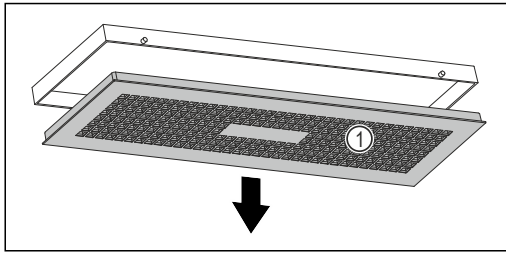

Fig. 125

- ▶ Slowly turn the water box down while holding the cover Fig. 125 (1).
- ▶ Remove the cover Fig. 125 (1).

8 Maintenance

8.1 FreshAir activated carbon filter

Wine is constantly developing according to its ambient conditions, so air quality is essential for preservation.

The FreshAir activated charcoal filter guarantees optimal air quality.

- Change the activated charcoal filter every 6 months.
- Dispose of the activated charcoal filter with regular household waste.

Note

FreshAir activated charcoal filters can be purchased from the Liebherr-Hausgeräte store at home.liebherr.com/shop/de/deu/zubehor.html.

8.1.1 Replacing the FreshAir activated charcoal filter

Must be carried out multiple times depending on the equipment.

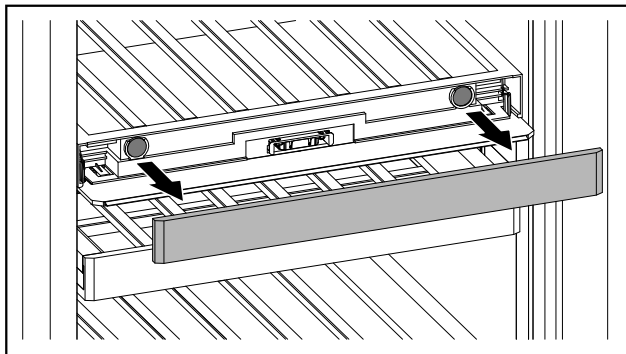

Fig. 126

- ▶ Remove the panel.

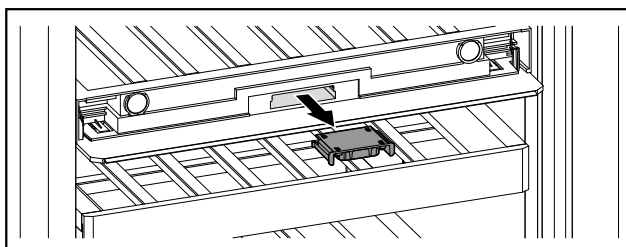

Fig. 127

- ▶ Pull the drawer out.

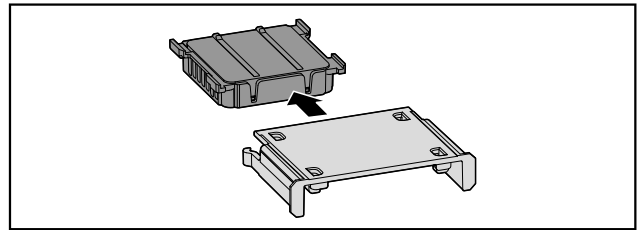

Fig. 128

- ▶ Pull out the filter.

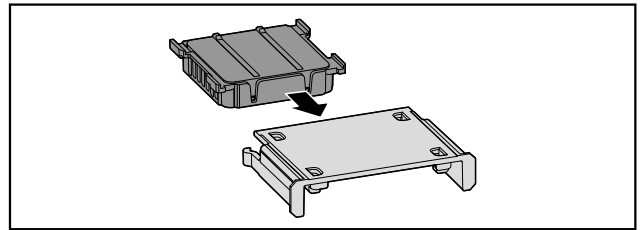

Fig. 129

- ▶ Insert the new filter.

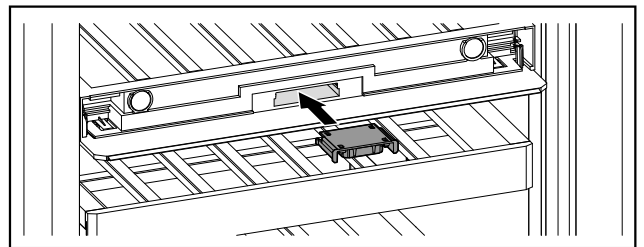

Fig. 130

- ▶ Push the drawer in.

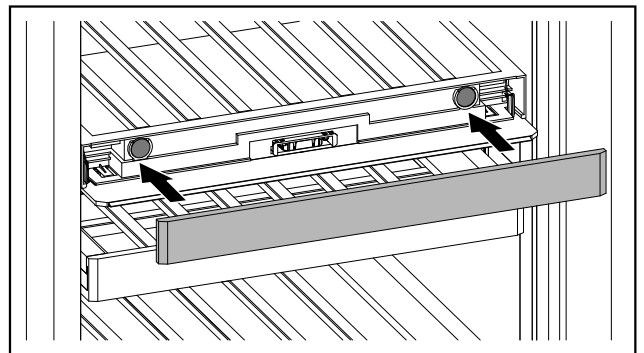

Fig. 131

- ▶ Set the panel back in place.

8.2 Cleaning the appliance

8.2.1 Ready



WARNING

Danger of electric shock!

- ▶ Remove the refrigerator connector or interrupt the power supply.



WARNING

Risk of fire

- ▶ Do not damage the refrigeration circuit.

- ▶ Empty the appliance.
- ▶ Remove mains connector.

8.2.2 Clean the housing

NOTICE

Improper cleaning!

Damage to the appliance.

- ▶ Only use soft cleaning cloths and ph-neutral all-purpose cleaners.
- ▶ Do not use abrasive sponges or steel wool which may cause scratches.
- ▶ Do not use any sharp or abrasive cleaning agents, nor any that contain sand, chloride or acid.



WARNING

Risk of injury and damage as a result of hot steam!

Hot steam can lead to burns and can damage the surfaces.

- ▶ Do not use any steam cleaners!

- ▶ Wipe the housing down with soft, clean cloth. If very dirty, use lukewarm water with a neutral cleaner. Glass surfaces can also be cleaned with glass cleaner.

8.2.3 Cleaning the interior

NOTICE

Improper cleaning!

Damage to the appliance.

- ▶ Only use soft cleaning cloths and ph-neutral all-purpose cleaners.
- ▶ Do not use abrasive sponges or steel wool which may cause scratches.
- ▶ Do not use any sharp or abrasive cleaning agents, nor any that contain sand, chloride or acid.

- ▶ Plastic surfaces: clean by hand with a soft clean cloth, lukewarm water and a little detergent.
- ▶ Metal surfaces: clean by hand with a soft clean cloth, lukewarm water and a little detergent.

8.2.4 Cleaning the equipment

NOTICE

Improper cleaning!

Damage to the appliance.

- ▶ Only use soft cleaning cloths and ph-neutral all-purpose cleaners.
- ▶ Do not use abrasive sponges or steel wool which may cause scratches.
- ▶ Do not use any sharp or abrasive cleaning agents, nor any that contain sand, chloride or acid.

Cleaning with a damp, lint-free cloth:

- Bottle shelf
- ▶ Clean the equipment.

8.2.5 After cleaning

- ▶ Wipe the appliance and the components dry.
- ▶ Connect and switch on the appliance.
- ▶ Repeat cleaning regularly.

9 Customer help

9.1 Technical specifications

Temperature range	
Cooling	5 °C to 20 °C

Maximum loading weight for the bottle rack	
Bottle shelf	60 kg
Bottle rack with telescopic rails	25 kg

For appliances with a WiFi connection:

Frequency specification	
Frequency band	2.4 GHz
Maximum radiated power	< 100 mW
Purpose of the wireless equipment	Integration in the local WiFi network for data communication

9.2 Operating noises

The appliance makes different noises when it is on.

- At **higher temperatures** the appliance uses less energy but works for longer. It is **quieter**.
- At **lower temperatures** the food is cooled faster. It is **louder**.

Examples:

- Functions on (see 6.2 Appliance functions)
- Fan running
- Food recently added
- High ambient temperature
- Door open for a while

Noise	Possible cause	Type of noise
Bubbling and splashing	Coolant flowing into the cooling circuit.	Normal operating noise
Hissing	Coolant sprays into the cooling circuit.	Normal operating noise
Humming	The appliance is cooling. The volume depends on the cooling output.	Normal operating noise
Suction noises	Soft-closing door is being opened and closed.	Normal operating noise
Humming and rustling	The fan is running.	Normal operating noise
Clicking	Components are switched on and off.	Normal switching noise
Rattling or humming	Valves or flaps are working.	Normal switching noise

Noise	Possible cause	Type of noise	Lifting
Vibration	Improper setup	Defective noise	Level the appliance using the adjustable feet.

Noise	Possible cause	Type of noise	Lifting
Rattling	Components, items inside the appliance	Defective noise	Secure components. Leave enough space between the items.

9.3 Technical fault

Your appliance is designed and built to ensure it works reliably and has a long service life. In the unlikely event that a fault occurs during operation, please check whether it is due to an operating error. If so, you will be charged for the callout and repair costs even if it falls within the warranty period.

You can fix the following faults yourself.

9.3.1 Appliance function

Defect	Cause	Remedy
The appliance is not working.	→ The appliance is not switched on.	▶ Switch the appliance on.
	→ The power plug is not properly plugged into the socket.	▶ Check the power plug.
	→ There is something wrong with the power outlet fuse.	▶ Check the fuse.
	→ Power cut	▶ Keep the appliance closed.
	→ The IEC socket is not plugged into the appliance correctly.	▶ Check the IEC socket.
Temperature is not cold enough.	→ The appliance door is not closed properly.	▶ Close the appliance door.
	→ The ambient temperature is too high.	▶ Problem solution: (see 1.4 Appliance range of use)
	→ The appliance was opened too many times or for too long.	▶ Wait to see if the required temperature corrects itself. If not, contact Customer Service. (see 9.4 Customer Service)
	→ The temperature is set incorrectly.	▶ Turn down the temperature and check after 24 hours.
	→ The appliance is too close to a heat source (oven, radiator, etc).	▶ Move the appliance or the heat source.
The door seal is defective or needs to be replaced for another reason.	→ The door seal can be replaced. It can be replaced without the need for special tools.	▶ Contact Customer Service. (see 9.4 Customer Service)
The appliance builds up too much ice or condensation.	→ The door seal may have slipped out of its groove.	▶ Check that the door seal is well fitted in the groove.
The exterior surfaces of the appliance are warm.*	→ The heat of the refrigeration circuit is used to avoid condensation.	▶ This is normal.

9.3.2 Features

Defect	Cause	Remedy
Mould on the wine bottles	→ Similar to other types of bearing, a slight layer of mould can form depending on the type of adhesive used for the label.	▶ Remove any adhesive residues.
The internal light does not come on.	→ The appliance is not switched on.	▶ Switch the appliance on.
	→ The door was open for longer than 15 minutes.	▶ Interior lighting switches off automatically after about 15 minutes when the door is open.

Defect	Cause	Remedy
	→ The LED interior light is faulty or the lid is damaged.	▶ Contact Customer Service. (see 9.4 Customer Service)

9.4 Customer Service

First check whether you can rectify the fault yourself (see 9 Customer help) . If you cannot rectify the problem, contact Customer Service.

You can find the address at home.liebherr.com/service.



WARNING

Unprofessional repair!
Injuries.

- ▶ Have any repairs and action - not expressly specified - on the appliance and mains cable carried out by service personnel only. (see 8 Maintenance)
- ▶ A damaged mains cable may only be replaced by the manufacturer, the manufacturer's Customer Service or a similarly qualified person.
- ▶ In the case of appliances with an IEC connector, the change may be made by the customer.

- ▶ Switch off appliance. (see 6.2.2 Switching appliance on and off)
- ▶ Pull the mains plug out of the socket.
- ▶ Remove the IEC socket if required: Pull the IEC socket out of the appliance plug and move it to the left and right at the same time.
- ▶ Clean appliance. (see 8.2 Cleaning the appliance)
- ▶ Leave the door open, so that no unpleasant odours arise.

9.4.1 Contacting Customer Service

Make sure that the following appliance information is available:

- Appliance name (model and index)
- Service no. (Service)
- Serial no. (S no.)
- ▶ Call up the appliance information via the display.
- or-
- ▶ Refer to the type plate for appliance information. (see 9.5 Model plate)
- ▶ Note down the appliance information.
- ▶ Notify customer service: Report errors and the appliance information.
- ▶ This will help us to provide you with a faster, more accurate service.
- ▶ Follow further instructions from Customer Service.

9.5 Model plate

The type plate is located on the bottom left of the inside of the appliance.

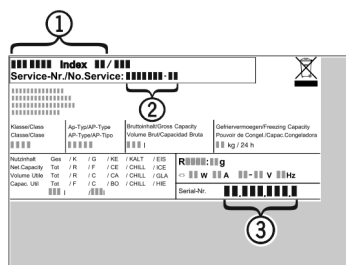

Fig. 132

- (1) Appliance description (3) Serial no.
(2) Service no.

- ▶ Note the data on the model plate.

10 Shutting down

- ▶ Empty the appliance.



home.liebherr.com/fridge-manuals

EN wine cooling cabinet

Issue date: 20260319

Part number index: 7083584-00

Liebherr-Hausgeräte Marica EOOD
Bezirk Plovdiv
4202 Radinovo
Bulgarien