

Operating and installation instructions



[home.liebherr.com/
fridge-manuals](https://home.liebherr.com/fridge-manuals)

LIEBHERR

EN

ORIGINAL OPERATOR'S MANUAL

LIEBHERR







Contents

| | | |
|----------|--------------------------------------------------------------|-----------|
| 1 | Safety information and warnings..... | 3 |
| 1.1 | Intended use..... | 3 |
| 1.2 | Climate classes..... | 3 |
| 1.3 | User group..... | 3 |
| 1.4 | Installation and commissioning..... | 3 |
| 1.5 | Safe handling of the appliance..... | 3 |
| 1.6 | Cleaning..... | 4 |
| 1.7 | Faults, damage and repairs..... | 4 |
| 1.8 | Disposal..... | 4 |
| 1.9 | Conformity..... | 4 |
| 1.10 | SVHC substances in accordance with the REACH Regulation..... | 4 |
| 1.11 | EPREL database..... | 4 |
| 1.12 | Open source licences..... | 4 |
| 1.13 | Spare parts..... | 4 |
| 1.14 | Symbols on the appliance..... | 4 |
| 1.15 | Warning levels..... | 5 |
| 2 | Appliance at a glance..... | 5 |
| 2.1 | Scope of delivery..... | 5 |
| 2.2 | Overview of the appliance and equipment..... | 5 |
| 2.3 | SmartDevice..... | 5 |
| 3 | Setting up and connecting..... | 6 |
| 3.1 | Installation requirements..... | 6 |
| 3.2 | Appliance dimensions..... | 6 |
| 3.3 | Recess dimensions..... | 7 |
| 3.4 | Custom panel weights..... | 7 |
| 3.5 | Transporting the appliance..... | 7 |
| 3.6 | Unpacking the appliance..... | 7 |
| 3.7 | Explanation of symbols used..... | 8 |
| 3.8 | Reversing the door..... | 8 |
| 3.9 | Setting up the appliance..... | 10 |
| 3.10 | Installing multiple appliances..... | 10 |
| 3.11 | Disposing of packaging..... | 11 |
| 3.12 | Installing the appliance in the recess..... | 11 |
| 3.12 | Cabinet fronts..... | 17 |
| 3.13 | Dimensions..... | 17 |
| 3.14 | Mounting the cabinet front(s)..... | 18 |
| 3.15 | Setting the clearance to avoid collision..... | 18 |
| 3.16 | Connecting the appliance to the power supply..... | 19 |
| 4 | Functionality of the Touch display..... | 19 |
| 4.1 | Navigation and symbol explanation..... | 19 |
| 4.2 | Menus..... | 20 |
| 4.3 | Sleep mode..... | 20 |
| 5 | Putting into operation..... | 21 |
| 5.1 | Switching on appliance (first use)..... | 21 |
| 6 | Storage..... | 21 |
| 6.1 | Information regarding storage..... | 21 |
| 6.2 | Fridge compartment..... | 21 |
| 6.3 | EasyFresh..... | 21 |
| 6.4 | Cellar compartment..... | 21 |
| 6.5 | ****-freezer compartment..... | 22 |
| 6.6 | Storage times..... | 22 |
| 7 | Saving energy..... | 22 |
| 8 | Controls..... | 23 |
| 8.1 | Controls and displays..... | 23 |
| 8.1.1 | Status display..... | 23 |
| 8.1.2 | Display symbols..... | 23 |
| 8.2 | Appliance functions..... | 23 |
| 8.2.1 | Notes on the appliance functions..... | 23 |
| | Switching the appliance off and on..... | 23 |
| | Switching temperature zone off and on..... | 23 |
| | Temperature..... | 24 |

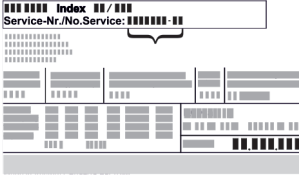

| | |
|----------------------------------------------------------------------------|-----------|
| SuperCool..... | 24 |
| PartyMode | 25 |
| HolidayMode..... | 25 |
| SabbathMode..... | 26 |
| E-Saver | 26 |
| CleaningMode..... | 27 |
| Input lock..... | 27 |
| Temperature unit..... | 28 |
| Display brightness..... | 28 |
| WiFi..... | 28 |
| Device information..... | 29 |
| Software..... | 29 |
| Door alarm..... | 30 |
| Demo mode..... | 30 |
| Resetting to factory settings..... | 31 |
| 8.3 Messages..... | 31 |
| 8.3.1 Overview of warnings..... | 31 |
| 8.3.2 Ending warnings..... | 31 |
| 8.3.3 Overview of reminders..... | 32 |
| 9 Features..... | 32 |
| 9.1 4-star freezer compartment..... | 32 |
| 9.2 Door rack..... | 32 |
| 9.3 Shelves..... | 32 |
| 9.4 Dividing shelf..... | 33 |
| 9.5 Drawers..... | 33 |
| 9.6 Compartment lid for EasyFresh Safe..... | 35 |
| 9.7 Pull-out unit..... | 35 |
| 9.8 Bottle holder..... | 36 |
| 9.9 FlexCube..... | 36 |
| 10 Maintenance..... | 37 |
| 10.1 Removing / inserting the bottle holder..... | 37 |
| 10.2 Disassembling / assembling pull-out systems..... | 37 |
| 10.3 Compartment lid for EasyFresh Safe..... | 38 |
| 10.4 Defrosting the appliance..... | 38 |
| 10.5 Cleaning the appliance..... | 38 |
| 11 Customer help..... | 39 |
| 11.1 Technical specifications..... | 39 |
| 11.2 Operating noises..... | 39 |
| 11.3 Technical fault..... | 39 |
| 11.4 Customer Service..... | 40 |
| 11.5 Model plate..... | 41 |
| 12 Shutting down..... | 41 |
| 13 Disposal..... | 41 |
| 13.1 Preparing the appliance for disposal..... | 41 |
| 13.2 Disposing of the appliance in an environmentally friendly manner..... | 41 |

The manufacturer is continually working on the further development of all types and models. Please be aware that we reserve the right to make changes to the shape, equipment and technology.

| Symbol | Explanation |
|------------------------------------------------------------------------------------|---------------------------------------------------------------------------------------------------------------------------------------------------------------------------------------------------------------------------------------------------------------------------------------------------------------------------------------------------------------------------------------------------------------------------------------------------------------------------------------------------------------------------------------|
|  | Read instructions Please read the information in these instructions carefully to understand all of the benefits of your new appliance. |
|  | Additional information on the Internet The digital manual with additional information and in other languages can be found via the QR code on the front of the manual or by entering the service number at home.liebherr.com/fridge-manuals . The service number can be found on the serial tag: <div style="text-align: center;">  <p><i>Fig. Example illustration</i></p> </div> |
|  | Check appliance Check all parts for transport damage. If you have any complaints, please contact your agent or customer service. |
|  | Differences These instructions apply to a range of models, so differences are possible. Sections that apply to certain models only are marked with an asterisk (*). |
|  | Instructions and results Instructions are marked with a ►. Results are marked with a ▷. |
|  | Videos Videos about the appliances are available on the YouTube channels of Liebherr-Hausgeräte. |

Open source licences:

The appliance contains software components that use open source licences. Information on the open source licences used can be found here: home.liebherr.com/open-source-licences

This user information applies to the following appliances:

| | |
|-------|------|
| IRC.. | 51.. |
|-------|------|

1 Safety information and warnings

Keep this user information in a safe place so that you can refer to it at any time.

If you pass on the appliance, pass this user information on to subsequent owners.

To use the appliance properly and safely, read this user information carefully before installation and use. Always follow the instructions, safety instructions and warnings contained therein. They are important so that you can install and operate the appliance safely and properly.

1.1 Intended use

- This appliance is intended for household use and similar applications such as:
 - in staff kitchen areas in shops, offices and other work areas
 - in agricultural environments and by guests in hotels, motels and other accommodation
 - in bed and breakfasts
 - in catering and similar wholesale operations
- Further uses:
 - All other types of application are impermissible.

1.2 Climate classes

Depending on its climate class, the appliance is designed for operation within certain ambient temperature limits. The climate class for your appliance is printed on the type plate.

Note

- In order to guarantee fault-free operation comply with the specified ambient temperatures.

| Climate class | for ambient temperatures from |
|---------------|-------------------------------|
| SN | 10 °C to 32 °C |
| N | 16 °C to 32 °C |
| ST | 16 °C to 38 °C |
| T | 16 °C to 43 °C |
| SN-ST | 10 °C to 38 °C |
| SN-T | 10 °C to 43 °C |

1.3 User group

- This appliance can be used by children aged from 8 years and above and persons with reduced physical, sensory or mental capabilities or lack of experience and knowledge if they have been given supervision or instruction concerning use of the appliance in a safe way and understand the hazards involved.
- Children must not play with the appliance.
- Children must not carry out cleaning and user maintenance without supervision.
- Children aged from 3 to 8 years are allowed to load and unload refrigerating appliances.

1.4 Installation and commissioning

- Only install and connect the appliance in accordance with the instructions in the user information.
- Install the appliance according to the instructions in the user information to prevent the appliance from tipping over.
- Do not close the ventilation openings in the appliance housing or in the installation housing.
- Do not damage the mains cable. The appliance must not be operated with a defective mains cable.
- Do not place portable multiple sockets or power supply units at the rear of the appliance.
- It must be easy to access the socket so that the appliance can be quickly disconnected from the power supply in case of an emergency. It must not be behind the appliance.

1.5 Safe handling of the appliance

- Do not store any explosive substances, such as aerosol containers with flammable propellant gas, in the appli-

Safety information and warnings

ance. These types of aerosol can be identified by the list of contents printed on it, or by a flame symbol. Any leaking gas may ignite due to electrical parts.

- Keep burning candles, lamps and other objects with naked flames away from the appliance, so that these do not set fire to the appliance.
- Alcoholic beverages and other containers bearing alcohol must be sealed tight for storage. Any leaking alcohol may ignite due to electrical parts.
- Avoid prolonged skin contact with cold surfaces or with cold/frozen food. Use gloves for protection, for example.
- The refrigerant contained (information on the type plate) is environmentally friendly but flammable. Leaking refrigerant may ignite.
 - Do not damage the refrigeration circuit.
 - Do not use any ignition sources inside the appliance.
 - Do not use electrical appliances inside the appliance (e.g. steam cleaners, heaters).
 - If the refrigerant leaks: remove any naked flames or ignition sources from the vicinity of the leakage point. Properly air the room. Inform customer service.
- Only open the door for a short time. This prevents the temperature inside the appliance from rising.
- Do not reach between the door and the appliance when opening and closing. Fingers may become trapped.
- The temperature in the warmest part of the appliance may be higher than the set temperature.

1.6 Cleaning

- Regularly clean surfaces that come into contact with food.
- Clean the defrost water drain regularly.
- Do not use an electric heater or steam cleaner, naked flames or defrost spray to speed up the defrosting process.
- Do not remove the ice with sharp objects.

1.7 Faults, damage and repairs

- If the mains connection cable of the appliance is damaged, replace the mains connection cable.
- Repairs and interventions on the appliance may only be carried out by the customer service or by other qualified personnel trained for this purpose.
- In the event of malfunctions and appliance faults, pull out the mains plug or switch off the fuse. Always hold the plug when pulling out the mains plug. Never tug on the cable.

1.8 Disposal

- The appliance contains valuable materials and is marked with the appropriate symbol. (see 1.14 Symbols on the appliance)
 - Do not dispose of the appliance in the household waste.
 - Dispose of the appliance free of charge at your local recycling centre using the Class 1 collection containers.
 - When purchasing a new appliance, return the old appliance to the retailer free of charge.
 - Provide information about return options.
- Your appliance may contain personal data.
 - Delete personal data before disposal.
- The appliance contains refrigerant (information on the type plate) and oil. The refrigerant inside the appliance is environmentally friendly, but flammable. The oil it contains is also flammable. Escaping refrigerant and oil

can ignite in high concentrations and in contact with an external heat source.

- Do not damage the refrigeration circuit.
- Only dispose of the appliance in accordance with the instructions in the user information.

1.9 Conformity

The coolant circuit has been tested for leak-tightness. When installed, the appliance complies with the relevant safety regulations and directives.

The full text of the EU Declaration of Conformity is available at the following web address: www.liebherr.com

1.10 SVHC substances in accordance with the REACH Regulation

- You can use the following link to check whether your appliance contains SVHC substances in accordance with the REACH Regulation: <https://go.liebherr.com/z3eewm>

1.11 EPREL database

- From 1 March 2021, the information on energy labelling and eco-design requirements will be available in the European product database (EPREL). The product database can be accessed via the following link <https://eprel.ec.europa.eu/>. Here, you are asked to enter the model identifier. You will find the model identifier on the type plate.



1.12 Open source licences

- The appliance contains software components that use open source licences. Information on the open source licences used can be found here: home.liebherr.com/open-source-licences

1.13 Spare parts

- The spare parts availability for functional parts and stockable parts of the equipment is 15 years.

1.14 Symbols on the appliance

| | |
|--------------------------------------------------------------------------------------|-----------------------------------------------------------------------------------------------------------------------------------------------------------------------------------------------------------------------------------------------------------------------------------------------------------------|
|  | This symbol may be found on the compressor. It pertains to the oil in the compressor and indicates the following danger: Can be fatal if swallowed or with penetration of the respiratory tract. This information is only significant for recycling. No risk exists with normal use. Do not remove this symbol. |
|  | Warning: Fire hazard due to flammable substances. This symbol is located on the compressor and can also be found in other places on the appliance. This symbol warns of flammable substances. Do not remove this symbol. |
|  | This or a similar symbol may be on the rear of the appliance. It indicates that there are vacuum insulation panels (VIP) or perlite panels in the door and/or housing. This information is only significant for recycling. Do not remove this symbol. |

Setting up and connecting

Downloading the SmartDevice app:



After installing and configuring the SmartDevice app, you can connect your appliance to your Wi-Fi (see WiFi) using the SmartDevice app and the appliance's Wi-Fi function.

Note

The SmartDevice function is not available in the following countries: Russia, Belarus, Kazakhstan.

You cannot use the SmartDeviceBox.

3 Setting up and connecting

3.1 Installation requirements

The installation conditions are crucial to ensure that you can operate your appliance safely, efficiently and without problems.

- Observe all safety instructions.
- Consider the location and position in the room.



WARNING

Danger of fire due to incorrect positioning!

If the mains cable or plug touches the back of the appliance, the vibration can damage the mains cable or the plug resulting in a short circuit.

- ▶ Make sure the mains cable is not trapped under the appliance when you position the appliance.
- ▶ Stand the appliance so that it is not touched by connectors or main cables.
- ▶ Do not connect any appliances to sockets in the area of the back of the appliance.
- ▶ Do **not** place and operate multi-sockets/power distributors and other electronic devices (such as halogen transformers) at the back of the appliances.



WARNING

Fire hazard due to dampness!

If live parts or the mains lead become damp this may cause short circuits.

- ▶ The appliance is designed for use in enclosed areas. Do not operate the appliance outdoors or in areas where it is exposed to splash water or damp conditions.



WARNING

Leaking coolant and oil!

Fire. The coolant contained in the appliance is eco-friendly, but also flammable. The oil contained in the appliance is flammable. Escaping coolant and oil can ignite if the concentration is high enough and in contact with an external heat source.

- ▶ Do not damage the pipelines of the coolant circuit and the compressor.

3.1.1 Installation site

- Only set up and use the appliance in enclosed spaces.
- Only operate the appliance when it is installed.

- If the appliance is installed in a very damp environment, condensation may form on the appliance exterior. Always make sure there is good ventilation and aeration at the installation site.
- The more refrigerant there is in the appliance, the larger the room must be in which it is located. In rooms that are too small, a leak can produce a flammable gas/air mixture. For every 8 g of refrigerant, the installation room must be at least 1 m³ in size. Information on the refrigerant contained is given on the type plate inside the appliance.
- The floor on which the appliance stands must be horizontal and level.

3.1.2 Position in space

- Do not install the appliance in direct sunlight or near radiators or similar sources of heat.
- You can install the appliance directly next to an oven.
- If the appliance is installed directly next to an oven, the energy consumption may increase slightly. This is dependent on the service life and usage intensity of the oven.
- Only fit the appliance into solid units.
- Use in hazardous areas is not permitted.

3.2 Appliance dimensions

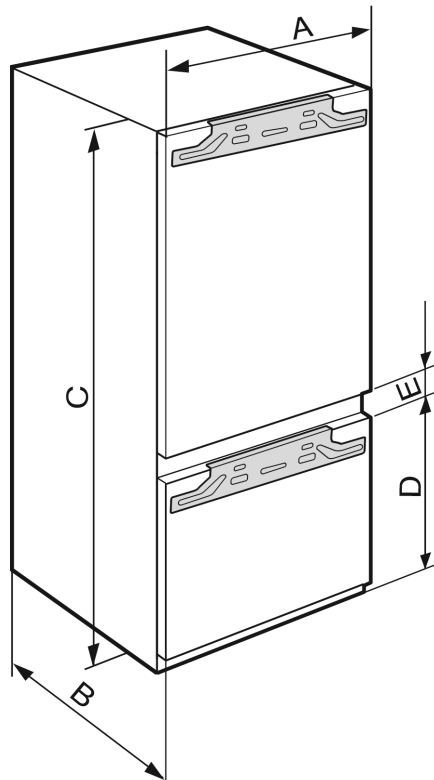

Fig. 2

| IRC(B).. 51.. | |
|---------------|------|
| A (mm) | 559 |
| B (mm) | 546 |
| C (mm) | 1770 |
| D (mm) | 612 |
| E (mm) | 35 |

Niche height 1780 - combination with pull-out trolley

3.3 Recess dimensions

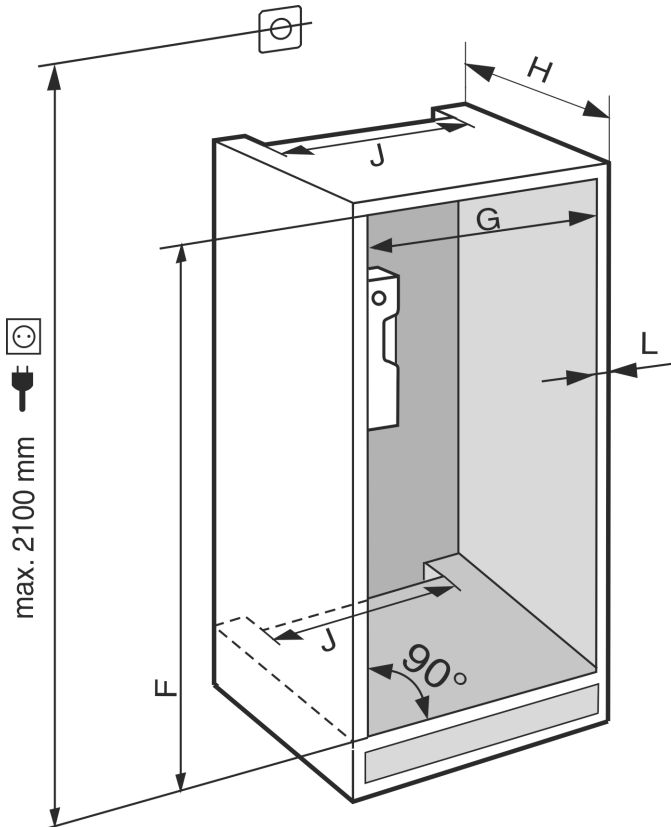

Fig. 3

| IRC(B).. 51.. | |
|---------------|---------------------------|
| F (mm) | 1772 to 1788 |
| G (mm) | 560 to 570 |
| H (mm) | min. 550, recommended 560 |
| J (mm) | min. 500 |
| L (mm) | max. 19 |

The specified energy consumption was determined with a kitchen unit depth of 560 mm. The device will work properly at a kitchen unit depth of 550 mm, but with a slightly higher energy consumption.

- ▶ Check the wall thickness of adjacent cabinets: They must have a minimum of 16 mm.
- ▶ Only fit the appliance into stable, solid kitchen units. Secure the unit against tipping.
- ▶ Align the cabinets with a spirit level and a try square. If necessary, level them by putting something underneath them.
- ▶ Make sure floor and the side panels of the cabinet are at right angles to each other.

3.3.1 Ventilation requirements

NOTICE

Covered vents!

Damage. Appliance can overheat, which can reduce the service life of various parts of the appliance and lead to operational impairments.

- ▶ Always make sure there is good ventilation.
- ▶ Always keep vents or ventilation grids in the appliance housing and in the kitchen furniture (fully integrated appliance) unobstructed.

Always follow the required ventilation gaps:

- The depth of the ventilation shaft at the back of the cabinet must be at least 38 mm.
- At least 200 cm² is required for the ventilation gap cross sections in the plinth and the housing cabinet.
- As a rule, the larger the ventilation cross-section, the more efficiently the appliance will run.

Sufficient ventilation is required for the operation of the appliance. The ventilation grids provided ensure an effective ventilation cross-section on the appliance of 200 cm². If you replace the ventilation grids with a cover plate the ventilation cross-section must be as least as large as the ventilation grid provided by the manufacturer.

3.4 Custom panel weights

NOTICE

An excessively heavy custom panel can potentially cause damage!

If the custom panel is too heavy, damage to the hinges cannot be ruled out, which may compromise the functionality of the unit.

- ▶ Before fitting the custom panel, ensure the custom panel does not exceed the permissible weight.

| Recess height (mm) | Appliance type | Maximum weight of custom panel (kg) | |
|--------------------|----------------|-------------------------------------|----------------------|
| | | Fridge section door | Freezer section door |
| 1780 | IRC.. 51.. | 18 | 12 |

Appliances with cellar compartment

3.5 Transporting the appliance

3.5.1 Transporting the appliance for initial use

Ensure that the following requirements are met:

- The appliance is packaged.
- The appliance is upright.
- ▶ Transport the appliance with the help of two people.
- ▶ Unpacking the appliance. (see 3.6 Unpacking the appliance)

3.5.2 Transporting the appliance after initial use

Observe the following instructions if you wish to transport or move the appliance again after initial use.

Ensure that the following requirements are met:

- The appliance is emptied.
- The appliance is upright.
- Appliance with door(s): Door is secured against accidental opening.
- Appliance with telescopic unit: The telescopic unit is secured against accidental opening.
- Appliance is removed.
- ▶ Transport the appliance with the help of two people.

3.6 Unpacking the appliance











Before you connect the appliance, report any damage immediately to the delivery company.









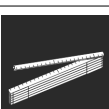

- ▶ Check the appliance and the packaging for damage during transport. Contact the supplier immediately if you suspect any level of damage.

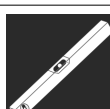
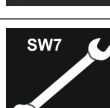
Setting up and connecting

- ▶ Remove all materials from the back or the side walls of the appliance that may prevent proper installation or ventilation.
- ▶ Remove all protective films from the appliance. Do not use sharp or pointed objects for this.

3.7 Explanation of symbols used

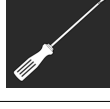
| | |
|-------------------------------------------------------------------------------------|------------------------------------------------------------------------------------------------------------------------|
|  | There is a danger of injury during this step! Observe the safety instructions! |
|  | The instruction is valid for several models. Only perform this step if it applies to your appliance. |
|  | For installation, please refer to the detailed description in the text section of the instructions. |
|  | Section is valid for either a single-door appliance or a double-door appliance. |
|  | Choose between the following options: Appliance with door hinge on the right or appliance with door hinge on the left. |
|  | Installation step required for IceMaker and/or InfinitySpring. |
|  | Only loosen or lightly tighten the screws. |
|  | firmly tighten the screws. |
|  | Check whether the following step is necessary for your model. |
|  | Check that the components used are correctly installed/fitted. |
|  | Measure the specified dimension and correct if necessary. |
|  | Tool for installation: Metre stick |

| | | |
|-------------------------------------------------------------------------------------|------------------------------------------------------------------------------------|------------------------------------------------------------------------------------------------------------------------------|
|  |  | Tool for installation: Cordless screwdriver and use A lengthwise bit insert is recommended for good access to the screws. |
|  | | Tool for installation: Spirit level |
|  | | Tool for installation: Open-end wrench with AF 7 and AF 10 |
|  | | Two people are required for this step. |
|  |  | The step takes place at the marked location on the appliance. |
|  | | Aid for installation: String |
|  | | Aid for installation: Protractor |
|  | | Aid for installation: Screwdriver |
|  | | Aid for installation: Scissors |
|  | | Aid for installation: Marking pen, wipeable |
|  | | Included: Remove components |
|  | | Dispose of components that are no longer required in accordance with local regulations. |

3.8 Reversing the door

Tool



Fig. 4

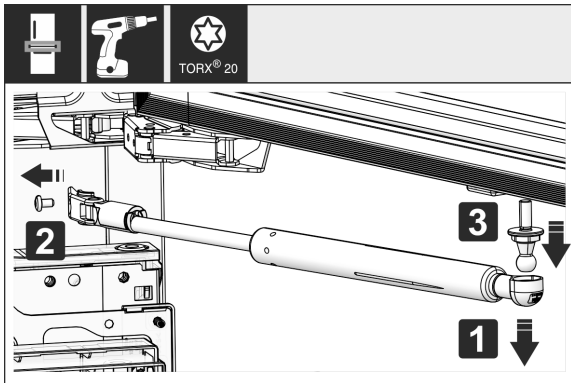

Fig. 5

- ▶ Removing the soft stop damper: Remove the soft stop damper from the ball stud (1). Unscrew the retainer (2). Remove the ball stud with a screwdriver (3).

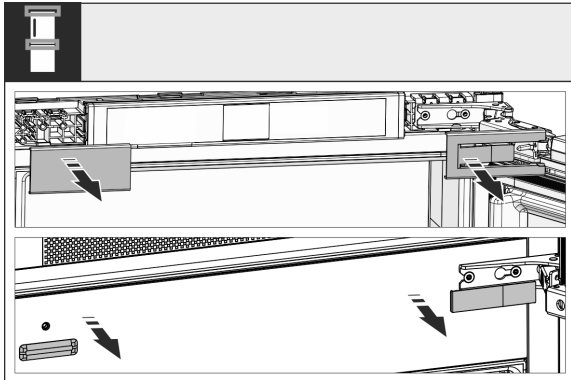

Fig. 6

- ▶ Remove covers.

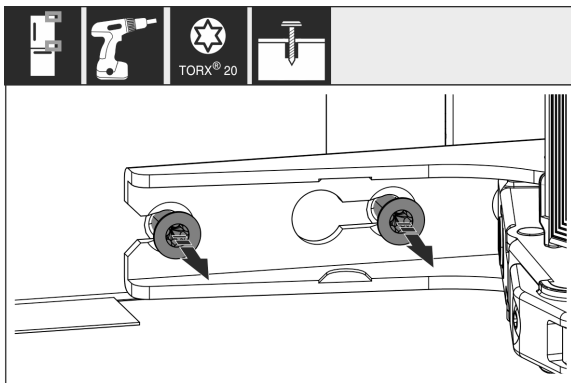

Fig. 7

- ▶ Loosen the screws on **all** hinges but do not remove them.

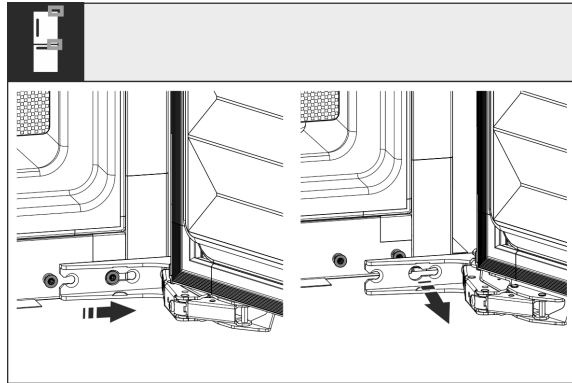

Fig. 8

- ▶ Removing the door: Push the door forward and then out, unhook it and put it to one side.

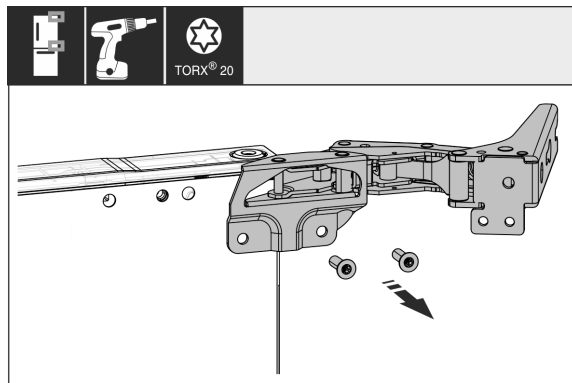

Fig. 9

- ▶ Unscrew all hinges and set aside with the screws.

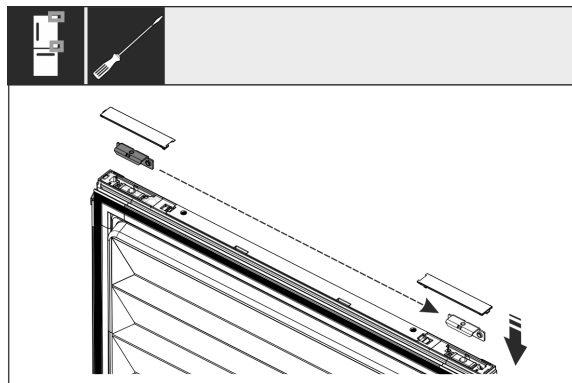

Fig. 10

- ▶ Loosen and shift the bracket at the top and bottom of the door. The bracket must be shifted so you can screw on the hinges.

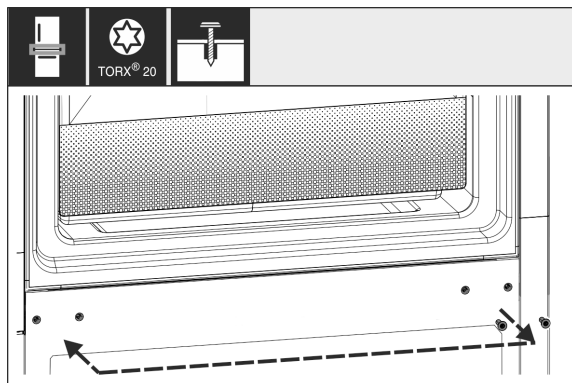

Fig. 11

Setting up and connecting

- Schrauben für die Scharnierbefestigung umsetzen. Nach dem Umsetzen nicht festschrauben, die Scharniere müssen später eingehängt werden.

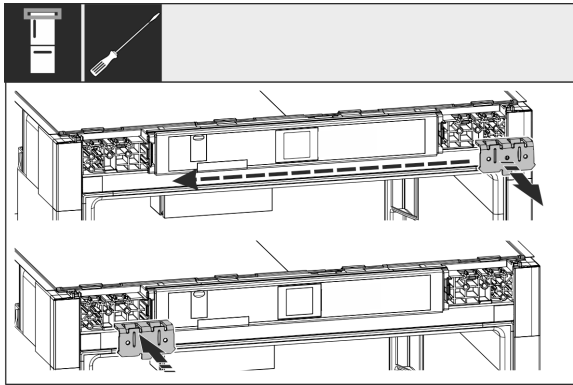

Fig. 12

- Move the fixing bracket to the opposite side.

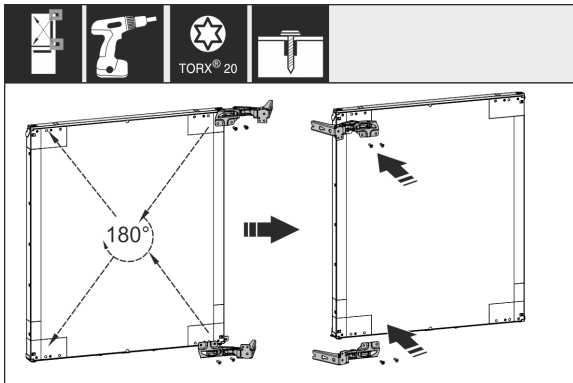

Fig. 13

- Turn all hinges 180° to the opposite side and screw firmly.

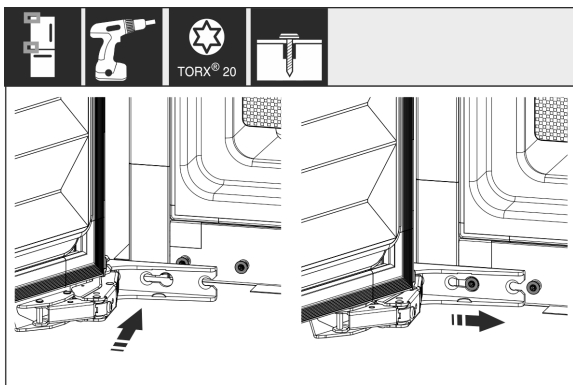

Fig. 14

- Refitting the door: Hang the door with its hinges and tighten the screws.

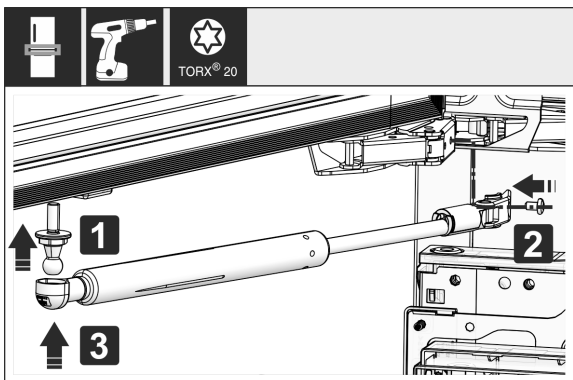

Fig. 15

- Refitting the closing dampers: Screw in the ball studs (1), tighten the bracket (2) and hang the closing dampers in the ball studs.
- Check all screws and retighten if necessary.

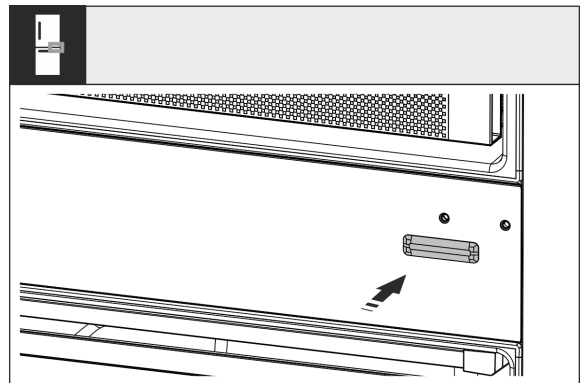

Fig. 16

- Fit the bottom left cover again. Only fit the other covers again after installing the appliance into the cabinet again.

3.9 Setting up the appliance



CAUTION

Risk of injury due to heavy appliance!

- Have two people transport the appliance to its installation site.



WARNING

Danger of injury and damage due to the appliance being unstable!

The appliance can topple over.

- Secure the appliance as described in the instructions.



WARNING

Fire hazard and danger of damage!

- Do not place appliances emitting heat e.g. microwaves, toasters etc. on the appliance!

If possible, have the appliance installed in the kitchen unit by a professional.

Do not install the appliance on your own.

3.9.1 After installation

- Remove all transport safety components.
- Pull off the transport lock on the appliance door.*

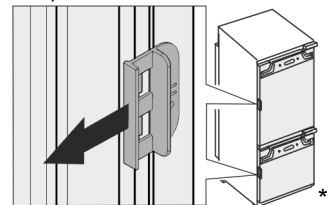

- Clean the appliance (see User Guide, Cleaning the appliance).

3.10 Installing multiple appliances

The appliances have been developed for different installation methods. If you wish to install several appliances next to each other or on top of each other, ensure that the following requirements are met:

- ❑ Only install appliances next to or on top of each other if they have been developed for this.
- ❑ Observe notices and the following table.

NOTICE

Risk of damage due to condensate!

- ▶ Do not place the appliance directly next to another cooling/refrigeration unit.

NOTICE

Risk of damage due to condensation!

- ▶ Do not place the appliance directly on top of another cooling/refrigeration unit.

| Model | Installation method |
|---------------------------------------------------------------------------------------------------------------------------------------------------------------------------|----------------------|
| All models | Standalone |
| Models with a model designation starting with S... | Side-by-Side (SBS) |
| Models up to a maximum niche height of 880 mm and with a heated ceiling can be installed "on top of each other". Top appliance: up to a maximum niche height of 140 mm | On top of each other |

Models and their installation method

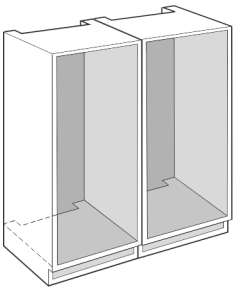

Fig. 17

Install each appliance into a separate unit niche.

3.11 Disposing of packaging



WARNING

Danger of suffocation due to packing material and plastic film!

- ▶ Do not allow children to play with packing material.

The packaging is made of recyclable materials:

- corrugated board/cardboard
 - expanded polystyrene parts
 - polythene bags and sheets
 - polypropylene straps
 - nailed wooden frame with polyethylene panel*
- ▶ Take the packaging material to an official collecting point.

3.12 Installing the appliance in the recess

Tool

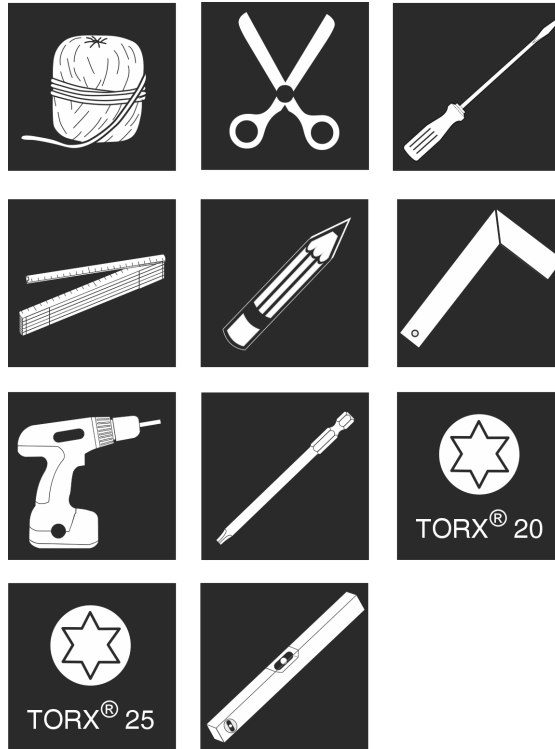

Fig. 18

Supplied assembly parts

Setting up and connecting

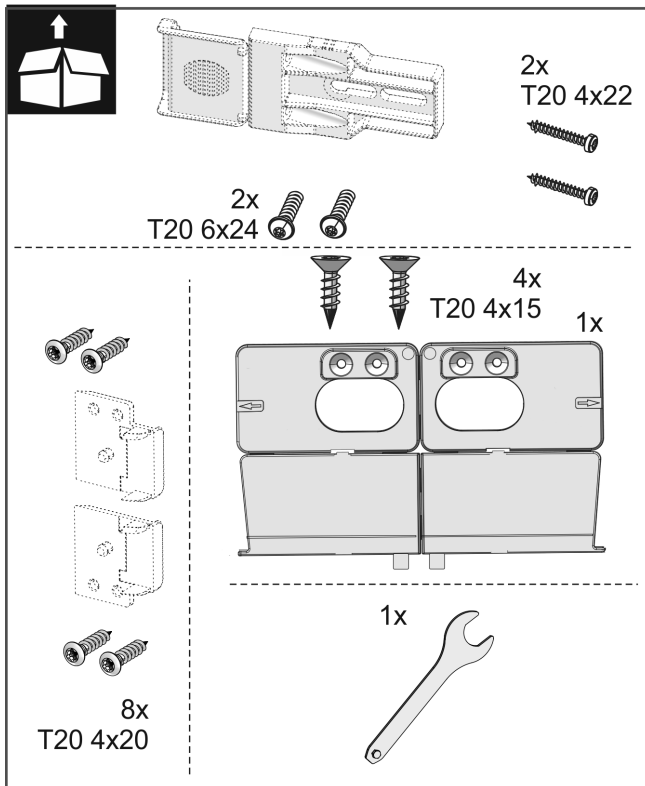
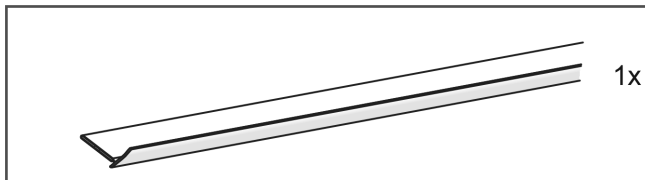
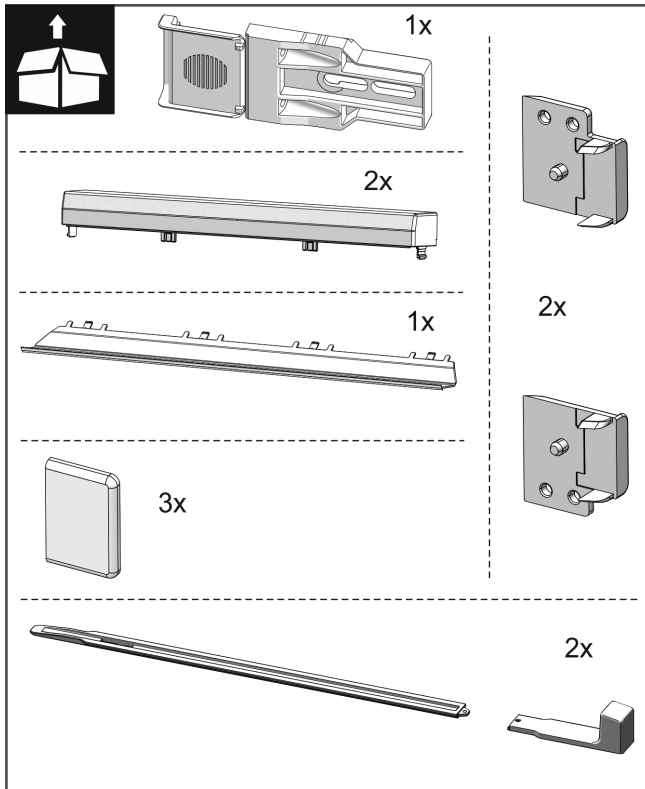

Fig. 19

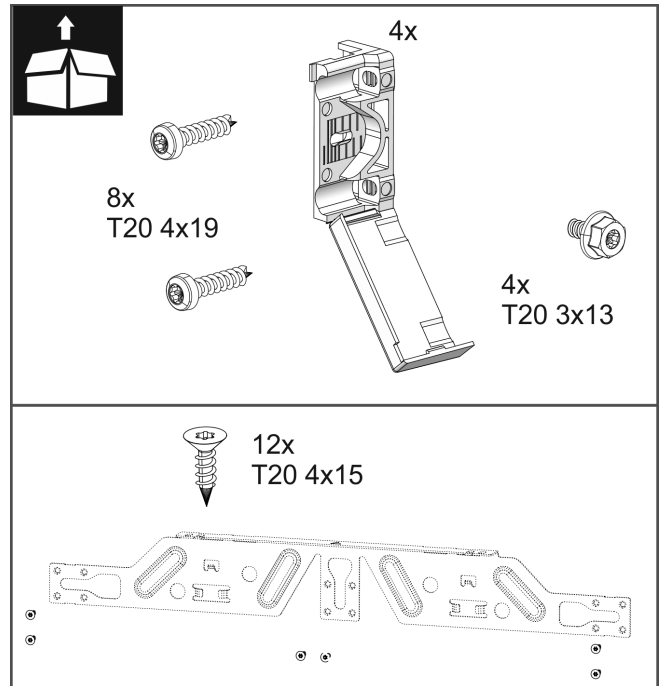

Fig. 20

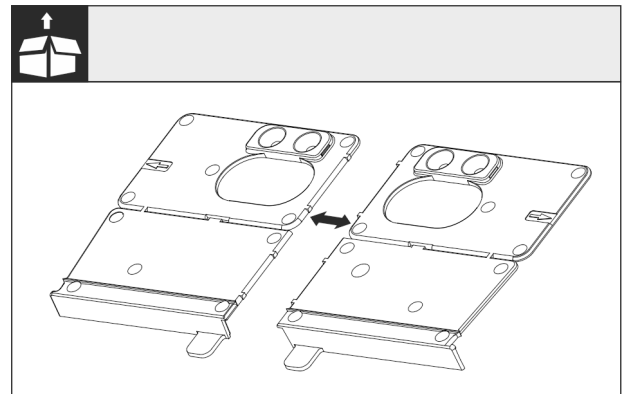

Fig. 21

► Separate the mounting bracket at the perforation.

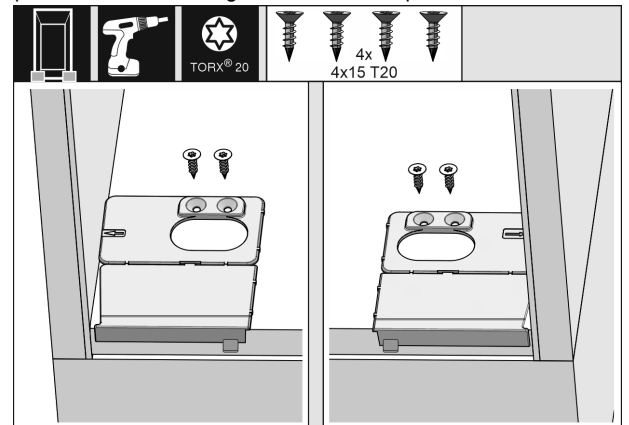

Fig. 22

NOTICE

Correct installation depth of the appliance.

► Using the mounting bracket ensures the correct installation depth of the appliance.

► Screw the mounting brackets on the left and right of the recess floor, flush to the side wall.

Setting up and connecting

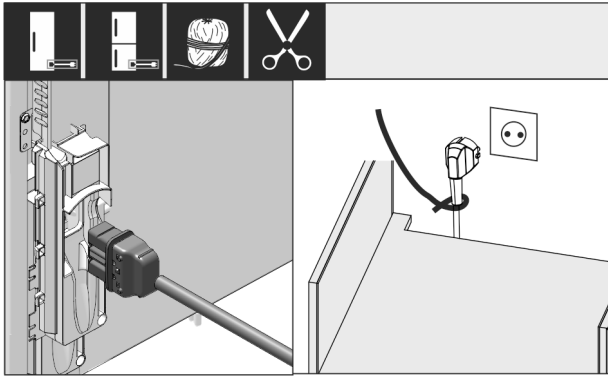

Fig. 23

- ▶ Remove the mains cable from the package.
- ▶ Plug the mains cable's IEC socket completely into the appliance plug on the back of the appliance. Ensure that the IEC socket is tight.
- ▶ Use a cord to lay the mains plug to a freely accessible socket.

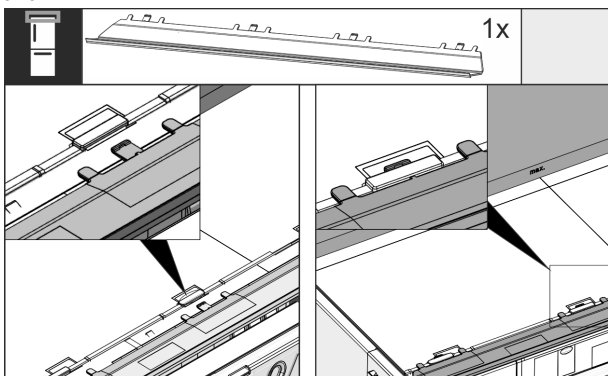

Fig. 24

- ▶ Insert the adapter panel on the top of the appliance. The panel can be moved to both sides.

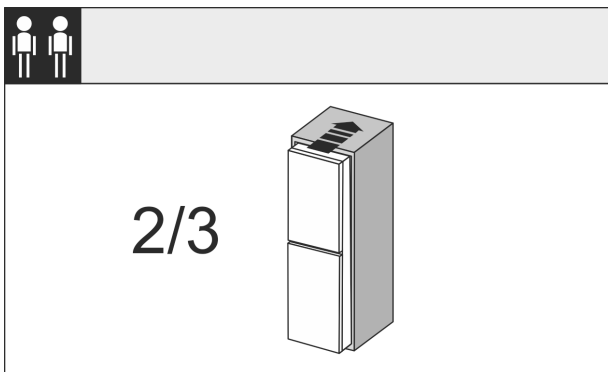

Fig. 25

- ▶ Insert the appliance 2/3 of the way into the recess.

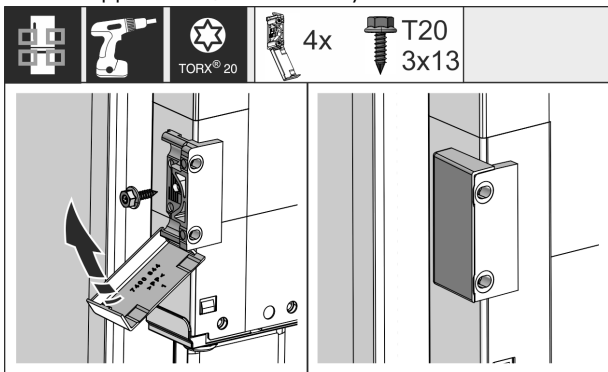

Fig. 26

- ▶ Assemble the mounting bracket. Attach the mounting brackets to align with the cabinet door handles. After assembly, fold the covers onto the bracket.

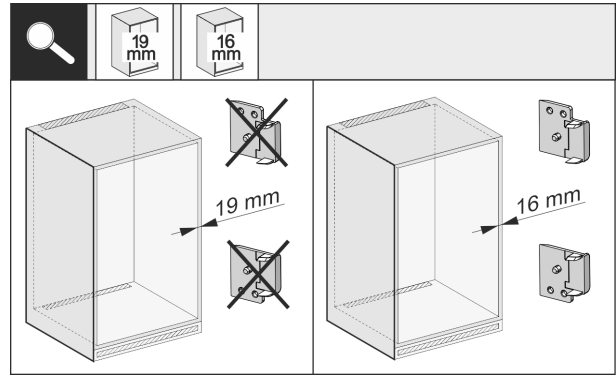

Fig. 27

- ▶ Check whether the cabinet side wall is 16mm or 19mm thick.

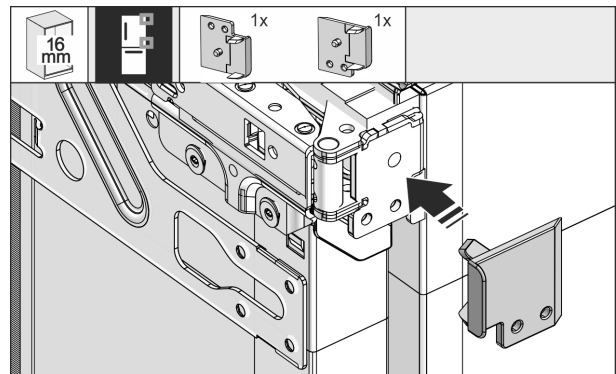

Fig. 28

- ▶ For 16-mm thick cabinet walls: Spacer on all hinges. For 19-mm thick cabinet walls, no spacer is required.

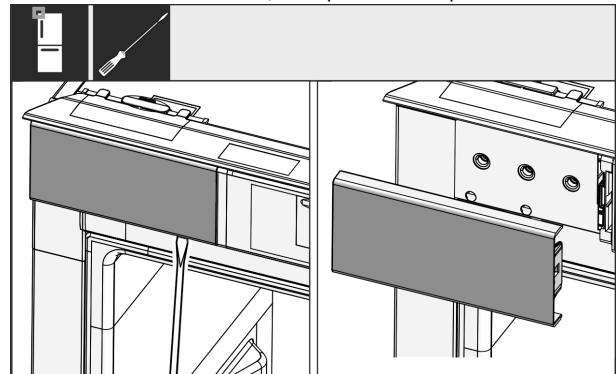

Fig. 29

- ▶ Use a screwdriver to loosen the cover at the top left and then remove it.

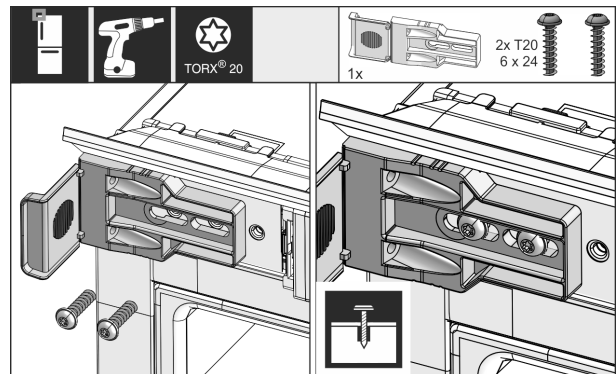

Fig. 30

- ▶ Loosely tighten the mounting bracket screw. The bracket should still be easy to move.

Setting up and connecting

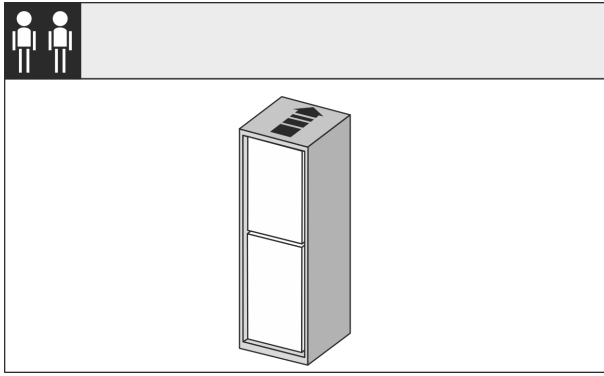

Fig. 31

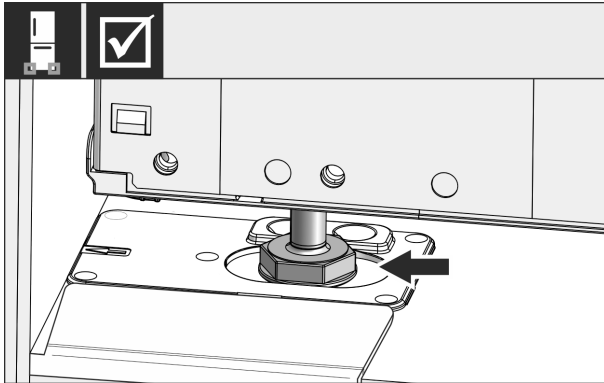

Fig. 32

! WARNING

Risk of fire due to short circuit!

- ▶ When you push the appliance into the niche: do not kink, jam or damage the mains cable.
- ▶ The appliance must not be operated with a defective mains cable.

- ▶ Insert the appliance all the way into the recess. The adjusting feet must sit on both sides in the recesses of the mounting bracket base.

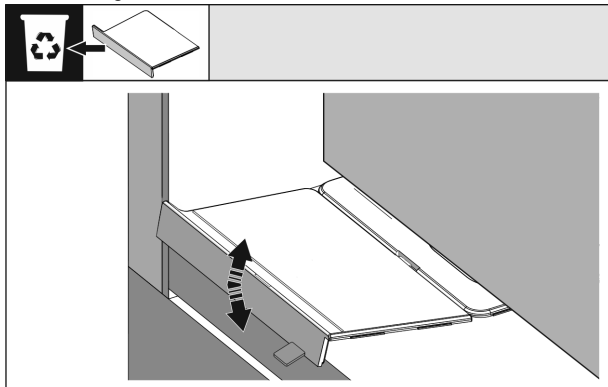

Fig. 33

- ▶ Remove the front stopper of the mounting bracket base. Loosen the stopper by moving it and, if necessary, pull it off with the help of pliers.

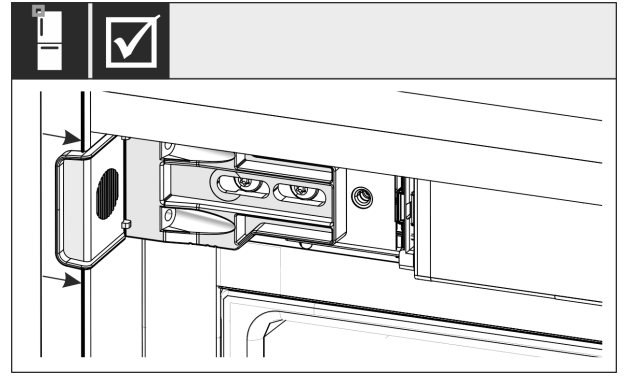

Fig. 34

- ▶ Check that the appliance is flush against the cabinet recess. The mounting bracket must be attached to the side wall of the cabinet recess.

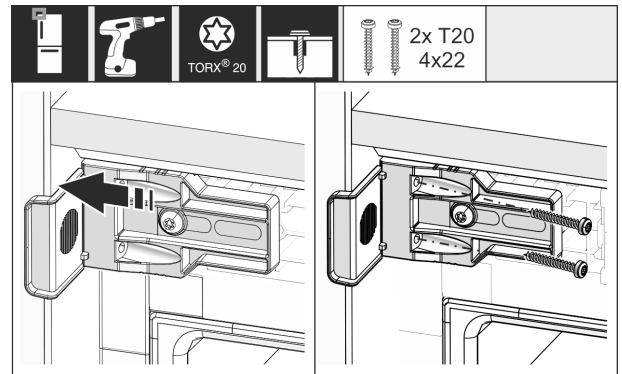

Fig. 35

- ▶ Move the bracket so it sits flush on the side wall of the cabinet recess. Now tighten all the screws firmly.

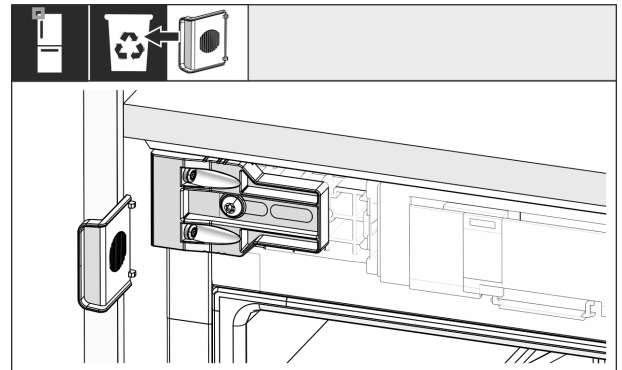

Fig. 36

- ▶ Remove the stop from the bracket on the handle side and dispose of it.

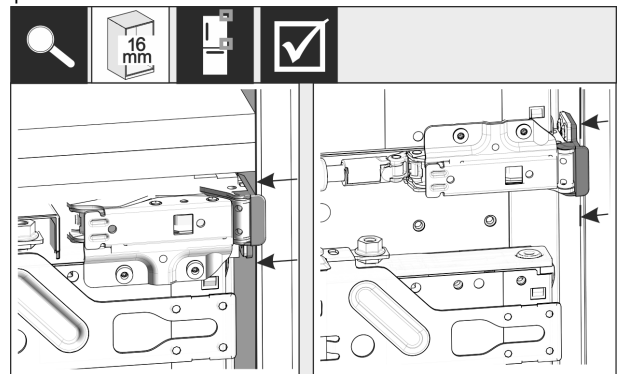

Fig. 37

- ▶ With 16 mm-thick cabinet side walls, the hinge-side spacers must strike at the side wall of the recess.

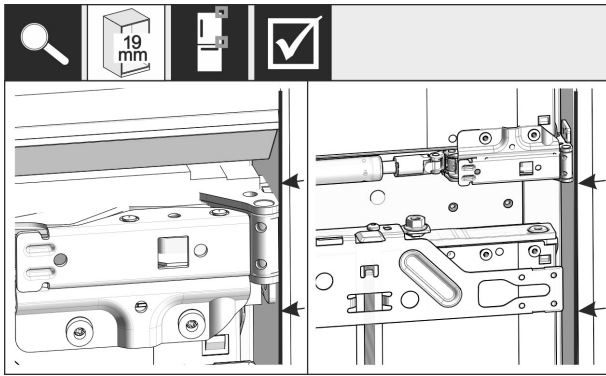

Fig. 38

- ▶ With 19 mm thick cabinet side panels, align the front edges of the hinges so that they are flush with the front of the cabinet side panel.

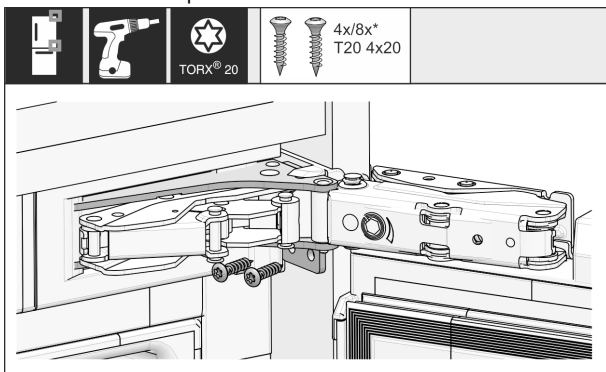

Fig. 39

- ▶ Secure the appliance on the hinge side

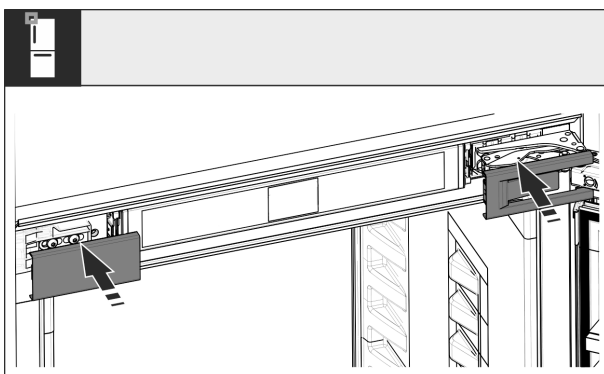

Fig. 40

- ▶ Put covers into position.

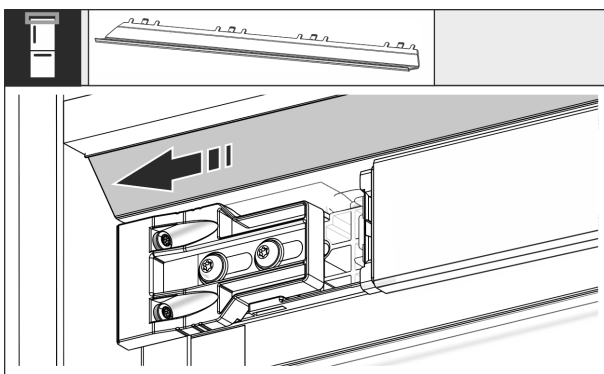

Fig. 41

- ▶ Slide the panel so that it sits flush on the side of the cabinet wall.

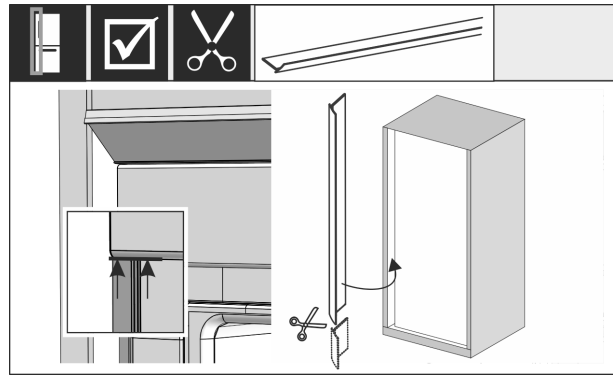

Fig. 42

- ▶ The tread is magnetic. Place the tread below the top cover and press. If necessary, shorten the tread to the required length with a sharp pair of scissors.

From a niche height of 1400 mm, install levelling rails:



Fig. 43

You must install levelling rails under the appliance from a niche height of 1400 mm. The levelling rails **reduce the noise level**. Two levelling rails and an installation handle are enclosed as standard from a niche height of 1400 mm.

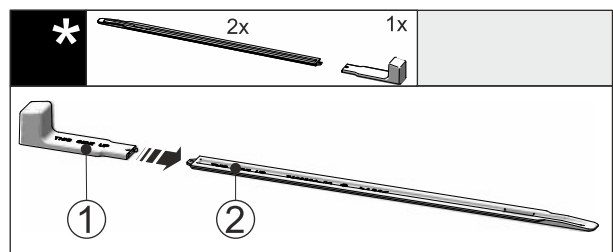

Fig. 44

- ▶ Attach the installation handle Fig. 44 (1) to the levelling rail Fig. 44 (2).

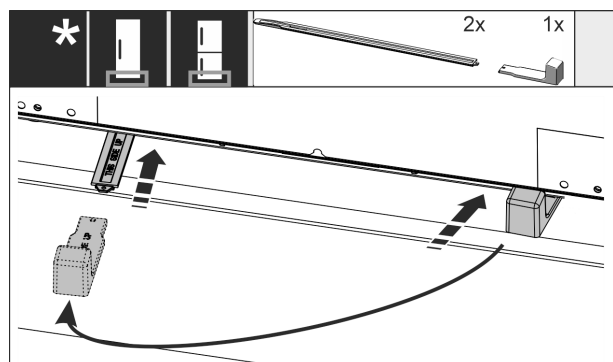

Fig. 45

- ▶ Push the levelling rail into the guide under the appliance base until it reaches the stop.
- ▶ Remove the installation handle and attach it to the second levelling rail.
- ▶ Proceed in the same way for the second levelling rail.

Setting up and connecting

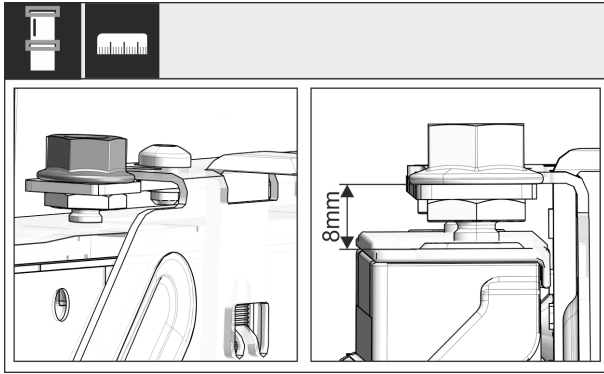

Fig. 46

- ▶ Close the door and check the preset 8 mm from the upper edge of the appliance door to the crosspiece support

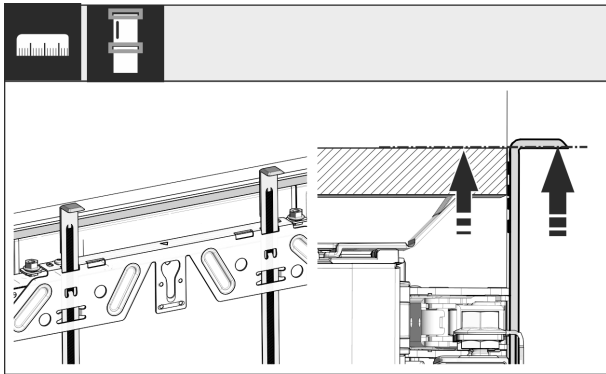

Fig. 47

- ▶ Push up mounting aids to the cabinet door height of the adjacent cabinet fronts. Lower stop edge of the assembly aid = upper edge of the door to be assembled.

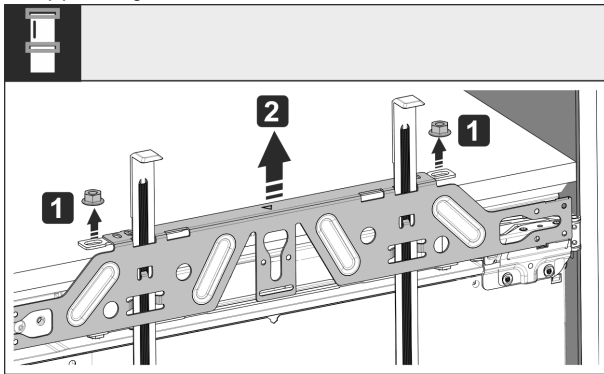

Fig. 48

- ▶ Loosen the counter nut and remove the crosspiece.

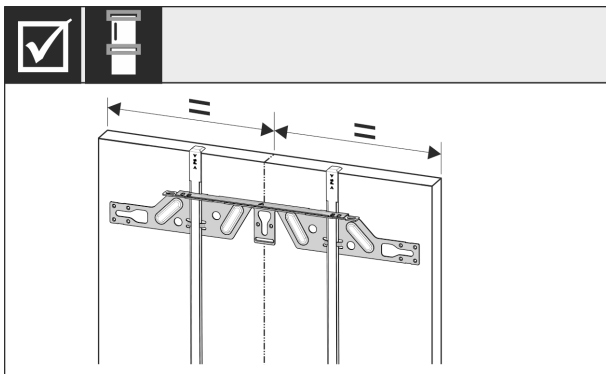

Fig. 49

- ▶ Hang the crosspiece on the inside of the unit door and make sure it is central.

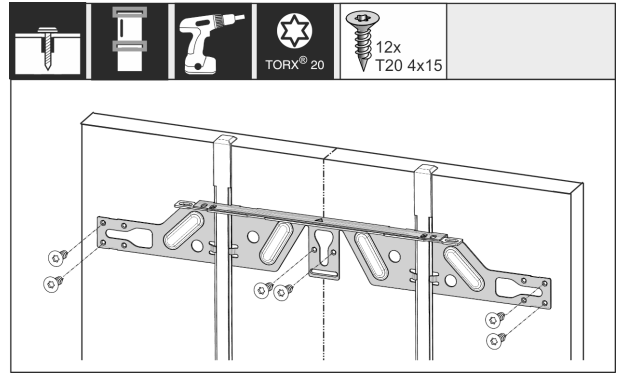

Fig. 50

- ▶ With chipboard doors fit the crosspiece with at least 6 screws and at least 4 screws for the frame and panel doors. In the case of frame and panel doors, mount the screws as far out as possible.

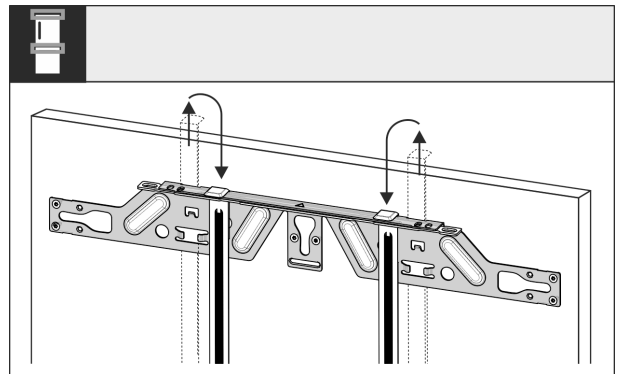

Fig. 51

- ▶ Remove the fitting aids, turn round and insert into the adjacent opening.

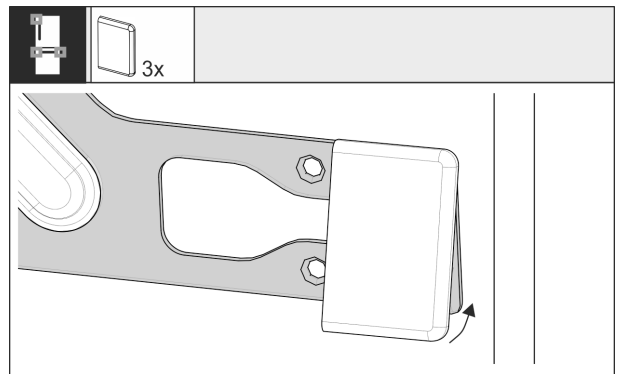

Fig. 52

- ▶ With the top door, clip the cover onto the mounting crosspiece. With the pull-out trolley, clip the covers on both sides of the crosspiece

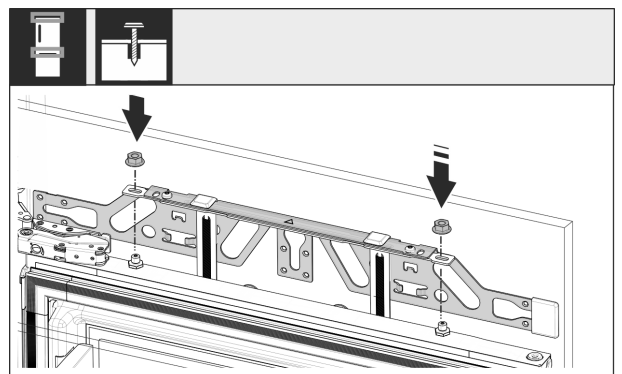

Fig. 53

- ▶ Attach the cabinet door and loosely screw the lock nuts onto the adjusting bolts.

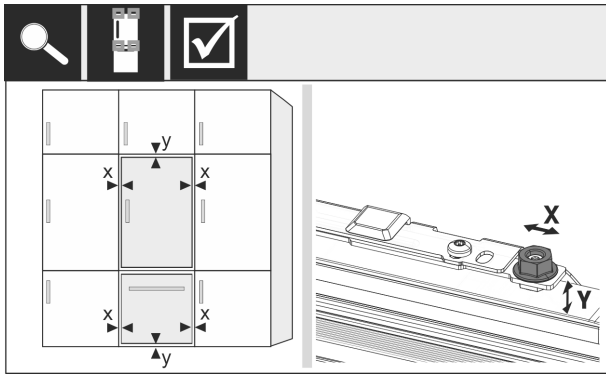

Fig. 54

- ▶ Align the unit door in the X and Y direction using the adjusting bolts.

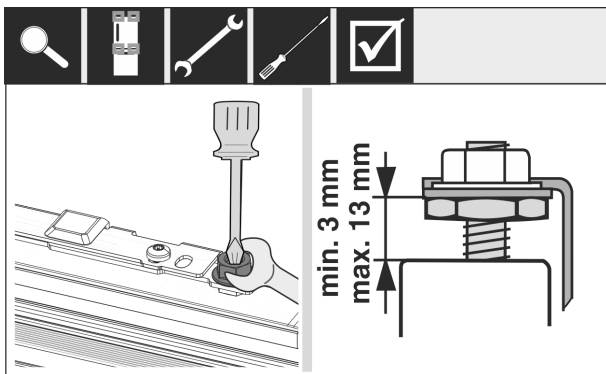

Fig. 55

- ▶ Tighten the counter nuts and check the setting height.

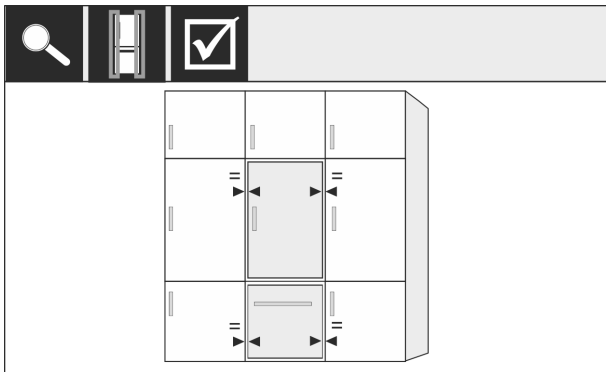

Fig. 56

- ▶ Check the gap between the door and the surrounding unit doors.

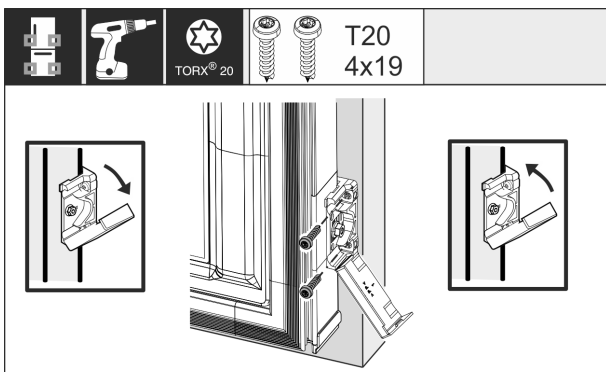

Fig. 57

- ▶ Open the cover again to assemble the mounting bracket on the unit door. Align the front edge of the mounting bracket parallel to the unit door edge and screw the bracket down tightly. Fold up the cover again.

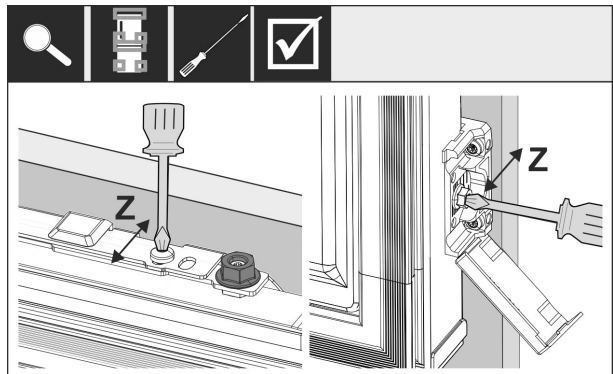

Fig. 58

- ▶ Align the unit door in the Z direction: undo the adjusting screw on the crosspiece and the screw on the mounting bracket then move the door.

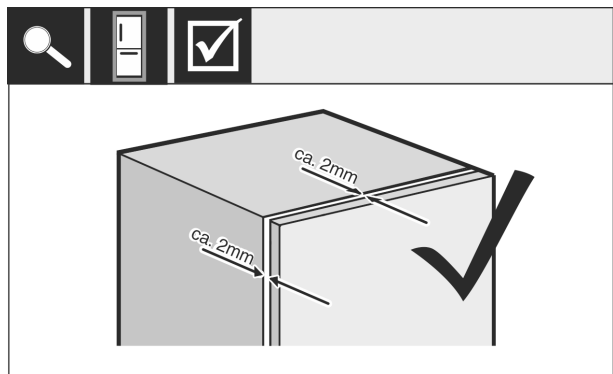

Fig. 59

- ▶ Check the distance between the unit door and the unit body. Check all screws and retighten if necessary.

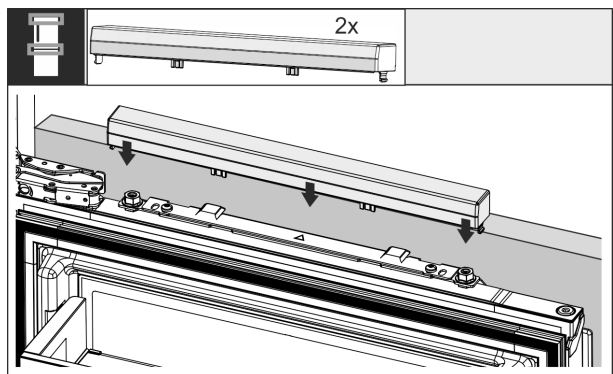

Fig. 60

- ▶ Clip the top cover on.

Check the following points to make sure the appliance is installed correctly. Otherwise, icing up, the formation of condensate and malfunctions may occur:

- ▶ The door must close properly.
- ▶ The unit door must not touch the body of the unit.

3.12 Cabinet fronts

3.13 Dimensions

Depending on your model, you will need one or two cabinet doors. The size of the cabinet door(s) depends on the overall recess size and cabinet unit thickness.

Setting up and connecting

Note

Observe the corresponding appliance and niche dimensions, and installation sketches.

General requirements:

- Please note our appliance-specific recommendations on size and weight for fixed door installation. (see 3.4 Custom panel weights)
- The body of the unit should be at least 16 mm thick but not more than 19 mm.
- When mounting a 2-door cabinet door, observe the recommended clearances.

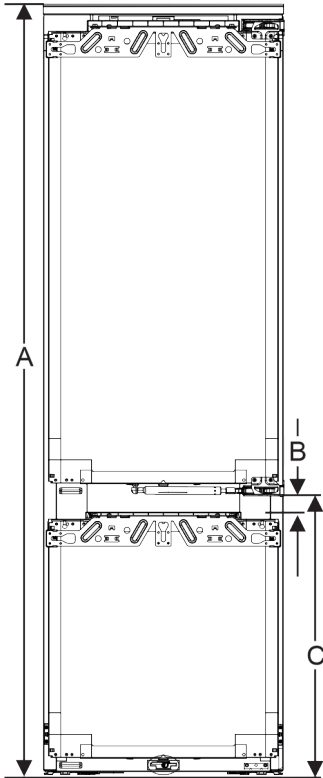

Fig. 61 Clearance, larder compartment

| | |
|---------------------------------------|----------|
| Recess height 178 | |
| Appliance height (A) (mm) | 1770 |
| Distance (B) (mm) | 34 |
| Clearance (C) cellar compartment (mm) | 612 + 34 |

Other cabinet door above, below or next to it:

- The vertical gap between custom panels must be 4 mm.
- The horizontal gap between custom panels must be 4 mm. Check the risk of them clashing here. (see 3.15 Setting the clearance to avoid collision)

Weight and hinges:

- With heavy furniture fronts, the stress on the hinge is very high. The hinge may be damaged. Please note the maximum weight specification for your appliance in the chapter Furniture front weights (see 3.4 Custom panel weights).

- If the cabinet front exceeds the maximum permitted weight, an appliance with door-tracking device can help by loading the weight over several concealed hinges on the cabinet.
- If you use long unit fronts that protrude far above the appliances, we recommend an additional door hinge (e.g. Kamat), which must have the same pivot point as the fixed door hinge used with your appliance. By using another hinge (Kamat), the weight is shared over several points. The use of a milled compensating fastening is recommended for high unit fronts to counteract warping (convex/concave).

3.14 Mounting the cabinet front(s)

When installing, note:

- Cabinet front must be installed symmetrically to the refrigerator door.
- Adjoining cabinet front is exactly level.
- Adjoining cabinet front has the same edge radius as the front of the appliance.
- Cabinet front is flat and tension-free.
- The front panel has a minimum depth setting of approx. 2 mm to the body.
- ▶ Install the appliance in the recess.
- ▶ Fasten the front panel to the appliance door.
- ▶ Check that the front panel can close unobstructed. (see 3.15 Setting the clearance to avoid collision)

3.15 Setting the clearance to avoid collision

After installing the cabinet front(s), check that the cabinet fronts do not collide.

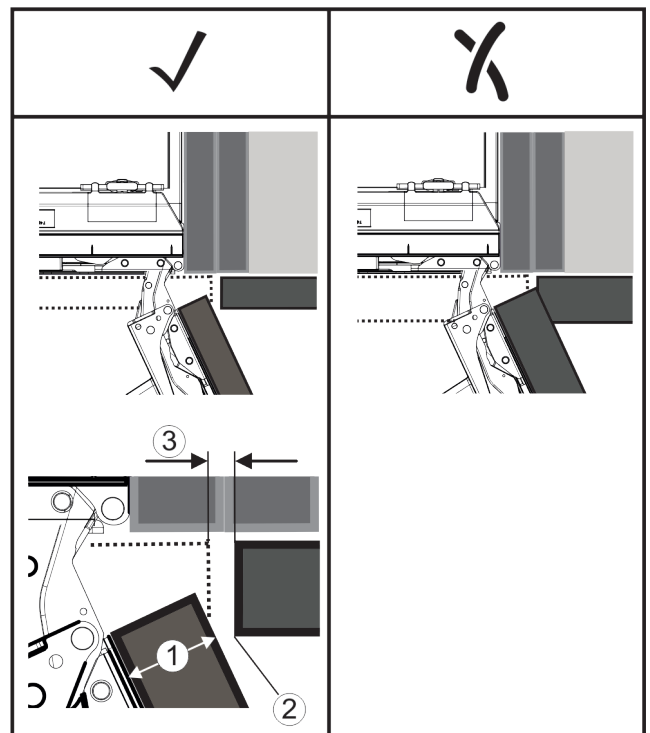

Fig. 62

(1) Front thickness (FD)
(2) Edge radius (R)

(3) Clearance (S)

Functionality of the Touch display

| FD(1) (mm) | R (2) = 0 mm | | R = 1,2 mm | | R = 2 mm | | R = 3 mm | |
|------------|------------------|------------------|------------------|------------------|------------------|------------------|------------------|------------------|
| | G _{min} | G _{max} | G _{min} | G _{max} | G _{min} | G _{max} | G _{min} | G _{max} |
| 16 | 0,3 | 0,9 | 0,1 | 0,4 | 0,1 | 0,2 | 0,1 | 0,2 |
| 19 | 0,7 | 2,4 | 0,3 | 1,9 | 0,5 | 2,3 | 0,1 | 0,8 |
| 20 | 2 | 4,3 | 1,5 | 3,6 | 1 | 3,1 | 0,6 | 2,7 |
| 22 | 3,5 | 6,3 | 3 | 5,6 | 2,6 | 5,3 | 2,1 | 4,6 |
| 24 | 5,5 | 8,3 | 5 | 7,8 | 4,5 | 7,4 | 4 | 6,9 |
| 26 | 7,6 | 10,7 | 7 | 10,3 | 6,6 | 9,9 | 6,2 | 9,4 |

Fig. 63 Table of clearance limits*

G_{min} = min. clearance in mm*

G_{max} = max. clearance in mm*

Note

When making adjustments, always make sure that the cabinet front suits the general appearance.

Check the collision factors and adjust them accordingly:

- ▶ Determine the front thickness and edge radius.
- ▶ Refer to the table for the min./max. clearance dimensions.
- ▶ Check the clearance size against the table.
- ▶ Do one of the following depending on the measured clearance size.

| Clearance | Description |
|-------------------------------|-----------------------------------------------------------------------------------------------------------------|
| $S > G_{max}$ | If the clearance size is greater than the two limits, you do not need to make any adjustments. |
| $S < G_{min}$ | If the clearance size is below the limits, you must increase it. Another option is to increase the edge radius. |
| $G_{min} \leq S \leq G_{max}$ | If the clearance is between the two limits, you have to be careful. This will quickly lead to collisions. |

3.16 Connecting the appliance to the power supply



WARNING

Danger of electric shock and injury due to damaged appliance or damaged mains cable!
 Danger of cuts and fatal injuries. If the appliance or the mains cable is damaged during transport, you may be electrocuted. You could also cut yourself on damaged parts of the appliance housing.

- ▶ Check the appliance and the mains cable for damage after transport.
- ▶ Never put the appliance into operation if the appliance or the mains cable are damaged.
- ▶ Contact Customer Service.

You can connect your appliance to the mains using the power cable supplied separately. The mains power cable has an appliance coupler at one end and a mains plug at the other end.

Make sure that the following requirements are fulfilled:

- The appliance and power cable are undamaged.
- The appliance is installed in accordance with the regulations. (see 3.12 Installing the appliance in the recess)
- Requirements for the electrical connection are met.
- Dimensions for connection in accordance with regulations are known and observed.
- Mains voltage and frequency correspond to the specifications on the type plate.
- The socket is earthed according to the regulations and fused.

- The fuse tripping current is between 10 A and 16 A.
- The socket is easily accessible and is not behind the appliance. (see 3.3 Recess dimensions)

NOTICE

Danger of damage to incorrect operation!
 Damage to the electrical components of the appliance.

- ▶ Only use the supplied mains cable.



WARNING

Danger of fire due to incorrect connection!
 Burns.

Damage to the appliance.

- ▶ Do not use an extension cable.
- ▶ Do not use distributor blocks.

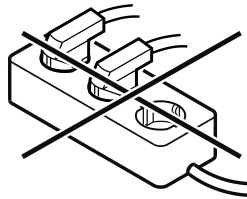

NOTICE

Danger of damage to incorrect connection!
 Damage to the appliance.

- ▶ Do not connect the appliance to a stand-alone inverter, e.g. solar power systems and petrol generators.

- ▶ Connect the mains cable plug to the power supply. Ensure that the plug is tightly in the socket.
- ▶ The Liebherr logo appears in the display.
- ▶ The display switches to the standby symbol.
- ▶ If no action occurs within 60 seconds: The standby symbol fades or disappears.
- ▶ The appliance is connected. For information regarding first use, see the following section or the operating instructions.

4 Functionality of the Touch display







You operate your appliance using the Touch display. You select appliance functions in the Touch display (hereafter referred to as display) by tapping them. If you do not perform any action on the display for 10 seconds, the display either jumps back to the higher-level menu or directly to the status display.

4.1 Navigation and symbol explanation

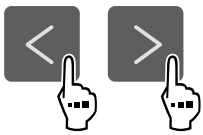
In the illustrations, different symbols are used to navigate the display. The following table describes these symbols.

| Symbol | Description |
|--------|--------------------------------------------------------------------------------------|
| | Press the Next navigation arrow: Navigates to the next option in the menu. |
| | Press the Back navigation arrow: Jumps back one option in the menu. |

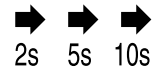
Functionality of the Touch display

| Symbol | Description |
|-------------------------------------------------------------------------------------|---------------------------------------------------------------------------------------------------------------------------------------------------------------------------------------------------------------------|
|  | Press the navigation arrow several times in succession: Navigates in the menu to the desired function. |
|  | Press the Confirm symbol: Activates/deactivates function. Opens submenu. |
|  | Press the Confirm symbol together with the back icon: Jumps back one menu level. |
|  | Arrow with clock: It takes more than 10 seconds for the following message to appear in the display. |
|  | Arrow with a time indication: It takes the specified amount of time until the following message appears in the display. |
|  | “Open Settings menu” symbol: Navigates to the Settings menu and opens the settings menu. If necessary: Navigate to the desired function in the Settings menu. (see 4.2.1 Opening the Settings menu) |
|  | “Open Advanced menu” symbol: Navigates to the Advanced menu and opens the advanced menu. If necessary: Navigate to the desired function in the Advanced menu. (see 4.2.2 Opening the Advanced menu) |
| No action for 10 seconds | If you do not perform any action on the display for 10 seconds, the display either jumps back to the higher-level menu or directly to the status display. |
| Close the door and open it again. | If you close the door and immediately open it again, the display jumps directly back to the status display. |

Note: Illustrations of the display are shown in the English version.

4.2 Menus

The appliance functions can be found in various menus.

| Menu | Description |
|-----------|---------------------------------------------------------------------------------------------------------------------------------------------------------------------------------------------------|
| Main menu | When you switch the appliance on, you are automatically in the main menu. From here you can navigate to the most important appliance functions, to the Settings menu and to the Advanced menu. |

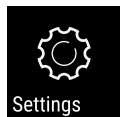
| Menu | Description |
|----------------------------------------------------------------------------------------------------|------------------------------------------------------------------------------------------------------------------------------------------------------------------------------------------------------------|
|  Settings menu | The Settings menu contains additional appliance functions for setting up your appliance. (see 4.2.1 Opening the Settings menu) |
| Advanced menu | The advanced menu contains special appliance functions for setting up your appliance. Access to the Advanced menu is protected by the numerical code 151 . (see 4.2.2 Opening the Advanced menu) |

4.2.1 Opening the Settings menu

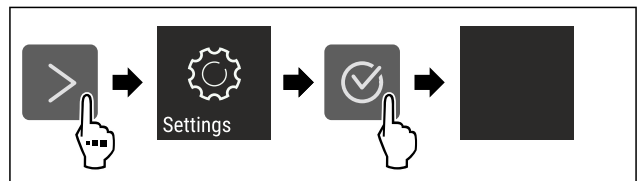

Fig. 64 Example illustration

- ▶ Carry out action steps according to the illustration.
- ▷ Settings menu is open.
- ▶ If necessary: Navigate to the desired function.

4.2.2 Opening the Advanced menu



Fig. 65

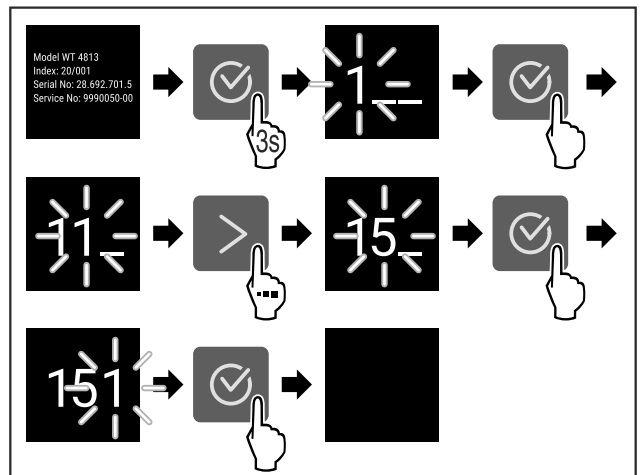

Fig. 66 Example illustration, access with numerical code **151**

- ▶ Carry out action steps according to the illustration.
- ▷ The expanded menu is open.
- ▶ If necessary: Navigate to the desired function.

4.3 Sleep mode

If you do not touch the display for 1 minute, the display switches to sleep mode. In sleep mode, the display brightness is dimmed.

4.3.1 Ending sleep mode

- ▶ Press any navigation key.
- ▷ Sleep mode is ended.

5 Putting into operation

5.1 Switching on appliance (first use)

Make sure that the following requirements are fulfilled:

- ❑ The appliance is properly installed and connected according to the installation instructions.
- ❑ All adhesive strips, adhesive and protective films and transport locks are removed from inside and on the appliance.
- ❑ All marketing leaflets are removed from the drawers.
- ❑ You are familiar with the functionality of the Touch display. (see 4 Functionality of the Touch display)

Switch on the appliance using the Touch display:

- ▶ If the display is in sleep mode: Press the confirmation symbol.
- ▶ Carry out action steps according to the illustration.

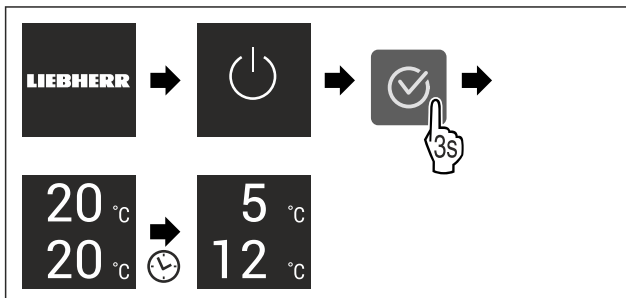

Fig. 67 Example illustration

- ▶ Status display appears.
- ▶ The appliance cools to the temperature set at the factory.
- ▶ The appliance starts in demo mode (status display with DEMO appears): If the appliance starts in demo mode, you can deactivate demo mode within the next 5 minutes. (see Demo mode)

More information:

- Start the SmartDevice for the first time. (see 2.3 Smart-Device) and (see WiFi)

Note

The manufacturer recommends:

- ▶ Stock with food: Wait for around 6 hours until the set temperature is reached.
- ▶ **Store frozen foods** at -18 °C or colder.
- ▶ Observe the notes on storing food. (see 6.1 Information regarding storage)

Note

Accessories can be purchased from the Liebherr-Hausgeräte store at home.liebherr.com/shop/de/deu/zubehor.html.

6 Storage

6.1 Information regarding storage



WARNING

Fire hazard from electrical appliances!

If you use electrical appliances in the food area of your appliance, they can cause a fire.

- ▶ Do not use electrical appliances in the food area of the appliance unless recommended by the manufacturer.

Note

The energy consumption increases and the cooling power goes down if ventilation is not sufficient.

- ▶ Always keep air slots clear.

Observe the following specifications for storage:

- In the freezer compartment: Package food properly.
- Package or cover foods that readily take on or give off odours or taste in closed containers.
- Package raw meat or fish in clean, closed containers. This will prevent meat or fish from touching or dripping onto other food.
- Keep liquids in closed containers.
- Leave space between goods to ensure good air circulation.
- Store food according to the instructions on the packaging.
- Always observe the best-before date indicated on the packaging.

Note

Failure to follow these guidelines can lead to foodstuffs spoiling.

6.2 Fridge compartment

The air circulation in the appliance creates different temperature zones. You will find the different temperature zones in the appliance and equipment overview. (see 2.2 Overview of the appliance and equipment)

6.2.1 Arranging your food properly

- ▶ Upper area and door: Store butter, cheese, tinned food and tubes.
- ▶ Coldest temperature zone: Store perishable foods such as pre-cooked meals, meat and lunch meats.
- ▶ Bottom shelf: Store raw meat or fish.

6.3 EasyFresh

EasyFresh is great for non-packaged foods, such as fruit and vegetables.

Note

- ▶ Store sliced citrus fruit (e.g. lemon or orange slices) in a container.

The humidity inside the drawer depends on the humidity content of the food inside it, and the frequency at which it is opened. The humidity can be regulated. (see 9.6 Compartment lid for EasyFresh Safe)

6.3.1 Arranging your food properly

- ▶ Store unpackaged fruit and vegetables. If the humidity is too high:
- ▶ Regulate the humidity.

6.4 Cellar compartment

The cellar compartment is suitable for storing foods that are sensitive to the cold, such as potatoes, onions or tropical fruits, and for storing foods or beverages that should not be too cold when consumed. The cellar compartment is therefore an optimal replacement for a cellar or pantry.

Saving energy

6.4.1 Arranging your food properly

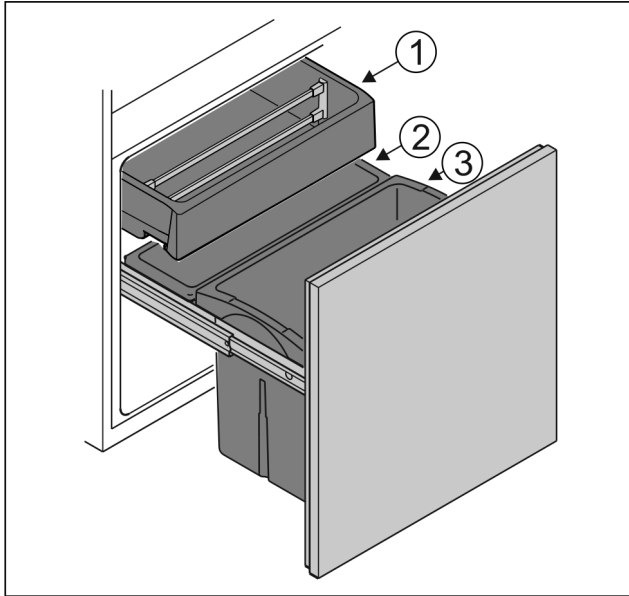

Fig. 68

- ▶ Container Fig. 68 (1): Store unpackaged vegetables and tropical fruits.
- ▶ Container Fig. 68 (2): Store small unpackaged fruits and vegetables.
- ▶ Container Fig. 68 (3): Store individual bottles.

6.5 ****-freezer compartment

Here, a dry, frosty storage climate is created at -18 °C. The frosty storage climate is suitable for storing frozen food for several months, for making ice cubes or freezing fresh food.

The air temperature in the freezer compartment, measured with a thermometer or other measuring device, may fluctuate. Temperature fluctuations are greater in a half-full or empty freezer and it is possible to attain temperatures warmer than -18 °C.

6.5.1 Freezing food

The maximum amount of fresh food that you can freeze within 24 hours is specified on the type plate (see 11.5 Model plate) under "Freezing capacity ... kg/24h".

To ensure that food quickly freezes through, adhere to the following quantities per package:

- Fruit and vegetables up to 1 kg
- Meat up to 2.5 kg

Arranging your food properly



CAUTION

Risk of injury due to broken glass!
Bottles and cans containing drinks may burst when being frozen. This applies particularly to sparkling drinks.

- ▶ Do not freeze bottles and cans containing drinks!
- ▶ Place packaged food in the freezer compartment.

Defrosting food



WARNING

- Risk of food poisoning!
- ▶ Do not re-freeze thawed food.
 - ▶ Use defrosted foodstuff as soon as possible.

You can defrost food in several ways:

- In the fridge compartment
- In the microwave
- In the oven/fan-assisted oven
- At room temperature
- ▶ Take out only as much food as necessary.

6.6 Storage times

Refer to the specified storage times as a guide.

In the case of foods with a minimum shelf life, the date indicated on the packaging still applies.

6.6.1 Fridge section

Always follow the best-before date stated on the packaging.

6.6.2 Freezer compartment

| Recommended shelf-lives for various types of food | | |
|---------------------------------------------------|-----------|----------------|
| Ice cream | at -18 °C | 2 to 6 months |
| Cold cuts, ham | at -18 °C | 2 to 3 months |
| Bread, baked goods | at -18 °C | 2 to 6 months |
| Game, pork | at -18 °C | 6 to 9 months |
| Fatty fish | at -18 °C | 2 to 6 months |
| Lean fish | at -18 °C | 6 to 8 months |
| Cheese | at -18 °C | 2 to 6 months |
| Poultry, beef | at -18 °C | 6 to 12 months |
| Vegetables, fruit | at -18 °C | 6 to 12 months |

7 Saving energy

- Pay attention to good ventilation. Do not cover ventilation holes or grids.
- Do not install the appliance in direct sunlight or near radiators or similar sources of heat.
- If the appliance is installed directly next to an oven, the energy consumption may increase slightly. This is dependent on the service life and usage intensity of the oven.
- Energy consumption depends on the installation conditions, e.g. the ambient temperature. A warmer ambient temperature can increase the energy consumption.
- Open the appliance for as short a time as possible.
- The lower the temperature is set the higher the energy consumption.
- Inserting warm food: allow to cool down to room temperature first.
- For longer periods of absence, use HolidayMode (see HolidayMode).

8 Controls

8.1 Controls and displays

8.1.1 Status display

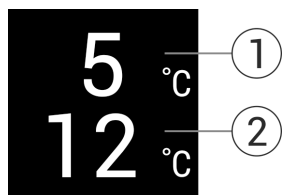

Fig. 69

- (1) Temperature display of the fridge section (2) Temperature display of the larder compartment

The Status display shows the set temperature and is the home display. From there, you can navigate to the options and settings.

8.1.2 Display symbols

Display symbols provide information on the current appliance status:

| Symbol | Appliance status |
|--------|-----------------------------------------------------------------------------------------------------|
| | Standby The appliance or temperature zone is switched off. |
| | Flashing number Appliance is working. Temperature flashes until the set value is reached. |
| | Flashing symbol Appliance is working. Setting is made. |
| | Bar grows steadily Function is activated. |

8.2 Appliance functions

8.2.1 Notes on the appliance functions

The appliance functions are set at the factory so that your appliance is fully functional.

Before you alter, activate or deactivate the device functions, make sure that the following requirements are met:

- You have read and understood the descriptions of how the display works. (see 4 Functionality of the Touch display)
- You have familiarised yourself with the operating and display elements of your appliance.

Switching the appliance off and on

Use this function to switch the entire appliance off and on.

Switching off the appliance

When you switch the appliance off, then the previously saved settings are saved.

Make sure that the following requirements are fulfilled:

- Handling instructions (see 12 Shutting down) are carried out.

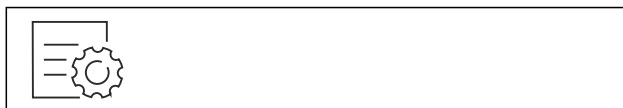

Fig. 70

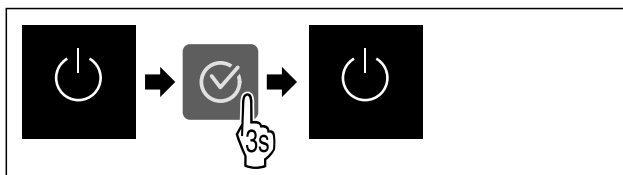

Fig. 71

- ▶ Carry out action steps according to the illustration.
- ▶ Appliance is switched off.
- ▶ The standby symbol appears in the display.
- ▶ Display turns black.

Switching on the appliance

If the display is in sleep mode:

- ▶ Press any navigation key.

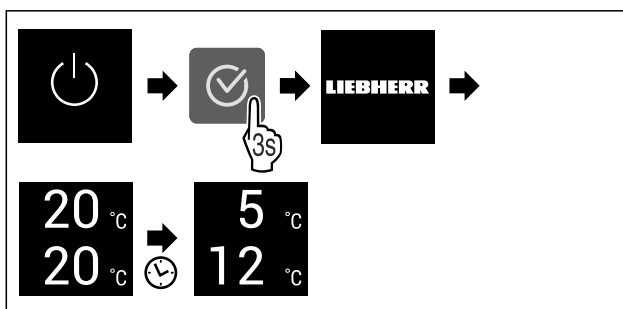

Fig. 72 Example illustration

- ▶ Carry out action steps according to the illustration. When the appliance starts in demo mode:
- ▶ Deactivating demo mode. (see Deactivating demo mode)
- ▶ The appliance is switched on.
- ▶ Previous settings are restored.
- ▶ The appliance cools to the target temperature set.



Switching temperature zone off and on

You can switch temperature zones of the appliance off independently.

Application:

- Cleaning
- Defrosting

Switching the fridge compartment off

Make sure that the following requirements are fulfilled:

- Refrigerator compartment has been emptied.

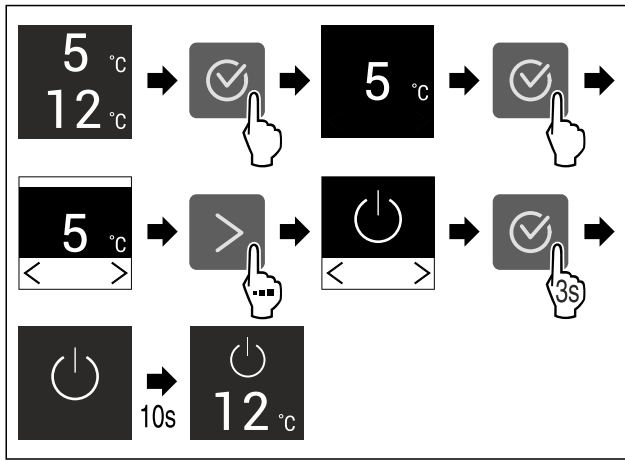

Fig. 73 Example illustration

- ▶ Carry out action steps according to the illustration.
- ▶ Refrigerator compartment is switched off.

Switching the fridge compartment on

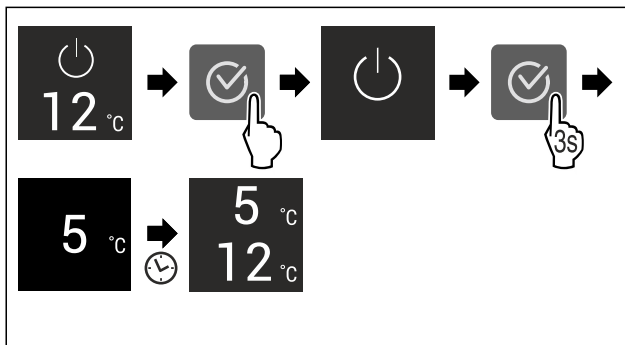

Fig. 74 Example illustration

- ▶ Carry out action steps according to the illustration.
- ▶ Refrigerator compartment is switched on.
- ▶ The appliance cools to the last set temperature.

5 °C Temperature

Use this function to set the temperature.

The temperature depends on the following factors:

- Frequency of door opening
- Duration of door opening
- Room temperature of the installation site
- Type, temperature and quantity of food

| Temperature zone | Factory-set temperature | Recommended setting |
|--------------------------|-------------------------|---------------------|
| 5 °C Fridge section | 5 °C | 4 °C |
| 12 °C Cellar compartment | 12 °C | 12 °C |

Setting the temperature in the fridge section

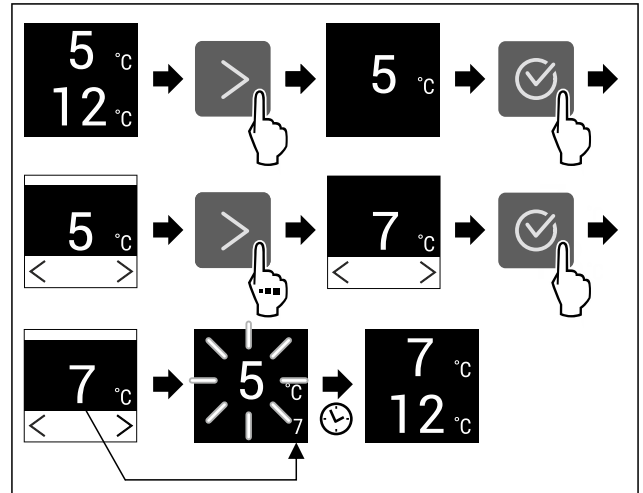

Fig. 75 Example illustration

- ▶ Carry out action steps according to the illustration.
- ▶ Temperature is set.

Setting the temperature in the cellar compartment

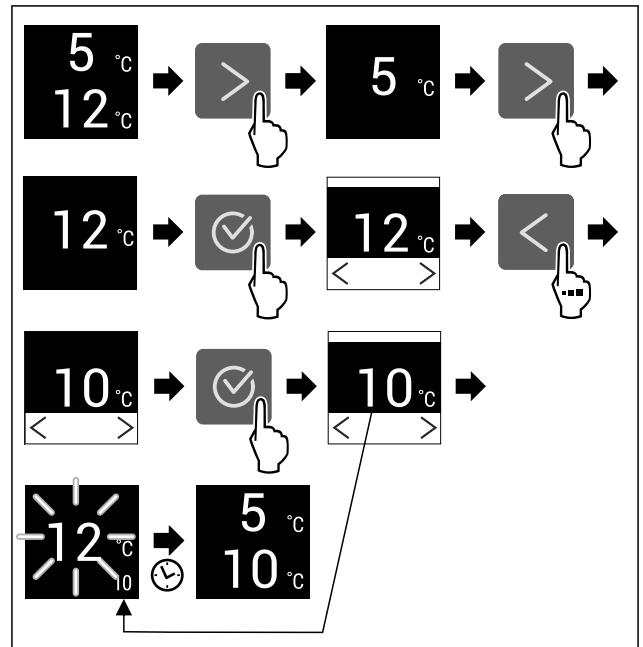

Fig. 76 Example illustration

- ▶ Carry out action steps according to the illustration.
- ▶ Temperature is set.

SuperCool

You can use this function to activate or deactivate SuperCool. If SuperCool is activated, then the appliance increases the cooling capacity. It allows you to achieve lower cooling temperatures. You can activate SuperCool when you would like to cool a large quantity of food quickly.

If SuperCool is activated, then lower temperatures are reached in the **** freezer compartment. You can activate SuperCool when you would like to freeze food in the **** freezer compartment.

If the function is active, the appliance operates at higher power. As a result, the appliance's operating noise may be temporarily louder and energy consumption will increase.

Activating SuperCool

Time for activation of the function:

- When you would like to store fresh food in the fridge section: Activate the function when inserting food.
- When you would like to store fresh food in the **** freezer compartment: Activate the function when inserting food.

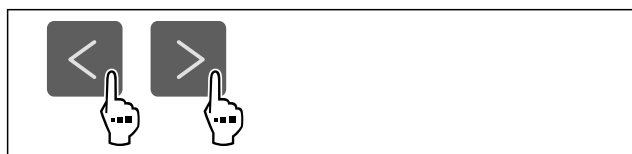

Fig. 77

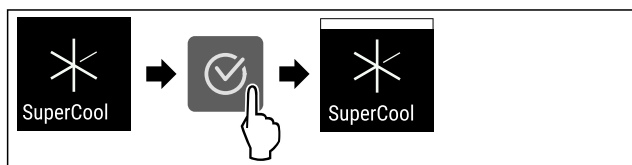

Fig. 78

- ▶ Carry out action steps according to the illustration.
- ▶ SuperCool is activated.

Deactivating SuperCool

SuperCool is deactivated automatically after 18 hours. However, you can also deactivate SuperCool manually at any time:

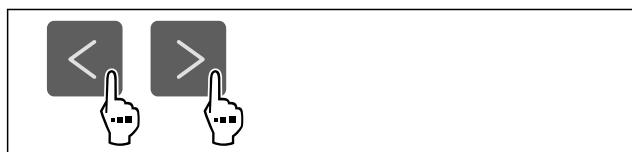

Fig. 79

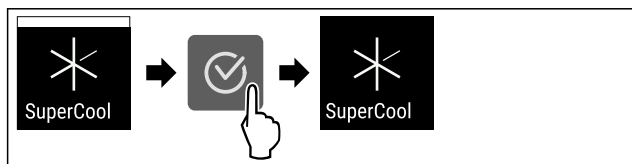

Fig. 80

- ▶ Carry out action steps according to the illustration.
- ▶ SuperCool is deactivated.
- ▶ The appliance continues to run in normal mode.
- ▶ The appliance cools to the temperature set previously.

PartyMode

You can use this function to activate or deactivate PartyMode. PartyMode activates various functions that are useful for a party.

PartyMode activates the following functions:

- SuperCool (see SuperCool)

You can adjust all listed functions individually and flexibly. When you deactivate PartyMode, all changes are discarded.

If the function is active, the device operates at higher power. As a result, the device's operating noise may be temporarily louder and energy consumption will increase.

Activating PartyMode



Fig. 81

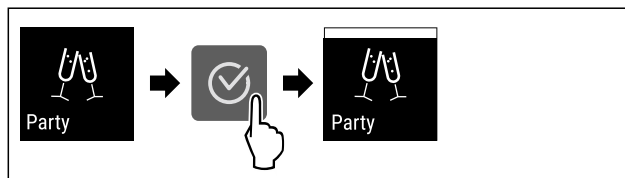

Fig. 82

- ▶ Carry out action steps according to the illustration.
- ▶ PartyMode and the associated functions are activated.
- ▶ The current temperature flashes until the target temperature is reached.

Deactivating PartyMode

The PartyMode is automatically deactivated after 24 seconds. However, you can also deactivate PartyMode manually at any time:



Fig. 83

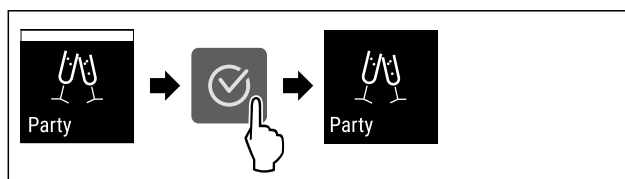

Fig. 84

- ▶ Carry out action steps according to the illustration.
- ▶ PartyMode is deactivated.
- ▶ The appliance cools to the temperature set previously: The current temperature flashes until the target temperature is reached.



HolidayMode

You can use this function to activate or deactivate HolidayMode. If you activate HolidayMode, the fridge section is set to 15 °C. This saves you energy during longer periods of absence and prevents bad odours and growth of mould.

| Appliance status when HolidayMode is active |
|--------------------------------------------------------------------|
| Fridge section cools to 15 °C. |
| EasyFresh cools to 15 °C. |
| The set temperature is maintained in the **** freezer compartment. |
| The set temperature is maintained in the cellar compartment. |
| PartyMode is deactivated. |
| SuperCool is deactivated. |

Activating HolidayMode

- ▶ Empty the fridge section completely.
- ▶ Empty EasyFresh completely.

Controls

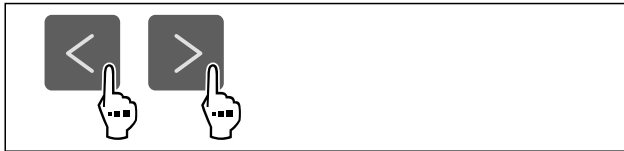

Fig. 85

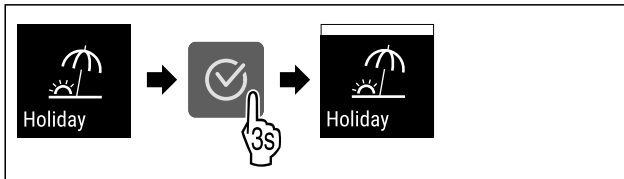

Fig. 86

- ▶ Carry out action steps according to the illustration.
- ▶ HolidayMode is activated.
- ▶ Temperature display shows HolidayMode symbol.

Deactivating HolidayMode

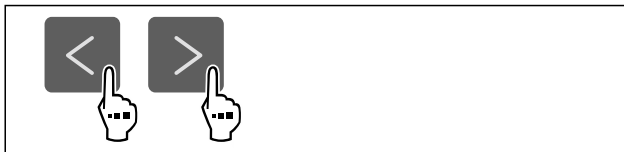

Fig. 87

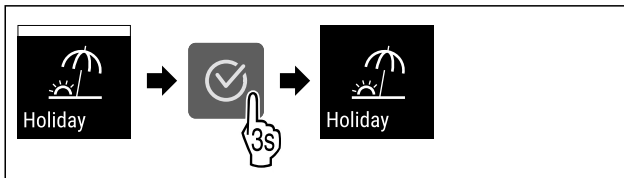

Fig. 88

- ▶ Carry out action steps according to the illustration.
- ▶ HolidayMode is deactivated.
- ▶ The appliance cools to the temperature set previously.



SabbathMode

You can use this function to activate or deactivate SabbathMode. If you activate this function, some electronic functions are switched off. As a result, your device meets the religious requirements for Jewish holidays such as Sabbath and complies with STAR-K Kosher certification.

| |
|-----------------------------------------------------------------------------------------------------------|
| Device status when SabbathMode is active |
| The status display shows SabbathMode permanently. |
| All functions on the display are locked except for the Deactivate SabbathMode function . |
| Active functions remain active. |
| The display remains bright when you close the door. |
| The interior lighting is deactivated. |
| Reminders are not implemented. The set time interval stops. |
| Reminders and warnings are not displayed. |
| There is no door alarm. |
| There is no temperature alarm. |
| The defrosting cycle operates only for the specified time, without considering the appliance consumption. |

Device status when SabbathMode is active

After a power failure, the appliance returns to SabbathMode.

Device status

Note

This appliance has certification from the "Institute for Science and Halacha". (www.machonhalacha.co.il)

You can find a list of STAR-K-certified appliances at www.star-k.org/appliances.

Activating SabbathMode



WARNING

Danger of food poisoning from spoiled food! If you have SabbathMode activated and a power failure occurs, no message appears in the status display about the power failure. Once the power is restored, the appliance continues to operate in SabbathMode. The power failure may mean that food spoils and the consumption of this food could lead to food poisoning.

After a power failure:

- ▶ Do not consume food that was frozen and has thawed out.



Fig. 89

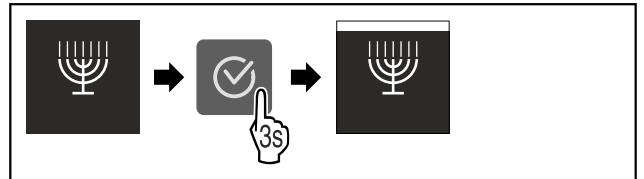

Fig. 90

- ▶ Carry out action steps according to the illustration.
- ▶ SabbathMode is activated.
- ▶ The status display shows SabbathMode permanently.

Deactivating SabbathMode

The SabbathMode is automatically deactivated after 80 hours. However, you can also deactivate SabbathMode manually at any time:

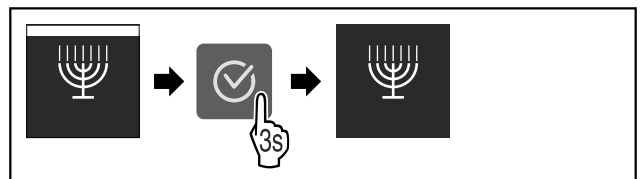

Fig. 91

- ▶ Carry out action steps according to the illustration.
- ▶ SabbathMode is deactivated.



E-Saver

You can use this function to activate or deactivate Energy saving mode. If energy saving mode is activated, the energy consumption decreases and the temperature in the device increases. The food remains fresh, but the shelf life is shortened.

| Temperature zone | Recommended setting (see Setting the temperature in the fridge section) | Temperature with active E-Saver |
|---------------------|-------------------------------------------------------------------------|---------------------------------|
| 5 °C Fridge section | 4 °C | 7 °C |

Temperatures

Activating E-Saver



Fig. 92

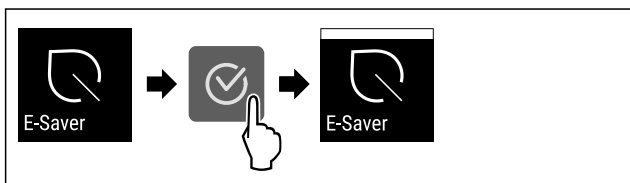

Fig. 93

- ▶ Carry out action steps according to the illustration.
- ▶ Energy saving mode is activated.

Deactivating E-Saver

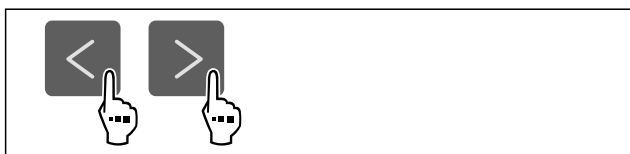

Fig. 94

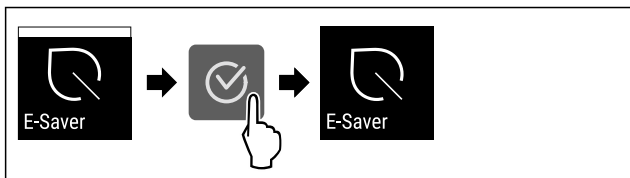

Fig. 95

- ▶ Carry out action steps according to the illustration.
- ▶ Energy saving mode is deactivated.

CleaningMode

You can use this function to activate or deactivate CleaningMode. CleaningMode enables the appliance to be cleaned conveniently.

This setting applies to the fridge section.

Application:

- Clean the fridge section. (see 10.5 Cleaning the appliance)

| |
|----------------------------------------------------------------------|
| Device status when CleaningMode is active |
| The status display shows CleaningMode permanently. |
| The fridge section is switched off. |
| Interior lighting is activated. |
| The reminders and warnings are not displayed. No signal tone sounds. |

Device status

Activating CleaningMode



Fig. 96

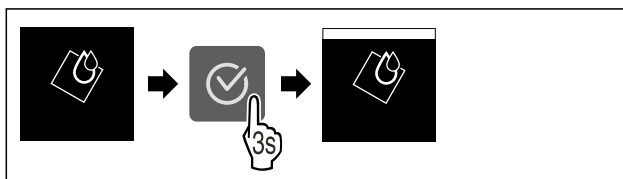

Fig. 97

- ▶ Carry out action steps according to the illustration.
- ▶ CleaningMode is activated.
- ▶ The status display shows CleaningMode permanently.

Deactivating CleaningMode

CleaningMode is deactivated automatically after 60 minutes. However, you can also deactivate CleaningMode manually at any time:

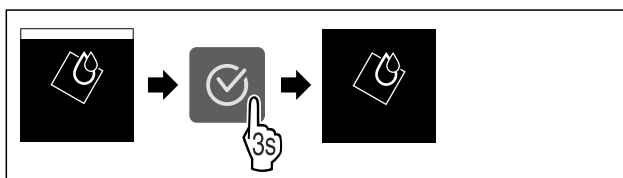

Fig. 98

- ▶ Carry out action steps according to the illustration.
- ▶ CleaningMode is deactivated.
- ▶ The appliance cools to the temperature set previously.

Input lock

You can use this function to activate or deactivate the input lock. The input lock prevents the appliance being operated accidentally, e.g. by children.

Application:

- Avoid unintentional modification of functions.
- Avoid unintentional switching off of the device.
- Avoid unintentional temperature setting.

Activating the input lock

If you activate the input lock, you can continue to navigate in the menus but you cannot select or change other functions.



Fig. 99

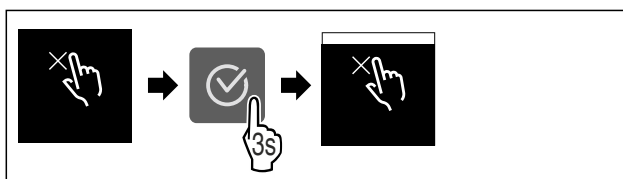

Fig. 100

- ▶ Carry out action steps according to the illustration.
- ▶ Input lock is activated.

Controls

Deactivating the input lock



Fig. 101

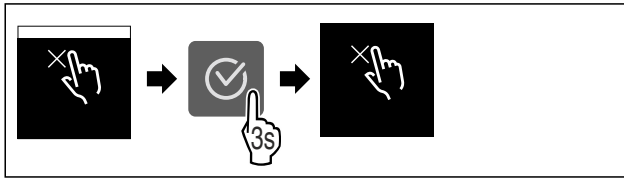

Fig. 102

- ▶ Carry out action steps according to the illustration.
- ▷ Input lock is deactivated.

Temperature unit

Use this function to set the temperature unit. You can set degrees Celsius or degrees Fahrenheit as the temperature unit.

Setting the temperature unit



Fig. 103

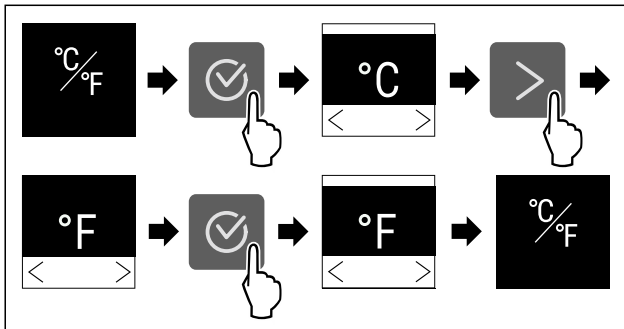

Fig. 104 Example illustration: Switch from degrees Celsius to degrees Fahrenheit.

- ▶ Carry out action steps according to the illustration.
- ▷ The temperature unit is set.

Display brightness

Use this function to set the display brightness in stages.

You can select the following brightness levels:

- 40 %
- 60 %
- 80 %
- 100 % (pre-setting)

Setting the brightness



Fig. 105

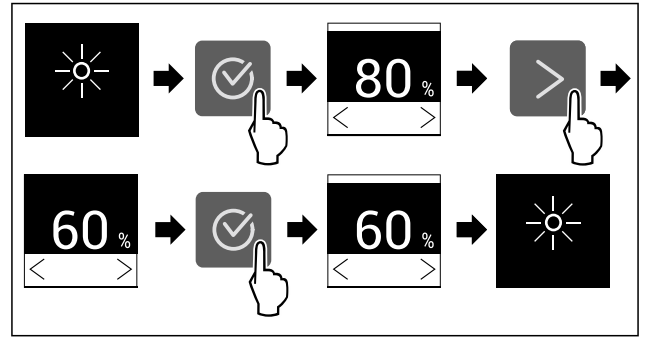

Fig. 106 Example illustration: Switch from 80 % to 60 %.

- ▶ Carry out action steps according to the illustration.
- ▷ The brightness is set.

WiFi

Use this function to connect your appliance to WiFi. You can then operate it via the SmartDevice app on a mobile device. You can also use this function to disconnect or reset the WiFi connection.

To connect your device to WiFi, you need the SmartDeviceBox.

More information on the SmartDevice: (see 2.3 SmartDevice)

Note

The SmartDevice function is not available in the following countries: Russia, Belarus, Kazakhstan.

You cannot use the SmartDeviceBox.

Establishing the WiFi connection for the first time

Make sure that the following requirements are fulfilled:

- You have purchased and inserted a SmartDeviceBox. (see 2.3 SmartDevice)
- You have installed the SmartDevice app (see apps.home.liebherr.com).
- Registration in the SmartDevice app is completed.



Fig. 107

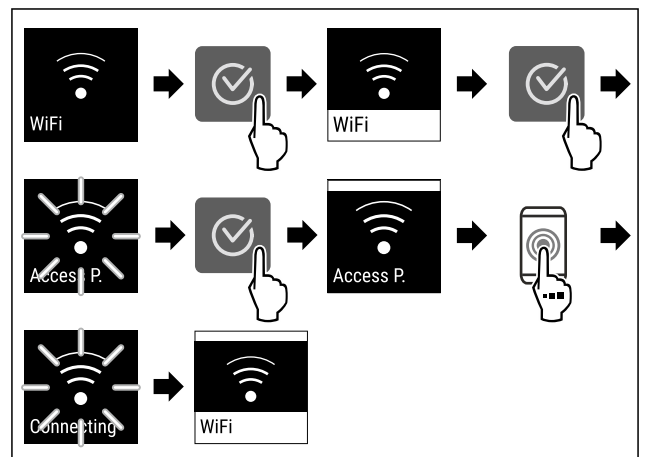

Fig. 108

- ▶ Carry out action steps according to the illustration.
- ▷ Connection is established.

Disconnecting from the WiFi



Fig. 109

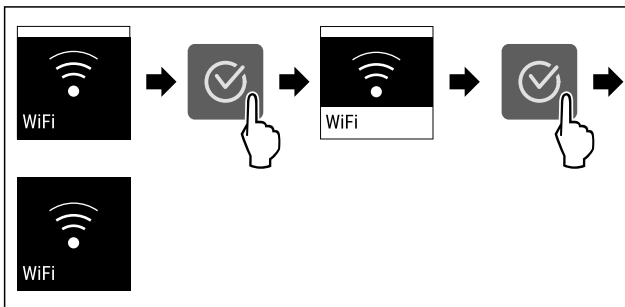

Fig. 110

- ▶ Carry out action steps according to the illustration.
- ▶ There is no connection.

Resetting the WiFi connection



Fig. 111

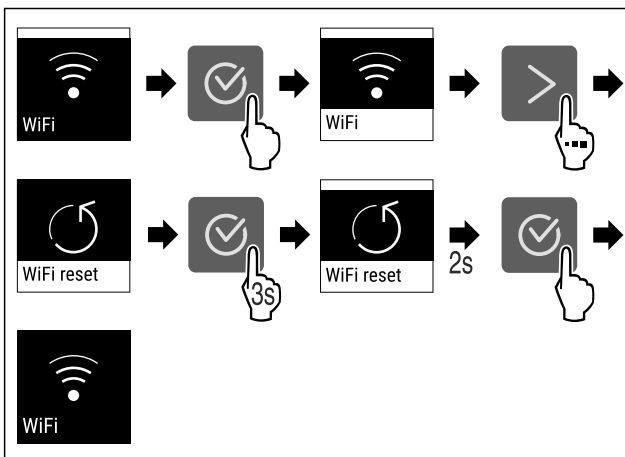

Fig. 112

- ▶ Carry out action steps according to the illustration.
- ▶ WiFi connection and other WiFi settings are reset to factory settings.

Showing information about the WiFi connection



Fig. 113

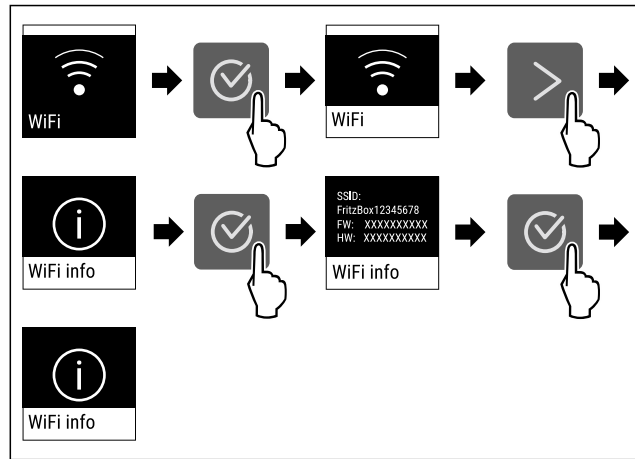

Fig. 114

- ▶ Carry out action steps according to the illustration.



Device information

Use this function to indicate the model name, index, serial number and service number of your device. You will need the device information when you contact customer service. (see 11.4 Customer Service)

This function also opens the Advanced menu. (see 4 Functionality of the Touch display)

Indicating the device information



Fig. 115



Fig. 116

- ▶ Carry out action steps according to the illustration.
- ▶ Display indicates device information.



Software

Use this function to indicate the software version of your device.

Indicating the software version



Fig. 117

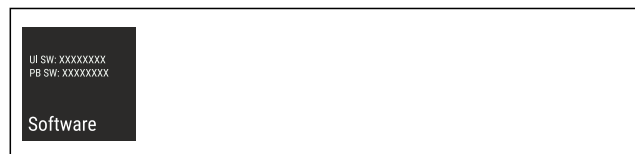

Fig. 118

- ▶ Carry out action steps according to the illustration.
- ▶ Display indicates software version.

Controls



Door alarm

Use this function to activate or deactivate the door alarm. The door alarm sounds if the door is open for too long. The door alarm is activated on delivery. You can set how long the door may be open before the door alarm sounds.

The following values can be set:

- 1 minute
- 2 minutes
- 3 minutes
- Off

Setting the door alarm



Fig. 119

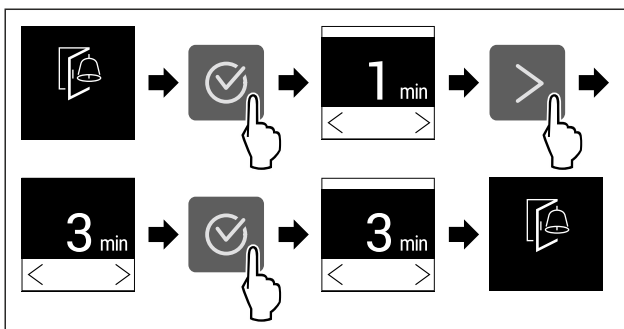

Fig. 120 Example illustration: Change door alarm from 1 minute to 3 minutes.

- ▶ Carry out action steps according to the illustration.
- ▶ The door alarm is set.

Deactivating the door alarm



Fig. 122

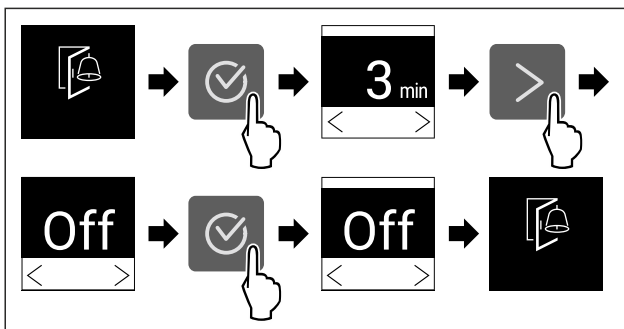

Fig. 123

- ▶ Carry out action steps according to the illustration.
- ▶ The door alarm is deactivated.



Demo mode

Demo mode is a special feature for dealers who want to demonstrate appliance features. If you activate demo mode, all refrigeration functions are deactivated.

If you switch on your appliance and “Demo” appears in the status display, then demo mode is already activated.

If you activate and then deactivate demo mode, the appliance will be reset to factory defaults. (see Resetting to factory settings)

Activating demo mode



Fig. 124

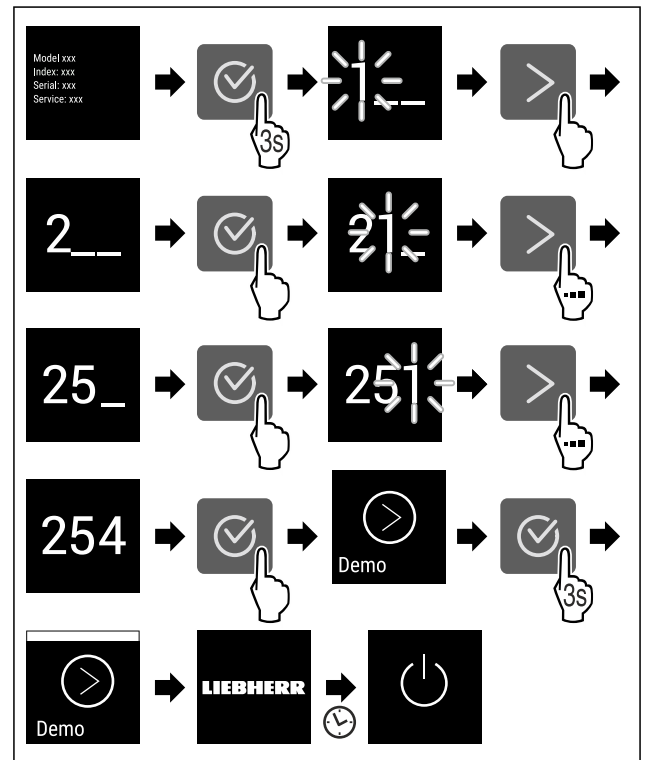

Fig. 125

- ▶ Carry out action steps according to the illustration.
- ▶ Demo mode is activated.
- ▶ Appliance is switched off.
- ▶ Switch on the appliance. (see 5.1 Switching on appliance (first use))
- ▶ “DEMO” appears in the status display.

Deactivating demo mode



Fig. 126

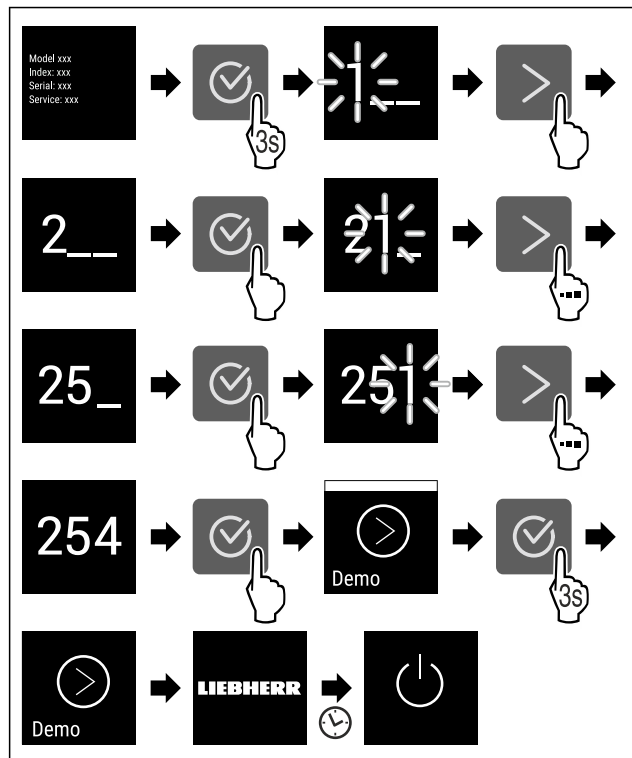

Fig. 127

- ▶ Carry out action steps according to the illustration.
- ▶ Demo mode is deactivated.
- ▶ Appliance is switched off.
- ▶ Switch on the appliance. (see 5.1 Switching on appliance (first use))
- ▶ Appliance is reset to factory settings.

Resetting to factory settings

Use this function to reset all settings to factory defaults. All settings you have made so far are reset to their original settings.

Performing a reset



Fig. 128

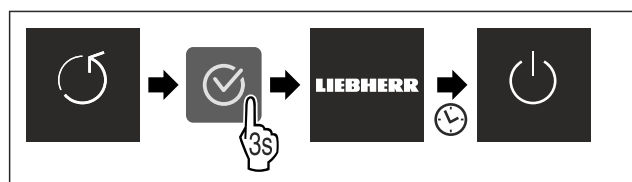

Fig. 129

- ▶ Carry out action steps according to the illustration.
- ▶ Device is reset.
- ▶ Device is switched off.
- ▶ Restart the device. (see 5.1 Switching on appliance (first use))

8.3 Messages

There are two categories of messages:

| Category | Importance |
|----------|--------------------------------------------------------------------------------------------------------------------------------------------------------------------------------------------------------------------|
| Warning | Warnings appear in the event of a door alarm or malfunction. Simple warnings can be cancelled by yourself. In the event of serious malfunctions, you must contact customer service. (see 11.4 Customer Service) |
| Reminder | Reminders remind you of general processes. You can carry out these operations to end the message. |

8.3.1 Overview of warnings

Behaviour of the appliance in the event of warnings:

- Warning appears on the display.
- The alarm tone sounds at an ever-increasing volume.
- The interior lighting pulsates for some warnings.

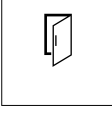
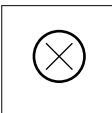
| Message | Cause | Exit the message |
|--------------------------------------------------------------------------------------------------------|-----------------------------------------------------------------------------------------------|------------------------------------------|
|  Door alarm | The message appears if the door is open for too long. | Carry out action steps. (see Door alarm) |
|  Error | The message appears if there is an appliance error. A component of the appliance has a fault. | Carry out action steps. (see Error) |

8.3.2 Ending warnings

Door alarm

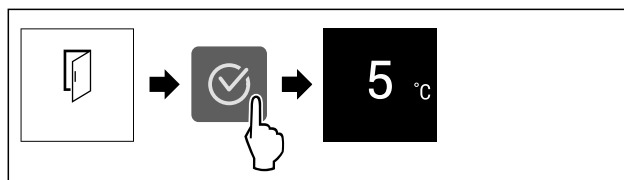

Fig. 130 Example illustration

- ▶ Carry out action steps according to the illustration.
- or-
- ▶ Close the door.

▶ The display returns to the status indicator.

You can set how long the door may be open before the door alarm sounds. (see Setting the door alarm)

Error

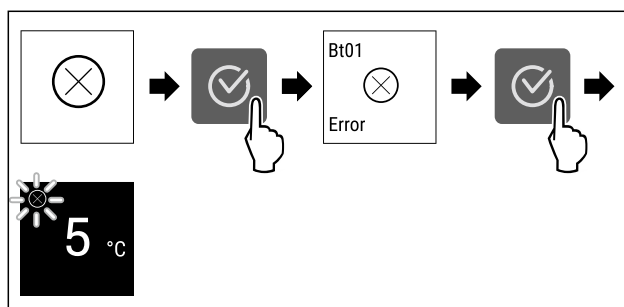

Fig. 131 Example illustration

- ▶ Press the confirmation symbol.
- ▶ Error code is displayed.
- ▶ Note the error code.
- ▶ Press the confirmation symbol.

Features

- ▶ The display returns to the status indicator.
- ▶ Contact Customer Service. (see 11.4 Customer Service)

8.3.3 Overview of reminders

Behaviour of the appliance during reminders:

- Reminder appears on the display.
- Alarm tone sounds.
- The interior lighting pulsates for some reminders.

9 Features

9.1 4-star freezer compartment

9.1.1 Opening/closing the freezer compartment

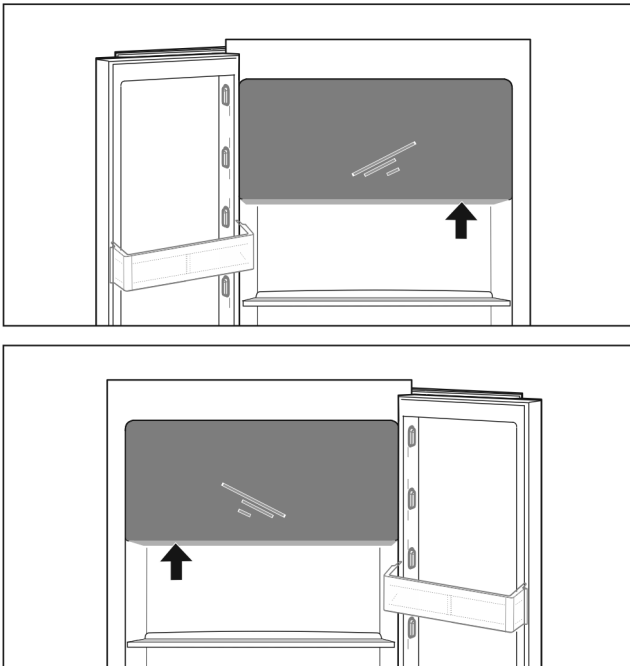

Fig. 132

Opening the freezer compartment:

- ▶ Reach into the handle area from below.
- ▶ Push the handle plate while pulling the door towards you.

Closing the freezer compartment:

- ▶ Close the door while pushing from the front.
- ▶ Door is engaged.

9.2 Door rack

Door racks are suitable for storing drinks and food. You can move door racks for your own individual use and take them apart for cleaning. However, Liebherr recommends using the door racks in the position in the door as delivered from the factory.

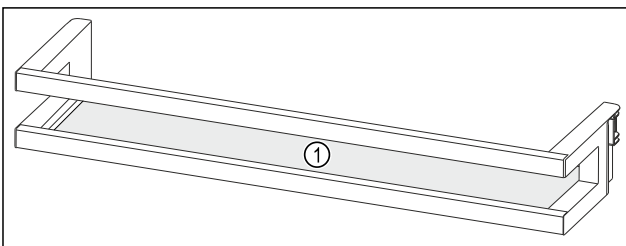

Fig. 133 Example illustration, Door rack
(1) Shelf

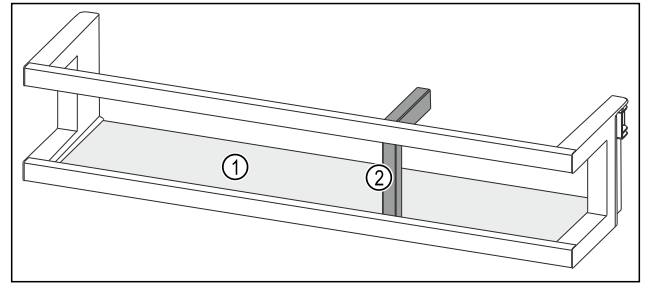

Fig. 134 Example illustration, Door rack with bottle holder
(1) Shelf (2) Bottle holder

The following table shows examples of what can be stored in each door rack. Do not exceed the maximum loading weight of the door.

| Door rack | Food |
|---------------------------------------------|----------------------------------------------------------------------------|
| Door rack (see Fig. 133) | Butter, cheese, tinned food, tubes |
| Door rack with bottle holder (see Fig. 134) | Bottles The sliding bottle holder secures the bottles in the door rack. |

9.2.1 Removing the door rack

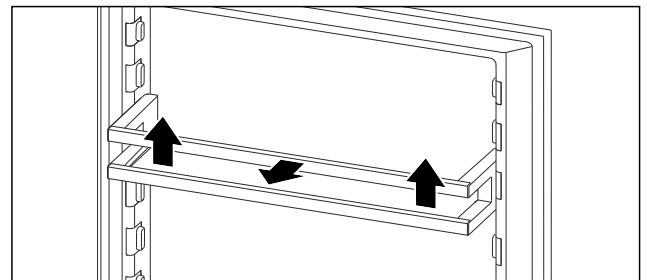

Fig. 135 Example illustration

- ▶ Push the door rack upwards.
- ▶ Pull the door rack forward.

9.2.2 Inserting the door rack

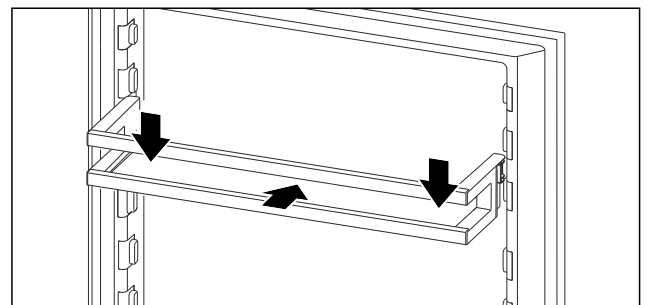

Fig. 136 Example illustration

- ▶ Slide in the door rack.
- ▶ Press the door rack down.

9.3 Shelves

9.3.1 Adjusting/removing the shelves

The shelves are prevented from being pulled out accidentally by pull out stops.

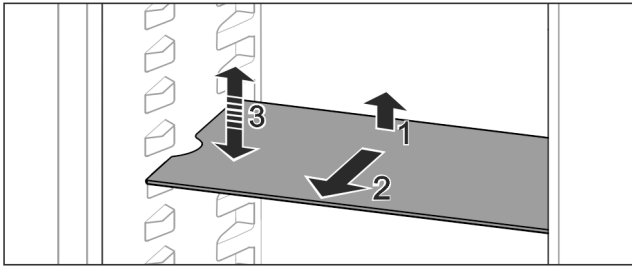

Fig. 137

- ▶ Lift the shelf and pull forward.
- ▶ Line up the side runner.
- ▶ Adjust the height of the shelf: Lift or lower it to the desired height and slide it in.

-or-

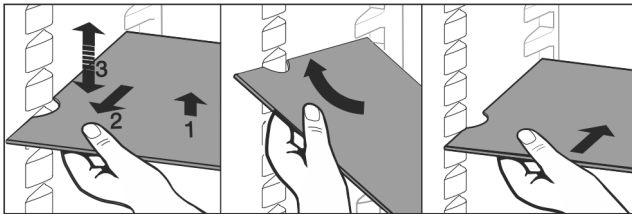

Fig. 138

- ▶ Remove the shelf completely: Pull it out to the front.
- ▶ Easier removal: Set the shelf at an angle.
- ▶ Insert the shelf again: Slide it in all the way.
- ▶ The pull-out stoppers point downwards.
- ▶ The pull-out stoppers are behind the front support.

You can also remove the shelf above the EasyFresh compartments.

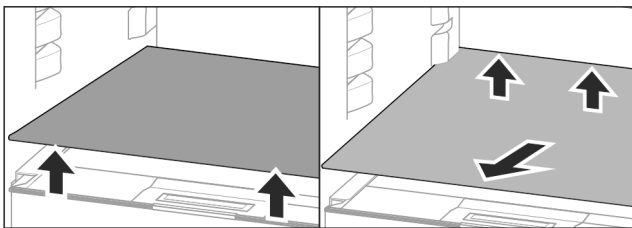

Fig. 139

Removing the shelf:

- ▶ Lift the shelf at the front and back.
- ▶ Pull it out towards you.

Do not store any goods on the compartment cover below!

Inserting the shelf:

- ▶ Place the shelf at an angle, sloping down towards the back.
- ▶ The pull-out stoppers point downwards.
- ▶ Slide the shelf into place.

9.3.2 Dismantling the shelves

The shelves can be dismantled for cleaning.

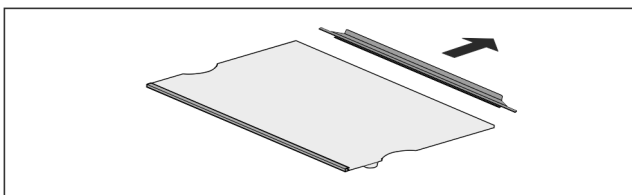

Fig. 140

- ▶ Dismantling the shelf.

9.4 Dividing shelf

9.4.1 Using the dividing shelf

The shelves are prevented from being pulled out accidentally by pull out stops.

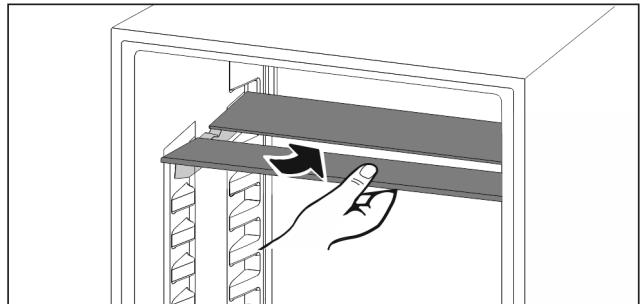

Fig. 141

- ▶ Push the dividing shelf underneath as shown.

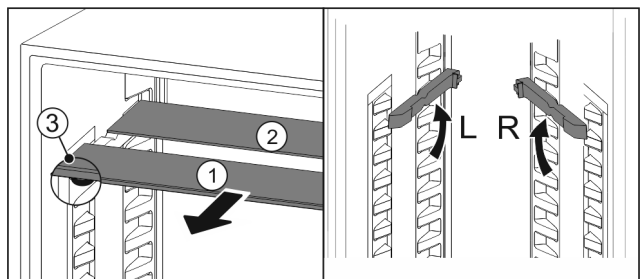

Fig. 142

Adjusting the height:

- ▶ Pull the glass panels out Fig. 142 (1) from the front, one at a time.
- ▶ Release the support rails and click in at the height you want.
- ▶ Slide in the glass panels one at a time.
- ▶ Flat pull-out stoppers at the front, right behind the support rails.
- ▶ High pull-out stoppers at the back.

Using both shelves:

- ▶ Hold the glass panel with one hand and pull it to the front.
- ▶ The glass panel Fig. 142 (1) and trim strip are at the front.
- ▶ The stops Fig. 142 (3) point down.

9.5 Drawers

You can remove the drawers for cleaning.

The way to remove/insert the drawers varies depending on the pull-out system. Your appliance can contain various pull-out systems.

Note

The energy consumption increases and the cooling power goes down if ventilation is not sufficient.

- ▶ Always keep the inside vents at the rear wall clear.

9.5.1 Drawer on telescopic rails

The drawer runs on extendible rails (telescopic rails). There are fully extendible telescopic rails and telescopic rails with partial pull-out. Drawers which are fully extendible can be pulled out fully from the appliance. Drawers with partial pull-out cannot be removed fully from the appliance. The system in your appliance depends on the type of appliance.

Fully extendible*

If you have fully extendible rails, there is a clamp located at the back on the left and right of the rail.

Features

Removing drawer

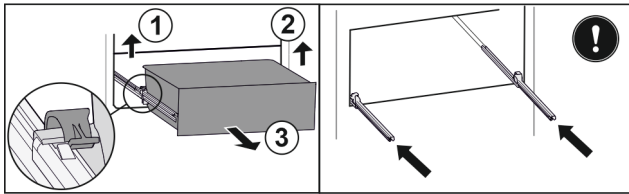

Fig. 143

- ▶ Pull out drawer as far as it will go.
- ▶ Lift left clamp and simultaneously pull drawer forwards on the left. Fig. 143 (1)
- ▶ Lift right clamp and simultaneously pull drawer forwards on the right. Fig. 143 (2)
- ▶ Remove drawer to the front. Fig. 143 (3)
- ▶ Slide rails in.

Inserting drawer

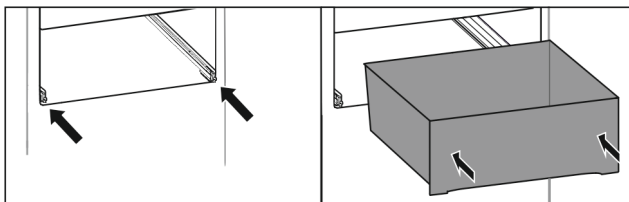

Fig. 144

- ▶ Slide rails in.
- ▶ Place drawer on rails.
- ▶ Slide in drawer to the back.
- ▶ Drawer latches in audibly at the back.

Partial pull-out fridge compartment*

Removing drawer

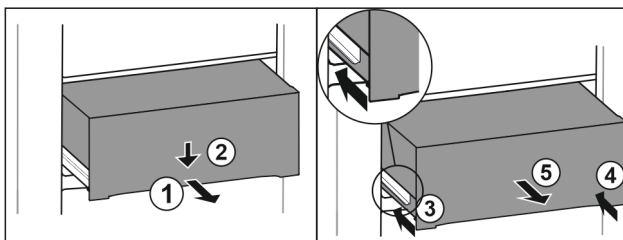

Fig. 145

- ▶ Pull out drawer half-way. Fig. 145 (1)
- ▶ Push the drawer down at the front. Fig. 145 (2)
- ▶ Push the left rail in by about 2 cm. Fig. 145 (3)
- ▶ Push the right rail in by about 2 cm. Fig. 145 (4)
- ▶ Remove drawer to the front. Fig. 145 (5)

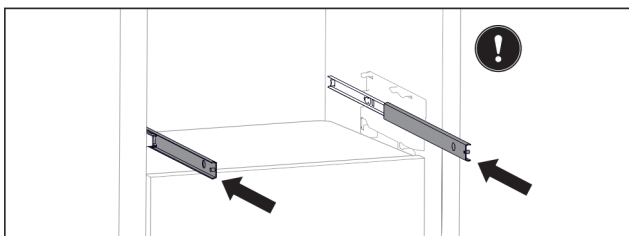

Fig. 146

If the rails are not yet fully inserted after removing the drawer:

- ▶ Push rails in completely.

Inserting drawer

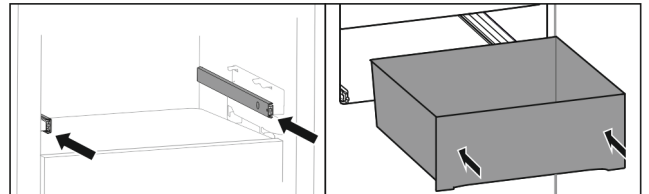

Fig. 147

- ▶ Slide rails in.
- ▶ Place drawer on rails.
- ▶ Slide in drawer to the back.

9.5.2 Pull-out unit

Note

The drawer above the pull-out unit is fully extendible. (see Fully extendible*)

Removing drawer

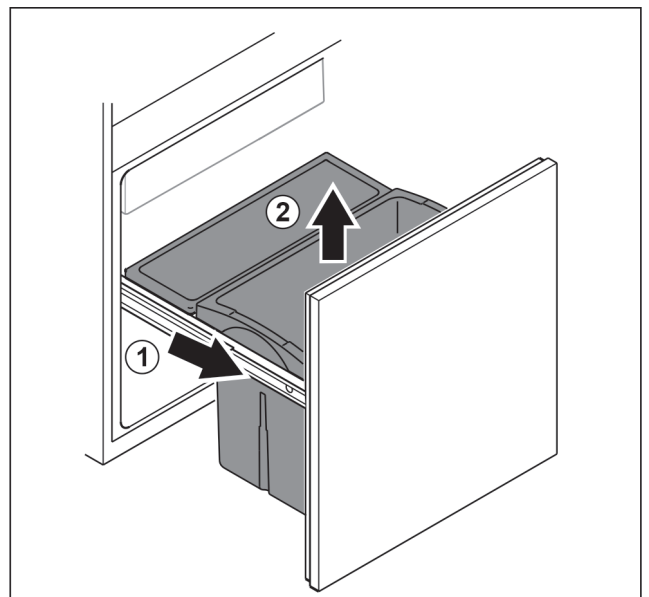

Fig. 148

- ▶ Remove the pull-out unit as far as it will go. Fig. 148 (1)
- ▶ Remove drawer upwards. Fig. 148 (2)

Inserting drawer

- ▶ Remove the pull-out unit as far as it will go.

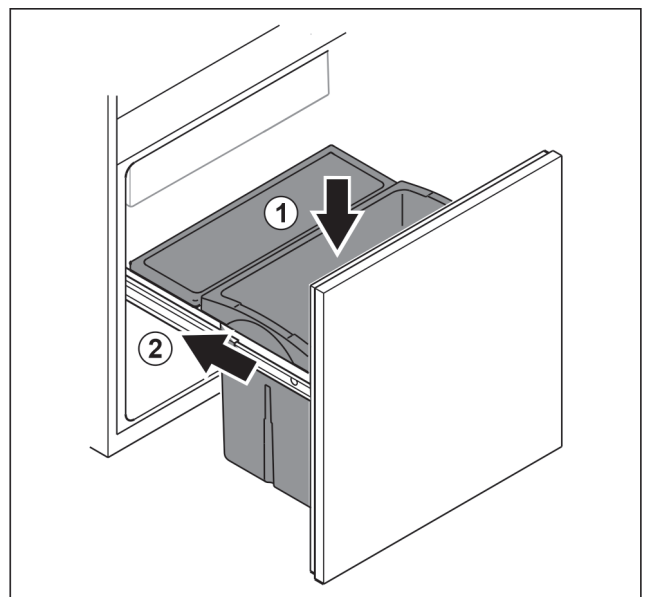

Fig. 149

- ▶ Insert drawer from above. Fig. 149 (1)
- ▶ Slide in pull-out unit. Fig. 149 (2)

9.6 Compartment lid for EasyFresh Safe

The compartment lid ensures constant levels of humidity. The compartment lid is directly on the drawer and can be covered by shelves or additional drawers.

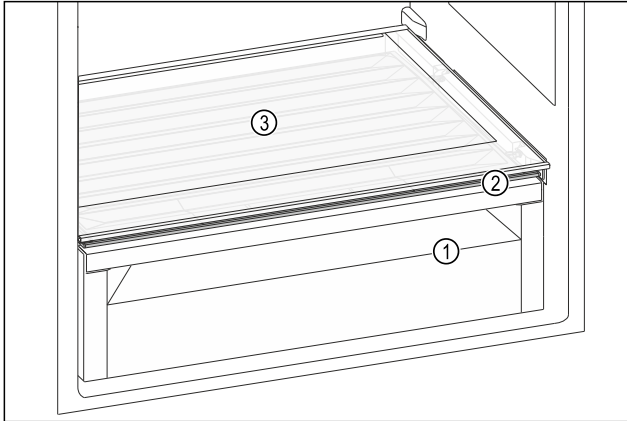

Fig. 150 Example illustration, compartment lid for EasyFresh Safe

- (1) EasyFresh Safe
- (2) Compartment lid for EasyFresh Safe
- (3) Shelf

9.6.1 Reducing the air humidity in the drawer

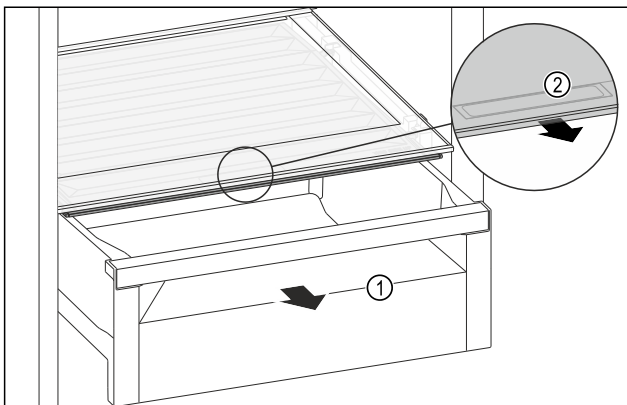

Fig. 151

- ▶ Pull out the drawer Fig. 151 (1).
- ▶ Grasp the recessed grip Fig. 151 (2) on the compartment lid and pull the compartment lid forwards at the same time.
- ▶ When the drawer is closed, there is a small gap between the compartment lid and the drawer.

9.6.2 Increasing the air humidity in the drawer

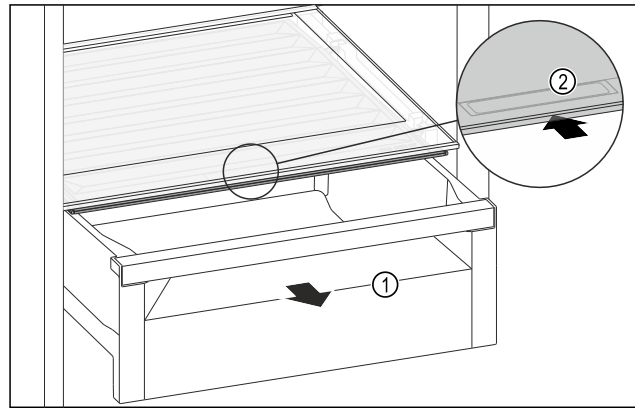

Fig. 152

- ▶ Pull out the drawer Fig. 152 (1).
- ▶ Grasp the recessed grip Fig. 152 (2) on the compartment lid and push the compartment lid backwards at the same time.
- ▶ When the drawer is closed, the compartment lid seals with the drawer.

9.7 Pull-out unit

Note

The drawer above the pull-out unit is fully extendible. (see Fully extendible*)

9.7.1 Removing drawer

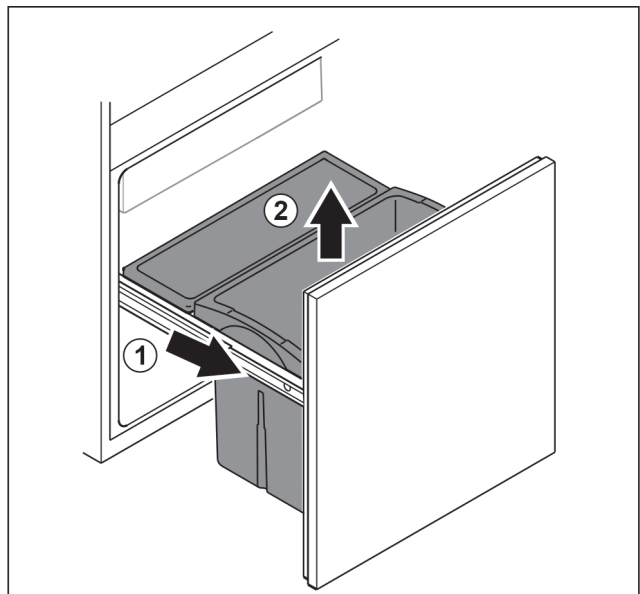

Fig. 153

- ▶ Remove the pull-out unit as far as it will go. Fig. 153 (1)
- ▶ Remove drawer upwards. Fig. 153 (2)

9.7.2 Inserting drawer

- ▶ Remove the pull-out unit as far as it will go.

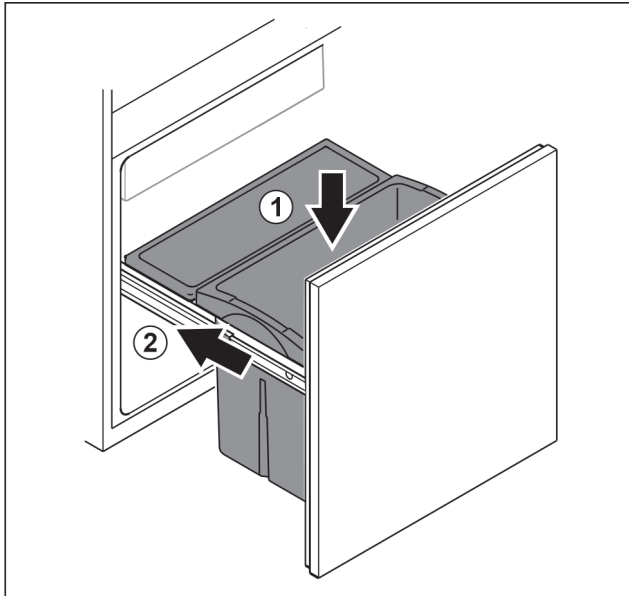

Fig. 154

- ▶ Insert drawer from above. Fig. 154 (1)
- ▶ Slide in pull-out unit. Fig. 154 (2)

9.8 Bottle holder

9.8.1 Using the bottle holder

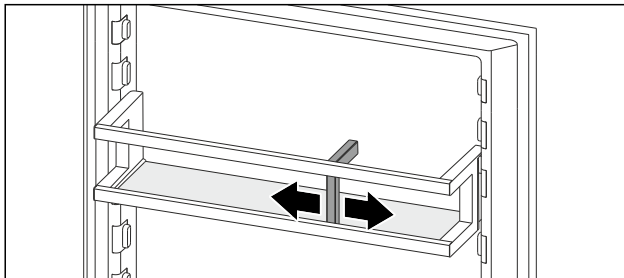

Fig. 155

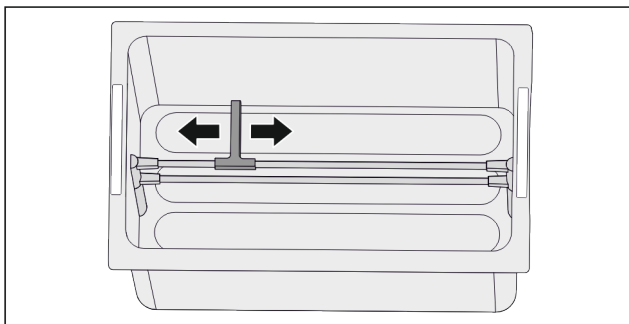

Fig. 155

- ▶ Push the bottle holder onto the bottles.
- ▶ The bottles are prevented from falling over.

9.9 FlexCube

The FlexCube has different sized openings, so you can store small items such as tubes, open yoghurt pots or quail eggs in it. The FlexCube fits into all Liebherr door racks, for example. If necessary, you can also set up several FlexCubes next to each other.

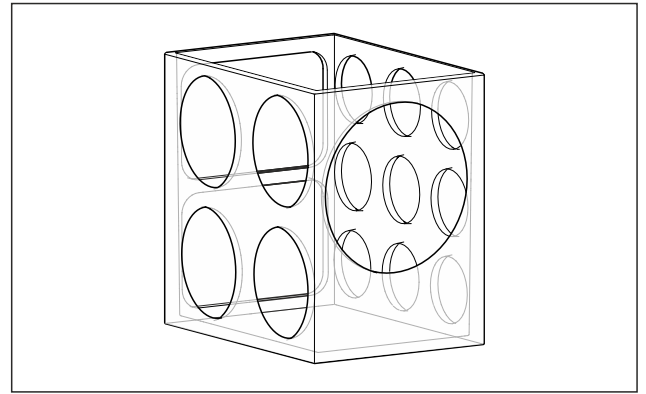

Fig. 156 Example illustration

Note

These accessories can be purchased from the Liebherr-Hausgeräte shop at home.liebherr.com/shop/de/deu/zubehor.html.

9.9.1 Using the FlexCube

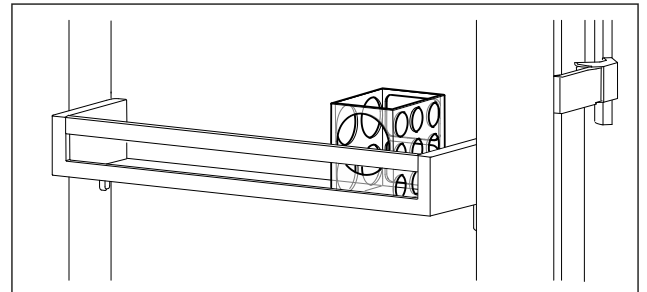

Fig. 157 Example illustration

- ▶ Insert the FlexCube in the door rack.
- or-

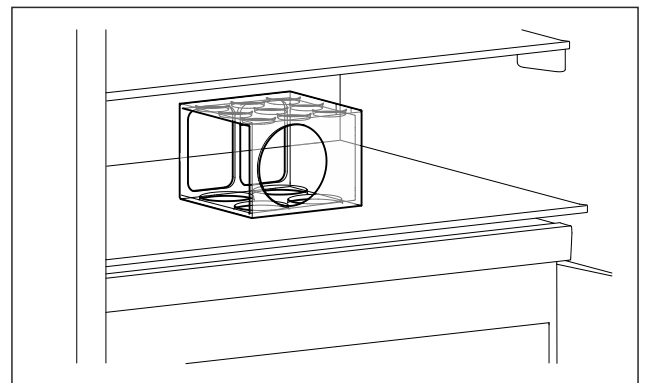

Fig. 158 Example illustration

- ▶ Place FlexCube on shelf.
- ▶ Sort small parts into the FlexCube for storage.

10 Maintenance

10.1 Removing / inserting the bottle holder

10.1.1 Removing the bottle holder

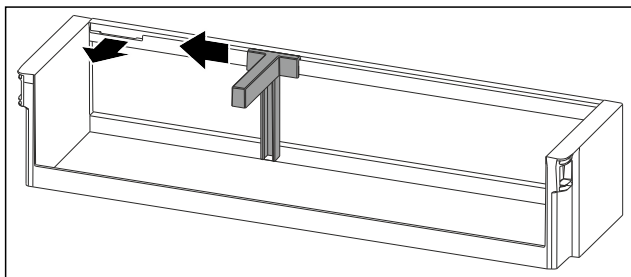

Fig. 159

- ▶ Slide the bottle holder to the side as far as the recess.
- ▶ Remove the bottle holder forwards.

10.1.2 Inserting the bottle holder

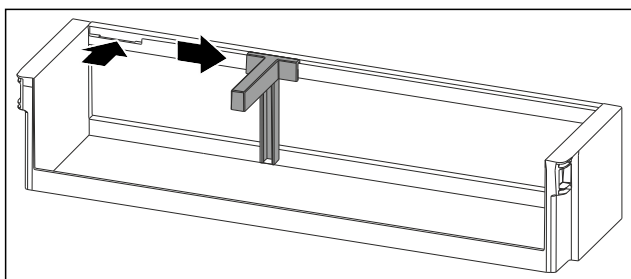

Fig. 160

- ▶ Insert the bottle holder in the recess.
- ▶ Push the bottle holder to the desired position to the side.

10.2 Disassembling / assembling pull-out systems

10.2.1 Notes on disassembly

You can disassemble some of the pull-out systems for cleaning. Your appliance can contain a variety of pull-out systems.

The following pull-out systems can be disassembled or cannot be disassembled:

| | |
|----------------------------------|------------------------------------------------|
| Pull-out system | can be disassembled / cannot be disassembled |
| Fully extendible* | cannot be disassembled* |
| Fridge section partial pull-out* | cannot be disassembled* |
| Telescopic unit | can be disassembled (see 10.2.2 Pull-out unit) |

10.2.2 Pull-out unit

Disassembling pull-out system

Make sure the following prerequisites are met:

- The drawer has been removed. (see 9.5.2 Pull-out unit) (see 9.7 Pull-out unit)

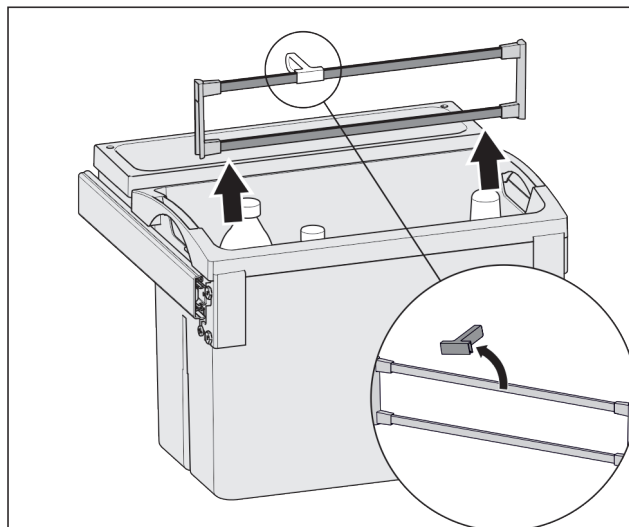
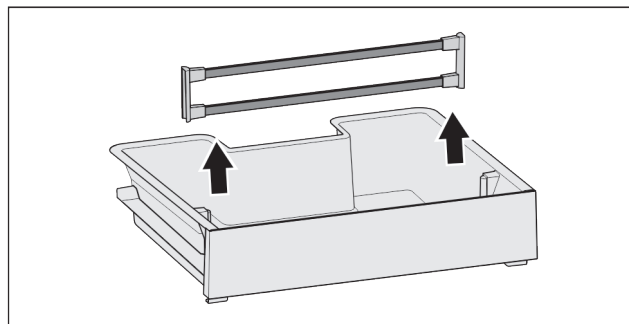

Fig. 161

- ▶ Remove retaining parts as shown in the illustration.

Installing pull-out system

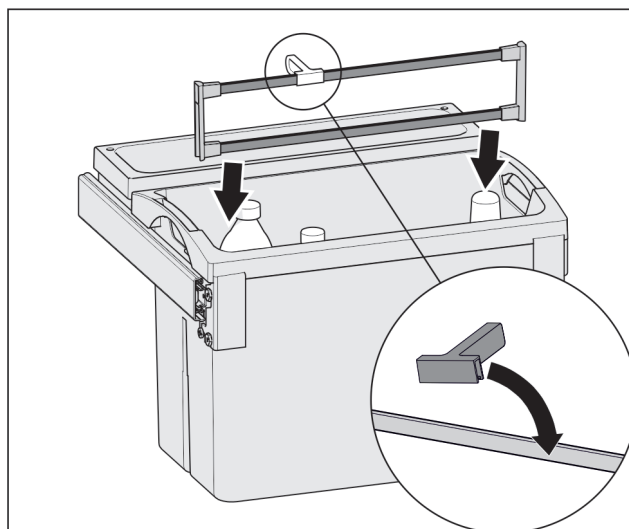
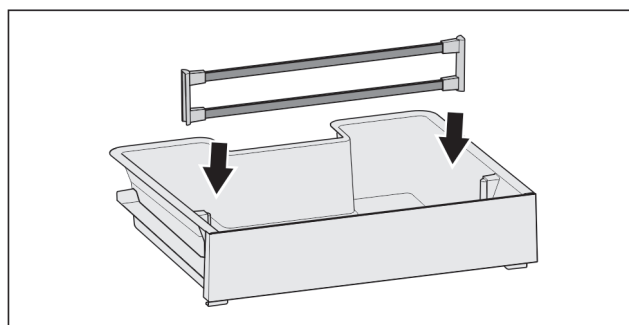

Fig. 162

- ▶ Install retaining parts as shown in the illustration.

Maintenance

10.3 Compartment lid for EasyFresh Safe

You can remove the compartment lid for cleaning.

10.3.1 Removing the compartment lid

Ensure that the following requirements are met:

- ❑ The shelf directly above the drawer has been removed. (see 9.3 Shelves)
- ❑ The drawer directly below the compartment lid has been removed. (see 9.5 Drawers)

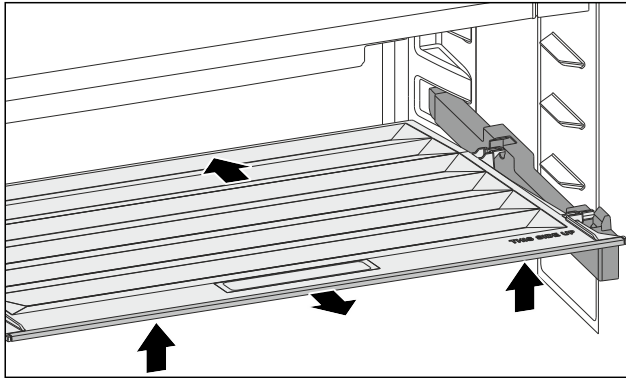

Fig. 163

- ▶ Push the compartment lid backwards.
- ▶ Lift the compartment lid forwards.
- ▶ Remove the compartment lid forwards and upwards at an angle.

10.3.2 Inserting the compartment lid

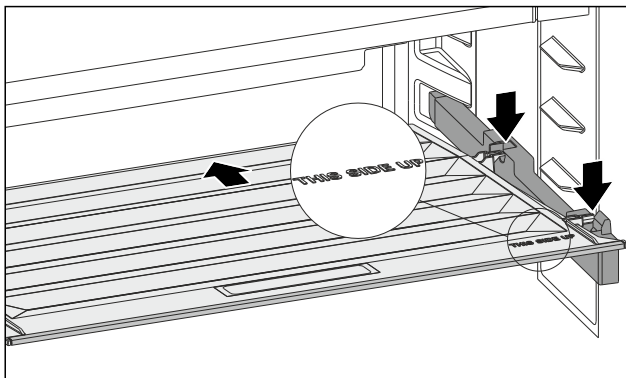

Fig. 164

If the THIS SIDE UP lettering is at the top:

- ▶ Insert the rear retaining parts into the relevant rear openings.
- ▶ Push the compartment lid backwards.
- ▶ Lower the compartment lid forwards and engage the front retaining parts into the openings.
- ▶ Move the compartment lid into the required position.

10.4 Defrosting the appliance



WARNING

Improper defrosting of the appliance!
Injuries and damage.

- ▶ Do not use mechanical equipment or other methods to speed up the defrosting process other than those recommended by the manufacturer.
- ▶ Do not use electrical heating or steam-cleaning appliances, naked flames or defroster sprays to defrost.
- ▶ Do not use sharp objects to remove ice.

10.4.1 Defrosting the fridge compartment

Defrosting is performed automatically. The water from the thawing process drains through the outlet and evaporates. Water drops or a thin layer of frost or ice can form on the back wall; this is a completely normal part of the appliance's function. This must not be removed.

A layer of frost or ice can form briefly due to the energy-optimised control of the device.

- ▶ Clean the drain opening at regular intervals. (see 10.5 Cleaning the appliance)

10.5 Cleaning the appliance

10.5.1 Ready



WARNING

Danger of electric shock!

- ▶ Remove the refrigerator connector or interrupt the power supply.



WARNING

Risk of fire

- ▶ Do not damage the refrigeration circuit.

- ▶ Empty the appliance.
- ▶ Remove mains connector.

-or-

- ▶ Activate CleaningMode. (see CleaningMode)

10.5.2 Cleaning the interior

NOTICE

Improper cleaning!

Damage to the appliance.

- ▶ Only use soft cleaning cloths and ph-neutral all-purpose cleaners.
- ▶ Do not use abrasive sponges or steel wool which may cause scratches.
- ▶ Do not use any sharp or abrasive cleaning agents, nor any that contain sand, chloride or acid.

- ▶ Plastic surfaces: clean by hand with a soft clean cloth, lukewarm water and a little detergent.
- ▶ Metal surfaces: clean by hand with a soft clean cloth, lukewarm water and a little detergent.
- ▶ Drain hole: remove deposits using a thin item (for example a cotton bud).

10.5.3 Clean the components

NOTICE

Improper cleaning!

Damage to the appliance.

- ▶ Only use soft cleaning cloths and ph-neutral all-purpose cleaners.
- ▶ Do not use abrasive sponges or steel wool which may cause scratches.
- ▶ Do not use any sharp or abrasive cleaning agents, nor any that contain sand, chloride or acid.

Clean with a soft, clean cloth, lukewarm water and some detergent:

- Door rack
- Shelf
- Dividing shelf
- Compartment lid for EasyFresh Safe
- Drawer

Clean with a damp cloth:

- Retractable rails
Please note: The grease in the tracks is used for lubrication and must not be removed!

Wash in the dishwasher up to 60 °C:

- Bottle rack
- Holder of the dividing shelf
- FlexCube
- ▶ To disassemble components: see the relevant section.
- ▶ Clean the components.

10.5.4 After cleaning

- ▶ Wipe the appliance and the components dry.
- ▶ Connect and switch on the appliance.
- ▶ Repeat cleaning regularly.

11 Customer help

11.1 Technical specifications

| Temperature range | |
|--------------------|---------------|
| Cooling | 2 °C to 9 °C |
| Larder compartment | 6 °C to 14 °C |

| Maximum ice cube quantity / 24 hours | |
|--------------------------------------|----------------------------------------------------|
| Freezer compartment | see type plate under "Freezing capacity .../ 24 h" |

| Lighting | |
|----------------------------------------------------------------------------|--------------|
| Class ¹ | Light source |
| This product contains one or more energy efficiency class G light sources. | LED |

¹ The appliance may contain light sources with different energy efficiency classes. The lowest energy efficiency class is indicated.

11.2 Operating noises

The appliance makes different noises when it is on.

- At **higher temperatures** the appliance uses less energy but works for longer. It is **quieter**.
- At **lower temperatures** the food is cooled faster. It is **louder**.

Examples:

- Functions on (see 8.2 Appliance functions)
- Food recently added

- High ambient temperature
- Door open for a while

| Noise | Possible cause | Type of noise |
|------------------------|---------------------------------------------------------------------|------------------------|
| Bubbling and splashing | Coolant flowing into the cooling circuit. | Normal operating noise |
| Hissing | Coolant sprays into the cooling circuit. | Normal operating noise |
| Humming | The appliance is cooling. The volume depends on the cooling output. | Normal operating noise |
| Suction noises | Soft-closing door is being opened and closed. | Normal operating noise |
| Clicking | Components are switched on and off. | Normal switching noise |
| Rattling or humming | Valves or flaps are working. | Normal switching noise |

| Noise | Possible cause | Type of noise | Lifting |
|-----------|----------------------------------------|-----------------|----------------------------------------------------------|
| Vibration | Improper installation | Defective noise | Check the installation. Level the appliance. |
| Rattling | Components, items inside the appliance | Defective noise | Secure components. Leave enough space between the items. |

11.3 Technical fault

Your appliance is designed and built to ensure it works reliably and has a long service life. In the unlikely event that a fault occurs during operation, please check whether it is due to an operating error. If so, you will be charged for the callout and repair costs even if it falls within the warranty period.

You can fix the following faults yourself.

11.3.1 Appliance function

| Defect | Cause | Remedy |
|--------------------------------------|-----------------------------------------------------------|--------------------------------------------------------------------------------------------------------------------------------------------|
| The appliance is not working. | → The appliance is not switched on. | ▶ Switch the appliance on. |
| | → The power plug is not properly plugged into the socket. | ▶ Check the power plug. |
| | → There is something wrong with the power outlet fuse. | ▶ Check the fuse. |
| | → Power cut | ▶ Keep the appliance closed. ▶ Safeguarding food: Place cold packs on top of food or use another freezer if the power cut lasts longer. |

Customer help

| Defect | Cause | Remedy |
|-------------------------------------------------------------------------------|-----------------------------------------------------------------------------------------|--------------------------------------------------------------------------------------------------------------------------|
| | | ▶ Do not refreeze defrosted food. |
| | → The IEC socket is not plugged into the appliance correctly. | ▶ Check the IEC socket. |
| Temperature is not cold enough. | → The appliance door is not closed properly. | ▶ Close the appliance door. |
| | → Not enough ventilation. | ▶ Keep ventilation grille clear, and clean it. |
| | → The ambient temperature is too high. | ▶ Problem solution: (see 1.2 Climate classes) |
| | → The appliance was opened too many times or for too long. | ▶ Wait to see if the required temperature corrects itself. If not, contact Customer Service. (see 11.4 Customer Service) |
| | → The temperature is set incorrectly. | ▶ Turn down the temperature and check after 24 hours. |
| | → The appliance is too close to a heat source (oven, radiator, etc). | ▶ Move the appliance or the heat source. |
| | → The appliance was not correctly installed in the recess. | ▶ Check if the appliance was installed correctly and that the door closes properly. |
| The door seal is defective or needs to be replaced for another reason. | → The door seal can be replaced. It can be replaced without the need for special tools. | ▶ Contact Customer Service. (see 11.4 Customer Service) |
| The appliance builds up too much ice or condensation. | → The door seal may have slipped out of its groove. | ▶ Check that the door seal is well fitted in the groove. |

11.3.2 Features

| Defect | Cause | Remedy |
|--------------------------------------------------|-----------------------------------------------------------|----------------------------------------------------------------------------------------------|
| The internal light does not come on. | → The appliance is not switched on. | ▶ Switch the appliance on. |
| | → The door was open for longer than 15 minutes. | ▶ Interior lighting switches off automatically after about 15 minutes when the door is open. |
| | → The LED interior light is faulty or the lid is damaged. | ▶ Contact Customer Service. (see 11.4 Customer Service) |
| The freezer compartment cannot be closed. | → The lock is on when the door is open. | ▶ Use the handle again. |

11.4 Customer Service

First check whether you can rectify the fault yourself (see 11 Customer help) . If you cannot rectify the problem, contact Customer Service.

You can find the address in the enclosed brochure "Liebherr-Service" or at home.liebherr.com/service.



WARNING

Unprofessional repair!
Injuries.

- ▶ Have any repairs and action - not expressly specified - on the appliance and mains cable carried out by service personnel only. (see 10 Maintenance)
- ▶ A damaged mains cable may only be replaced by the manufacturer, the manufacturer's Customer Service or a similarly qualified person.
- ▶ In the case of appliances with an IEC connector, the change may be made by the customer.

11.4.1 Contacting Customer Service

Make sure that the following appliance information is available:

- Appliance name (model and index)

- ❑ Service no. (Service)
- ❑ Serial no. (S no.)
- ▶ Call up the appliance information via the display. (see Device information)

-or-

- ▶ Refer to the type plate for appliance information. (see 11.5 Model plate)
- ▶ Note down the appliance information.
- ▶ Notify customer service: Report errors and the appliance information.
- ▶ This will help us to provide you with a faster, more accurate service.
- ▶ Follow further instructions from Customer Service.

11.5 Model plate

The model plate is behind the drawers on the inside of the appliance.

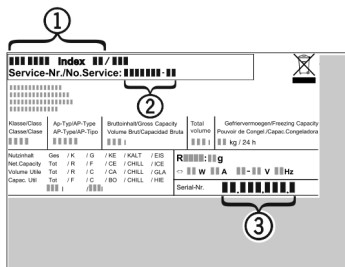

Fig. 165

- (1) Appliance description
- (2) Service no.
- (3) Serial no.

- ▶ Note the data on the model plate.

12 Shutting down

- ▶ Empty the appliance.
- ▶ Switch off appliance. (see Switching the appliance off and on)
- ▶ Pull the mains plug out of the socket.
- ▶ Remove the IEC socket if required: Pull the IEC socket out of the appliance plug and move it to the left and right at the same time.
- ▶ Clean appliance. (see 10.5 Cleaning the appliance)
- ▶ Leave the door open, so that no unpleasant odours arise.

13 Disposal

Ensure that the following requirements are met:

- ❑ Meaning of the symbols on the appliance: are familiar. (see 1.14 Symbols on the appliance)
- ❑ Notes on disposal are familiar. (see 1.8 Disposal)

13.1 Preparing the appliance for disposal

- ▶ Shutting your appliance down. (see 12 Shutting down)

13.2 Disposing of the appliance in an environmentally friendly manner



WARNING

Leaking coolant and oil!

Fire. The coolant contained in the appliance is eco-friendly, but also flammable. The oil contained in the appliance is flammable. Escaping coolant and oil can ignite if the concentration is high enough and in contact with an external heat source.

- ▶ Do not damage the pipelines of the coolant circuit and the compressor.

- ▶ Observe the notes on transporting the appliance. (see 3.5 Transporting the appliance)
- ▶ Remove the appliance without damaging it.
- ▶ Dispose of appliance according to specifications.

Scan QR Code and find
digital operating and
installation instructions.



home.liebherr.com

20260402

7088675-00

Liebherr-Hausgeräte GmbH
Memminger Straße 77-79
88416 Ochsenhausen
Deutschland