

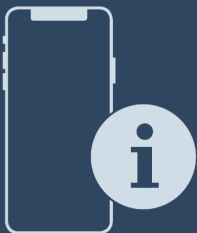

User Guide

Quality, Design and Innovation



home.liebherr.com/fridge-manuals



LIEBHERR

Contents

1	General safety instructions.....	3	7.2.18	LAN connection	41
2	The appliance at a glance.....	5	7.2.19	Appliance information	42
2.1	Included in delivery.....	5	7.2.20	Operating hours	42
2.2	Overview of appliances and equipment.....	5	7.2.21	Software	43
2.3	Special features.....	7	7.2.22	Defrosting	43
2.4	Range of appliance use.....	7	7.2.23	Data download (data backup)	44
2.5	Sound emission of the appliance.....	8	7.2.24	Sensor calibration	44
2.6	Conformity.....	8	7.2.25	Temperature alarm	45
3	Setting up and connecting.....	8	7.2.26	Door alarm	46
3.1	Installation conditions.....	8	7.2.27	Light alarm	47
3.2	Appliance dimensions.....	9	7.2.28	Alarm simulation	47
3.3	Transporting the appliance.....	9	7.2.29	Alarm log	48
3.4	Unpacking the appliance.....	10	7.2.30	Alarm forwarding	49
3.5	Reversing the door opening direction.....	10	7.2.31	Demo mode	49
3.6	Aligning the door.....	21	7.2.32	Resetting to factory settings	50
3.7	Connect power cable.....	21	7.3	Messages.....	50
3.8	Mounting the anti-tipping device.....	21	7.3.1	Warnings.....	50
3.9	Setting up the appliance.....	22	7.3.2	Reminders.....	52
3.10	Setting up multiple appliances.....	22	8	Equipment.....	53
3.11	After setup.....	23	8.1	Safety lock.....	53
3.12	Disposal of packaging.....	23	8.2	Sensors.....	54
3.13	Connecting the appliance to the power supply.....	23	8.3	Sensor info	54
4	Functionality of the Touch & Swipe display.....	24	8.4	Interfaces.....	54
4.1	Navigation and symbol explanation.....	24	9	Maintenance.....	55
4.2	Menus.....	24	9.1	Maintenance schedule.....	55
4.3	Sleep mode.....	25	9.2	Defrosting the appliance.....	57
5	Start-up.....	25	9.3	Cleaning the appliance.....	57
5.1	Switching on the appliance (first use).....	25	9.4	Replacing appliance battery.....	59
5.2	Using equipment.....	26	10	Customer support.....	59
5.3	Center grid shelf.....	27	10.1	Technical data.....	59
6	Storage.....	27	10.2	Technical malfunction.....	60
6.1	Information regarding storing items.....	27	10.3	Data recording.....	61
7	Use.....	27	10.4	Customer Service.....	66
7.1	Control and display elements.....	27	10.5	Type plate.....	66
7.1.1	Status display.....	27	11	Shutting down.....	66
7.1.2	Display symbols.....	27	12	Disposal.....	66
7.1.3	Acoustic signals.....	28	12.1	Preparing the appliance for disposal.....	66
7.2	Appliance functions.....	29	12.2	Disposing of the appliance in an environmentally friendly manner.....	67
7.2.1	Notes on the appliance functions.....	29	13	Additional information.....	67
7.2.2	Switching appliance on and off	29	14	Quick Start Guide for everyday use.....	69
7.2.3	Temperature	29			
7.2.4	Temperature recording	30			
7.2.5	Lighting	30			
7.2.6	Door lock	31			
7.2.7	SmartLock.....	33			
7.2.8	Settings menu access protection	34			
7.2.9	Access codes.....	35			
7.2.10	Maintenance interval reminder	37			
7.2.11	Language	38			
7.2.12	Date and time	38			
7.2.13	Temperature unit	38			
7.2.14	Display Brightness	39			
7.2.15	Alarm tone	39			
7.2.16	Beep	39			
7.2.17	WiFi connection	40			

Congratulations on the purchase of your new appliance. With this purchase, you have chosen all the advantages of the latest refrigeration technology, guaranteeing you a high-quality appliance with a long life span and high operating safety.

The equipment of your appliance gives you the highest level of day-to-day ease of operation.







Together we are making an active contribution to the conservation of our environment by purchasing this appliance which is manufactured in an environmentally friendly process with the use of recyclable materials.

We hope you enjoy your new appliance.

The manufacturer is constantly working to improve all types and models. Therefore, please be aware that we

General safety instructions

reserve the right to make changes to the shape, equipment and technology.

Symbol	Explanation
	Read instructions Please read the information in these instructions carefully to understand all of the benefits of your new appliance.
	Additional information online The digital manual with supplemental information can be found online by scanning the QR code on the front page of this manual or by entering the service number at home.liebherr.com/fridge-manuals .
	Check appliance Check all parts for transport damage. If you have any complaints, please contact your agent or customer service.
	Differences These instructions apply to a range of models, so there may be differences. Sections that apply to certain models only are indicated by an asterisk (*).
	Instructions and results Instructions are marked with a ▶. Results are marked with a ▷.
	Videos Videos about the appliances are available on the YouTube channel of Liebherr-Hausgeräte.

Open-source licenses:

The appliance includes software components that make use of open-source licenses. You can find information on the open-source licenses to be used here: home.liebherr.com/open-source-licenses

These operating instructions apply to:

- SRPvh 1402
- SRPvh 1412
- SRPvh 6501
- SRPvh 6511
- SRPvh 8401
- SRPvh 8411

1 General safety instructions

Please keep these operating instructions in a safe place so you can refer back to them at any time.

If you pass the appliance on, please hand these operating instructions to the new owner.

Read and follow these instructions. They contain safety information which is important for safe and

problem-free installation and operation. Always read and follow the safety information.

Dangers for the user:

- This appliance may only be used by specialist and laboratory personnel who have been trained for this purpose and are familiar with all the safety measures for work in a laboratory. Children and persons with impaired physical, sensory or mental abilities or with a lack of experience and knowledge may not commission or operate this appliance.
- **IMPORTANT:** The power plug must be easily accessible so that the appliance can be disconnected from the mains quickly in an emergency. It must not be behind the back of the appliance.
- Always hold the plug of the cable when disconnecting the appliance from the power supply. Do not pull on the cable.
- Remove the plug or disconnect via the fuse if there is a malfunction.
- **WARNING:** Do not damage the power cable. Do not operate the appliance with a faulty power cable. If the supply cord is damaged, it must be replaced by the manufacturer, its service agent or similarly qualified persons in order to avoid a hazard. For Plug and Play connection cables, the exchange may be carried out by the customer.
- **WARNING:** Multi-sockets/power distributors and other electronic appliances (such as halogen transformers) may not be placed and operated behind appliances.
- **WARNING:** Do not block the ventilation openings in the appliance housing or in the installation housing.
- Repairs and work on the appliance may only be carried out by Customer Service or other specifically trained qualified personnel.
- Always follow the instructions when assembling, connecting and disposing of the appliance.

Risk of fire:

- The refrigerant contained within the appliance (specifications on the type plate) is environmentally friendly, but flammable. Leaking refrigerant can ignite.
 - **WARNING:** Do not damage the refrigerant circuit.
 - Do not handle ignition sources inside the appliance.
 - **WARNING:** Do not use electrical appliances inside the food storage compartments of the appliance, unless they are of the type recommended by the manufacturer.
 - If refrigerant leaks: Remove naked flames or ignition sources located near the area of the leak. Ventilate the room well. Contact Customer Service.
- Do not operate the appliance near explosive gases.
- Do not store or use gasoline or other flammable gases and liquids near the appliance.
- Do not store explosive substances such as aerosol cans with a flammable propellant in this appliance. You can recognize such spray cans by the printed list

General safety instructions

of contents or by a flame symbol. Any leaking gases can be ignited by electrical components.

- Keep lit candles, lamps and other objects with naked flames away from the appliance so they do not cause a fire.
- Alcoholic liquids or other containers holding alcohol must always be tightly sealed for storage purposes. Any leaking alcohol can be ignited by electrical components.

Risk of falling or toppling over:

- **WARNING:** To avoid a hazard due to instability of the appliance, it must be fixed in accordance with the instructions.
- Do not stand on the base, drawers, doors etc. or use them as improper supports.

Danger of frostbite, feeling of numbness and pain:

- Avoid prolonged skin contact with cold surfaces or chilled/frozen food or take protective measures, e.g. wear gloves.

Risk of injury and damage:

- **WARNING:** Do not use mechanical devices or other means to accelerate the defrosting process, other than those recommended by the manufacturer.
- **WARNING:** Risk of injury due to electric shock! There are live electrical parts under the cover. Have the LED interior lighting replaced or repaired only by Customer Service or other suitably trained professionals.
- **NOTICE:** The appliance must only be operated using original manufacturer accessories or accessories from other providers approved by the manufacturer. The user bears the risk of using accessories which are not approved.

Risk of crushing:

- Do not reach into the hinge when opening and closing the door. Fingers may get trapped.

California Proposition 65:

- **WARNING:** This product can expose you to chemicals including Diisononyl Phthalate (DINP), which is known to the State of California to cause cancer, and Diisodecyl Phthalate (DIDP), which is known to the State of California to cause birth defects or other reproductive harm. For more information, go to www.P65Warnings.ca.gov

FCC warning:

- Changes or modifications not expressly approved by the party responsible for compliance could void the user's authority to operate the equipment.

FCC note:

- This appliance has been tested and found to comply with the limits for a Class B digital device, pursuant to part 15 of the FCC Rules. These limits are designed to provide reasonable protection against harmful interference from an installation in residential areas. This appliance generates, uses and can radiate radio-frequency energy and, if not installed

and used in accordance with the instructions, may cause harmful interference to radio communications. However, there is no guarantee that interference will not occur in a particular installation.

If this appliance does cause harmful interference to radio or television reception, which can be determined by switching the appliance on and off, the user should try to correct the interference by one or more of the following measures:

- Reorient or relocate the receiving antenna.
- Increase the distance between the appliance and receiver.
- Connect the appliance to an outlet on a circuit different from that to which the receiver is connected.
- Consult the dealer or an experienced radio/TV technician for help.

FCC Radio Frequency Exposure Statement:

- This appliance is found to comply with FCC radio frequency (RF) exposure limits set for an uncontrolled environment. This transmitter must not be set up or operated in conjunction with another antenna or another transmitter.
- This appliance should be installed and operated at a minimum separation distance of 20 cm between the antenna and your body. The user must follow the specific operating instructions to comply with the limits of RF exposure.

IC note:

- This appliance has license-exempt transmitters/receivers, which comply with the license-exempt Radio Standards Specification (RSS) of Innovation, Science and Economic Development Canada.

Operation is subject to the following two conditions:

- This appliance may not cause interference.
- This appliance must accept any interference, including interference that may cause undesired operation of the appliance.

IC Radio Frequency Exposure Statement:

- This appliance is found to comply with IC RSS-102 radio frequency (RF) exposure limits set for an uncontrolled environment. This appliance should be installed and operated at a minimum separation distance of 20 cm between the antenna and your body.

Specialist personnel qualifications:

The appliance may only be installed, tested, maintained, and commissioned by specialist personnel who are familiar with the installation, commissioning, and operation of the appliance. Specialist personnel are persons who, on account of their specialist training, knowledge and experience as well as their knowledge of the relevant standards, are able to assess and perform the work assigned to them and identify potential hazards. They must have

training, instruction, and authorization to work on the appliance.

Symbols on the device:



The symbol may be located on the compressor. It refers to the oil in the compressor and refers to the following danger: **Can be fatal if swallowed or inhaled.** This notice only applies for recycling. There is no danger during normal operation.



WARNING: Risk of fire / flammable materials. The symbol is located on the compressor and indicates the danger from flammable materials. Do not remove the label.



The symbol is located on the back of the appliance near the alarm relay and indicates the following danger: **Electric shock!** Even if an appliance is disconnected from the mains there may still be extraneous voltage. Do not remove the label.



This label or a similar one may be located on the rear of the appliance. This label indicates that there are vacuum insulation panels (VIP) or perlite panels in the door and/or housing. This notice only applies for recycling. Do not remove the label.

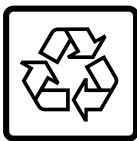

Li-ion

This label or a similar one may be located on the rear of the appliance. It refers to the Li-ion battery installed. This notice only applies for recycling. Do not remove the label.

Observe the warning messages and other detailed information in the other sections:

	DANGER	Indicates an immediately hazardous situation, which if not avoided, will result in death or serious injury.
	WARNING	Indicates a hazardous situation, which if not avoided, could result in death or serious injury.
	CAUTION	Indicates a hazardous situation, which if not avoided, could result in minor or moderate injury.
	NOTICE	Indicates a hazardous situation, which if not avoided, could result in damage to property.
	Note	Indicates useful advice and tips.

2 The appliance at a glance

2.1 Included in delivery

Check all parts for transport damage. If you have any issues, please contact your dealer or Customer Service. (see 10.4 Customer Service)

The delivery contains the following parts:

- Freestanding appliance
- Equipment *
- Installation materials *
- Operating instructions
- Warranty documents
- Quality certificate *
- Power cable
- Emergency unlocking key
- Wall fastening kit
- Closure plug (to close the drain opening for cleaning water)

2.2 Overview of appliances and equipment

SRPvh 6501
SRPvh 8401

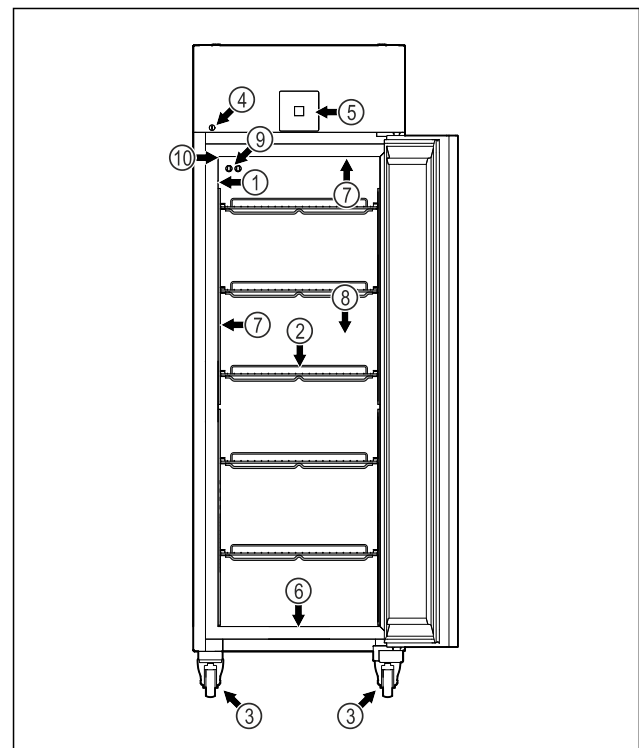

Fig. 1 Example illustration

- (1) Type plate
- (2) Grid shelves
- (3) Casters
- (4) Top panel
- (5) Control panel
- (6) Drain hole for water from cleaning
- (7) Interior lighting *
- (8) Safety thermostat sensor

The appliance at a glance

- (4) Lock
- (5) Control elements and temperature display
- (9) P Sensor
- (10) Sensor feedthrough

SRPvh 6511
SRPvh 8411

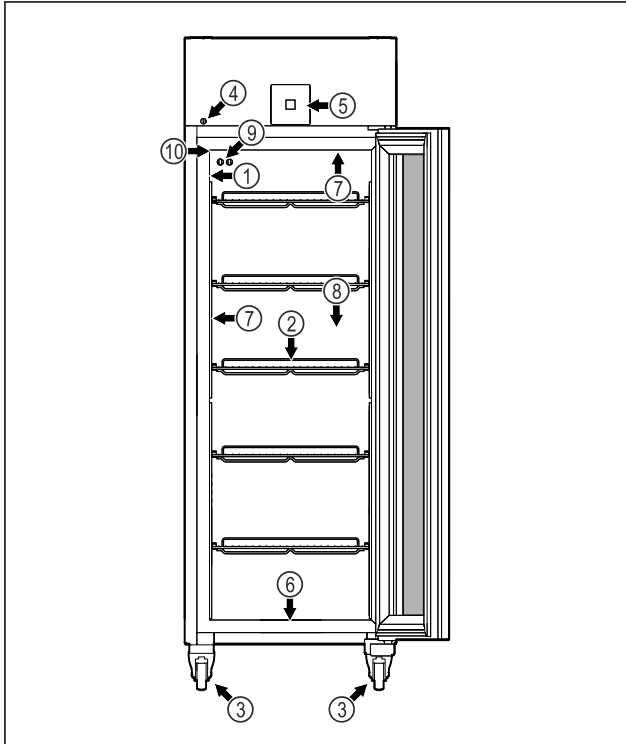

Fig. 2 Example illustration

- (1) Type plate
- (2) Grid shelves
- (3) Casters
- (4) Lock
- (5) Control elements and temperature display
- (6) Drain hole for water from cleaning
- (7) Interior lighting *
- (8) Safety thermostat sensor
- (9) P Sensor
- (10) Sensor feedthrough

SRPvh 1402

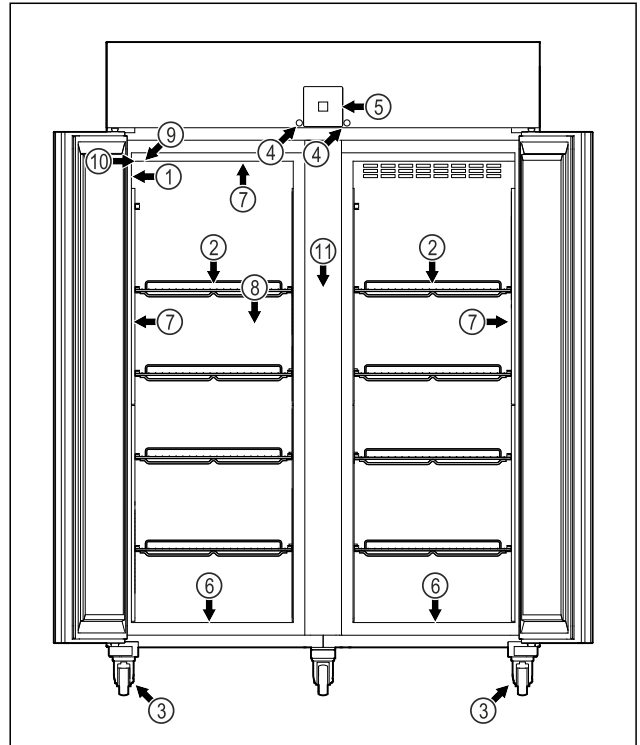

Fig. 3 Example illustration

- (1) Type plate
- (2) Grid shelves
- (3) Casters
- (4) Lock
- (5) Control elements and temperature display
- (6) Drain hole for water from cleaning
- (7) Interior lighting *
- (8) Safety thermostat sensor
- (9) P Sensor
- (10) Sensor feedthrough
- (11) Center grid shelf

SRPvh 1412

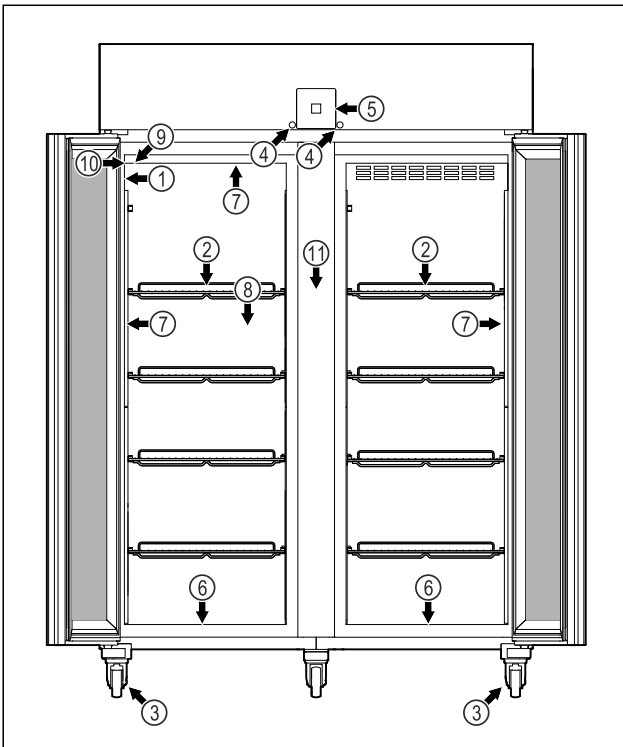

Fig. 4 Example illustration

- | | |
|--|------------------------------|
| (1) Type plate | (7) Interior lighting * |
| (2) Grid shelves | (8) Safety thermostat sensor |
| (3) Casters | (9) P Sensor |
| (4) Lock | (10) Sensor feedthrough |
| (5) Control elements and temperature display | (11) Center grid shelf |
| (6) Drain hole for water from cleaning | |

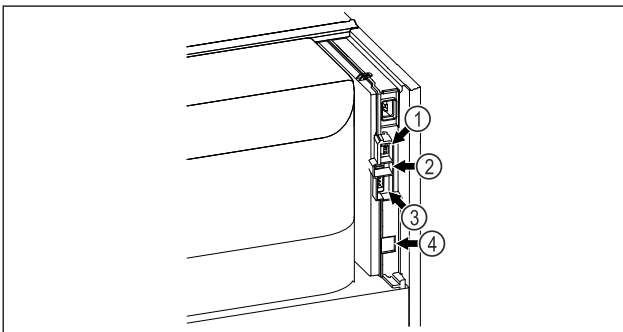

Fig. 5 Example illustration

- | | |
|-----------------------------|---------------------------------|
| (1) Connection for P sensor | (3) Potential-free alarm output |
| (2) USB interface | (4) LAN interface |

2.3 Special features

Note

Accessories are available from the Liebherr Service Center. The address for your respective country can be found on the back of the instructions.

SmartModule

The appliance is equipped with a SmartModule.

This is a WLAN and LAN interface for the connection between the appliance and an external documentation and alarm system, such as the Liebherr SmartMonitoring dashboard, for example.

The Liebherr SmartMonitoring dashboard is not available in all countries. Check for availability via the QR code (see 7.2.17 WiFi connection) and entering your model.

Retrofitting drawers

Temperature qualification is required when retrofitting drawer systems in Liebherr refrigerators/freezers where these are used for temperature-sensitive materials such as chilled drugs and refrigerated products that are subject to specific standard requirements. Retrofitting drawers in Liebherr refrigerators/freezers can result in the goods stored becoming spoiled or damaged. The retrofitting must therefore be completed exclusively by authorized service providers from the manufacturer of the refrigerator/freezer.

2.4 Range of appliance use

Intended use

This laboratory refrigerator is suitable for the professional storage of products at temperatures between:

- **Foamed door:** -2 °C (28 °F) and 16 °C (60 °F).*
- **Glass door:** 0 °C (32 °F) and 16 °C (60 °F).*

Typical products to be stored include research samples, reagents, laboratory inventory etc.

The appliance meets the requirements of DIN 13277 – Refrigerators and freezers for laboratory and medical applications.

Storage of temperature-sensitive substances requires the use of an independent, permanently monitored alarm system. This alarm system must be designed such that a responsible person can record every alarm condition to be able to take suitable measures.

Foreseeable incorrect use

Do not use the appliance for the following applications:

- Storage and cooling of:
 - Chemically unstable, flammable or corrosive substances
 - Blood, plasma or other body fluids for the purpose of infusion, application or introduction in the human body.
- Use in potentially explosive atmospheres.
- Use outdoors or in areas exposed to dampness and splashing water.
- Used in a residential spaces because suitable protection of radio reception cannot be ensured in these environments.*

Setting up and connecting

Any misuse of the appliance may result in damage to or spoilage of stored goods.

Climate classes

The climate class for your appliance is printed on the identification plate.

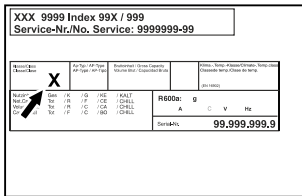

Fig. 6 Type plate

(X) This climate class indicates the environmental conditions in which the appliance can be operated safely.

Climate class (X)	max. room temperature	max. rel. humidity
7	35 °C (95 °F)	75%

Note

The minimum permitted room temperature at the setup location is 10 °C (50 °F).

The interior temperature of the appliance never exceeds the ambient temperature at the setup location.

In the case of boundary conditions, slight condensate may form on the glass door (depending on the equipment) and on the side walls.

2.5 Sound emission of the appliance

The A-weighted emission sound pressure level during operation of the appliance is below 70 dB(A) (sound power rel.1 pW).

2.6 Conformity

The refrigerant circuit has been tested for leaks. The appliance complies with the relevant safety regulations as well as the corresponding directives.

3 Setting up and connecting

3.1 Installation conditions

The installation conditions are crucial to ensure that you can operate your appliance safely, efficiently, and trouble-free.

- Observe all safety instructions.
- Observe the installation location and position in the room.



WARNING

Danger of fire due to incorrect positioning!

If the power supply cable or plug touches the back of the appliance, the vibration can damage the power supply cable or the plug resulting in a short circuit.

- ▶ Make sure the power supply cable is not trapped under the appliance when you position the appliance.
- ▶ Install the appliance so that it does not touch any plugs or power cables.
- ▶ Do not connect any appliances to sockets in the area of the back of the appliance.
- ▶ Do **not** place and operate power strips/power distributors and other electronic devices (such as halogen transformers) at the back of the appliances.



WARNING

Risk of fire due to moisture!

If live parts or the power cord get wet, this can cause a short circuit.

- ▶ The appliance is designed for use in enclosed spaces. Do not operate the appliance in open space or in damp areas or where there is spray.



WARNING

Leaking refrigerant and oil!

Fire. The refrigerant contained within the appliance is environmentally friendly, but flammable. The oil contained within the appliance is flammable. Escaping refrigerant and oil can ignite if they are of high enough concentration and are exposed to an external heat source.

- ▶ Do not damage the pipelines of the coolant circuit and the compressor.

3.1.1 Installation location

- The optimum installation location is a dry and well-ventilated space.
- If the appliance is set up in a very humid environment, condensation may form on the outside of it. Always ensure good ventilation at the installation location.
- The more refrigerant there is in the appliance, the larger the room in which the appliance is installed must be. If the room is too small, a flammable gas/air mixture may form in the event of a leak. Per 8 g (0.28 oz) refrigerant, the installation space must be at least 1 m³ (35.5 ft³) in size. Information on the refrigerant contained can be found on the type plate inside the appliance.
- The floor at the installation location must be horizontal and level.
- The installation location must be able to support the weight of the appliance, including its maximum storage capacity. (see 10.1 Technical data)

3.1.2 Position in the space

- Do not set up the appliance in an area with direct sunlight, next to a heating unit or similar.
- Always place the rear of the appliance directly against the wall.
- Use in potentially explosive atmospheres is not permitted.

3.2 Appliance dimensions

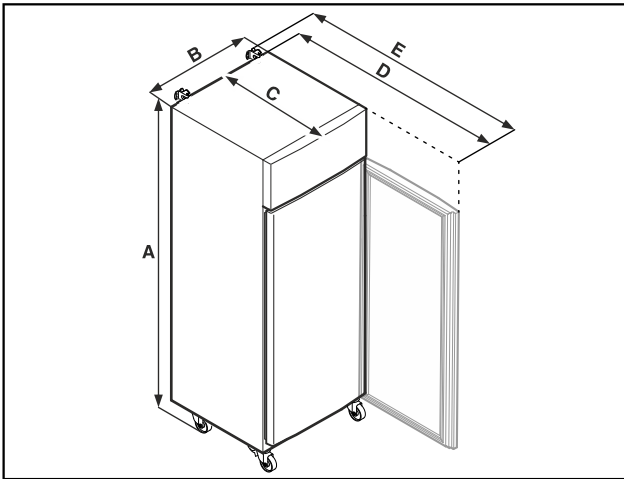

Fig. 7 Example illustration

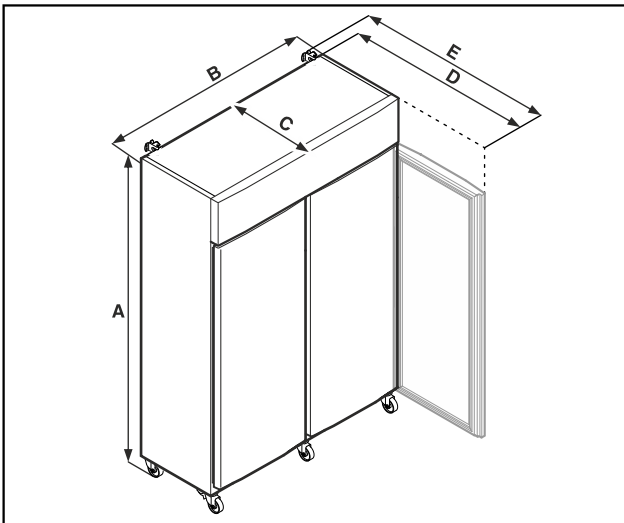

Fig. 8 Example illustration

	SRPvh 8401 SRPvh 8411
A	2135 mm (84 1/16 in)
B	787 mm (31 in)
C	1017 mm (40 1/16 in)
D	1740 mm (68 1/2 in)
E	1772 mm (69 13/16 in)

A = appliance height including feet (minimum) / casters

B = appliance width without handle

C = appliance depth without handle

D = appliance depth with door open

F = appliance depth with protruding handle and anti-tipping device

3.3 Transporting the appliance



WARNING

There is a risk of injury from pieces of broken glass.* When transporting at an altitude of more than 1500 m (4,921.26 ft), the glass panes of the door may break. This can result in sharp-edged fragments, which can cause serious injuries.

- ▶ Adopt suitable protective measures.



DANGER

Danger of injury and damage due to a heavy appliance!

- ▶ At least two persons are required to transport the appliance.



DANGER

Danger of injury and damage due the equipment falling over!

- ▶ Pay attention to the evenness of the ground and ramps when transporting the equipment.

3.3.1 Transporting the appliance for initial installation

Make sure that the following requirements are fulfilled:

- The appliance is upright.
- If necessary: The two-door appliance is dismantled for transport.
- ▶ Transport the appliance with at least two persons.

	SRPvh 1402 SRPvh 1412	SRPvh 6501 SRPvh 6511
A	2135 mm (84 1/16 in)	2135 mm (84 1/16 in)
B	1427 mm (56 3/16 in)	697 mm (27 7/16 in)
C	867 mm (34 2/16 in)	867 mm (34 2/16 in)
D	1500 mm (59 1/16 in)	1500 mm (59 1/16 in)
E	1532 mm (60 5/16 in)	1532 mm (60 5/16 in)

Setting up and connecting

3.3.2 Transporting the appliance after initial installation

Observe the following instructions if you want to transport or move the appliance after initial installation.

Make sure that the following requirements are fulfilled:

- ❑ Appliance is empty.
- ❑ The appliance is upright.
- ❑ Appliance with door(s): The door is secured against undesired opening.
- ❑ Appliance with pull-out cart: The pull-out cart is secured against undesired opening.
- ❑ Appliance with adjustable feet: Adjustable feet are turned in.
- ▶ If necessary: Disassemble and transport the appliance in the same way as for initial installation. (see 3.3.1 Transporting the appliance for initial installation)

After transporting it:

- ▶ Align the appliance.

3.4 Unpacking the appliance

- ▶ Check the appliance and the packaging for transport damage. Contact the supplier immediately if you suspect any damage. Do not connect the appliance to the power supply.
- ▶ Remove all packaging materials from the rear or the side walls of the fridge that may prevent proper installation or prevent air flow and ventilation.

3.5 Reversing the door opening direction

3.5.1 Safety notes



WARNING

Risk of injury if the door is not reversed correctly!

- ▶ Have a specialist change the door hinge.



WARNING

Risk of injury and material damage due to heavy door!

- ▶ Only perform the conversion if you can carry a weight of 45 kg (99.21 lb).
- ▶ Always have someone help you carry out the conversion.

NOTICE

Live parts!

Damage to electrical components.

- ▶ Pull the power plug before changing the door hinges.

3.5.2 Tools



3.5.3 Opening the aggregate cover

- ▶ Open the door.

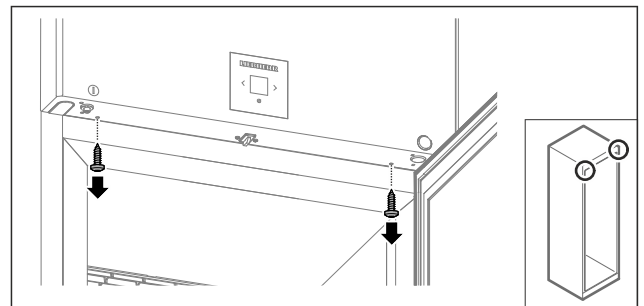

Fig. 9

- ▶ Remove the screws.

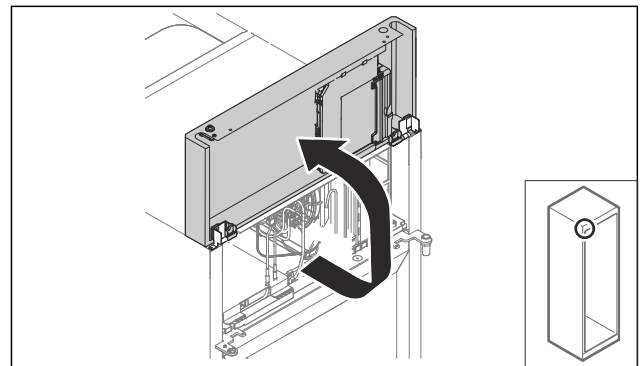

Fig. 10

- ▶ Lift the aggregate cover.
- ▶ Hold on to the cover.

-or-

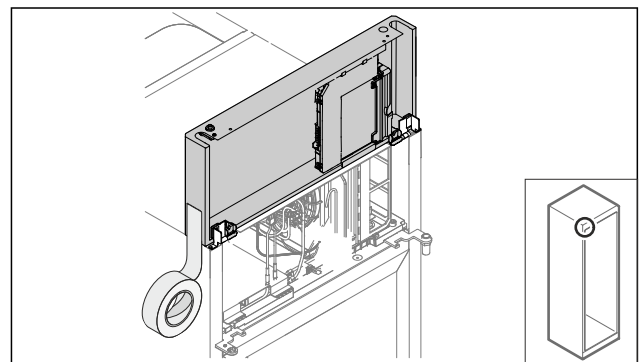

Fig. 11

- Fix the cover.

3.5.4 Removing the door

3.5.4 Removing the door (glass door)*

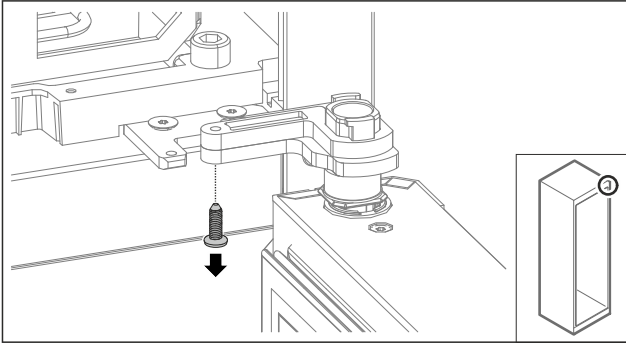

Fig. 12

- Remove the screw.

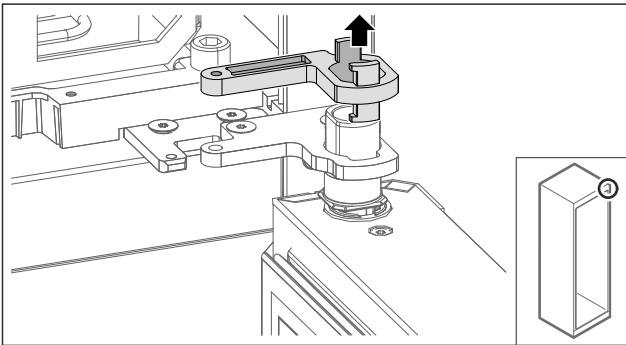

Fig. 13

- Remove the swap bearing block lock.

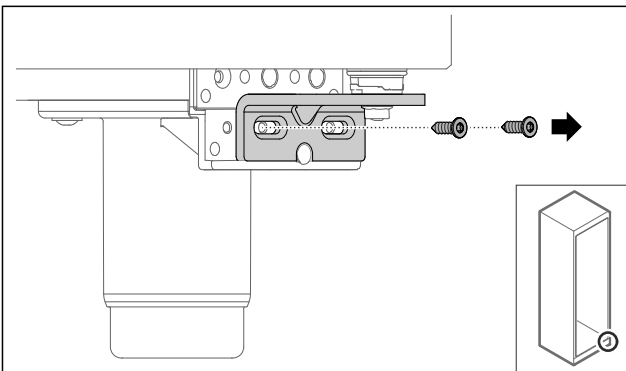

Fig. 14

- Remove the screws.

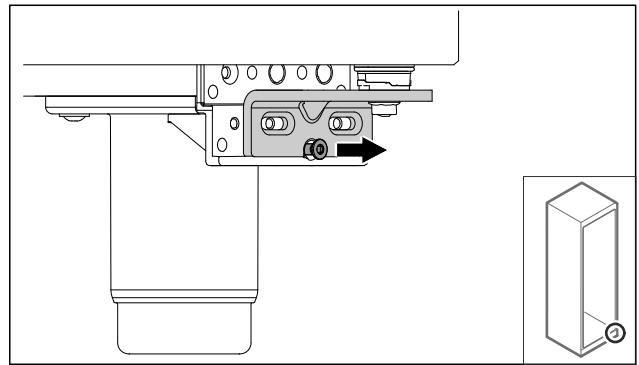

Fig. 15

- Loosen the screw.

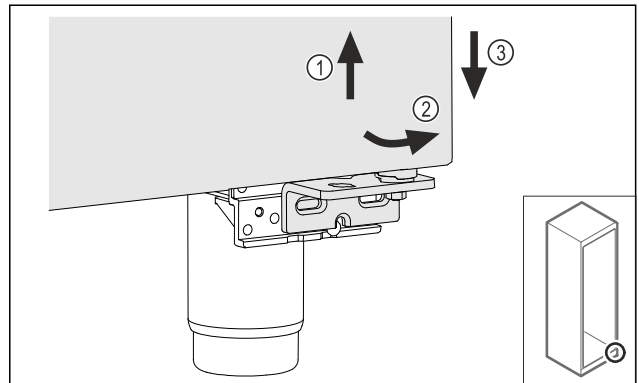

Fig. 16

- Lift the door slightly Fig. 16 (1), tip it forward Fig. 16 (2) and lower it Fig. 16 (3).
- Place the door on a soft support.
- The glass door is removed.

3.5.4 Removing the door (foamed door)*

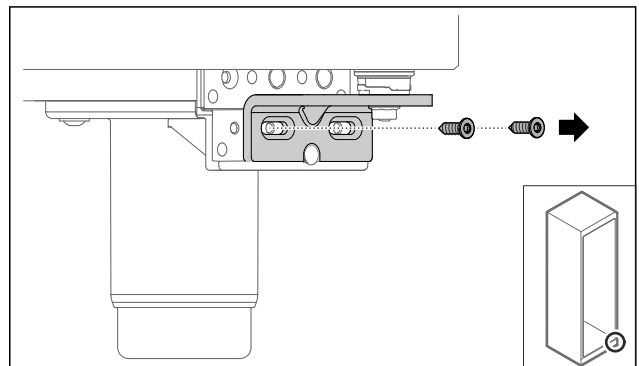

Fig. 17

- Remove the screws.

Setting up and connecting

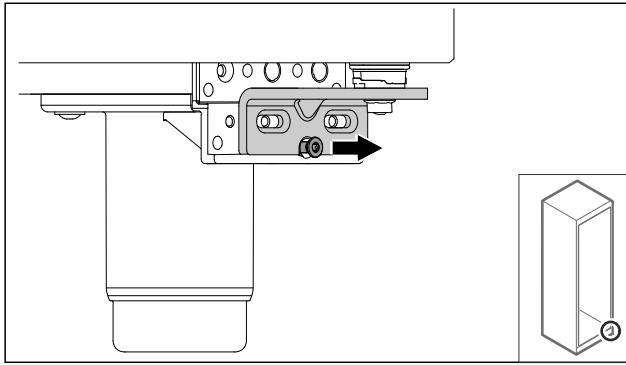

Fig. 18

- ▶ Loosen the screw.

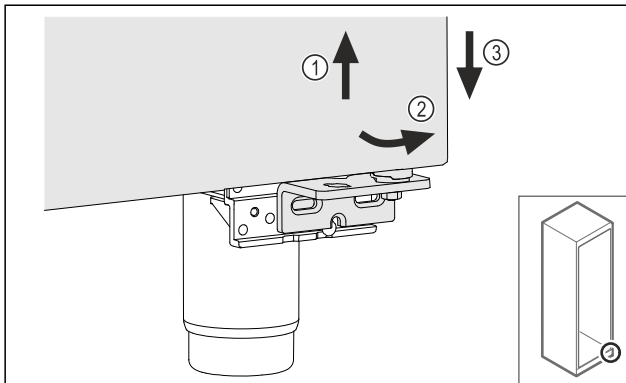

Fig. 19

- ▶ Lift the door slightly Fig. 19 (1), tip it forward Fig. 19 (2) and lower it Fig. 19 (3).
- ▶ Place the door on a soft support.
- ▶ The foamed door has been removed.

3.5.5 Changing the lower locking system

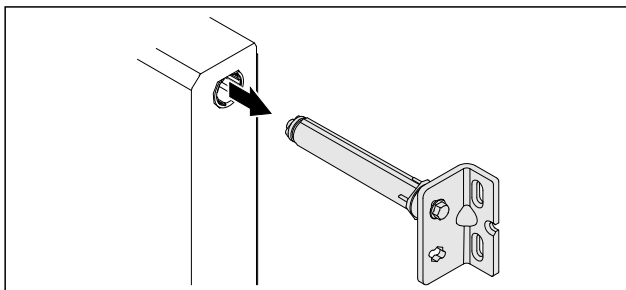

Fig. 20

- ▶ Pull the lower hinge angle bracket out of the door.

NOTICE

Danger of injury due to tensioned spring!

- ▶ Do not dismantle the door locking system Fig. 21 (1).

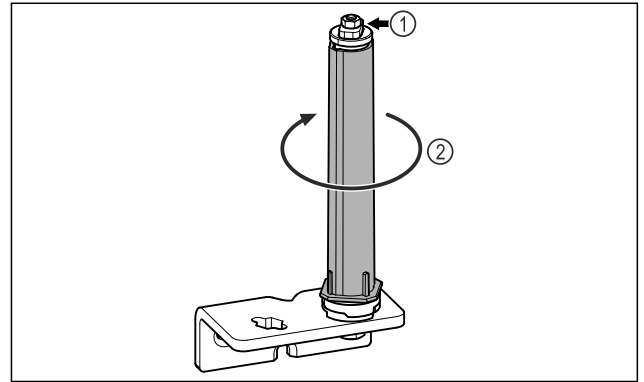

Fig. 21

- ▶ Turn the locking system Fig. 21 (2) until it clicks.
- ▶ The locking system pretension is released.

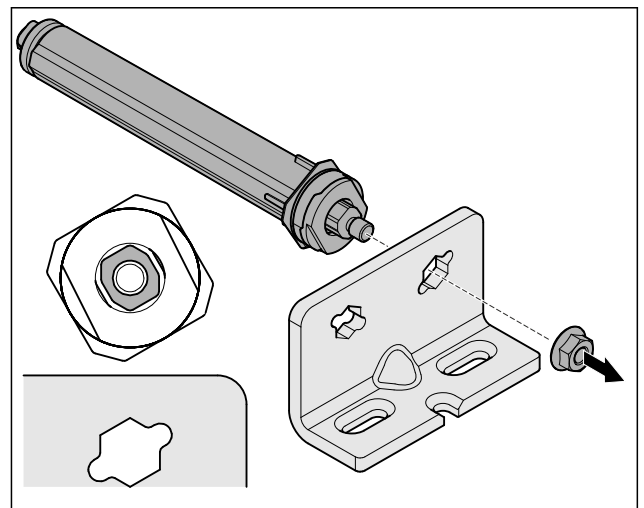

Fig. 22 Right-hinged

- ▶ Loosen nut.

Note

Incorrect alignment of the height adjustment washers. Nuts no longer have sufficient hold.

- ▶ The washer must lock into the underside of the closing system.

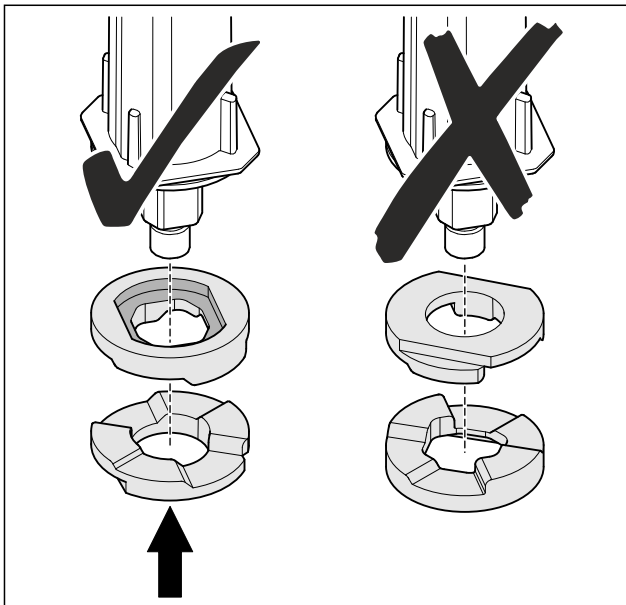

Fig. 23

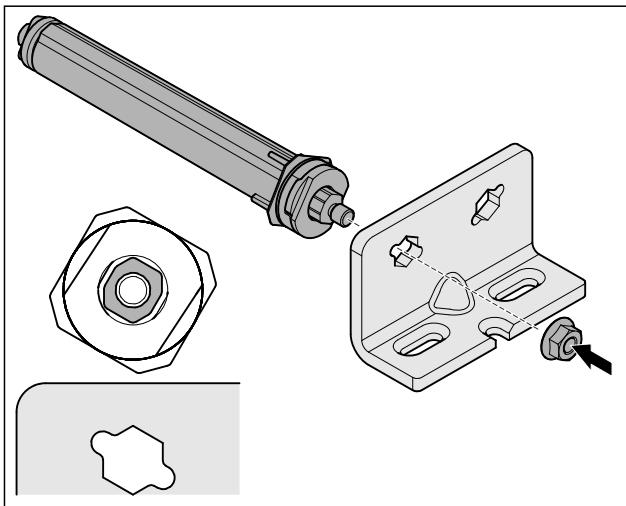

Fig. 24 Left-hinged

- ▶ Change over the closing system and tighten; observe the alignment of the closing system.
- ▶ The lower locking system has been changed.

3.5.6 Changing the upper locking system

3.5.6 Changing the upper locking system (glass door)*

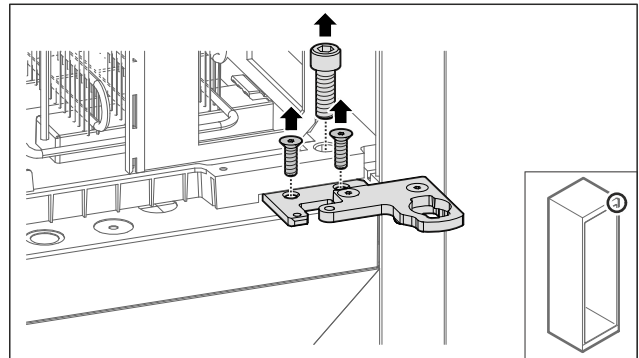

Fig. 25

- ▶ Remove the screws.

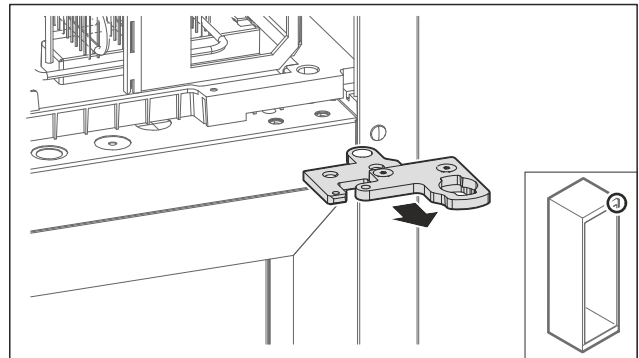

Fig. 26

- ▶ Remove the two-part hinge angle bracket.

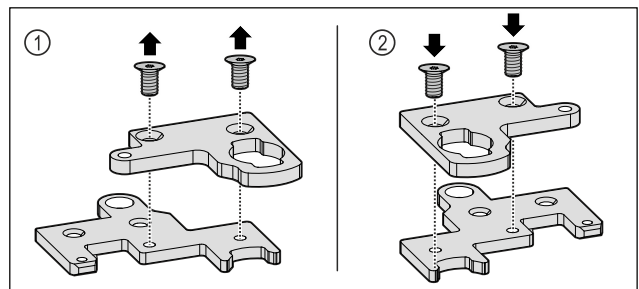

Fig. 27

- ▶ Disassemble the two-part hinge angle bracket.

Fig. 27 (1)

- ▶ Turn the two-part hinge angle bracket 180° (180°) and then reassemble it. Fig. 27 (2)

Setting up and connecting

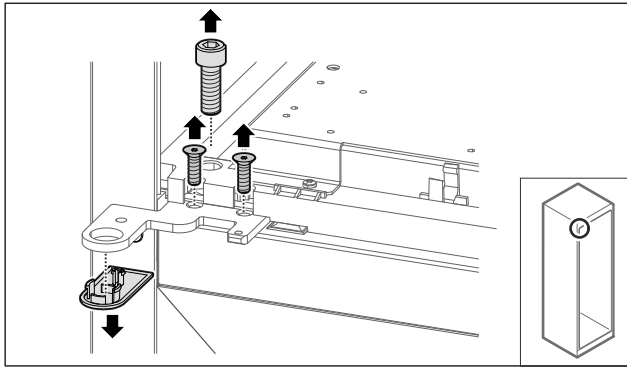

Fig. 28

- ▶ Remove the screws and cover.

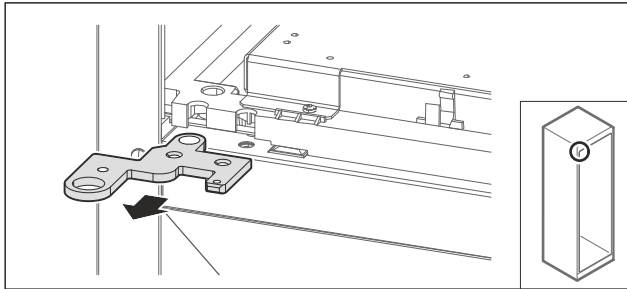

Fig. 29

- ▶ Remove the hinge angle bracket.

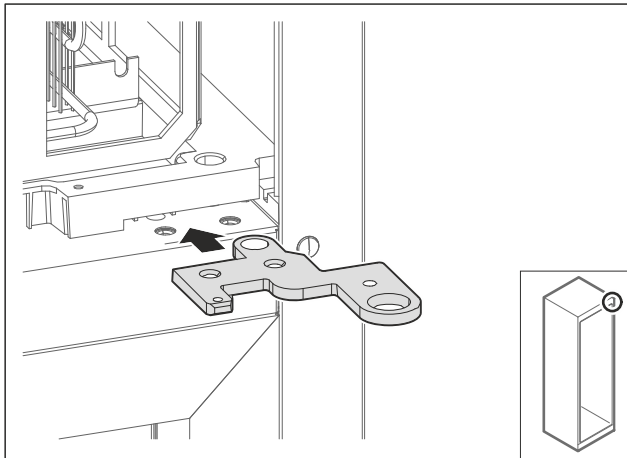

Fig. 30

- ▶ Turn the hinge angle bracket 180° (180°) and move it to the opposite side.

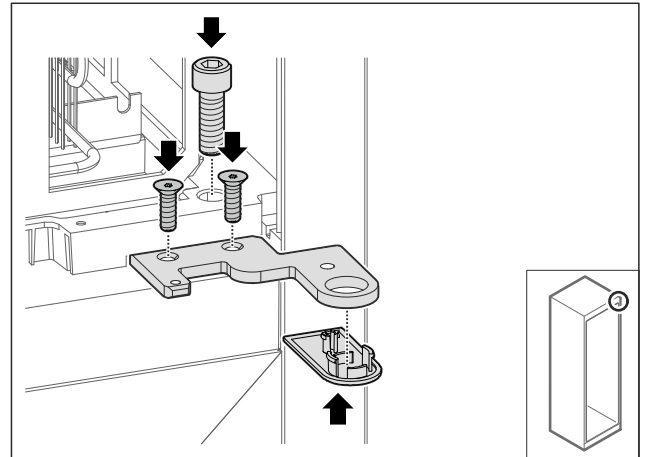

Fig. 31

- ▶ Tighten the hinge angle bracket.
- ▶ Put on the cover.

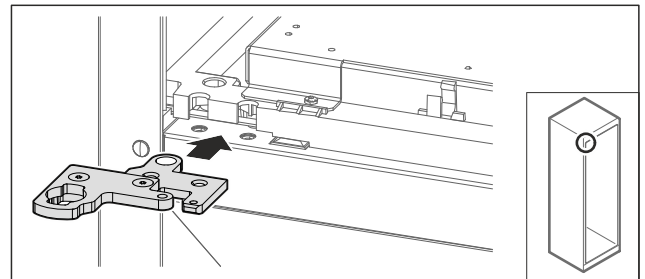

Fig. 32

- ▶ Move the two-part hinge angle bracket to the opposite side.

Note

Do not pinch the cable.

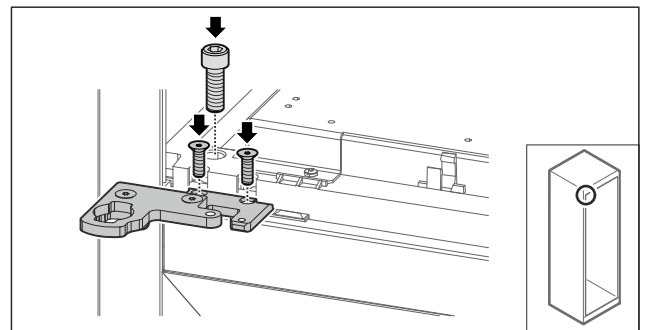

Fig. 33

- ▶ Tighten the two-part hinge angle bracket.
- ▶ The upper locking system has been changed.

3.5.6 Changing the upper locking system (foamed door)*

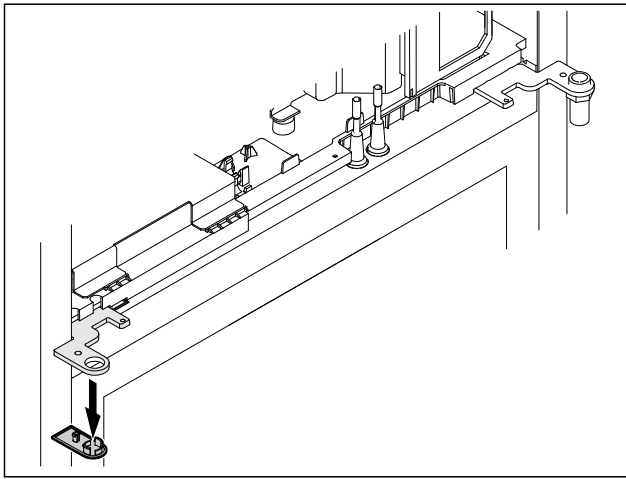

Fig. 34

- ▶ Remove the cover.

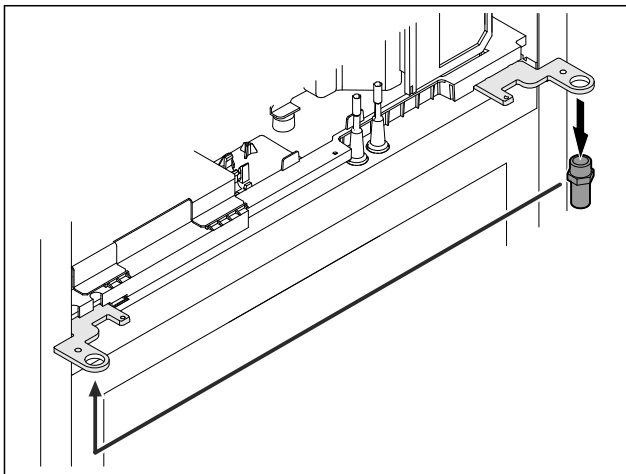

Fig. 35

- ▶ Move the pin in the hinge angle bracket.
- ▶ Tighten the pin with a **tightening torque of 12 Nm (9 ft-lb)**.

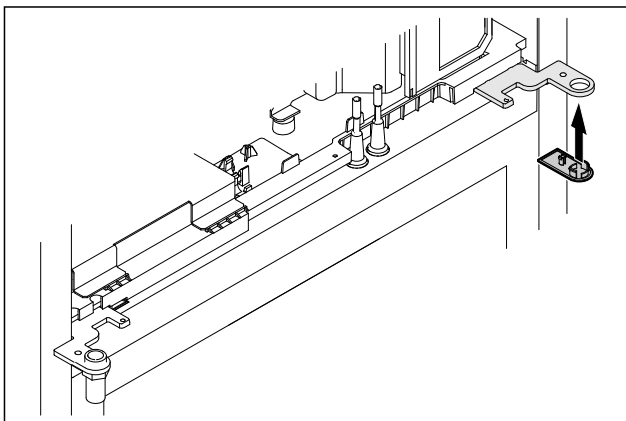

Fig. 36

- ▶ Put on the cover.
- ▶ The upper locking system has been changed.

3.5.7 Changing over the lock

3.5.7 Moving the lock (electronic lock)

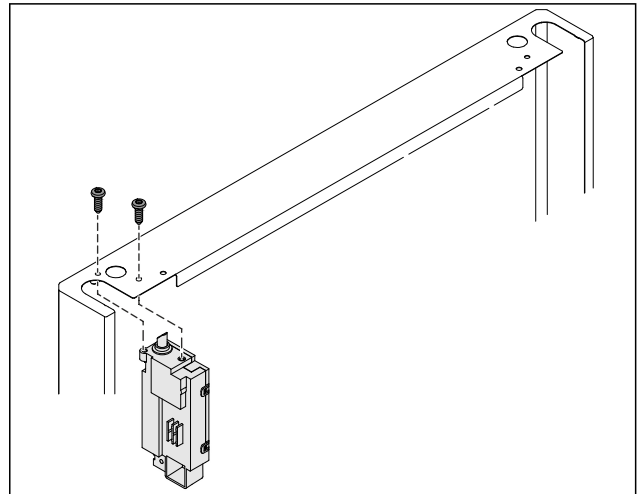

Fig. 37

- ▶ Remove the screws and remove the lock.
- ▶ The connected cable remains in the lock. Loosen any fasteners.

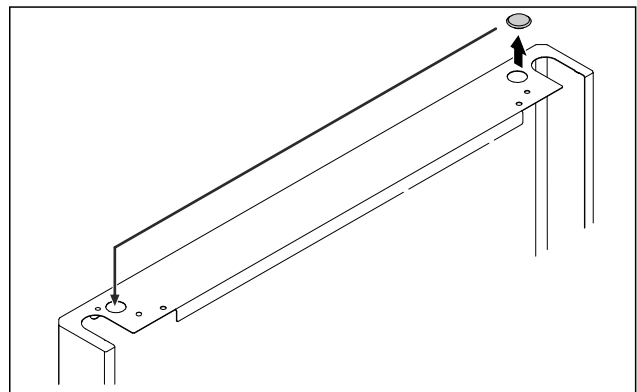

Fig. 38

- ▶ Swap the cover to the opposite side.

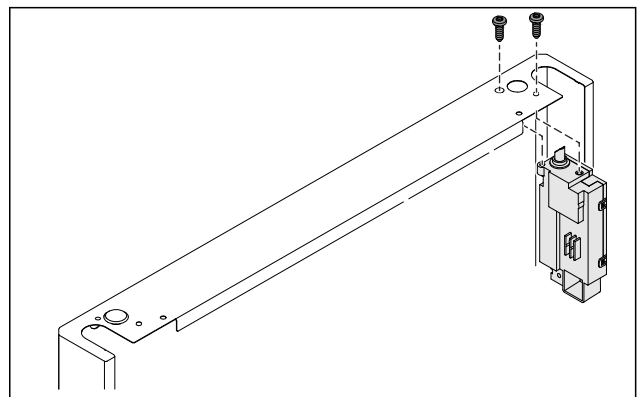

Fig. 39

- ▶ Insert the lock and screw in place.
- ▶ The electronic lock is moved.

Setting up and connecting

3.5.8 Moving the swap bearing block

3.5.8 Moving the swap bearing block (rollers)



WARNING

Danger of injury and damage due to appliance tipping over!

Danger to life and material damage to appliance. If you remove the casters from the appliance, the appliance can tip over.

- ▶ Before performing a conversion on the appliance: Prevent appliance from tipping over.

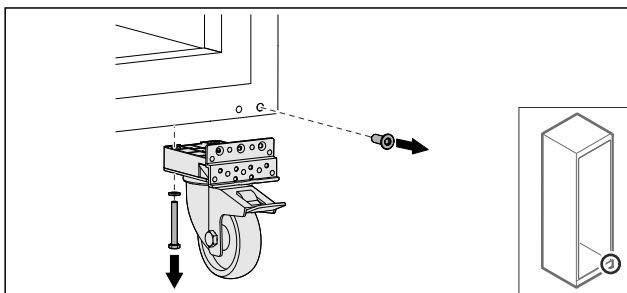

Fig. 40

- ▶ Unscrew and remove casters.

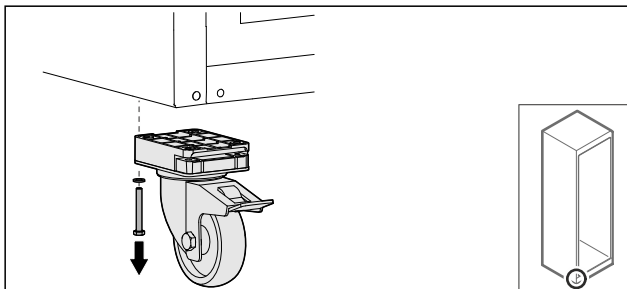

Fig. 41

- ▶ Unscrew and remove casters with bearing bracket.

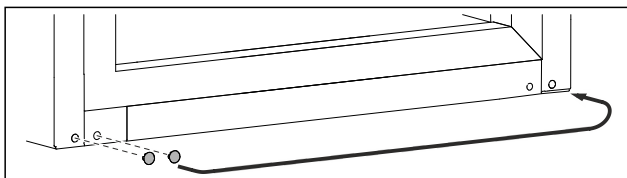

Fig. 42

- ▶ Swap over covers.

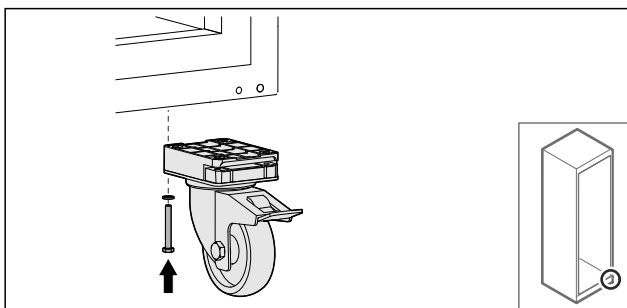

Fig. 43

- ▶ Screw on casters.

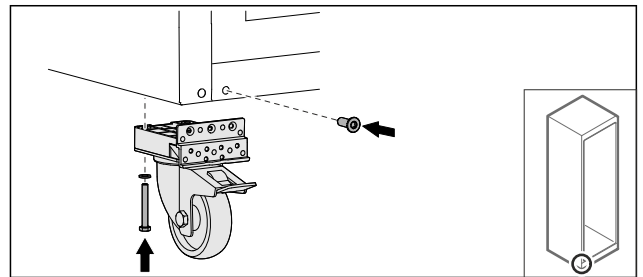

Fig. 44

- ▶ Screw on casters with bearing bracket.
- ▶ The swap bearing block is moved.

3.5.9 Changing the door

3.5.9 Changing the door (glass door)*

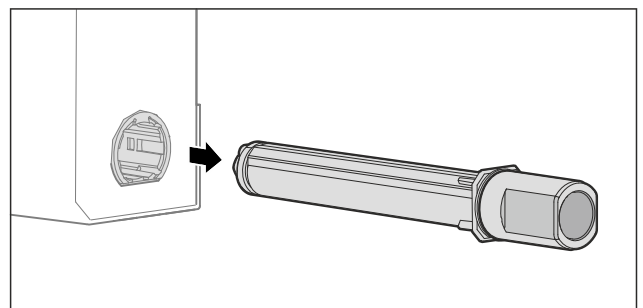

Fig. 45

- ▶ Pull the upper locking system out of the door.

NOTICE

Danger of injury due to tensioned spring!

- ▶ Do not dismantle the door locking system Fig. 46 (1).

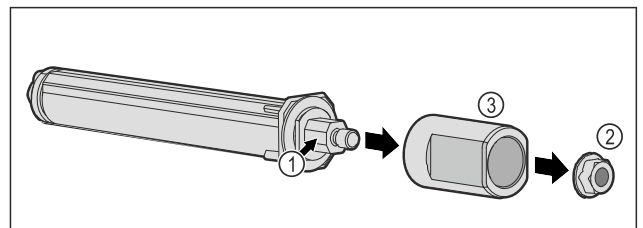

Fig. 46

- ▶ Remove the nut Fig. 46 (2).
- ▶ Remove the sleeve Fig. 46 (3).

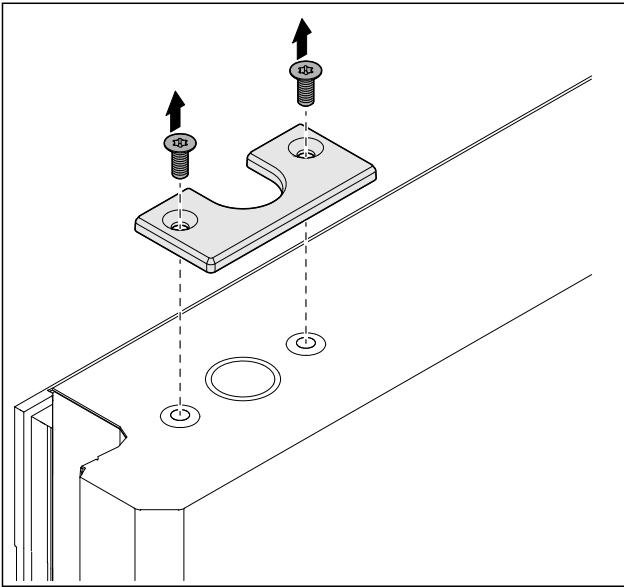

Fig. 47

- Unscrew the cover.

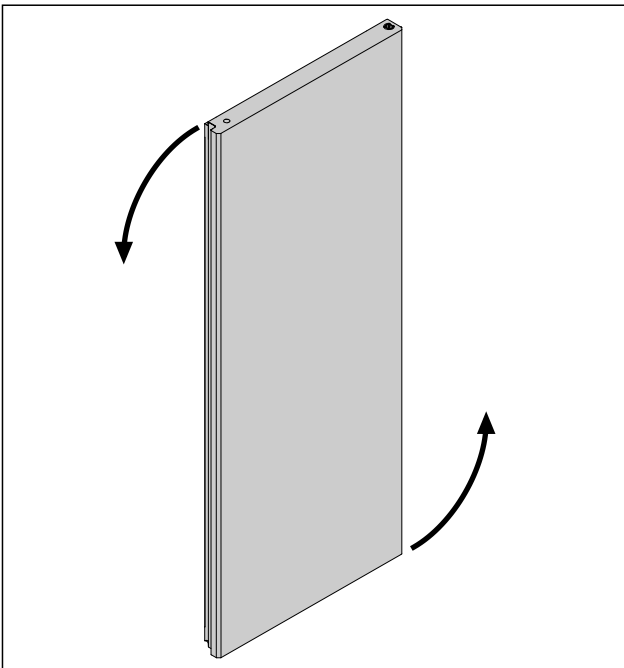

Fig. 48 Example illustration

- Turn the door 180° (180°).

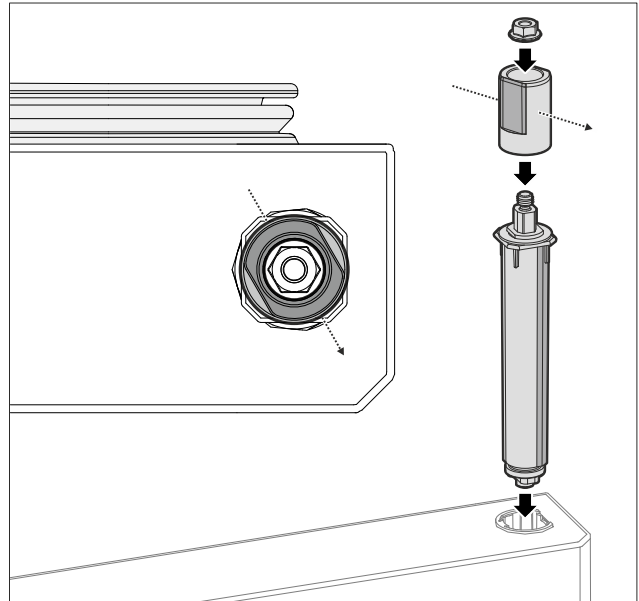

Fig. 49 Right stop

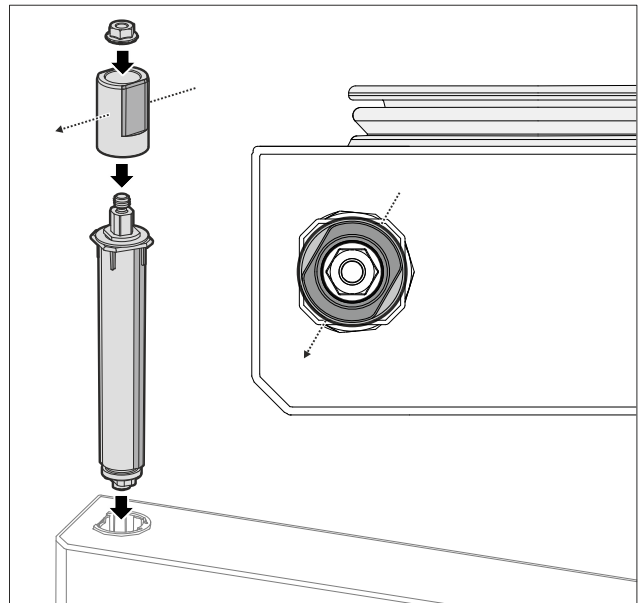

Fig. 50 Left stop

- Assemble the upper lock system and insert it on the hinge side, pay attention to the alignment of the sleeve.

Setting up and connecting

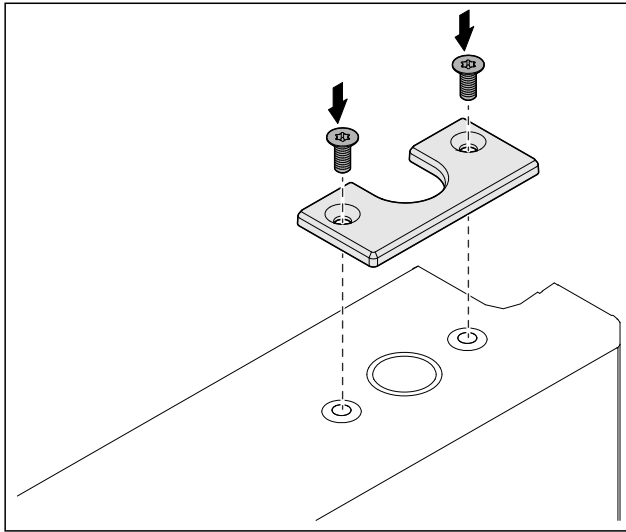

Fig. 51

- ▶ Screw on the cover.
- ▷ The glass door has been changed.

3.5.9 Changing the door (foamed door)*

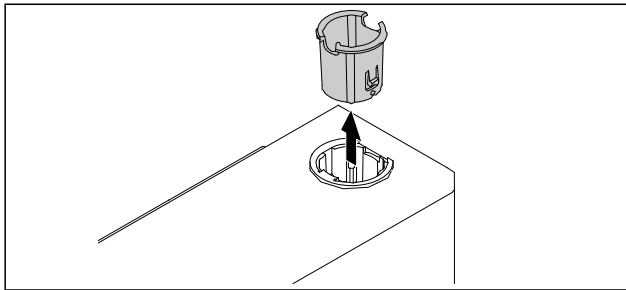

Fig. 52

- ▶ Pull out the hinge bushing on the opposite side.

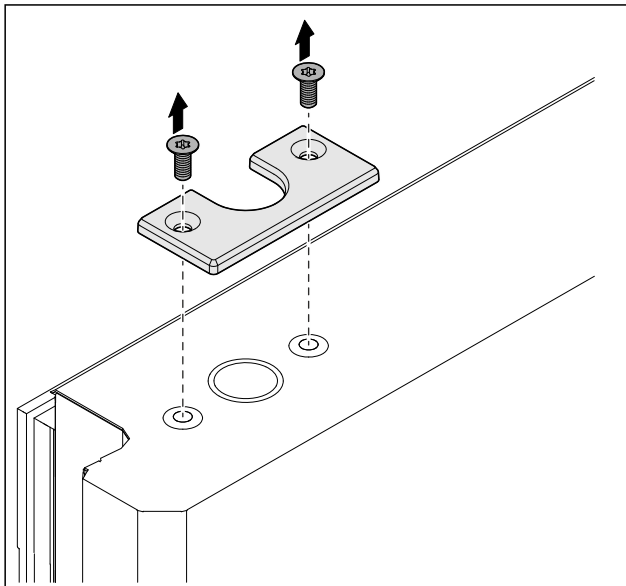

Fig. 53

- ▶ Unscrew the cover.

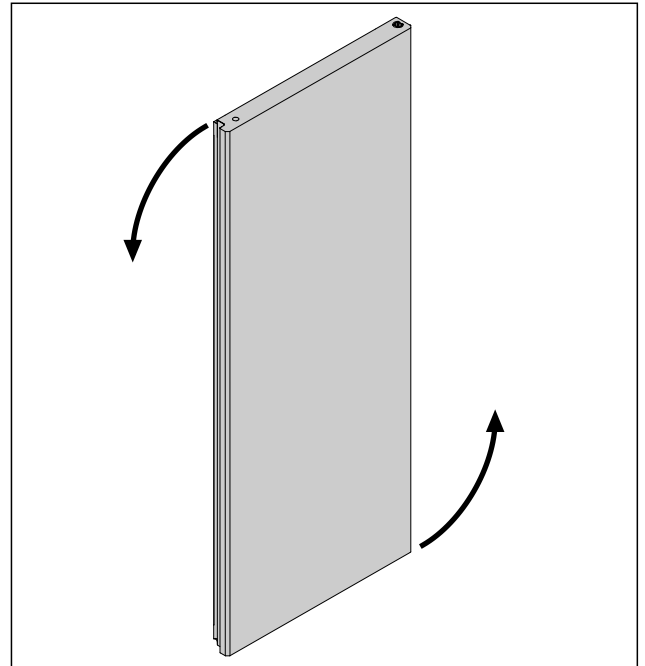

Fig. 54

- ▶ Turn the door 180° (180°).

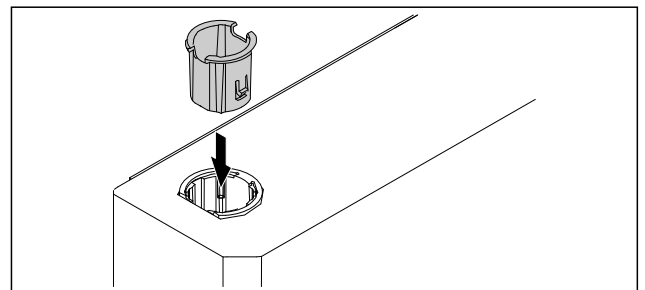

Fig. 55

- ▶ Insert the top hinge bushing on the hinge side (the flat side points outward).

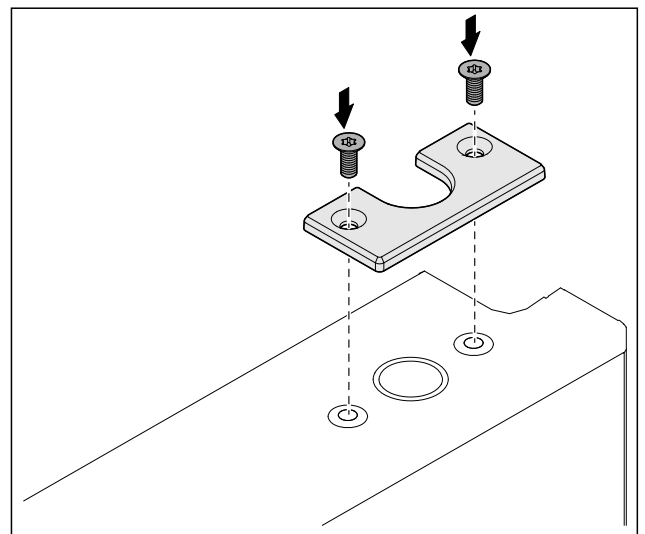

Fig. 56

- ▶ Screw on the cover.
- ▷ The foamed door has been changed.

3.5.10 Installing the lower locking system

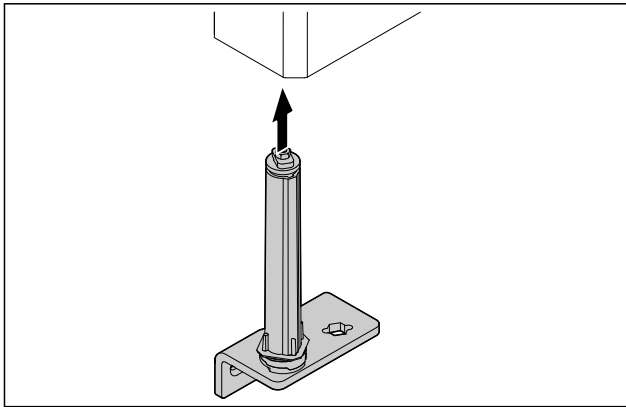

Fig. 57

- ▶ Slide the closing system into the door.

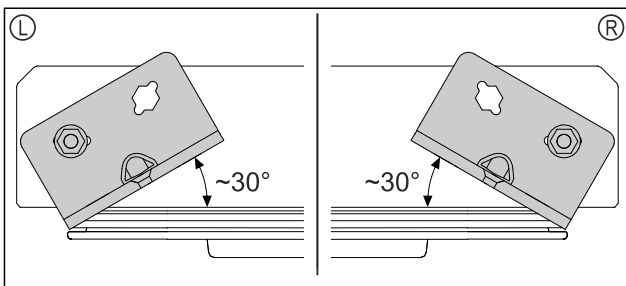

Fig. 58 Door from below

- ▶ Alignment of closing system installation for left-hinged (L) or right-hinged (R).

3.5.11 Installing the door

3.5.11 Installing the door (glass door)*

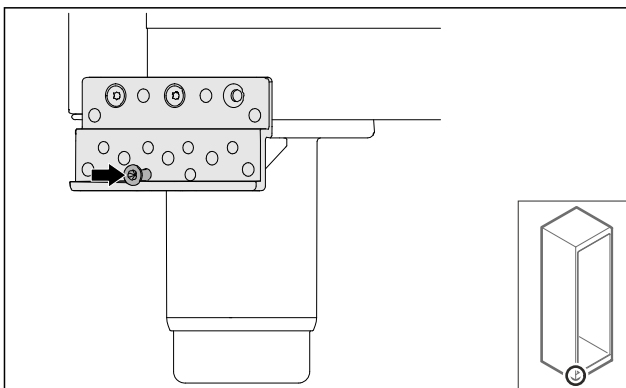

Fig. 59

- ▶ Lightly tighten the screw.

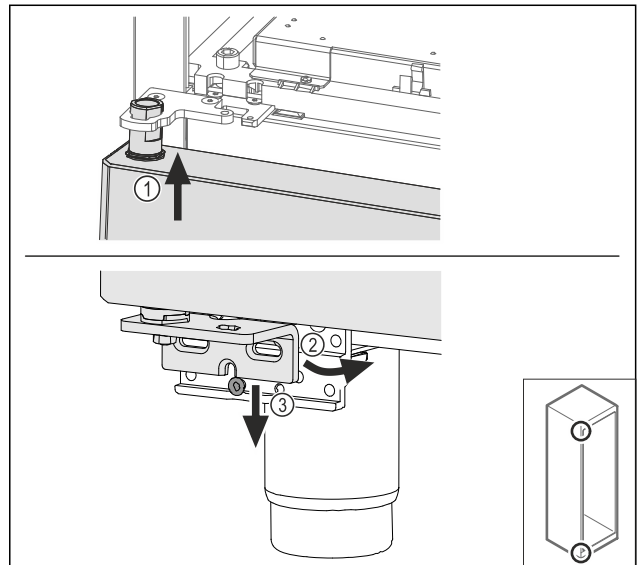

Fig. 60

- ▶ Feed in the door slightly tipped at the top Fig. 60 (1), align the door straight Fig. 60 (2) and fit the swap bearing blow screw Fig. 60 (3) at the bottom.

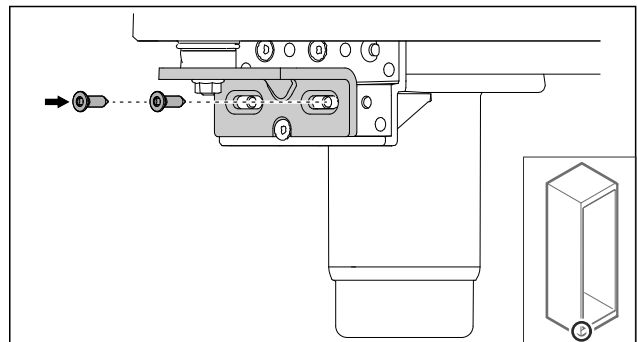

Fig. 61

- ▶ Screw on the door.

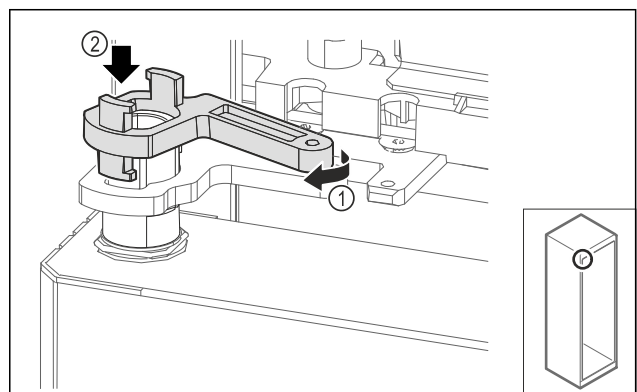

Fig. 62

- ▶ Turn the swap bearing block lock slightly Fig. 62 (1) and place it on the sleeve Fig. 62 (2).

Setting up and connecting

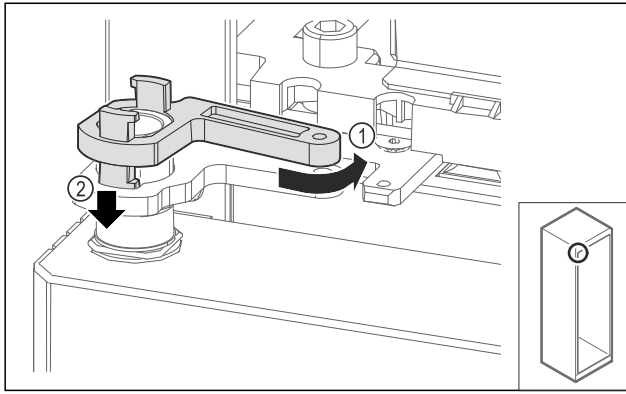

Fig. 63

- ▶ Turn the swap bearing block back slightly Fig. 63 (1), push it downward Fig. 63 (2) and lock it in the hinge angle bar.

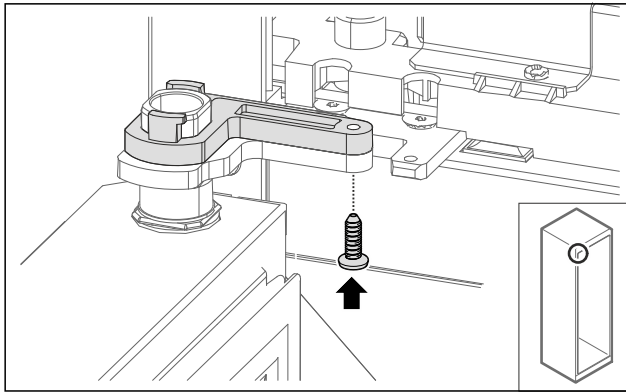

Fig. 64

- ▶ Open the door.
- ▶ Screw on the swap bearing block lock.
- ▶ The glass door is installed.

3.5.11 Installing the door (foamed door)*

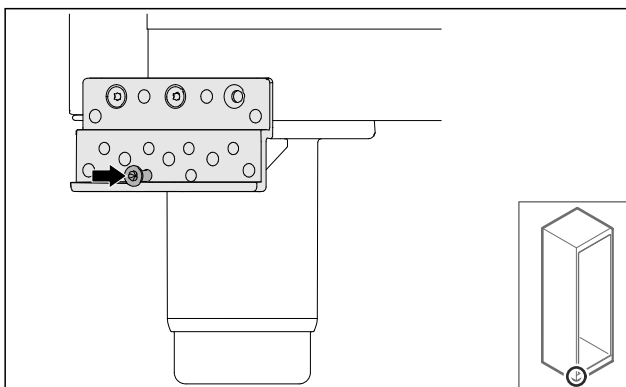

Fig. 65

- ▶ Lightly tighten the screw.

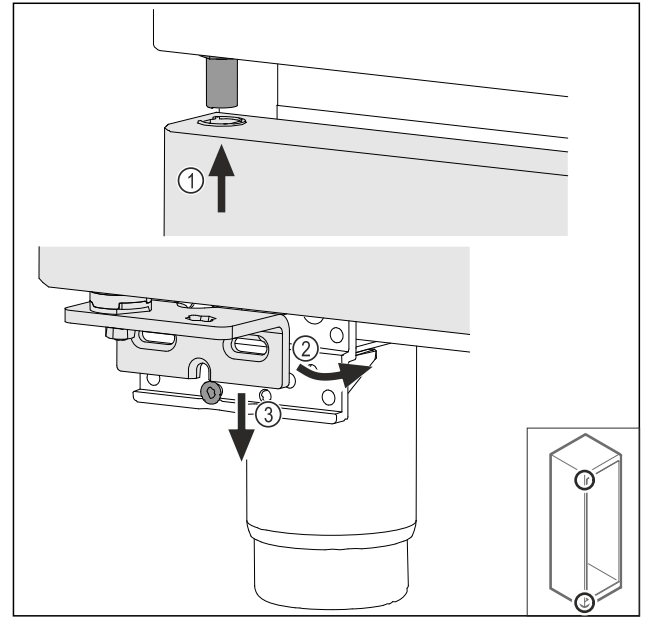

Fig. 66

- ▶ Feed in the door slightly tipped at the top Fig. 66 (1), align the door straight Fig. 66 (2) and fit the swap bearing block screw Fig. 66 (3) at the bottom.

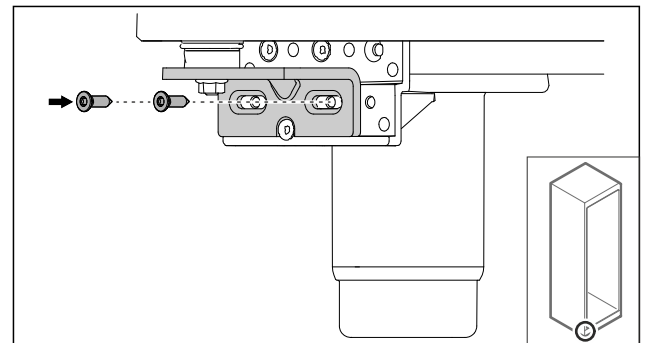

Fig. 67

- ▶ Screw on the door.
- ▶ The foamed door is installed.

3.5.12 Closing the aggregate cover

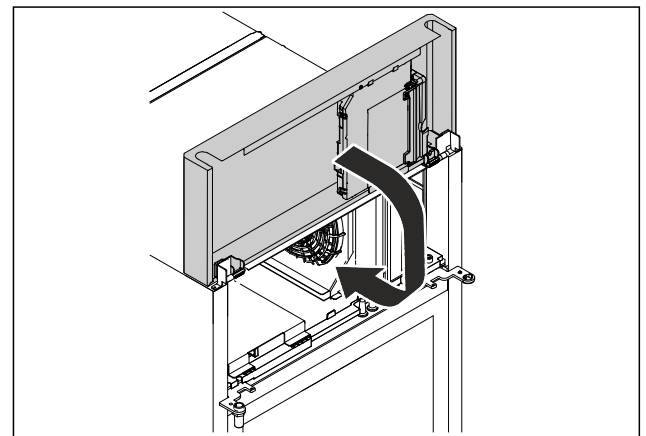

Fig. 68

- ▶ Close the aggregate cover.

Note

Do not pinch the cable.

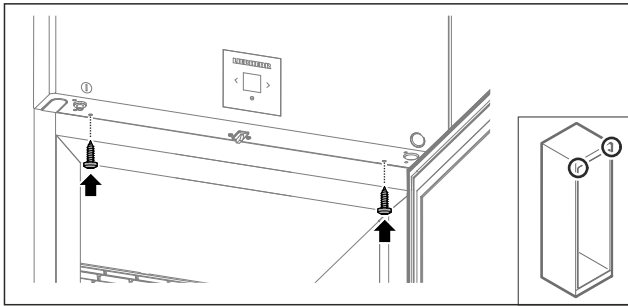

Fig. 69

- ▶ Screw on the aggregate cover.
- ▶ Close the door.
- ▶ The door hinge has been changed.

3.6 Aligning the door

3.6.1 Aligning the door horizontally

If the door is not straight, you can adjust it on the lower hinge.

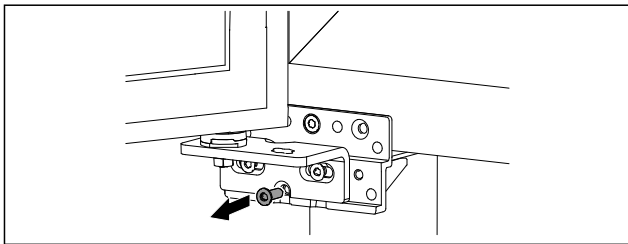

Fig. 70

- ▶ Remove the middle screw on the lower hinge.

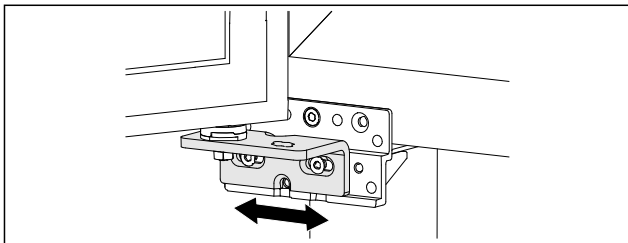

Fig. 71

- ▶ Slightly undo both screws and move the door with the hinge to the left or right.
- ▶ Fully tighten the screws (the middle screw is no longer needed).
- ▶ The door is now straight.

3.7 Connect power cable

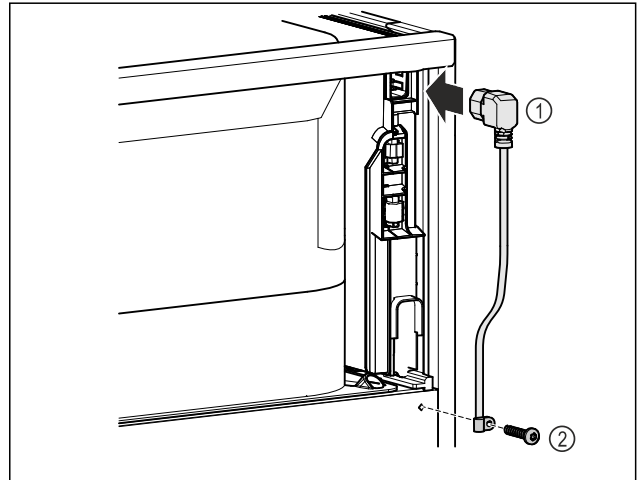

Fig. 72

- ▶ IEC socket of the power cable Fig. 72 (1) on the rear side of the appliance.
- ▶ Install mains tension relief. Fig. 72 (2)

3.8 Mounting the anti-tipping device



WARNING

Danger of injury and damage due to appliance tipping over!

Risk of death and damage to the appliance. An appliance without a mounted anti-tip bracket may tip over while e. g. opening the door or pulling out the shelves.

- ▶ Before putting the appliance in operation: **Always** install the anti-tip bracket as described in the instructions.

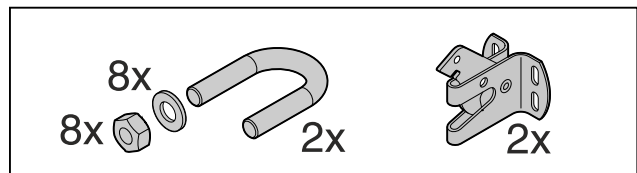

Fig. 73

The anti-tipping device is included with the appliance. It consists of a retaining part, bracket, 8 washers and 8 nuts.

Setting up and connecting

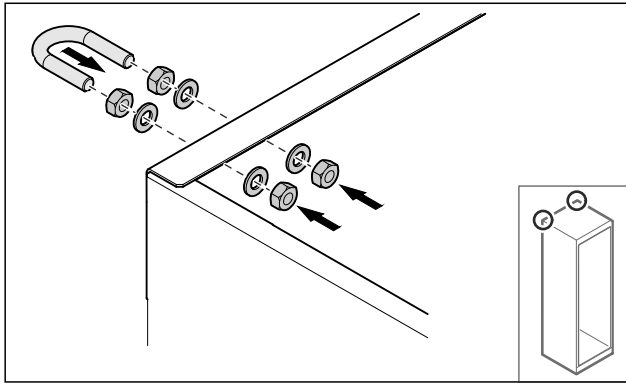

Fig. 74

- ▶ Mount the bracket with included washers and nuts on the appliance.
- ▶ Push appliance with retaining parts mounted against the wall.
- ▶ Level out the appliance.

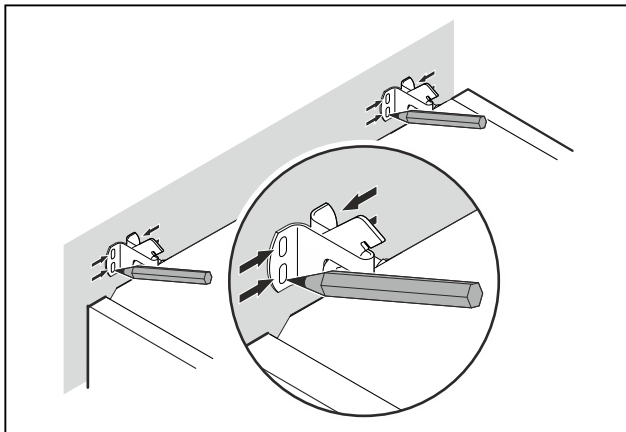

Fig. 75

- ▶ Make markings on the wall.
- ▶ Remove appliance.

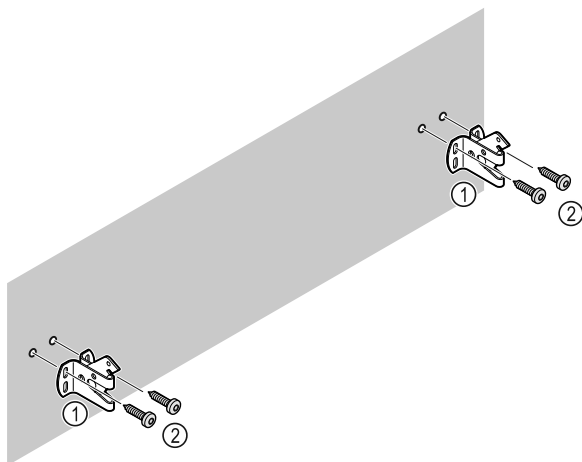

Fig. 76

Use fixing material (e.g. wall anchors) which is appropriate for the nature of the wall or floor (wood, concrete) and sufficient attachment points.

- ▶ Attach retaining hooks.

3.9 Setting up the appliance



CAUTION

Risk of injury and damage.

- ▶ Use 2 people to set up the appliance.



CAUTION

Risk of injury and damage.

The door can strike against the wall and become damaged as a result. In the case of glass doors, the damaged glass can cause injuries.

- ▶ Protect the door from striking against the wall. Attach a door stopper, e.g. felt stopper, to the wall.

- ▶ Connect all necessary components (e.g. power cable) to the back of the appliance and route to the side.

Note

Cables can be damaged.

- ▶ Do not crush the cable when pushing the appliance back.

- ▶ Slide the appliance up against the wall so that the retaining parts latch into the retaining hooks.
- ▶ The appliance is now secured against tipping.
- ▶ It can be released by folding back the retaining hooks.
- ▶ The distance between the upper edge of the appliance and the ceiling must be at least 300 mm (11 13/16 in).

3.10 Setting up multiple appliances

NOTICE

Risk of damage due to condensation between the side walls.

- ▶ Do not set up the appliance directly next to another refrigeration appliance.
- ▶ Set up appliances with a space of 3 cm (1.18 in) between appliances.
- ▶ Only set up multiple appliances up to temperatures of 35 °C (95 °F) and 65 % humidity next to one another.
- ▶ At higher levels of humidity, increase the space between appliances.

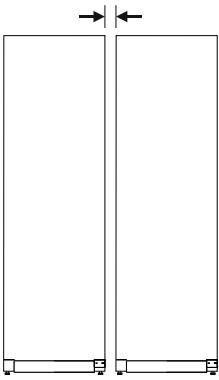

Fig. 77 Side-by-side set up

Note

A side-by-side kit is available as an accessory via Liebherr Customer Service. (see 10.4 Customer Service)

3.11 After setup

- ▶ Peel off the protective films. *
- ▶ Clean the appliance. (see 9.3 Cleaning the appliance)
- ▶ If necessary: Disinfect the appliance.
- ▶ Keep the invoice so you have the appliance and dealer information available if needed.

3.12 Disposal of packaging



WARNING

Danger of suffocation from packaging materials and films!

- ▶ Do not allow children to play with packaging materials.

The packaging is made from recyclable materials:

- Corrugated card/cardboard
 - Parts made of foamed polystyrene
 - Films and bags from polyethylene
 - Packing bands from polypropylene
 - Wood frame nailed together with a polyethylene window*
- ▶ Take the packaging material to an official collection point.

3.13 Connecting the appliance to the power supply



WARNING

Danger of electric shock and injury due to damaged appliance or damaged mains cable!

Cuts and fatal injury. If the appliance or the mains cable is damaged during transport, you may be electrocuted. You could also cut yourself on damaged parts of the appliance housing.

- ▶ Check the appliance and the mains cable for damage after transport.
- ▶ Never put the appliance into operation if the appliance or the mains cable are damaged.
- ▶ Contact Customer Service.

You can connect your appliance to the mains using the power cable supplied separately. The mains power cable has an appliance coupler at one end and a mains plug at the other end.

Make sure that the following requirements are fulfilled:

- The appliance and power cable are undamaged.
- The appliance is set up in accordance with the regulations. (see 3.7 Connect power cable)
- Requirements for the electrical connection are met.
- Dimensions for connection in accordance with regulations are known and observed.
- Mains voltage and frequency correspond to the specifications on the type plate.
- The socket is grounded and fused in accordance with regulations.
- The tripping current for the fuse is between 10 A and 16 A.
- Outlet is easily accessible and is not behind the appliance.

NOTICE

Danger of damage to incorrect operation!

Damage to the electrical components of the appliance.

- ▶ Only use the supplied power cable.



WARNING

Danger of fire due to incorrect connection!
Burns.

Damage to the appliance.

- ▶ Do not use an extension cord.
- ▶ Do not use a multipoint connector strip.

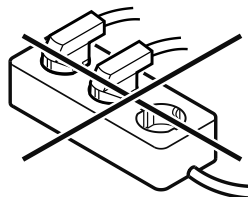

Functionality of the Touch & Swipe display

NOTICE

Danger of damage to incorrect connection!
Damage to the appliance.

▶ Do not connect the appliance to a stand-alone inverter, e.g. solar power systems and petrol generators.



- ▶ Connect the mains plug of the power cord to the power supply. Ensure the main plug is firmly plugged into the outlet.
- ▶ The standby symbol appears in the display.
- ▶ If no action is taken within 60 seconds: Standby symbol fades or disappears.
- ▶ Appliance is connected. For initial commissioning, see the next chapter or the operating instructions.





4 Functionality of the Touch & Swipe display

You operate your appliance using the Touch & Swipe display. You select appliance functions in the Touch & Swipe display (hereafter referred to as display) by tapping them. If you do not perform any action on the display for 10 seconds, the display either jumps back to the higher-level menu or directly to the status display.

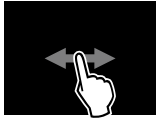
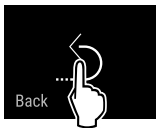
4.1 Navigation and symbol explanation

In the illustrations, different symbols are used to navigate the display. The following table describes these symbols.

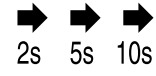

Symbol	Description
	Briefly touch the display: Activates/deactivates function. Confirms selection. Opens submenu.
	Touch the display for a specified time (e.g. 3 seconds): Activates/deactivates function or value.
	Swipe left or right: Navigate in the menu.
	Briefly touch the Back symbol: Jumps back one menu level.

Symbol	Description
	Press and hold the Back symbol for 3 seconds: Jumps back to the status display.
	Briefly touch the Back symbol at the top left: Jumps back one menu level.
	Arrow with clock: It takes more than 10 seconds for the following message to appear in the display.
	Arrow with a time indication: It takes the specified amount of time until the following message appears in the display.
	“Open Settings menu” symbol: Navigates to the Settings menu and opens the settings menu. If necessary: Navigate to the desired function in the Settings menu. (see 4.2.1 Opening the Settings menu)
	“Open Advanced menu” symbol: Navigates to the Advanced menu and opens the advanced menu. If necessary: Navigate to the desired function in the Advanced menu. (see 4.2.2 Opening expanded menu)
No action for 10 seconds	If you do not perform any action on the display for 10 seconds, the display either jumps back to the higher-level menu or directly to the status display.

Note: Illustrations of the display are shown in the English version.

4.2 Menus

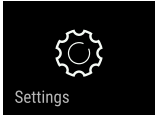
The appliance functions are distributed over various menus:

Menu	Description
Main menu	When you switch the appliance on, you are automatically in the main menu. From here you can navigate to the most important appliance functions, to the Settings menu and to the Advanced menu.
 Settings menu	The Settings menu contains additional appliance functions for setting up your appliance.
 Advanced menu	The advanced menu contains special appliance functions for setting up your appliance. Access to the Advanced menu is protected by the numerical code 151 .

4.2.1 Opening the Settings menu

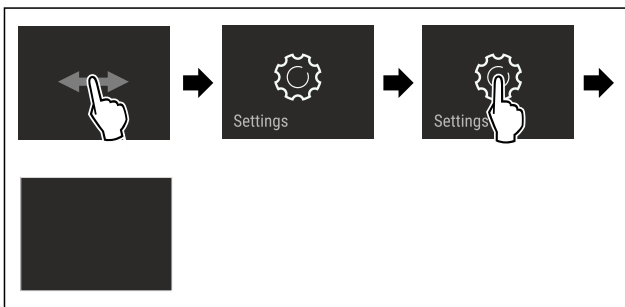

Fig. 78 Example illustration

- ▶ Carry out action steps according to the illustration.
- ▷ Settings menu is open.
- ▶ If necessary: Navigate to the desired function.

4.2.2 Opening expanded menu

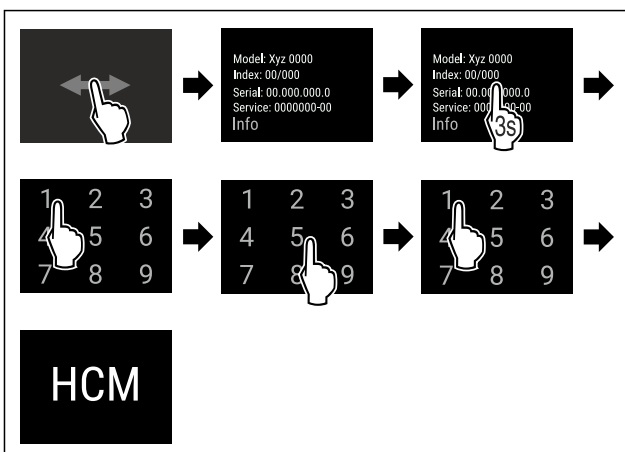

Fig. 79 Access with numerical code **151**

- ▶ Carry out action steps according to the illustration.
- ▷ Expanded menu is open.

- ▶ If necessary: Navigate to the desired function.

4.3 Sleep mode

If you do not touch the display for 1 minute, the display switches to sleep mode. In sleep mode, the display brightness is dimmed.

4.3.1 Ending sleep mode

- ▶ Touch the display briefly with your finger.
- ▷ Sleep mode is ended.

5 Start-up

5.1 Switching on the appliance (first use)

Make sure that the following requirements are fulfilled:

- Appliance is set up and connected.
- All adhesive strips, adhesive and protective films and transport locks are removed from inside and outside the appliance.

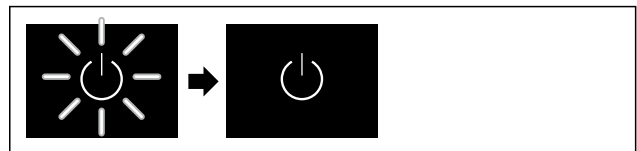

Fig. 80 Example illustration

- ▶ Standby symbol appears is flashing: Wait until the start process has completed.
- ▷ Display shows the standby symbol.

If the appliance has been supplied with factory settings, the screen language and the date/time first need to be set when using the appliance for the first time.

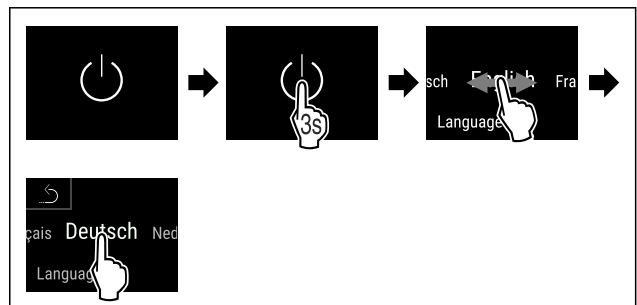

Fig. 81

- ▶ Carry out action steps according to the illustration.
- ▷ Language is set.

Start-up

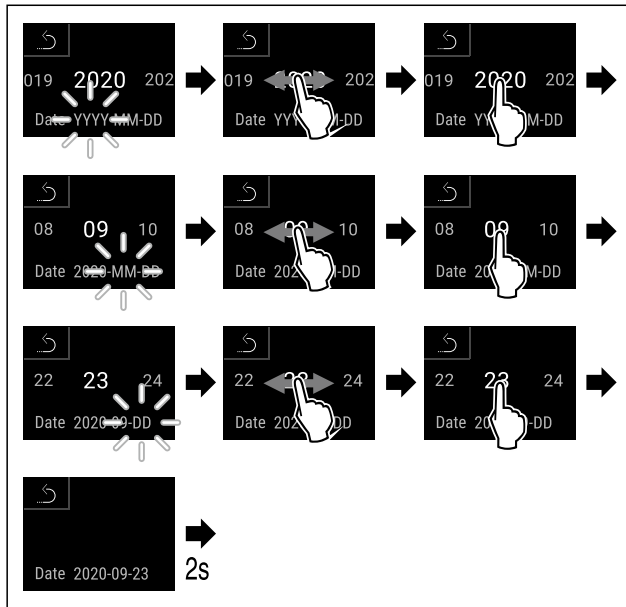

Fig. 82

- ▶ Carry out action steps according to the illustration.
- ▷ Date is set.

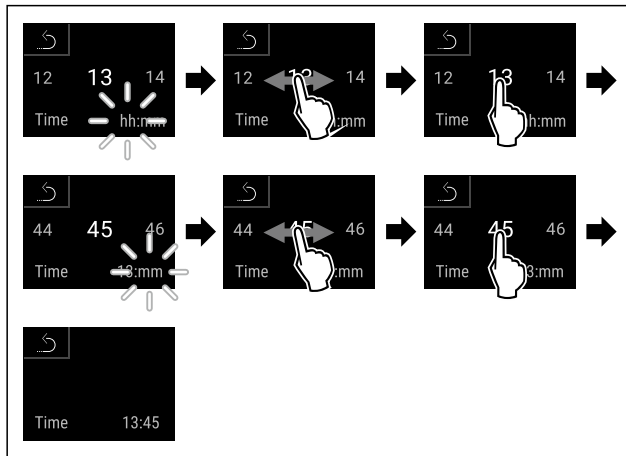

Fig. 83

- ▶ Carry out action steps according to the illustration.
- ▷ Time is set.

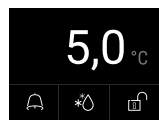

Fig. 84 Status display

- ▶ The appliance is ready for use once the temperature appears in the display.
- ▶ The temperature display flashes until the set temperature is reached.

5.2 Using equipment

5.2.1 Inserting the snap strips

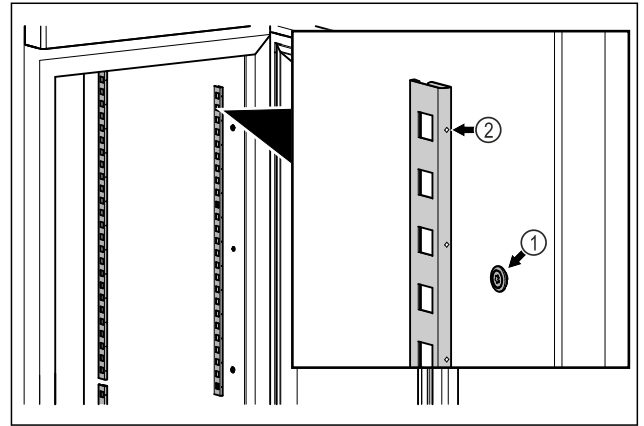

Fig. 85 Example illustration

- ▶ Hook the snap strips into the suspension Fig. 85 (1).
- ▶ Mark Fig. 85 (2) must point forward.

5.2.2 Inserting support rail

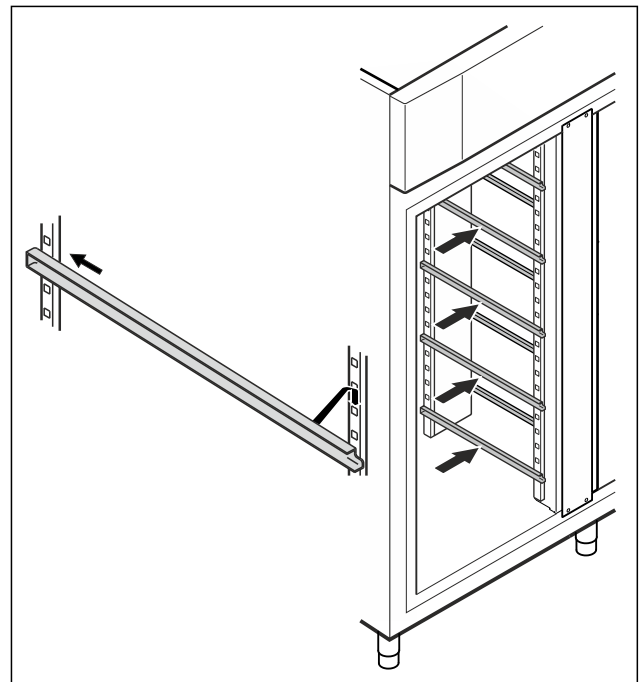

Fig. 86 Example illustration

- ▶ Insert support rail into rear snap-in bar and attach at front.

5.3 Center grid shelf

5.3.1 Inserting center grid shelf

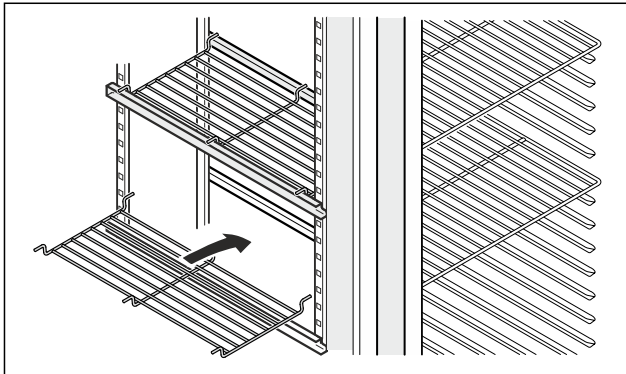

Fig. 87 Example illustration

- ▶ Place center grid shelf on to the support rails.

6 Storage

6.1 Information regarding storing items

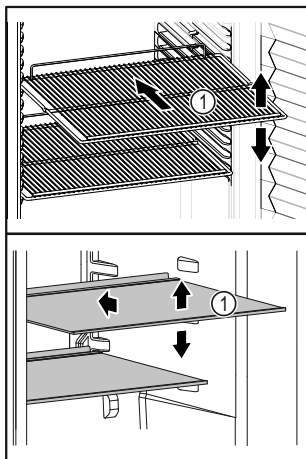



Fig. 88 Example illustration

When stocking items, observe the following:

- ❑ If shelves Fig. 88 (1) can be moved, adjust the shelves according to the height.
- ❑ Observe maximum load weight. (see 10.1 Technical data)
- ❑ Do not stock appliance until the storage temperature has been reached (maintain cold chain).
- ❑ Refrigerated goods must not touch the rear wall.
- ❑ Refrigerated goods do not stick out beyond the shelves.
- ❑ Keep liquids in closed containers.
- ❑ Leave space when storing items for refrigeration to ensure adequate air circulation.
- ❑ Do not stack refrigerated products above the indicated height. 

This is important for free air circulation and even temperature distribution in the interior.

7 Use

7.1 Control and display elements

The display provides a quick overview of the current appliance status, the temperature setting, the status of functions and settings as well as alarm and error messages.

They are operated directly on the Touch & Swipe display by swiping and tapping.

Functions can be activated or deactivated and settings values can be changed.

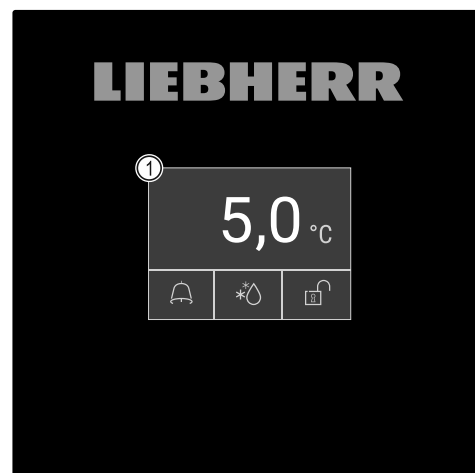

Fig. 89 Touch & Swipe display

- (1) Status display

7.1.1 Status display

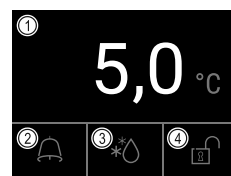

Fig. 90 Status display

- (1) Actual temperature
- (2) Alarm status
- (3) Defrosting status
- (4) Door locking status

The status display is the initial display.













It shows the temperature in the middle and three symbols in the lower area. The status display can show other different display symbols.

You can navigate from the functions and settings from the status display.

7.1.2 Display symbols

The display symbols provide information about the current status of the appliance.









Use

Symbol	Appliance status
	Standby symbol Appliance is switched off.
	Standby symbol (flashing) Appliance is starting up.
	Temperature (flashing) Target temperature not yet reached. Appliance cooling to set temperature.
	Status display (white border) Appliance is locked.
	D in the display Appliance is in demo mode.
	Maintenance display (yellow) The set time interval has expired.
	Full data storage (yellow) The data storage (999 hours) is full. The oldest data are now overwritten.
	Full alarm storage (yellow) The alarm storage is full. Delete individual alarms or the entire storage.
	Manual door opening (yellow) The closed door was manually opened.
	Error symbol (red) Appliance is in error state.
	Background (blue) Active setting or active function
	Bars (increasing) Press for 3 seconds to activate the setting.

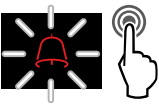
Symbol	Appliance status
	Bars (decreasing) Press for 3 seconds to deactivate the setting.

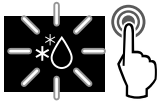
Status display symbols

The additional symbols on the bottom edge of the status display ensure quick access to the alarm information and details about the appliance's status.

Symbol	Appliance status
	Alarm symbol (gray) Alarm archive is empty. A brief tap opens the alarm archive.
	Alarm symbol (white) There are confirmed alarms in the alarm archive. A brief tap opens the alarm archive.
	Alarm symbol (red) There are still unconfirmed alarms in the alarm archive. A brief tap opens the alarm archive.
	Alarm symbol (red, flashing) There is an active alarm in the archive. A brief tap opens the alarm archive.
	Defrosting symbol (gray) No active defrosting process.
	Defrosting symbol (white, flashing) The defrost process is active. Briefly tapping opens the defrost appliance function. (see 7.2.22 Defrosting)
	Defrosting symbol (white) The automatic defrost process is active. The function cannot be canceled.
	Door lock symbol (white, closed) The door lock is active. A brief tap opens the code entry for opening the door. (see 7.2.6 Door lock)
	Door lock symbol (white, open) The door lock is inactive. A brief tap opens the code entry for locking the door. (see 7.2.6 Door lock)

Additional status display symbols

7.1.3 Acoustic signals

A signal sounds in the following cases:

- If a function or a value is confirmed.

- If a function or a value can neither be activated nor deactivated.
- As soon as a fault occurs.
- If there is an alarm message.

The alarms can be switched on and off in the customer menu.

7.2 Appliance functions

7.2.1 Notes on the appliance functions

The appliance functions are set at the factory so that your appliance is fully functional.

Before you alter, activate or deactivate the appliance functions, make sure that the following requirements are met:

- ❑ You have read and understood the descriptions of how the display works. (see 4 Functionality of the Touch & Swipe display)
- ❑ You have familiarized yourself with the operating and display elements of your appliance. (see 7.1 Control and display elements)

7.2.2 Switching appliance on and off



This function makes it possible to switch the entire appliance on and off.

Switching on appliance

Without activated demo mode:

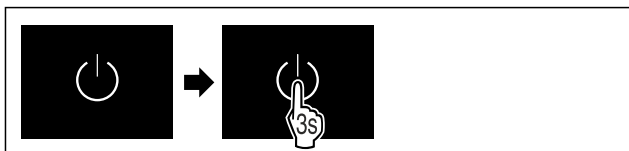

Fig. 91

- ▶ Carry out action steps according to the illustration.

With activated demo mode:

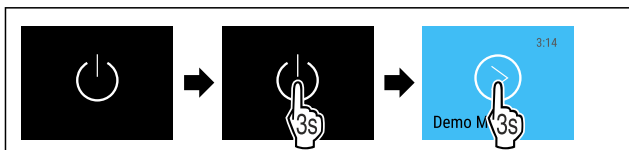

Fig. 92

- ▶ Carry out action steps according to the illustration.

Note

Deactivate demo mode before the countdown ends.

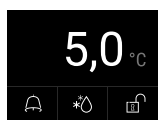

Fig. 93 Status display

- ▶ The temperature appears in the display.

Switching off appliance



Fig. 94

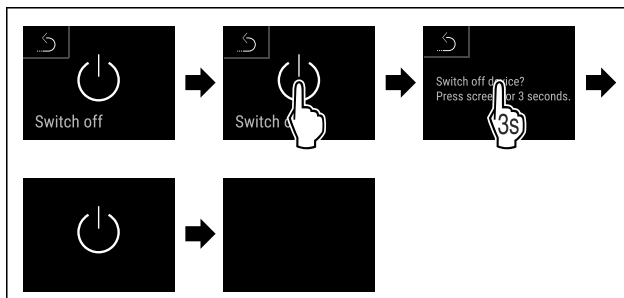

Fig. 95

- ▶ Carry out action steps according to the illustration.
- ▶ Standby symbol is shown in the display.
- ▶ Display switches off after about 10 minutes.

7.2.3 Temperature



The temperature depends on the following factors:

- How often the door is opened
- How long the door is open for
- The room temperature of the installation site
- The type, temperature and amount of refrigerated items

Note

The temperature may differ from the temperature displayed in some areas of the interior.

At the correct temperature, refrigerated items will keep for longer. This avoids disposing of food unnecessarily.

Setting the temperature

The following steps describe how to increase the temperature, e.g. from 12.1 °C (54 °F) to 15.5 °C (60 °F).

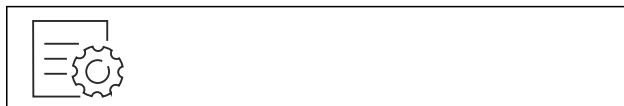

Fig. 96

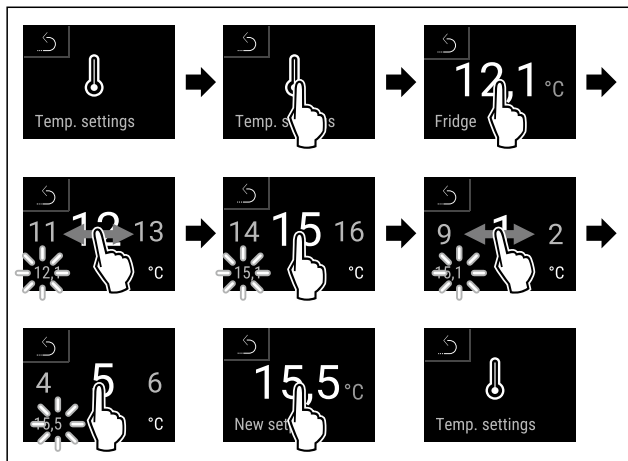

Fig. 97

- ▶ Carry out action steps according to the illustration.
- ▶ Temperature is set.

7.2.4 Temperature recording



The appliance displays the minimum and maximum temperatures of the interior via this function. The recording of these temperatures starts automatically after the appliance is switched on; they are recorded at one minute intervals. A note indicating that the data memory is full is displayed after 999 hours (approx. 40 days). The temperature recording should then be reset.

Note

The entire temperature history as well as alarm and service messages are also recorded independently of this function. This data can be exported and backed up on a USB storage medium. (see 7.2.23 Data download (data backup))

If there is an additional product sensor installed on the appliance, there is the option of selecting this sensor to display the minimum and maximum temperatures. (see 7.2.24 Sensor calibration)

Note

The temperature recording should be reset once **after reaching the set temperature** when the appliance is commissioned. (see Resetting temperature recording) This ensures that the value for the maximum temperature is a meaningful value.

Displaying temperature recording

The temperature recording displays the length of the recording and the minimum and maximum temperatures measured during this period of time.



Fig. 98

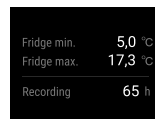

Fig. 99

- ▶ Status screen with the temperature recordings is displayed.

Resetting temperature recording

The displayed minimum and maximum temperatures can be reset at any time. This deletes the displayed values and the recording interval starts again.



Fig. 100

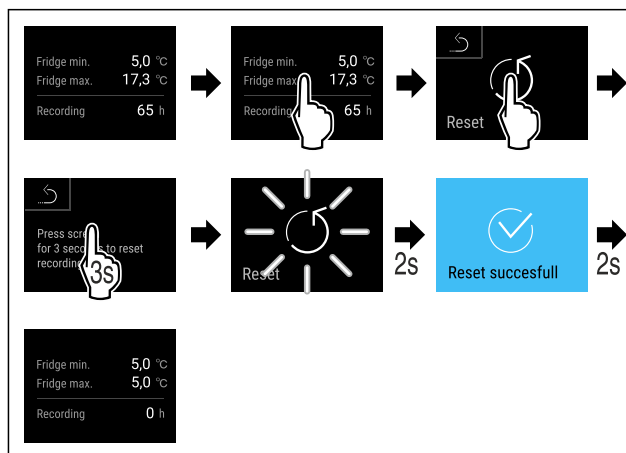

Fig. 101

- ▶ Carry out action steps according to the illustration.
- ▶ Temperature recording is reset.

7.2.5 Lighting



The appliance is equipped with interior lighting. You can keep the interior lighting on continuously. (see Switching on lighting*) *

The interior lighting comes on when you open the appliance door.

You can also deactivate this function. (see Switching off the lighting when opening the door*) *

Switching on lighting*

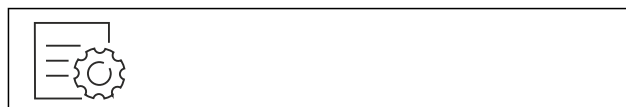

Fig. 102

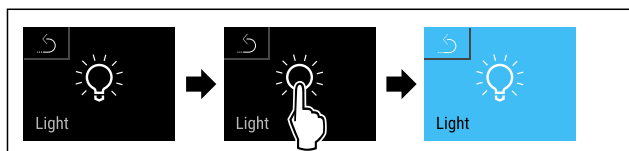

Fig. 103

- ▶ Carry out action steps according to the illustration.
- ▶ Lighting is switched on.

Switching off lighting*

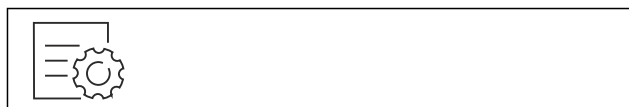

Fig. 104

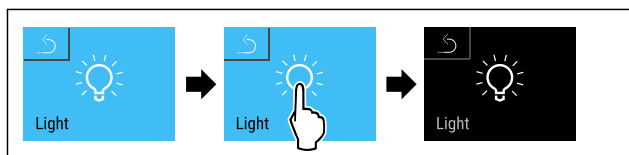

Fig. 105

- ▶ Carry out action steps according to the illustration.
- ▶ Lighting is switched off.

Switching off the lighting when opening the door*



Fig. 106

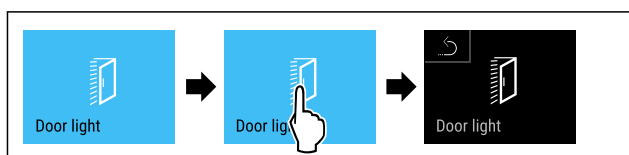

Fig. 107

- ▶ Carry out action steps according to the illustration.
- ▶ The lighting is switched off when the door is opened.

Switching on the lighting when opening the door*



Fig. 108

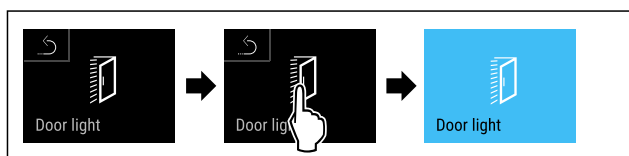

Fig. 109

- ▶ Carry out action steps according to the illustration.
- ▶ The lighting is switched on when the door is opened.

7.2.6 Door lock



The appliance is fitted with an electronic door lock. **When used for the first time, the door is unlocked** and you can open it.

This function means the appliance can be secured against the unwanted removal of items.

You have the following setting options for this:

- Locking the door using a door code.
- Unlocking the door using a door code.
- Activating automatic locking.
- Deactivating automatic locking.
- Setting a time delay for automatic locking.
- Changing the door code. (see 7.2.9 Access codes)
- Resetting the door code. (see 7.2.9 Access codes)

Locking the door using a door code

Note

- ▶ In the following example, the factory-set PIN code: **1 1 1 1** is used.

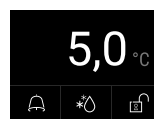

Fig. 110 Status display

Starting from the status display, the door code entry begins by pressing the open padlock symbol.

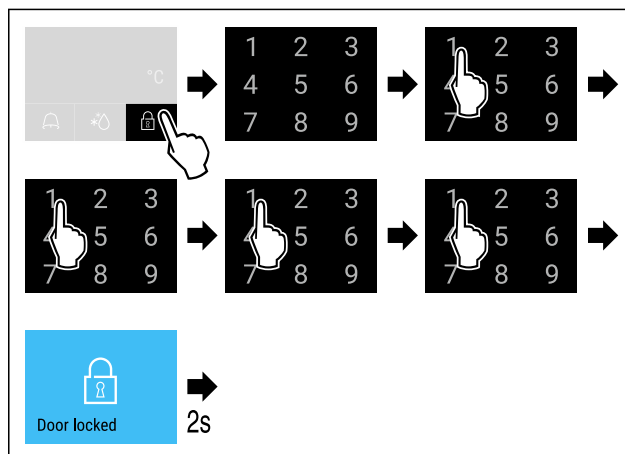

Fig. 111 Locking door using door code 1 1 1 1.

- ▶ Carry out action steps according to the illustration.

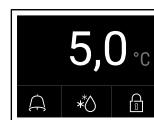

Fig. 112 Status display with white border

- ▶ The door is locked.

Use

Unlocking the door using a door code

Note

- ▶ In the following example, the factory-set PIN code: **1 1 1 1** is used.

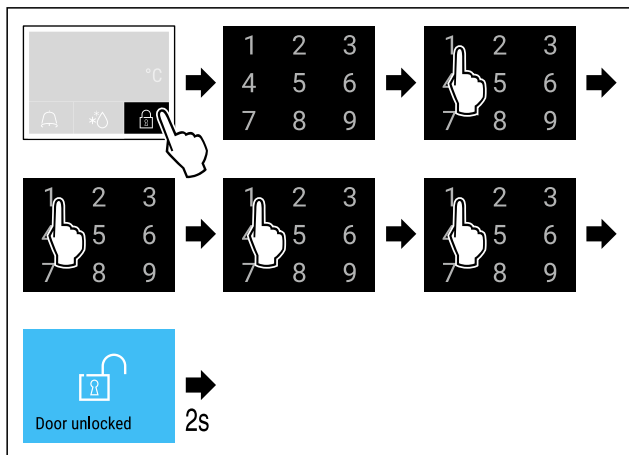

Fig. 114 Unlock door with door code 1 1 1 1.

- ▶ Carry out action steps according to the illustration.

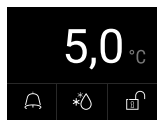

Fig. 115 Status display

- ▶ The status display with an open padlock symbol appears.
- ▶ The door is unlocked.

Activating automatic locking



Fig. 116

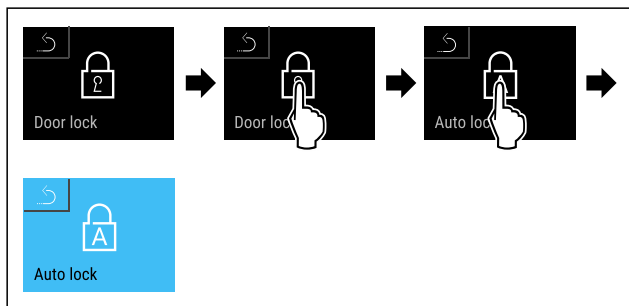

Fig. 117

- ▶ Carry out action steps according to the illustration.
- ▶ Automatic locking is activated.
- ▶ The time delay (see Setting time delay for automatic locking) can now be set.

Note

You can continue to lock and unlock the door using the remote control or by entering the door code.

Deactivating automatic locking



Fig. 118

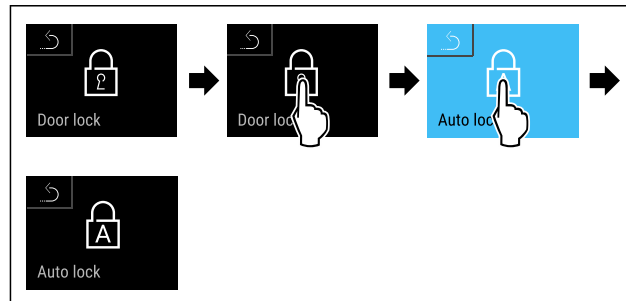

Fig. 119

- ▶ Carry out action steps according to the illustration.
- ▶ Automatic locking is deactivated.

Setting time delay for automatic locking

This function sets the time delay of the automatic door lock after a door is opened.

Make sure that the following requirements are fulfilled:

- The automatic door locking (see Activating automatic locking) is activated.



Fig. 120

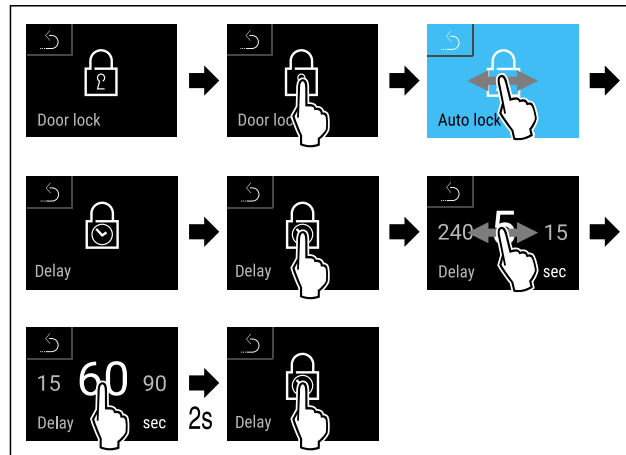

Fig. 121 The following values can be set: 5, 15, 60, 90, 120, 180 and 240 seconds

- ▶ Carry out action steps according to the illustration.
- ▶ Time delay is set.

Changing the door code

(see 7.2.9 Access codes)

Resetting the door code

(see 7.2.9 Access codes)

7.2.7 SmartLock



To prevent the removal of the cooled produce, this function enables automatic door locking after the temperature alarm has been triggered. (see 7.2.25 Temperature alarm) The locking delay time can be set. The door can then only be opened with the SmartLock PIN code.

Application:

- Activating the SmartLock.
- Deactivating the SmartLock.
- Setting the locking delay.
- Unlocking the door lock with the SmartLock PIN code.
- Changing the SmartLock PIN code. (see 7.2.9 Access codes)
- Resetting the SmartLock PIN code. (see 7.2.9 Access codes)

Activating SmartLock

Note

- ▶ In the following example, the factory-set PIN code: **1 1 1 1** is used.



Fig. 122

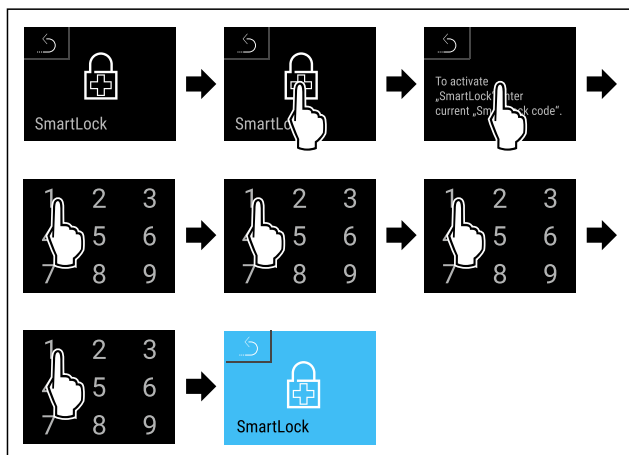

Fig. 123

- ▶ Carry out action steps according to the illustration.
- ▶ SmartLock is activated.
- ▶ The locking delay interval can now be selected. (see Setting locking delay)

Deactivating SmartLock

Note

- ▶ In the following example, the factory-set PIN code: **1 1 1 1** is used.



Fig. 124

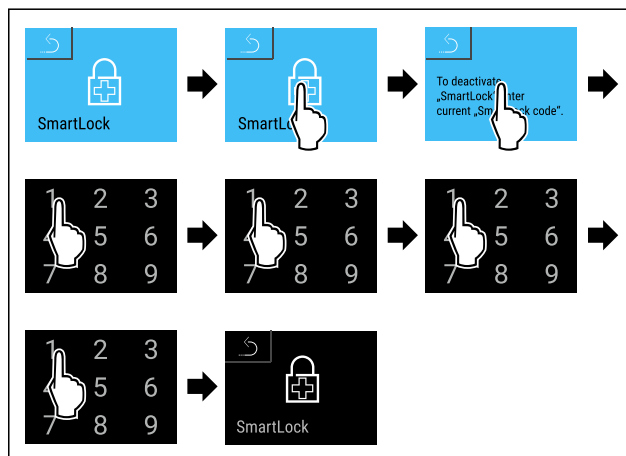

Fig. 125

- ▶ Carry out action steps according to the illustration.
- ▶ SmartLock is deactivated.

Setting locking delay

Make sure that the following requirements are fulfilled:

- SmartLock must be activated. (see Activating SmartLock)



Fig. 126

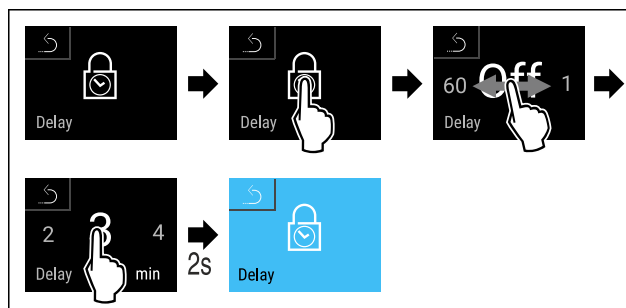

Fig. 127 The following values can be set: Off (no waiting time) up to 60 minutes; in 1-minute increments

- ▶ Carry out action steps according to the illustration.
- ▶ The time for the locking delay has been set.

Unlocking door lock with SmartLock PIN code

After the temperature alarm has been triggered (see 7.2.25 Temperature alarm) the door is locked automatically via the SmartLock function.

Opening is now only possible with the SmartLock PIN code.

Use

Note

► In the following example, this SmartLock PIN code is used: **2 3 4 5**

Entering the SmartLock PIN code starts from the status display. Information about the SmartLock function and the temperature recording for the temperature alarm are displayed.

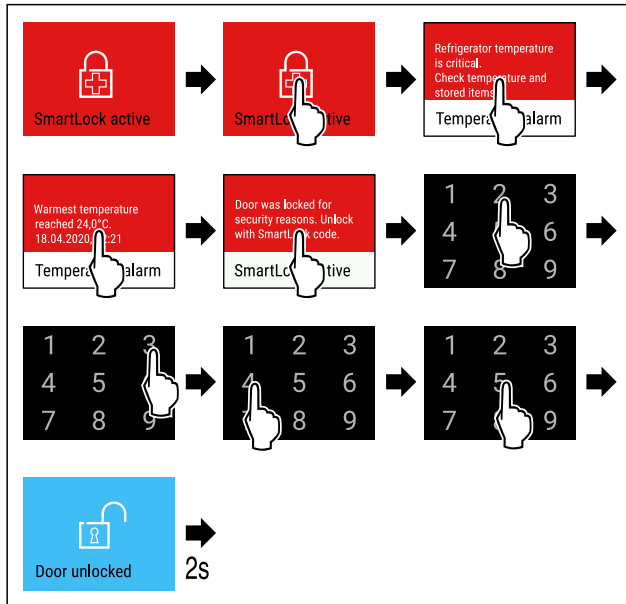

Fig. 128

► Carry out action steps according to the illustration.
 ► The door is unlocked.

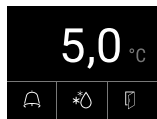

Fig. 129 Status display

► The temperature appears in the display.

Changing the SmartLock PIN code

(see 7.2.9 Access codes)

Resetting the SmartLock PIN code

(see 7.2.9 Access codes)

7.2.8 Settings menu access protection



This function enables the settings menu access protection via a four-digit PIN code.

Application:

- Prevent settings and functions being changed unintentionally.
- Prevent the appliance from being switched off unintentionally.
- Prevent the temperature from being adjusted unintentionally.

Note

► In the following examples, the PIN code set at the factory: **1 1 1 1** is used.

Activating the settings menu access protection



Fig. 130

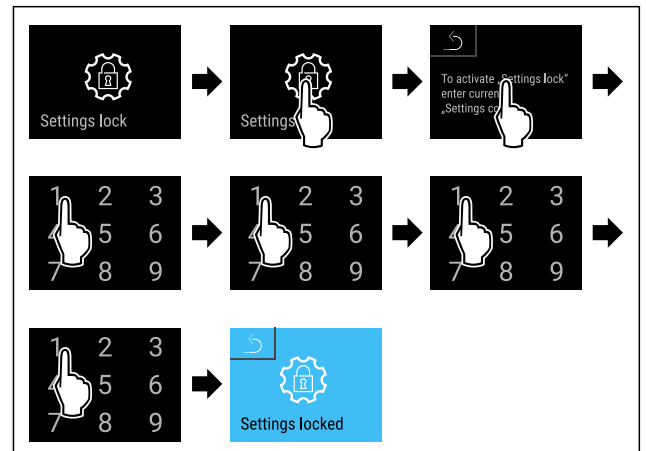

Fig. 131

► Carry out action steps according to the illustration.
 ► Settings menu access protection is activated.

Changing the access protection PIN code for the settings menu

(see 7.2.9 Access codes)

Deactivating the settings menu access protection

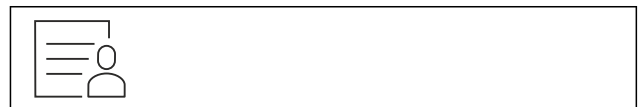

Fig. 132

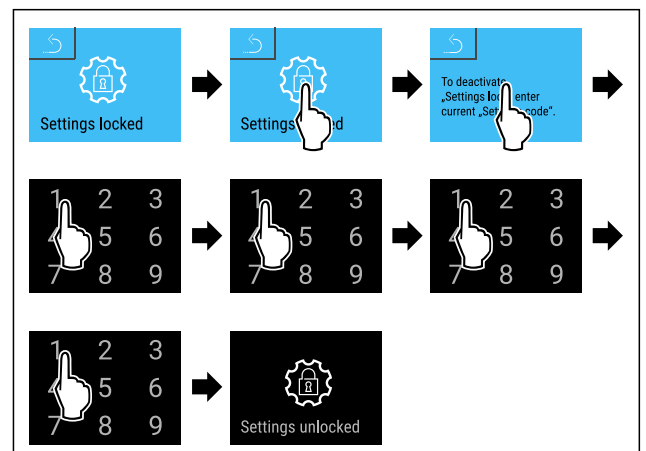

Fig. 133

► Carry out action steps according to the illustration.
 ► Settings menu access protection is deactivated.

Opening protected settings menu

A PIN code must be entered to open the settings menu if the access security for the settings menu is enabled. Access security is enabled automatically as soon as you exit the settings menu.

- ▶ Swipe left or right until corresponding function is displayed.

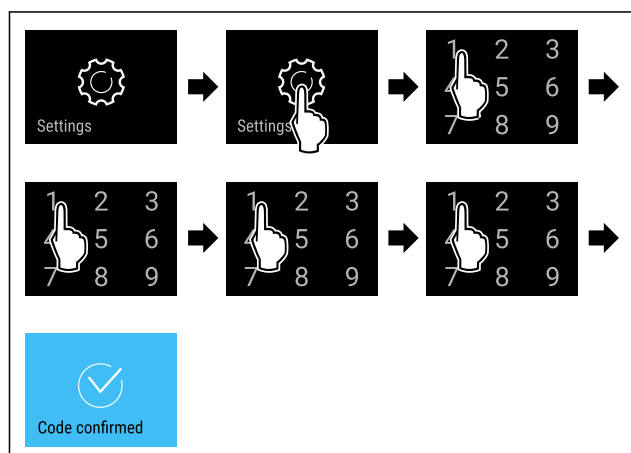

Fig. 134

- ▶ Carry out action steps according to the illustration.
- ▶ PIN code is correct: settings menu opens.

7.2.9 Access codes

There are access codes for some functions. The following functions cannot be used until the relevant access code is entered:

- Door locking
- Settings menu
- SmartLock



Door code

You can also use this function to change or reset the door code for the door lock.

Changing the door code

You change the door code in three steps:

- Enter the old door code.
- Enter the new door code.
- Confirm the new door code.

Note

In the example below, you change the factory-set door code **1 1 1 1** to the new door code **2 3 4 5**.



Fig. 135

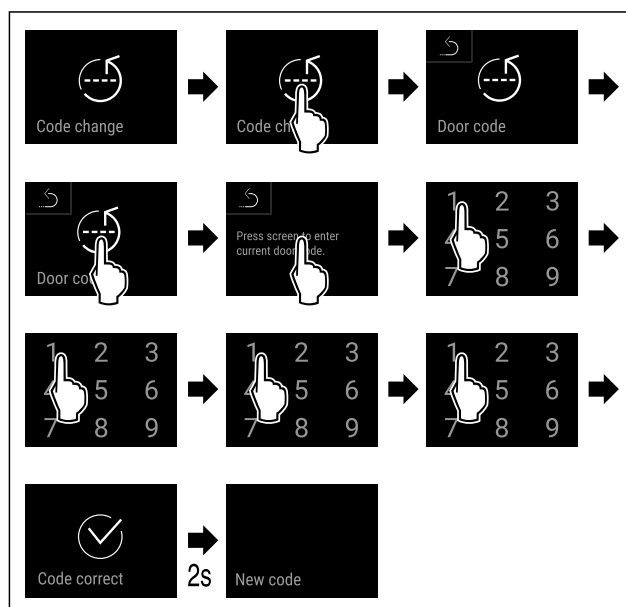

Fig. 136

- ▶ Carry out action steps according to the illustration.
- ▶ Old door code was successfully entered.

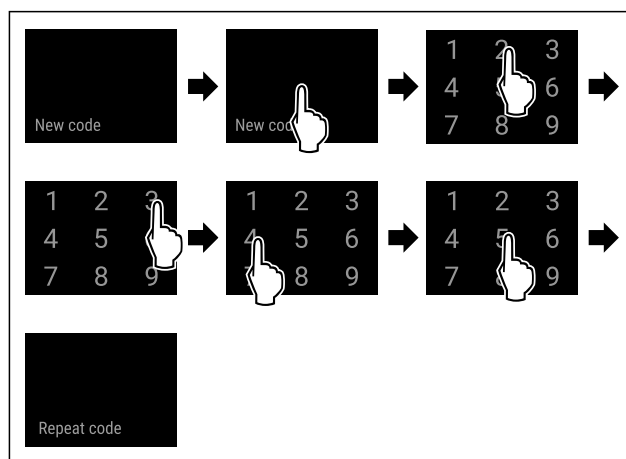

Fig. 137

- ▶ Carry out action steps according to the illustration.
- ▶ New door code was successfully entered.

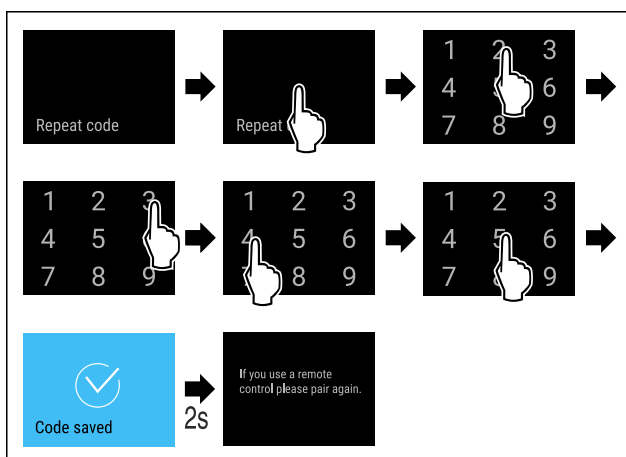

Fig. 138

Use

- ▶ Carry out action steps according to the illustration.
- ▶ New door code was successfully confirmed.
- ▶ Door code has been changed.

Resetting the door code

If you have forgotten the door code, you can reset it.

- ▶ Reset the appliance to factory settings. (see 7.2.32 Resetting to factory settings)
- ▶ Appliance is reset to the original settings.
- ▶ The factory-set door code is: **1 1 1 1**



Setting menu access code

You can also use this function to change or reset the setting menu access code.

Changing the setting menu access code

You change the access code in three steps:

- Enter the old access code.
- Enter the new access code.
- Confirm the new access code.

Note

In the example below, you change the factory-set access code **1 1 1 1** to the new access code **2 3 4 5**.

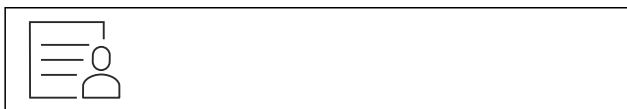

Fig. 139

The access protection of the settings menu must be activated. (see 7.2.8 Settings menu access protection)

- ▶ Swipe left or right until corresponding function is displayed.

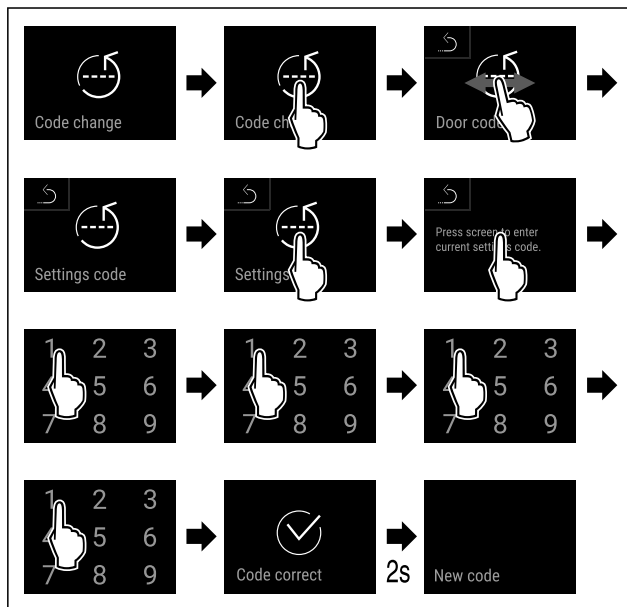

Fig. 140

- ▶ Carry out action steps according to the illustration.
- ▶ Old access code was successfully entered.

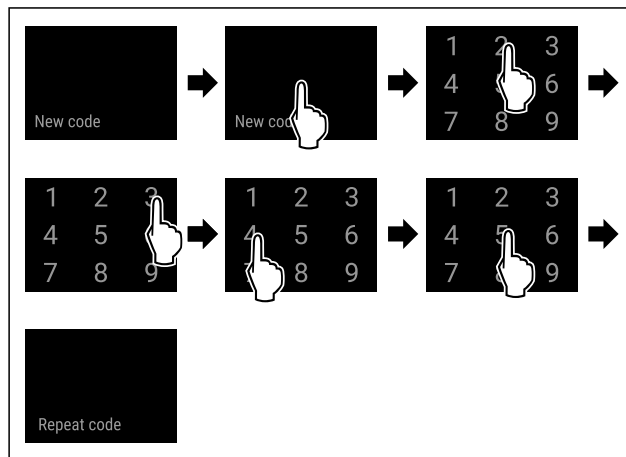

Fig. 141

- ▶ Carry out action steps according to the illustration.
- ▶ New access code was successfully entered.

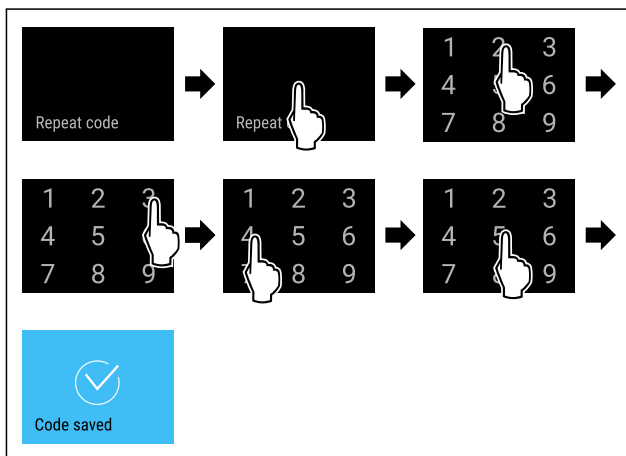

Fig. 142

- ▶ Carry out action steps according to the illustration.
- ▶ New access code was successfully confirmed.
- ▶ The access code for the setting menu has been changed.

Resetting the setting menu access code

If you have forgotten the setting menu access code, you can reset it.

- ▶ Reset the appliance to factory settings (see 7.2.32 Resetting to factory settings).
- ▶ Appliance is reset to the original settings.
- ▶ The factory-set access code is: **1 1 1 1**



SmartLock code

You can use this function to change or reset the SmartLock code.

Changing SmartLock code

You change the SmartLock-Code in three steps:

- Enter the old SmartLock code.
- Enter the new SmartLock code.
- Confirm the new SmartLock code.

Note

In the example below, you can change the factory-set SmartLock code **1 1 1 1** to the new SmartLock code **2 3 4 5**.

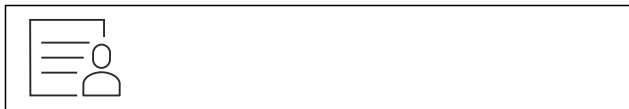

Fig. 143

SmartLock must be active. (see 7.2.7 SmartLock)

- ▶ Swipe left or right until corresponding function is displayed.

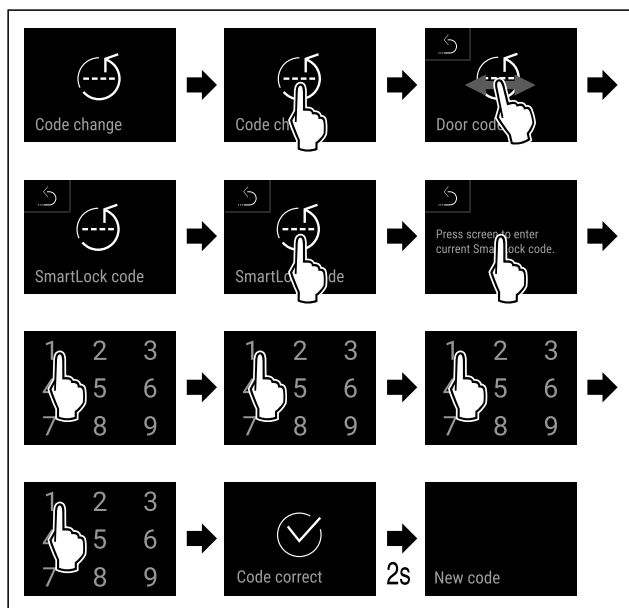

Fig. 144

- ▶ Carry out action steps according to the illustration.
- ▶ Old SmartLock code was successfully entered.

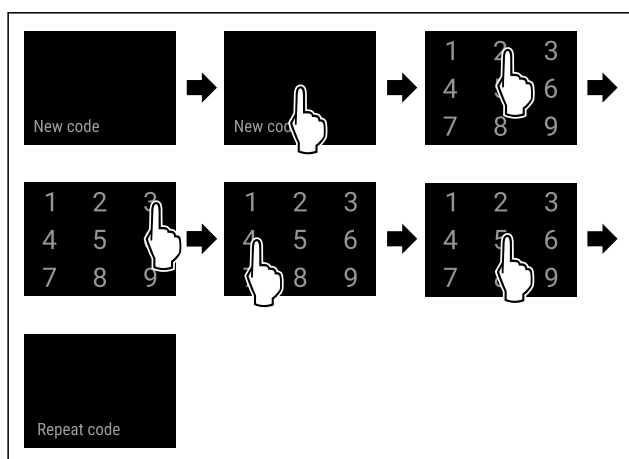

Fig. 145

- ▶ Carry out action steps according to the illustration.
- ▶ New SmartLock code was successfully entered.

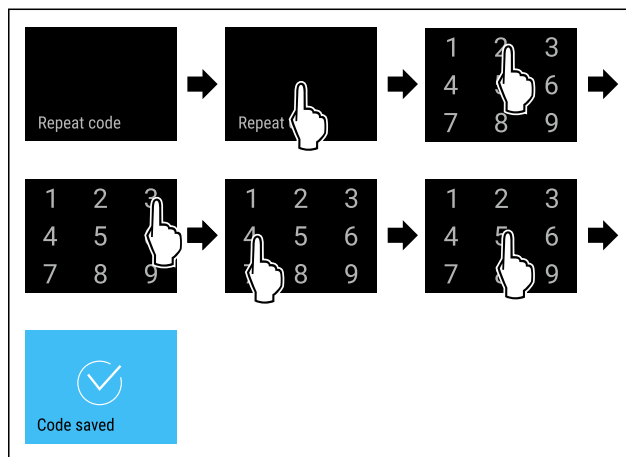

Fig. 146

- ▶ Carry out action steps according to the illustration.
- ▶ New SmartLock code was successfully confirmed.
- ▶ SmartLock code has been changed.

Resetting SmartLock code

If you have forgotten the SmartLock code, you can reset it.

- ▶ Reset appliance to factory settings.
(see 7.2.32 Resetting to factory settings)
- ▶ Appliance is reset to the original settings.
- ▶ The factory-set SmartLock code is: **1 1 1 1**

7.2.10 Maintenance interval reminder

Setting for the time interval after which a maintenance reminder is issued.

The following values can be set:

- 7 days
- 14 days
- 30 days
- 60 days
- 90 days
- 180 days
- 360 days
- 720 days
- 1080 days
- Off

Setting maintenance interval reminder

The following steps describe how the maintenance interval is set.



Fig. 147

Use

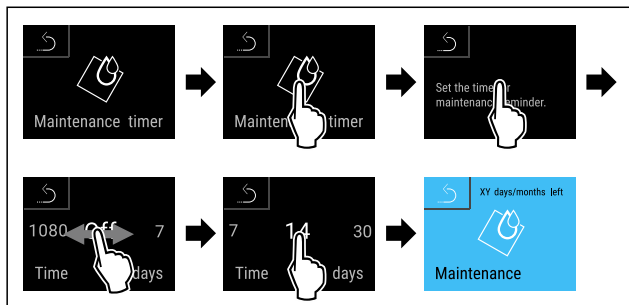

Fig. 148

- ▶ Carry out action steps according to the illustration.
- ▶ The time interval, after which the maintenance reminder is issued, is set.
- ▶ The remaining time is displayed.



7.2.11 Language

This setting allows the display language to be set.

Setting the language



Fig. 149

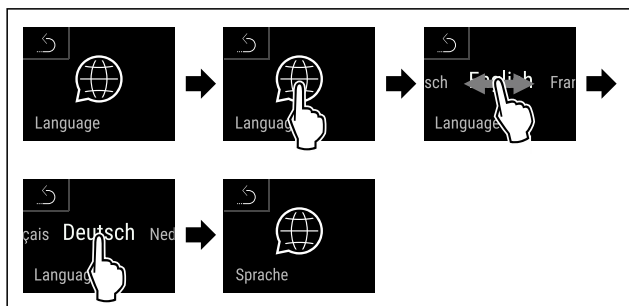

Fig. 150

- ▶ Carry out action steps according to the illustration.
- ▶ The selected language is set.



7.2.12 Date and time

This setting makes it possible to set the date and time.

Setting date and time

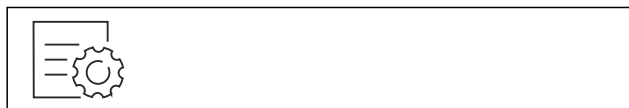

Fig. 151

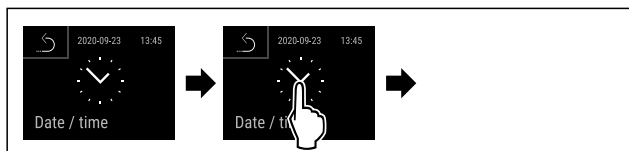

Fig. 152

- ▶ Carry out action steps according to the illustration.

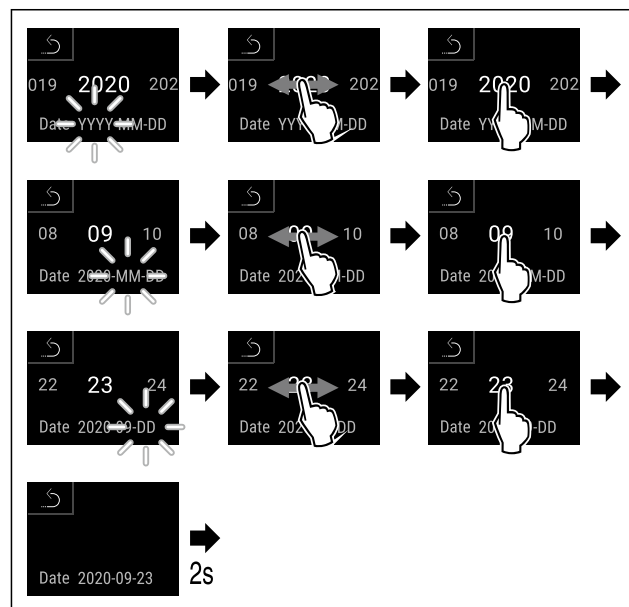

Fig. 153

- ▶ Carry out action steps according to the illustration.
- ▶ Date has been set.

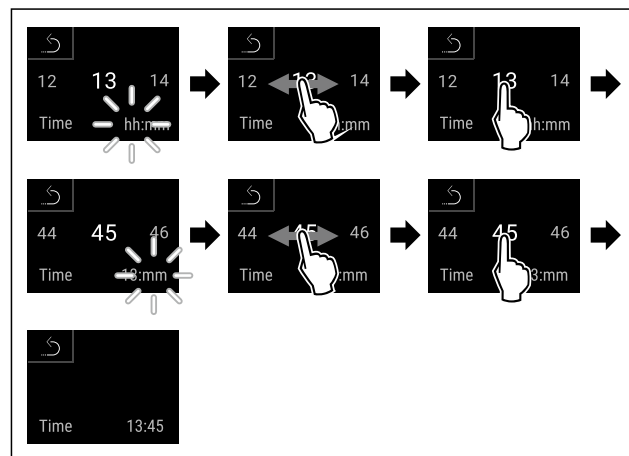

Fig. 154

- ▶ Carry out action steps according to the illustration.
- ▶ Time has been set.



7.2.13 Temperature unit

Use this function to set the temperature unit. You can set the temperature unit in either degrees Celsius or degrees Fahrenheit.

Setting the temperature unit

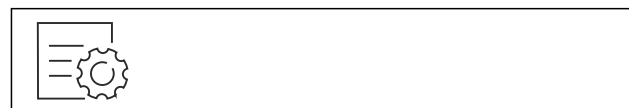

Fig. 155

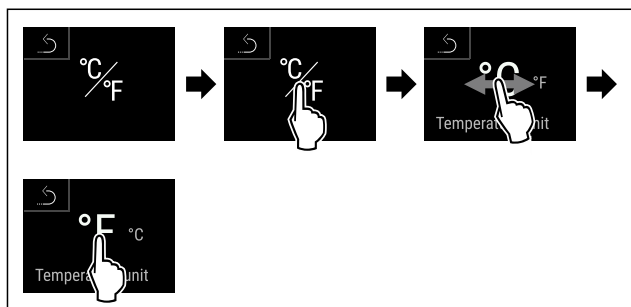

Fig. 157 Example illustration: Switching between degrees Celsius or degrees Fahrenheit.

- ▶ Carry out action steps according to the illustration.
- ▶ Temperature unit is set.

7.2.14 Display Brightness



Use this function to set the brightness of the display gradually.

You can set the following brightness levels:

- 40 %
- 60 %
- 80 %
- 100% (default setting)

Setting the brightness



Fig. 158

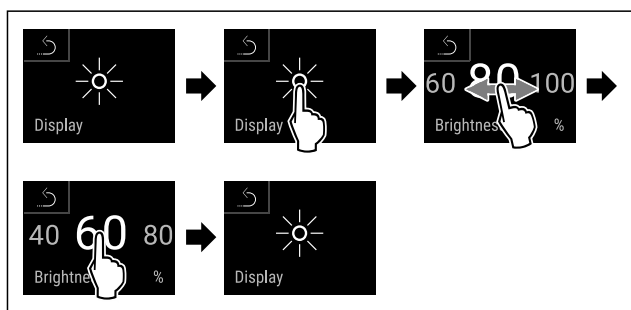

Fig. 159 Example illustration: Switching from 80% to 60%.

- ▶ Carry out action steps according to the illustration.
- ▶ Brightness is set.

7.2.15 Alarm tone



This function enables all alarm sounds, such as the door alarm, to be switched on and off.

Activating the alarm tone



Fig. 160



Fig. 161

- ▶ Carry out action steps according to the illustration.
- ▶ Alarm tone is activated.

Deactivating the alarm tone



Fig. 162

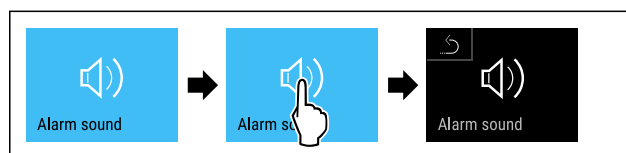

Fig. 163

- ▶ Carry out action steps according to the illustration.
- ▶ Alarm tone is deactivated.

7.2.16 Beep



This function makes it possible to switch all button sounds, confirmation sounds, and the startup sound on and off.

Activating the beep

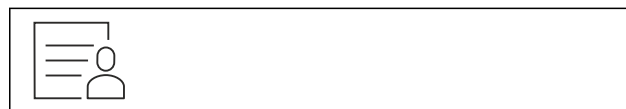

Fig. 164

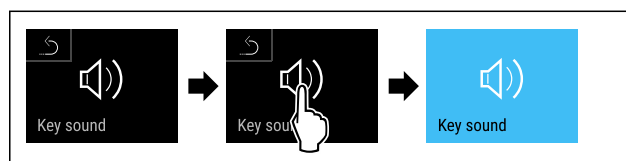

Fig. 165

- ▶ Carry out action steps according to the illustration.
- ▶ Beep is activated.

Deactivating the beep



Fig. 166

Use

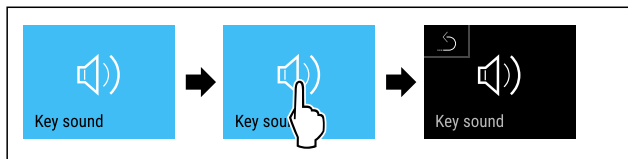

Fig. 167

- ▶ Carry out action steps according to the illustration.
- ▷ Beep is deactivated.



7.2.17 WiFi connection

Note

Liebherr SmartMonitoring Dashboard is not available in all countries. Check availability via the QR code by entering your model.

Note

Use of the Liebherr SmartMonitoring Dashboard at <https://smartmonitoring.liebherr.com> requires installation of a SmartModule and a commercial MyLiebherr account. When commissioning online you can register using your login data, or register again and create a company account.

This setting establishes a wireless connection between the appliance and the internet. The connection is controlled via the SmartModule. The appliance can be integrated via the browser-based [Liebherr SmartMonitoring Dashboard](#) and advanced options and customized methods relating to control, administration and monitoring can be used.

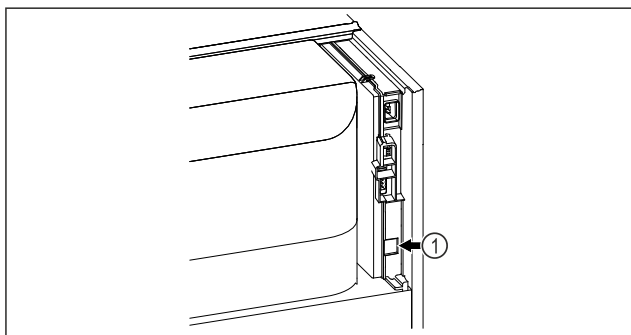

Fig. 168

Make sure that the following requirements are fulfilled:

- SmartModule Fig. 168 (1) is in use.

Establishing a connection

You commission and set up your SmartModule online via the [Liebherr SmartMonitoring Dashboard](#) on your web-enabled device.



Fig. 169

- ▶ Open [Liebherr SmartMonitoring Dashboard](#). (see Fig. 169)

On the fridge or freezer:



Fig. 170

Note

The settings menu access protection is activated. (see 7.2.8 Settings menu access protection)

- ▶ Enter the chosen PIN code. The settings menu opens.



Fig. 171

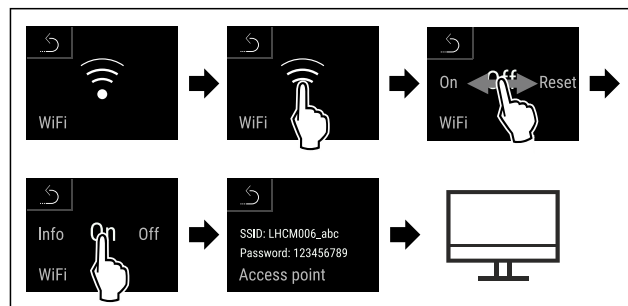

Fig. 172

- ▶ Carry out action steps according to the illustration.
- ▶ Continue the set-up procedure on your web-enabled device: [Liebherr SmartMonitoring Dashboard](#)

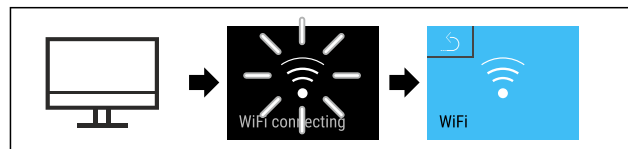

Fig. 173

- ▶ Carry out action steps according to the illustration.
- ▷ Connection is established: WiFi connecting appears. The symbol flashes.
- ▶ Follow the [Liebherr SmartMonitoring Dashboard](#) instructions.
- ▷ Connection is established.

Disconnecting

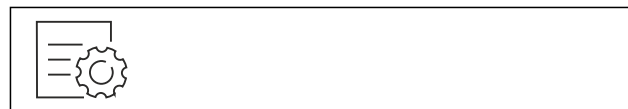

Fig. 174

Note

The settings menu access protection is activated. (see 7.2.8 Settings menu access protection)

- ▶ Enter the chosen PIN code. The settings menu opens.



Fig. 175

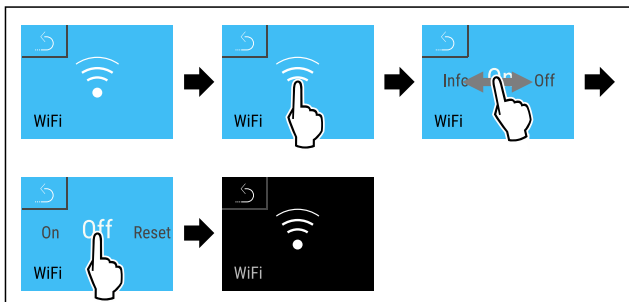

Fig. 176

- ▶ Carry out action steps according to the illustration.
- ▶ There is no connection.

Resetting connection



Fig. 177

Note

The settings menu access protection is activated. (see 7.2.8 Settings menu access protection)

- ▶ Enter the chosen PIN code. The settings menu opens.

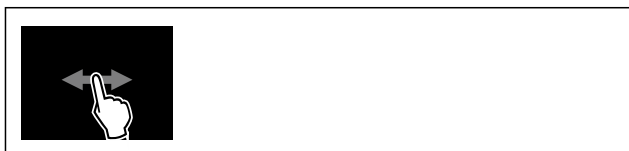

Fig. 178

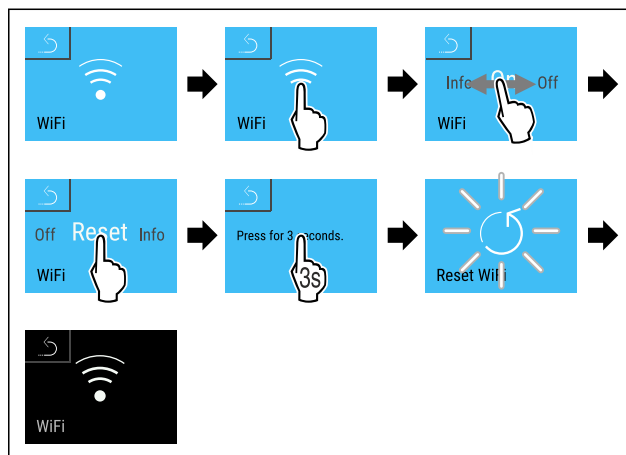
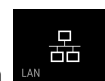

Fig. 179

- ▶ Carry out action steps according to the illustration.
- ▶ The WiFi settings are restored to the factory settings.

7.2.18 LAN connection



Note

Liebherr SmartMonitoring Dashboard is not available in all countries. Check availability via the QR code by entering your model.

Note

Use of the Liebherr SmartMonitoring Dashboard at <https://smartmonitoring.liebherr.com> requires installation of a SmartModule and a commercial MyLiebherr account. When commissioning online you can register using your login data, or register again and create a company account.

This setting establishes a wired connection between the appliance and the internet. The connection is controlled via the SmartModule. The appliance can be integrated via the browser-based [Liebherr SmartMonitoring Dashboard](#) and advanced options and customized methods relating to control, administration and monitoring can be used.

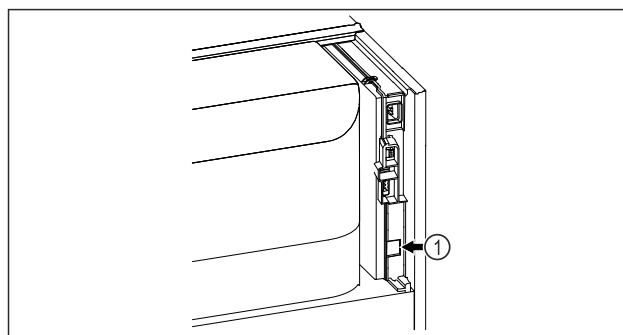

Fig. 180

Use

Make sure that the following requirements are fulfilled:

- ❑ SmartModule Fig. 180 (1) is in use.
- ❑ A network cable is connected.
- ❑ The network is connected to the Internet.

Establishing a connection

You commission and set up your SmartModule online via the [Liebherr SmartMonitoring Dashboard](#) on your web-enabled device.



Fig. 181

- ▶ Open [Liebherr SmartMonitoring Dashboard](#). (see Fig. 181)

On the fridge or freezer:

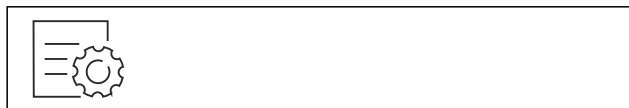

Fig. 182

Note

The settings menu access protection is activated. (see 7.2.8 Settings menu access protection)

- ▶ Enter the chosen PIN code. The settings menu opens.

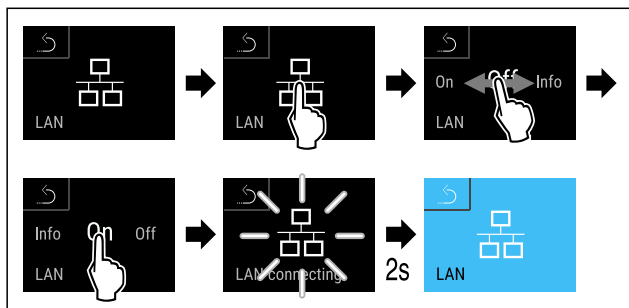

Fig. 183

- ▶ Carry out action steps according to the illustration.
- ▶ Connection is established: LAN connecting appears. The symbol flashes.
- ▶ Follow the [Liebherr SmartMonitoring Dashboard](#) instructions.
- ▶ Connection is established.

Disconnecting



Fig. 184

Note

The settings menu access protection is activated. (see 7.2.8 Settings menu access protection)

- ▶ Enter the chosen PIN code. The settings menu opens.

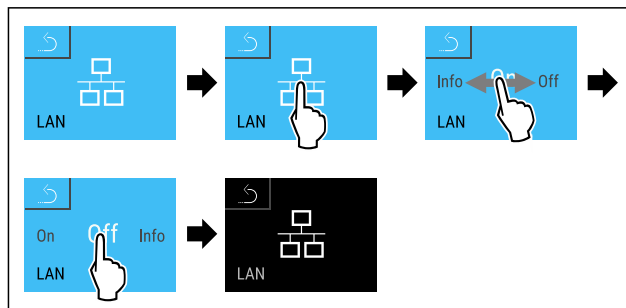

Fig. 185

- ▶ Carry out action steps according to the illustration.
- ▶ There is no connection.

7.2.19 Appliance information

Use this function to display the model name, index, serial number and service number of your appliance. You will need the appliance information when you contact customer service. (see 10.4 Customer Service) You also use this function to open the expanded menu. (see 4 Functionality of the Touch & Swipe display)



Display appliance information



Fig. 186



Fig. 187

- ▶ Carry out action steps according to the illustration.
- ▶ Display shows the appliance information.

7.2.20 Operating hours

The display shows the appliance operating hours.



Displaying operating hours



Fig. 188



Fig. 189

▶ The operating hours appear.



7.2.21 Software

Use this function to display the software version of your appliance.

Display software version



Fig. 190



Fig. 191

▶ Carry out action steps according to the illustration.
▶ Display indicates the software version.



7.2.22 Defrosting

The appliance defrosts automatically in normal operation.

Application:

- If heavier icing occurs inside the appliance, you can start the automatic defrosting function manually.

Starting automatic defrost manually

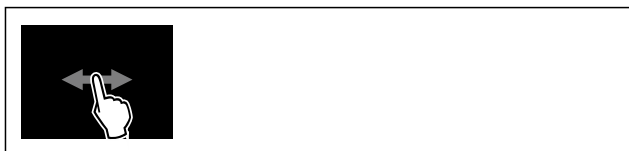

Fig. 192

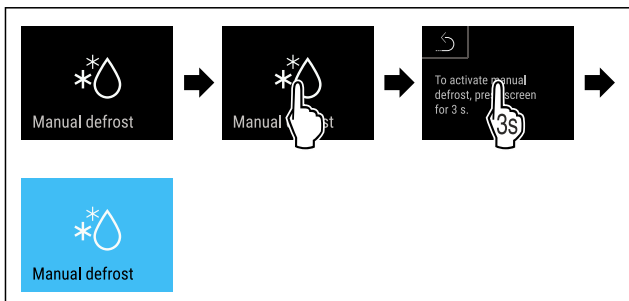

Fig. 193

- ▶ Carry out action steps according to the illustration.
- ▶ Automatic defrost has started. After defrost is complete, the appliance switches back to normal operation again.

Note

If there is still ice in the interior after several automatic defrost starts, defrost the appliance manually. (see 9.2 Defrosting the appliance)

Canceling manually started defrost



Fig. 194

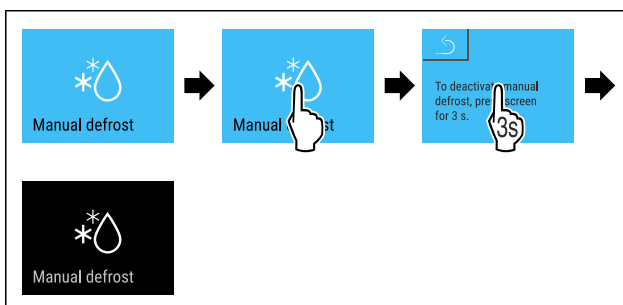

Fig. 195

- ▶ Carry out action steps according to the illustration.
- ▶ Manually started defrost is canceled. The appliance switches back to normal operation again.



Defrost info

The display during the automatic defrosting is adjusted with this setting.

Display	Description
Def 1	The temperature display is not updated. It shows the last temperature before automatic defrost was started.
Def 2	The “automatic defrosting” symbol is displayed on the status display. The temperature display is continuously updated and shows the actual temperature.
Def 3	As of software version PW SW less than TOD 8-800: The temperature display is not updated. It shows the last temperature before automatic defrost was started.
	As of software version PW SW equal or more than TOD 8-800: The temperature display is continuously updated and shows the actual temperature.

Display	Description	
Def 4	As of software version PW SW less than TOD 8-800:	The temperature display is not updated. It shows the last temperature before automatic defrost was started.
	As of software version PW SW equal or more than TOD 8-800:	The “automatic defrosting” note is displayed on the status display. The temperature display is not updated. It shows the last temperature before automatic defrost was started.



Note for “automatic defrosting” is shown in the status display



Here, you see the software version installed on your appliance PW SW: (see 7.2.21 Software)



Fig. 196

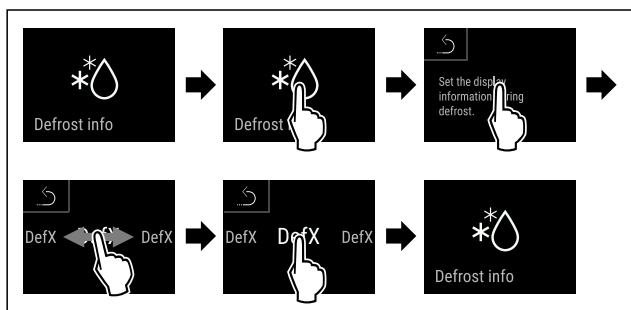

Fig. 197

- ▶ Carry out action steps according to the illustration.
- ▶ The display variant you want is selected.

7.2.23 Data download (data backup)



Use this function to activate the data backup on the appliance to a USB stick. The appliance automatically records the entire temperature progression of different sensors and also the alarm and maintenance messages. After switching on the appliance, the recording starts automatically. The appliance records 5 years of data at one-minute intervals.

Once data backup is activated, you can choose which data you want to save to the USB stick:

- Temperature log (Temperature_Log_000)
- Event log (Event_Log_000)

- Service information (Service_Info)
- All

The data backup includes the entire recording duration. The stored text files are unencrypted and feature the file extension „.log“.

More information about the stored text files:	(see 10.3 Data recording)
---	---------------------------

Activate data backup on the USB stick

Make sure that the following requirements are fulfilled:

- The USB stick is FAT32 formatted.
- The USB stick is connected. The appliance does not detect any USB hard drives.



Fig. 198

Note

Do not remove the USB stick during while data is backing up.

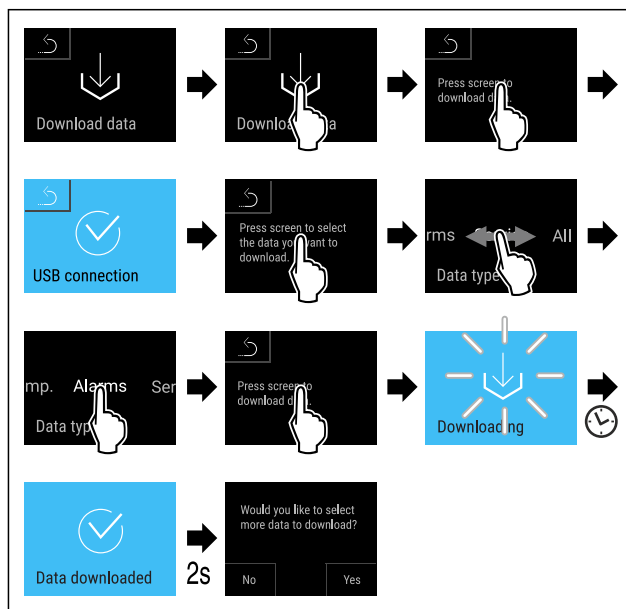

Fig. 199

- ▶ Carry out action steps according to the illustration.
- ▶ Data backup on the USB stick successful: You can select more data and back it up on the USB stick.

7.2.24 Sensor calibration



The sensor calibration allows you to offset differences between the set and the actual temperature. To do so, determine the actual temperature using a calibrated measuring gauge.

Setting range for C sensor (control sensor): +/- 3 Kelvin in 0.1 Kelvin increments.

Setting range for P sensor (product sensor): +/- 9.9 Kelvin in 0.1 Kelvin increments

Calibrating sensor



Fig. 200

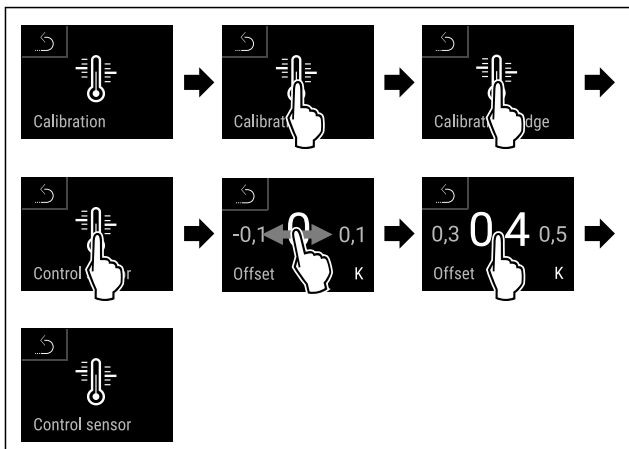

Fig. 201

- ▶ Carry out action steps according to the illustration.
- ▶ C sensor has been calibrated.

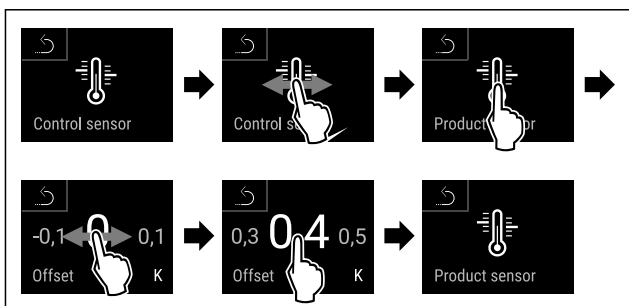

Fig. 202

- ▶ Carry out action steps according to the illustration.
- ▶ P sensor has been calibrated.
- ▶ Sensor calibration has been completed.

Note

The calibrated temperature is shown on the display within two hours.

For example		Differential value to be set
Current interior temperature	5 °C 41 °F	
Lower temperature limit	2 °C 36 °F	-3 °C 27 °F
Upper temperature limit	8 °C 46 °F	+3 °C 37 °F

You can set the following values:

- Differential value for lower temperature limit in 0.1 °C (°F) intervals
- Differential value for upper temperature limit in 0.1 °C (°F) intervals
- Alarm delay time from 0 to 60 minutes (a setting of “0” does not mean there is a delay in the temperature alarm.)
- Repetition frequency of the alarm from 0 to 30 minutes after confirming the alarm (setting of “0” means no repeated alarm after confirming the alarm relay.)

Setting temperature alarm



Fig. 203

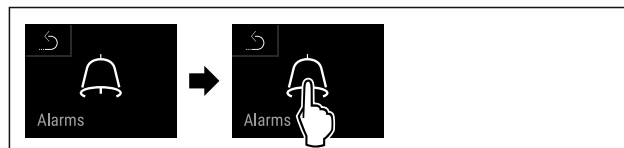

Fig. 204

- ▶ Carry out action steps according to the illustration.

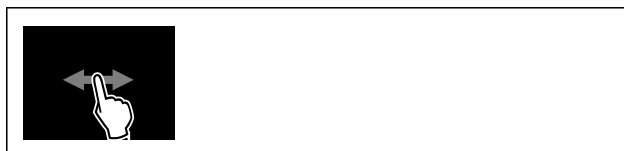

Fig. 205

7.2.25 Temperature alarm



Set the temperature alarm with this function. In the process, define the upper and lower temperature limit with a differential value to the currently set interior temperature. The temperature alarm is triggered once the interior temperature leaves the set temperature range and any set delay time has expired.

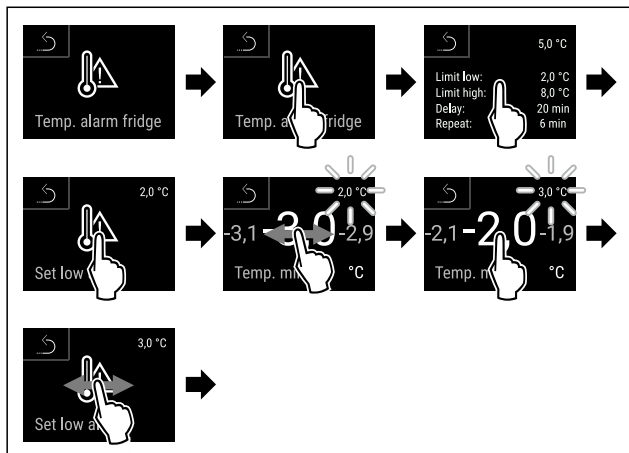

Fig. 206 Example for setting the lower temperature limit based on a set appliance temperature of 5 °C.

- ▶ Carry out action steps according to the illustration.
- ▶ Lower temperature limit has been set.

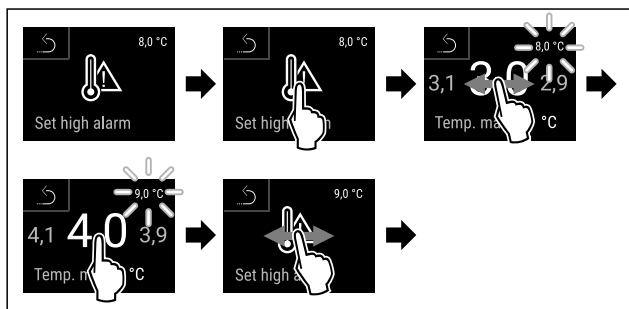

Fig. 207 Example for setting the upper temperature limit based on a set appliance temperature of 5 °C.

- ▶ Carry out action steps according to the illustration.
- ▶ Upper temperature limit has been set.

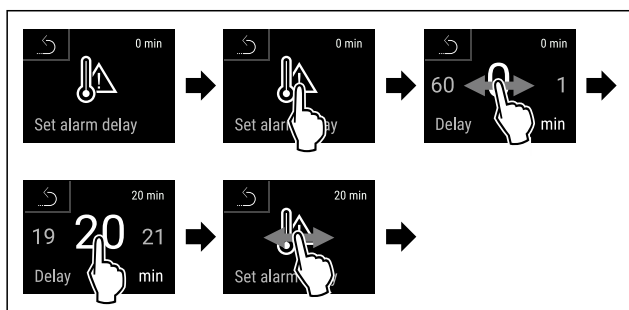

Fig. 208

- ▶ Carry out action steps according to the illustration.
- ▶ Alarm delay time has been set.

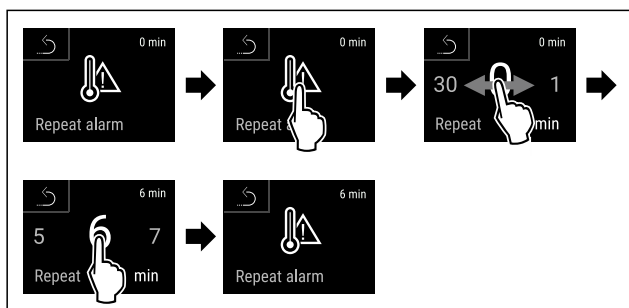

Fig. 209

- ▶ Carry out action steps according to the illustration.
- ▶ Alarm repetition interval has been set.
- ▶ Temperature alarm has been set.

Displaying set temperature alarm values



Fig. 210



Fig. 211

- ▶ Carry out action steps according to the illustration.



Fig. 212

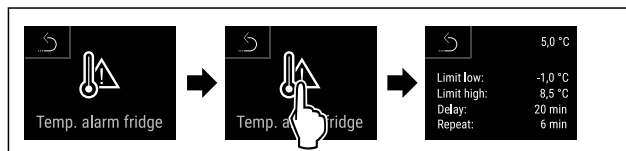

Fig. 213

- ▶ Carry out action steps according to the illustration.
- ▶ Set temperature alarm values are displayed.

7.2.26 Door alarm



Use this function to activate or deactivate the door alarm. The door alarm sounds if the door is open for too long. The door alarm is activated upon delivery. You can set how long to door can remain open until the door alarm sounds.

You can set the following values:

- 15 seconds
- 30 seconds
- 60 seconds
- 90 seconds
- 120 seconds
- 150 seconds
- 180 seconds
- Off

Setting the door alarm



Fig. 214

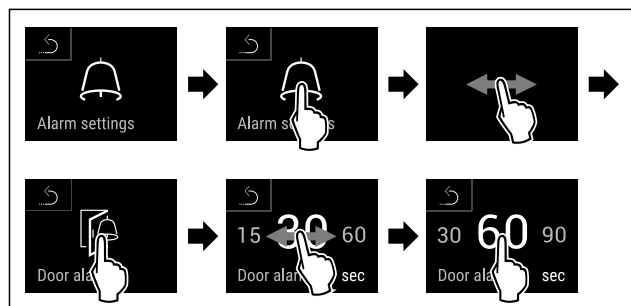

Fig. 216 Example illustration: Changing the door alarm from 30 seconds to 60 seconds.

- ▶ Carry out action steps according to the illustration.
- ▶ Door alarm is set.

Deactivating door alarm



Fig. 217

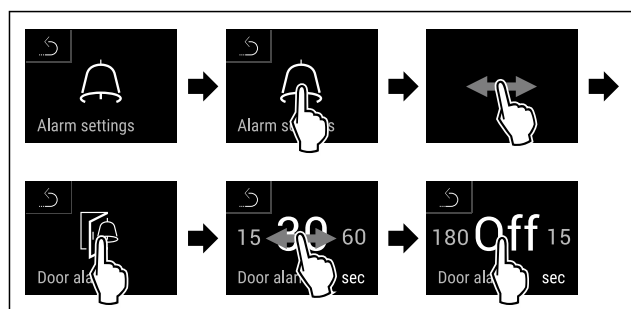

Fig. 218

- ▶ Carry out action steps according to the illustration.
- ▶ Door alarm is deactivated.

7.2.27 Light alarm



This setting allows the visual alarm messages in the display to also be emphasized by flashing appliance lighting.

Activating the light alarm



Fig. 219

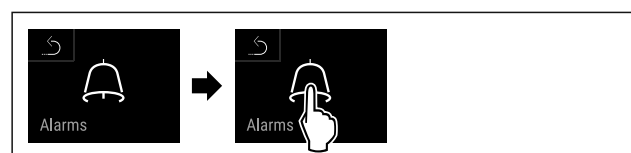

Fig. 220

- ▶ Carry out action steps according to the illustration.

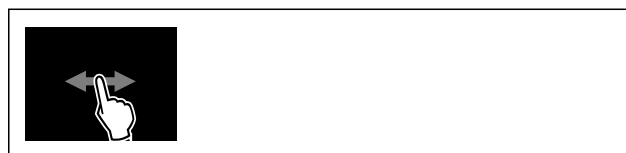

Fig. 221

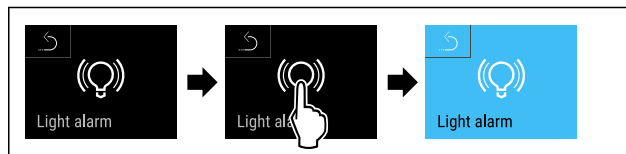

Fig. 222

- ▶ Carry out action steps according to the illustration.
- ▶ The light alarm is activated.

Deactivating the light alarm

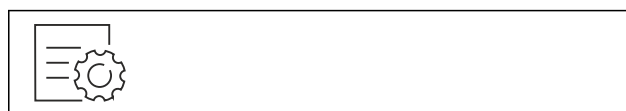

Fig. 223

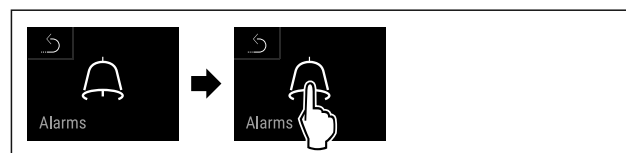

Fig. 224

- ▶ Carry out action steps according to the illustration.



Fig. 225

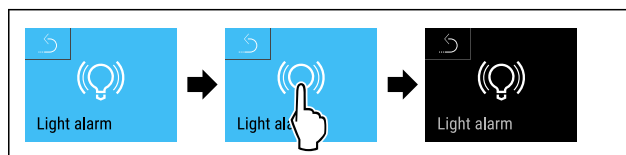

Fig. 226

- ▶ Carry out action steps according to the illustration.
- ▶ The light alarm is deactivated.

7.2.28 Alarm simulation



This function enables you to simulate a temperature alarm in the appliance, e.g. to check whether one of the safety devices triggers correctly. The safety device is connected to the potential-free alarm output. (see 8.4 Interfaces)

Use

Starting the alarm simulation



Fig. 227



Fig. 228

- ▶ Carry out action steps according to the illustration.



Fig. 229

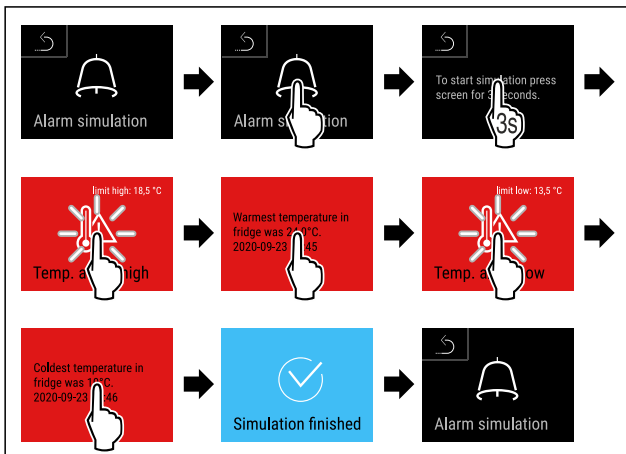
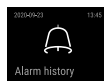

Fig. 230

- ▶ Carry out action steps according to the illustration.
- ▶ The simulation has been performed.
- ▶ Connected safety devices should have triggered.

7.2.29 Alarm log



This setting makes it possible to query and delete the last 10 alarms that have occurred on the device.

The following is displayed:

- Current date and time
- Active alarms (red).
- Past alarms, which have not yet been queried, are shown as **unconfirmed (red)**. Confirmation is given by swiping to the next error.
- Alarms, which have been queried, are shown as **confirmed**.
- Deletion of all alarms (including active and unconfirmed alarms).

Displaying alarm log and deleting an alarm



Fig. 231

-or-

- ▶ Via the display symbol at the bottom edge of the status display.

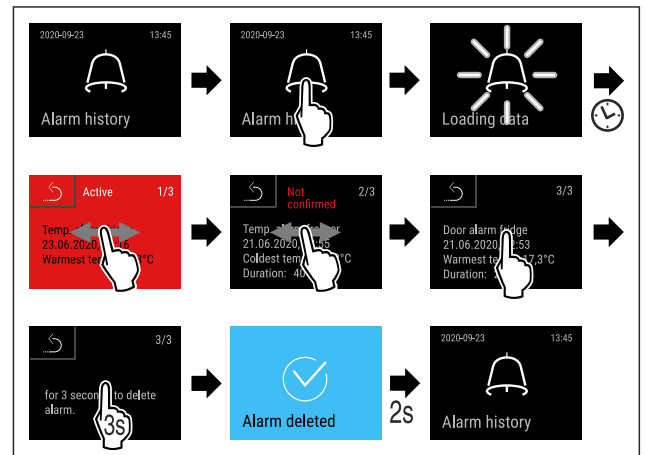

Fig. 232

- ▶ Carry out action steps according to the illustration.
- ▶ The querying and deletion of an alarm has been performed.

Displaying alarm log and deleting all alarms



Fig. 233

-or-

- ▶ Via the display symbol at the bottom edge of the status display.

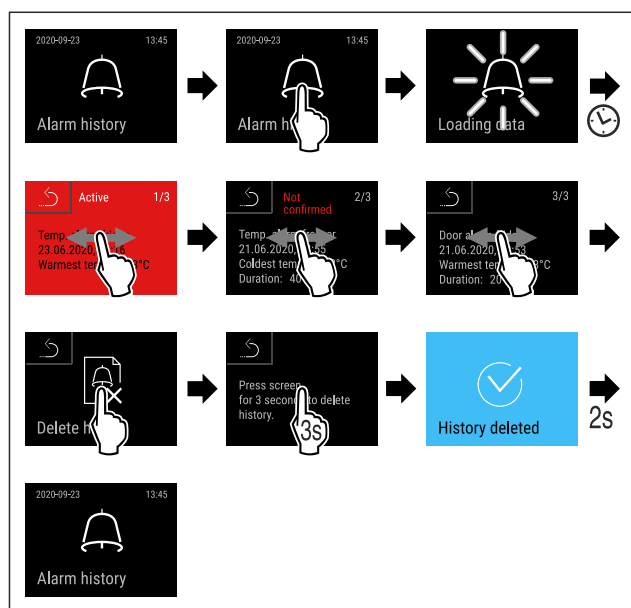

Fig. 234

- ▶ Carry out action steps according to the illustration.
- ▶ The querying and deletion of all alarms has been performed.



7.2.30 Alarm forwarding

This function enables you to set to have one or several alarms to be forwarded to an external alarm receiver. Here, the alarm receiver is connected to the appliance's potential-free alarm output. (see 8.4 Interfaces)

You can select from the following settings:

- Alarm type:
 - Door alarm
 - Temperature alarm
 - Door alarm and temperature alarm
 - All
- Confirm:
 - **Yes:** The alarm is confirmed on the appliance and the externally connected receiver.
 - **No:** The alarm is confirmed on the appliance and remains active on the receiver until the error is remedied.
- Update (only visible if you have selected “Yes” when you confirmed):
 - **Yes:** Alarm repeats.
 - Temperature alarm** depending on the set time (see 7.2.25 Temperature alarm) (If you set the delay time of the alarm to “0”, there will be no alarm repetition at the alarm relay either.)
 - Door alarm** after 1 or 4 minutes* (see 7.2.26 Door alarm)
 - **No:** Alarm permanently confirmed.

Activating alarm forwarding



Fig. 235

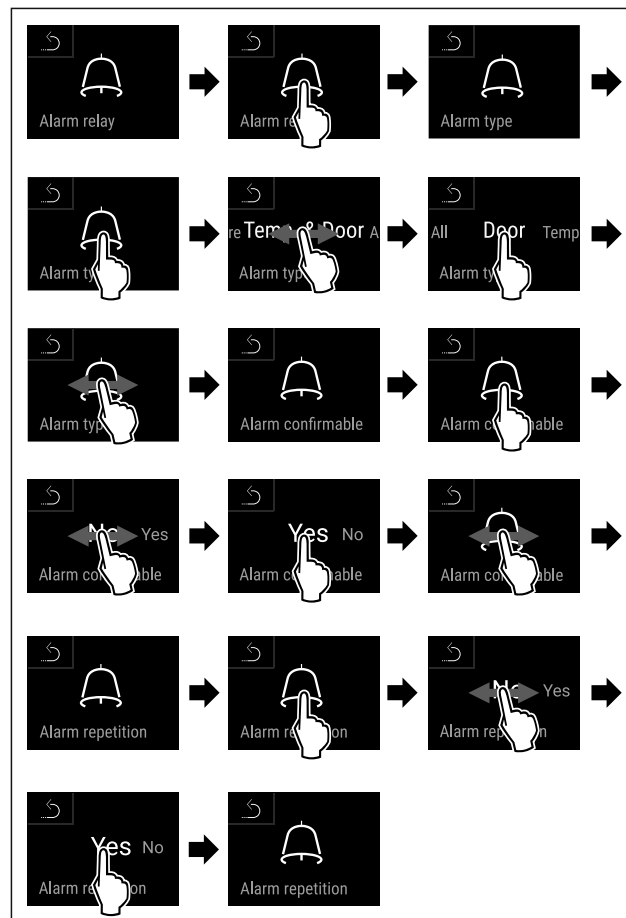
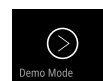

Fig. 236

- ▶ Carry out action steps according to the illustration.
- ▶ Alarm forwarding is set.



7.2.31 Demo mode

Demo mode is a special feature for dealers who want to demonstrate appliance features. If you activate demo mode, all refrigeration functions are deactivated. If you switch on your appliance and a “D” appears on the status display, demo mode is already activated. If you activate and then deactivate demo mode, the appliance will be reset to factory defaults. (see 7.2.32 Resetting to factory settings)

Activating demo mode



Fig. 237

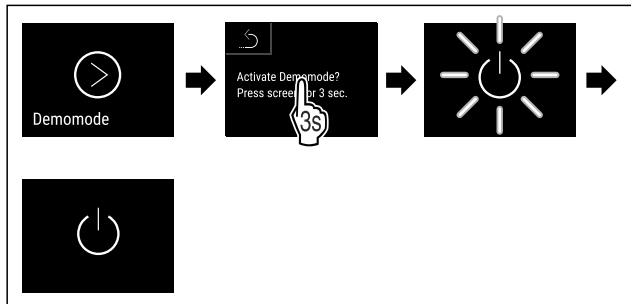

Fig. 238

- ▶ Carry out action steps according to the illustration.
- ▶ Demo mode is activated.
- ▶ Appliance is switched off.
- ▶ Switch on the appliance. (see 5.1 Switching on the appliance (first use))
- ▶ “D” appears in the status display.

Deactivating demo mode



Fig. 239

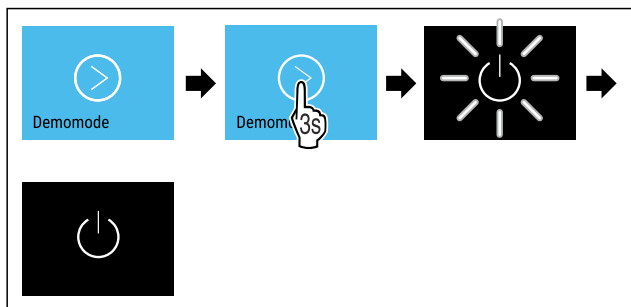

Fig. 240

- ▶ Carry out action steps according to the illustration.
- ▶ Demo mode is deactivated.
- ▶ Appliance is switched off.
- ▶ Switch on the appliance. (see 5.1 Switching on the appliance (first use))
- ▶ Appliance is reset to factory settings.

7.2.32 Resetting to factory settings



Use this function to reset all settings to factory settings. All settings you have made so far are reset to their original settings.

Performing a reset



Fig. 241

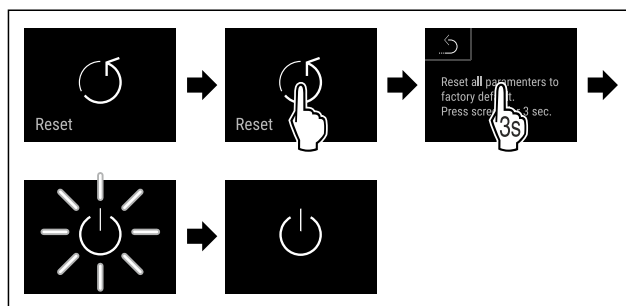

Fig. 242

- ▶ Carry out action steps according to the illustration.
- ▶ Appliance is reset.
- ▶ Appliance is switched off.

Note

Resetting to factory settings in battery mode: A restart is only possible with mains voltage.







- ▶ Restart the appliance. (see 5.1 Switching on the appliance (first use))

7.3 Messages



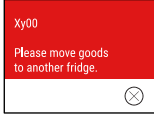

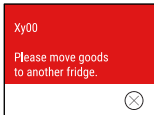

7.3.1 Warnings

Warnings are issued by means of an audio signal and visually via a symbol on the display. The signal gets louder until the warning is acknowledged.

Message (red)	Cause	Remedy
<p>Door open</p>	The message appears if the door is open for too long.	Close the door. Tap briefly. Alarm is stopped. Note The time until the message appears can be set. (see 7.2.26 Door alarm)





Message (red)	Cause	Remedy
 <p>Temperature alarm</p> <p>Temperature alarm</p>	<p>This message appears if the temperature does not match the set temperature. Reasons for differences in temperature can be:</p> <p>Warm produce for cooling has been placed inside.</p> <p>Too much warm room air has flowed in during the rearrangement and removal of food.</p> <p>The power was cut off for a prolonged period.</p>	<p>Tap briefly.</p> <p>Information about errors and appliance status are displayed.</p> <p>Tap briefly.</p> <p>Warmest/coldest temperature, date and time are displayed.</p> <p>Tap briefly.</p> <p>The status screen is displayed.</p> <p>The current temperature and the alarm symbol flash red until the set temperature is reached.</p> <p>Check the quality of the refrigerated goods.</p>
 <p>Device failure</p> <p>Error</p>	<p>The appliance is malfunctioning, there is an appliance error or a component of the appliance has a fault.</p>	<p>Store refrigerated items elsewhere.</p> <p>Tap briefly.</p> <p>The error code (e.g. BT021) is displayed.</p>  <p>Tap briefly.</p> <p>A further error code is displayed if there is one</p> <p>or</p> <p>Status screen is displayed with flashing error symbol.</p>  <p>Swiping or tapping the display will show the error code(s) again.</p> <p>Make a note of error code(s) and contact Customer Service. (see 10.4 Customer Service)</p>
	<p>The message indicates that freeze protection mode is active (e.g. due to frequent door openings or loading with goods).</p>	<p>Tap briefly.</p> <p>FRZ.PROT is displayed.</p>  <p>Tap briefly.</p> <p>Status screen is displayed with flashing error symbol.</p>  <p>Swiping or tapping the display will show the message again.</p> <p>The appliance automatically switches to normal operating mode after a few hours and the message disappears. Alternatively, the mode and message can be ended with a long tap. If the message is displayed repeatedly and the causes listed do not apply, contact customer service. (see 10.4 Customer Service)</p>

Use

Message (red)	Cause	Remedy
 <p>Power failure</p> <p>Power failure</p>	<p>The message appears following an interruption to the electricity supply. The operating panel continues running in battery mode. All functions remain active except for refrigeration and lighting.</p>	<p>Tap briefly.</p> <p>Battery's state of charge, information about errors and appliance status are displayed</p> <p>Tap briefly.</p> <p>The warmest temperature and the time when there was a power outage are displayed.</p> <p>Tap briefly.</p> <p>The status screen is displayed.</p> <p>The current temperature and the alarm symbol flash red until the set temperature is reached.</p> <p>Check the quality of the refrigerated goods.</p>
 <p>WiFi error</p> <p>WiFi error</p>	<p>WiFi connection is interrupted.</p>	<p>Check connection.</p> <p>Press briefly.</p> <p>Alarm is stopped.</p>
 <p>WWW error</p> <p>WWW error, WiFi</p>	<p>This message appears if there is no internet connection via WiFi.</p>	<p>Check connection.</p> <p>Press briefly.</p> <p>Alarm is stopped.</p>
 <p>LAN error</p> <p>LAN error</p>	<p>LAN connection is interrupted.</p>	<p>Check connection and network cable.</p> <p>Press briefly.</p> <p>Alarm is stopped.</p>
 <p>WWW error</p> <p>WWW error, LAN</p>	<p>This message appears if there is no internet connection via LAN.</p>	<p>Check connection.</p> <p>Press briefly.</p> <p>Alarm is stopped.</p>
 <p>Battery status</p> <p>Battery error</p>	<p>Low appliance battery level (max. 20% remaining).</p>	<p>Reconnect the appliance to a power supply and check whether the battery charge level has increased after 12 hours. Otherwise contact Customer Service (see 10.4 Customer Service) or replace the battery. (see 9.4 Replacing appliance battery)</p> <p>Press briefly.</p> <p>Alarm is stopped.</p>

7.3.2 Reminders

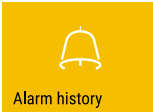
Reminders appear when you are prompted to take action. They are issued by means of an audio signal and visually via a symbol on the display. Acknowledge the message by pressing the confirmation button.

Message (yellow)	Cause	Remedy
 <p>Maintenance</p> <p>Maintenance reminder</p>	The message appears when the timer for the set maintenance interval has expired.	Press briefly. Reminder is closed. Note The maintenance interval can be set (see 7.2.10 Maintenance interval reminder).
 <p>Min./max. memory</p> <p>Logging reminder</p>	The message appears if the temperature recording memory (999 hours) is full.	Press briefly. Reminder is closed. The oldest data is overwritten. Note The temperature recording can be reset. (see 7.2.4 Temperature recording)
 <p>Alarm history</p> <p>Alarm log</p>	The message appears if there are more than 10 unconfirmed alarm messages.	Press briefly. Check messages. Reminder is closed.
 <p>Manually opened</p> <p>Manually opened</p>	This message appears if a door which has been locked electronically is manually opened.	Close the door. Press briefly. Reminder is closed.

8 Equipment

8.1 Safety lock

The appliance door is fitted with an electronic lock.

Application:

- Lock and unlock with the door code. (see 7.2.6 Door lock)
- Activate and deactivate automatic locking. (see 7.2.6 Door lock)
- The door locks automatically after a power outage (cannot be deactivated).

8.1.1 Emergency release

You can open the door can with the emergency release key if there is a power failure.

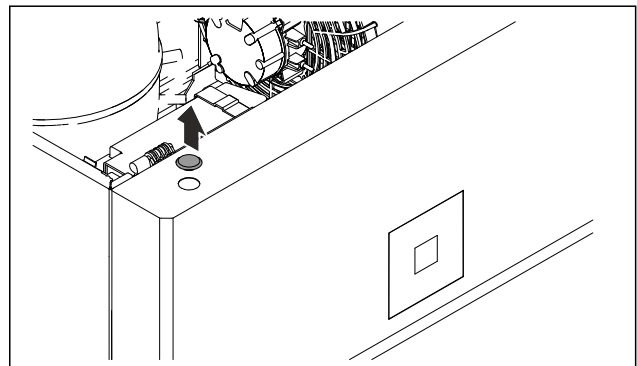

Fig. 243

- Remove the cover.

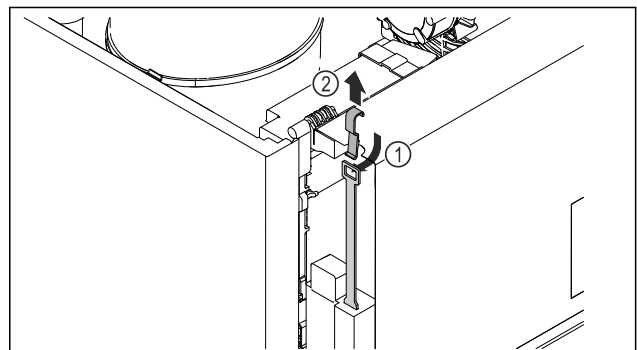

Fig. 244

- Push the emergency release key Fig. 244 (1) in from the top, hook it into the lock, and pull up Fig. 244 (2).

Equipment

► The lock is released. You can open the door.

8.2 Sensors

The appliance can be equipped with the following sensors for temperature monitoring:

- Safety thermostat sensor
- C sensor
- P sensor

8.2.1 Safety thermostat sensor

The safety thermostat sensor monitors the temperature drop and thus protects against excessively low temperatures (Freeze Protect). If the temperature drops below the threshold value, the appliance regulates the temperature automatically. The error message FRZ. PROT (Freeze Protect) (see 7.3 Messages) appears.

Note

Do not cover the safety thermostat sensor.

8.2.2 C sensor (control sensor)

The C sensor is permanently installed and regulates the interior temperature of the appliance. You can calibrate the C sensor if necessary. (see 7.2.24 Sensor calibration)

8.2.3 P sensor (product sensor)

You can position the P sensor in any location in the interior, in order to record and monitor the temperature in this location specifically. If the set temperature is exceeded in this location, the sensor triggers an alarm. You can calibrate the P sensor if necessary. (see 7.2.24 Sensor calibration)

Note

Accessories are available from the Liebherr Service Center. The address for your respective country can be found on the back of the instructions.



8.3 Sensor info

This function makes it possible to choose between C sensor or P sensor.

Make sure that the following requirement is met:

- P sensor is connected to the appliance. (see 8.4 Interfaces)

8.3.1 Selecting C sensor

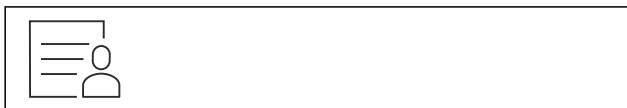

Fig. 245

► Swipe left or right until corresponding function is displayed.

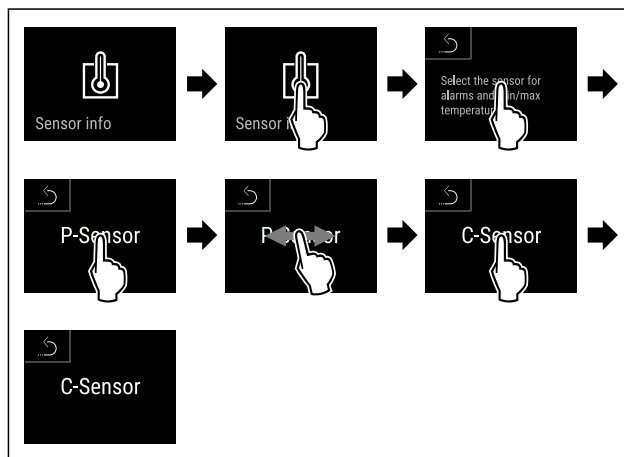

Fig. 246

► Carry out action steps according to the illustration.
 ► C sensor has been selected.

8.3.2 Selecting P sensor



Fig. 247

► Swipe left or right until corresponding function is displayed.

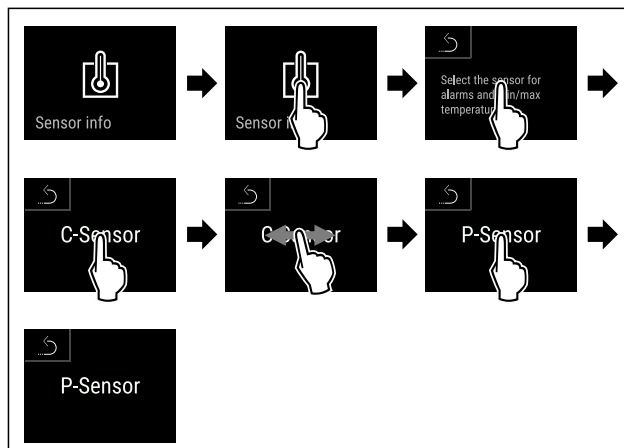

Fig. 248

► Carry out action steps according to the illustration.
 ► P sensor has been selected.

8.4 Interfaces

There are various connection options on the back of the appliance.

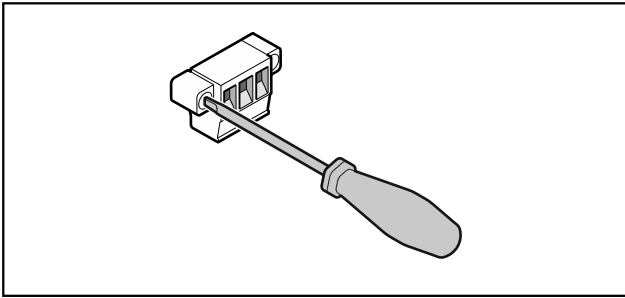

Fig. 249

Note

Screws secure the plugs. To enable disconnection of the plugs, loosen the screws on the left and right.

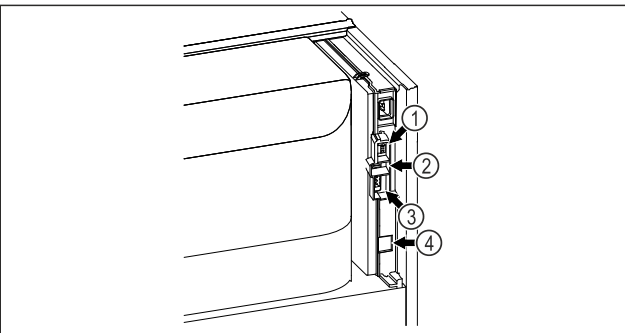

Fig. 250

- | | |
|-----------------------------|---------------------------------|
| (4) Connection for P sensor | (3) Potential-free alarm output |
| (2) USB interface | (4) LAN interface |

8.4.1 Potential-free alarm output

! WARNING

Risk of injury due to electric shock!

- The appliance may only be connected to an external alarm device by trained specialist personnel.

These three contacts can be used to connect a visual or an acoustic alarm device. The connection is designed for a maximum of **30 V (DC) - 8 A** from a safety low voltage source SELV (**minimum current 150 mA**).

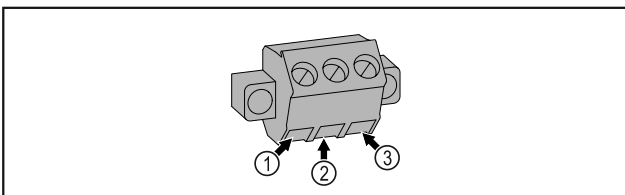

Fig. 251

- (1) NO (normally open)
Connection for indicator lamp, which is active in normal operation or when the appliance is switched off.
- (2) COM (common)
External voltage source

- (3) NC (normally closed)
Connection for alarm lamp or audible alarms, which is active when an alarm is triggered or lack of power supply.

8.4.2 Connection for P sensor

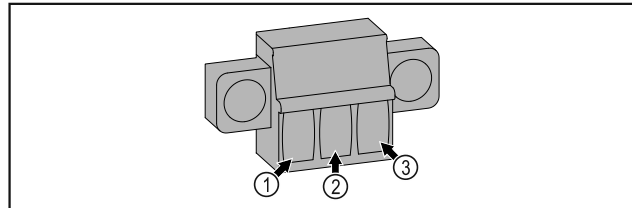

Fig. 252

- (1) IN+ (measuring line +)
- (2) IN- (common return line -)
- (3) FORCE (supply +)

9 Maintenance

9.1 Maintenance schedule

Maintenance work is to be performed at regular intervals to ensure proper appliance function.

! CAUTION

Danger of injury and damage due to unprofessional maintenance work!

Personal injury and material damage.

- Maintenance work may only be performed by trained specialist personnel.

! WARNING

Short-circuit hazard due to live parts!

Electric shock or damage to the electronics.

- **Switch off the appliance.**
- Pull out mains plug or switch off fuse.

Note

A maintenance reminder function can be activated. (see 7.2.10 Maintenance interval reminder)

Note

We recommend creating a maintenance log in which all work (repairs, checks) performed is documented.

Maintenance

Note

Liebherr recommends yearly maintenance. For an individual offer, please contact Customer Service (see 10.4 Customer Service) .

Component	Activity	Maintenance interval
Sheet metal parts	Check for damage and corrosion. Replace damaged parts: (see 10.4 Customer Service)	Yearly
Door, hinges	Check alignment (see 3.6 Aligning the door) , ease of movement, and tight fit.	Yearly
Lock, door handle *	Check for ease of movement and tight fit.	Yearly
Door seal	Check for damage, wear, and tight fit. A replacement door gasket is available via Customer Service (see 10.4 Customer Service) .	Yearly
Sensor	Calibrate sensor. (see 7.2.24 Sensor calibration)	Yearly
Sensor feedthrough	Check that the sealing compound is intact.	Yearly
Battery	Replace appliance battery. A replacement battery is available from customer service. (see 9.4 Replacing appliance battery)	5 to 10 years
Surfaces	Cleaning (see 9.3 Cleaning the appliance)	Recommendation: monthly or as required/specified at installation location
Surfaces	Disinfection Liebherr has tested the following disinfectants: Dismozon pur 1 % Lösung (Bode Chemie), Suma Quicksan (Diversey), Incidin Extra N (Ecolab Healthcare), Acrylan (Antiseptica chem.-pharm. Produkte), Buraton 10 F (Schülke und Mayr), Frankocid N (Franken Chemie), Apesin DSR 50 (Tana), Nüscosept Spray (Dr. Nüsken), Melsept SF (B. Braun Melsungen), Kohrsolin (Bode Chemie), Neoquat S (Dr. Weigert), Indicin Rapid (Ecolab Healthcare), Bacillocid Spezial (Bode Chemie), Neoform K Spray (Dr. Weigert), Apesin Desinf. Spray (Tana), Nüscosept 100 (Dr. Nüsken), Antisept T (Fink Tec), Apesin AP 100 0,50% Lösung (Tana), Perform Pulver 2% Lösung (Schülke und Mayr) Observe the operating instructions of the respective manufacturer. If disinfectants other than those stated are used, test them on a less exposed area first.	Recommendation: monthly or as required/specified at installation location

Component	Activity	Maintenance interval
Installation location, appliance	Decontamination The appliance is suitable for room decontamination with hydrogen peroxide H ₂ O ₂ . In this context, the values of the following application specifications must not be exceeded: Concentration: maximum 250 ppm. Humidity: maximum 85%. Maximum permissible room temperature as per climate class. (see 2.4 Range of appliance use)	Recommendation: as required/specified at installation location, maximum 2x per year
Fan air slots	Cleaning	Yearly
Alarm relay	Check plug connections for tight fit.	Yearly
Sensor	Check the plug connections for a tight fit.	Annually
Network cable	Check for damage.	Annually or when changing the location
Tilting angle	Check the functional capability and for a tight fit.	Annually or when changing the location
Adjustable feet / rollers	Check the functional capability, for damage and a tight fit. Replace any damaged parts. (see 10.4 Customer Service)	Annually

9.2 Defrosting the appliance



WARNING

Appliance incorrectly defrosted!
Injuries and damage.

- ▶ Do not use mechanical devices or other means to accelerate the defrosting process, other than those recommended by the manufacturer.
- ▶ Do not use any electrical heating or steam cleaning equipment, naked flames or defrosting sprays.
- ▶ Do not remove ice with sharp objects.

Defrosting is performed automatically. The water from the defrosting process runs out via the drain opening and is evaporated.

To maintain the functionality of the appliance, we recommend defrosting it when there is a high buildup of ice. Icing in the interior is determined by the location (e.g. high humidity), settings on the appliance and incorrect user behavior.

If the automatic defrost cycle is not sufficient:

- ▶ Start the automatic defrost manually.
(see 7.2.22 Defrosting)

If the problem persists, defrost the appliance manually:

- ▶ Switch off appliance. (see 7.2.2 Switching appliance on and off)
- ▶ Disconnect power plug.
- ▶ Store refrigerated items elsewhere.

- ▶ Leave the appliance door open during defrosting process.
- ▶ Soak up remaining defrost water with a cloth, clean the drain opening and the appliance.

9.3 Cleaning the appliance

9.3.1 Preparing



WARNING

Short-circuit hazard due to live parts!
Electric shock or damage to the electronics.

- ▶ **Switch off the appliance.**
- ▶ Pull out mains plug or switch off fuse.



WARNING

Danger of fire
▶ Do not damage the refrigerant circuit.

- ▶ Empty the appliance.
- ▶ Pull out the power plug.
- ▶ Observe the notes on appliance transport.

Maintenance

9.3.2 Cleaning the housing

NOTICE

Improper cleaning!
Damage to the appliance.

- ▶ Only use soft cleaning cloths and ph-neutral all-purpose cleaners.
- ▶ Do not use steel wool or sponges that scour or scratch.
- ▶ Do not use caustic or abrasive cleaning materials or those containing sand, chloride, or acids.



WARNING

Risk of injury or damage due to hot steam.
Hot steam can cause scalding/burns and damage to surfaces.

- ▶ Do not use steam cleaners.

NOTICE

Risk of damage due to short circuit.

- ▶ When cleaning the appliance, make sure no water gets into the electrical components.
- ▶ Wipe the housing down with soft, clean cloth. If very dirty, use lukewarm water with a neutral cleaner. Glass surfaces can also be cleaned with glass cleaner.
- ▶ Clean the condenser coil every year. If the condenser coil is not cleaned, this significantly reduces the efficiency of the appliance.

9.3.3 Cleaning the dust filter

The dust filter is on the top of the appliance. Clean the dust filter at least twice a year.

- ▶ Disconnect the power plug.

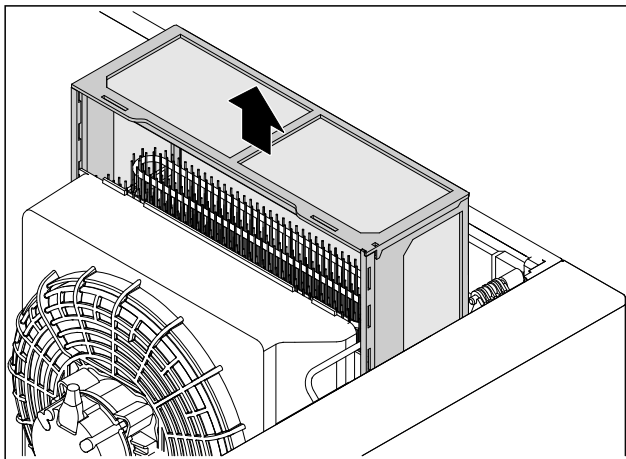

Fig. 253

- ▶ Pull out the dust filter upward.
- ▶ Clean the dust filter with water and dishwashing detergent.
- ▶ Insert the dust filter.

9.3.4 Cleaning the interior



WARNING

Short-circuit hazard due to live parts!
Electric shock or damage to the electronics.

- ▶ **Switch off the appliance.**
- ▶ Pull out mains plug or switch off fuse.



WARNING

Risk of injury or damage due to hot steam.
Hot steam can cause scalding/burns and damage to surfaces.

- ▶ Do not use steam cleaners.

NOTICE

Improper cleaning!
Damage to the appliance.

- ▶ Only use soft cleaning cloths and ph-neutral all-purpose cleaners.
- ▶ Do not use steel wool or sponges that scour or scratch.
- ▶ Do not use caustic or abrasive cleaning materials or those containing sand, chloride, or acids.

Note

- ▶ Defrost water drain (see 2.2 Overview of appliances and equipment) : Remove deposits using a thin object (e.g. a cotton bud).

Note

Do not damage or remove the type plate on the inside of the appliance. The type plate is important for Customer Service. (see 10.4 Customer Service)

- ▶ Open the door.
- ▶ Empty the appliance.
- ▶ Clean the interior and equipment parts with lukewarm water and a little dish detergent. Do not use any gritty or acidic cleaning agent or any chemical solvent.

9.3.5 After cleaning

- ▶ Wipe the appliance and equipment parts dry.
- ▶ Connect and switch on appliance.
When the temperature is sufficiently cold:
- ▶ Place in items for refrigeration.
- ▶ Clean regularly.
- ▶ Clean the refrigeration machine with heat exchanger and remove dust from it once a year.

9.4 Replacing appliance battery

In the event of a power failure, the appliance battery is used to record temperature history, alarm and service messages and to show the alarm messages on the display for approximately 12 hours. During initial commissioning, the battery may take up to 24 hours to charge and be in proper working order.

A replacement battery is available from customer service (see 10.4 Customer Service).

9.4.1 Replacing the battery



WARNING

Short-circuit hazard due to live parts!
Electric shock or damage to the electronics.

- ▶ **Switch off the appliance.**
- ▶ Pull out mains plug or switch off fuse.

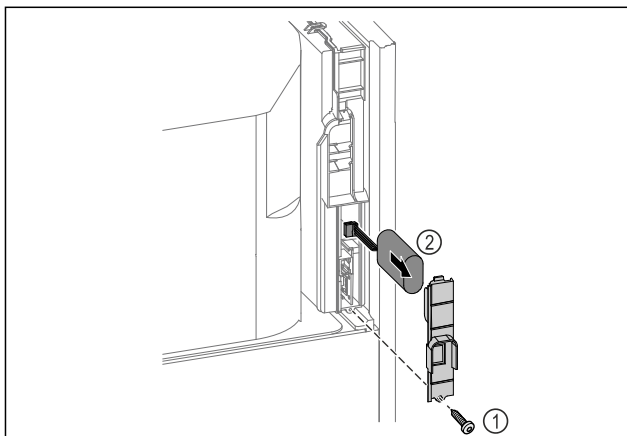

Fig. 254

- ▶ Unscrew screw and remove cover from the back of the appliance Fig. 254 (1).
- ▶ Disconnect the battery and remove it Fig. 254 (2).
- ▶ Install replacement battery.
- ▶ Close the cover and screw in the screw.
- ▶ Reconnect mains power cable.

Note

- ▶ The battery must be sent for separate waste treatment and disposed of properly and professionally in accordance with the locally applicable regulations and laws. **Do not damage or short circuit the battery!**

10 Customer support

10.1 Technical data

Temperature range	
Cooling	Foamed door:* -2 °C (28 °F) to +16 °C (60 °F)* Glass door:* 0 °C (32 °F) to +16 °C (60 °F)*

Maximum load of grid shelves ^{A)}	Maximum load of center grid shelf ^{A)} (see 5.2 Using equipment)
60 kg (132 lb)	10 kg (22.05 lb)

^{A)} Heavier loads may result in a slight bending of the shelves.

Net capacity
See net capacity on the type plate. (see 2.2 Overview of appliances and equipment)

Lighting	
Energy efficiency class ^{A)}	Light sources
This product contains one or more energy efficiency class G light sources	LED

^{A)} The appliance may contain light sources with different energy efficiency classes. The lowest energy efficiency class is indicated.

WLAN frequency specification	
Frequency band	2.4 GHz
Maximum radiated power	<100 mW
Purpose of the wireless equipment	Integration in the local WiFi network for data communication

Setup conditions	
Degrees of pollution (surrounding the appliance)	PD2
Ambient temperature	+10 °C (50 °F) to +35 °C (95 °F)
Maximum relative ambient moisture	75%, not condensing
Maximum operating elevation (meters above sea level)	2000 m (6,561.68 ft) 1500 m (4,921.26 ft) (glass door)*

Electrical values	
Nominal voltage	115-127 V ~

Customer support

Electrical values	
Frequency	60 Hz
Connected load	4,0 A
Maximum power supply fluctuation	+/-10%
Overvoltage categories	II

Data according to DIN 13277 measured at a reference ambient temperature of +25 °C (77 °F)				
Model SRPvh	Energy consumption (kWh/24h)	Temperature increase in case of a power failure (min)	Temperature homogeneity (°K)	Temperature constancy (°K)
1402	1.227	126 A)	0.7 B)	1.1 B)
1412	1.944	90 A)	1.0 B)	1.0 B)
6501	0.487	101 A)	1.0 B)	1.7 B)
6511	0.850	89 A)	1.2 B)	2.1 B)
8401	0.596	125 A)	0.7 B)	1.4 B)
8411	1.006	96 A)	1.0 B)	1.5 B)

A) Heating of the reference unit: from +5 °C (41 °F) to +10 °C (50 °F) / reference unit: 50 ml (1.69 oz) glass container filled with 25 ml (0.85 oz) of isopropanol and 25 ml (0.85 oz) of water

B) Measured at a reference nominal temperature of +5 °C (41 °F)

Appliance battery	
Type	1S2P/NCR 18650BF
Nominal voltage	3.6 V DC
Capacity	6.7 Ah

10.2 Technical malfunction

Your appliance is designed and built to ensure it works reliably and has a long service life. If a malfunction nonetheless occurs during operation, please check whether the malfunction is due to an operating error. If this is the case, you will be charged for the cost incurred even if this falls within the warranty period. You can rectify the following malfunctions yourself.

10.2.1 Appliance function

Defect	Cause	Remedy
The appliance is not working.	The appliance is not switched on.	▶ Switch on the appliance.
	The power plug is not properly inserted in the socket.	▶ Check the power plug.
	There is a problem with the wall socket breaker.	▶ Check the breaker.
	Power failure	▶ Keep the appliance closed. ▶ The door can be opened with the emergency release key. (see 8.1 Safety lock) ▶ If necessary move the refrigerated/frozen items to another fridge or freezer if the power is off for a prolonged period.
	The IEC socket is not correctly plugged into the appliance.	▶ Check the IEC socket.
The temperature is not cold enough.	The appliance door is not closed properly.	▶ Close the appliance door.
	Ventilation is not sufficient.	▶ Unclog the ventilation grill and clean it.
	The ambient temperature is too high.	▶ Observe the suitable ambient conditions: (see 2.4 Range of appliance use)
	The appliance was opened too many times or for too long.	▶ Wait to see if the required temperature corrects itself. If not, contact Customer Service. (see 10.4 Customer Service)

Defect	Cause	Remedy
	The temperature is set incorrectly.	▶ Set a colder temperature and check after 24 hours.
	The appliance is too close to a heat source (stove, heater etc).	▶ Move either the appliance or the heat source.

10.3 Data recording

Once you have completed a data backup on a USB stick on the appliance (see 7.2.23 Data download (data backup)), you can analyze the stored text files.

The following files are stored on the USB stick after the data backup:

Event_Log_*.log	Event log
Temperature_Log_*.log	Temperature log
Service_Info.log	This file is only intended for customer service.
Download_Info.txt	This file contains information about the appliance and the checksums of the downloaded files.

The files Event_Log_*.log and Temperature_Log_*.log are numbered consecutively after a predefined file size has been reached (000, 001, 002, etc.).

Log file Event_Log_*.log and Temperature_Log_*.log:

① | ② | ③
 ID;yyyy-mm-ddThh:mm:ss+00:00;Event Id;Additional Data

Fig. 255 Example illustration

(1) Consecutive numbering **(3)** Data fields

(2) Date and time (UTC)

The individual values are separated by semicolons (;).

Data fields Event_Log_*.log:

Event Id; Additional Data
 (see 10.3.1 Event log → Event_Log_*.log)

Data fields Temperature_Log_*.log:

Control Sensor Zone 0; Product Sensor Zone 0; Safety-Device Sensor Zone 0; Evaporator Zone 0; Control Sensor Zone 1; Evaporator Zone 1; Ambient
 (see 10.3.2 Temperature log → Temperature_Log_*.log)

10.3.1 Event log → Event_Log_*.log

10.3.1 A

Event Id	Additional Data		
A = Alarm	0 = The door alarm warns the user if they keep the door open for too long or forget to close it.	0 to 3 = The zone in which the event occurred.	0 = Off 1 = On 2 = Confirmed
A = Alarm	6 = The appliance checks periodically whether all sensors are working properly. Otherwise, emergency mode and the alarm are triggered.	0 to 3 = The zone in which the event occurred.	0 = Off 1 = On 2 = Confirmed
A = Alarm	12 = The power failure alarm warns the user after a power failure that the appliance became too warm during the power failure.	0 to 3 = The zone in which the event occurred.	0 = Off 1 = On 2 = Confirmed
A = Alarm	13 = The power failure alarm warns the user after a power failure that the appliance became too cold during the power failure.	0 to 3 = The zone in which the event occurred.	0 = Off 1 = On 2 = Confirmed

Customer support

Event Id	Additional Data		
A = Alarm	45 = The temperature alarm is activated when the displayed temperature leaves the upper temperature range for the configured time.	0 to 3 = The zone in which the event occurred.	0 = Off 1 = On 2 = Confirmed
A = Alarm	48 = The temperature alarm is activated when the displayed temperature leaves the lower temperature range for the configured time.	0 to 3 = The zone in which the event occurred.	0 = Off 1 = On 2 = Confirmed
A = Alarm	54 = The appliance failure alarm is activated if an electronic component (sensor or actuator with feedback) has an error and the appliance failure functionality is configured.	0 to 3 = The zone in which the event occurred.	0 = Off 1 = On 2 = Confirmed
A = Alarm	127 = The warning is activated when the data logger detects a power failure in the local 13 V system.	0 to 3 = The zone in which the event occurred.	0 = Off 1 = On 2 = Confirmed

10.3.1 B

Event Id	Additional Data	
B = Data logger error	I = Info W = Warning E = Error R = Reset A = Assert	Internal event log data for customer service.

10.3.1 C

Event Id	Additional Data	
C = Compressor	0 to 3 = The zone in which the event occurred.	0 = Off 1 = On

10.3.1 DF

Event Id	Additional Data	
DF = Defrost	0 to 3 = The zone in which the event occurred.	0 = Off 1 = On

10.3.1 DL

Event Id	Additional Data	
DL = Door locking	0 to 3 = The zone in which the event occurred.	0 = Unlocked 1 = Locked 2 = Emergency opening

10.3.1 DR

Event Id	Additional Data	
DR = Door	0 to 3 = The zone in which the event occurred.	0 = Closed 1 = Open

10.3.1 R

Event Id	Additional Data	
R = Relay status	0 = Alarm relay 1 = Safety relay	0 = Closed 1 = Open

10.3.1 S

Event Id	Additional Data				
S = Changes to settings	0 = Status of a zone has changed.	0 = Zone 0 is switched off. 1 = Zone 0 is switched on. 3 = Zone 0 not available.	0 = Zone 1 is switched off. 1 = Zone 1 is switched on. 3 = Zone 1 not available.	0 = Zone 2 is switched off. 1 = Zone 2 is switched on. 3 = Zone 2 not available.	
S = Changes to settings	1 = Time and date change	Set time value in ISO format, e.g. 2020-05-20T17:02:00			
S = Changes to settings	2 = Password	1 = Smart-Lock code 2 = Display-sperre-Code	0 = Internal parameter		
S = Changes to settings	3 = Software version	1 = User Interface 127 = Power-board	0 to 255 = Major Version	0 to 255 = Minor Version	0 to 255 = Patch Version

Customer support

Event Id	Additional Data		
S = Changes to settings	4 = Temperature alarm thresholds	0 to 3 = The zone in which the event occurred.	<p>0 = eDataloggerSettingTemperatureAlarmMinAbsolute: If the temperature is above this value, the display temperature is rounded to the preset temperature.</p> <p>1 = eDataloggerSettingTemperatureAlarmMinRelativ: If the temperature is above the preset temperature minus this value, the display temperature is set to the preset temperature.</p> <p>2 = eDataloggerSettingTemperatureAlarmMaxAbsolute: If the temperature is below this value, the display temperature is rounded to the preset temperature.</p> <p>3 = eDataloggerSettingTemperatureAlarmMaxRelativ: If the temperature is below the preset temperature plus this value, the display temperature is set to the preset temperature.</p> <p>4 = eDataloggerSettingTemperatureAlarmDelayUpperTemperature: After this time, the temperature alarm is activated if the display temperature is warmer than the rounding value.</p> <p>5 = eDataloggerSettingTemperatureAlarmDelayLowerTemperature: After this time, the temperature alarm is activated if the display temperature is colder than the rounding value.</p> <p>6 = eDataloggerSettingTemperatureAlarmRepeat: After this time, the temperature alarm is activated again after it has ended. If the value is set to 0, the function is switched off.</p>
S = Changes to settings	5 = Sensors calibration offset	<p>0 = Ambient temperature sensor</p> <p>1 = Safety thermostat sensor</p> <p>2 = C sensor (control sensor) Zone 0</p> <p>3 = Evaporator temperature sensor zone 0</p> <p>4 = C sensor (control sensor) Zone 1</p> <p>5 = Evaporator temperature sensor zone 1</p> <p>6 = P sensor (product sensor)</p>	-255 to 255 = Calibration offset in Celsius
S = Changes to settings	6 = Target temperature	0 to 3 = The zone in which the event occurred.	Set temperature in degrees Celsius, e.g. 5.00
S = Changes to settings	7 = Defrost parameter	0 to 3 = The zone in which the event occurred.	0 to 65535 = Interval in minutes

Event Id	Additional Data	
S = Changes to settings	8 = Alarm forwarding	00000001 = Door alarm is displayed as an external alarm. 00000010 = Temperature alarm is displayed as an external alarm. 00000011 = Door alarm and temperature alarm are displayed as external alarms. 00000111 = Each alarm is displayed as an external alarm.

10.3.1 U

Event Id	Additional Data	
U = Data recording	0 = Data logger status	0 = Off 1 = On
U = Data recording	1 = USB command	-1 = Functional test 0 = USB stick formatting 3 = Writing temperature log 5 = Writing event log 9 = WritingService_Info.log 15 = Writing all log files
U = Data recording	2 = USB status	-8 = Power supply interrupted during the write process -7 = USB stick not compatible -6 = Power supply interrupted -5 = Formatting error -4 = USB stick removed during the write process -3 = USB stick full or write-protected -2 = USB stick not FAT32 formatted -1 = No USB stick connected 0 = Deactivated 1 = Ready 2 to 100 = Percentage progress of the executed command

10.3.2 Temperature log → Temperature_Log_*.log

The entire temperature progression of the various sensors is recorded. The recording **always** takes place in degrees Celsius.

Control sensor zone 0	Product sensor zone 0	Safety device sensor zone 0	Evaporator sensor zone 0	Control sensor zone 1	Evaporator sensor zone 1	Ambient
C sensor (control sensor) Zone 0	P sensor (product sensor) Zone 0	Safety thermostat sensor Zone 0	Evaporator sensor Zone 0	C sensor (control sensor) Zone 1	Evaporator sensor Zone 1	Ambient temperature sensor
3.89	4.10	3.69	4.00			18.81

Example for a single-zone appliance

Shutting down

Control sensor zone 0	Product sensor zone 0	Safety device sensor zone 0	Evaporator sensor zone 0	Control sensor zone 1	Evaporator sensor zone 1	Ambient
C sensor (control sensor) Zone 0	P sensor (product sensor) Zone 0	Safety thermostat sensor Zone 0	Evaporator sensor Zone 0	C sensor (control sensor) Zone 1	Evaporator sensor Zone 1	Ambient temperature sensor
3.89	4.10	3.69	4.00	-18.05	-18.21	18.81

Example for a multi-zone appliance

10.4 Customer Service

First check whether you can remedy the fault yourself. If this is not the case, please contact Customer Service.

You can find the address in the enclosed brochure "Liebherr-Service" or at home.liebherr.com/service.



WARNING

Unprofessional repair!
Injuries.

- ▶ A damaged power cable may only be replaced by the manufacturer, the manufacturer's Customer Service or a similarly qualified person.
- ▶ For appliances with plug and play connection cables, the change can be made by the customer.

10.4.1 Contacting Customer Service

Make sure you have the following appliance information ready:

- Appliance name (model and index)
 - Service no. (service)
 - Serial no. (S no.)
 - ▶ Access the appliance information via the display (see 7.2.19 Appliance information).
- or-
- ▶ Refer to the type plate for appliance information. (see 10.5 Type plate)
 - ▶ Note appliance information.
 - ▶ Inform Customer Service: Report faults and the appliance information.
 - ▶ This will help us to provide fast and focused service.
 - ▶ Follow any further instructions provided by Customer Service.

10.5 Type plate

The type plate is inside the appliance. See appliance overview.

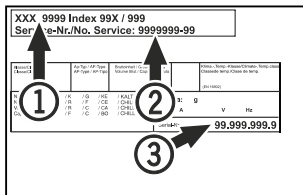

Fig. 256

- (1) Appliance designation
- (2) Service No.
- (3) Serial No.

11 Shutting down

- ▶ Empty the appliance.
- ▶ Switch off appliance.
- ▶ Pull the power plug from the outlet.
- ▶ If necessary, remove the IEC socket: Pull the IEC socket out of the appliance plug while turning it to the left and right at the same time.
- ▶ Clean the appliance. (see 9.3 Cleaning the appliance)
- ▶ If available: Remove the covers and insulation of the sensor feed-through to prevent mold from forming.
- ▶ Leave the door open so that no bad odors form.

Note

Damage to the appliance and malfunctions!

- ▶ After shutting down, only store the appliance at the permitted room temperature of between -10 °C (14 °F) and +50 °C (122 °F).

12 Disposal

12.1 Preparing the appliance for disposal



WARNING

Risk of child entrapment!

Before you throw away your old refrigerator or freezer:

- ▶ Take off the doors.
- ▶ Leave the shelves in place so that children may not easily climb inside.



Li-Ion

Liebherr uses batteries in some of its appliances. You should remove these before disposal of the old appliance for environmental reasons. If your appliance contains batteries, a corresponding notice is attached to the appliance.

Lamps

If you can remove the lamps yourself without destroying them, also remove these before disposal.

- ▶ Take the appliance out of operation.
- ▶ Appliance with batteries: Remove the batteries. For description, see **Maintenance** chapter.
- ▶ If possible: Remove lamps without destroying them.

12.2 Disposing of the appliance in an environmentally friendly manner



The appliance still contains valuable materials and must be collected separately from unsorted municipal waste so it can be recycled.



Li-Ion



Li-Ion

Dispose of batteries separately from the old appliance. Certain batteries should NOT go in household garbage or recycling bins. Waste batteries can always be recycled or taken to household hazardous waste collection points. To prevent fires from lithium-ion batteries, tape battery terminals and/or place batteries in separate plastic bags and never put these batteries in household garbage or recycling bins.

Lamps

Dispose of removed lamps via the respective collection systems.

For USA:

Check the Responsible Appliance Disposal (RAD) program to find a RAD partner near you.

For Canada:

Follow your local guidance about recycling and disposal capabilities near you.



WARNING

Leaking refrigerant and oil!

Fire. The refrigerant contained within the appliance is environmentally friendly, but flammable. The oil contained within the appliance is flammable. Escaping refrigerant and oil can ignite if they are of high enough concentration and are exposed to an external heat source.

- ▶ Do not damage the pipelines of the coolant circuit and the compressor.
- ▶ Observe the notes on appliance transport.
- ▶ Transport the appliance away without damaging it.
- ▶ Dispose of batteries, lamps, and the appliance according to the above specifications.

13 Additional information

Further information on warranty conditions can be found in the enclosed service brochure or on the Internet at <https://home.liebherr.com>.

Additional information



Reference in the event of an appliance fault:

Model ID / Inventory number:

Quick Start Guide for everyday use

Information about using this Quick Start Guide:

- This Quick Start Guide is not a substitute for the full operating instructions nor is it a substitute for appliance training.
- This Quick Start Guide provides support for everyday use and handling the appliance.
- Read the full operating instructions and the safety instructions contained therein.

This quick start guide is for: SRPvh 14../65../84..



Using the QR code, you can read the full operating instructions.



Intended use

This laboratory refrigerator is suitable for the professional storage of products at temperatures between:

- **Foamed door:** -2 °C (28 °F) and 16 °C (60 °F)*
- **Glass door:** 0 °C (32 °F) and 16 °C (60 °F)*

Foreseeable incorrect use

Do not use the appliance for the following applications:

- Storage and cooling of:
 - Chemically unstable, flammable or corrosive substances
 - Blood, plasma or other body fluids for the purpose of infusion, application or introduction in the human body
- Use in areas with risk of explosion
- Outdoor use or in areas where it is exposed to splash water or damp conditions

When stocking, observe the following points:

- ❑ Position grid shelves according to the height required.
- ❑ Observe maximum load.
- ❑ When the storage temperature has been reached, load the appliance (compliance with cold chain).
- ❑ Items for refrigeration must not come into contact with the evaporator on the rear wall.
- ❑ Keep liquids in closed containers.
- ❑ Leave space when storing items for refrigeration to ensure adequate air circulation.

Status display



Fig. 257

- (1) Actual temperature
- (2) Alarm status
- (3) Defrosting status
- (4) Door lock status

Displaying temperature recording

The temperature recording displays the length of the recording and the minimum and maximum temperatures measured during this period of time.

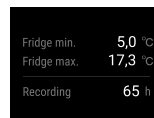

Fig. 258

Resetting temperature recording

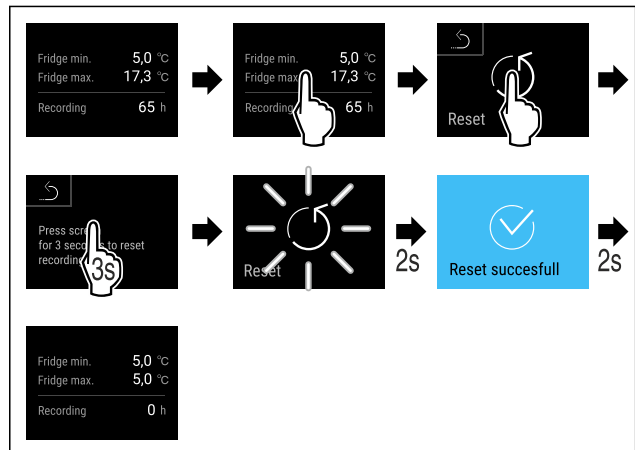

Fig. 259

Quick Start Guide for everyday use

Unlocking door lock with door PIN

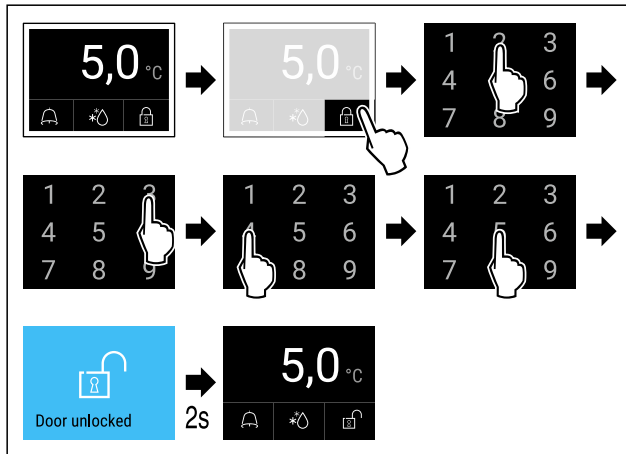

Fig. 260 Example shows PIN 2345

Displaying alarm log

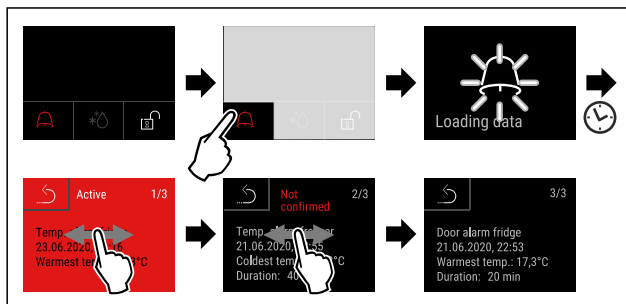

Fig. 263 Example shows an active alarm, an unconfirmed alarm, and a confirmed alarm.

- ▶ Alarm log shows active, confirmed or unconfirmed alarms (maximum 10 alarms).
- ▶ To delete the alarm log: See operating instructions.

Cleaning appliance

- ▶ Empty the appliance.
- ▶ Pull out the power plug.
- ▶ Observe the information in the operating instructions.
- ▶ Dry the appliance and equipment thoroughly after cleaning.
- ▶ Connect the appliance.
- ▶ Switch on the appliance.
- ▶ Load the appliance once the storage temperature is reached.

What should I do if there is a fault?

A message appears in the display if there is a fault. Messages have different meanings:

Symbol color in the display	Meaning	Remedy
YELLOW	Reminder Reminder of general procedures. You can carry out these procedures to eliminate the message.	Consult the operating instructions and perform the troubleshooting steps.
RED	Warning Appears when there are malfunctions. You can eliminate simple malfunctions yourself.	Consult the operating instructions and perform the troubleshooting steps.
If you cannot remedy the fault yourself, contact a competent member of staff or your nearest customer service outlet.		



home.liebherr.com/fridge-manuals

EN Refrigerator
ORIGINAL OPERATOR'S MANUAL

Issue date: 20260313

Part number index: 7083328-00

For service in the United States and Canada: Liebherr Service Center
Toll Free: 1-844-542-6782
Email: service-commercial.us@liebherr.com
PlusOne Solutions, Inc.
3501 Quadrangle Blvd, Suite 120
Orlando, FL 32817

