Wheel loaders for tunnelling operations

LIEBHERR

L 550 – L 576 XPower



Generation
6

Diesel engine
Stage V

Tipping load
12,500 kg – 21,600 kg

Motorway Tunnel

2-Lane

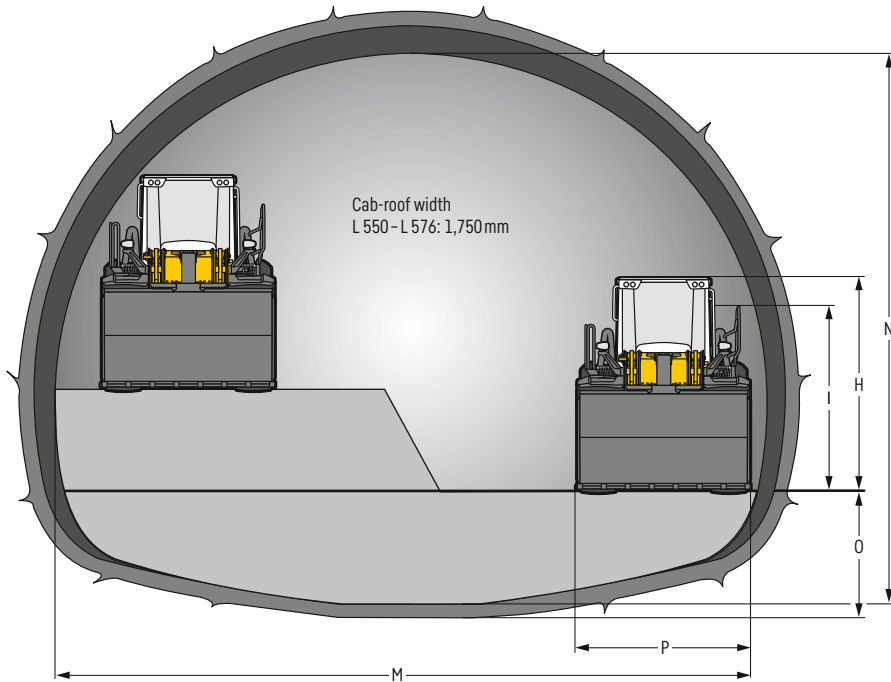
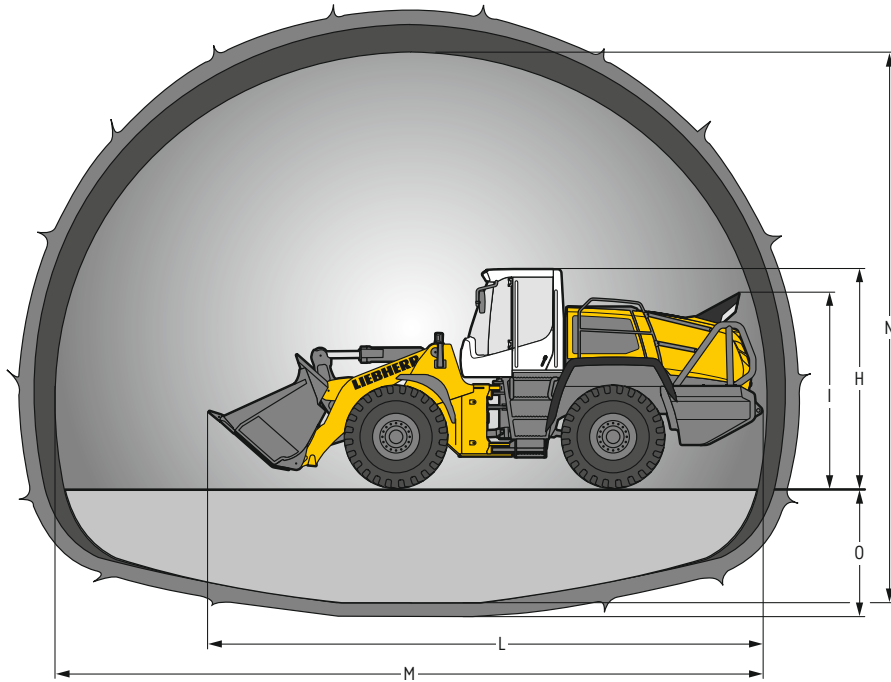

		L 550	L 556	L 566	L 576
H	mm	3,370	3,370	3,590	3,590
I	mm	3,020	3,020	3,200	3,200
L	mm	8,500	8,550	9,280	9,560
M	mm	12,300	12,300	12,300	12,300
N	mm	9,450	9,450	9,450	9,450
O	mm	2,100	2,100	2,100	2,100
P	mm	2,880	2,880	3,000	3,000

The stated values are with HD-bucket.

Technical data

Diesel engine

	L 550	L 556	L 566	L 576	
Diesel engine	D934 A7	D944 A7	D936 A7	D936 A7	
Design	Water-cooled in-series engine with charge-air cooling				
Cylinder inline	4	4	6	6	
Fuel injection process	Electronic Common Rail high-pressure injection				
Output to	160 / 218	180 / 245	200 / 272	215 / 292	
ISO 9249 / ECE-R.24	1.800	1.800	1.800	1.800	
Rated output to					
ISO 14396 / ECE-R.120	163 / 222	183 / 249	203 / 276	218 / 296	
Nominal speed	1.800	1.800	1.800	1.800	
Max. torque to	1.248	1.403	1.914	1.969	
ISO 14396 / ECE-R.120	1.100	1.150	1.000	1.000	
Displacement	litres	7,014	7,964	10,52	10,52
Bore / Stroke	mm	122 / 150	130 / 150	122 / 150	122 / 150
Stage V					
Harmful emissions values	According to regulation (EU) 2016/1628				
Emission control	Liebherr-SCR technology and closed diesel particle filter system				
Air cleaner system	Dry type filter with main and safety element, pre-cleaner, service indicator on the Liebherr display				
Electrical system					
Operating voltage	V	24	24	24	24
Capacity	Ah	2 x 140	2 x 140	2 x 180	2 x 180
Alternator	V/A	28 / 140	28 / 140	28 / 180	28 / 180
Starter	V/kW	24 / 7.8	24 / 7.8	24 / 7.8	24 / 7.8

Driveline

Continuous power split XPower driveline

Design	Continuous, fully-automatic XPower driveline. No traction interruptions across the entire speed range. Hydrostatic power split with two axial piston units. Identical driving performance – forwards and in reverse
Filtration	Filter system for driveline, depend on working hydraulics
Control	Driveline is controlled from travel pedal for tractive force and speed setting with integrated inch function. The Liebherr control lever is used to control forward and reverse travel
Travel speed range	0 - 40* km/h forward and reverse, fully-automatic Speed restriction available upon request. Speeds quoted apply with the tyres indicated as standard on loader model.

* Configuration, tyres and mounting tools can influence the maximum speed.

Brakes

Wear-free service brake	Self-locking of the XPower driveline (acting on all four wheels) and additional pump-accumulator brake system with wet multi-disc brakes (two separate brake circuits)
Parking brake	Electro-hydraulically actuated spring-loaded disc brake system on the transmission

The braking system meets the requirements of the ISO 3450.

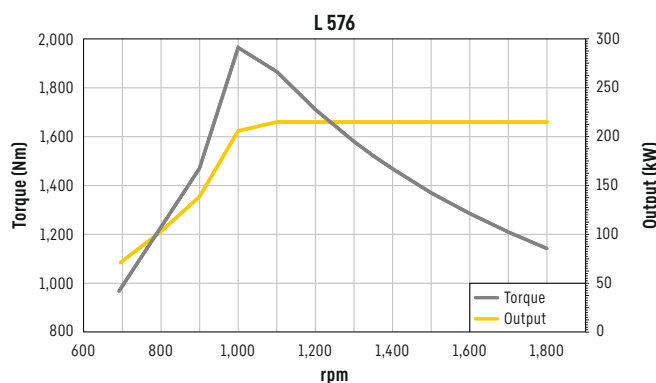
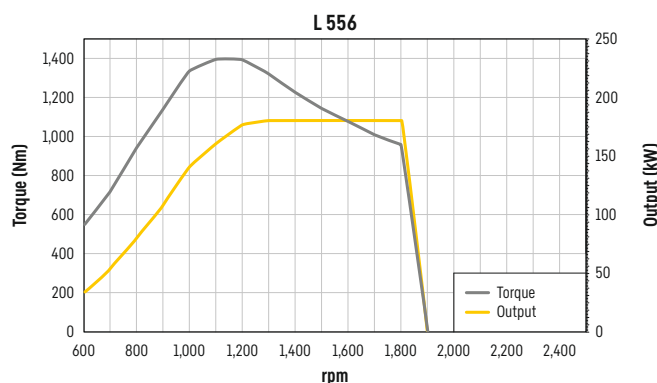
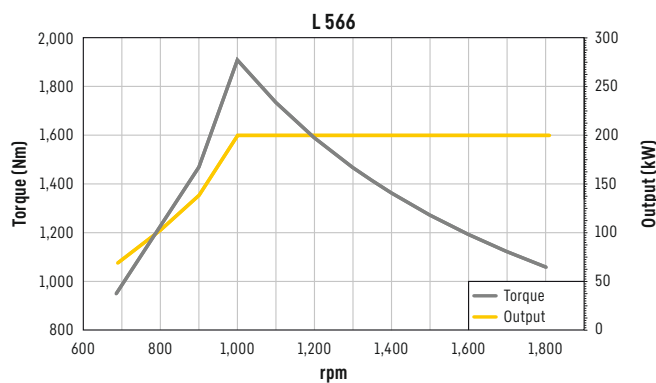
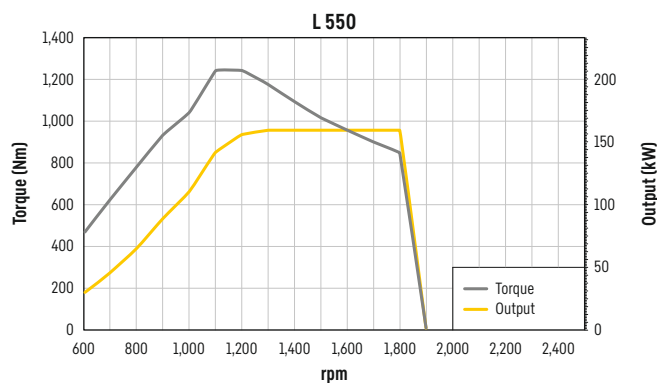

Axles

	L 550	L 556	L 566	L 576	
Four-wheel drive					
Front axle	Fixed				
Rear axle	Centre pivot, with 13° oscillating angle to each side				
Height of obstacles which can be driven over	mm	460	442	492	473
		with all four wheels remaining in contact with the ground			
Differentials	Automatic limited-slip differentials				
Reduction gear	Planetary final drive in wheel hubs				
Track width	2,003 mm with all types of tyres 2,230 mm with all types of tyres (L 566, L 576)				

Steering

Design	“Load-sensing” swash plate type variable flow pump with pressure cut-off and flow control. Central pivot with two double-acting, damped steering cylinders
Angle of articulation	40° to each side 38° to each side (L 566, L576)
Emergency steering	Electro-hydraulic emergency steering system

Attachment hydraulics

	L 550	L 556	L 566	L 576	
Design	“Load-sensing” swash plate type variable flow pump with output and flow control, and pressure cut-off in the control block				
Cooling	Hydraulic oil cooling using thermostatically controlled fan and oil cooler				
Filtration	Return line filter in the hydraulic reservoir				
Control	Liebherr control lever, electro-hydraulically operated				
Lifting function	Lifting, neutral, lowering Automatic lift arm position and lowering by Liebherr control lever Float position controlled by Liebherr control lever				
Tilt function	Tilt back, neutral, dump Automatic bucket return for tilting back and dumping controlled by Liebherr control lever				
Max. flow	l/min.	234	290	290	290
Max. pressure					
Z-bar kinematics	bar	350	350	350	380
Industrial lift arm	bar	380	380	380	

Attachment

	L 550	L 556	L 566	L 576			
Geometry variants							
Optional	Powerful Z-bar kinematics with tilt cylinder and cast steel cross-tube Industrial lift arm with tilt cylinder, hydraulic quick hitch as standard						
Bearings	Sealed						
Cycle time at nominal load	ZK	IND	ZK	IND	ZK	IND	ZK
Lifting	s	5.4	5.4	5.4	5.4	6.1	6.1
Dumping	s	1.0	2.2	1.0	2.2	1.2	2.0
Lowering (empty)	s	2.9	2.9	2.9	2.9	3.2	3.2

Operator's cab

Design	Hydraulically mounted, noise-proof cab ROPS roll over protection per EN ISO 3471 / EN 474-1 FOPS falling objects protection per EN ISO 3449 / EN 474-1, Cat. II Operator's door with sliding side window, sliding side window on right, front windscreen made of compound safety glass, side panels with single-pane safety glass ESG, heated rear window ESG, all windows are tinted. 3 way continuous adjustable steering column
Liebherr operator's seat	6 way adjustable, vibration-damped operator's seat “Comfort” with seat, depth and incline adjustment as standard (air-cushioned with seat heating adjustable to operator's weight), Liebherr control lever mounted into the operator's seat as standard
Cab heating and ventilation	4-zone air conditioning with new improved cooling output as standard, electrically heated rear window, all filters are easy to access and replaceable
Vibration emissions	
Hand / arm vibrations	≤ 2.5 m/s ² , according with ISO 5349-1:2001
Whole-body vibrations	≤ 0.5 m/s ² , complies with technical report ISO/TR 25398:2006
Measuring inaccuracy	According with standard EN 12096:1997

Sound level

	L 550	L 556	L 566	L 576	
Sound pressure level to ISO 6396					
L _{PA} (inside cab)	dB(A)	68	68	68	68
Sound power level to 2000/14/EC					
L _{WA} (surround noise)	dB(A)	104	104	105	105

Capacities

	L 550	L 556	L 566	L 576	
Fuel tank	l	280	280	365	365
DEF tank	l	67.5	67.5	67.5	67.5
Engine oil (inclusive filter change)	l	26	26	42	42
Pump distribution gearbox	l	1.2	1.2	1.2	1.2
XPower gearbox	l	53	53	55	55
Coolant	l	67	67	73	73
Front axle	l	35	42	42	58
Rear axle	l	35	35	42	42
Hydraulic tank	l	105	105	105	105
Hydraulic system, total	l	175	180	190	190
Air conditioning system R134a	g	1,250	1,250	1,250	1,250

Dimensions

Z-bar kinematics

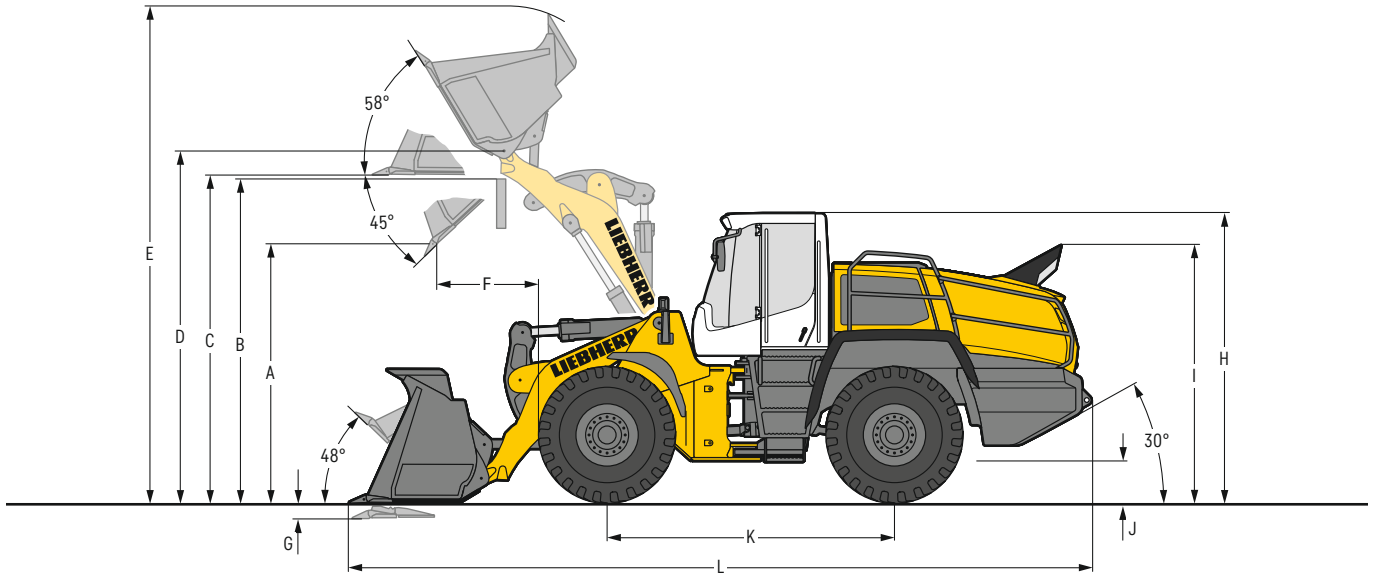

Loading bucket

Geometry	L 550		L 556		L 566		L 576		
	ZK	ZK	ZK	ZK	ZK	ZK	ZK	ZK	
Cutting tools	T+BOCE	ROB	T+BOCE	ROB	T+BOCE	ROB	T+BOCE	ROB	
Lift arm length	mm	2,700	2,700	2,700	2,700	2,920	2,920	3,050	3,050
Bucket capacity according to ISO 7546 **	m ³	3.4	3.1	3.7	3.4	4.2	3.7	4.7	4.0
Specific material density	t/m ³	1.8	1.8	1.8	1.8	1.8	1.8	1.8	1.8
Bucket width	mm	2,880	2,880	2,880	2,880	3,000	3,230	3,000	3,230
A Dumping height at max. lift height and 45° discharge	mm	3,020	3,090	2,970	3,020	3,205	3,130	3,355	3,300
B Dump-over height	mm	3,700	3,700	3,700	3,700	3,900	3,900	4,100	4,100
C Max. height of bucket bottom	mm	3,875	3,875	3,875	3,875	4,050	4,050	4,270	4,270
D Max. height of bucket pivot point	mm	4,150	4,150	4,150	4,150	4,360	4,360	4,580	4,580
E Max. operating height	mm	5,785	5,725	5,855	5,785	6,120	5,900	6,440	6,200
F Reach at max. lift height and 45° discharge	mm	1,025	990	1,075	1,025	1,190	1,270	1,135	1,190
G Digging depth	mm	80	80	80	80	100	100	100	100
H Height above operator's cab	mm	3,370	3,370	3,370	3,370	3,590	3,590	3,590	3,590
I Height above exhaust	mm	3,020	3,020	3,020	3,020	3,200	3,200	3,200	3,200
J Ground clearance	mm	490	490	490	490	535	535	540	540
K Wheelbase	mm	3,500	3,500	3,500	3,500	3,560	3,560	3,630	3,630
L Overall length	mm	8,555	8,475	8,625	8,555	9,280	9,380	9,560	9,620
Turning circle radius over tyres	mm	6,160	6,160	6,160	6,160	6,700	6,700	6,790	6,790
Turning circle radius over outside bucket edge	mm	6,840	6,820	6,860	6,840	7,380	7,400	7,540	7,560
Breakout force (SAE)	kN	165	160	175	170	200	185	200	185
Tipping load, straight *	kg	14,750	14,550	16,250	16,050	18,500	18,000	20,500	20,100
Tipping load, fully articulated *	kg	13,000	12,750	14,250	14,000	16,200	15,700	17,900	17,500
Operating weight *	kg	19,500	19,740	20,550	20,780	25,300	25,600	26,900	27,300
Tyre size		23.5R25 L5				26.5R25 L5			

* The figures shown include the above tyres, all lubricants, a full fuel tank, the ROPS/FOPS cab and the operator. Different tyres and optional equipment will change the operating weight and tipping load. (Tipping load, fully articulated according to ISO 14397-1)

** Actual bucket capacity may be approx. 10% larger than the calculation according to ISO 7546 standard. The degree to which the bucket can be filled depends on the material.

ZK = Z-bar linkage

T+BOCE = Welded-on tooth holder with add-on teeth and bolt-on cutting edge

ROB = Rock bucket with delta cutting edge, welded-on tooth holder with add-on teeth and bolted intermediate sections

Bucket selection

Bulk material densities and bucket filling factors

		t/m ³	%			t/m ³	%			t/m ³	%
Gravel	moist	1.9	105	Earth	dry	1.3	115	Glass waste	broken	1.4	100
	dry	1.6	105		wet excavated	1.6	110		solid	1.0	100
	crushed stone	1.5	100	Topsoil		1.1	110	Compost	dry	0.8	105
Sand	dry	1.5	105	Basalt		1.95	100	wet	1.0	110	
	wet	1.9	110	Granite		1.8	95	Wood chips / Saw dust		0.5	110
Gravel and Sand	dry	1.7	105	Sandstone		1.6	100	Paper	shredded / loose	0.6	110
	wet	2.0	100	Slate		1.75	100	recovered paper / cardboard	1.0	110	
Sand / Clay		1.6	110	Bauxite		1.4	100	Coal	heavy material density	1.2	110
Clay	natural	1.6	110	Limestone		1.6	100	light material density	0.9	110	
	dry	1.4	110	Gypsum	broken	1.8	100	Waste	domestic waste	0.5	100
Clay / Gravel	dry	1.4	110	Coke		0.5	110	bulky waste	1.0	100	
	wet	1.6	100	Slag	broken	1.8	100				

Tyres



Tyre types

	Size and tread code		Change of operating weight kg	Width over tyres mm	Change in vertical dimensions* mm	Use
L 550 XPower / L 556 XPower						
Michelin	23.5R25 XLD D2A	L5	0	2,670	0	Stone, Mining spoil (firm ground conditions)
Bridgestone	23.5R25 VSDT	L5	238	2,670	29	Stone, Mining spoil (firm ground conditions)
Goodyear	23.5R25 RT-5D	L5	208	2,660	29	Stone, Mining spoil (firm ground conditions)
L 566 XPower / L 576 XPower						
Michelin	26.5R25 XLD D2A	L5	0	2,970	0	Stone, Mining spoil (firm ground conditions)
Bridgestone	26.5R25 VSDT	L5	342	2,970	12	Stone, Mining spoil (firm ground conditions)
Goodyear	26.5R25 RT-5D	L5	312	2,990	25	Stone, Mining spoil (firm ground conditions)

* The stated values are theoretical and may deviate in practice.

Before operating the vehicle with tyre foam filling or tyre protection chains, please discuss this with the Liebherr-Werk Bischofshofen GmbH.

Tipping load



What is tipping load?

Load at centre of gravity of working equipment, so that the wheel loader just begins to tip over the front axle. This is the most unfavourable static-load position for the wheel loader. Lifting arms horizontal, wheel loader fully articulated at centre pivot.

Pay load.

The pay load must not exceed 50% of the tipping load when articulated. This is equivalent to a static stability-margin factor of 2.0.

Bucket capacity.

The bucket volume is determined from the pay load.

$$\text{Pay load} = \frac{\text{Tipping load, articulated}}{2}$$

$$\text{Bucket capacity} = \frac{\text{Pay load (t)}}{\text{Specific bulk weight of material (t/m}^3\text{)}}$$

Environmental protection can help you earn money!



Always in fuel saving mode with the Liebherr fuel-saving calculator

100% power with up to 30% less fuel consumption – the Liebherr fuel saving calculator shows how much fuel can be saved compared to similar machines. The online application is available free of charge and provides a quick and simple overview of fuel savings per year in euros. The calculation is based on average fuel consumption, operating hours per year and the current fuel price. The potential savings when operating a Liebherr wheel loader are impressive – see for yourself!

	Ø Litres / hour*
L 526: 2.1 m ³	5.92
L 538: 2.6 m ³	6.53
L 546: 2.8 m ³	7.51
L 550: 3.4 m ³	9.59
L 556: 3.7 m ³	10.63
L 566: 4.2 m ³	12.79
L 576: 4.7 m ³	13.69
L 580: 5.2 m ³	14.31
L 586: 6.0 m ³	17.56

* Wheel loader in operation with a customer-specific machine design. Averages data from MyLiebherr Performance, calculated on 19/11/2024.



Experience just how much fuel you can save!
www.encyplus.liebherr.com

Equipment

 Basic wheel loader	L 550	L 556	L 566	L 576
Additional handrails left	●	●	●	●
Additional handrails right	+	+	+	+
Air pre-cleaner TOP AIR	+	+	+	+
Automatic central lubrication system	+	+	+	+
Automatic delayed engine stop	+	+	+	+
Auxiliary heater (Additional heating with engine preheating)	+	+	+	+
Battery main switch (lockable)	●	●	●	●
Chassis protection front	+	+	+	+
Chassis protection rear	+	+	+	+
Combined inching-braking system	●	●	●	●
Cooling water pre-heating 230 V	+	+	+	+
Crash protection, rear	+	+	+	+
DEF tank	●	●	●	●
Dust protection for alternator	+	+	+	+
Electronic tractive force regulation for difficult ground conditions	●	●	●	●
Fire extinguisher 6 kg	+	+	+	+
Fluff trap for radiator	+	+	+	+
Fuel pre-filter	●	●	●	●
Fuel pre-filter with pre-heating	+	+	+	+
Guard for headlights	+	+	+	+
Headlights halogen (double design on engine hood)	●	●	●	●
Headlights LED (double design on engine hood)	+	+	+	+
Large-mesh radiator	+	+	+	+
Liebherr biodegradable hydraulic oil	+	+	+	+
Liebherr SCR technology incl. diesel particle filter	●	●	●	●
Liebherr weighing system with "Truck Payload Assist" (cannot be certified as a regulated weights and measure device)	+	+	+	+
Lockable doors and engine hood	●	●	●	●
Multi-disc limited slip differentials in both axles	●	●	●	●
Parking brake	●	●	●	●
Pre-heat system for cold starting	●	●	●	●
Ramming guard with guard	+	+	+	+
Rear license panel light	+	+	+	+
Reversible fan drive	+	+	+	+
Ride control	●	●	●	●
Road travel counterweight	●	●	+	-
Speed limiter 20 km/h as a factory preset	+	+	+	+
Speed limiter V _{MAX} adjustable key on the control unit	●	●	●	●
Toolbox with toolkit	●	●	●	●
Towing hitch	●	●	●	●
Travel light (with additional headlights) on front section halogen	+	+	+	+
Travel light (with additional headlights) on front section LED	+	+	+	+
Tunnel package	+	+	+	+
Turbocharger insulation	+	+	+	+
Widening for mudguard	+	+	+	+

 Equipment	L 550	L 556	L 566	L 576
1st additional electro-hydraulic function for continuous sweeper and snow blower operation	+	+	+	+
1st electro-hydraulic, proportional additional function, adjustable delivery flow	+	+	+	+
2nd additional electro-hydraulic function for continuous sweeper and snow blower operation	+	+	+	+
2nd electro-hydraulic, proportional additional function, adjustable delivery flow	+	+	+	+
Adjustable tipping speed	●	●	●	●
Automatic bucket return programmable	●	●	●	●
Automatic lift arm position and lowering programmable	●	●	●	●
Bucket tilt assistant	+	+	+	+
Float position	●	●	●	●
Fork carrier and pallet forks	+	+	+	+
High Lift arms	+	+	+	+
High-dump bucket	+	+	+	+
Hydraulic quick hitch	+	+	+	+
Hydraulic quick hitch Solidlink	+	+	+	+
Industrial lift arm	+	+	+	-
Lift arm Z-bar kinematics	●	●	●	●
Light material bucket	+	+	+	+
Loading buckets incl. a range of cutting tools	+	+	+	+
Log grapple	+	+	+	-
Pipe break protection	+	+	+	+
Pressure relief for hydraulic additional function	+	+	+	+
Stroke limit damping	+	+	+	+
Tilt cylinder protection	+	+	+	+
Visualisation of the equipment position	●	●	●	●
Working hydraulics lockout	●	●	●	●

Equipment



Operator's cab

	L 550	L 556	L 566	L 576
3 way continuously adjustable steering column (height-adjustable, tilting, folding)	●	●	●	●
Access assistance to facilitate cleaning windscreen	●	●	●	●
Adapter plate for additional fastening on the multi-function rail	+	+	+	+
Adaptive working lighting	+	+	+	+
Air conditioning system	●	●	●	●
Amber beacon swiveling / fixed	+	+	+	+
Audible horn control integrated into Liebherr control lever	+	+	+	+
Automatic air conditioning system	+	+	+	+
Bucket return with button integrated into Liebherr control lever	+	+	+	+
Cigarette lighter	●	●	●	●
Clothes hooks (2 pieces)	●	●	●	●
Cool box	+	+	+	+
Electronical theft protection with code	+	+	+	+
Electronical theft protection with key with / without driver identification	+	+	+	+
Exterior mirror, electrical adjustable, with heating	+	+	+	+
Exterior mirror, tiltable and adjustable	●	●	●	●
Fire extinguisher in cab 2 kg	+	+	+	+
First aid kit	+	+	+	+
Floor mat	●	●	●	●
Headlights front, double design, halogen	●	●	●	●
Headlights front, double design, LED	+	+	+	+
Headlights rear, double design, LED	+	+	+	+
Headlights rear, single design, halogen / LED	+	+	+	+
Headlights rear, triple design, LED	+	+	+	+
Integrated tyre pressure monitoring system	+	+	+	+
Interior mirror left and right	+	+	+	+
Interior mirror right	●	●	●	●
Joystick steering	+	+	+	+
Liebherr Connect				
MyLiebherr Maintenance	+	+	+	+
MyLiebherr Performance	+	+	+	+
MyLiebherr Portal*	●	●	●	●
Liebherr control lever moving with operator's seat (incl. kick down, travel direction)	●	●	●	●
Liebherr control lever with mini-joystick for 1st and 2nd electro-hydraulic, proportional additional function moving with operator's seat	+	+	+	+
Liebherr key with remote control incl. Coming Home / Leaving Home function	+	+	+	+
Liebherr multi-lever control system moving with operator's seat (incl. kick down, travel direction)	+	+	+	+
Operating hour meter (integrated in display unit)	●	●	●	●
Operating hour meter (mechanic)	+	+	+	+
Operator seat "Comfort" - with longitudinal absorption and seat heating	●	●	●	●
Operator seat "Premium" - with longitudinal and transverse absorption, seat climate control	+	+	+	+



Operator's cab

	L 550	L 556	L 566	L 576
Operator's cab without steering wheel / steering column (not available as street legal) - joystick steering only	+	+	+	+
Particle filter F7	●	●	●	●
Power socket 12 V	●	●	●	●
Power socket USB	●	●	●	●
Premiumdisplay (Touchscreen), with height adjustment and tilting function	●	●	●	●
Preparation for protective ventilation and dust filtrating device	+	+	+	+
Preparation for radio installation	+	+	+	+
Radio Liebherr "Comfort" (DAB+ / USB / AUX / BLUETOOTH / handsfree set)	+	+	+	+
Radio Liebherr "Standard" (USB / AUX)	+	+	+	+
Rear window heated electrically	●	●	●	●
Sliding window left/right	●	●	●	●
Slipcover for operator seat	+	+	+	+
Soundproof ROPS / FOPS cab	●	●	●	●
Steering stabilisation	●	●	●	●
Storage box left	●	●	●	●
Sunblind front	●	●	●	●
Sunblind rear	+	+	+	+
Wide angle mirror	+	+	+	+
Windscreen guard	+	+	+	+
Windscreen wiper single-sweep function with button	+	+	+	+
Wipe and wash system	●	●	●	●



Safety

	L 550	L 556	L 566	L 576
Active personnel detection at the rear	+	+	+	+
Back-up alarm acoustic / visual	+	+	+	+
Country-specific versions	+	+	+	+
Emergency steering system	●	●	●	●
Rear space monitoring with camera (with Liebherr camera via Liebherr display)	●	●	●	●
Reversing obstruction detector	+	+	+	+
Roof camera for front area monitoring (with Liebherr camera via Liebherr display)	+	+	+	+
Skyview 360°	+	+	+	+

- = Standard
- + = Option
- = not available
- * = activation required free of charge

Further information can be found in the brochure "Assistance systems for wheel loaders" or you can find here:



Here you can download our wheel loader brochures:



