

L 526 – L 546

LIEBHERR

Wheel loaders

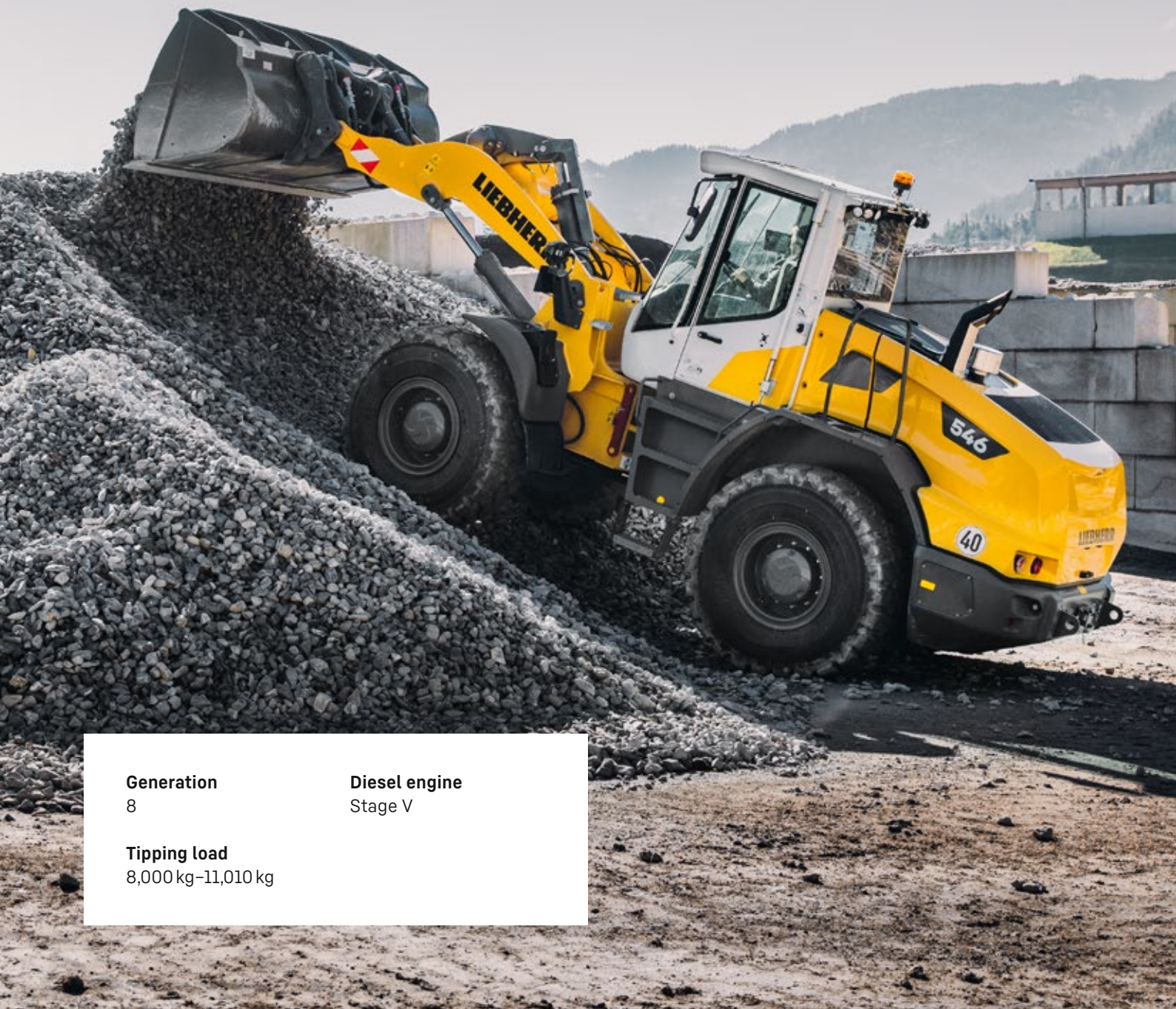

Generation
8

Diesel engine
Stage V

Tipping load
8,000 kg–11,010 kg

Performance

Versatile all-rounders –
wheel loaders for every application

Economy

Efficient powerhouse –
low costs with high handling capacity

Reliability

Reliable performers –
proven quality for durable machines

Comfort

Intelligent engineering –
when technology delivers comfort and safety

Maintainability

Secure both time and cost savings –
thanks to quick and simple maintenance





L 526

Tipping load, articulated
8,730 kg
Bucket capacity
2.2 m³
Operating weight
13,170 kg
Engine output
116 kW / 158 HP

L 538

Tipping load, articulated
9,650 kg
Bucket capacity
2.6 m³
Operating weight
14,520 kg
Engine output
129 kW / 175 HP

L 546

Tipping load, articulated
11,010 kg
Bucket capacity
3.0 m³
Operating weight
15,410 kg
Engine output
138 kW / 188 HP

Performance



Versatile all-rounders – wheel loaders for every application

The optimised z-bar kinematics on Liebherr's mid-sized wheel loaders is powerful and performance-oriented and can be used in countless ways. In combination with the proven Liebherr travel drive and the wide selection of now-larger standard buckets, the variety of possible applications is taken to a new level.

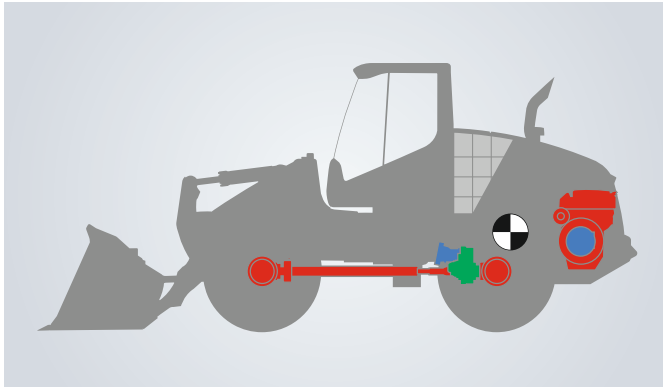

Powerful machine design

- The drive components installed in the rear of the wheel loader serve as a natural counterweight and are part of the sophisticated counterweight design
- Ideal weight distribution leads to higher tipping loads and thus greater productivity
- The balanced weight distribution increases efficiency and saves fuel
- Strong designs and robust steel ensure reliable and powerful performance



Hydrostatic travel drive

- The Liebherr travel drive enables continuous acceleration in all speed ranges, without noticeable gear changes or loss of tractive force
- Increased torque enable even better acceleration and faster operation
- Reduced engine speeds provide further fuel savings, lowering operating costs



Powerful, optimised z-bar kinematics

- New, optimised z-bar kinematics enables roughly 20% more breakout force than the previous generation
- Faster tilting movements and cycle times means more efficient operation
- Longer lift arms and the resulting higher reach and dump over heights makes daily operation even easier
- State-of-the-art electro-hydraulic components enable functions such as optimum parallel fork guidance prongs at the touch of a button



A plethora of options, configurable to your needs

- The diverse selection of factory equipment means that the right tool is always available
- Larger standard buckets ensure greater handling performance in the same amount of time
- The robust bucket design enables fast, efficient bucket filling
- Modular bucket construction allows for individual configuration, suitable for any application

Economy



Efficient powerhouse – low costs with high handling capacity

Power, speed, and durability, combined with innovative technology, results in an optimum machine design. The efficient hydrostatic travel drive and robust components reduce operating costs in a sustainable way, putting more money in your pocket.



Maximum productivity with minimum fuel consumption

- Liebherr power efficiency (LPE) optimises the interaction between the diesel engine, transmission, and working hydraulics for maximum efficiency
- Liebherr travel drive with LPE provides enormous fuel savings
- At the highest efficiency, operating costs are reduced, and profitability is increased



Intelligent solutions for limiting wear

- The Liebherr travel drive brakes automatically, the service brakes only have a supporting effect, meaning they remain almost wear-free
- Continuous tractive force control combined with limited slip differentials prevents wheel spin, thereby increasing productivity and significantly reducing tyre wear



Liebherr Connect

- Intelligent machine networking with digital services and machine and process data
- For use in fleet and asset management systems and monitoring the condition of machines and components
- Efficient data exchange with customisation of the machine

MyLiebherr Portal

- Extensive benefits, digital services and software solutions for efficient machine operation
- Machine management, spare part orders and licence acquisition following one-time registration

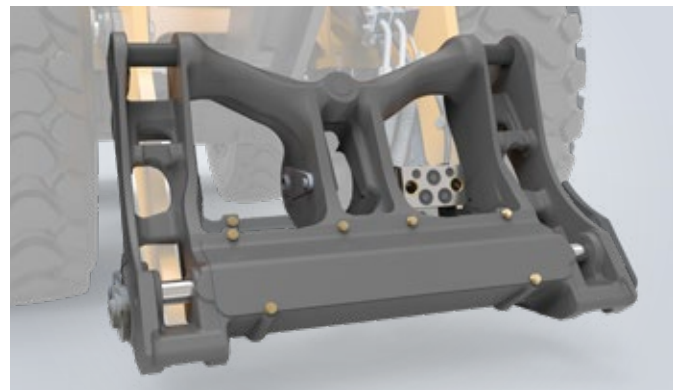

Solidlink

- Optional hydraulic quick coupler with integrated, automatic 3rd & 4th hydraulic circuit
- Hydraulic working tools can be changed in seconds directly from the cab
- The changeover is fully automatic, safe and leak-free
- Time savings thanks to greater convenience lead to increased productivity, saving time and money

Reliability



Reliable performers – proven quality for durable machines

The development of Liebherr's next generation of mid-sized wheel loaders centered around feedback from those most important to us, our customers. This, combined with decades of industry experience, has resulted in Liebherr's most powerful and high-performance mid-sized wheel loaders ever. The machines' premium quality and reliability stems from the integration of sophisticated technology and benchmark-setting componentry.



High-performance, durable components

- Decades of experience in the development, design, and manufacture of components ensures robustness and durability
- Ideal coordination of the individual components for maximum performance
- High-quality Liebherr standards ensure reliability even under the toughest operating conditions



Uninterrupted operation

- The diesel oxidation catalyst (DOC), diesel particle filter (DPF), and selective catalytic reduction (SCR) are installed for exhaust gas treatment, effectively reducing emissions
- The diesel particle filter can be cleaned during operation via active regeneration, thus enabling uninterrupted work
- Longer intervals between regenerations increases productivity, saves fuel, and reduces operating costs



Reliable Liebherr drive design

- The proven Liebherr hydrostatic travel drive is extremely robust and powerful, ensuring a long service life
- The enlarged travel pumps and motors effectively increase the tractive force, providing greater power output



Optimal cooling capacity

- The radiator is installed behind the cab – the cleanest spot on the wheel loader
- Cooling air is drawn into the system behind the operator's cab and flows through the entire engine compartment
- Demand-controlled cooling via thermostatic control for reliable operation
- High machine availability due to less radiator contamination

Comfort



Intelligent engineering – when technology delivers comfort and safety

Get in the comfort zone – get in a Liebherr wheel loader cab. The modern cab design is optimally adapted to the day-to-day needs of machine operators. The spacious and ergonomically-designed operator's cab provides the perfect conditions for comfortable and productive working and can be individually adjusted to the respective operator.



Modern cab design for greater productivity

- The modern, ergonomic cab design enables concentrated and fatigue-free work
- The displays, controls, and the operator's seat are ideally-coordinated and form an ergonomic unit
- Individual adjustment options for the operator's seat and the steering wheel mean the operator has a relaxed working atmosphere with plenty of legroom
- Numerous storage compartments and well-thought-out solutions provide plenty of space throughout the cab



Keep an eye on everything – for hazard-free work

- The extensive use of glass in the cab provides excellent all-round visibility
- The engine bonnet was designed to optimize visibility. This, together with the integrated back-up camera, ensures excellent lines of sight and provides for greater safety



Innovative joystick steering

- Optional joystick steering is integrated into the operator's seat for ergonomic and comfortable operation
- Intuitive operating behaviour resembles that of a steering wheel
- The angle of the joystick corresponds to the desired machine articulation angle
- Speed-dependent force feedback ensures precise and safe steering behaviour
- The machine can also be ordered without a steering wheel, thanks to joystick steering only, making constant switching between the wheel and the controls a thing of the past



Assistance systems: increase safety – conveniently

- Active personnel detection monitors the rear area of the wheel loader and warns of hazards with a visual and acoustic signal
- Front space monitoring ensures optimised visibility when using large attachments
- Skyview 360° simplifies monitoring of the machine surroundings environment on a separate display in the cab
- The weighing system with "Truck Payload Assist" ensures faster and more accurate loading cycles
- Further assistance systems are available upon customer request

Maintainability



Secure both time and cost savings – thanks to quick and simple maintenance

Intelligent component installation, quick and easy access to the engine compartment, and attention to every last detail are crucial for effective maintenance work. All installed parts which require servicing can be reached safely and comfortably, saving time and money.



Safe and easy service access

- All maintenance points are accessible safely, easily, quickly and cleanly
- Non-slip treads and sturdy handrails ensure maximum safety when cleaning
- The entire engine compartment can be accessed by opening just one bonnet
- All maintenance points are accessible from the ground
- Safe access to the articulation area of the wheel loader
- Simplified accessibility of the refuelling pump enables quick and easy fuel filling



Low maintenance due to intelligent design

- Simple and safe maintenance ensures less downtime
- Less radiator contamination due to its well thought-out position directly behind the operator's cab
- Active regeneration of exhaust gas saves time and money
- Access to the SCR tank is in an optimal position directly next to the diesel tank nozzle



MyLiebherr Maintenance

- Current information on the condition of the machine and attachments
- Reduced unplanned machine standstills thanks to practical recommendations and proactive maintenance planning
- Time saved when identifying, evaluating and solving problems

My Liebherr Performance

- Information on the performance data from the machines and attachments
- Efficient solutions for saving fuel and reducing idle times



Liebherr-Service

- Effective and timely support from a well-staffed service network
- Fast and safe service provision by qualified service specialists

Focus on performance and power

Lift arms

Solid and versatile – the intelligently-designed lift arms with the newly-optimized z-bar kinematics stand out for their faster tilting movements and cycle times. The increased range in roll out and roll back, increased digging depth, and push-button parallel guidance for fork operation increase productivity tremendously. Further-refined lift arms and tilt cylinders as well as a stronger front frame design makes the wheel loader a veritable powerhouse with unlimited application possibilities.

Performance bucket

Configurable and durable – the enlarged standard buckets provide more bucket capacity as well as a greater tire clearance, resulting in significantly more handling capacity per loading cycle. The modular bucket design allows individual configuration for each application and ensures maximum handling performance. The optimised design of the quick coupler improves visibility and provides an optimal view of the load, thereby increasing safety. The optional bucket tilt assist, with automatic metered dump and bucket shake features, makes easy even the toughest of applications.





Machine networking

Liebherr Connect networks the machine into the digital world. Intelligent machine networking provides access to digital services as well as machine and process data. The system ensures an efficient data exchange and offers various options to further develop the machine and customise it to individual customer requirements.

Design

All-round dynamic – the new wheel loaders stand out thanks to their well thought-out design, which begins with the modern exterior styling, and finishes with the dynamic travel drive at the heart of the machine. Optimised and further developed all around, Liebherr wheel loaders offer state-of-the-art engineering down to the smallest detail.

Technology

Powerful and robust – the enlarged working hydraulic pumps and automatic pressure relief for auxiliary hydraulic circuits ensure that work can be undertaken in a safe and comfortable manner. The same tasks can thus be completed in less time. The optimised driving dynamics ensures that any material can be moved from point A to point B – quickly. The longer wheelbase delivers increased stability and ride comfort.

Technical data

Diesel engine

	L 526	L 538	L 546
Diesel engine	4045CB551	4045CB551	6068HB551
Design	Water-cooled turbocharged in-series engine with cooled exhaust gas recirculation		
Cylinder inline	4	4	6
Fuel injection process	Electronic Common Rail high-pressure injection		
Output to	114/155	126/171	148/201
ISO 9249 - SAE J1349	1,800	1,800	2,000
Rated output to			
ISO 14396/ECE-R.120	116/158	129/175	138/188
Nominal speed	2,200	2,200	2,200
Max. torque to	667	667	809
ISO 14396	1,600	1,600	1,600
Displacement	4.5	4.5	6.8
Bore/Stroke	106/127	106/127	106/127
Stage V			
Harmful emissions values	According to regulation (EU) 2016/1628		
Emission control	SCR technology and closed diesel particle filter system		
Air cleaner system	Dry type filter with main and safety element, pre-cleaner, service indicator on the Liebherr display		
Electrical system			
Operating voltage	V 24	24	24
Battery	Ah 2x135	2x135	2x135
Alternator	V/A 24/100	24/100	24/100
Starter	V/kW 24/7.8	24/7.8	24/7.8

Driveline

Continuous hydrostatic driveline	
Design	Swash plate type variable flow pump and two variable axial piston motors in closed loop circuit and axle transfer case. Direction of travel is reversed by changing the flow-direction of the variable-displacement pump
Filtration	Suction return line filter for closed circuit
Control	By travel and inching pedal. The inching pedal makes it possible to control the tractive and thrust forces steplessly at full engine speed. The Liebherr control lever is used to control forward and reverse travel
Travel speed range	Speed range 1 _____ 0- 8 km/h Speed range A1-2 _____ 0-16 km/h Speed range A1-3 _____ 0-40 km/h* forward and reverse Speeds quoted apply with the tyres indicated as standard on loader model.

* Configuration, tyres and mounting tools can influence the maximum speed.

Brakes

Wear-free service brake	Self-locking of the hydrostatic driveline (acting on all four wheels) and additional pump-accumulator brake system with wet multi-disc brakes located in the differential housing (two separate brake circuits)
Parking brake	Electro-hydraulically actuated spring-loaded disc brake system on the front axle

The braking system meets the requirements of the ISO 3450.

L 526

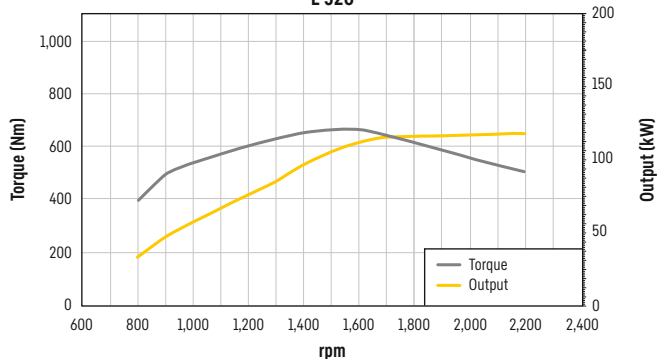

L 538

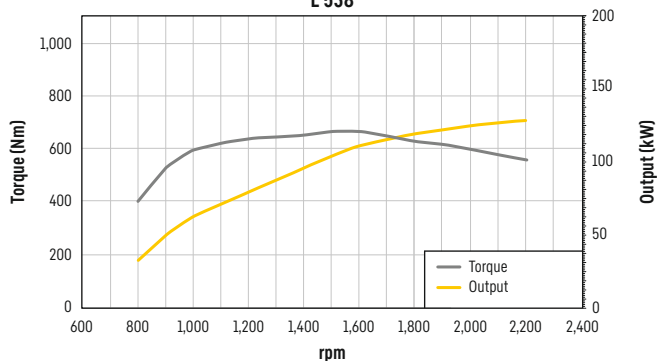

L 546

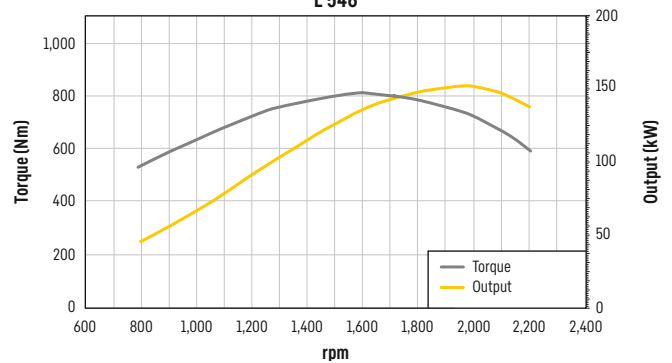

Axles

	L 526	L 538	L 546
Four-wheel drive			
Front axle	Fixed		
Rear axle	Centre pivot, with 10° oscillating angle to each side		
Height of obstacles which can be driven over	mm	470	470
	with all four wheels remaining in contact with the ground		
Differentials	Automatic limited-slip differentials with 45 % locking action in both axles		
Reduction gear	Planetary final drive in wheel hubs		
Track width	1,900 mm with all types of tyres		

Steering

Design	"Load-sensing" swash plate type variable flow pump with pressure cut-off and flow control. Central pivot with two double-acting steering cylinders		
Angle of articulation	40° to each side		
Emergency steering	Electro-hydraulic emergency steering system		

Attachment hydraulics

	L 526	L 538	L 546
Design	"Load-sensing" variable axial piston pump with output and flow control, and pressure cut-off in the control block		
Cooling	Hydraulic oil cooling using thermostatically controlled fan and oil cooler		
Filtration	Return line filter in the hydraulic reservoir		
Control	Liebherr control lever, electro-hydraulically operated		
Lifting function	Lifting, neutral, lowering Auto lifting and lowering using Liebherr control lever, float position using Liebherr control lever		
Tilt function	Tilt back, neutral, dump Automatic bucket return-to-dig for tilting in and out using Liebherr control lever		
Max. flow	l/min.	170	200
Max. pressure	bar	350	350

Attachment

	L 526	L 538	L 546
Geometry	Powerful, optimised z-bar kinematics with one tilt cylinder, optional hydraulic quick coupler		
Bearings	Sealed		
Cycle time at nominal load	ZK	ZK	ZK
Lifting	s	5.0	5.5
Dumping	s	1.2	1.9
Lowering (empty)	s	3.9	4.9

Operator's cab

Design	Elastic mounted, noise-proof cab ROPS roll over protection per EN ISO 3471 / EN 474-1 FOPS falling objects protection per EN ISO 3449 / EN 474-1, Cat. II Driver's cab door with 105° opening angle and opening window with 5° gap opener or 170° opening, right side sliding side window, front windscreen made of laminated safety glass, green tinted as standard, side panels with single-pane safety glass ESG, green tinted, heated rear window ESG. Continuously adjustable steering column 6 way adjustable, vibration-damped operator's seat "Comfort" with seat, depth and incline adjustment as standard (air-cushioned with seat heating adjustable to operator's weight), Liebherr control lever mounted into the operator's seat as standard		
Liebherr operator's seat			
Cab heating and ventilation	2-level air control, cooling water heating, defroster and air conditioning via manual nozzle position or electronic valve control for head and front area, as well as electronic fresh / recirculated air control, electrically heated rear window, filter system with pre-filter, fresh air filter and recirculated air filter, easily replaced, air condition / automatic air conditioning system with new improved cooling output optional		
Vibration emissions			
Hand / arm vibrations	≤ 2.5 m/s ² , according with ISO 5349-1:2001		
Whole-body vibrations	≤ 0.5 m/s ² , complies with technical report ISO/TR 25398:2006		
Measuring inaccuracy	According with standard EN 12096:1997		

Sound level

	L 526	L 538	L 546
Sound pressure level to ISO 6396			
L _{PA} (inside cab)	dB(A)	69	69
Sound power level to 2000/14/EG			
L _{WA} (surround noise)	dB(A)	102	102
		104	104

Capacities

	L 526	L 538	L 546
Fuel tank (plastic design)	l	205	205
Fuel tank (steel version, optional)	l	205	205
DEF tank	l	20	20
Engine oil (inclusive filter change)	l	21	23.5
Transmission	l	2.5	2.5
Coolant	l	26.5	26.5
Front axle / wheel hubs	l	16 / 2.5	19 / 3.5
Rear axle / wheel hubs	l	16 / 2.5	19 / 3.5
Hydraulic tank	l	95	95
Hydraulic system, total	l	170	180

Dimensions

Loading bucket

L 526 – L 546

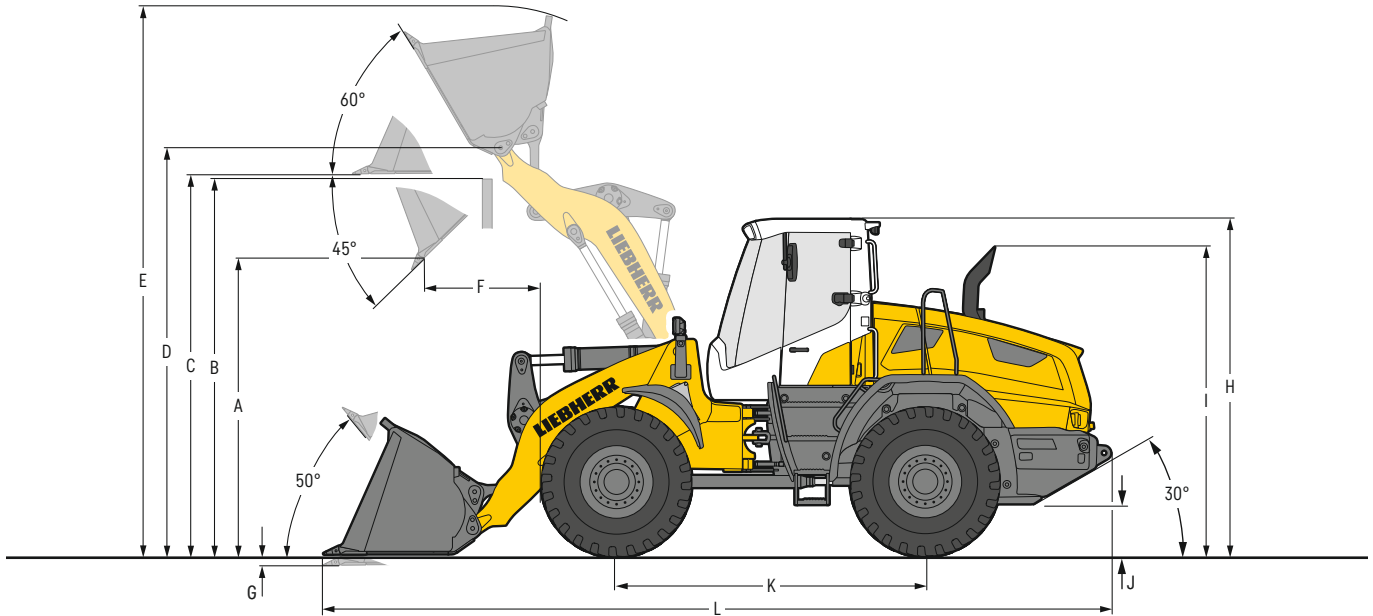

Loading bucket

	L 526			L 538			L 546			
	ZK	ZK-QH	ZK	ZK	ZK-QH	ZK	ZK	ZK-QH	ZK	
Geometry										
Cutting tools	T	T	T	T	T	T	T	T	T	
Lift arm length	mm	2,550	2,550	2,550	2,650	2,650	2,650	2,650	2,650	
Bucket capacity according to ISO 7546**	m ³	2.2	2.0	2.4	2.6	2.4	2.8	3.0	3.2	
Specific material density	t/m ³	1.8	1.8	1.6	1.8	1.8	1.6	1.8	1.6	
Bucket width	mm	2,520	2,520	2,520	2,720	2,520	2,720	2,720	2,720	
A Dumping height at max. lift height and 45° discharge	mm	2,900	2,815	2,855	2,960	2,830	2,935	2,900	2,860	
B Dump-over height	mm	3,450	3,450	3,450	3,540	3,540	3,540	3,540	3,540	
C Max. height of bucket bottom	mm	3,615	3,615	3,615	3,720	3,720	3,720	3,720	3,720	
D Max. height of bucket pivot point	mm	3,875	3,875	3,875	3,980	3,980	3,980	3,980	3,980	
E Max. operating height	mm	5,100	5,150	5,170	5,270	5,390	5,310	5,360	5,430	
F Reach at max. lift height and 45° discharge	mm	945	1,020	990	1,085	1,210	1,110	1,150	1,235	
G Digging depth	mm	100	100	100	100	100	100	100	100	
H Height above operator's cab ¹⁾	mm	3,250	3,250	3,250	3,250	3,250	3,250	3,250	3,250	
I Height above exhaust	mm	2,950	2,950	2,950	2,950	2,950	2,950	2,950	2,950	
J Ground clearance	mm	440	440	440	430	430	430	430	430	
K Wheelbase	mm	2,975	2,975	2,975	3,025	3,025	3,025	3,025	3,025	
L Overall length	mm	7,480	7,600	7,550	7,630	7,810	7,670	7,720	7,850	
Turning circle radius over tyres	mm	5,365	5,365	5,365	5,420	5,420	5,420	5,420	5,420	
Turning circle radius over outside bucket edge	mm	5,950	5,990	5,970	6,140	6,100	6,150	6,165	6,200	
Breakout force (SAE)	kN	110	100	105	125	115	120	140	135	
Tipping load, straight*	kg	10,100	9,350	10,050	11,200	10,400	11,150	12,500	11,600	
Tipping load, fully articulated*	kg	8,730	8,000	8,650	9,650	8,880	9,610	11,010	10,900	
Operating weight*	kg	13,170	13,570	13,210	14,520	14,900	14,550	15,410	15,440	
Tyre size		20.5R25 L3			20.5R25 L3			20.5R25 L3		

* The figures shown include the above tyres, all lubricants, a full fuel tank, the ROPS/FOPS cab and the operator. Different tyres and optional equipment will change the operating weight and tipping load. (Tipping load, fully articulated according to ISO 14397-1)

** Actual bucket capacity may be approx. 10% larger than the calculation according to ISO 7546 standard. The degree to which the bucket can be filled depends on the material – see page 12.

¹⁾ With the optional "comfort safety door (can be opened 180°)", the "H" value increases by 130 mm when door is open.

ZK = Z-bar linkage

ZK-QH = Z-bar linkage incl. quick hitch

T = Welded-on tooth holder with add-on teeth

Dimensions

High lift arm/standard bucket

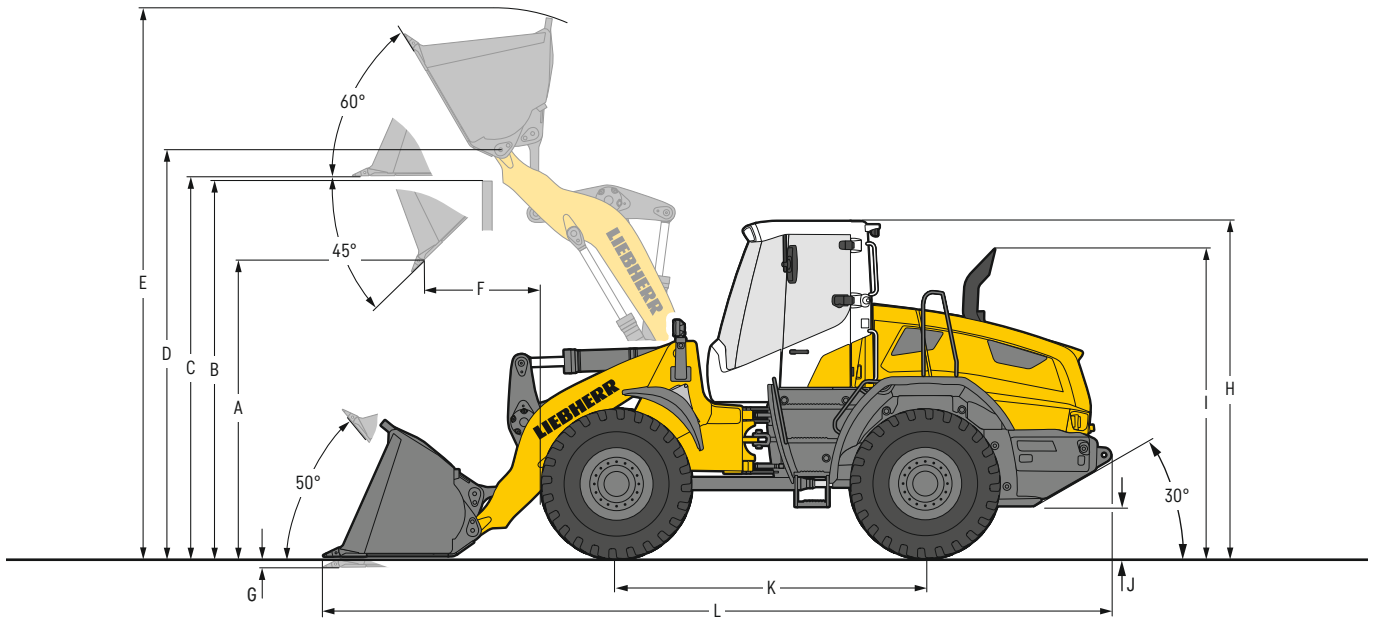

Loading bucket

	L 526		L 538		L 546		
	ZK	ZK-QH	ZK	ZK-QH	ZK	ZK-QH	
Geometry							
Cutting tools	T	T	T	T	T	T	
Lift arm length	mm	3,000	3,000	3,000	3,000	3,000	
Bucket capacity according to ISO 7546**	m ³	2.0	2.0	2.4	2.2	2.8	
Specific material density	t/m ³	1.6	1.5	1.6	1.6	1.6	
Bucket width	mm	2,520	2,520	2,520	2,520	2,720	
A Dumping height at max. lift height and 45° discharge	mm	3,530	3,400	3,500	3,415	3,470	
B Dump-over height	mm	4,015	4,015	4,070	4,070	4,070	
C Max. height of bucket bottom	mm	4,200	4,200	4,260	4,260	4,260	
D Max. height of bucket pivot point	mm	4,460	4,460	4,520	4,520	4,520	
E Max. operating height	mm	5,620	5,740	5,820	5,870	5,850	
F Reach at max. lift height and 45° discharge	mm	850	975	935	1,010	960	
G Digging depth	mm	120	120	120	120	120	
H Height above operator's cab ¹⁾	mm	3,250	3,250	3,250	3,250	3,250	
I Height above exhaust	mm	2,950	2,950	2,950	2,950	2,950	
J Ground clearance	mm	440	440	430	430	430	
K Wheelbase	mm	2,975	2,975	3,025	3,025	3,025	
L Overall length	mm	7,980	8,160	8,080	8,200	8,120	
Turning circle radius over tyres	mm	5,365	5,365	5,420	5,420	5,420	
Turning circle radius over outside bucket edge	mm	6,200	6,260	6,260	6,300	6,360	
Breakout force (SAE)	kN	115	105	130	120	145	
Tipping load, straight*	kg	7,900	7,200	9,300	8,620	10,410	
Tipping load, fully articulated*	kg	6,760	6,100	7,990	7,350	9,200	
Operating weight*	kg	13,430	13,870	14,670	15,070	15,580	
Tyre size		20.5R25 L3		20.5R25 L3		20.5R25 L3	

* The figures shown include the above tyres, all lubricants, a full fuel tank, the ROPS/FOPS cab and the operator. Different tyres and optional equipment will change the operating weight and tipping load. (Tipping load, fully articulated according to ISO 14397-1)

** Actual bucket capacity may be approx. 10% larger than the calculation according to ISO 7546 standard. The degree to which the bucket can be filled depends on the material – see page 12.

¹⁾ With the optional "comfort safety door (can be opened 180°)", the "H" value increases by 130 mm when door is open.

ZK = Z-bar linkage

ZK-QH = Z-bar linkage incl. quick hitch

T = Welded-on tooth holder with add-on teeth

Attachment

Light material bucket

L 526 – L 546

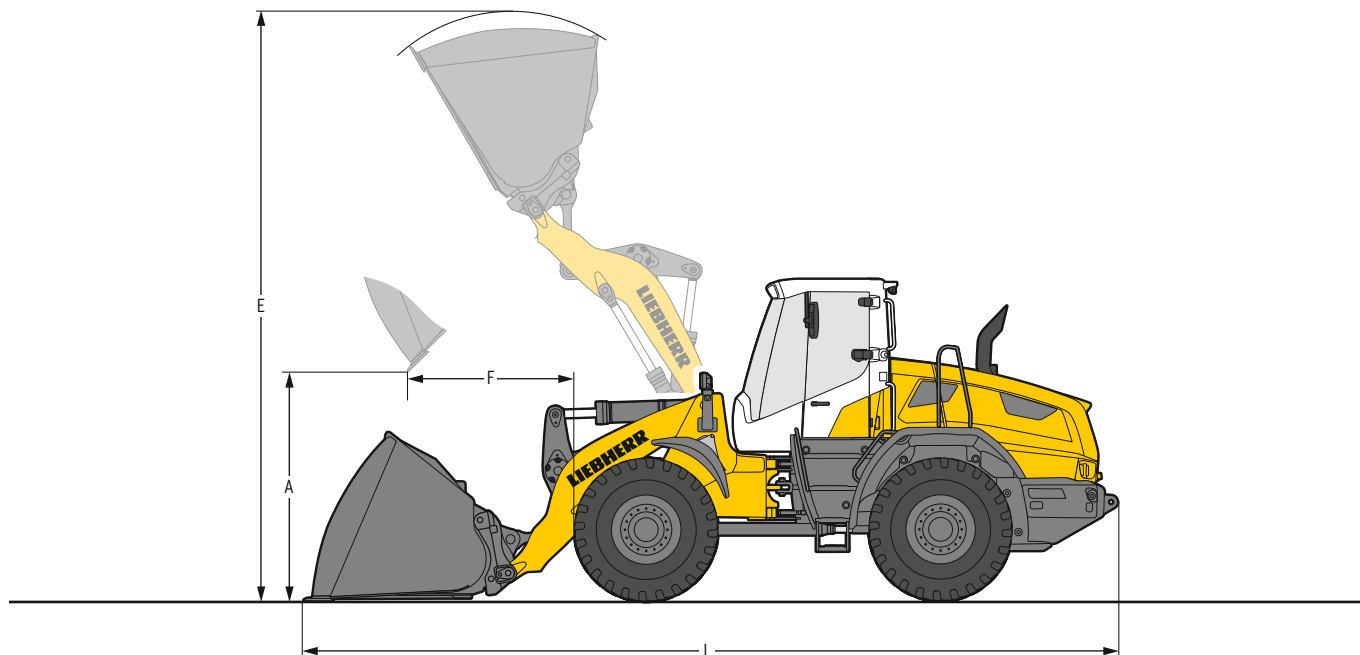

Heavy material density

	L 526		L 538		L 546	
	ZK	ZK-QH	ZK	ZK-QH	ZK	ZK-QH
Geometry						
Cutting tools	BOCE	BOCE	BOCE	BOCE	BOCE	BOCE
Bucket capacity	m ³ 3.5	3.5	4.0	4.0	4.5	4.5
Specific material density	t/m ³ 1,05	1,0	1,05	1,0	1,05	1,0
Bucket width	mm 2,700	2,700	2,700	2,700	2,700	2,700
A Dumping height at max. lift height	mm 2,590	2,490	2,595	2,520	2,510	2,440
E Max. operating height	mm 5,300	5,400	5,510	5,610	5,620	5,730
F Reach at maximum lift height	mm 1,230	1,320	1,420	1,490	1,510	1,570
L Overall length	mm 7,750	7,890	7,970	8,080	8,090	8,190
Tipping load, straight*	kg 9,600	8,900	10,600	10,000	11,820	11,200
Tipping load, fully articulated*	kg 8,230	7,590	9,090	8,520	10,140	9,560
Operating weight*	kg 13,450	13,890	14,790	15,220	15,700	16,120
Tyre size	20.5R25 L3		20.5R25 L3		20.5R25 L3	



Light material density

	L 526	L 538	L 546
	ZK-QH	ZK-QH	ZK-QH
Geometry			
Cutting tools	BOCE	BOCE	BOCE
Bucket capacity	m ³ 5.5	6.5	7.5
Specific material density	t/m ³ 0.5	0.5	0.5
Bucket width	mm 2,700	2,700	3,000
A Dumping height at max. lift height	mm 2,210	2,190	2,160
E Max. operating height	mm 5,800	6,080	6,110
F Reach at maximum lift height	mm 1,610	1,830	1,855
L Overall length	mm 8,300	8,550	8,590
Tipping load, straight*	kg 8,500	9,500	10,600
Tipping load, fully articulated*	kg 7,170	8,020	8,960
Operating weight*	kg 14,200	15,620	16,620
Tyre size	20.5R25 L3		20.5R25 L3

* The figures shown include the above tyres, all lubricants, a full fuel tank, the ROPS/FOPS cab and the operator. Different tyres and optional equipment will change the operating weight and tipping load. (Tipping load, fully articulated according to ISO 14397-1)

For wheel loaders with large light material buckets and high-dump buckets or log grapples, we supply visual aids such as mirrors or cameras for front area monitoring that meet the requirements of the ISO 5006:2017 field of vision test.

ZK = Z-bar linkage

ZK-QH = Z-bar linkage incl. quick hitch

BOCE = Bolt-on cutting edge

Attachment

High lift arm/light material bucket

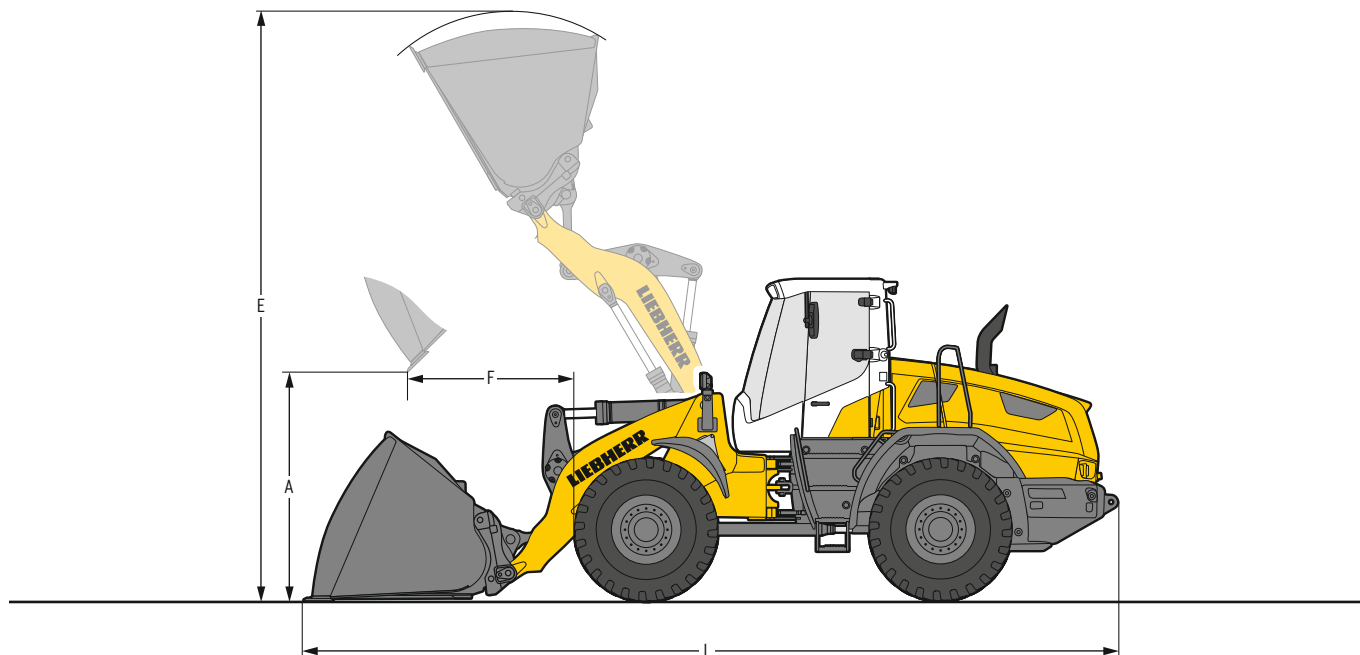

Heavy material density

	L 526		L 538		L 546	
	ZK	ZK-QH	ZK	ZK-QH	ZK	ZK-QH
Geometry						
Cutting tools	BOCE	BOCE	BOCE	BOCE	BOCE	BOCE
Bucket capacity	m ³ 3.5	3.5	4.0	4.0	4.5	4.5
Specific material density	t/m ³ 0.85	0.8	0.85	0.8	0.85	0.8
Bucket width	mm 2,700	2,700	2,700	2,700	2,700	2,700
A Dumping height at max. lift height	mm 3,170	3,080	3,135	3,060	3,050	2,985
E Max. operating height	mm 5,880	5,970	6,060	6,160	6,170	6,280
F Reach at maximum lift height	mm 1,180	1,270	1,275	1,340	1,360	1,420
L Overall length	mm 8,310	8,450	8,420	8,530	8,540	8,640
Tipping load, straight*	kg 7,400	6,800	8,730	8,200	9,800	9,240
Tipping load, fully articulated*	kg 6,280	5,720	7,450	6,920	8,350	7,820
Operating weight*	kg 13,750	14,190	14,990	15,420	15,900	16,330
Tyre size	20.5R25 L3		20.5R25 L3		20.5R25 L3	



Light material density

	L 526	L 538	L 546
	ZK-QH	ZK-QH	ZK-QH
Geometry			
Cutting tools	BOCE	BOCE	BOCE
Bucket capacity	m ³ 4.5	5.5	6.5
Specific material density	t/m ³ 0.5	0.5	0.5
Bucket width	mm 2,700	2,700	2,700
A Dumping height at max. lift height	mm 2,925	2,850	2,730
E Max. operating height	mm 6,210	6,440	6,625
F Reach at maximum lift height	mm 1,430	1,555	1,680
L Overall length	mm 8,670	8,830	8,995
Tipping load, straight*	kg 6,610	7,900	8,900
Tipping load, fully articulated*	kg 5,540	6,610	7,450
Operating weight*	kg 14,350	15,650	16,650
Tyre size	20.5R25 L3		20.5R25 L3

* The figures shown include the above tyres, all lubricants, a full fuel tank, the ROPS/FOPS cab and the operator. Different tyres and optional equipment will change the operating weight and tipping load. (Tipping load, fully articulated according to ISO 14397-1)

For wheel loaders with large light material buckets and high-dump buckets or log grapples, we supply visual aids such as mirrors or cameras for front area monitoring that meet the requirements of the ISO 5006:2017 field of vision test.

ZK = Z-bar linkage
 ZK-QH = Z-bar linkage incl. quick hitch
 BOCE = Bolt-on cutting edge

Attachment

High-Dump bucket

L 526 – L 546

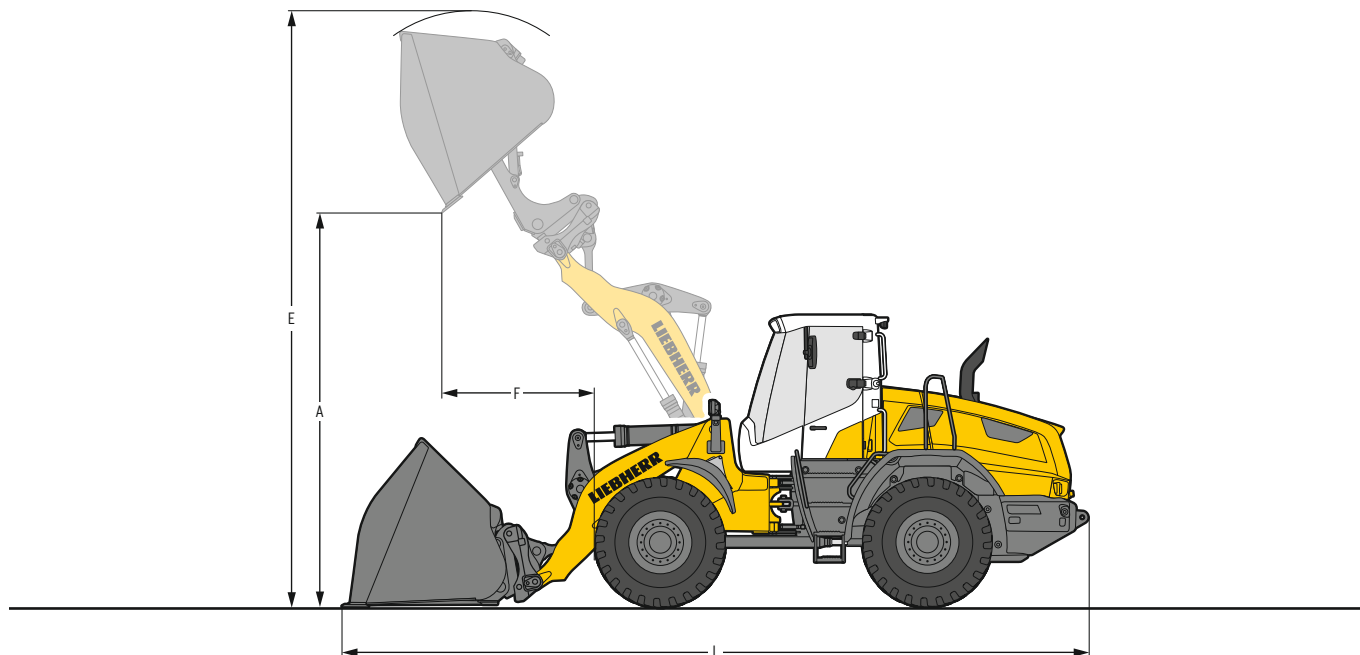

Heavy material density

	L 526		L 538		L 546	
	ZK	ZK-QH	ZK	ZK-QH	ZK	ZK-QH
Geometry						
Cutting tools	BOCE	BOCE	BOCE	BOCE	BOCE	BOCE
Bucket capacity	m ³ 3.0	3.0	3.5	3.5	4.0	4.0
Specific material density	t/m ³ 1.1	1.05	1.1	1.05	1.1	1.05
Bucket width	mm 2,700	2,700	2,700	2,700	2,700	2,700
A Dumping height at max. lift height	mm 4,495	4,600	4,550	4,680	4,490	4,605
E Max. operating height	mm 6,210	6,350	6,360	6,550	6,450	6,600
F Reach at maximum lift height	mm 1,280	1,350	1,430	1,470	1,510	1,560
L Overall length	mm 7,900	8,030	8,060	8,140	8,160	8,260
Tipping load, straight*	kg 8,700	8,100	9,800	9,300	11,100	10,500
Tipping load, fully articulated*	kg 7,350	6,830	8,340	7,860	9,390	8,850
Operating weight*	kg 14,110	14,460	15,440	15,780	16,350	16,700
Tyre size	20.5R25 L3		20.5R25 L3		20.5R25 L3	



Light material density

	L 526	L 538	L 546
	ZK-QH	ZK-QH	ZK-QH
Geometry			
Cutting tools	BOCE	BOCE	BOCE
Bucket capacity	m ³ 5.0	6.0	7.0
Specific material density	t/m ³ 0.5	0.5	0.5
Bucket width	mm 2,700	2,700	3,000
A Dumping height at max. lift height	mm 4,360	4,385	4,365
E Max. operating height	mm 6,660	6,910	6,950
F Reach at maximum lift height	mm 1,560	1,750	1,770
L Overall length	mm 8,300	8,510	8,540
Tipping load, straight*	kg 8,100	9,130	10,400
Tipping load, fully articulated*	kg 6,780	7,680	8,720
Operating weight*	kg 14,590	15,930	16,880
Tyre size	20.5R25 L3		20.5R25 L3

* The figures shown include the above tyres, all lubricants, a full fuel tank, the ROPS/FOPS cab and the operator. Different tyres and optional equipment will change the operating weight and tipping load. (Tipping load, fully articulated according to ISO 14397-1)

For wheel loaders with large light material buckets and high-dump buckets or log grapples, we supply visual aids such as mirrors or cameras for front area monitoring that meet the requirements of the ISO 5006:2017 field of vision test.

ZK = Z-bar linkage

ZK-QH = Z-bar linkage incl. quick hitch

BOCE = Bolt-on cutting edge

Attachment

High lift arm/high dump bucket

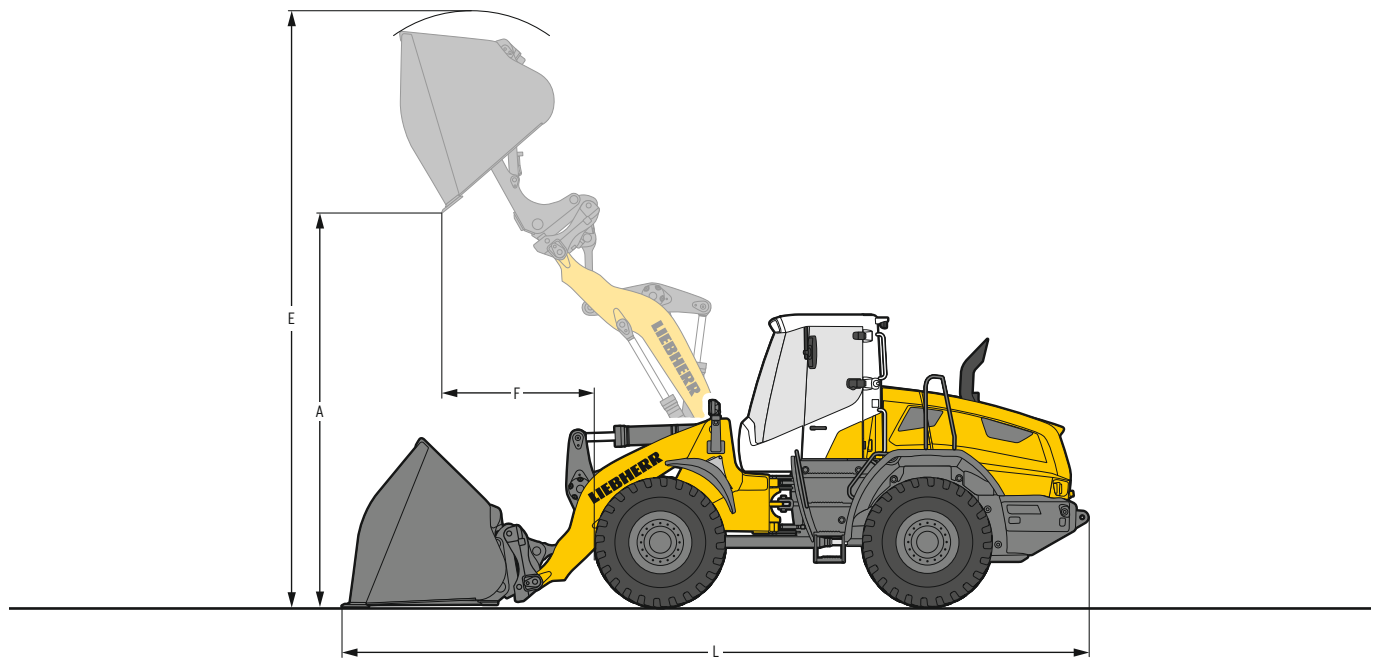

Heavy material density

	L 526		L 538		L 546	
Geometry	ZK	ZK-QH	ZK	ZK-QH	ZK	ZK-QH
Cutting tools	BOCE	BOCE	BOCE	BOCE	BOCE	BOCE
Bucket capacity	m ³ 3.0	3.0	3.5	3.5	4.0	4.0
Specific material density	t/m ³ 0.85	0.8	0.85	0.8	0.85	0.8
Bucket width	mm 2,700	2,700	2,700	2,700	2,700	2,700
A Dumping height at max. lift height	mm 5,090	5,200	5,090	5,220	5,030	5,145
E Max. operating height	mm 6,800	6,940	6,900	7,090	6,990	7,140
F Reach at maximum lift height	mm 1,230	1,300	1,285	1,325	1,365	1,420
L Overall length	mm 8,450	8,580	8,490	8,580	8,590	8,700
Tipping load, straight*	kg 6,600	6,100	8,000	7,540	9,100	8,600
Tipping load, fully articulated*	kg 5,490	5,030	6,740	6,300	7,640	7,160
Operating weight*	kg 14,420	14,770	15,650	15,990	16,560	16,910
Tyre size	20.5R25 L3		20.5R25 L3		20.5R25 L3	



Light material density

	L 526	L 538	L 546
Geometry	ZK-QH	ZK-QH	ZK-QH
Cutting tools	BOCE	BOCE	BOCE
Bucket capacity	m ³ 4.0	5.0	6.0
Specific material density	t/m ³ 0.5	0.5	0.5
Bucket width	mm 2,700	2,700	2,700
A Dumping height at max. lift height	mm 5,080	5,000	4,925
E Max. operating height	mm 7,070	7,300	7,440
F Reach at maximum lift height	mm 1,360	1,510	1,600
L Overall length	mm 8,660	8,825	8,945
Tipping load, straight*	kg 6,200	7,500	8,550
Tipping load, fully articulated*	kg 5,100	6,220	7,130
Operating weight*	kg 14,750	16,050	16,970
Tyre size	20.5R25 L3		20.5R25 L3

* The figures shown include the above tyres, all lubricants, a full fuel tank, the ROPS/FOPS cab and the operator. Different tyres and optional equipment will change the operating weight and tipping load. (Tipping load, fully articulated according to ISO 14397-1)

For wheel loaders with large light material buckets and high-dump buckets or log grapples, we supply visual aids such as mirrors or cameras for front area monitoring that meet the requirements of the ISO 5006:2017 field of vision test.

ZK = Z-bar linkage
 ZK-QH = Z-bar linkage incl. quick hitch
 BOCE = Bolt-on cutting edge

Attachment

Fork carrier and fork

L 526 – L 546

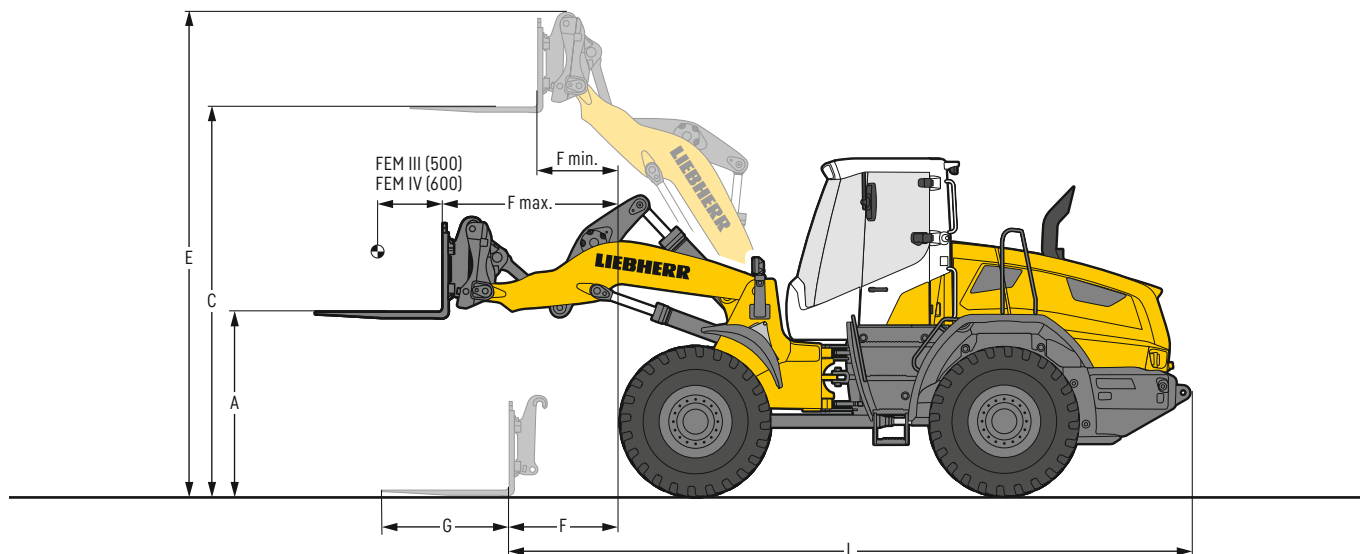

Fork carrier and fork

	L 526		L 538		L 546		L 538		L 546		
	STD	HL	STD	HL	STD	HL	STD	HL	STD	HL	
Fork	FEM III	FEM III	FEM III	FEM III	FEM III	FEM III	FEM IV	FEM IV	FEM IV	FEM IV	
Geometry	ZK-QH	ZK-QH	ZK-QH	ZK-QH	ZK-QH	ZK-QH	ZK-QH	ZK-QH	ZK-QH	ZK-QH	
Lift arm length	mm	2,550	3,000	2,650	3,000	2,650	3,000	2,650	3,000	2,650	3,000
A Lifting height at max. reach	mm	1,700	1,700	1,780	1,780	1,780	1,780	1,740	1,740	1,740	1,740
C Max. lifting height	mm	3,675	4,250	3,780	4,310	3,780	4,310	3,740	4,270	3,740	4,270
E Max. operating height	mm	4,605	5,190	4,705	5,250	4,705	5,250	4,740	5,285	4,740	5,285
F Reach at loading position	mm	1,030	1,590	1,070	1,510	1,070	1,510	1,090	1,530	1,090	1,530
F max. Max. reach	mm	1,640	2,080	1,710	2,050	1,710	2,050	1,690	2,030	1,690	2,030
F min. Reach at max. lifting height	mm	700	650	790	650	790	650	770	630	770	630
G Fork length	mm	1,200	1,200	1,200	1,200	1,200	1,200	1,500	1,500	1,500	1,500
L Length - basic machine	mm	6,590	7,150	6,670	7,120	6,670	7,120	6,700	7,140	6,700	7,140
Tipping load, straight*	kg	7,350	6,000	8,300	7,150	9,350	8,100	7,900	6,800	8,900	7,700
Tipping load, fully articulated*	kg	6,320	5,100	7,190	6,150	8,080	6,950	6,780	5,780	7,650	6,560
Recommended payload for uneven ground = 60 % of tipping load, articulated¹⁾	kg	3,750	3,000	4,300	3,650	4,800	4,150	4,000	3,450	4,550	3,900
Recommended payload for smooth surfaces = 80 % of tipping load, articulated¹⁾	kg	5,000 ²⁾	4,050	5,000 ²⁾	4,900	5,000 ²⁾	5,000 ²⁾	5,400	4,600	6,100	5,200
Operating weight*	kg	13,110	13,410	14,390	14,570	15,190	15,400	14,620	14,830	15,450	15,660
Tyre size		20.5R25 L3		20.5R25 L3		20.5R25 L3		20.5R25 L3		20.5R25 L3	

* The figures shown include the above tyres, all lubricants, a full fuel tank, the ROPS / FOPS cab and the operator. Different tyres and optional equipment will change the operating weight and tipping load. (Tipping load, fully articulated according to ISO 14397-1)

¹⁾ According to EN 474-3

²⁾ Payload is limited by FEM III fork carrier and forks to 5,000 kg

STD = Standard lift arm length

HL = High Lift

ZK-QH = Z-bar linkage incl. quick hitch

Attachment

Log grapple

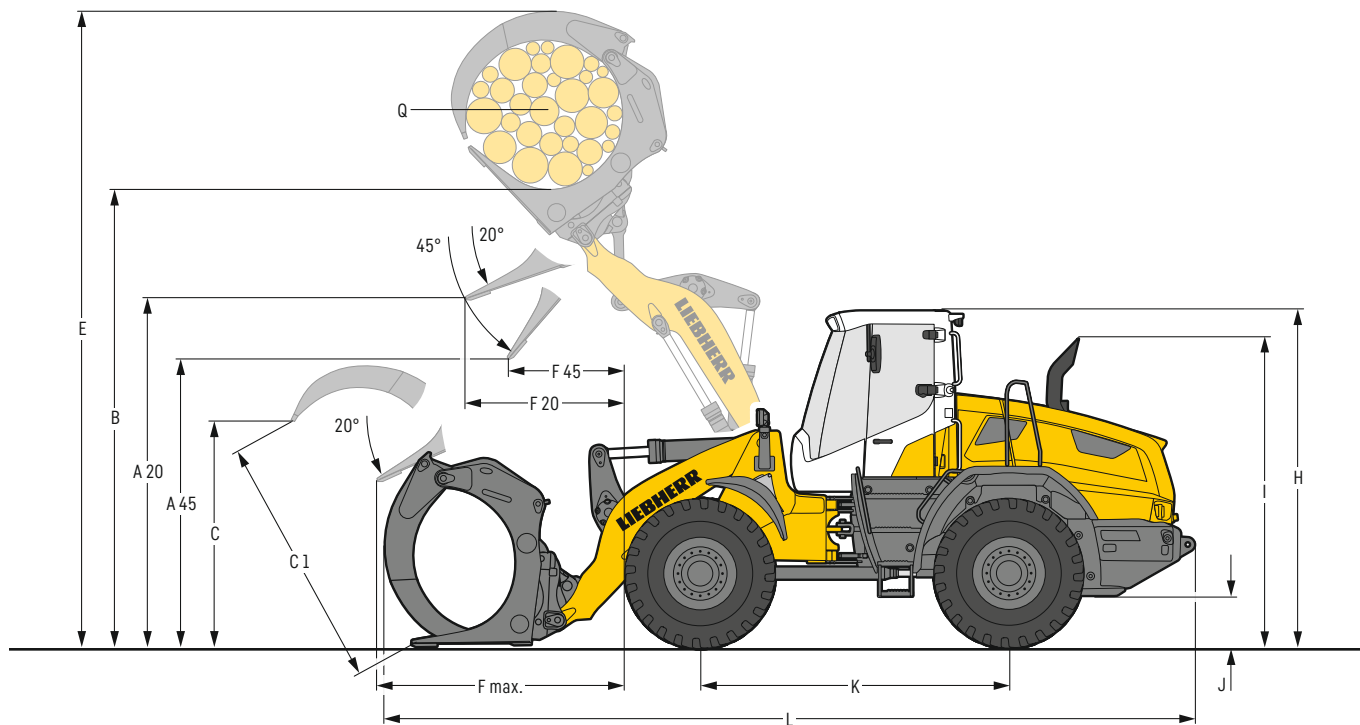

Log grapple

		L 526	L 538	L 546
Geometry		ZK-QH	ZK-QH	ZK-QH
A20	Discharge height at 20°	mm	3,205	3,260
A45	Discharge height at 45°	mm	2,785	2,790
B	Manipulation height	mm	4,290	4,440
C	Max. grapple opening in loading position	mm	1,910	2,395
C1	Max. grapple opening	mm	2,140	2,590
E	Max. height	mm	5,840	6,240
F20	Reach at max. lifting height at 20° discharge	mm	1,425	1,650
F45	Reach at max. lifting height at 45° discharge	mm	1,035	1,230
F max.	Max. reach	mm	2,360	2,575
H	Height above operator's cab ¹⁾	mm	3,250	3,250
I	Height above exhaust	mm	2,950	2,950
J	Ground clearance	mm	440	430
K	Wheelbase	mm	2,975	3,025
L	Overall length	mm	7,720	7,950
	Width over tyres	mm	2,480	2,480
Q	Grapple diameter	m ²	1.3	1.8
	Grapple width	mm	1,600	1,600
	Payload*	kg	3,400	4,100
	Operating weight*	kg	13,900	15,290
	Tyre size		20.5R25 L3	20.5R25 L3

* The figures shown include the above tyres, all lubricants, a full fuel tank, the ROPS / FOPS cab and the operator. Different tyres and optional equipment will change the operating weight and tipping load. (Tipping load, fully articulated according to ISO 14397-1)

For wheel loaders with large light material buckets and high-dump buckets or log grapples, we supply visual aids such as mirrors or cameras for front area monitoring that meet the requirements of the ISO 5006:2017 field of vision test.

¹⁾ With the optional "comfort safety door (can be opened 180°)", the "H" value increases by 130 mm when door is open.

ZK-QH = Z-bar linkage incl. quick hitch

Bucket selection

L 526 - L 546

L 526

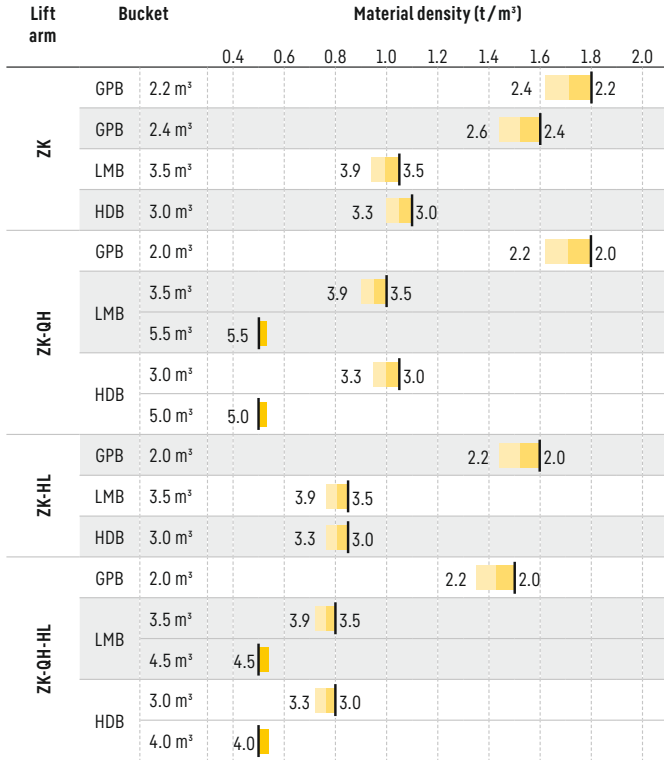

L 538

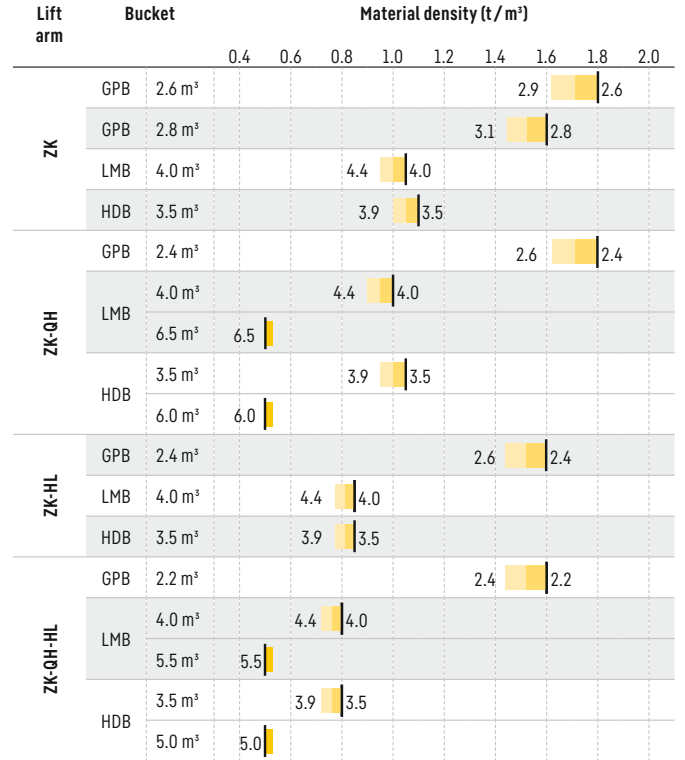

L 546

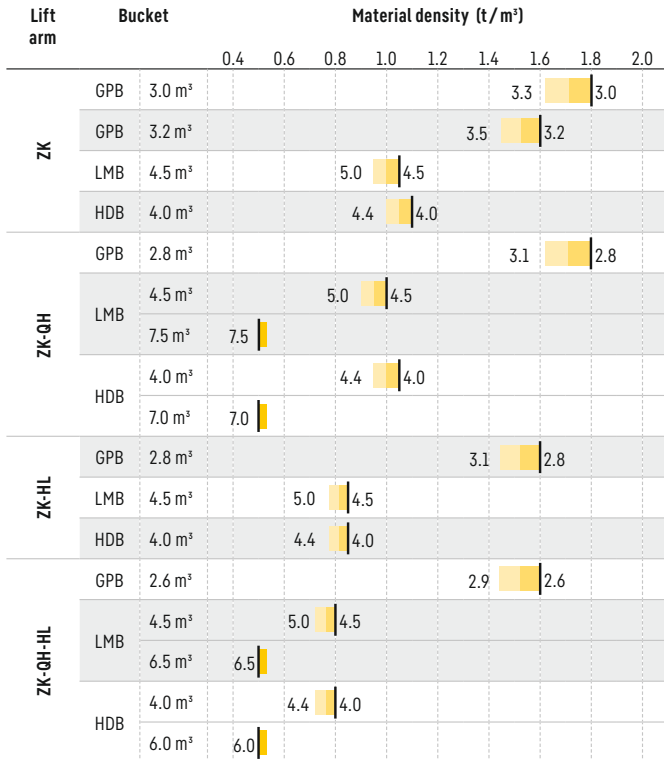

Bucket filling factor

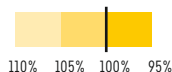

Lift arm

ZK	Z-bar linkage, standard lift arm length
ZK-QH	Z-bar linkage with quick hitch, standard lift arm length
ZK-HL	Z-bar linkage, High Lift
ZK-QH-HL	Z-bar linkage, with quick hitch, High Lift

Bucket

GPB	General purpose bucket (Excavation bucket)
LMB	Light material bucket
HDB	High-dump bucket

For wheel loaders with large light material buckets and high-dump buckets or log grapples, we supply visual aids such as mirrors or cameras for front area monitoring that meet the requirements of the ISO 5006:2017 field of vision test.

Bulk material densities and bucket filling factors

		t/m ³	%			t/m ³	%			t/m ³	%
Gravel	moist	1,9	105	Earth	dry	1,3	115	Glass waste	broken	1,4	100
	dry	1,6	105		wet excavated	1,6	110		solid	1,0	100
	crushed stone	1,5	100	Topsoil		1,1	110	Compost	dry	0,8	105
Sand	dry	1,5	105	Basalt		1,95	100	wet	1,0	110	
	wet	1,9	110	Granite		1,8	95	Wood chips / Saw dust		0,5	110
Gravel and Sand	dry	1,7	105	Sandstone		1,6	100	Paper	shredded / loose	0,6	110
	wet	2,0	100	Slate		1,75	100	recovered paper / cardboard	1,0	110	
Sand / Clay		1,6	110	Bauxite		1,4	100	Coal	heavy material density	1,2	110
Clay	natural	1,6	110	Limestone		1,6	100	light material density	0,9	110	
	dry	1,4	110	Gypsum	broken	1,8	100	Waste	domestic waste	0,5	100
Clay / Gravel	dry	1,4	110	Coke		0,5	110	bulky waste	1,0	100	
	wet	1,6	100	Slag	broken	1,8	100				

Tipping load



What is tipping load?

Load at centre of gravity of working equipment, so that the wheel loader just begins to tip over the front axle. This is the most unfavourable static-load position for the wheel loader. Lifting arms horizontal, wheel loader fully articulated at centre pivot.

Pay load.

The pay load must not exceed 50 % of the tipping load when articulated. This is equivalent to a static stability-margin factor of 2.0.

Bucket capacity.

The bucket volume is determined from the pay load.

$$\text{Pay load} = \frac{\text{Tipping load, articulated}}{2}$$

$$\text{Bucket capacity} = \frac{\text{Pay load (t)}}{\text{Specific bulk weight of material (t/m}^3\text{)}}$$

Tyres



Tyre types

	Size and tread code		Change of operating weight kg	Width over tyres mm	Change in vertical dimensions* mm	Use
L 526						
Bridgestone	17.5R25	VJT L3	- 394	2,440	- 44	Bulk material (firm ground conditions)
Bridgestone	17.5R25	VSDL L5	119	2,450	- 5	Stone, Scrap, Recycling (firm ground conditions)
Bridgestone	20.5R25	VJT L3	17	2,480	8	Bulk material (firm ground conditions)
Bridgestone	20.5R25	VSDL L5	680	2,480	60	Stone, Scrap, Recycling (firm ground conditions)
Bridgestone	20.5R25	VSDR L5	688	2,480	60	Stone, Scrap, Recycling (firm ground conditions)
Bridgestone	550/65R25	VTS L3	- 132	2,500	- 50	Gravel (all ground conditions)
Bridgestone	650/65R25	VTS L3	605	2,650	16	Gravel (all ground conditions)
Continental	20.5R25	EM-Master L3	166	2,480	26	Bulk material (firm ground conditions)
Goodyear	17.5R25	TL-3A+ L3	- 252	2,460	- 39	Sand, Gravel, Earthworks, Clay (all ground conditions)
Goodyear	17.5R25	RL-5K L5	160	2,460	- 20	Stone, Scrap, Recycling (firm ground conditions)
Goodyear	20.5R25	TL-3A+ L3	156	2,500	11	Sand, Gravel, Earthworks, Clay (all ground conditions)
Goodyear	20.5R25	GP-4D L4	328	2,470	20	Gravel, Industry, Wood (firm ground conditions)
Goodyear	20.5R25	RL-5K L5	752	2,500	49	Stone, Scrap, Recycling (firm ground conditions)
Michelin	17.5R25	XTLA L2	- 555	2,460	- 44	Gravel, Earthworks, Clay (all ground conditions)
Michelin	17.5R25	XHA2 L3	- 528	2,460	- 61	Sand, Gravel (all ground conditions)
Michelin	17.5R25	XLD D2A L5	- 232	2,460	- 25	Stone, Mining spoil (firm ground conditions)
Michelin	17.5R25	X MINE PRO L5	32	2,490	- 17	Stone, Scrap, Recycling (firm ground conditions)
Michelin	20.5R25	XTLA L2	- 121	2,480	- 7	Gravel, Earthworks, Clay (all ground conditions)
Michelin	20.5R25	XHA2 L3	0	2,480	0	Sand, Gravel (all ground conditions)
Michelin	20.5R25	XLD D2A L5	431	2,480	30	Stone, Mining spoil (firm ground conditions)
Michelin	20.5R25	X MINE PRO L5	616	2,510	48	Stone, Scrap, Recycling (firm ground conditions)
Michelin	550/65R25	XLD65 L3	- 82	2,500	- 44	Gravel (all ground conditions)
Michelin	650/65R25	XLD65 L3	488	2,640	- 7	Gravel (all ground conditions)
Nokian	17.5R25	Hakkapeliitta L2	- 488	2,450	- 51	Winter tyres, Gravel, Asphalt (all ground conditions)
Nokian	20.5R25	Hakkapeliitta L2	- 104	2,490	6	Winter tyres, Gravel, Asphalt (all ground conditions)
L 538 / L 546						
Bridgestone	20.5R25	VJT L3	17	2,480	8	Bulk material (firm ground conditions)
Bridgestone	20.5R25	VSDL L5	680	2,480	60	Stone, Scrap, Recycling (firm ground conditions)
Bridgestone	20.5R25	VSDR L5	688	2,480	60	Stone, Scrap, Recycling (firm ground conditions)
Bridgestone	550/65R25	VTS L3	- 44	2,500	- 50	Gravel (all ground conditions)
Bridgestone	650/65R25	VTS L3	595	2,650	16	Gravel (all ground conditions)
Continental	20.5R25	EM-Master L3	156	2,480	26	Bulk material (firm ground conditions)
Goodyear	20.5R25	TL-3A+ L3	156	2,500	11	Sand, Gravel, Earthworks, Clay (all ground conditions)
Goodyear	20.5R25	GP-4D L4	328	2,470	20	Gravel, Industry, Wood (firm ground conditions)
Goodyear	20.5R25	RL-5K L5	752	2,500	49	Stone, Scrap, Recycling (firm ground conditions)
Michelin	20.5R25	XTLA L2	- 121	2,510	- 7	Gravel, Earthworks, Clay (all ground conditions)
Michelin	20.5R25	XHA2 L3	0	2,480	0	Sand, Gravel (all ground conditions)
Michelin	20.5R25	XLD D2A L5	431	2,480	30	Stone, Mining spoil (firm ground conditions)
Michelin	20.5R25	X MINE PRO L5	606	2,510	48	Stone, Scrap, Recycling (firm ground conditions)
Michelin	550/65R25	XLD65 L3	- 82	2,500	- 44	Gravel (all ground conditions)
Michelin	650/65R25	XLD65 L3	478	2,640	- 7	Gravel (all ground conditions)
Nokian	20.5R25	Hakkapeliitta L2	- 114	2,490	6	Winter tyres, Gravel, Asphalt (all ground conditions)

* The stated values are theoretical and may deviate in practice.

Before operating the vehicle with tyre foam filling or tyre protection chains, please discuss this with the Liebherr-Werk Bischofshofen GmbH.

The Liebherr wheel loaders

Wheel loader



		L 504 Compact	L 506 Compact	L 507 Stereo	L 508 Compact	L 509 Stereo	L 514 Stereo
Tipping load	kg	3,000	3,500	3,750	3,900	4,430	5,750
Bucket capacity	m ³	0.7	0.8	0.9	1.0	1.2	1.5
Operating weight	kg	4,600	4,970	5,550	5,700	6,390	8,860
Engine output	kW / HP	34 / 46	47,5 / 64	50 / 68	47,5 / 64	54 / 73	76 / 103

Wheel loader



		L 518 Stereo	L 526	L 538	L 546	L 550 XPower
Tipping load	kg	6,550	8,730	9,650	11,010	12,500
Bucket capacity	m ³	1.7	2.2	2.6	3.0	3.4
Operating weight	kg	9,190	13,170	14,520	15,410	18,550
Engine output	kW / HP	76 / 103	116 / 158	129 / 175	138 / 188	163 / 222

Wheel loader



		L 556 XPower	L 566 XPower	L 576 XPower	L 580 XPower	L 586 XPower
Tipping load	kg	13,750	15,900	17,600	19,200	21,600
Bucket capacity	m ³	3.7	4.2	4.7	5.2	6.0
Operating weight	kg	19,600	23,900	25,700	27,650	32,600
Engine output	kW / HP	183 / 249	203 / 276	218 / 296	233 / 317	263 / 358

02.22

Environmental protection can help you earn money!



Always in fuel saving mode with the Liebherr fuel-saving calculator

100% power output with up to 30% less fuel consumption – the Liebherr fuel saving calculator shows how much fuel can be saved compared to similar machines. The online application is available free of charge and provides a quick and simple overview of fuel savings per year in euros. The calculation is based on average fuel consumption, operating hours per year and the current fuel price. The potential savings when operating a Liebherr wheel loader are impressive – see for yourself!

	Ø Litres / hour*
L 526: 2.2 m ³	5.92
L 538: 2.6 m ³	6.53
L 546: 3.0 m ³	7.51
L 550: 3.4 m ³	9.59
L 556: 3.7 m ³	10.63
L 566: 4.2 m ³	12.79
L 576: 4.7 m ³	13.69
L 580: 5.2 m ³	14.31
L 586: 6.0 m ³	17.56

* Wheel loader in operation with a customer-specific machine design.
Averages data from MyLiebherr Performance, calculated on 19/11/2024.



Experience just how much fuel you can save!
www.encyplus.liebherr.com

Equipment

 Basic wheel loader	L 526	L 538	L 546
Adjustable plastic mudguard	+	+	+
Air pre-cleaner TOP AIR	+	+	+
Automatic central lubrication system Liebherr	+	+	+
Automatic delayed engine stop (5 min.)	+	+	+
Automatic engine shutdown (after 5 minutes at idle speed < 1,000 rpm)	+	+	+
Auxiliary heater (Additional heating with engine preheating)	+	+	+
Combined inching-braking system	●	●	●
Complete drive shaft protection	+	+	+
Cooling water pre-heating 230 V	+	+	+
Crash protection, rear	+	+	+
Crash protection, rear with guard	+	+	+
Desingn exhaust tail pipe in stainless steel	+	+	+
Electr. equipment for sweeper (socket for sweeper)	+	+	+
Electronic tractive force regulation for difficult ground conditions	●	●	●
External jump starter equipment	+	+	+
Fire extinguisher 6 kg	+	+	+
Fluff trap for radiator	+	+	+
Fuel pre-filter	●	●	●
Fuel pre-filter with pre-heating	+	+	+
Guard for headlights	+	+	+
Integrated tyre pressure monitoring system	+	+	+
Large-mesh radiator	+	+	+
Liebherr biodegradable hydraulic oil	+	+	+
Liebherr weighing system with "Truck Payload Assist" (cannot be certified as a regulated weights and measure device)	+	+	+
Mudguard in plastic design	●	●	●
Multi-disc limited slip differentials in both axles	●	●	●
Plastic diesel exhaust fluid tank	●	●	●
Plastic wheel case flare	+	+	+
Rear license panel light	+	+	+
Reversible fan drive	+	+	+
Ride control	+	+	+
SCR technology incl. diesel particle filter	●	●	●
Speed limiter 20 km/h	+	+	+
Steel design adjustable wheel case flare	+	+	+
Steel fuel tank	+	+	+
Steel mudguard	+	+	+
Toolbox with toolkit	+	+	+
Tow hitch	●	●	●
Travel light (with additional headlights) on front section halogen	+	+	+
Travel light (with additional headlights) on front section LED	+	+	+
Travel light on front section - halogen	●	●	●
Travel light on front section - LED	+	+	+

 Equipment	L 526	L 538	L 546
1st and 2nd hydraulic additional function on the front incl. lines	+	+	+
1st hydraulic additional function on the front incl. lines	+	+	+
Adjustable tipping speed	●	●	●
Automatic lift arm position and lowering programmable	●	●	●
Automatic return high dump bucket	+	+	+
Bucket bearing seal (standard)	●	●	●
Bucket return-to-dig (automatic and programmable)	●	●	●
Bucket return-to-dig via button	+	+	+
Bucket tilt assistant	+	+	+
Continuous mode, additional function	+	+	+
Float position	●	●	●
Fork carrier and pallet forks	+	+	+
High-dump bucket	+	+	+
Hydraulic quick change device preparation Solidlink	+	+	+
Hydraulic quick hitch	+	+	+
Hydraulic quick hitch Solidlink	+	+	+
Lift arms 2,550 mm	●	-	-
Lift arms 2,650 mm	-	●	●
Lift arms 3,000 mm	+	+	+
Light material bucket	+	+	+
Log grapple	+	+	+
Pipe break protection (lift and tilt cylinders)	+	+	+
Pressure relief for hydraulic additional function	●	●	●
Stroke limit damping	+	+	+
Sweeper mode	+	+	+
Tilt cylinder protection	+	+	+
Visualisation of the equipment position	●	●	●
Working hydraulics lockout	●	●	●

Equipment



Operator's cab

	L 526	L 538	L 546
Access assistance to facilitate cleaning windscreen	●	●	●
Adapter plate for additional fastening on the multi-function rail	●	●	●
Adaptive working lighting	+ + +		
Air conditioning system	+ + +		
Amber beacon swiveling LED	+ + +		
Automatic air conditioning system	+ + +		
Automatic driver identification	+ + +		
Beacon activation in reverse travel	+ + +		
Button-operated horn via right button	+ + +		
Cigarette lighter	●	●	●
Clothes hook	●	●	●
Comfort Grammer operator's seat with longitudinal absorption, seat heating and 2-point seatbelt	●	●	●
Comfort Grammer operator's seat with longitudinal absorption, seat heating and 3-point seatbelt	+ + +		
Comfort Grammer operator's seat with longitudinal absorption, seat heating and 4-point seatbelt	+ + +		
Comfort safety door (open through 180°)	+ + +		
Cool box	+ + +		
Electronical theft protection with code	+ + +		
Electronical theft protection with key	+ + +		
Emergency steering pump	●	●	●
Exterior mirror, electrical adjustable, with heating	+ + +		
Exterior mirrors, folding and heated	+ + +		
Fire extinguisher in cab 2 kg	+ + +		
First aid kit	●	●	●
Floor mat	●	●	●
Folding exterior mirror	●	●	●
Head rest	+ + +		
Headlights activation (on the cab) for reverse travel	+ + +		
Headlights activation for reverse travel (on the cab)	+ + +		
Headlights front, double design, halogen	●	●	●
Headlights front, double design, LED	+ + +		
Headlights rear, double design, halogen	+ + +		
Headlights rear, double design, LED	+ + +		
Headlights rear, single design, halogen	+ + +		
Headlights rear, single design, LED	+ + +		
Headlights rear, triple design, LED	+ + +		
Hinged window (left)	+ + +		
Interior mirror left	●	●	●
Joystick steering	+ + +		
Joystick steering only	+ + +		
Liebherr Connect			
MyLiebherr Maintenance	+ + +		
MyLiebherr Performance	+ + +		
MyLiebherr Portal*	●	●	●
Liebherr control lever with buttons	●	●	●
Liebherr control lever with mini-joystick	+ + +		
Manual driver identification	+ + +		
Multifunctional rail, right	●	●	●



Operator's cab

	L 526	L 538	L 546
operating hour meter (mechanic)	+ + +		
Operation with multi-lever control	+ + +		
Particle filter F7	●	●	●
Power socket 12V	●	●	●
Premium Grammer operator's seat with longitudinal and transverse absorption, seat climate control, and 2-point seatbelt	+ + +		
Premiumdisplay (Touchscreen), with height adjustment and tilting function	●	●	●
Preparation for dust filtrating device	+ + +		
Preparation for protective ventilation device	+ + +		
Preparation for radio installation	+ + +		
Radio "Comfort" (DAB+ / USB / AUX / BLUETOOTH / handsfree set)	+ + +		
Radio "Standard"	+ + +		
Radio unit installation (preparation)	+ + +		
Rear window heated electrically	●	●	●
Seat belt warning device (visual) - green warning flashlight on cab	+ + +		
Sliding window right	●	●	●
Slipcover for operator seat	+ + +		
Soundproof ROPS / FOPS cab	●	●	●
Speed limit & fixed speed	+ + +		
Steering column folding	●	●	●
Steering column height-adjustable	+ + +		
Sunblind front	+ + +		
Sunblind rear	+ + +		
USB charging port	+ + +		
V _{max} speed limit adjustable via button on control unit	●	●	●
Wide angle mirror	+ + +		
Windscreen guard	+ + +		
Windscreen wiper single-sweep function with button	+ + +		
Wipe and wash system	●	●	●



Safety

	L 526	L 538	L 546
Active personnel detection at the rear	+ + +		
Back-up alarm (acoustical)	+ + +		
Custom paintwork	+ + +		
Main battery switch (lockable)	+ + +		
Rear space monitoring with camera	●	●	●
Reversing alarm LED warning flashlight (visual) (adjustable to 0 - constant - reverse travel)	+ + +		
Roof camera for front area monitoring	+ + +		
Skyview 360°	+ + +		
Standard parking brake	●	●	●

- = Standard
- + = Option
- = not available
- * = activation required free of charge

Further information can be found in the brochure "Assistance systems for wheel loaders" or you can find here:



Here you can download our wheel loader brochures:



