A 916 Compact Litronic

LIEBHERR

Wheeled excavator



Generation
8

Operating weight
16,100–17,800 kg

Engine
110 kW / 150 HP
Stage V
Tier 4 Final

Bucket capacity
0.17–0.87 m³

Compact wheeled excavators at a glance

Innovative cab design meets intuitive controls

- Newly developed cab with advanced intuitive operating and dual display concept INTUSI
 - 10" main display and haptic user feedback
 - 3.5" display with additional user interface for prio functions
- Smart functions such as personalisable operation and advanced hot-key navigation
- Integration of assistance systems in a user interface
- Intuitive control and feedback logic
- Customisable joystick configurations
- Proportional control with 4-way mini-joystick
- Large glass surfaces for a more direct view of the work area
- More legroom thanks to longer cab
- Convenient radio operation with hands-free system
- Automatic air conditioning (as standard)
- Powerful LED headlights (as standard)
- Joystick steering (optional)
- Comfort/Premium operator's seat (optional)
- Top and front protective guards, foldable (optional)

Optimally designed and laid out equipment for maximum reliability

- Various boom versions and stick lengths
- Liebherr hydraulic cylinders
- Pipe fracture safety valves for hoist and stick cylinders
- Overload warning system (as standard)
- Ride control (optional)
- Liebherr quick coupling systems (optional)
- Wide selection of Liebherr attachments (optional)





Superior technology for highest economy

- Liebherr diesel engine complies with emission stage V
- Exhaust gas treatment with Liebherr-SCRT technology
- Liebherr-Power-Efficiency (LPE)
- Load sensing control
- Selection of different operating modes (Sensitive, ECO, Power, Power-Plus)
- Sensor-controlled low idle automatic

Sophisticated maintenance concept for maximum productivity

- Fully automatic central lubrication system for upper-carriage and equipment
- Large, wide-opening service doors
- Central maintenance points, including air filter and wiper water on the cab, easily accessible from the ground

Perfect combination for maximum performance

- Short tail radius
- Different stabilization variants available, welded on
- Liebherr tyres without intermediate ring
- Travel drive integrated in undercarriage
- Automatic digging brake

Next-generation assistance systems

- Seamless bird's eye view of the machine environment with Skyview 360°
- Higher productivity through precise control of the working plane with 2D and 3D machine control
- More comfortable working in confined spaces with the Advanced working envelope limitation
- MiC 4.0 BUS enables cross-manufacturer communication between construction machines and attachments



Technical data



Diesel engine

Rating per ISO 9249	110kW (150HP) at 1,800RPM
Model	D924 - FPT motor designed for Liebherr
Type	4 cylinder in-line
Bore / Stroke	104 / 132 mm
Displacement	4.5 l
Engine operation	4-stroke diesel Common-Rail Turbo-charged and after-cooled Reduced emissions
Air cleaner	Dry-type air cleaner with pre-cleaner, primary and safety elements
Engine idling	Sensor controlled
Electrical system	
Voltage	24 V
Batteries	2 x 145 Ah / 12 V
Alternator	Three-phase current 28 V / 140 A
Stage V	
Harmful emissions values	According to regulation (EU) 2016/1628
Emission control	Liebherr-SCR technology
Fuel tank	243 l
Urea tank	46 l
Tier 4 Final	
Harmful emissions values	In accordance with 40CFR1039 (EPA) / 13CCR (CARB)
Emission control	Liebherr-SCR technology
Option	Liebherr particle filter
Fuel tank	243 l
Urea tank	46 l



Cooling system

Diesel engine	Water-cooled Compact cooling system consisting cooling unit for water, hydraulic oil and charge air with stepless thermostatically controlled fan, fans for radiator cleaning can be completely folded away
----------------------	--



Hydraulic controls

Power distribution	Via control valves with integrated safety valves, simultaneous and independent actuation of chassis, swing drive and equipment
Servo circuit	
Equipment and swing	With electro-hydraulic pilot control and proportional joystick levers
Chassis	Electro-proportional via foot pedal
Additional functions	Via switch or electro-proportional foot pedals
Proportional control	Proportionally acting transmitters on the joysticks for additional hydraulic functions



Hydraulic system

Hydraulic pump	Liebherr axial piston variable displacement pump
For equipment and travel drive	
Max. flow	300 l/min.
Max. pressure	350 bar / PowerLift 375 bar
Hydraulic pump regulation and control	Liebherr-Synchron-Comfort-system (LSC) with electronic engine speed sensing regulation, pressure and flow compensation, torque controlled swing drive priority
Hydraulic tank	135 l
Hydraulic system	max. 300 l
Filtration	1 main return filter with integrated partial micro filtration (10 µm)
MODE selection	Adjustment of engine and hydraulic performance via a mode pre-selector to match application, e.g. for especially economical and environmentally friendly operation or for maximum digging performance and heavy-duty jobs
S (Sensitive)	Mode for precision work and lifting through very sensitive movements
E (Eco)	Mode for especially economical and environmentally friendly operation
P (Power)	Mode for high performance with low fuel consumption
P+ (Power-Plus)	Mode for highest performance and for very heavy duty applications, suitable for continuous operation
Engine speed and performance setting	Stepless alignment of engine output and hydraulic power via engine speed
Option	Tool Control: 20 pre-adjustable pump flows and pressures for add-on attachments



Swing drive

Drive	Liebherr axial piston motor with integrated brake valve and torque control, Liebherr planetary reduction gear
Swing ring	Liebherr, sealed race ball bearing swing ring, internal teeth
Swing speed	0-10.0 RPM stepless
Swing torque	54 kNm
Holding brake	Wet multi-disc (spring applied, pressure released)
Option	Positioning swing brake automatic and manual Positioning swing brake automatic

Cab

Cab	ROPS safety cab structure (roll-over protection system) with individual windscreens or featuring a slide-in subpart under the ceiling, headlights integrated in the ceiling, a door with a sliding window, large stowing and depositing possibilities, shock-absorbing suspension, sound damping insulating, laminated safety glass, separate window shades for the sunroof window and windscreen
Operator's seat Comfort	Air cushioned operator's seat with 3D-adjustable armrests, headrest, lap belt, seat heater (2-stage), adjustable seat cushion inclination and length, lockable horizontal suspension, automatic weight adjustment, pneumatic low frequency suspension, adjustable suspension stiffness, pneumatic lumbar vertebrae support and passive seat climatisation with active coal
Operator's seat Premium (Option)	In addition to operator's seat Comfort: active electronic weight adjustment (automatic readjustment) and active seat climatisation with active coal and ventilator
Arm consoles	Joysticks with control consoles attached to the seat, folding left control console
Operation and displays	Large high-resolution operating unit, intuitive, colour display with touchscreen, haptic feedback, video-compatible, numerous setting, control and monitoring options, e.g. air conditioning control, fuel consumption, machine and attachment parameters
Air-conditioning	Automatic air-conditioning, recirculated air function, fast de-icing and demisting at the press of a button, air vents can be operated via a menu; recirculated air and fresh air filters can be easily replaced and are accessible from the outside; heating-cooling unit, designed for extreme outside temperatures, sensors for solar radiation, inside and outside temperatures (country-dependent)
Refrigerant	R134a
Global warming potential	1,430
Quantity at 25 °C	1,300 g
CO₂ equivalent	1.859 t
Vibration emission*	
Hand / arm vibrations	< 2.5 m/s ²
Whole-body vibrations	< 0.5 m/s ²
Measuring inaccuracy	According with standard EN 12096:1997

Undercarriage

Drive	Oversized two speed power shift transmission with additional creeper speed, Liebherr axial piston motor with functional brake valve on both sides
Pulling force	127 kN
Travel speed	0- 3.5 km/h stepless (creeper speed off-road) 0- 7.0 km/h stepless (off-road) 0-13.0 km/h stepless (creeper speed on-road) 0-20.0 km/h stepless (road travel) 0-max. 30.0 or 37.0 km/h Speeder (option)
Driving operation	Automotive driving using accelerator pedal, cruise control function: storage of variable accelerator pedal positions, both off-road and on-road
Axles	Manual or automatic hydraulically controlled front axle oscillation lock
Service brake	Two circuit travel brake system with accumulator, wet and backlash-free disc brake
Automatic digging brake	Works automatically when driving off (accelerator pedal actuation) and when the machine is stationary (engagement); the digging brake engages automatically - can be coupled with automatic swing axle lock
Holding brake	Wet multi-disc (spring applied, pressure released)
Stabilization	Rear stabilizer blade (adjustable during travel for dozing) Rear outriggers + front stabilizer blade
Option	EW undercarriage 2.75 m / 9'

Equipment

Type	High-strength steel plates at highly-stressed points for the toughest requirements. Complex and stable mountings of equipment and cylinders
Hydraulic cylinders	Liebherr cylinders with special sealing and guide system and, depending on cylinder type, shock absorption
Bearings	Sealed, low maintenance

Complete machine

Lubrication	Liebherr central lubrication system for uppercarriage and equipment, automatically
Noise emission	
ISO 6396	71 dB(A) = L _{pA} (inside cab)
2000/14/EC	100 dB(A) = L _{WA} (surround noise)

* for risk assessment according to 2002/44/EC see ISO/TR 25398:2006

Dimensions

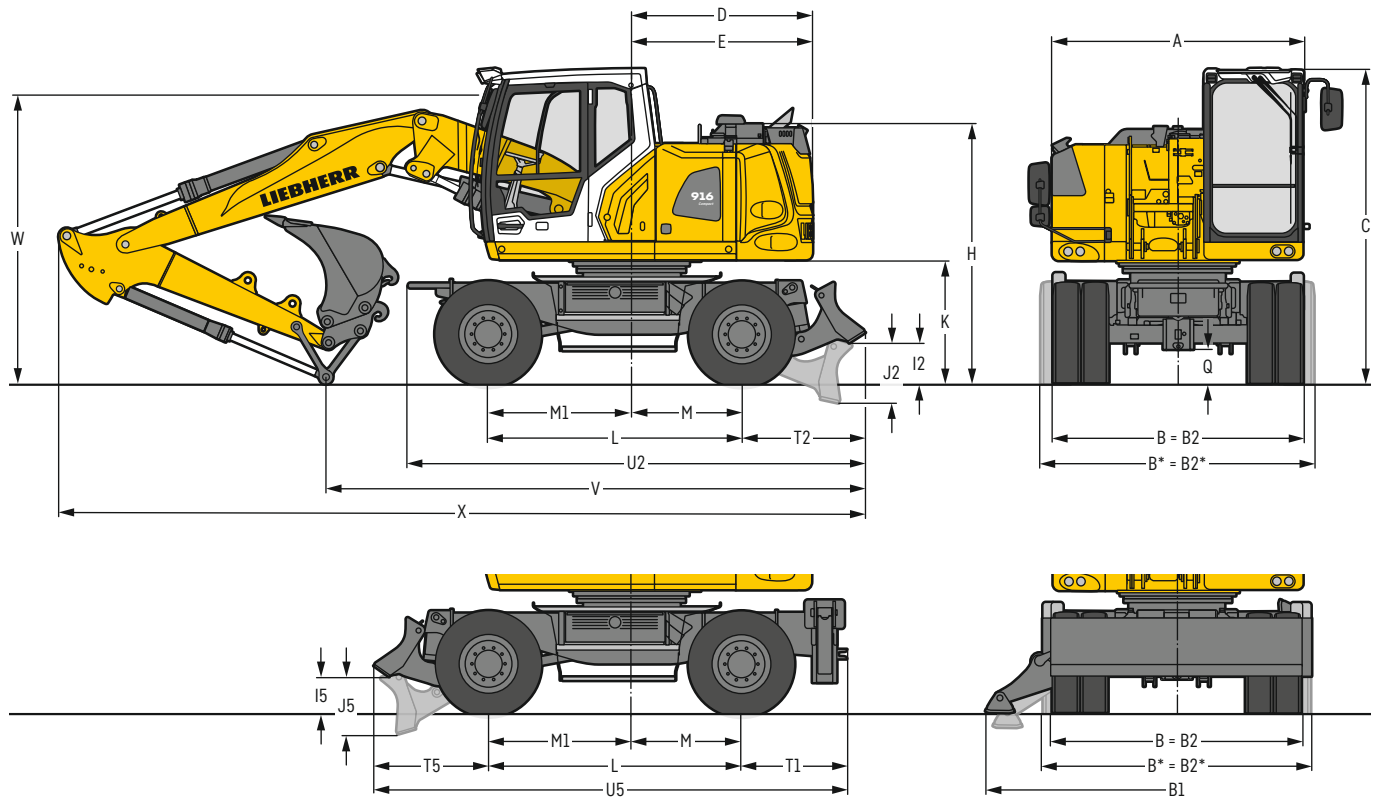

	mm
A	2,525
B	2,540
B*	2,710
B1	3,695
B2	2,540
B2*	2,750
C	3,160
D	1,800
E	1,800
H	2,600
I2	410
I5	370
J2	605
J5	580
K	1,205
L	2,540
M	1,100
M1	1,440
Q	340
T1	1,047
T2	1,230
T5	1,155
U2	4,575
U5	4,765

* EW undercarriage
E = Tail radius
Tyres 290/90-20

	Stick	Two-piece boom 4.85 m	
		Rear blade	Rear outriggers + front blade
	m	mm	mm
V	2.25	5,400	5,250
	2.45	5,050	5,350
	2.65	5,400	5,650
W	2.25	2,900	2,900
	2.45	2,850	2,850
	2.65	3,150	3,150
X	2.25	8,050	7,900
	2.45	8,050	8,350
	2.65	8,100	8,350

	Stick	Offset two-piece boom 4.90 m	
		Rear blade	Rear outriggers + front blade
	m	mm	mm
V	2.25	5,750	5,550
	2.45	5,400	5,650
	2.65	5,350	5,600
W	2.25	3,150	3,150
	2.45	3,100	3,100
	2.65	3,200	3,200
X	2.25	8,100	7,950
	2.45	8,150	8,400
	2.65	8,150	8,400

Dimensions are with equipment over steering axle
* Equipment over digging axle for shorter transport dimensions
W = Max. ground clearance including approx. 150mm piping

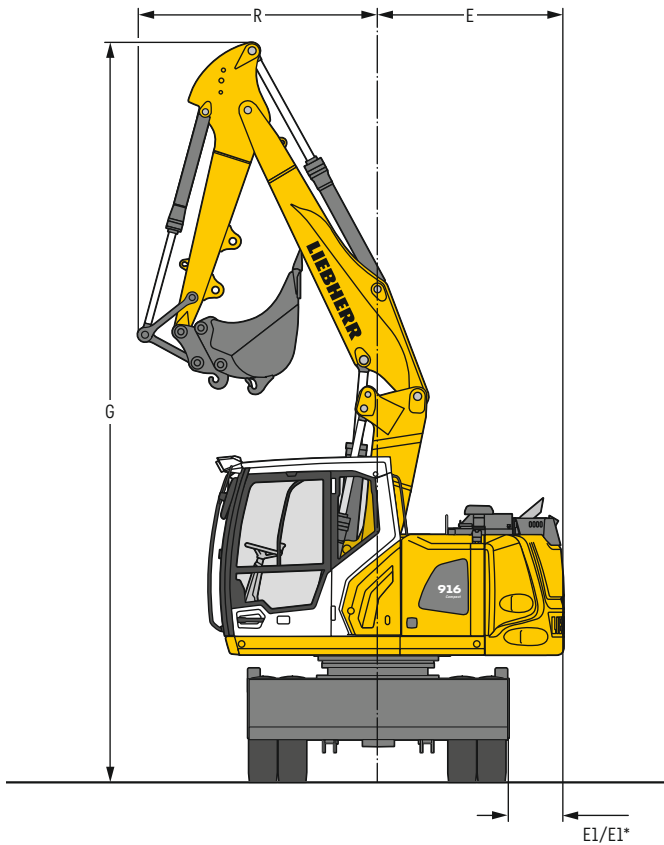

Boom	Stick	G	R	E	E1 / E1*
	m	mm	mm	mm	mm
Two-piece boom 4.85 m	2.25	7,180	2,185	1,800	530 / 425*
Two-piece boom 4.85 m	2.45	7,190	2,235	1,800	530 / 425*
Two-piece boom 4.85 m	2.65	7,190	2,235	1,800	530 / 425*

* EW undercarriage

Backhoe bucket

with two-piece boom 4.85 m

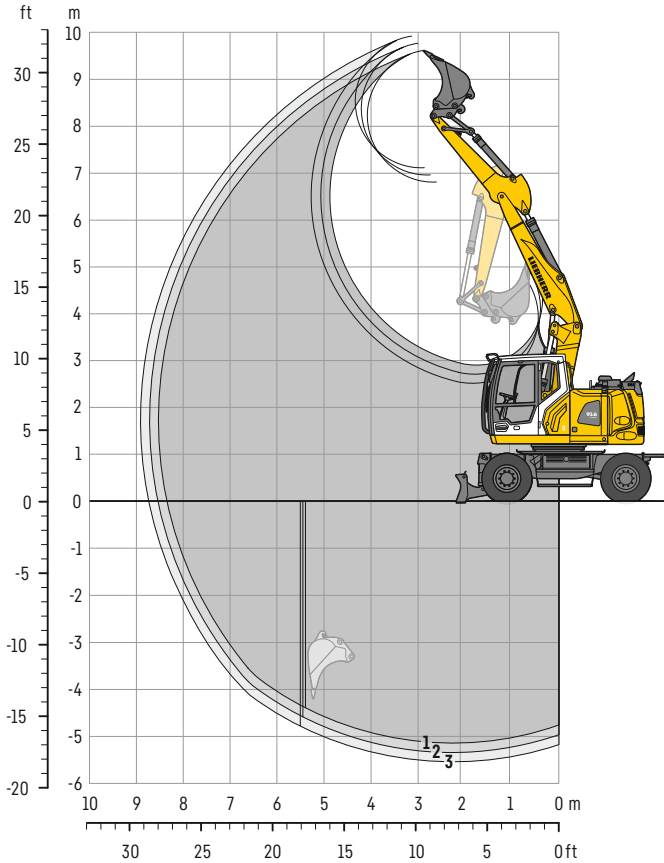

Digging envelope

with quick coupler	1	2	3	
Stick length	m	2.25	2.45	2.65
Max. digging depth	m	5.15	5.35	5.55
Max. reach at ground level	m	8.35	8.55	8.75
Max. dumping height	m	6.80	6.95	7.00
Max. teeth height	m	9.60	9.75	9.90
Min. equipment radius	m	2.17	2.22	2.26

Digging forces

without quick coupler with PowerLift function	1	2	3	
Max. digging force (ISO 6015)	kN	74.7	70.0	65.9
	t	7.6	7.1	6.7
Max. breakout force (ISO 6015)	kN	92.4	92.4	92.4
	t	9.4	9.4	9.4

Max. breakout force with ripper bucket

134.6 kN (13.7t)

Operating weight

The operating weight includes the basic machine with 8 tyres, two-piece boom 4.85 m, stick 2.25 m, quick coupler SWA 33 and backhoe bucket 850 mm / 0.50 m³.

Undercarriage versions	Weight (kg)
A 916 Compact Litronic with rear blade	16,100
A 916 Compact Litronic with rear outriggers + front blade	17,200
A 916 Compact EW Litronic with rear blade	16,200
A 916 Compact EW Litronic with rear outriggers + front blade	17,300

Backhoe bucket Machine stability per ISO 10567* (75% of tipping capacity)

Cutting width mm	Capacity ISO 7451 ¹⁾ m ³	Weight kg	Stabilizers raised			Rear blade down			Rear outriggers + front blade down			EW Stabilizers raised			EW Rear blade down			EW Rear outriggers + front blade down		
			Stick length (m)			Stick length (m)			Stick length (m)			Stick length (m)			Stick length (m)			Stick length (m)		
			2.25	2.45	2.65	2.25	2.45	2.65	2.25	2.45	2.65	2.25	2.45	2.65	2.25	2.45	2.65	2.25	2.45	2.65
300 ²⁾	0.17	210	■	■	■	■	■	■	■	■	■	■	■	■	■	■	■	■	■	
400 ²⁾	0.24	240	■	■	■	■	■	■	■	■	■	■	■	■	■	■	■	■	■	
500 ²⁾	0.28	240	■	■	■	■	■	■	■	■	■	■	■	■	■	■	■	■	■	
550 ²⁾	0.29	250	■	■	■	■	■	■	■	■	■	■	■	■	■	■	■	■	■	
650 ²⁾	0.36	270	■	■	■	■	■	■	■	■	■	■	■	■	■	■	■	■	■	
850 ²⁾	0.50	320	■	■	■	■	■	■	■	■	■	■	■	■	■	■	■	■	■	
1,050 ²⁾	0.65	365	■	■	■	■	■	■	■	■	■	■	■	■	■	■	■	■	■	
1,250 ²⁾	0.80	415	■	■	■	■	■	■	■	■	■	■	■	■	■	■	■	■	■	
300 ³⁾	0.18	200	■	■	■	■	■	■	■	■	■	■	■	■	■	■	■	■	■	
400 ³⁾	0.26	230	■	■	■	■	■	■	■	■	■	■	■	■	■	■	■	■	■	
500 ³⁾	0.30	230	■	■	■	■	■	■	■	■	■	■	■	■	■	■	■	■	■	
550 ³⁾	0.31	235	■	■	■	■	■	■	■	■	■	■	■	■	■	■	■	■	■	
650 ³⁾	0.39	260	■	■	■	■	■	■	■	■	■	■	■	■	■	■	■	■	■	
850 ³⁾	0.53	305	■	■	■	■	■	■	■	■	■	■	■	■	■	■	■	■	■	
1,050 ³⁾	0.71	355	■	■	■	■	■	■	■	■	■	■	■	■	■	■	■	■	■	
1,250 ³⁾	0.87	400	■	■	■	■	■	■	■	■	■	■	■	■	■	■	■	■	■	

* indicated loads are based on ISO 10567 and do not exceed 75% of tipping or 87% of hydraulic capacity, max. stick length without quick coupler, lifted 360° on firm with blocked oscillating axle

¹⁾ comparable with SAE (heaped)

²⁾ backhoe bucket with teeth ³⁾ backhoe bucket with cutting edge

Backhoe buckets up to 500 mm cutting width with limited digging depth

Max. material weight ■ = ≤ 1.8t/m³, ■ = ≤ 1.5t/m³, △ = ≤ 1.2t/m³, — = not authorised

Lift capacities

with two-piece boom 4.85 m

Stick 2.25 m

m	Undercarriage stabilized		3.0 m		4.5 m		6.0 m		7.5 m		m
	rear	front									
7.5	-	-							2.4*	2.4*	4.4
	Blade	-							2.4*	2.4*	
	Outriggers	Blade							2.4*	2.4*	
6.0	-	-							2.1*	2.1*	5.9
	Blade	-			4.0	4.2*			2.1*	2.1*	
	Outriggers	Blade			4.2*	4.2*			2.1*	2.1*	
4.5	-	-	5.5*	5.5*	4.0	5.2*	2.5	4.0*	2.0	2.0*	6.8
	Blade	-	5.5*	5.5*	4.4	5.2*	2.8	4.0*	2.0*	2.0*	
	Outriggers	Blade	5.5*	5.5*	5.2*	5.2*	4.0*	4.0*	2.0*	2.0*	
3.0	-	-	6.9	9.1*	3.9	6.1*	2.5	4.0	1.7	2.1*	7.2
	Blade	-	7.7	9.1*	4.3	6.1*	2.7	4.8*	1.9	2.1*	
	Outriggers	Blade	9.1*	9.1*	6.1*	6.1*	4.2	4.8*	2.1*	2.1*	
1.5	-	-	6.8	10.3*	3.9	6.1	2.4	4.0	1.6	2.3*	7.3
	Blade	-	7.5	10.3*	4.2	6.8*	2.7	5.0*	1.8	2.3*	
	Outriggers	Blade	10.3*	10.3*	6.2	6.8*	4.1	5.0*	2.3*	2.3*	
0	-	-	6.7	10.9*	3.7	6.1	2.2	3.8	1.7	2.7*	7.1
	Blade	-	7.5	10.9*	4.1	6.9*	2.5	5.1*	1.9	2.7*	
	Outriggers	Blade	10.9*	10.9*	6.3	6.9*	4.0	5.1*	2.7*	2.7*	
-1.5	-	-	6.3	11.0*	3.4	5.9	2.1	3.7	1.9	3.3	6.5
	Blade	-	7.2	11.0*	3.8	7.1*	2.4	4.7*	2.1	3.5*	
	Outriggers	Blade	11.0*	11.0*	6.2	7.1*	3.8	4.7*	3.4	3.5*	
-3.0	-	-	6.0	10.5*	3.2	5.7			2.4	3.4*	5.5
	Blade	-	6.8	10.5*	3.6	5.8*			2.7	3.4*	
	Outriggers	Blade	10.5*	10.5*	5.8*	5.8*			3.4*	3.4*	

Stick 2.45 m

m	Undercarriage stabilized		3.0 m		4.5 m		6.0 m		7.5 m		m
	rear	front									
7.5	-	-							2.2*	2.2*	4.7
	Blade	-			2.6*	2.6*			2.2*	2.2*	
	Outriggers	Blade			2.6*	2.6*			2.2*	2.2*	
6.0	-	-							3.9*	3.9*	6.1
	Blade	-			3.9*	3.9*	2.3*	2.3*	1.9*	1.9*	
	Outriggers	Blade			3.9*	3.9*	2.3*	2.3*	1.9*	1.9*	
4.5	-	-	6.9	8.7*	3.9	5.9*	2.5	4.0	1.6	1.9*	7.4
	Blade	-	7.7	8.7*	4.3	5.9*	2.8	4.7*	1.9	1.9*	
	Outriggers	Blade	8.7*	8.7*	5.9*	5.9*	4.2	4.7*	1.9*	1.9*	
3.0	-	-	6.8	10.3*	3.8	6.0	2.4	4.0	1.6	2.1*	7.5
	Blade	-	7.5	10.3*	4.2	6.7*	2.7	5.0*	1.8	2.1*	
	Outriggers	Blade	10.3*	10.3*	6.2	6.7*	4.1	5.0*	2.1*	2.1*	
1.5	-	-	6.7	10.8*	3.7	6.1	2.3	3.8	1.6	2.4*	7.3
	Blade	-	7.5	10.8*	4.1	6.9*	2.5	5.0*	1.8	2.4*	
	Outriggers	Blade	10.8*	10.8*	6.2	6.9*	4.0	5.0*	2.4*	2.4*	
0	-	-	6.3	10.9*	3.4	6.0	2.1	3.7	1.7	3.0*	6.7
	Blade	-	7.2	10.9*	3.8	7.0*	2.4	4.9*	2.0	3.0*	
	Outriggers	Blade	10.9*	10.9*	6.2	7.0*	3.8	4.9*	3.0*	3.0*	
-3.0	-	-	6.0	10.9*	3.2	5.7			2.2	3.3*	5.7
	Blade	-	6.8	10.9*	3.6	6.2*			2.5	3.3*	
	Outriggers	Blade	10.9*	10.9*	5.9	6.2*			3.3*	3.3*	

Stick 2.65 m

m	Undercarriage stabilized		3.0 m		4.5 m		6.0 m		7.5 m		m
	rear	front									
7.5	-	-			2.9*	2.9*			2.0*	2.0*	5.0
	Blade	-			2.9*	2.9*			2.0*	2.0*	
	Outriggers	Blade			2.9*	2.9*			2.0*	2.0*	
6.0	-	-			3.7*	3.7*	2.5	2.6*	1.8*	1.8*	6.4
	Blade	-			3.7*	3.7*	2.6*	2.6*	1.8*	1.8*	
	Outriggers	Blade			3.7*	3.7*	2.6*	2.6*	1.8*	1.8*	
4.5	-	-	4.0	4.4*	2.5	3.7*			1.7*	1.7*	7.2
	Blade	-	4.3	4.4*	2.8	3.7*			1.7*	1.7*	
	Outriggers	Blade	4.4*	4.4*	3.7*	3.7*			1.7*	1.7*	
3.0	-	-	6.9	8.3*	3.9	5.7*	2.5	4.1	1.6	2.1*	7.6
	Blade	-	7.7	8.3*	4.3	5.7*	2.8	4.6*	1.8	2.1*	
	Outriggers	Blade	8.3*	8.3*	5.7*	5.7*	4.2	4.6*	2.1*	2.1*	
1.5	-	-	6.7	10.2*	3.8	6.0	2.4	4.0	1.6	2.7*	7.7
	Blade	-	7.5	10.2*	4.2	6.6*	2.7	4.9*	1.7	2.7*	
	Outriggers	Blade	10.2*	10.2*	6.2	6.6*	4.1	4.9*	2.7*	2.7*	
0	-	-	6.7	10.7*	3.7	6.0	2.3	3.9	1.5	2.2*	7.5
	Blade	-	7.5	10.7*	4.1	6.9*	2.5	5.0*	1.7	2.2*	
	Outriggers	Blade	10.7*	10.7*	6.2	6.9*	4.0	5.0*	2.2*	2.2*	
-1.5	-	-	6.3	10.9*	3.4	6.0	2.1	3.7	1.7	2.7*	6.9
	Blade	-	7.2	10.9*	3.9	6.9*	2.4	5.0*	1.9	2.7*	
	Outriggers	Blade	10.9*	10.9*	6.2	6.9*	3.8	5.0*	2.7*	2.7*	
-3.0	-	-	6.0	11.1*	3.2	5.7			2.1	3.3*	6.0
	Blade	-	6.9	11.1*	3.6	6.5*			2.3	3.3*	
	Outriggers	Blade	11.1*	11.1*	5.9	6.5*			3.3*	3.3*	

Height Can be slewed through 360° In longitudinal position of undercarriage Max. reach * Limited by hydr. capacity

The lift capacities with PowerLift function on the load hook of the Liebherr quick coupler SWA 33 without attachment are stated in metric tons (t) and are valid on a firm, level supporting surface with blocked oscillating axle. These capacities can be slewed through 360° with the undercarriage in the transverse position. Capacities in the longitudinal position of the undercarriage (±15°) are specified over the steering axle with the stabilizers raised and over the rigid axle with the stabilizers down. The values apply when the adjusting cylinder is in the optimal position. Indicated loads based on the ISO 10567 standard and do not exceed 75% of tipping or 87% of hydraulic capacity, or are limited by the permissible load of the load hook on the quick coupler (max. 5t). Without the quick coupler, lift capacities will increase by up to 110 kg.

In accordance with the harmonised European Standard EN 474-5, hydraulic excavators used for lifting operations must be equipped with pipe fracture safety valves, an overload warning device, a load hook and a lift capacity chart.

Lift capacities

with two-piece boom 4.85 m, EW undercarriage

Stick 2.25 m

m	Undercarriage stabilized		3.0 m		4.5 m		6.0 m		7.5 m		m
	rear	front									
7.5	-	-									2.4* 2.4*
6.0	Blade	-									2.4* 2.4*
	Outriggers	Blade									2.4* 2.4*
4.5	Blade	-			4.2* 4.2*						2.1* 2.1*
	Outriggers	Blade			4.2* 4.2*						2.1* 2.1*
3.0	Blade	-	5.5* 5.5*	4.3 5.2*	2.7 4.0*						2.0* 2.0*
	Outriggers	Blade	5.5* 5.5*	5.2* 5.2*	4.0* 4.0*						2.0* 2.0*
1.5	Blade	-	7.6 9.1*	4.3 6.1*	2.7 4.1						1.9 2.1*
	Outriggers	Blade	9.1* 9.1*	6.1* 6.1*	4.4 4.8*						2.1* 2.1*
0	Blade	-	7.5 10.3*	4.2 6.1	2.6 4.0						1.8 2.3*
	Outriggers	Blade	10.3* 10.3*	6.5 6.8*	4.3 5.0*						2.3* 2.3*
-1.5	Blade	-	7.5 10.9*	4.1 6.1	2.5 3.8						1.9 2.7*
	Outriggers	Blade	10.9* 10.9*	6.5 6.9*	4.2 5.1*						2.7* 2.7*
-3.0	Blade	-	7.1 11.0*	3.8 6.0	2.4 3.7						2.1 3.3
	Outriggers	Blade	11.0* 11.0*	6.5 7.1*	4.1 4.7*						2.3 3.5*
-3.0	Blade	-	6.8 10.5*	3.6 5.7							2.7 3.4*
	Outriggers	Blade	10.5* 10.5*	5.8* 5.8*							3.4* 3.4*

Stick 2.45 m

m	Undercarriage stabilized		3.0 m		4.5 m		6.0 m		7.5 m		m
	rear	front									
7.5	-	-									2.2* 2.2*
7.5	Blade	-									2.2* 2.2*
	Outriggers	Blade									2.2* 2.2*
6.0	Blade	-									1.9* 1.9*
	Outriggers	Blade									1.9* 1.9*
4.5	Blade	-									1.9* 1.9*
	Outriggers	Blade									1.9* 1.9*
3.0	Blade	-	7.6 8.7*	4.2 5.9*	2.7 4.1						1.8 1.9*
	Outriggers	Blade	8.7* 8.7*	5.9* 5.9*	4.4 4.7*						1.9* 1.9*
1.5	Blade	-	7.4 10.3*	4.2 6.0	2.6 4.0						1.7 2.1*
	Outriggers	Blade	10.3* 10.3*	6.5 6.7*	4.3 5.0*						2.1* 2.1*
0	Blade	-	7.5 10.8*	4.1 6.1	2.5 3.9						1.8 2.4*
	Outriggers	Blade	10.8* 10.8*	6.5 6.9*	4.2 5.0*						2.4* 2.4*
-1.5	Blade	-	7.1 10.9*	3.8 6.0	2.4 3.7						2.0 3.0*
	Outriggers	Blade	10.9* 10.9*	6.5 7.0*	4.0 4.9*						2.2 3.0*
-3.0	Blade	-	6.8 10.9*	3.6 5.7							2.5 3.3*
	Outriggers	Blade	10.9* 10.9*	6.2* 6.2*							3.3* 3.3*

Stick 2.65 m

m	Undercarriage stabilized		3.0 m		4.5 m		6.0 m		7.5 m		m
	rear	front									
7.5	-	-									2.0* 2.0*
6.0	Blade	-									2.0* 2.0*
	Outriggers	Blade									2.0* 2.0*
4.5	Blade	-									1.8* 1.8*
	Outriggers	Blade									1.8* 1.8*
3.0	Blade	-									1.7* 1.7*
	Outriggers	Blade									1.7* 1.7*
1.5	Blade	-									1.7* 1.7*
	Outriggers	Blade									1.7* 1.7*
0	Blade	-									1.7* 1.7*
	Outriggers	Blade									1.7* 1.7*
-1.5	Blade	-									1.7* 1.7*
	Outriggers	Blade									1.7* 1.7*
-3.0	Blade	-									1.7* 1.7*
	Outriggers	Blade									1.7* 1.7*

Height Can be slewed through 360° In longitudinal position of undercarriage Max. reach * Limited by hydr. capacity

The lift capacities with PowerLift function on the load hook of the Liebherr quick coupler SWA 33 without attachment are stated in metric tons (t) and are valid on a firm, level supporting surface with blocked oscillating axle. These capacities can be slewed through 360° with the undercarriage in the transverse position. Capacities in the longitudinal position of the undercarriage (±15°) are specified over the steering axle with the stabilizers raised and over the rigid axle with the stabilizers down. The values apply when the adjusting cylinder is in the optimal position. Indicated loads based on the ISO 10567 standard and do not exceed 75% of tipping or 87% of hydraulic capacity, or are limited by the permissible load of the load hook on the quick coupler (max. 5t). Without the quick coupler, lift capacities will increase by up to 110 kg.

In accordance with the harmonised European Standard EN 474-5, hydraulic excavators used for lifting operations must be equipped with pipe fracture safety valves, an overload warning device, a load hook and a lift capacity chart.

Backhoe bucket

with offset two-piece boom 4.90 m

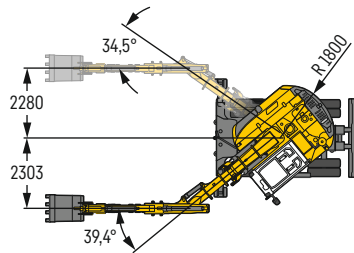
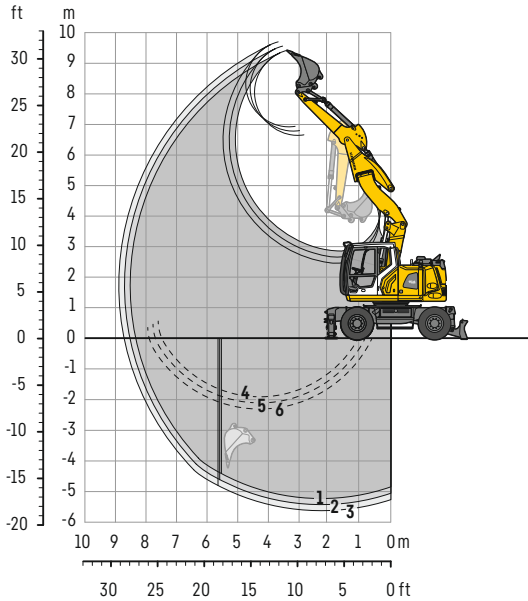

Digging envelope

with quick coupler	1	2	3
Stick length	m 2.25	2.45	2.65
Max. digging depth	m 5.25	5.45	5.65
Max. reach at ground level	m 8.35	8.55	8.75
Max. dumping height	m 6.65	6.80	6.95
Max. teeth height	m 9.40	9.55	9.70
Min. equipment radius	m 2.15	2.18	2.20

1 with stick 2.25 m
2 with stick 2.45 m
3 with stick 2.65 m
with set straight boom

4 with stick 2.25 m
5 with stick 2.45 m
6 with stick 2.65 m
at max. equipment offset with vertical ditch walls

Digging forces

without quick coupler with PowerLift function	1	2	3
Max. digging force (ISO 6015)	kN 74.7	70.0	65.9
	t 7.6	7.1	6.7
Max. breakout force (ISO 6015)	kN 92.4	92.4	92.4
	t 9.4	9.4	9.4

Max. breakout force with ripper bucket 134.6 kN (13.7t)

Operating weight

The operating weight includes the basic machine with 8 tyres, offset two-piece boom 4.90 m, stick 2.25 m, quick coupler SWA 33 and backhoe bucket 850 mm / 0.50 m³.

Undercarriage versions	Weight (kg)
A 916 Compact Litronic with rear blade	16,600
A 916 Compact Litronic with rear outriggers + front blade	17,600
A 916 Compact EW Litronic with rear blade	16,600
A 916 Compact EW Litronic with rear outriggers + front blade	17,700

Backhoe bucket Machine stability per ISO 10567* (75% of tipping capacity)

Cutting width mm	Capacity ISO 7451 ¹⁾ m ³	Weight kg	Stabilizers raised		Rear blade down			Rear outriggers + front blade down			EW Stabilizers raised			EW Rear blade down			EW Rear outriggers + front blade down			
			Stick length (m)			Stick length (m)			Stick length (m)			Stick length (m)			Stick length (m)			Stick length (m)		
			2.25	2.45	2.65	2.25	2.45	2.65	2.25	2.45	2.65	2.25	2.45	2.65	2.25	2.45	2.65	2.25	2.45	2.65
300 ²⁾	0.17	210	■	■	■	■	■	■	■	■	■	■	■	■	■	■	■	■	■	
400 ²⁾	0.24	240	■	■	■	■	■	■	■	■	■	■	■	■	■	■	■	■	■	
500 ²⁾	0.28	240	■	■	■	■	■	■	■	■	■	■	■	■	■	■	■	■	■	
550 ²⁾	0.29	250	■	■	■	■	■	■	■	■	■	■	■	■	■	■	■	■	■	
650 ²⁾	0.36	270	■	■	■	■	■	■	■	■	■	■	■	■	■	■	■	■	■	
850 ²⁾	0.50	320	■	■	■	■	■	■	■	■	■	■	■	■	■	■	■	■	■	
1,050 ²⁾	0.65	365	■	■	■	■	■	■	■	■	■	■	■	■	■	■	■	■	■	
1,250 ²⁾	0.80	415	■	■	△	■	■	■	■	■	■	■	■	■	■	■	■	■	■	
300 ³⁾	0.18	200	■	■	■	■	■	■	■	■	■	■	■	■	■	■	■	■	■	
400 ³⁾	0.26	230	■	■	■	■	■	■	■	■	■	■	■	■	■	■	■	■	■	
500 ³⁾	0.30	230	■	■	■	■	■	■	■	■	■	■	■	■	■	■	■	■	■	
550 ³⁾	0.31	235	■	■	■	■	■	■	■	■	■	■	■	■	■	■	■	■	■	
650 ³⁾	0.39	260	■	■	■	■	■	■	■	■	■	■	■	■	■	■	■	■	■	
850 ³⁾	0.53	305	■	■	■	■	■	■	■	■	■	■	■	■	■	■	■	■	■	
1,050 ³⁾	0.71	355	■	■	■	■	■	■	■	■	■	■	■	■	■	■	■	■	■	
1,250 ³⁾	0.87	400	■	△	△	■	■	■	■	■	■	■	■	■	■	■	■	■	■	

* indicated loads are based on ISO 10567 and do not exceed 75% of tipping or 87% of hydraulic capacity, max. stick length without quick coupler, lifted 360° on firm with blocked oscillating axle

¹⁾ comparable with SAE (heaped)

²⁾ backhoe bucket with teeth ³⁾ backhoe bucket with cutting edge

Backhoe buckets up to 500 mm cutting width with limited digging depth

Max. material weight ■ = ≤ 1.8t/m³, ■ = ≤ 1.5t/m³, △ = ≤ 1.2t/m³, — = not authorised

Lift capacities

with offset two-piece boom 4.90 m

Stick 2.25 m

m	Undercarriage stabilized		3.0 m		4.5 m		6.0 m		7.5 m		m
	rear	front									
7.5	-	-							2.3*	2.3*	4.3
	Blade	-							2.3*	2.3*	
	Outriggers	Blade							2.3*	2.3*	
6.0	-	-			4.0	4.1*			2.0*	2.0*	5.9
	Blade	-			4.1*	4.1*			2.0*	2.0*	
	Outriggers	Blade			4.1*	4.1*			2.0*	2.0*	
4.5	-	-			3.9	4.9*	2.4	3.9*	1.9	2.0*	6.7
	Blade	-			4.3	4.9*	2.7	3.9*	2.0*	2.0*	
	Outriggers	Blade			4.9*	4.9*	3.9*	3.9*	2.0*	2.0*	
3.0	-	-	6.8	8.7*	3.8	5.7*	2.4	4.0	1.6	2.1*	7.2
	Blade	-	7.5	8.7*	4.2	5.7*	2.7	4.5*	1.8	2.1*	
	Outriggers	Blade	8.7*	8.7*	5.7*	5.7*	4.1	4.5*	2.1*	2.1*	
1.5	-	-	6.6	9.9*	3.8	5.9	2.3	3.9	1.5	2.3*	7.3
	Blade	-	7.3*	9.9*	4.2	6.4*	2.6	4.8*	1.7	2.3*	
	Outriggers	Blade	9.9*	9.9*	6.0	6.4*	4.0	4.8*	2.3*	2.3*	
0	-	-	6.6	10.4*	3.6	5.9	2.1	3.7	1.5	2.7*	7.0
	Blade	-	7.4	10.4*	4.1	6.6*	2.4	4.9*	1.7	2.7*	
	Outriggers	Blade	10.4*	10.4*	6.1	6.6*	3.9	4.9*	2.7*	2.7*	
-1.5	-	-	6.2	10.6*	3.2	5.8	1.9	3.6	1.7	3.1	6.5
	Blade	-	7.0	10.6*	3.6	6.8*	2.2	4.6*	1.9	3.6*	
	Outriggers	Blade	10.6*	10.6*	6.0	6.8*	3.7	4.6*	3.3	3.6*	
-3.0	-	-	5.7	10.3*	3.0	5.5			2.2	3.5*	5.4
	Blade	-	6.6	10.3*	3.4	5.7*			2.5	3.5*	
	Outriggers	Blade	10.3*	10.3*	5.7*	5.7*			3.5*	3.5*	

Stick 2.45 m

m	Undercarriage stabilized		3.0 m		4.5 m		6.0 m		7.5 m		m
	rear	front									
7.5	-	-							2.1*	2.1*	4.6
	Blade	-			2.4*	2.4*			2.1*	2.1*	
	Outriggers	Blade			2.4*	2.4*			2.1*	2.1*	
6.0	-	-			3.9*	3.9*	2.1*	2.1*	1.8*	1.8*	6.1
	Blade	-			3.9*	3.9*	2.1*	2.1*	1.8*	1.8*	
	Outriggers	Blade			3.9*	3.9*	2.1*	2.1*	1.8*	1.8*	
4.5	-	-			3.9	4.7*	2.5	3.8*	1.8	1.8*	6.9
	Blade	-			4.3	4.7*	2.7	3.8*	1.8*	1.8*	
	Outriggers	Blade			4.7*	4.7*	3.8*	3.8*	1.8*	1.8*	
3.0	-	-	6.8	8.3*	3.8	5.6*	2.4	4.0	1.5	1.9*	7.3
	Blade	-	7.5	8.3*	4.2	5.6*	2.7	4.4*	1.8	1.9*	
	Outriggers	Blade	8.3*	8.3*	5.6*	5.6*	4.1	4.4*	1.9*	1.9*	
1.5	-	-	6.6	9.8*	3.8	5.9	2.3	3.9	1.4	2.1*	7.5
	Blade	-	7.3	9.8*	4.1	6.3*	2.6	4.7*	1.6	2.1*	
	Outriggers	Blade	9.8*	9.8*	6.0	6.3*	4.0	4.7*	2.1*	2.1*	
0	-	-	6.6	10.3*	3.6	5.9	2.1	3.7	1.4	2.4*	7.2
	Blade	-	7.3	10.3*	4.1	6.6*	2.4	4.8*	1.7	2.4*	
	Outriggers	Blade	10.3*	10.3*	6.0	6.6*	3.9	4.8*	2.4*	2.4*	
-1.5	-	-	6.2	10.5*	3.3	5.9	1.9	3.6	1.6	3.0	6.7
	Blade	-	7.0	10.5*	3.7	6.7*	2.2	4.7*	1.8	3.1*	
	Outriggers	Blade	10.5*	10.5*	6.1	6.7*	3.7	4.7*	3.1	3.1*	
-3.0	-	-	5.7	10.6*	3.0	5.5			2.0	3.5*	5.7
	Blade	-	6.6	10.6*	3.4	6.1*			2.3	3.5*	
	Outriggers	Blade	10.6*	10.6*	5.7	6.1*			3.5*	3.5*	

Stick 2.65 m

m	Undercarriage stabilized		3.0 m		4.5 m		6.0 m		7.5 m		m
	rear	front									
7.5	-	-			2.7*	2.7*			1.9*	1.9*	4.9
	Blade	-			2.7*	2.7*			1.9*	1.9*	
	Outriggers	Blade			2.7*	2.7*			1.9*	1.9*	
6.0	-	-			3.6*	3.6*	2.4*	2.4*	1.7*	1.7*	6.3
	Blade	-			3.6*	3.6*	2.4*	2.4*	1.7*	1.7*	
	Outriggers	Blade			3.6*	3.6*	2.4*	2.4*	1.7*	1.7*	
4.5	-	-			4.0	4.5*	2.5	3.7*	1.7*	1.7*	7.1
	Blade	-			4.3	4.5*	2.8	3.7*	1.7*	1.7*	
	Outriggers	Blade			4.5*	4.5*	3.7*	3.7*	1.7*	1.7*	
3.0	-	-	6.8	7.9*	3.8	5.4*	2.5	4.0	1.5	1.9*	7.5
	Blade	-	7.5	7.9*	4.2	5.4*	2.7	4.3*	1.7	1.9*	
	Outriggers	Blade	7.9*	7.9*	5.4*	5.4*	4.1	4.3*	1.9*	1.9*	
1.5	-	-	6.6	9.8*	3.7	5.8	2.4	3.9	1.4	2.5*	7.6
	Blade	-	7.3	9.8*	4.1	6.2*	2.6	4.6*	1.6	2.5*	
	Outriggers	Blade	9.8*	9.8*	6.0	6.2*	4.0	4.6*	2.5*	2.5*	
0	-	-	6.6	10.2*	3.7	5.9	2.2	3.8	1.4	2.2*	7.4
	Blade	-	7.3	10.2*	4.1	6.5*	2.4	4.8*	1.6	2.2*	
	Outriggers	Blade	10.2*	10.2*	6.0	6.5*	3.9	4.8*	2.2*	2.2*	
-1.5	-	-	6.2	10.4*	3.3	5.9	2.0	3.6	1.5	2.8*	6.9
	Blade	-	7.1	10.4*	3.7	6.6*	2.2	4.8*	1.7	2.8*	
	Outriggers	Blade	10.4*	10.4*	6.1	6.6*	3.7	4.8*	2.8*	2.8*	
-3.0	-	-	5.8	10.8*	3.0	5.5			1.9	3.4*	5.9
	Blade	-	6.6	10.8*	3.4	6.4*			2.2	3.4*	
	Outriggers	Blade	10.8*	10.8*	5.7	6.4*			3.4*	3.4*	
-4.5	-	-							8.1*	8.1*	2.3
	Blade	-							8.1*	8.1*	
	Outriggers	Blade							8.1*	8.1*	

Height Can be slewed through 360° In longitudinal position of undercarriage Max. reach * Limited by hydr. capacity

The lift capacities with PowerLift function on the load hook of the Liebherr quick coupler SWA 33 without attachment are stated in metric tons (t) and are valid on a firm, level supporting surface with blocked oscillating axle. These capacities can be slewed through 360° with the undercarriage in the transverse position. Capacities in the longitudinal position of the undercarriage (±15°) are specified over the steering axle with the stabilizers raised and over the rigid axle with the stabilizers down. The values apply when the adjusting cylinder is in the optimal position. Indicated loads based on the ISO 10567 standard and do not exceed 75% of tipping or 87% of hydraulic capacity, or are limited by the permissible load of the load hook on the quick coupler (max. 5t). Without the quick coupler, lift capacities will increase by up to 110 kg.

In accordance with the harmonised European Standard EN 474-5, hydraulic excavators used for lifting operations must be equipped with pipe fracture safety valves, an overload warning device, a load hook and a lift capacity chart.

Lift capacities

with offset two-piece boom 4.90 m, EW undercarriage

Stick 2,25 m

m	Undercarriage stabilized		3.0 m		4.5 m		6.0 m		7.5 m		m
	rear	front									
7.5	-	-							2.3*	2.3*	4.3
	Blade	-							2.3*	2.3*	
	Outriggers	Blade							2.3*	2.3*	
6.0	-	-			4.1*	4.1*			2.0*	2.0*	5.9
	Blade	-			4.1*	4.1*			2.0*	2.0*	
	Outriggers	Blade			4.1*	4.1*			2.0*	2.0*	
4.5	-	-			4.3	4.9*	2.7	3.9*	2.0*	2.0*	6.7
	Blade	-			4.7	4.9*	3.0	3.9*	2.0*	2.0*	
	Outriggers	Blade			4.9*	4.9*	3.9*	3.9*	2.0*	2.0*	
3.0	-	-	7.5	8.7*	4.2	5.7*	2.6	4.0	1.8	2.1*	7.2
	Blade	-	8.3	8.7*	4.6	5.7*	2.9	4.5*	2.1	2.1*	
	Outriggers	Blade	8.7*	8.7*	5.7*	5.7*	4.3	4.5*	2.1*	2.1*	
1.5	-	-	7.3	9.9*	4.1	5.9	2.5	3.9	1.7	2.3*	7.3
	Blade	-	8.1	9.9*	4.5	6.4*	2.8	4.8*	1.9	2.3*	
	Outriggers	Blade	9.9*	9.9*	6.3	6.4*	4.2	4.8*	2.3*	2.3*	
0	-	-	7.4	10.4*	4.0	6.0	2.4	3.7	1.7	2.7*	7.0
	Blade	-	8.2	10.4*	4.5	6.6*	2.7	4.9*	2.0	2.7*	
	Outriggers	Blade	10.4*	10.4*	6.3	6.6*	4.1	4.9*	2.7*	2.7*	
-1.5	-	-	7.0	10.6*	3.6	5.8	2.2	3.6	1.9	3.2	6.5
	Blade	-	8.0	10.6*	4.1	6.8*	2.5	4.6*	2.2	3.6*	
	Outriggers	Blade	10.6*	10.6*	6.4	6.8*	3.9	4.6*	3.4	3.6*	
-3.0	-	-	6.5	10.3*	3.3	5.5			2.5	3.5*	5.4
	Blade	-	7.5	10.3*	3.8	5.7*			2.9	3.5*	
	Outriggers	Blade	10.3*	10.3*	5.7*	5.7*			3.5*	3.5*	

Stick 2.45 m

m	Undercarriage stabilized		3.0 m		4.5 m		6.0 m		7.5 m		m
	rear	front									
7.5	-	-							2.1*	2.1*	4.6
	Blade	-			2.4*	2.4*			2.1*	2.1*	
	Outriggers	Blade			2.4*	2.4*			2.1*	2.1*	
6.0	-	-			3.9*	3.9*	2.1*	2.1*	1.8*	1.8*	6.1
	Blade	-			3.9*	3.9*	2.1*	2.1*	1.8*	1.8*	
	Outriggers	Blade			3.9*	3.9*	2.1*	2.1*	1.8*	1.8*	
4.5	-	-			4.3	4.7*	2.7	3.8*	1.8*	1.8*	6.9
	Blade	-			4.7	4.7*	3.0	3.8*	1.8*	1.8*	
	Outriggers	Blade			4.7*	4.7*	3.8*	3.8*	1.8*	1.8*	
3.0	-	-	7.5	8.3*	4.2	5.6*	2.7	4.0	1.7	1.9*	7.3
	Blade	-	8.3	8.3*	4.6	5.6*	3.0	4.4*	1.9*	1.9*	
	Outriggers	Blade	8.3*	8.3*	5.6*	5.6*	4.2	4.4*	1.9*	1.9*	
1.5	-	-	7.2	9.8*	4.1	5.9	2.6	3.9	1.6	2.1*	7.5
	Blade	-	8.0	9.8*	4.5	6.3*	2.9	4.7*	1.8	2.1*	
	Outriggers	Blade	9.8*	9.8*	6.3	6.3*	4.2	4.7*	2.1*	2.1*	
0	-	-	7.3	10.3*	4.0	5.9	2.4	3.7	1.6	2.4*	7.2
	Blade	-	8.1	10.3*	4.5	6.6*	2.7	4.8*	1.9	2.4*	
	Outriggers	Blade	10.3*	10.3*	6.3	6.6*	4.1	4.8*	2.4*	2.4*	
-1.5	-	-	7.0	10.5*	3.6	5.9	2.2	3.6	1.8	3.0	6.7
	Blade	-	8.0	10.5*	4.1	6.7*	2.5	4.7*	2.1	3.1*	
	Outriggers	Blade	10.5*	10.5*	6.4	6.7*	3.9	4.7*	3.1*	3.1*	
-3.0	-	-	6.5	10.6*	3.3	5.5			2.3	3.5*	5.7
	Blade	-	7.5	10.6*	3.8	6.1*			2.6	3.5*	
	Outriggers	Blade	10.6*	10.6*	6.1	6.1*			3.5*	3.5*	

Stick 2.65 m

m	Undercarriage stabilized		3.0 m		4.5 m		6.0 m		7.5 m		m
	rear	front									
7.5	-	-			2.7*	2.7*			1.9*	1.9*	4.9
	Blade	-			2.7*	2.7*			1.9*	1.9*	
	Outriggers	Blade			2.7*	2.7*			1.9*	1.9*	
6.0	-	-			3.6*	3.6*	2.4*	2.4*	1.7*	1.7*	6.3
	Blade	-			3.6*	3.6*	2.4*	2.4*	1.7*	1.7*	
	Outriggers	Blade			3.6*	3.6*	2.4*	2.4*	1.7*	1.7*	
4.5	-	-			4.3	4.5*	2.7	3.7*	1.7*	1.7*	7.1
	Blade	-			4.5*	4.5*	3.0	3.7*	1.7*	1.7*	
	Outriggers	Blade			4.5*	4.5*	3.7*	3.7*	1.7*	1.7*	
3.0	-	-	7.5	7.9*	4.2	5.4*	2.7	4.0	1.7	1.7*	7.5
	Blade	-	7.9*	7.9*	4.6	5.4*	3.0	4.3*	1.9*	1.9*	
	Outriggers	Blade	7.9*	7.9*	5.4*	5.4*	4.2	4.3*	1.9*	1.9*	
1.5	-	-	7.2	9.8*	4.1	5.9	2.6	3.9	1.6	2.5*	7.6
	Blade	-	8.0	9.8*	4.5	6.2*	2.9	4.6*	1.8	2.5*	
	Outriggers	Blade	9.8*	9.8*	6.2*	6.2*	4.2	4.6*	2.5*	2.5*	
0	-	-	7.3	10.2*	4.1	5.9	2.4	3.8	1.6	2.2*	7.4
	Blade	-	8.0	10.2*	4.5	6.5*	2.7	4.8*	1.8	2.2*	
	Outriggers	Blade	10.2*	10.2*	6.2	6.5*	4.1	4.8*	2.2*	2.2*	
-1.5	-	-	7.0	10.4*	3.7	5.9	2.2	3.6	1.7	2.8*	6.9
	Blade	-	8.0	10.4*	4.2	6.6*	2.5	4.8*	2.0	2.8*	
	Outriggers	Blade	10.4*	10.4*	6.4	6.6*	3.9	4.8*	2.8*	2.8*	
-3.0	-	-	6.6	10.8*	3.4	5.6			2.1	3.4*	5.9
	Blade	-	7.6	10.8*	3.8	6.4*			2.5	3.4*	
	Outriggers	Blade	10.8*	10.8*	6.1	6.4*			3.4*	3.4*	
-4.5	-	-							8.1*	8.1*	2.3
	Blade	-							8.1*	8.1*	
	Outriggers	Blade							8.1*	8.1*	

Height Can be slewed through 360° In longitudinal position of undercarriage Max. reach * Limited by hydr. capacity

The lift capacities with PowerLift function on the load hook of the Liebherr quick coupler SWA 33 without attachment are stated in metric tons (t) and are valid on a firm, level supporting surface with blocked oscillating axle. These capacities can be slewed through 360° with the undercarriage in the transverse position. Capacities in the longitudinal position of the undercarriage (±15°) are specified over the steering axle with the stabilizers raised and over the rigid axle with the stabilizers down. The values apply when the adjusting cylinder is in the optimal position. Indicated loads based on the ISO 10567 standard and do not exceed 75% of tipping or 87% of hydraulic capacity, or are limited by the permissible load of the load hook on the quick coupler (max. 5t). Without the quick coupler, lift capacities will increase by up to 110 kg.

In accordance with the harmonised European Standard EN 474-5, hydraulic excavators used for lifting operations must be equipped with pipe fracture safety valves, an overload warning device, a load hook and a lift capacity chart.

Equipments

Clamshell grab

Clamshell grab GMZ 18 Machine stability per ISO 10567* (75% of tipping capacity)

Cutting width mm	Capacity ISO 7451 ¹⁾ m ³	Weight kg	Stabilizers raised			Rear blade down			Rear outriggers + front blade down			EW Stabilizers raised			EW Rear blade down			EW Rear outriggers + front blade down		
			Stick length (m)			Stick length (m)			Stick length (m)			Stick length (m)			Stick length (m)			Stick length (m)		
			2.25	2.45	2.65	2.25	2.45	2.65	2.25	2.45	2.65	2.25	2.45	2.65	2.25	2.45	2.65	2.25	2.45	2.65
Two-piece boom 4.85 m																				
320 ¹⁾	0.17	770	■	■	■	■	■	■	■	■	■	■	■	■	■	■	■	■	■	
400 ¹⁾	0.22	800	■	■	■	■	■	■	■	■	■	■	■	■	■	■	■	■	■	
600 ¹⁾	0.30	810	■	■	■	■	■	■	■	■	■	■	■	■	■	■	■	■	■	
800 ¹⁾	0.40	860	■	■	■	■	■	■	■	■	■	■	■	■	■	■	■	■	■	
320 ²⁾	0.17	820	■	■	■	■	■	■	■	■	■	■	■	■	■	■	■	■	■	
400 ²⁾	0.22	855	■	■	■	■	■	■	■	■	■	■	■	■	■	■	■	■	■	
600 ²⁾	0.30	900	■	■	■	■	■	■	■	■	■	■	■	■	■	■	■	■	■	
800 ²⁾	0.40	970	■	■	■	■	■	■	■	■	■	■	■	■	■	■	■	■	■	
Offset two-piece boom 4.90 m																				
320 ¹⁾	0.17	770	■	■	■	■	■	■	■	■	■	■	■	■	■	■	■	■	■	
400 ¹⁾	0.22	800	■	■	■	■	■	■	■	■	■	■	■	■	■	■	■	■	■	
600 ¹⁾	0.30	810	■	■	■	■	■	■	■	■	■	■	■	■	■	■	■	■	■	
800 ¹⁾	0.40	860	■	■	■	■	■	■	■	■	■	■	■	■	■	■	■	■	■	
320 ²⁾	0.17	820	■	■	■	■	■	■	■	■	■	■	■	■	■	■	■	■	■	
400 ²⁾	0.22	855	■	■	■	■	■	■	■	■	■	■	■	■	■	■	■	■	■	
600 ²⁾	0.30	900	■	■	■	■	■	■	■	■	■	■	■	■	■	■	■	■	■	
800 ²⁾	0.40	970	■	■	■	■	■	■	■	■	■	■	■	■	■	■	■	■	■	

* indicated loads are based on ISO 10567 and do not exceed 75% of tipping or 87% of hydraulic capacity, max. stick length without quick coupler, lifted 360° on firm with blocked oscillating axle

¹⁾ without ejector

²⁾ with ejector

Max. material weight ■ = ≤ 1.8t/m³, ■ = ≤ 1.5t/m³, △ = ≤ 1.2t/m³, — = not authorised

Equipments

Ditch cleaning bucket / tilt bucket

Ditch cleaning bucket Machine stability per ISO 10567* (75% of tipping capacity)

Cutting width mm	Capacity ISO 7451 ¹⁾ m ³	Weight kg	Stabilizers raised			Rear blade down			Rear outriggers + front blade down			EW Stabilizers raised			EW Rear blade down			EW Rear outriggers + front blade down		
			Stick length (m)			Stick length (m)			Stick length (m)			Stick length (m)			Stick length (m)			Stick length (m)		
			2.25	2.45	2.65	2.25	2.45	2.65	2.25	2.45	2.65	2.25	2.45	2.65	2.25	2.45	2.65	2.25	2.45	2.65
Two-piece boom 4.85 m																				
1,500 ³⁾	0.35	275	■	■	■	■	■	■	■	■	■	■	■	■	■	■	■	■	■	
1,600 ²⁾	0.55	650	■	■	■	■	■	■	■	■	■	■	■	■	■	■	■	■	■	
1,600 ⁴⁾	0.55	690	■	■	■	■	■	■	■	■	■	■	■	■	■	■	■	■	■	
1,800 ⁴⁾	0.65	720	■	■	■	■	■	■	■	■	■	■	■	■	■	■	■	■	■	
2,000 ⁴⁾	0.70	755	■	■	■	■	■	■	■	■	■	■	■	■	■	■	■	■	■	
2,000 ²⁾	0.50	685	■	■	■	■	■	■	■	■	■	■	■	■	■	■	■	■	■	
2,000 ³⁾	0.48	350	■	■	■	■	■	■	■	■	■	■	■	■	■	■	■	■	■	
2,000 ³⁾	0.65	390	■	■	■	■	■	■	■	■	■	■	■	■	■	■	■	■	■	
Offset two-piece boom 4.90 m																				
1,500 ³⁾	0.35	275	■	■	■	■	■	■	■	■	■	■	■	■	■	■	■	■	■	
1,600 ²⁾	0.55	650	■	■	■	■	■	■	■	■	■	■	■	■	■	■	■	■	■	
1,600 ⁴⁾	0.55	690	■	■	■	■	■	■	■	■	■	■	■	■	■	■	■	■	■	
1,800 ⁴⁾	0.65	720	■	■	■	■	■	■	■	■	■	■	■	■	■	■	■	■	■	
2,000 ⁴⁾	0.70	755	■	△	△	■	■	■	■	■	■	■	■	■	■	■	■	■	■	
2,000 ²⁾	0.50	685	■	■	■	■	■	■	■	■	■	■	■	■	■	■	■	■	■	
2,000 ³⁾	0.48	350	■	■	■	■	■	■	■	■	■	■	■	■	■	■	■	■	■	
2,000 ³⁾	0.65	390	■	■	■	■	■	■	■	■	■	■	■	■	■	■	■	■	■	

* indicated loads are based on ISO 10567 and do not exceed 75% of tipping or 87% of hydraulic capacity, max. stick length without quick coupler, lifted 360° on firm with blocked oscillating axle

¹⁾ comparable with SAE (heaped)

²⁾ ditch cleaning bucket with hydraulic cylinder (with 2 x 50° rotator)

³⁾ rigid ditch cleaning bucket

⁴⁾ ditch cleaning bucket with rotary motor (with 2 x 50° rotator)

Max. material weight ■ = ≤ 1.8t/m³, ■ = ≤ 1.5t/m³, △ = ≤ 1.2t/m³, — = not authorised

Tilt bucket Machine stability per ISO 10567* (75% of tipping capacity)

Cutting width mm	Capacity ISO 7451 ¹⁾ m ³	Weight kg	Stabilizers raised			Rear blade down			Rear outriggers + front blade down			EW Stabilizers raised			EW Rear blade down			EW Rear outriggers + front blade down		
			Stick length (m)			Stick length (m)			Stick length (m)			Stick length (m)			Stick length (m)			Stick length (m)		
			2.25	2.45	2.65	2.25	2.45	2.65	2.25	2.45	2.65	2.25	2.45	2.65	2.25	2.45	2.65	2.25	2.45	2.65
Two-piece boom 4.85 m																				
1,500 ²⁾	0.60	650	■	■	■	■	■	■	■	■	■	■	■	■	■	■	■	■	■	
Offset two-piece boom 4.90 m																				
1,500 ²⁾	0.60	650	■	■	■	■	■	■	■	■	■	■	■	■	■	■	■	■	■	

* indicated loads are based on ISO 10567 and do not exceed 75% of tipping or 87% of hydraulic capacity, max. stick length without quick coupler, lifted 360° on firm with blocked oscillating axle

¹⁾ comparable with SAE (heaped)

²⁾ tilt bucket with hydraulic cylinder (with 2 x 50° rotator)

Max. material weight ■ = ≤ 1.8t/m³, ■ = ≤ 1.5t/m³, △ = ≤ 1.2t/m³, — = not authorised

Attachments

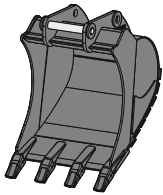

Backhoe bucket TL 02

Mounting		direct mounting, SWA 33 mechanical, SWA 33 hydraulic, SWA 33 Solidlink, SWA 48 mechanical, SWA 48 hydraulic, SWA 48 Solidlink								
Cutting width	mm	300 ³⁾⁴⁾	400 ³⁾⁴⁾	500 ⁴⁾	550	650	850	1,050	1,250	
Capacity	m ³	0.17 ⁵⁾	0.24 ⁵⁾	0.32 ⁵⁾	0.29	0.36	0.50	0.65	0.80	
Weight ¹⁾	kg	225	245	250	260	285	335	380	430	

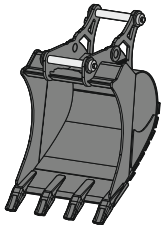

2in1 bucket HTL 02

Mounting		SWA 33 mechanical, SWA 33 hydraulic, SWA 33 Solidlink, SWA 48 mechanical, SWA 48 hydraulic, SWA 48 Solidlink								
Cutting width	mm	300 ³⁾	400 ³⁾	500 ⁴⁾	650	850	1,050	1,250		
Capacity	m ³	0.17	0.24	0.32	0.36	0.50	0.65	0.80		
Weight ¹⁾	kg	284	291	287	321	371	416	465		

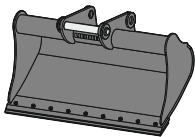

Universal bucket

Mounting		SWA 33 mechanical, SWA 33 hydraulic, SWA 33 Solidlink, SWA 48 mechanical, SWA 48 hydraulic, SWA 48 Solidlink								
UL 02										
Cutting width	mm	1,400				1,400				
Capacity	m ³	0.40				0.50				
Weight ¹⁾	kg	227				240				
UL 03										
Cutting width	mm	1,500								
Capacity	m ³	0.60								
Weight ¹⁾	kg	368								

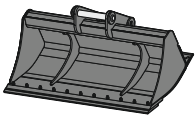

Ditch cleaning bucket rigid

GRL rigid 02										
Mounting		direct mounting, SWA 33 mechanical, SWA 33 hydraulic, SWA 33 Solidlink, SWA 48 mechanical, SWA 48 hydraulic, SWA 48 Solidlink								
Cutting width	mm	1,500	2,000	2,000						
Capacity	m ³	0.50	0.48	0.65						
Weight ¹⁾	kg	362	351	385						
GRL rigid 02B										
Mounting		SWA 33 mechanical, SWA 33 hydraulic, SWA 33 Solidlink								
Cutting width	mm	600	800	1,000	1,200	1,400	1,600	1,800	2,000	
Capacity	m ³	0.17	0.25	0.30	0.38	0.45	0.50	0.57	0.65	
Weight ¹⁾	kg	167	196	225	255	293	330	360	390	

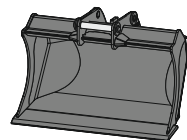

Grading bucket PL 03

Mounting		SWA 33 mechanical, SWA 33 hydraulic, SWA 33 Solidlink, SWA 48 mechanical, SWA 48 hydraulic, SWA 48 Solidlink								
Cutting width	mm	1,400				1,600				
Capacity	m ³	0.65				0.75				
Weight ¹⁾	kg	350				390				

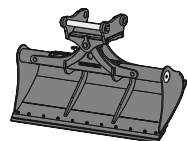

Ditch cleaning bucket with hydraulic cylinder GRL 90

Mounting		direct mounting, SWA 33 mechanical, SWA 33 hydraulic, SWA 33 Solidlink, SWA 48 mechanical, SWA 48 hydraulic, SWA 48 Solidlink										
Cutting width	mm	1,600	1,600	2,000	2,000	2,000	2,200	2,200	2,200	2,400	2,400	2,800
Capacity	m ³	0.55	0.80	0.50	0.70	1.00	0.80	1.15	1.40	0.85	1.25	1.85
Weight ²⁾	kg	690	850	695	875	935	910	985	995	890	1,000	1,090
Tilt angle		2 x 50°	2 x 50°	2 x 50°	2 x 50°	2 x 50°	2 x 50°	2 x 50°	2 x 50°	2 x 50°	2 x 50°	2 x 50°

¹⁾ based on an attachment in a standard design with SWA 33 Solidlink quick coupler mounting

²⁾ based on an attachment in a standard design with SWA 48 Solidlink quick coupler mounting

³⁾ limited digging depth due to mounting for SWA 33 quick coupler

⁴⁾ limited digging depth due to mounting for SWA 48 quick coupler

⁵⁾ reduced capacity with direct mounting

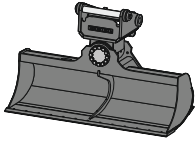

Ditch cleaning bucket with rotary motor GRLM 20

Mounting	SWA 33 mechanical, SWA 33 hydraulic, SWA 33 Solidlink, SWA 48 mechanical, SWA 48 hydraulic, SWA 48 Solidlink				
Cutting width	mm	1,600	1,800	2,000	2,200
Capacity	m ³	0.55	0.65	0.70	0.80
Weight ¹⁾	kg	688	720	753	785
Tilt angle		2 x 50°	2 x 50°	2 x 50°	2 x 50°

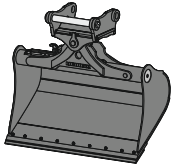

Tilt bucket with hydraulic cylinder SL 90

Mounting	direct mounting, SWA 33 mechanical, SWA 33 hydraulic, SWA 33 Solidlink, SWA 48 mechanical, SWA 48 hydraulic, SWA 48 Solidlink							
Cutting width	mm	1,400	1,500	1,500	1,600	1,600	1,600	
Capacity	m ³	0.55	0.60	1.20	0.80	1.00	1.35	1.55
Weight ²⁾	kg	715	738	970	820	890	970	1,030
Tilt angle		2 x 50°	2 x 50°	2 x 50°	2 x 50°	2 x 50°	2 x 50°	2 x 50°

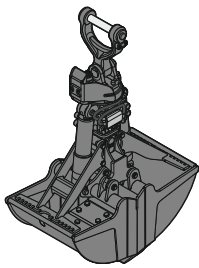

Clamshell grab

Mounting	direct mounting, SWA 33 mechanical, SWA 33 hydraulic, SWA 33 Solidlink, SWA 48 mechanical, SWA 48 hydraulic, SWA 48 Solidlink						
GM 05B Clamshell buckets							
Shell width	mm	300	400	600	800	1,000	
Capacity ³⁾	m ³	0.10	0.13	0.20	0.27	0.34	
Opening width	mm	1,217	1,217	1,217	1,217	1,217	
Weight ⁴⁾	kg	410	445	475	515	590	
GMZ 18 Clamshell buckets							
Shell width	mm	320	400	600	800		
Capacity ³⁾	m ³	0.17	0.22	0.30	0.40		
Opening width	mm	1,462	1,462	1,392	1,392		
Weight ⁴⁾	kg	670	705	715	765		
GMZ 22 Clamshell buckets							
Shell width	mm	300	400	600	800	1,000	
Capacity ³⁾	m ³	0.14	0.20	0.30	0.42	0.54	
Opening width	mm	1,502	1,502	1,502	1,502	1,502	
Weight ⁴⁾	kg	680	710	780	855	935	
GMZ 24 Clamshell buckets							
Shell width	mm	320	400	500	600	800	1,000
Capacity ³⁾	m ³	0.16	0.22	0.28	0.34	0.46	0.60
Opening width	mm	1,515	1,515	1,515	1,515	1,515	1,515
Weight ⁴⁾	kg	720	755	780	815	890	965

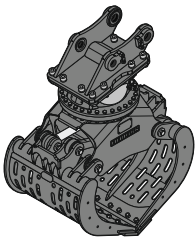

Sorting grab SG 20B

Mounting	direct mounting, SWA 33 mechanical, SWA 33 hydraulic, SWA 33 Solidlink, SWA 48 mechanical, SWA 48 hydraulic, SWA 48 Solidlink								
Shell type	perforated				closed				
Shell width	mm	800	1,000	1,200	1,400	800	1,000	1,200	1,400
Capacity	m ³	0.40	0.50	0.60	0.70	0.40	0.50	0.60	0.70
Max. closing force	kN	40	40	40	40	40	40	40	40
Weight ⁵⁾	kg	750	795	840	885	765	810	850	895

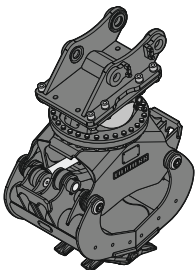

Sorting grab SG 20B with universal shell

Mounting	direct mounting, SWA 33 mechanical, SWA 33 hydraulic, SWA 33 Solidlink, SWA 48 mechanical, SWA 48 hydraulic, SWA 48 Solidlink			
Shell width	mm	650		
Capacity	m ³	0.15		
Max. closing force	kN	57		
Weight ⁶⁾	kg	831		

¹⁾ based on an attachment in a standard design with SWA 33 Solidlink quick coupler mounting

²⁾ based on an attachment in a standard design with SWA 48 Solidlink quick coupler mounting

³⁾ capacity specifications are theoretically determined values; fill level varies depending on the material being loaded

⁴⁾ without suspension

⁵⁾ with standard bolt-on cutting edge, without quick coupler mounting

⁶⁾ with Liebherr teeth Z 35 C, without quick coupler mounting

Attachments

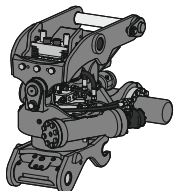

Tiltrotator TR 20B

Mounting machine side	SWA 33 mechanical, SWA 33 hydraulic, SWA 33 Solidlink, SWA 48 mechanical, SWA 48 hydraulic, SWA 48 Solidlink
Mounting attachment side	SWA 33 mechanical, SWA 33 hydraulic, SWA 48 mechanical, SWA 48 hydraulic
Weight ¹⁾	kg 641
Rotation	360°
Tilt	2 x 50°

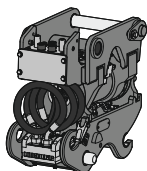

Tilt unit LiTiU 33³⁾

Mounting machine side	SWA 33 Solidlink
Mounting attachment side	SWA 33 hydraulic, SWA 33 Solidlink
Weight ²⁾	kg 410
Tilt	2 x 50°

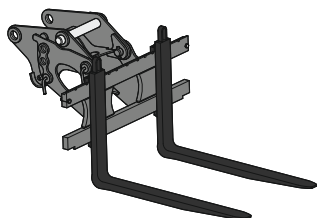

Pallet fork

PG SWA 33 FEM II

Mounting	SWA 33 mechanical, SWA 33 hydraulic, SWA 33 Solidlink
Fork length	mm 1,200 1,400
Max. width pallet fork	mm 1,245 1,245
Lift capacity (ISO 2328)	t 2.5 2.5
Weight	kg 330 363

PG SWA 33 FEM III

Mounting	SWA 33 mechanical, SWA 33 hydraulic, SWA 33 Solidlink
Fork length	mm 1,200 1,500
Max. width pallet fork	mm 1,500 1,500
Lift capacity (ISO 2328)	t 5.0 5.0
Weight	kg 579 620

PG SWA 48 FEM II

Mounting	SWA 48 mechanical, SWA 48 hydraulic, SWA 48 Solidlink
Fork length	mm 1,200 1,400
Max. width pallet fork	mm 1,245 1,245
Lift capacity (ISO 2328)	t 2.5 2.5
Weight	kg 345 378

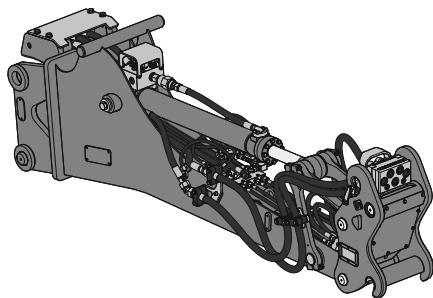

Stick extension LS 12

Mounting machine side	SWA 33 mechanical, SWA 33 hydraulic, SWA 33 Solidlink, SWA 33 Solidlink-9, SWA 48 mechanical, SWA 48 hydraulic, SWA 48 Solidlink, SWA 48 Solidlink-10
Mountings attachment side	direct mounting, SWA 33 mechanical, SWA 33 mechanical Solidlink ⁶⁾ , SWA 33 hydraulic ⁷⁾ , SWA 33 Solidlink ⁶⁾⁷⁾⁸⁾
Length	m 2.25 2.70
Weight ⁴⁾	kg 650 700

¹⁾ based on standard tiltrotator TR 20B with SWA 33 Solidlink quick coupler mounting machine side and SWA 33 hydraulic quick coupler mounting on the underside tiltrotator

²⁾ based on standard tilt unit LiTiU 33 with SWA 33 Solidlink quick coupler mountings on both sides (underside of tilt unit and machine side quick coupler mounting)

³⁾ on the machine side, a 14-pin signal contact strip is always required; switching takes place between tilting the LiTiU and the grab rotation circle for the attachment

⁴⁾ based on standard stick extension LS 12 with SWA 33 Solidlink quick coupler mountings on both sides (underside of stick extension and machine side mounting) and electric switchover

⁵⁾ attachment with high pressure circuit only possible with the manual switchover tipping cylinder or an extended hydraulic circuit on the carrier machine

⁶⁾ attachment with high pressure circuit only possible with the electric / manual switchover tipping cylinder or an extended hydraulic circuit on the carrier machine

⁷⁾ 14-pin signal contact strip is required, for example to control and monitor the hydraulic quick coupling system on the stick extension on the attachment side or to transfer electrical signals for the switchover

⁸⁾ to use different hydraulic circuits, either Solidlink 33-9 / Solidlink 48-10 is required on the machine side, or a switchover system using the equipment power socket, controlled via the carrier machine's signal contact strip

Equipment

Undercarriage

General	
Trailer coupling with bolt (diameter of towing eye 40 mm), automatic (outrigger support)	+
Trailer coupling with bolt (diameter of towing eye 40 mm), automatic (blade support)	+
Hydraulic connection for tipping the trailer (single-acting tipping cylinder)	+
Mudguards (rear and front)	+
Lubrication undercarriage (decentral), manual (grease points)	+
Storage box left, incl. base plate	+
Storage box with drawer left	+
Storage box with drawer right	+
Storage box right, incl. base plate	+
Socket for lighting extension coupling, 24 V, ISO 1724 (rear)	+
Centralised lubrication manual undercarriage (one grease point)	+
Stabilization & driving	
Rear stabilizer blade 2,550 mm	+
Rear stabilizer blade 2,750 mm	+
Individual control, two outriggers	+
Piston rod guard for rear outriggers and front blade	+
Piston rod guard for rear blade	+
Piston rod guard for rear blade and front outriggers	+
Automatic swing axle lock	●
Rear outriggers, front stabilizer blade 2,550 mm	+
Rear outriggers, front stabilizer blade 2,750 mm	+
Single tyres, Alliance HD I-331 600/40-22.5	+
Single tyres, Michelin XF-445/70R19.5	+
Speeder 30 km/h	+
Speeder 37 km/h	+
Undercarriage EW 2,750 mm wide	+
Twin tyres, Liebherr EM 22, 290/90-20 PR 18	+
Twin tyres, Mitas EM-22, 10.00-20 PR 16	+

Uppercarriage

General	
Extended tool kit including toolbox	+
Licence plate holder with light	+
Amber beacon on uppercarriage, rear, LED, 1 piece*	+
Storage box in the uppercarriage	●
Centralised lubrication automatic swing ring and equipment	●
Hydraulic & engine	
Tank refilling pump fuel	+
Hydraulic oil, Liebherr Hydraulic Basic 100 (0 to +55 °C)	+
Hydraulic oil, Liebherr Hydraulic HVI (-20 to +40 °C)	+
Hydraulic oil, Liebherr Hydraulic Plus 37 (-30 to +40 °C)*	+
Hydraulic oil, Liebherr Hydraulic Plus Arctic, high performance oil (-40 to +30 °C)	+
Hydraulic oil, Liebherr Hydraulic Plus, high performance oil (-30 to +45 °C)	+
Reversible fan drive	+
Air pre-filter with cyclonical dust trap	+
Automatic engine shutdown after idling (with timer)	+
Automatic engine shutdown after idling (without timer)	+
Bypass filter for hydraulic oil	+
Power Pack EU Stage V*	+
Power Pack USA Tier 4 Final*	+
Lubricants and operating fluids Standard (-20 to +40 °C)	●
Preheating fuel*	+

Equipment

Boom	
PowerLift	●
Pipe fracture safety valve stick cylinder	●
Floating boom	+
Two-piece boom 4.85 m	+
Offset two-piece boom 4.90 m	+
Stick & attachment mounting	
GPS for attachment (via 5-pin signal contacts)	+
GPS for attachment (via 14-pin signal contacts)	+
Coupling system Solidlink 33-9 for quick coupler SWA 33	+
Coupling system Solidlink 48-10 for quick coupler SWA 48	+
Coupling system Solidlink for quick coupler SWA 33	+
Coupling system Solidlink for quick coupler SWA 48	+
Load holding valve for tipping cylinder	+
Load holding valve for tipping cylinder (both sides)	+
Lifting eye on stick 8.0t (500 mm from stick end pin)	+
Lifting eye on stick 8.0t (1,000 mm from stick end pin)	+
Stick 2.25 m	+
Stick 2.45 m	+
Stick 2.65 m	+
Quick coupler SWA 33 hydraulic	+
Quick coupler SWA 48 hydraulic	+
Hydraulic hose guard Solidlink	+
Tilt unit LiTiU 18 direct mounting	+
Tilt unit LiTiU 18 direct mounting with Solidlink	+
Signal contacts for Solidlink 5-pin	+
Signal contacts for Solidlink 5-pin and 14-pin	+
Signal contacts for Solidlink 14-pin	+
Socket on stick (24 V)	+
Connection via signal contacts for Solidlink (24 V)	+
Centralised lubrication automatic quick coupler	+
Centralised lubrication automatic connecting link	+

Equipment



Cab

Interior	
2-points seat belt, 2"	+
3-points seat belt, 2"	+
Storage tablet	●
Mood lighting LED	●
Armrests adjustable in length, height and inclination	●
Double pedal, left	+
Operator's seat Comfort	+
Operator's seat Premium	+
Operator's seat cover	+
Travel alarm system switchable	+
Fire extinguisher*	+
Air-conditioned bottle holder	●
Footrest	●
Seat belt reminder	●
Mobile phone holder with inductive charging	+
Automatic air conditioning	●
Wheel and joystick steering	+
Wheel steering	+
Multifunction mounting bracket	+
Radio Comfort	●
Acoustic back-up warning system not switchable	+
Additional roll-down sun blind for windscreen	+
Roll-down sun blinds for windscreen and roof window	●
Roll-down sun blinds for rear and side window, right	+
Auxiliary heater programmable	+
Air-conditioned storage compartment	●
Socket in cab (24 V)	●
Sockets in cab (USB)	●
First-aid box	+
Warning triangle	+
Exterior	
Rearview mirror	+
Electrically adjustable and heated outside rear-view mirrors	+
Cab air filters, accessible from ground level	●
Lightbar on cab, LED	+
Warning beacon foldable on cab, LED, 1 piece	+
Roof window wiper	+
FOPS top guard flat	+
FOPS top guard	+
FGPS front guard with side opening	+
Retractable laminated two-piece windscreen	+

General

Liebherr Connect	
MyLiebherr Maintenance	+
MyLiebherr Performance	+
MyLiebherr Portal ¹⁾	●

● = Standard, + = Option

* country-dependent, ¹⁾ free activation required

Options and /or special equipment, supplied by vendors other than Liebherr, are only to be installed with the knowledge and approval of Liebherr in order to retain warranty.



Control

Safety & operation	
Digging brake, automatic	●
Ride control	+
Boom cylinder cushioning	+
Modetronic	●
Positioning swing brake automatic	+
Positioning swing brake automatic and manual	+
Overload warning system	●
Hydraulic & control	
10" colour touchscreen	●
Control pattern digital	●
Attachment continuous operation system	+
Display with haptic feedback	●
Grapple lines for stick with tipping kinematic	+
High pressure circuit with Tool Control	+
Joysticks Premium	●
Fuel level on touchscreen	●
Leak oil lines for attachment	+
Mowing-bucket operation	+
Medium pressure circuit	●
Mode selector	●
Power Plus for Tools	+
Filter for hydraulic hammer return flow	+
Touchpad 3.5"	●
Preparation for tiltrotator	+
Assistance systems	
Working envelope limitation Advanced	●
Cruise control	●
Integral tyre pressure monitoring system	+
Machine control 2D	●
Machine control 3D Leica	+
Machine control 3D ready Leica	+
MiC 4.0 BUS communication standard	●
Smartphone interface	●
Skyview 360°	+
Smart Key Comfort	+
Smart Key Standard	+
Preparation for machine control system	+



Packages

Light package Comfort	+
Light package Standard	+
Light package Stick	+
Light package Surround	+

Liebherr-Hydraulikbagger GmbH

Liebherrstraße 12 · 88457 Kirchdorf (Iller), Germany · Phone +49 7354 80-0

info.lhb@liebherr.com · www.liebherr.com · www.facebook.com/LiebherrConstruction