L 550 – L 586 XPower

LIEBHERR

Wheel loaders



Generation
6

Tipping load
12,500 kg–21,600 kg

Diesel engine
Stage V
Stage IV – only for
select markets

Performance

More power, greater productivity – increased performance through an innovative travel drive

Economy

Efficient performance guaranteed – low costs with high turnover rate

Reliability

A reliable partner – robust and durable machines

Comfort

Sophisticated design – when technology combines comfort and safety

Maintainability

Savings in both time and costs – thanks to quick and simple maintenance



L 550 XPower

Tipping load, articulated
12,500 kg
Bucket capacity
3.4 m³
Operating weight
18,550 kg
Engine output
163 kW / 222 HP

L 556 XPower

Tipping load, articulated
13,750 kg
Bucket capacity
3.7 m³
Operating weight
19,600 kg
Engine output
183 kW / 249 HP



L 566 XPower

Tipping load, articulated
15,900 kg
Bucket capacity
4.2 m³
Operating weight
23,900 kg
Engine output
203 kW / 276 HP

L 576 XPower

Tipping load, articulated
17,600 kg
Bucket capacity
4.7 m³
Operating weight
25,700 kg
Engine output
218 kW / 296 HP

L 580 XPower

Tipping load, articulated
19,200 kg
Bucket capacity
5.2 m³
Operating weight
27,650 kg
Engine output
233 kW / 317 HP

L 586 XPower

Tipping load, articulated
21,600 kg
Bucket capacity
6.0 m³
Operating weight
32,600 kg
Engine output
263 kW / 358 HP

Performance



More power, greater productivity – increased performance through an innovative travel drive

The innovative Liebherr-XPower travel drive combines the best features of two types of drive into a unique machine concept. Faster work cycles, high tipping loads, and increased machine availability result in significant handling capacity.

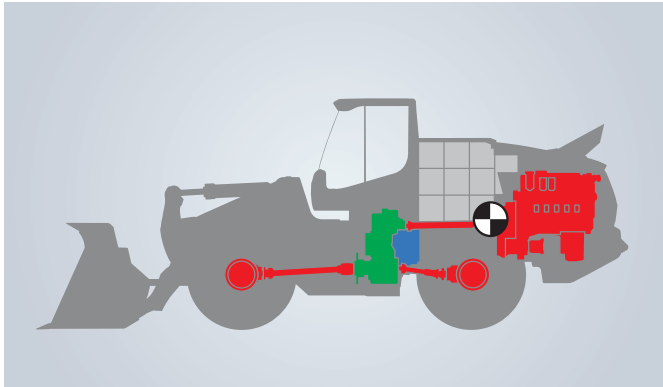

Powerful machine concept

- The drive components installed in the rear of the wheel loader act as a natural counterweight and are part of the sophisticated ballast concept
- Ideal weight distribution results in higher tipping loads and therefore greater productivity
- Balanced operating mass increases efficiency and saves fuel
- Strong designs and robust steel parts ensure a reliable and powerful machine



Maximum performance

- Liebherr-XPower travel drive combines hydrostatic and mechanical drives
- Interaction of the two drive types is automatically and continuously adapted to the respective operation
- XPower offers the highest efficiency in material pick-up and transport as well as optimum acceleration and maximum performance in all loading cycles



Lift arm variations operationally optimised

- Standard z-bar kinematics provide high torque in the lower lift arm range
- Particularly suitable for conventional wheel loader operations due to quick and easy filling of the bucket
- Industrial lift arms (for L 550 - L 566 / L 580) scores with parallel movement and offer particularly high torque in the upper lift arm range
- Particularly suitable for industrial use, large working attachments, and heavier loads



Great versatility for the optimum handling of material

- Due to the diverse selection of factory-made working attachments the right tool is always available
- The robust bucket design enables the bucket to be filled fast and efficiently
- Excellent bucket penetration and easy bucket filling result in lower fuel consumption
- Modular bucket design for L 550 and L 556 G6.2 allows individual configuration, suitable for every application

Economy



Efficient performance guaranteed – low costs with high turnover rate

Power, speed, and durability combined with innovative technology result in an optimum machine design that makes a reliable contribution to cost-effective success. The efficient Liebherr-XPower travel drive and the robust components reduce operating costs in a sustainable way.



Maximum productivity with minimum fuel consumption

- Liebherr power efficiency (LPE) optimises the interaction between the diesel engine, transmission, and working hydraulics for maximum efficiency
- Liebherr-XPower travel drive with LPE provides enormous fuel savings
- At the highest efficiency, operating costs are reduced, and profitability is increased



Minimum wear due to intelligent machine concept

- Virtually no brake wear due to the hydraulic-mechanical braking action
- Continuous tractive force control combined with automatic self-locking differentials prevents wheel spin, thereby increasing productivity and significantly reducing tyre wear



Liebherr Connect

- Intelligent machine networking with digital services and machine and process data
- For use in fleet and asset management systems and monitoring the condition of machines and components
- Efficient data exchange with customisation of the machine

MyLiebherr Portal

- Extensive benefits, digital services and software solutions for efficient machine operation
- Machine management, spare part orders and licence acquisition following one-time registration



Solidlink

- Optional available, hydraulic quick coupler with integrated automatic hydraulic coupling system
- Hydraulic working tools changed within seconds directly from the cab
- Change is fully automatic, safe and leak-free
- Time savings thanks to greater convenience lead to increased performance, saving time and money

Reliability



A reliable partner – robust and durable machines

Tried and tested over decades with proven excellence – the specially developed components of Liebherr wheel loaders demonstrate their sophisticated technology and durability. The high degree of quality offers maximum reliability and availability even under the toughest operating conditions.



High performance and long-lasting components

- Decades of experience in the development, design and production of individual components is reflected in their robustness and durability
- Elements are ideally matched for maximum performance
- High Liebherr quality standards ensure reliability even under the toughest operating conditions



Working without interruption

- Diesel oxidation catalysts (DOC) and diesel particulate filters (DPF) as well as selective catalytic reduction (SCR) are installed for exhaust gas treatment, and lower pollutant emissions
- The diesel particulate filter can be unblocked during operation via active regeneration, thus enabling an uninterrupted work process
- Long intervals between regenerations increase productivity, save fuel, and reduce operating costs

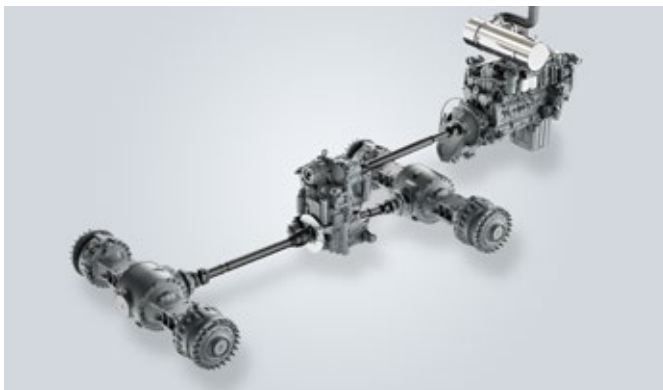

Reliable Liebherr drive design

- Variable distribution of forces between the hydrostatic and mechanical drives result in less stress on each of the drive paths
- Long service life and reliable use of the machine thanks to Liebherr-XPower travel drive



Optimal cooling capacity

- The radiator is installed behind the operator's cab – the cleanest place on the wheel loader
- Demand-controlled cooling via thermostatic control for reliable operation
- High machine availability due to less radiator contamination
- The optional equipments such as the reversible fan drive, lint filter for the radiator, and the coarse-mesh radiator, additionally protect the cooling system from contamination

Comfort



Sophisticated design – when technology combines comfort and safety

A feel-good cab – the modern cab design is optimally adapted to the day-to-day needs of the operators. The spacious and ergonomically designed operator's cab provides the perfect conditions for comfortable and productive working and can be individually adjusted to the operator.



Modern cab design for greater productivity

- Modern ergonomic cab design enables focused working with less fatigue
- Displays, control elements and operator's seat are perfectly aligned with one another to form an ergonomic unit
- For the operator, the individual adjustment options on the operator's seat and the steering wheel create a comfortable work atmosphere with plenty of legroom
- Numerous storage compartments provide lots of space in the cab on all sides



Keep an eye on everything – for hazard-free work

- The extensive use of glass in the operator's cab provides excellent all-round visibility of the working attachment and operating area
- The engine bonnet was designed with optimised visibility in mind and this together with the integrated reversing camera ensure an excellent overview and thus provide greater safety
- Height-adjustable 9" touch screen display provides all operating-relevant machine data at a glance

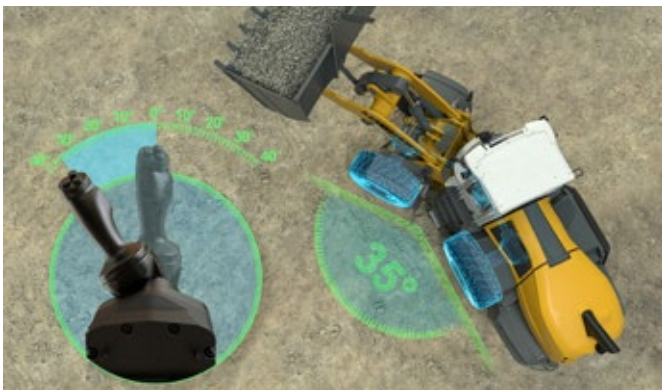

Innovative joystick steering

- Optional joystick steering is integrated into the operator's seat for ergonomic and comfortable operation
- Intuitive operating behaviour resembles that of a steering wheel
- The alignment of the joystick corresponds to the required wheel loader articulation angle
- Speed-dependent force feedback ensures precise and safe steering behaviour
- "Joystick steering only" enables operation in an operator's cab without a steering wheel and steering column



Assistance systems – increase safety conveniently

- Active personnel detection monitors the rear area of the wheel loader and warns of hazards with a visual and acoustic signal
- Tyre pressure monitoring system transmits tyre pressure values directly to the driver display
- Skyview 360° simplifies monitoring close surroundings of the entire machine on a separate display in the operator's cab
- The weighing device with "Truck Payload Assistant" ensures faster and more accurate loading cycles
- Further assistance systems are available at customer request

Maintainability



Savings in both time and costs – thanks to quick and simple maintenance

Intelligent installation of components, quick and easy access to the engine compartment, and maximum efficiency down to the smallest detail are crucial for effective maintenance work. All installed parts which need to be serviced can be reached safely and quickly. This saves time and costs.



Safe and sophisticated service access

- Electrically rear-opening engine bonnet provides safe and easy access to the entire engine compartment
- All maintenance work can be conveniently performed from a platform in the engine bonnet
- Improved access to the front windscreen / cab filter box is provided by the cab access on the right side of the machine
- Non-slip treads and sturdy handrails ensure maximum safety when cleaning
- Quick and simple maintenance reduces standstill times, increases productivity and saves money



Low maintenance effort due to intelligent construction

- Simple and safe maintenance ensures less downtime
- Less contamination of the radiator due to its intelligent position directly behind the operator's cab
- The most important fill levels can be seen in the entry area



MyLiebherr Maintenance

- Current information on the condition of the machine and attachments
- Reduced unplanned machine standstills thanks to practical recommendations and proactive maintenance planning
- Time saved when identifying, evaluating and solving problems

My Liebherr Performance

- Information on the performance data from the machines and attachments
- Efficient solutions for saving fuel and reducing idle times



Liebherr customer service

- Comprehensive service network provides effective and prompt support
- Fast and reliable service implementation by qualified service specialists

Focus on innovation and safety



Lift arms

Cleverly designed – one wheel loader, two lift arm variants, and numerous application options – while the standard z-bar kinematics ensure high torque in the lower lift arm position, the industrial kinematics provide optimum, parallel movement, and particularly high torque in the upper lift arm position. This means that the XPower wheel loaders are optimally equipped for any task and can perform the work powerfully and efficiently.

Drive concept

Powerful performance – the Liebherr-XPower travel drive combines the hydrostatic drive for short loading cycles, with the mechanical drive for long distances and inclines. The standard combination of these two drive types offers the highest efficiency in all application areas and results in a lower load on the respective drive path.



Machine networking

Liebherr Connect networks the machine into the digital world. Intelligent machine networking provides access to digital services as well as machine and process data. The system ensures an efficient data exchange and offers various options to further develop the machine and customise it to individual customer requirements.

Comfort

Intuitive and comfortable – the ergonomically optimised cab design enables comfortable and less tiring work. The large glazed area and the visibility-optimised engine bonnet design provide an unobstructed view in all directions. The joystick steering allows precise and productive work through intuitive and exact control. The optional “joystick steering only” provides an even better view of the lift arms and the working attachment as well as more space in the operator’s cab.

Assistance systems

Intelligent helpers – the innovative assistance systems offer comprehensive solutions to optimise safety and comfort, supporting the operator and therefore increase performance. The simple handling and intuitive operation enable safe, efficient, and therefore more economical machine operation.

Maintenance

Safer service – the unique installation position of the components results in excellent maintenance accessibility. Supported by the latest technology, you have safe and easy access to the entire engine compartment. Short downtimes and fast maintenance work lead to greater productivity and a higher profitability of the machine.

Technical data

Diesel engine

	L 550	L 556
Diesel engine	D934 A7	D944 A7
Design	Water-cooled in-series engine with charge-air cooling	
Cylinder inline	4	
Fuel injection process	Electronic Common Rail high-pressure injection	
Output to	kW / HP	160 / 218
ISO 9249 / ECE-R.24	at RPM	1.800
Rated output to		
ISO 14396 / ECE-R.120	kW / HP	163 / 222
Nominal speed	at RPM	1.800
Max. torque to	Nm	1.248
ISO 14396 / ECE-R.120	at RPM	1.100
Displacement	litres	7,014
Bore / Stroke	mm	122 / 150
Stage IV – available only in select markets		
Harmful emissions values	According to regulation ECE-R.96 Power Band Q	
Emission control	litres Liebherr-SCR technology	
Stage V		
Harmful emissions values	According to regulation (EU) 2016/1628	
Emission control	Liebherr-SCR technology and closed diesel particle filter system	
Air cleaner system		
	Dry type filter with main and safety element, pre-cleaner, service indicator on the Liebherr display	
Electrical system		
Operating voltage	V	24
Capacity	Ah	2 x 140
Alternator	V / A	28 / 140
Starter	V / kW	24 / 7.8

Driveline

Continuous power split XPower driveline	
Design	Continuous, fully-automatic XPower driveline. No traction interruptions across the entire speed range. Hydrostatic power split with two axial piston units. Identical driving performance – forwards and in reverse
Filtration	Filter system for driveline, depend on working hydraulics
Control	Driveline is controlled from travel pedal for tractive force and speed setting with integrated inch function. The Liebherr control lever is used to control forward and reverse travel
Travel speed range	0 - 40* km/h forward and reverse, fully-automatic Speed restriction available upon request. Speeds quoted apply with the tyres indicated as standard on loader model.

* Configuration, tyres and mounting tools can influence the maximum speed.

Brakes

Wear-free service brake	Self-locking of the XPower driveline (acting on all four wheels) and additional pump-accumulator brake system with wet multi-disc brakes (two separate brake circuits)
Parking brake	Electro-hydraulically actuated spring-loaded disc brake system on the transmission

The braking system meets the requirements of the ISO 3450.

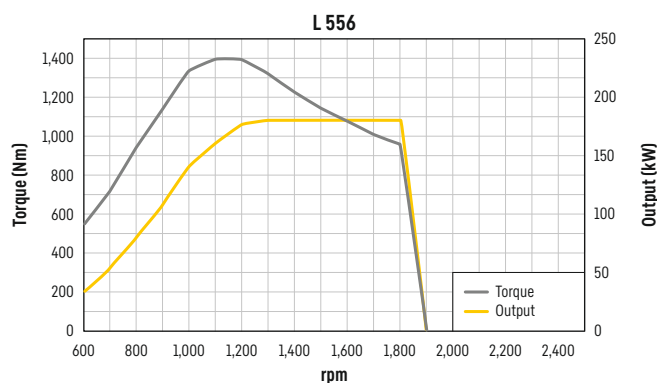
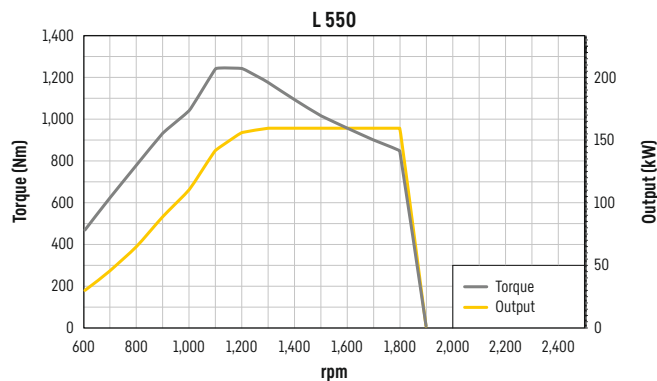

 **Axles**

	L 550	L 556
Four-wheel drive		
Front axle	Fixed	
Rear axle	Centre pivot, with 13° oscillating angle to each side	
Height of obstacles which can be driven over	mm	440
	with all four wheels remaining in contact with the ground	
Differentials	Automatic limited-slip differentials	
Reduction gear	Planetary final drive in wheel hubs	
Track width	2,003 mm with all types of tyres	

 **Steering**

Design	"Load-sensing" swash plate type variable flow pump with output and flow control. Central pivot with two double-acting, damped steering cylinders		
Angle of articulation	40° to each side		
Emergency steering	Electro-hydraulic emergency steering system		

 **Attachment hydraulics**

	L 550	L 556
Design	"Load-sensing" swash plate type variable flow pump with output and flow control, and pressure cut-off in the control block	
Cooling	Hydraulic oil cooling using thermostatically controlled fan and oil cooler	
Filtration	Return line filter in the hydraulic reservoir	
Control	Liebherr control lever, electro-hydraulically operated	
Lifting function	Lifting, neutral, lowering Automatic lift arm position and lowering by Liebherr control lever	
Tilt function	Float position controlled by Liebherr control lever Tilt back, neutral, dump Automatic bucket return for tilting back and dumping controlled by Liebherr control lever	
Max. flow	l/min.	234
Max. pressure		290
Z-bar kinematics	bar	350
Industrial lift arm	bar	380

 **Attachment**

	L 550		L 556	
Geometry variants				
Optional	Powerful Z-bar kinematics with tilt cylinder and cast steel cross-tube Industrial lift arm with tilt cylinder, hydraulic quick hitch as standard			
Bearings	Sealed			
Cycle time at nominal load	ZK	IND	ZK	IND
Lifting	s	5.4	5.4	5.4
Dumping	s	1.0	2.2	1.0
Lowering (empty)	s	2.9	2.9	2.9

 **Operator's cab**

Design	Hydraulically mounted, noise-proof cab ROPS roll over protection per EN ISO 3471 / EN 474-1 FOPS falling objects protection per EN ISO 3449 / EN 474-1, Cat. II Operator's door with sliding side window, sliding side window on right, front windscreen made of compound safety glass, side panels with single-pane safety glass ESG, heated rear window ESG, all windows are tinted. 3 way continuous adjustable steering column		
Liebherr operator's seat	6 way adjustable, vibration-damped operator's seat "Comfort" with seat, depth and incline adjustment as standard (air-cushioned with seat heating adjustable to operator's weight), Liebherr control lever mounted into the operator's seat as standard		
Cab heating and ventilation	4-zone air conditioning with new improved cooling output as standard, electrically heated rear window, all filters are easy to access and replaceable		
Vibration emissions			
Hand / arm vibrations	≤ 2.5 m/s ² , according with ISO 5349-1:2001		
Whole-body vibrations	≤ 0.5 m/s ² , complies with technical report ISO/TR 25398:2006		
Measuring inaccuracy	According with standard EN 12096:1997		

 **Sound level**

	L 550	L 556
Sound pressure level to ISO 6396		
L _{PA} (inside cab)	dB(A)	68
Sound power level to 2000/14/EC		
L _{WA} (surround noise)	dB(A)	104

 **Capacities**

	L 550	L 556
Fuel tank	l	280
DEF tank	l	67.5
Engine oil (inclusive filter change)	l	26
Pump distribution gearbox	l	1.2
XPower gearbox	l	53
Coolant	l	67
Front axle	l	35
Rear axle	l	35
Hydraulic tank	l	105
Hydraulic system, total	l	175
Air conditioning system R134a	g	1,250

Dimensions

Z-bar kinematics

L 550 – L 556

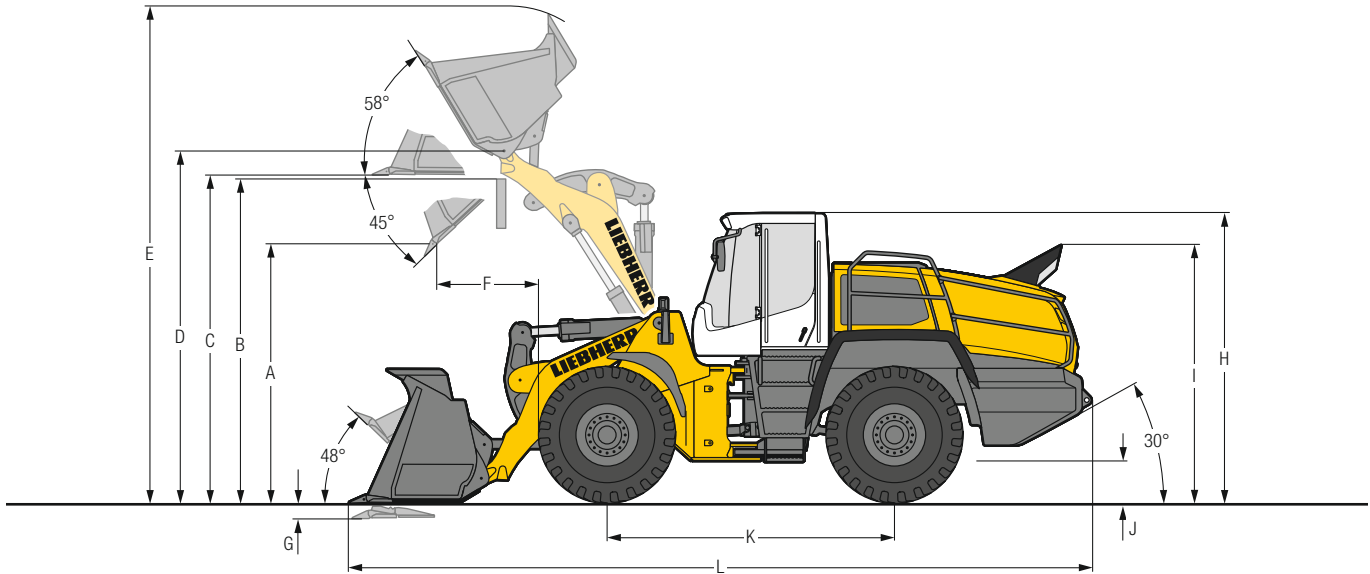

Excavation bucket

	L 550				L 556				
	STD	STD	HL	HL	STD	STD	HL	HL	
Geometry	ZK	ZK	ZK	ZK	ZK	ZK	ZK	ZK	
Cutting tools	Z	Z	Z	Z	Z	Z	Z	Z	
Lift arm length	mm	2,700	2,700	3,100	3,100	2,700	2,700	3,100	3,100
Bucket capacity according to ISO 7546 **	m ³	3.4	3.7	2.8	3.1	3.7	4.1	3.1	3.4
Specific material density	t/m ³	1.8	1.6	1.8	1.6	1.8	1.6	1.8	1.6
Bucket width	mm	2,880	2,880	2,880	2,880	2,880	2,880	2,880	2,880
A Dumping height at max. lift height and 45° discharge	mm	3,020	2,970	3,715	3,670	2,970	2,900	3,670	3,575
B Dump-over height	mm	3,700	3,700	4,200	4,200	3,700	3,700	4,200	4,200
C Max. height of bucket bottom	mm	3,875	3,875	4,430	4,430	3,875	3,875	4,430	4,430
D Max. height of bucket pivot point	mm	4,150	4,150	4,700	4,700	4,150	4,150	4,700	4,700
E Max. operating height	mm	5,785	5,855	6,185	6,255	5,855	5,960	6,255	6,340
F Reach at max. lift height and 45° discharge	mm	1,025	1,075	840	890	1,075	1,145	890	945
G Digging depth	mm	80	80	95	95	80	80	95	95
H Height above operator's cab	mm	3,370	3,370	3,370	3,370	3,370	3,370	3,370	3,370
I Height above exhaust	mm	3,020	3,020	3,020	3,020	3,020	3,020	3,020	3,020
J Ground clearance	mm	490	490	490	490	490	490	490	490
K Wheelbase	mm	3,500	3,500	3,500	3,500	3,500	3,500	3,500	3,500
L Overall length	mm	8,555	8,625	9,000	9,070	8,625	8,725	9,070	9,150
Turning circle radius over tyres	mm	6,155	6,155	6,155	6,155	6,155	6,155	6,155	6,155
Turning circle radius over outside bucket edge	mm	6,840	6,860	7,025	7,045	6,860	6,885	7,045	7,070
Breakout force (SAE)	kN	165	155	175	165	175	165	185	175
Tipping load, straight *	kg	14,050	13,950	11,700	11,600	15,600	15,400	13,000	12,900
Tipping load, fully articulated *	kg	12,500	12,400	10,250	10,150	13,750	13,550	11,350	11,250
Operating weight *	kg	18,550	18,650	18,750	18,800	19,600	19,700	19,800	19,850
Tyre size		23,5R25 L3		23,5R25 L3		23,5R25 L3		23,5R25 L3	

* The figures shown include the above tyres, all lubricants, a full fuel tank, the ROPS / FOPS cab and the operator. Different tyres and optional equipment will change the operating weight and tipping load. (Tipping load, fully articulated according to ISO 14397-1)

** Actual bucket capacity may be approx. 10% larger than the calculation according to ISO 7546 standard. The degree to which the bucket can be filled depends on the material – see page 24.

- STD = Standard lift arm length
- HL = High Lift
- ZK = Z-bar kinematics
- Z = Welded-on tooth holder with add-on teeth

Dimensions

Industrial lift arm

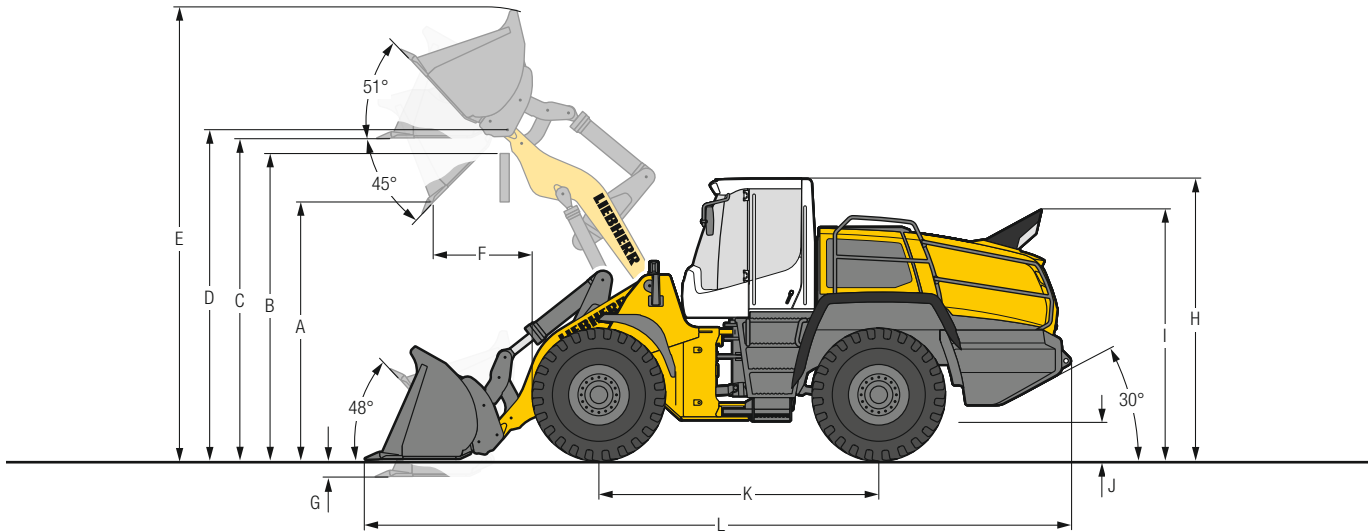

Excavation bucket

	L 550			L 556		
	STD IND-QH	HL IND-QH	HL IND-QH	STD IND-QH	HL IND-QH	HL IND-QH
Geometry						
Cutting tools	T	T	T	T	T	T
Lift arm length	mm 2,700	3,000	3,000	2,700	3,000	3,000
Bucket capacity according to ISO 7546**	m ³ 3.1	2.6	2.8	3.4	2.8	3.1
Specific material density	t/m ³ 1.8	1.8	1.6	1.8	1.8	1.6
Bucket width	mm 2,880	2,880	2,880	2,880	2,880	2,880
A Dumping height at max. lift height and 45° discharge	mm 2,920	3,525	3,490	2,870	3,490	3,440
B Dump-over height	mm 3,700	4,100	4,100	3,700	4,100	4,100
C Max. height of bucket bottom	mm 3,865	4,385	4,385	3,865	4,385	4,385
D Max. height of bucket pivot point	mm 4,145	4,665	4,665	4,145	4,665	4,665
E Max. operating height	mm 5,845	6,240	6,290	5,925	6,290	6,365
F Reach at max. lift height and 45° discharge	mm 1,150	835	870	1,210	870	920
G Digging depth	mm 100	100	100	100	100	100
H Height above operator's cab	mm 3,370	3,370	3,370	3,370	3,370	3,370
I Height above exhaust	mm 3,020	3,020	3,020	3,020	3,020	3,020
J Ground clearance	mm 490	490	490	490	490	490
K Wheelbase	mm 3,500	3,500	3,500	3,500	3,500	3,500
L Overall length	mm 8,785	9,025	9,075	8,865	9,075	9,145
Turning circle radius over tyres	mm 6,155	6,155	6,155	6,155	6,155	6,155
Turning circle radius over outside bucket edge	mm 6,875	6,980	7,000	6,895	7,000	7,020
Breakout force (SAE)	kN 140	150	145	155	175	165
Tipping load, straight*	kg 12,900	11,200	11,100	14,300	12,400	12,300
Tipping load, fully articulated*	kg 11,400	9,800	9,700	12,500	10,800	10,700
Operating weight*	kg 19,200	19,300	19,350	20,200	20,300	20,350
Tyre size	23.5R25 L3			23.5R25 L3		

* The figures shown include the above tyres, all lubricants, a full fuel tank, the ROPS/FOPS cab and the operator. Different tyres and optional equipment will change the operating weight and tipping load. (Tipping load, fully articulated according to ISO 14397-1)

** Actual bucket capacity may be approx. 10% larger than the calculation according to ISO 7546 standard. The degree to which the bucket can be filled depends on the material – see page 24.

STD = Standard lift arm length

HL = High Lift

IND-QH = Industrial lift arm with parallel guidance incl. quick hitch

T = Welded-on tooth holder with add-on teeth

Attachment

Light material bucket

L 550 – L 556

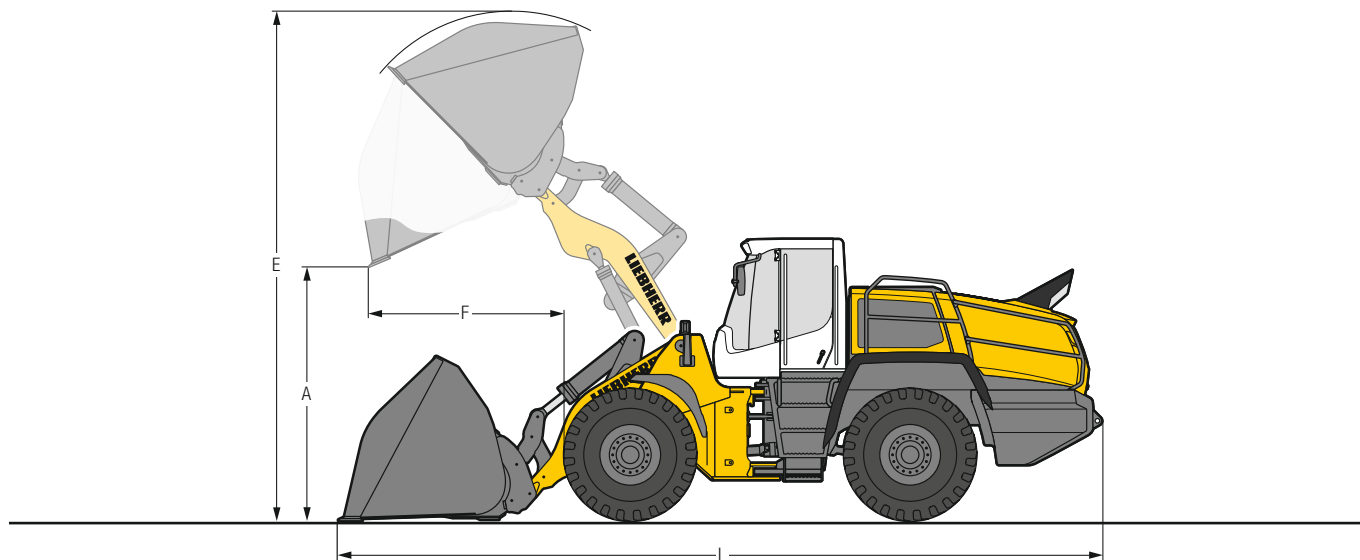

Heavy material density

	L 550		L 556	
	STD	HL	STD	HL
Geometry	IND-QH	IND-QH	IND-QH	IND-QH
Cutting tools	BOCE	BOCE	BOCE	BOCE
Bucket capacity	m ³ 5.0	4.5	5.5	5.0
Specific material density	t/m ³ 1.0	1.0	1.0	1.0
Bucket width	mm 2,950	2,950	2,950	2,950
A Dumping height at max. lift height	mm 2,630	3,190	2,530	3,145
E Max. operating height	mm 5,975	6,560	6,040	6,490
F Reach at maximum lift height	mm 1,420	1,120	1,500	1,185
L Overall length	mm 8,970	9,245	9,105	9,330
Tipping load, straight*	kg 12,200	10,600	13,600	11,800
Tipping load, fully articulated*	kg 10,600	9,200	11,700	10,200
Operating weight*	kg 19,500	19,600	20,500	20,600
Tyre size	23.5R25 L3		23.5R25 L3	



Light material density

	L 550		L 556	
	STD	HL	STD	HL
Geometry	IND-QH	IND-QH	IND-QH	IND-QH
Cutting tools	BOCE	BOCE	BOCE	BOCE
Bucket capacity	m ³ 9.5	8.5	10.0	9.0
Specific material density	t/m ³ 0.5	0.5	0.5	0.5
Bucket width	mm 3,400	3,400	3,400	3,400
A Dumping height at max. lift height	mm 2,320	2,910	2,300	2,870
E Max. operating height	mm 6,240	6,730	6,245	6,760
F Reach at maximum lift height	mm 1,740	1,435	1,740	1,475
L Overall length	mm 9,415	9,670	9,435	9,730
Tipping load, straight*	kg 11,900	10,200	13,300	11,300
Tipping load, fully articulated*	kg 10,200	8,800	11,500	9,700
Operating weight*	kg 20,100	20,200	21,100	21,200
Tyre size	23.5R25 L3		23.5R25 L3	

* The figures shown include the above tyres, all lubricants, a full fuel tank, the ROPS / FOPS cab and the operator. Different tyres and optional equipment will change the operating weight and tipping load. (Tipping load, fully articulated according to ISO 14397-1)

For wheel loaders with large light material buckets and high-dump buckets or log grapples, we supply visual aids such as mirrors or cameras for front area monitoring that meet the requirements of the ISO 5006:2017 field of vision test.

STD = Standard lift arm length

HL = High Lift

IND-QH = Industrial lift arm with parallel guidance incl. quick hitch

BOCE = Bolt-on cutting edge

Attachment

High-Dump bucket

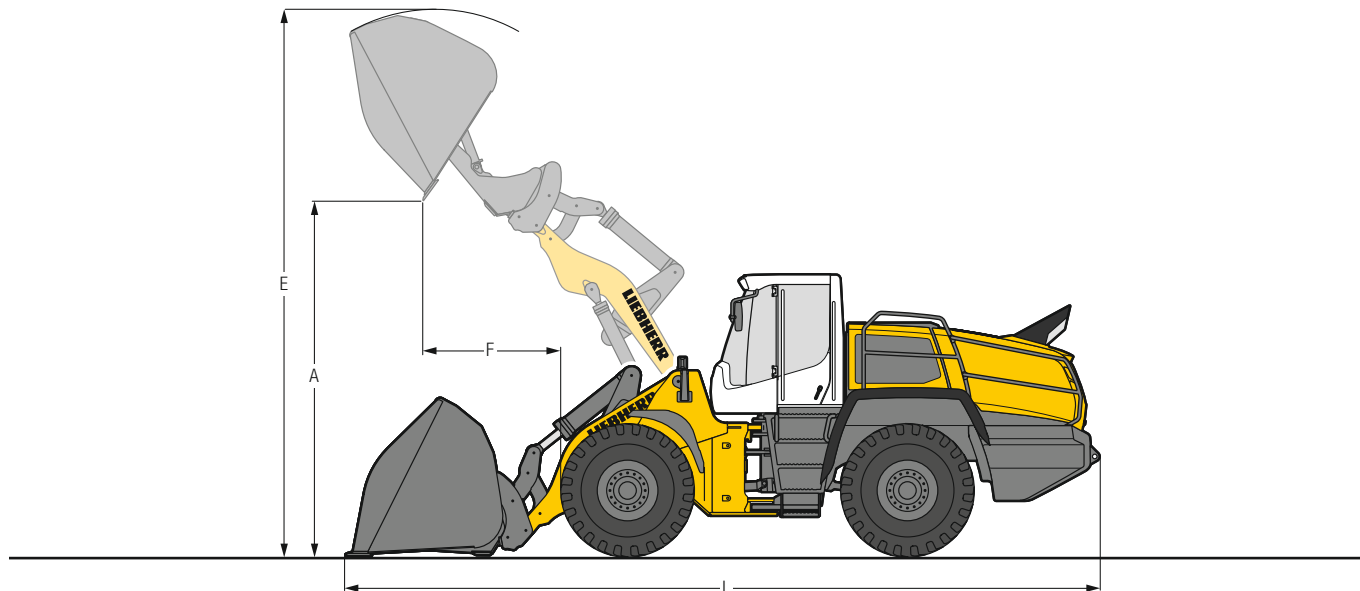

Heavy material density

	L 550		L 556	
	STD	HL	STD	HL
Geometry	IND-QH	IND-QH	IND-QH	IND-QH
Cutting tools	BOCE	BOCE	BOCE	BOCE
Bucket capacity	m ³ 4.5	4.0	5.0	4.5
Specific material density	t/m ³ 1.0	1.0	1.0	1.0
Bucket width	mm 2,700	2,700	2,700	2,700
A Dumping height at max. lift height	mm 4,645	5,235	4,570	5,190
E Max. operating height	mm 6,865	7,360	6,920	7,400
F Reach at maximum lift height	mm 1,685	1,400	1,750	1,445
L Overall length	mm 9,250	9,545	9,350	9,610
Tipping load, straight*	kg 11,900	10,100	13,600	11,300
Tipping load, fully articulated*	kg 10,300	8,700	11,800	9,600
Operating weight*	kg 19,900	20,000	20,400	21,000
Tyre size	23.5R25 L3		23.5R25 L3	



Light material density

	L 550		L 556	
	STD	HL	STD	HL
Geometry	IND-QH	IND-QH	IND-QH	IND-QH
Cutting tools	BOCE	BOCE	BOCE	BOCE
Bucket capacity	m ³ 9.0	8.0	9.5	8.5
Specific material density	t/m ³ 0.5	0.5	0.5	0.5
Bucket width	mm 3,400	3,400	3,400	3,400
A Dumping height at max. lift height	mm 4,335	4,955	4,290	4,895
E Max. operating height	mm 7,090	7,505	7,135	7,560
F Reach at maximum lift height	mm 1,720	1,420	1,760	1,470
L Overall length	mm 9,410	9,670	9,470	9,750
Tipping load, straight*	kg 11,400	9,700	12,800	10,900
Tipping load, fully articulated*	kg 9,800	8,300	11,000	9,300
Operating weight*	kg 20,500	20,600	21,500	21,600
Tyre size	23.5R25 L3		23.5R25 L3	

* The figures shown include the above tyres, all lubricants, a full fuel tank, the ROPS / FOPS cab and the operator. Different tyres and optional equipment will change the operating weight and tipping load. (Tipping load, fully articulated according to ISO 14397-1)

For wheel loaders with large light material buckets and high-dump buckets or log grapples, we supply visual aids such as mirrors or cameras for front area monitoring that meet the requirements of the ISO 5006:2017 field of vision test.

- STD = Standard lift arm length
- HL = High Lift
- IND-QH = Industrial lift arm with parallel guidance incl. quick hitch
- BOCE = Bolt-on cutting edge

Attachment

Fork carrier and fork

L 550 – L 556

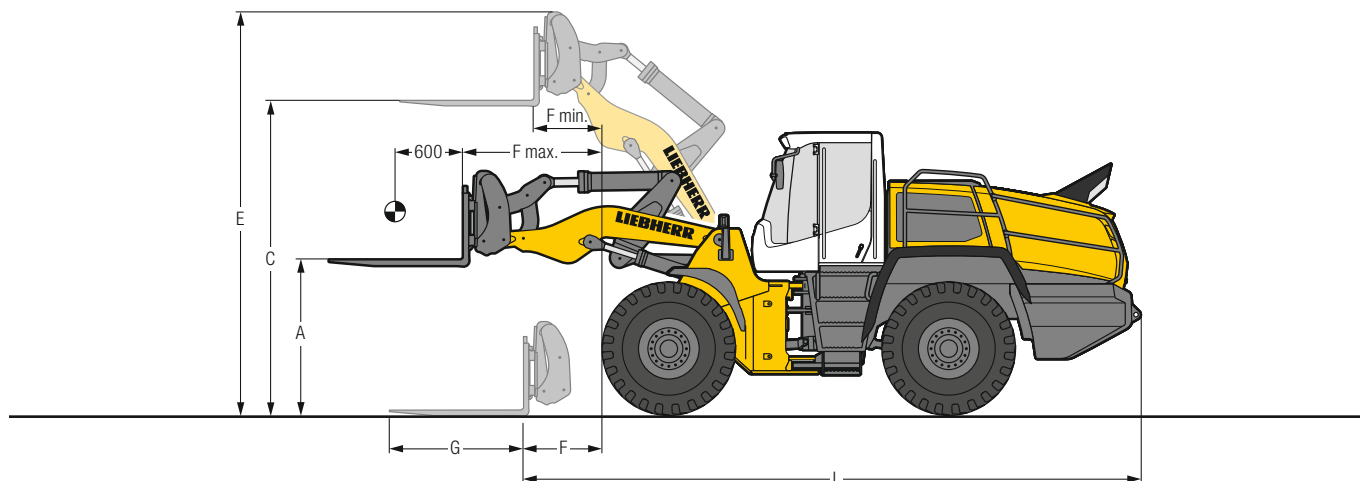

FEM IV fork carrier and fork

		L 550	L 556
Geometry		IND-QH	IND-QH
A	Lifting height at max. reach	mm	1,805
C	Max. lifting height	mm	3,905
E	Max. operating height	mm	4,895
F	Reach at loading position	mm	1,080
F max.	Max. reach	mm	1,710
F min.	Reach at max. lifting height	mm	715
G	Fork length	mm	1,500
L	Length – basic machine	mm	7,570
	Tipping load, straight*	kg	10,940
	Tipping load, fully articulated*	kg	9,630
	Recommended payload for uneven ground = 60% of tipping load, articulated ¹⁾	kg	5,780
	Recommended payload for smooth surfaces = 80% of tipping load, articulated ¹⁾	kg	7,710
	Operating weight*	kg	18,500
	Tyre size	23.5R25 L3	23.5R25 L3

* The figures shown include the above tyres, all lubricants, a full fuel tank, the ROPS / FOPS cab and the operator. Different tyres and optional equipment will change the operating weight and tipping load. (Tipping load, fully articulated according to ISO 14397-1)

¹⁾ According to EN 474-3

IND-QH = Industrial lift arm with parallel guidance incl. quick hitch

Attachment

Log grapple

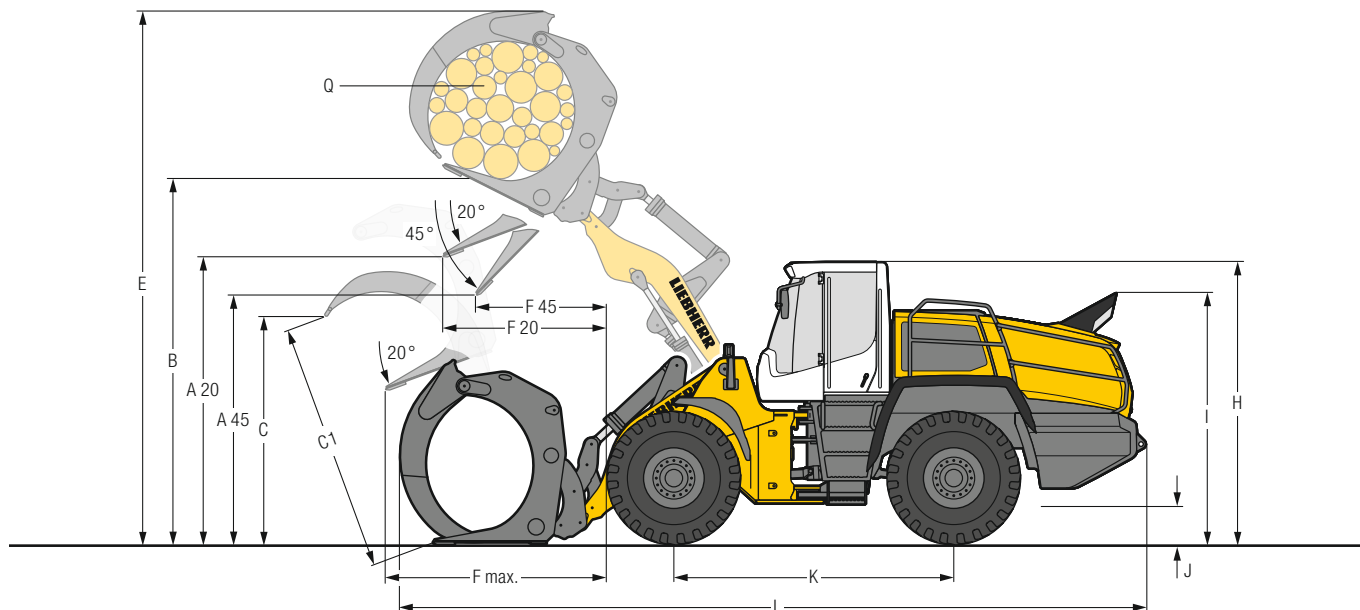

Log grapple

Geometry		L 550		L 556	
		IND-QH	IND-QH	IND-QH	
A20	Discharge height at 20°	mm	3,420	3,350	3,350
A45	Discharge height at 45°	mm	2,940	2,770	2,770
B	Manipulation height	mm	4,550	4,550	4,655
C	Max. grapple opening in loading position	mm	2,395	2,740	2,740
C1	Max. grapple opening	mm	2,590	2,990	2,990
E	Max. height	mm	6,350	6,650	6,650
F20	Reach at max. lifting height at 20° discharge	mm	1,590	1,810	1,810
F45	Reach at max. lifting height at 45° discharge	mm	1,160	1,330	1,330
F max.	Max. reach	mm	2,590	2,810	2,810
H	Height above operator's cab	mm	3,395	3,395	3,395
I	Height above exhaust	mm	3,045	3,045	3,045
J	Ground clearance	mm	490	490	490
K	Wheelbase	mm	3,500	3,500	3,500
L	Overall length	mm	8,800	9,080	9,080
Width over tyres		mm	2,650	2,650	2,650
Q	Grapple diameter	m ²	1.8	2.4	2.4
Grapple width		mm	1,600	1,600	1,600
Payload*		kg	6,300	6,000	6,400
Operating weight*		kg	20,000	20,150	21,000
Tyre size			23.5R25 L4		23.5R25 L4

* The figures shown include the above tyres, all lubricants, a full fuel tank, the ROPS / FOPS cab and the operator. Different tyres and optional equipment will change the operating weight and payload.

For wheel loaders with large light material buckets and high-dump buckets or log grapples, we supply visual aids such as mirrors or cameras for front area monitoring that meet the requirements of the ISO 5006:2017 field of vision test.

IND-QH = Industrial lift arm with parallel guidance incl. quick hitch

Bucket selection

L 550 – L 556

L 550

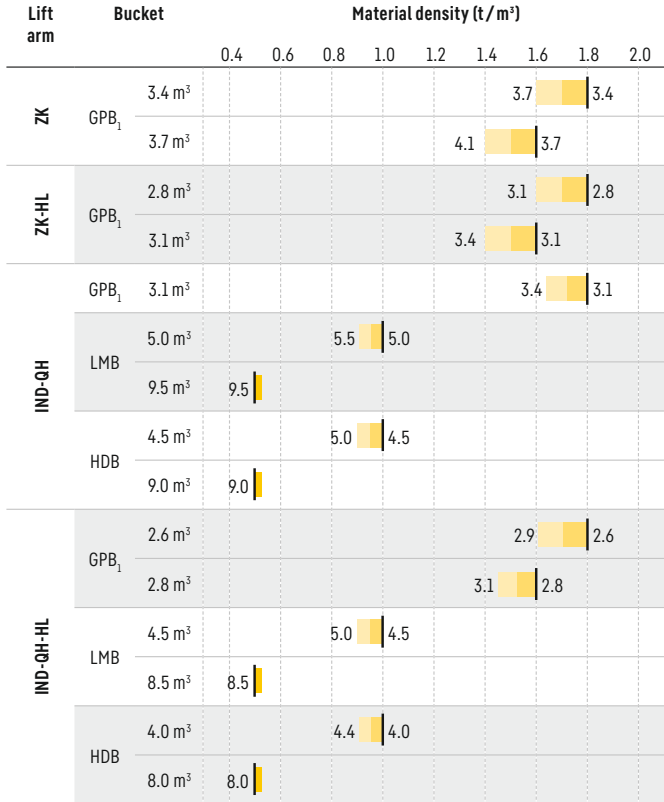

L 556

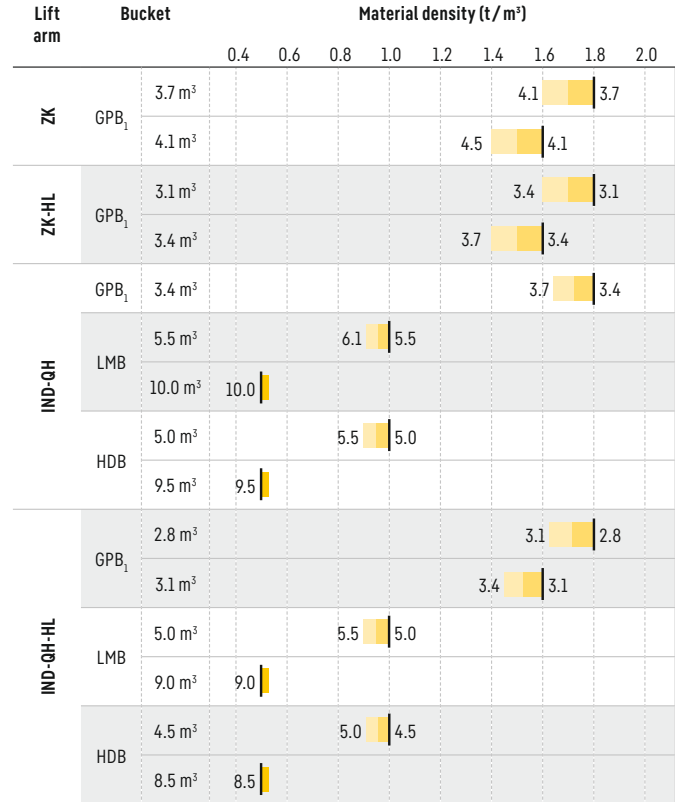

Bucket filling factor

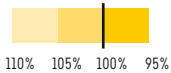

Lift arm

ZK	Z-bar kinematics, standard lift arm length
ZK-HL	Z-bar kinematics, High Lift
IND-QH	Industrial lift arm with quick hitch, standard lift arm length
IND-QH-HL	Industrial lift arm with quick hitch, High Lift

Bucket

GPB ₁	General purpose bucket (Excavation bucket)
LMB	Light material bucket
HDB	High-dump bucket

For wheel loaders with large light material buckets and high-dump buckets or log grapples, we supply visual aids such as mirrors or cameras for front area monitoring that meet the requirements of the ISO 5006:2017 field of vision test.

Bulk material densities and bucket filling factors

		t/m³	%			t/m³	%			t/m³	%
Gravel	moist	1.9	105	Earth	dry	1.3	115	Glass waste	broken	1.4	100
	dry	1.6	105		wet excavated	1.6	110		solid	1.0	100
	crushed stone	1.5	100	Topsoil		1.1	110		Compost	dry	0.8
Sand	dry	1.5	105	Basalt		1.95	100	wet	1.0	110	
	wet	1.9	110	Granite		1.8	95	Wood chips / Saw dust		0.5	110
Gravel and Sand	dry	1.7	105	Sandstone		1.6	100	Paper	shredded / loose	0.6	110
	wet	2.0	100	Slate		1.75	100	recovered paper / cardboard		1.0	110
Sand / Clay		1.6	110	Bauxite		1.4	100	Coal	heavy material density	1.2	110
Clay	natural	1.6	110	Limestone		1.6	100	light material density		0.9	110
	dry	1.4	110	Gypsum	broken	1.8	100	Waste	domestic waste	0.5	100
Clay / Gravel	dry	1.4	110	Coke		0.5	110	bulky waste		1.0	100
	wet	1.6	100	Slag	broken	1.8	100				

Tyres



Tyre types

	Size and tread code	Change of operating weight kg	Width over tyres mm	Change in vertical dimensions* mm	Use
L 550 XPower / L 556 XPower					
Bridgestone	23.5R25 VJT L3	138	2,670	6	Bulk material (firm ground conditions)
Bridgestone	23.5R25 VLTS L4	360	2,670	39	Gravel, Industry (firm ground conditions)
Bridgestone	23.5R25 VSDL L5	898	2,660	65	Stone, Scrap, Recycling (firm ground conditions)
Bridgestone	23.5R25 VSDT L5	851	2,670	55	Stone, Scrap, Recycling (firm ground conditions)
Bridgestone	750/65R25 VTS L3	728	2,880	11	Gravel, Industry, Wood (all ground conditions)
Continental	23.5R25 EM-Master L3	212	2,670	29	Bulk material (firm ground conditions)
Continental	23.5R25 EM-Master L4	332	2,660	20	Gravel, Industry, Wood (firm ground conditions)
Goodyear	23.5R25 TL-3A+ L3	284	2,670	36	Sand, Gravel, Earthworks, Clay (all ground conditions)
Goodyear	23.5R25 GP-4D L4	328	2,690	25	Gravel, Industry, Wood (firm ground conditions)
Goodyear	23.5R25 RL-4K L4	500	2,680	39	Gravel, Industry, Stone (firm ground conditions)
Goodyear	23.5R25 RL-5K L5	936	2,680	57	Stone, Scrap, Recycling (firm ground conditions)
Goodyear	23.5R25 RL-5S L5	968	2,680	57	Scrap, Recycling, Slag (firm ground conditions)
Goodyear	23.5R25 RT-5D L5	820	2,660	55	Stone, Mining spoil (firm ground conditions)
Goodyear	750/65R25 TL-3A+ L3	680	2,910	24	Sand, Gravel, Industry, Wood (all ground conditions)
Michelin	23.5R25 XHA2 L3	0	2,650	0	Sand, Gravel (all ground conditions)
Michelin	23.5R25 XTLA L2	- 12	2,650	- 4	Gravel, Earthworks, Clay (all ground conditions)
Michelin	23.5R25 X MINE PRO L5	828	2,700	56	Stone, Scrap, Recycling (firm ground conditions)
Michelin	23.5R25 XLD D2A L5	612	2,670	26	Stone, Mining spoil (firm ground conditions)
Michelin	650/65R25 XLD65 L3T	- 112	2,690	- 53	Gravel, Industry, Wood (all ground conditions)
Michelin	750/65R25 XLD65 L3T	524	2,870	- 7	Gravel, Industry, Wood (all ground conditions)

* The stated values are theoretical and may deviate in practice.

Before operating the vehicle with tyre foam filling or tyre protection chains, please discuss this with the Liebherr-Werk Bischofshofen GmbH.

Technical data

L 566 – L 586

Diesel engine

	L 566	L 576	L 580	L 586
Diesel engine	D936 A7	D936 A7	D936 A7	D936 A7
Design	Water-cooled in-series engine with charge-air cooling			
Cylinder inline	6	6	6	6
Fuel injection process	Electronic Common Rail high-pressure injection			
Output to	200 / 272	215 / 292	230 / 313	260 / 354
ISO 9249 / ECE-R.24	1,800	1,800	1,800	1,800
at RPM				
Rated output to				
ISO 14396 / ECE-R.120	203 / 276	218 / 296	233 / 317	263 / 358
at RPM	1,800	1,800	1,800	1,800
Nominal speed	1,800	1,800	1,800	1,800
Max. torque to ISO	1,914	1,969	1,969	1,969
14396 / ECE-R.120	1,000	1,000	1,000	1,000
at RPM				
Displacement	10.52	10.52	10.52	10.52
litres				
Bore / Stroke	122 / 150	122 / 150	122 / 150	122 / 150
mm				
Stage IV – available only in select markets				
Harmful emissions values	According to regulation ECE-R.96 Power Band Q			
Emission control	litres Liebherr-SCR technology			
Stage V				
Harmful emissions values	According to regulation (EU) 2016/1628			
Emission control	Liebherr-SCR technology and closed diesel particle filter system			
Air cleaner system	Dry type filter with main and safety element, pre-cleaner, service indicator on the Liebherr display			
Electrical system				
Operating voltage	V 24	24	24	24
Capacity	Ah 2 x 180	2 x 180	2 x 180	2 x 180
Alternator	V/A 28 / 180	28 / 180	28 / 180	28 / 180
Starter	V/kW 24 / 7.8	24 / 7.8	24 / 7.8	24 / 7.8

Driveline

Continuous power split XPower driveline

Design	Continuous, fully-automatic XPower driveline. No traction interruptions across the entire speed range. Hydrostatic power split with two axial piston units. Identical driving performance – forwards and in reverse
Filtration	Filter system for driveline, depend on working hydraulics
Control	Driveline is controlled from travel pedal for tractive force and speed setting with integrated inch function. The Liebherr control lever is used to control forward and reverse travel
Travel speed range	L 566 – L 580: 0 – 40 km/h forward and reverse, fully-automatic. L 586: 0 – 33 km/h forward and reverse, fully-automatic. Speed restriction available upon request. Speeds quoted apply with the tyres indicated as standard on loader model.

Brakes

Wear-free service brake	Self-locking of the XPower driveline (acting on all four wheels) and additional pump-accumulator brake system with wet multi-disc brakes (two separate brake circuits)
Parking brake	Electro-hydraulically actuated spring-loaded disc brake system on the transmission

The braking system meets the requirements of the ISO 3450.

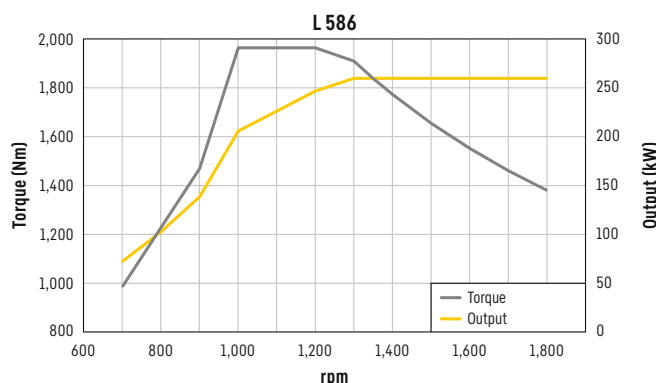
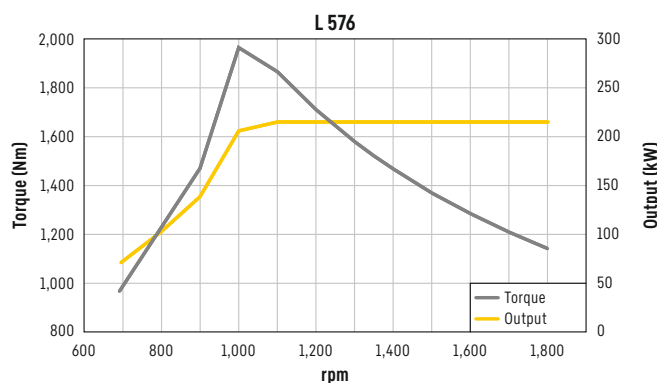
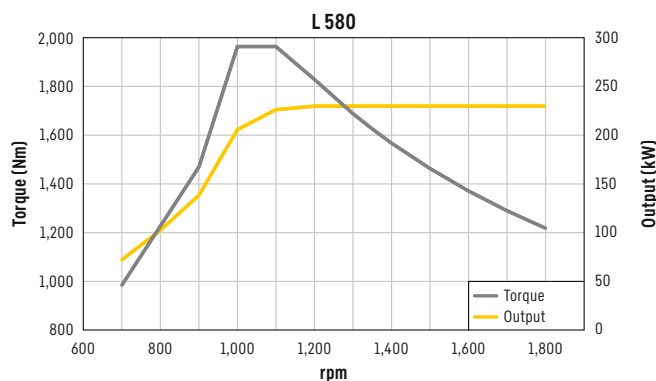
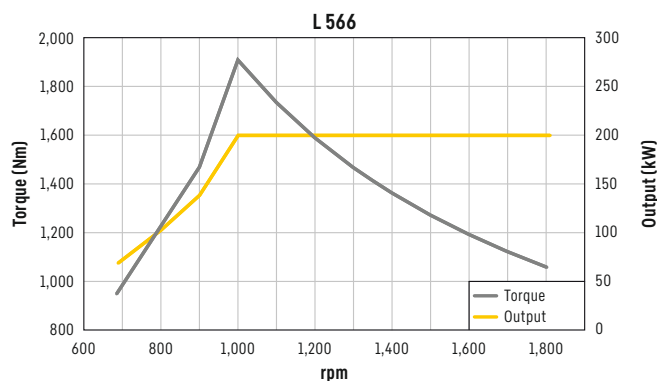

Axles

	L 566	L 576	L 580	L 586	
Four-wheel drive					
Front axle	Fixed				
Rear axle	Centre pivot, with 13° oscillating angle to each side				
Height of obstacles which can be driven over	mm	492	473	473	523
		with all four wheels remaining in contact with the ground			
Differentials	Automatic limited-slip differentials				
Reduction gear	Planetary final drive in wheel hubs				
Track width	2,230 mm with all types of tyres (L 566, L 576, L 580) 2,440 mm with all types of tyres (L 586)				

Steering

Design	“Load-sensing” swash plate type variable flow pump with pressure cut-off and flow control. Central pivot with two double-acting, damped steering cylinders
Angle of articulation	38° to each side (L 566, L 576, L 580) 37° to each side (L 586)
Emergency steering	Electro-hydraulic emergency steering system

Attachment hydraulics

	L 566	L 576	L 580	L 586	
Design	“Load-sensing” swash plate type variable flow pump with output and flow control, and pressure cut-off in the control block				
Cooling	Hydraulic oil cooling using thermostatically controlled fan and oil cooler				
Filtration	Return line filter in the hydraulic reservoir				
Control	Liebherr control lever, electro-hydraulically operated				
Lifting function	Lifting, neutral, lowering Automatic lift arm position and lowering by Liebherr control lever Float position controlled by Liebherr control lever				
Tilt function	Tilt back, neutral, dump Automatic bucket return for tilting back and dumping controlled by Liebherr control lever				
Max. flow	l/min.	290	290	320	410
Max. pressure					
Z-bar kinematics	bar	350	380	380	350
Industrial lift arm	bar	380	380		

Attachment

	L 566	L 576	L 580	L 586			
Geometry variants							
Optional	Powerful Z-bar kinematics with tilt cylinder and cast steel cross-tube Industrial lift arm with tilt cylinder, hydraulic quick hitch as standard (L 566, L 580)						
Bearings	Sealed						
Cycle time at nominal load	ZK	IND	ZK	ZK	IND	ZK	
Lifting	s	6.1	6.1	6.1	6.2	6.2	6.4
Dumping	s	1.2	2.0	1.2	1.4	2.2	1.5
Lowering (empty)	s	3.2	3.2	3.2	3.4	3.4	3.6

Operator's cab

Design	Hydraulically mounted, noise-proof cab ROPS roll over protection per EN ISO 3471 / EN 474-1 FOPS falling objects protection per EN ISO 3449 / EN 474-1, Cat. II Operator's door with sliding side window, sliding side window on right, front windscreen made of compound safety glass, side panels with single-pane safety glass ESG, heated rear window ESG, all windows are tinted. 3 way continuous adjustable steering column
Liebherr operator's seat	6 way adjustable, vibration-damped operator's seat “Comfort” with seat, depth and incline adjustment as standard (air-cushioned with seat heating adjustable to operator's weight), Liebherr control lever mounted into the operator's seat as standard
Cab heating and ventilation	4-zone air conditioning with new improved cooling output as standard, electrically heated rear window, all filters are easy to access and replaceable
Vibration emissions	
Hand / arm vibrations	≤ 2.5 m/s ² , according with ISO 5349-1:2001
Whole-body vibrations	≤ 0.5 m/s ² , complies with technical report ISO/TR 25398:2006
Measuring inaccuracy	According with standard EN 12096:1997

Sound level

	L 566	L 576	L 580	L 586	
Sound pressure level to ISO 6396					
L _{PA} (inside cab)	dB(A)	68	68	68	68
Sound power level to 2000/14/EC					
L _{WA} (surround noise)	dB(A)	105	105	105	107

Füllmengen

	L 566	L 576	L 580	L 586	
Fuel tank	l	365	365	365	500
DEF tank	l	67.5	67.5	67.5	67.5
Engine oil (inclusive filter change)	l	42	42	42	42
Pump distribution gearbox	l	1.2	1.2	1.2	1.2
XPower gearbox	l	55	55	55	55
Coolant	l	73	73	73	73
Front axle	l	42	58	58	60
Rear axle	l	42	42	58	60
Hydraulic tank	l	105	105	105	95
Hydraulic system, total	l	190	190	190	210
Air conditioning system R134a	g	1,250	1,250	1,250	1,250

Dimensions

Z-bar kinematics

L 566 – L 586

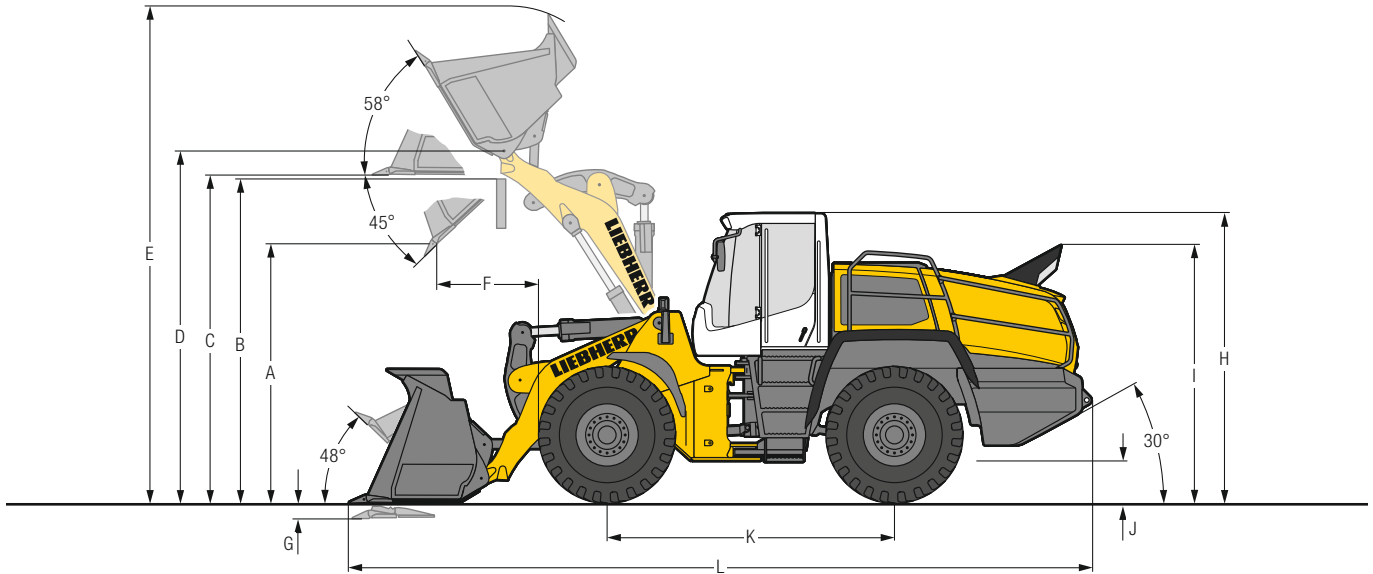

Loading bucket

	L 566		L 576		L 580			L 586		
Geometry	ZK	ZK	ZK	ZK	ZK	ZK	ZK	ZK	ZK	ZK
Cutting tools	T	T	T	T	T	T	BOCE	T	T	ROB
Lift arm length	mm	2,920	2,920	3,050	3,050	3,050	3,050	3,150	3,150	3,150
Bucket		GPB ₁	GPB ₁	GPB ₁	GPB ₁	GPB ₁	GPB ₂	GPB ₂	GPB ₂	RB
Bucket capacity according to ISO 7546**	m ³	4.2	4.7	4.7	5.2	5.2	5.7 ¹⁾	6.0	6.5	5.5
Specific material density	t/m ³	1.8	1.6	1.8	1.6	1.8	1.6	1.7	1.8	1.6
Bucket width	mm	3,000	3,000	3,000	3,000	3,000	3,300	3,430	3,650	3,400
A Dumping height at max. lift height and 45° discharge	mm	3,205	3,130	3,355	3,285	3,285	3,220	3,260	3,260	3,290
B Dump-over height	mm	3,900	3,900	4,100	4,100	4,100	4,100	4,150	4,150	4,150
C Max. height of bucket bottom	mm	4,050	4,050	4,270	4,270	4,270	4,270	4,330	4,330	4,300
D Max. height of bucket pivot point	mm	4,360	4,360	4,580	4,580	4,580	4,580	4,640	4,640	4,660
E Max. operating height	mm	6,120	6,220	6,440	6,540	6,540	6,500	6,530	6,530	6,450
F Reach at max. lift height and 45° discharge	mm	1,190	1,270	1,135	1,205	1,205	1,285	1,285	1,430	1,430
G Digging depth	mm	100	100	100	100	100	100	100	100	140
H Height above operator's cab	mm	3,590	3,590	3,590	3,590	3,590	3,590	3,740	3,740	3,760
I Height above exhaust	mm	3,200	3,200	3,200	3,200	3,200	3,200	3,300	3,300	3,320
J Ground clearance	mm	535	535	540	540	465	465	465	575	575
K Wheelbase	mm	3,560	3,560	3,630	3,630	3,710	3,710	3,710	3,900	3,900
L Overall length	mm	9,165	9,275	9,445	9,545	9,620	9,720	9,720	9,980	9,980
Turning circle radius over tyres	mm	6,690	6,690	6,780	6,780	6,885	6,885	6,885	7,485	7,485
Turning circle radius over outside bucket edge	mm	7,340	7,370	7,500	7,530	7,615	7,780	7,780	8,350	8,400
Breakout force (SAE)	kN	200	190	200	190	225	205	200	240	245
Tipping load, straight*	kg	18,150	17,900	20,100	19,900	21,750	21,250	22,200	24,500	23,900
Tipping load, fully articulated*	kg	15,900	15,650	17,600	17,400	19,200	18,700	19,500	21,600	21,000
Operating weight*	kg	23,900	24,000	25,700	25,800	27,650	27,800	28,800	32,600	33,050
Tyre size		26.5R25 L3		26.5R25 L3		26.5R25 L3			29.5R25 L3	

* The figures shown include the above tyres, all lubricants, a full fuel tank, the ROPS / FOPS cab and the operator. Different tyres and optional equipment will change the operating weight and tipping load. (Tipping load, fully articulated according to ISO 14397-1)

** Actual bucket capacity may be approx. 10% larger than the calculation according to ISO 7546 standard. The degree to which the bucket can be filled depends on the material – see pages 34 / 35.

¹⁾ Toothed buckets, hydraulic quick hitch and additional hydraulic circuits are not approved for rehandling application.

GPB₁ = Excavation bucket with back grading edge for direct mounting

GPB₂ = Rehandling bucket for direct mounting

RB = Rock bucket with oblique base for quarrying applications for direct mounting

ZK = Z-bar kinematics

T = Welded-on tooth holder with add-on teeth

BOCE = Bolt-on cutting edge

ROB = Rock bucket with delta cutting edge, welded-on tooth holder with add-on teeth and bolted intermediate sections

Dimensions

Z-bar kinematics high lift

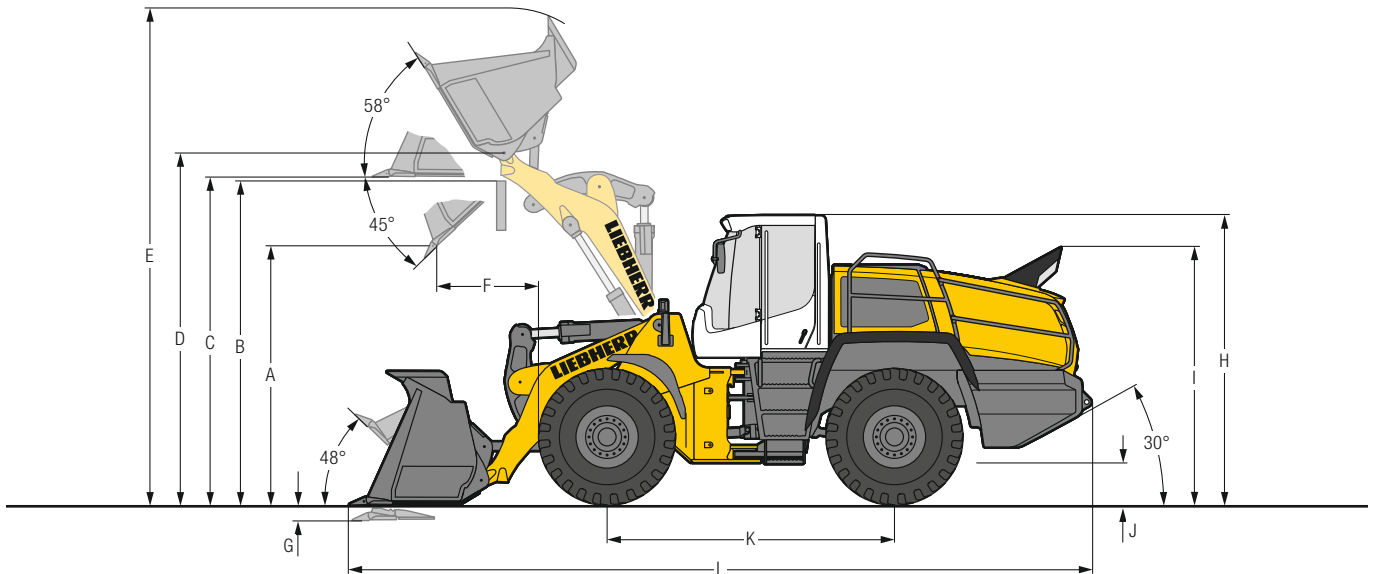

L 566 - L 586



Loading bucket

	L 566		L 576		L 580			L 586			
	ZK	ZK	ZK	ZK	ZK	ZK	ZK	ZK	ZK	ZK	
Geometry											
Cutting tools	T	T	T	T	T	T	BOCE	T	T	ROB	
Lift arm length	mm	3,250	3,250	3,250	3,250	3,250	3,250	3,450	3,450	3,450	
Bucket		GPB ₁	GPB ₁	GPB ₁	GPB ₁	GPB ₁	GPB ₂	GPB ₂	GPB ₂	RB	
Bucket capacity according to ISO 7546**	m ³	3.7	4.2	4.2	4.7	4.7	5.2 ¹⁾	5.2 ¹⁾	5.5	6.0	5.0
Specific material density	t/m ³	1.8	1.6	1.8	1.6	1.8	1.6	1.7	1.8	1.6	1.8
Bucket width	mm	3,000	3,000	3,000	3,000	3,000	3,000	3,000	3,400	3,400	3,400
A Dumping height at max. lift height and 45° discharge	mm	3,720	3,650	3,650	3,575	3,560	3,490	3,425	3,725	3,670	3,745
B Dump-over height	mm	4,300	4,300	4,300	4,300	4,300	4,300	4,300	4,500	4,500	4,500
C Max. height of bucket bottom	mm	4,470	4,470	4,470	4,470	4,470	4,470	4,470	4,750	4,750	4,770
D Max. height of bucket pivot point	mm	4,780	4,780	4,780	4,780	4,780	4,780	4,780	5,060	5,060	5,080
E Max. operating height	mm	6,460	6,555	6,555	6,650	6,650	6,740	6,700	6,950	6,980	6,800
F Reach at max. lift height and 45° discharge	mm	1,130	1,200	1,130	1,215	1,190	1,265	1,340	1,370	1,410	1,370
G Digging depth	mm	140	140	140	140	140	140	140	100	100	140
H Height above operator's cab	mm	3,590	3,590	3,590	3,590	3,590	3,590	3,590	3,740	3,740	3,760
I Height above exhaust	mm	3,200	3,200	3,200	3,200	3,200	3,200	3,200	3,300	3,300	3,320
J Ground clearance	mm	535	535	540	540	465	465	465	575	575	575
K Wheelbase	mm	3,560	3,560	3,630	3,630	3,710	3,710	3,710	3,900	3,900	3,900
L Overall length	mm	9,500	9,590	9,590	9,700	9,770	9,870	9,970	10,250	10,280	10,300
Turning circle radius over tyres	mm	6,690	6,690	6,780	6,780	6,885	6,885	6,885	7,485	7,485	7,545
Turning circle radius over outside bucket edge	mm	7,480	7,510	7,560	7,590	7,680	7,710	7,740	8,500	8,550	8,450
Breakout force (SAE)	kN	210	200	210	200	240	225	225	250	240	260
Tipping load, straight*	kg	15,850	15,650	18,650	18,550	20,200	20,000	20,600	22,400	21,700	22,700
Tipping load, fully articulated*	kg	13,850	13,650	16,350	16,250	17,800	17,600	18,200	19,700	19,000	20,000
Operating weight*	kg	24,000	24,100	25,650	25,750	27,650	27,750	28,600	32,600	33,000	33,900
Tyre size		26.5R25 L3		26.5R25 L3		26.5R25 L3			29.5R25 L3		29.5R25 L5

* The figures shown include the above tyres, all lubricants, a full fuel tank, the ROPS/FOPS cab and the operator. Different tyres and optional equipment will change the operating weight and tipping load. (Tipping load, fully articulated according to ISO 14397-1)

** Actual bucket capacity may be approx. 10% larger than the calculation according to ISO 7546 standard. The degree to which the bucket can be filled depends on the material - see pages 34 / 35.

¹⁾ Toothed buckets, hydraulic quick hitch and additional hydraulic circuits are not approved for rehandling application.

GPB₁ = Excavation bucket with back grading edge for direct mounting

GPB₂ = Rehandling bucket for direct mounting

RB = Rock bucket with oblique base for quarrying applications for direct mounting

ZK = Z-bar kinematics

T = Welded-on tooth holder with add-on teeth

BOCE = Bolt-on cutting edge

ROB = Rock bucket with delta cutting edge, welded-on tooth holder with add-on teeth and bolted intermediate sections

Dimensions

Industrial lift arm

L 566 – L 586

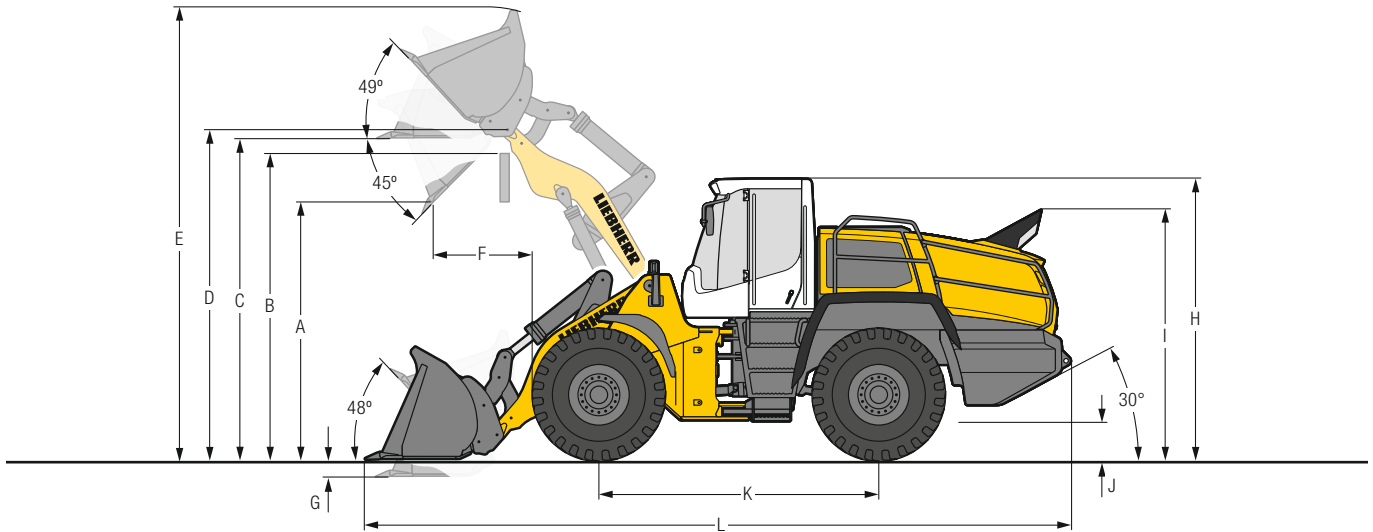

Excavation bucket

	L 566		L 580	
	IND-QH	IND-QH	IND-QH	IND-QH
Geometry				
Cutting tools	T	T	T	T
Lift arm length	mm 2,900	2,900	2,900	2,900
Bucket capacity according to ISO 7546**	m ³ 3.5	4.0	4.5	5.0
Specific material density	t/m ³ 1.8	1.6	1.8	1.6
Bucket width	mm 3,000	3,000	3,000	3,000
A Dumping height at max. lift height and 45° discharge	mm 3,210	3,140	3,070	3,000
B Dump-over height	mm 3,900	3,900	3,900	3,900
C Max. height of bucket bottom	mm 4,145	4,145	4,145	4,145
D Max. height of bucket pivot point	mm 4,490	4,490	4,490	4,490
E Max. operating height	mm 6,045	6,165	6,265	6,330
F Reach at max. lift height and 45° discharge	mm 1,270	1,340	1,290	1,230
G Digging depth	mm 100	100	100	100
H Height above operator's cab	mm 3,590	3,590	3,590	3,590
I Height above exhaust	mm 3,200	3,200	3,200	3,200
J Ground clearance	mm 535	535	465	465
K Wheelbase	mm 3,630	3,630	3,710	3,710
L Overall length	mm 9,270	9,370	9,545	9,650
Turning circle radius over tyres	mm 6,780	6,780	6,885	6,885
Turning circle radius over outside bucket edge	mm 7,410	7,440	7,560	7,590
Breakout force (SAE)	kN 200	185	200	185
Tipping load, straight*	kg 17,100	16,650	20,150	19,700
Tipping load, fully articulated*	kg 15,000	14,550	17,750	17,300
Operating weight*	kg 24,800	24,950	28,050	28,200
Tyre size	26.5R25 L3		26.5R25 L3	

* The figures shown include the above tyres, all lubricants, a full fuel tank, the ROPS/FOPS cab and the operator. Different tyres and optional equipment will change the operating weight and tipping load. (Tipping load, fully articulated according to ISO 14397-1)

** Actual bucket capacity may be approx. 10% larger than the calculation according to ISO 7546 standard. The degree to which the bucket can be filled depends on the material – see pages 34/35.

IND-QH = Industrial lift arm with parallel guidance incl. quick hitch

T = Welded-on tooth holder with add-on teeth

Attachment

Light material bucket and High-Dump bucket

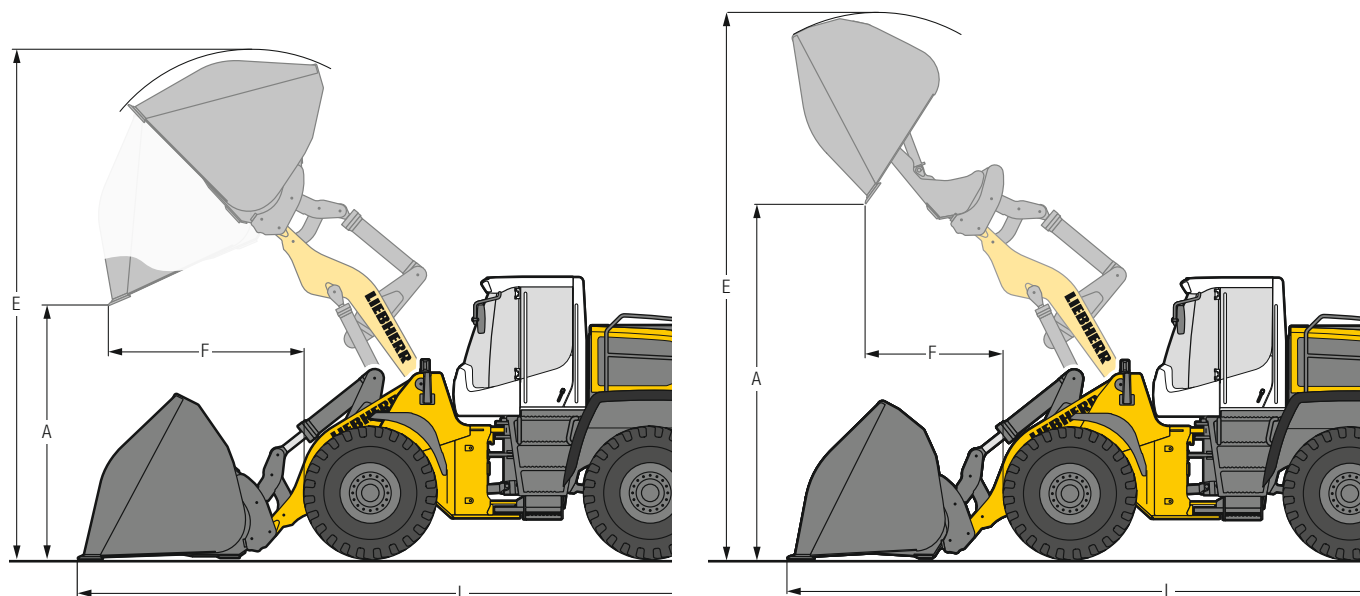

L 566 - L 586



Light material bucket

	L 566		L 580		L 586
	IND-QH	IND-QH	IND-QH	IND-QH	ZK
Geometry	IND-QH	IND-QH	IND-QH	IND-QH	ZK
Cutting tools	BOCE	BOCE	BOCE	BOCE	BOCE
Bucket capacity	6.5 m ³	12.0 m ³	7.5 m ³	14.0 m ³	8.5 m ³
Specific material density	1.0 t/m ³	0.45 t/m ³	1.0 t/m ³	0.45 t/m ³	1.1 t/m ³
Bucket width	3,200 mm	3,700 mm	3,400 mm	4,000 mm	3,500 mm
A Dumping height at max. lift height	2,885 mm	2,620 mm	2,810 mm	2,480 mm	2,940 mm
E Max. operating height	6,470 mm	6,700 mm	6,580 mm	6,800 mm	6,835 mm
F Reach at maximum lift height	1,485 mm	1,860 mm	1,550 mm	1,950 mm	1,770 mm
L Overall length	9,545 mm	10,025 mm	9,715 mm	10,200 mm	10,200 mm
Tipping load, straight*	15,700 kg	14,600 kg	19,300 kg	17,900 kg	24,000 kg
Tipping load, fully articulated*	13,700 kg	12,600 kg	16,900 kg	15,500 kg	21,000 kg
Operating weight*	25,350 kg	26,300 kg	28,650 kg	29,600 kg	32,800 kg
Tyre size	26.5R25 L3		26.5R25 L3		29.5R25 L3



High-Dump bucket

	L 566		L 580		L 586
	IND-QH	IND-QH	IND-QH	IND-QH	ZK
Geometry	IND-QH	IND-QH	IND-QH	IND-QH	ZK
Cutting tools	BOCE	BOCE	BOCE	BOCE	BOCE
Bucket capacity	6.0 m ³	11.0 m ³	7.0 m ³	13.0 m ³	8.5 m ³
Specific material density	1.0 t/m ³	0.45 t/m ³	1.0 t/m ³	0.45 t/m ³	1.0 t/m ³
Bucket width	3,200 mm	3,700 mm	3,200 mm	4,000 mm	3,500 mm
A Dumping height at max. lift height	5,130 mm	4,840 mm	4,970 mm	4,780 mm	5,100 mm
E Max. operating height	7,215 mm	7,490 mm	7,420 mm	7,650 mm	7,700 mm
F Reach at maximum lift height	1,780 mm	2,140 mm	2,040 mm	2,060 mm	2,000 mm
L Overall length	9,815 mm	10,125 mm	10,060 mm	10,300 mm	10,500 mm
Tipping load, straight*	14,700 kg	14,100 kg	17,800 kg	17,100 kg	23,200 kg
Tipping load, fully articulated*	12,700 kg	12,100 kg	15,500 kg	14,800 kg	20,300 kg
Operating weight*	26,000 kg	26,900 kg	29,100 kg	30,100 kg	33,500 kg
Tyre size	26.5R25 L3		26.5R25 L3		29.5R25 L3

* The figures shown include the above tyres, all lubricants, a full fuel tank, the ROPS / FOPS cab and the operator. Different tyres and optional equipment will change the operating weight and tipping load. (Tipping load, fully articulated according to ISO 14397-1)

For wheel loaders with large light material buckets and high-dump buckets or log grapples, we supply visual aids such as mirrors or cameras for front area monitoring that meet the requirements of the ISO 5006:2017 field of vision test.

IND-QH = Industrial lift arm with parallel guidance incl. quick hitch

ZK = Z-bar kinematics

BOCE = Bolt-on cutting edge

Attachment

Fork carrier and fork

L 566 – L 586

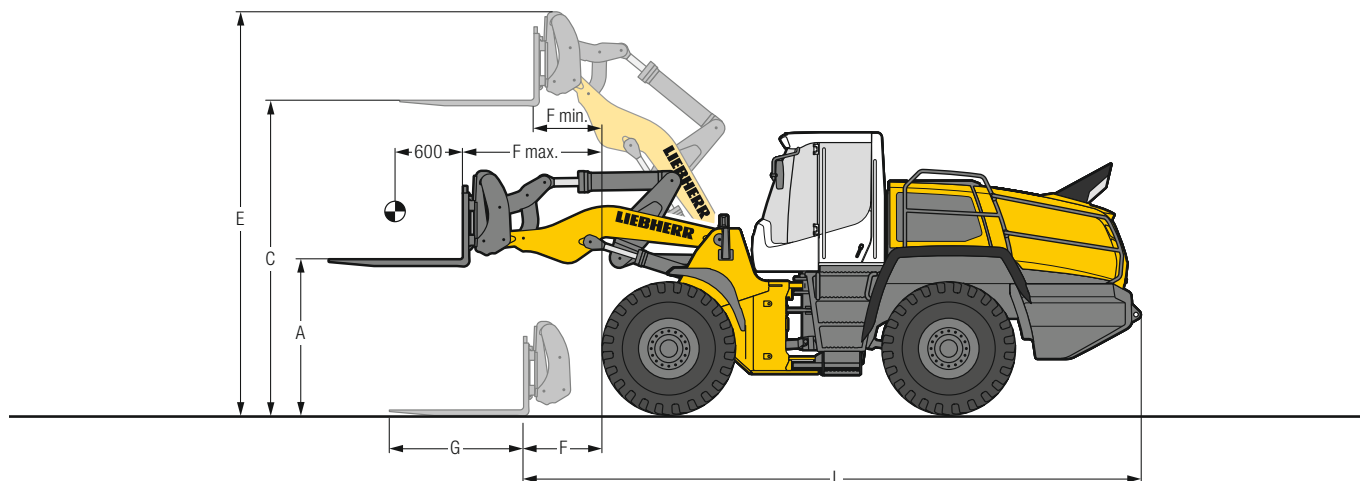

FEM IV fork carrier and fork

		L 566	L 580
Geometry		IND-QH	IND-QH
A	Lifting height at max. reach	mm	2,075
C	Max. lifting height	mm	4,220
E	Max. operating height	mm	5,200
F	Reach at loading position	mm	1,145
F max.	Max. reach	mm	1,805
F min.	Reach at max. lifting height	mm	980
G	Fork length	mm	1,800
L	Length - basic machine	mm	8,100
	Tipping load, straight*	kg	13,500
	Tipping load, fully articulated*	kg	11,900
	Recommended payload for uneven ground = 60% of tipping load, articulated ¹⁾	kg	7,140
	Recommended payload for smooth surfaces = 80% of tipping load, articulated ¹⁾	kg	9,520
	Operating weight*	kg	23,950
	Tyre size	26.5R25 L3	26.5R25 L3

* The figures shown include the above tyres, all lubricants, a full fuel tank, the ROPS / FOPS cab and the operator. Different tyres and optional equipment will change the operating weight and tipping load.
(Tipping load, fully articulated according to ISO 14397-1)

¹⁾ According to EN 474-3

²⁾ Payload is limited by FEM IV fork carrier and forks

IND-QH = Industrial lift arm with parallel guidance incl. quick hitch

Attachment

Log grapple

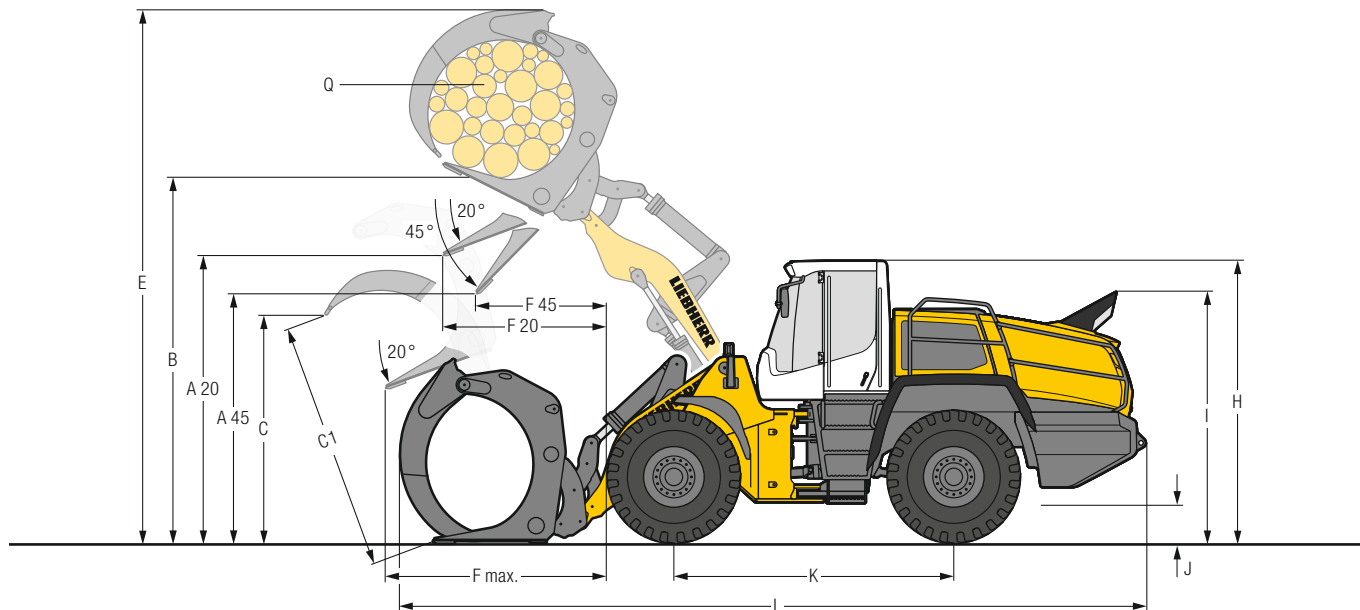

L 566 - L 586

Log grapple

		L 566	L 580
Geometry		IND-QH	IND-QH
A20	Discharge height at 20°	3,570	3,520
A45	Discharge height at 45°	2,930	2,805
B	Manipulation height	5,125	5,125
C	Max. grapple opening in loading position	2,650	2,930
C1	Max. grapple opening	3,050	3,340
E	Max. height	7,400	7,500
F20	Reach at max. lifting height at 20° discharge	2,165	2,215
F45	Reach at max. lifting height at 45° discharge	1,620	1,625
F max.	Max. reach	3,110	3,160
H	Height above operator's cab	3,615	3,615
I	Height above exhaust	3,225	3,225
J	Ground clearance	555	485
K	Wheelbase	3,630	3,710
L	Overall length	9,810	10,050
Width over tyres		2,970	2,970
Q	Grapple diameter	3.1	3.5
Grapple width		1,800	1,800
Payload*		8,200	9,200
Operating weight*		26,950	29,850
Tyre size		26.5R25 L4	26.5R25 L4

* The figures shown include the above tyres, all lubricants, a full fuel tank, the ROPS / FOPS cab and the operator. Different tyres and optional equipment will change the operating weight and payload.

For wheel loaders with large light material buckets and high-dump buckets or log grapples, we supply visual aids such as mirrors or cameras for front area monitoring that meet the requirements of the ISO 5006:2017 field of vision test.

IND-QH = Industrial lift arm with parallel guidance incl. quick hitch

Bucket selection

L 566 – L 586

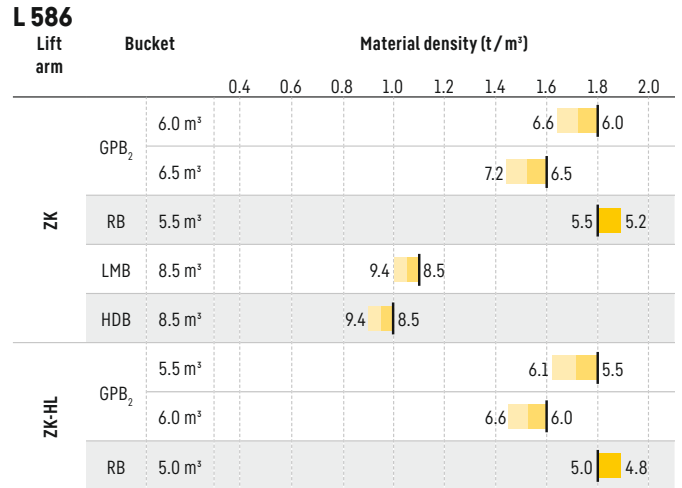
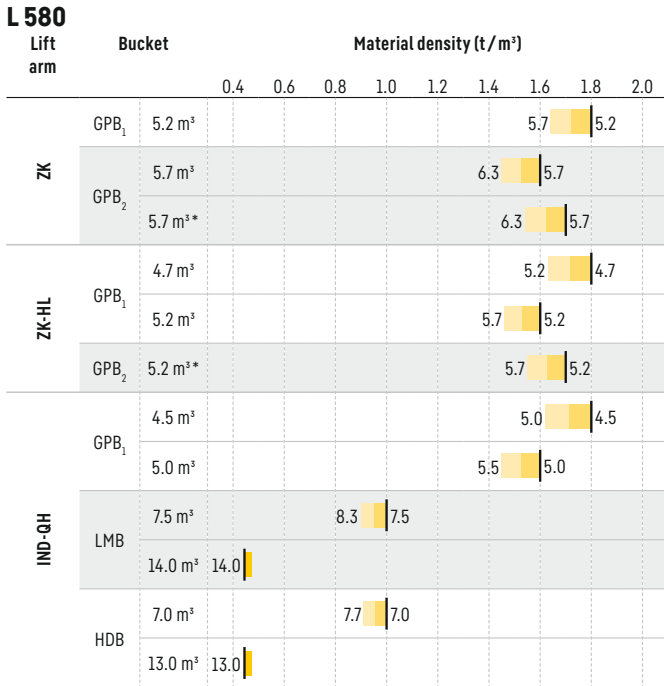
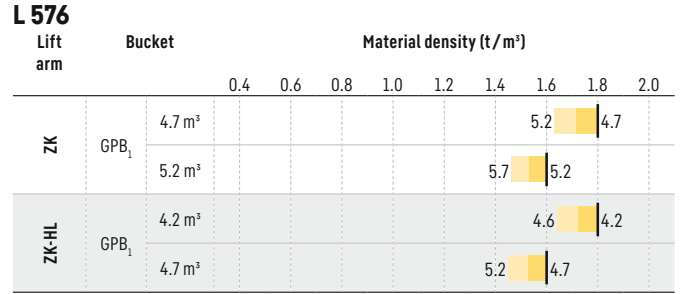
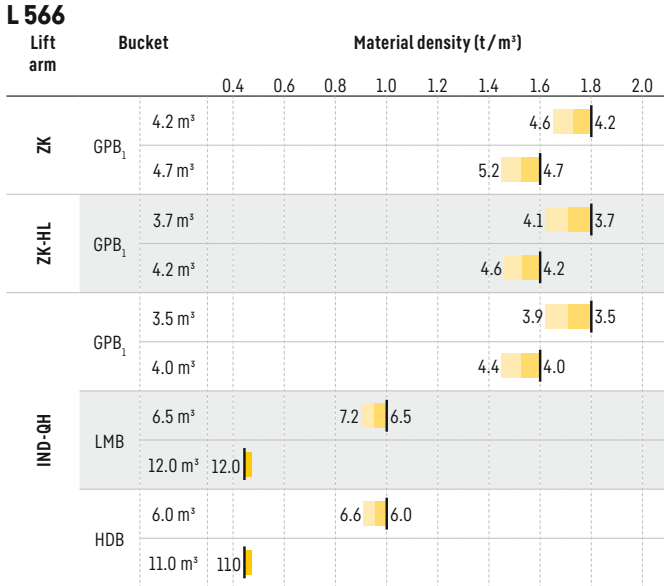

* Toothed buckets, hydraulic quick hitch and additional hydraulic circuits are not approved for rehandling application.

Bucket filling factor



110% 105% 100% 95%

Lift arm

ZK	Z-bar kinematics, standard lift arm length
ZK-HL	Z-bar kinematics, High Lift
IND-QH	Industrial lift arm with quick hitch, standard lift arm length

Bucket

GPB ₁	General purpose bucket (Excavation bucket)
GPB ₂	General purpose bucket (Rehandling bucket)
RB	Rock bucket
LMB	Light material bucket
HDB	High-dump bucket

For wheel loaders with large light material buckets and high-dump buckets or log grapples, we supply visual aids such as mirrors or cameras for front area monitoring that meet the requirements of the ISO 5006:2017 field of vision test.

Bulk material densities and bucket filling factors

		t/m ³	%			t/m ³	%			t/m ³	%
Gravel	moist	1.9	105	Earth	dry	1.3	115	Glass waste	broken	1.4	100
	dry	1.6	105		wet excavated	1.6	110		solid	1.0	100
	crushed stone	1.5	100		Topsoil	1.1	110		Compost	dry	0.8
Sand	dry	1.5	105	Basalt	1.95	100	wet	1.0	110		
	wet	1.9	110	Granite	1.8	95	Wood chips / Saw dust	0.5	110		
Gravel and Sand	dry	1.7	105	Sandstone	1.6	100	Paper	shredded / loose	0.6	110	
	wet	2.0	100	Slate	1.75	100	recovered paper / cardboard	1.0	110		
Sand / Clay		1.6	110	Bauxite	1.4	100	Coal	heavy material density	1.2	110	
Clay	natural	1.6	110	Limestone	1.6	100	light material density	0.9	110		
	dry	1.4	110	Gypsum	1.8	100	Waste	domestic waste	0.5	100	
Clay / Gravel	dry	1.4	110	Coke	0.5	110	bulky waste	1.0	100		
	wet	1.6	100	Slag	1.8	100					

Tipping load



What is tipping load?

Load at centre of gravity of working equipment, so that the wheel loader just begins to tip over the front axle. This is the most unfavourable static-load position for the wheel loader. Lifting arms horizontal, wheel loader fully articulated at centre pivot.

Pay load.

The pay load must not exceed 50% of the tipping load when articulated. This is equivalent to a static stability-margin factor of 2.0.

Bucket capacity.

The bucket volume is determined from the pay load.

$$\text{Pay load} = \frac{\text{Tipping load, articulated}}{2}$$

$$\text{Bucket capacity} = \frac{\text{Pay load (t)}}{\text{Specific bulk weight of material (t/m}^3\text{)}}$$

Tyres



Tyre types

	Size and tread code		Change of operating weight kg	Width over tyres mm	Change in vertical dimensions* mm	Use
L 566 XPower						
Bridgestone	26.5R25 VJT	L3	160	2,970	14	Bulk material (firm ground conditions)
Bridgestone	26.5R25 VSDT	L5	1,038	2,970	50	Stone, Mining spoil (firm ground conditions)
Bridgestone	26.5R25 VSDL	L5	1,290	2,970	57	Stone, Scrap, Recycling (firm ground conditions)
Bridgestone	26.5R25 VSMS	L5	1,599	2,960	70	Scrap, Recycling, Slag (firm ground conditions)
Bridgestone	26.5R25 VSNT	L4	576	2,960	47	Gravel, Industry, Wood (firm ground conditions)
Bridgestone	750/65R25 VTS	L3	197	3,070	- 39	Gravel, Industry, Wood (all ground conditions)
Continental	26.5R25 EM-Master	L3	100	2,980	41	Bulk material (firm ground conditions)
Continental	26.5R25 EM-Master	L4	528	2,930	48	Gravel, Industry, Wood (firm ground conditions)
Goodyear	26.5R25 TL-3A+	L3	348	2,980	30	Sand, Gravel, Earthworks, Clay (all ground conditions)
Goodyear	26.5R25 GP-4D	L4	436	2,980	26	Gravel, Industry, Wood (firm ground conditions)
Goodyear	26.5R25 RL-4K	L4	776	2,990	63	Gravel, Industry, Stone (firm ground conditions)
Goodyear	26.5R25 RL-5K	L5	1,244	2,990	63	Stone, Scrap, Recycling (firm ground conditions)
Goodyear	26.5R25 RL-5S	L5	1,712	2,990	63	Scrap, Recycling, Slag (firm ground conditions)
Goodyear	26.5R25 RT-5D	L5	1,008	2,990	63	Stone, Mining spoil (firm ground conditions)
Goodyear	750/65R25 TL-3A+	L3	152	3,100	- 26	Sand, Gravel, Industry, Wood (all ground conditions)
Michelin	26.5R25 XHA2	L3	0	2,960	0	Sand, Gravel (all ground conditions)
Michelin	26.5R25 X MINE PRO	L5	1,188	3,010	58	Stone, Scrap, Recycling (firm ground conditions)
Michelin	26.5R25 XLD D2A	L5	696	2,970	38	Stone, Mining spoil (firm ground conditions)
Michelin	26.5R25 XTXL	L4	488	2,970	23	Gravel, Industry, Wood (firm ground conditions)
Michelin	750/65R25 XLD 65	L3T	- 4	3,060	- 57	Gravel, Industry, Wood (all ground conditions)
L 576 XPower / L 580 XPower						
Bridgestone	26.5R25 VJT	L3	160	2,970	14	Bulk material (firm ground conditions)
Bridgestone	26.5R25 VSDT	L5	1,038	2,970	50	Stone, Mining spoil (firm ground conditions)
Bridgestone	26.5R25 VSDL	L5	1,290	2,970	57	Stone, Scrap, Recycling (firm ground conditions)
Bridgestone	26.5R25 VSMS	L5	1,599	2,960	70	Scrap, Recycling, Slag (firm ground conditions)
Bridgestone	26.5R25 VSNT	L4	576	2,960	47	Gravel, Industry, Wood (firm ground conditions)
Bridgestone	750/65R25 VTS	L3	178	3,070	- 39	Gravel, Industry, Wood (all ground conditions)
Continental	26.5R25 EM-Master	L3	100	2,980	41	Bulk material (firm ground conditions)
Continental	26.5R25 EM-Master	L4	528	2,980	48	Gravel, Industry, Wood (firm ground conditions)
Goodyear	26.5R25 TL-3A+	L3	348	2,980	30	Sand, Gravel, Earthworks, Clay (all ground conditions)
Goodyear	26.5R25 GP-4D	L4	436	2,980	26	Gravel, Industry, Wood (firm ground conditions)
Goodyear	26.5R25 RL-4K	L4	776	2,990	63	Gravel, Industry, Stone (firm ground conditions)
Goodyear	26.5R25 RL-5K	L5	1,244	2,990	63	Stone, Scrap, Recycling (firm ground conditions)
Goodyear	26.5R25 RL-5S	L5	1,712	2,990	63	Scrap, Recycling, Slag (firm ground conditions)
Goodyear	26.5R25 RT-5D	L5	1,008	2,990	63	Stone, Mining spoil (firm ground conditions)
Goodyear	750/65R25 TL-3A+	L3	132	3,100	- 26	Sand, Gravel, Industry, Wood (all ground conditions)
Michelin	26.5R25 XHA2	L3	0	2,960	0	Sand, Gravel (all ground conditions)
Michelin	26.5R25 X MINE PRO	L5	1,188	3,010	58	Stone, Scrap, Recycling (firm ground conditions)
Michelin	26.5R25 XLD D2A	L5	696	2,970	38	Stone, Mining spoil (firm ground conditions)
Michelin	26.5R25 XTXL	L4	488	2,970	23	Gravel, Industry, Wood (firm ground conditions)
Michelin	750/65R25 XLD 65	L3T	- 24	3,060	- 57	Gravel, Industry, Wood (all ground conditions)
L 586 XPower						
Bridgestone	29.5R25 VJT	L3	146	3,260	15	Bulk material (firm ground conditions)
Bridgestone	29.5R25 VSDT	L5	1,370	3,270	50	Stone, Mining spoil (firm ground conditions)
Bridgestone	29.5R25 VSDL	L5	1,730	3,270	60	Stone, Scrap, Recycling (firm ground conditions)
Bridgestone	29.5R25 VSNT	L4	712	3,270	50	Gravel, Industry, Wood (firm ground conditions)
Continental	29.5R25 EM-Master	L3	144	3,260	20	Bulk material (firm ground conditions)
Continental	29.5R25 EM-Master	L4	504	3,280	40	Gravel, Industry, Wood (firm ground conditions)
Goodyear	29.5R25 TL-3A+	L3	532	3,290	36	Sand, Gravel, Earthworks, Clay (all ground conditions)
Goodyear	29.5R25 GP-4D	L4	504	3,260	24	Gravel, Industry, Wood (firm ground conditions)
Goodyear	29.5R25 RL-4K	L4	1,124	3,270	44	Gravel, Industry, Stone (firm ground conditions)
Goodyear	29.5R25 RL-5K	L5	1,600	3,310	66	Stone, Scrap, Recycling (firm ground conditions)
Goodyear	29.5R25 RT-5D	L5	1,508	3,300	56	Stone, Mining spoil (firm ground conditions)
Goodyear	29.5R25 RL-5S	L5	2,100	3,270	66	Scrap, Recycling, Slag (firm ground conditions)
Michelin	29.5R25 XHA2	L3	0	3,250	0	Sand, Gravel (all ground conditions)
Michelin	29.5R25 XLD D2A	L5	936	3,260	26	Stone, Mining spoil (firm ground conditions)
Michelin	29.5R25 XTXL	L4	606	3,280	26	Gravel, Industry, Wood (firm ground conditions)
Michelin	29.5R25 X MINE PRO	L5	1,412	3,310	42	Stone, Scrap, Recycling (firm ground conditions)

* The stated values are theoretical and may deviate in practice.

Before operating the vehicle with tyre foam filling or tyre protection chains, please discuss this with the Liebherr-Werk Bischofshofen GmbH.

The Liebherr wheel loaders

Wheel loader



		L 504 Compact	L 506 Compact	L 507 Stereo	L 508 Compact	L 509 Stereo	L 514 Stereo
Tipping load	kg	3.000	3.500	3.750	3.900	4.430	5.750
Bucket capacity	m ³	0,7	0,8	0,9	1,0	1,2	1,5
Operating weight	kg	4.600	4.970	5.550	5.700	6.390	8.860
Engine output	kW / HP	34 / 46	47,5 / 64	50 / 68	47,5 / 64	54 / 73	76 / 103

Wheel loader



		L 518 Stereo	L 526	L 538	L 546	L 550 XPower
Tipping load	kg	6,550	8,730	9,650	11,010	12,500
Bucket capacity	m ³	1,7	2,2	2,6	3,0	3,4
Operating weight	kg	9,190	13,170	14,520	15,410	18,550
Engine output	kW / HP	76 / 103	116 / 158	129 / 175	138 / 188	163 / 222

Wheel loader



		L 556 XPower	L 566 XPower	L 576 XPower	L 580 XPower	L 586 XPower
Tipping load	kg	13,750	15,900	17,600	19,200	21,600
Bucket capacity	m ³	3,7	4,2	4,7	5,2	6,0
Operating weight	kg	19,600	23,900	25,700	27,650	32,600
Engine output	kW / HP	183 / 249	203 / 276	218 / 296	233 / 317	263 / 358

01.24

Environmental protection can help you earn money!



Always in fuel saving mode with the Liebherr fuel-saving calculator

100% power with up to 30 % less fuel consumption – the Liebherr fuel saving calculator shows how much fuel can be saved compared to similar machines. The online application is available free of charge and provides a quick and simple overview of fuel savings per year in euros. The calculation is based on average fuel consumption, operating hours per year and the current fuel price. The potential savings when operating a Liebherr wheel loader are impressive – see for yourself!

	Ø Litres / hour*
L 526: 2.1 m ³	5.92
L 538: 2.6 m ³	6.53
L 546: 2.8 m ³	7.51
L 550: 3.4 m ³	9.59
L 556: 3.7 m ³	10.63
L 566: 4.2 m ³	12.79
L 576: 4.7 m ³	13.69
L 580: 5.2 m ³	14.31
L 586: 6.0 m ³	17.56

* Wheel loader in operation with a customer-specific machine design.
Averages data from MyLiebherr Performance, calculated on 19/11/2024.



Experience just how much fuel you can save!
www.encyplus.liebherr.com

Equipment

 Basic wheel loader	L 550	L 556	L 566	L 576	L 580	L 586
Additional handrails left	●	●	●	●	●	●
Additional handrails right	+	+	+	+	+	+
Air pre-cleaner TOP AIR	+	+	+	+	+	+
Automatic central lubrication system	+	+	+	+	+	●
Automatic delayed engine stop	+	+	+	+	+	+
Auxiliary heater (Additional heating with engine preheating)	+	+	+	+	+	+
Battery main switch (lockable)	●	●	●	●	●	●
Chassis protection front	+	+	+	+	+	+
Chassis protection rear	+	+	+	+	+	+
Combined inching-braking system	●	●	●	●	●	●
Cooling water pre-heating 230 V	+	+	+	+	+	+
Crash protection, rear	+	+	+	+	+	+
DEF tank	●	●	●	●	●	●
Dust protection for alternator	+	+	+	+	+	+
Electronic tractive force regulation for difficult ground conditions	●	●	●	●	●	●
Fire extinguisher 6 kg	+	+	+	+	+	+
Fluff trap for radiator	+	+	+	+	+	+
Fuel pre-filter	●	●	●	●	●	●
Fuel pre-filter with pre-heating	+	+	+	+	+	+
Guard for headlights	+	+	+	+	+	+
Headlights halogen (double design on engine hood)	●	●	●	●	●	●
Headlights LED (double design on engine hood)	+	+	+	+	+	+
Large-mesh radiator	+	+	+	+	-	-
Liebherr biodegradable hydraulic oil	+	+	+	+	+	+
Liebherr SCR technology incl. diesel particle filter	●	●	●	●	●	●
Liebherr weighing system with "Truck Payload Assist" (cannot be certified as a regulated weights and measure device)	+	+	+	+	+	+
Lockable doors and engine hood	●	●	●	●	●	●
Multi-disc limited slip differentials in both axles	●	●	●	●	●	●
Parking brake	●	●	●	●	●	●
Pre-heat system for cold starting	●	●	●	●	●	●
Ramming guard with guard	+	+	+	+	+	-
Rear license panel light	+	+	+	+	+	+
Reversible fan drive	+	+	+	+	+	+
Ride control	●	●	●	●	●	●
Road travel counterweight	●	●	+	-	-	-
Speed limiter 20 km/h as a factory preset	+	+	+	+	+	+
Speed limiter V _{MAX} adjustable key on the control unit	●	●	●	●	●	●
Toolbox with toolkit	●	●	●	●	●	●
Towing hitch	●	●	●	●	●	●
Travel light (with additional headlights) on front section halogen	+	+	+	+	+	+
Travel light (with additional headlights) on front section LED	+	+	+	+	+	+
Tunnel package	+	+	+	+	-	-
Turbocharger insulation	+	+	+	+	+	+
Widening for mudguard	+	+	+	+	+	+

 Equipment	L 550	L 556	L 566	L 576	L 580	L 586
1st additional electro-hydraulic function for continuous sweeper and snow blower operation	+	+	+	+	+	+
1st electro-hydraulic, proportional additional function, adjustable delivery flow	+	+	+	+	+	+
2nd additional electro-hydraulic function for continuous sweeper and snow blower operation	+	+	+	+	+	-
2nd electro-hydraulic, proportional additional function, adjustable delivery flow	+	+	+	+	+	-
Adjustable tipping speed	●	●	●	●	●	●
Automatic bucket return programmable	●	●	●	●	●	●
Automatic lift arm position and lowering programmable	●	●	●	●	●	●
Bucket tilt assistant	+	+	+	+	+	+
Float position	●	●	●	●	●	●
Fork carrier and pallet forks	+	+	+	+	+	+
High Lift arms	+	+	+	+	+	+
High-dump bucket	+	+	+	+	+	+
Hydraulic quick hitch	+	+	+	+	+	+
Hydraulic quick hitch Solidlink	+	+	+	+	+	-
Industrial lift arm	+	+	+	-	+	-
Lift arm Z-bar kinematics	●	●	●	●	●	●
Light material bucket	+	+	+	+	+	+
Loading buckets incl. a range of cutting tools	+	+	+	+	+	+
Log grapple	+	+	+	-	+	-
Pipe break protection	+	+	+	+	+	+
Pressure relief for hydraulic additional function	+	+	+	+	+	+
Stroke limit damping	+	+	+	+	+	+
Tilt cylinder protection	+	+	+	+	+	+
Visualisation of the equipment position	●	●	●	●	●	●
Working hydraulics lockout	●	●	●	●	●	●

Equipment

 Operator's cab	L 550	L 556	L 566	L 576	L 580	L 586
3 way continuously adjustable steering column (height-adjustable, tilting, folding)	●	●	●	●	●	●
Access assistance to facilitate cleaning windscreen	●	●	●	●	●	●
Adapter plate for additional fastening on the multi-function rail	+	+	+	+	+	+
Adaptive working lighting	+	+	+	+	+	+
Air conditioning system	●	●	●	●	●	●
Amber beacon swiveling / fixed	+	+	+	+	+	+
Audible horn control integrated into Liebherr control lever	+	+	+	+	+	+
Automatic air conditioning system	+	+	+	+	+	+
Bucket return with button integrated into Liebherr control lever	+	+	+	+	+	+
Cigarette lighter	●	●	●	●	●	●
Clothes hooks (2 pieces)	●	●	●	●	●	●
Cool box	+	+	+	+	+	+
Electronical theft protection with code	+	+	+	+	+	+
Electronical theft protection with key with/without driver identification	+	+	+	+	+	+
Exterior mirror, electrical adjustable, with heating	+	+	+	+	+	+
Exterior mirror, tiltable and adjustable	●	●	●	●	●	●
Fire extinguisher in cab 2 kg	+	+	+	+	+	+
First aid kit	+	+	+	+	+	+
Floor mat	●	●	●	●	●	●
Headlights front, double design, halogen	●	●	●	●	●	●
Headlights front, double design, LED	+	+	+	+	+	+
Headlights rear, double design, LED	+	+	+	+	+	+
Headlights rear, single design, halogen / LED	+	+	+	+	+	+
Headlights rear, triple design, LED	+	+	+	+	+	+
Integrated tyre pressure monitoring system	+	+	+	+	+	+
Interior mirror left and right	+	+	+	+	+	+
Interior mirror right	●	●	●	●	●	●
Joystick steering	+	+	+	+	+	+
Liebherr Connect						
MyLiebherr Maintenance	+	+	+	+	+	+
MyLiebherr Performance	+	+	+	+	+	+
MyLiebherr Portal*	●	●	●	●	●	●
Liebherr control lever moving with operator's seat (incl. kick down, travel direction)	●	●	●	●	●	●
Liebherr control lever with mini-joystick for 1st and 2nd electro-hydraulic, proportional additional function moving with operator's seat	+	+	+	+	+	+
Liebherr key with remote control incl. Coming Home / Leaving Home function	+	+	+	+	+	+
Liebherr multi-lever control system moving with operator's seat (incl. kick down, travel direction)	+	+	+	+	+	+
Operating hour meter (integrated in display unit)	●	●	●	●	●	●
Operating hour meter (mechanic)	+	+	+	+	+	+
Operator seat "Comfort" - with longitudinal absorption and seat heating	●	●	●	●	●	●
Operator seat "Premium" - with longitudinal and transverse absorption, seat climate control	+	+	+	+	+	+

 Operator's cab	L 550	L 556	L 566	L 576	L 580	L 586
Operator's cab without steering wheel / steering column (not available as street legal) - joystick steering only	+	+	+	+	+	+
Particle filter F7	●	●	●	●	●	●
Power socket 12 V	●	●	●	●	●	●
Power socket USB	●	●	●	●	●	●
Premiumdisplay (Touchscreen), with height adjustment and tilting function	●	●	●	●	●	●
Preparation for protective ventilation and dust filtrating device	+	+	+	+	+	+
Preparation for radio installation	+	+	+	+	+	+
Radio Liebherr "Comfort" (DAB+ / USB / AUX / BLUETOOTH / handsfree set)	+	+	+	+	+	+
Radio Liebherr "Standard" (USB / AUX)	+	+	+	+	+	+
Rear window heated electrically	●	●	●	●	●	●
Sliding window left/right	●	●	●	●	●	●
Slipcover for operator seat	+	+	+	+	+	+
Soundproof ROPS / FOPS cab	●	●	●	●	●	●
Steering stabilisation	●	●	●	●	●	●
Storage box left	●	●	●	●	●	●
Sunblind front	●	●	●	●	●	●
Sunblind rear	+	+	+	+	+	+
Wide angle mirror	+	+	+	+	+	+
Windscreen guard	+	+	+	+	+	+
Windscreen wiper single-sweep function with button	+	+	+	+	+	+
Wipe and wash system	●	●	●	●	●	●

 Safety	L 550	L 556	L 566	L 576	L 580	L 586
Active personnel detection at the rear	+	+	+	+	+	+
Back-up alarm acoustic / visual	+	+	+	+	+	+
Country-specific versions	+	+	+	+	+	+
Emergency steering system	●	●	●	●	●	●
Rear space monitoring with camera (with Liebherr camera via Liebherr display)	●	●	●	●	●	●
Reversing obstruction detector	+	+	+	+	+	+
Roof camera for front area monitoring (with Liebherr camera via Liebherr display)	+	+	+	+	+	+
Skyview 360°	+	+	+	+	+	+

- = Standard
- + = Option
- = not available
- * = activation required free of charge

Further information can be found in the brochure "Assistance systems for wheel loaders" or you can find here:



Here you can download our wheel loader brochures:



The Liebherr Group

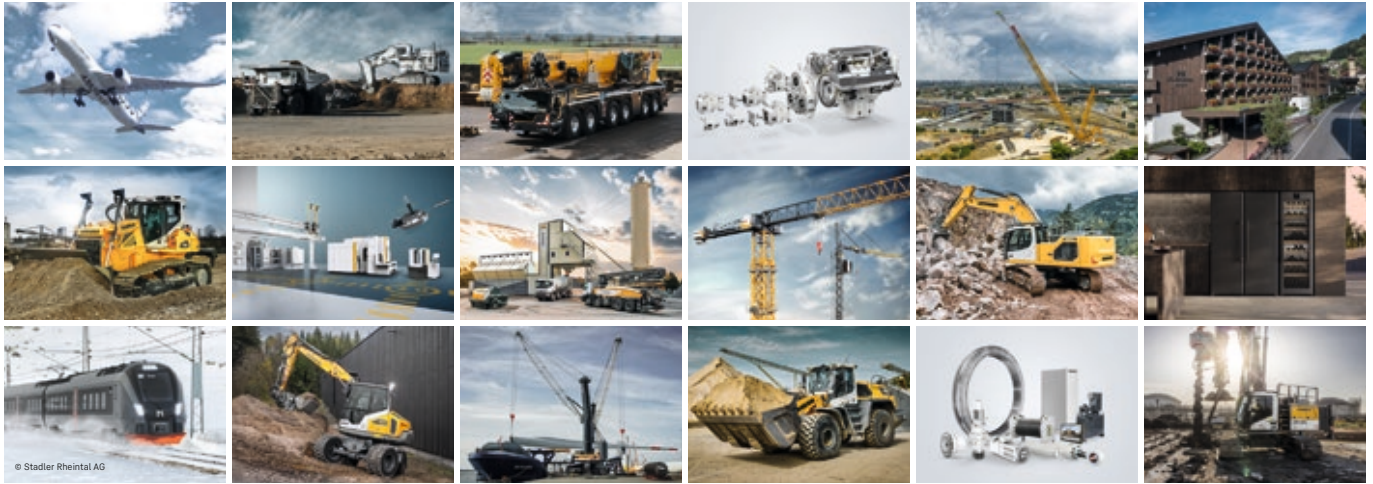

Global and independent: more than 75 years of success

Liebherr was founded in 1949 when, with the development of the world's first mobile tower crane, Hans Liebherr laid the foundations for a family-run company which now has more than 55,000 employees and comprises over 150 companies across every continent. The holding company of the Group is Liebherr-International AG in Bulle, Switzerland, whose shareholders are exclusively members of the Liebherr family.

Technology leadership and pioneering spirit

Liebherr is a pioneer and its forward-looking approach has seen it make important contributions to technology history over a wide variety of industries. Employees throughout the world continue to share the courage of the company founder, sharing a passion to produce innovative products and a determination to provide world-leading equipment and machinery.

Diversified product programme

Liebherr is one of the world's biggest construction machine manufacturers and provides high-quality, user-oriented products and services. Its product range includes the product segments earthmoving, material handling, deep foundation, mining, mobile and crawler cranes, tower cranes, concrete technology, maritime cranes, aerospace and transportation systems, gear technology and automation systems, refrigerators and freezers, components and hotels.

Customised solutions and maximum customer value

Liebherr solutions are characterised by precision, implementation and longevity. The company is committed to technological excellence and to providing customers with solutions that match their needs exactly. For Liebherr, customer focus does not end with delivery of a product but continues through a comprehensive range of back-up and support services.

www.liebherr.com

Liebherr-Werk Bischofshofen GmbH

Postfach 49 · 5500 Bischofshofen, Austria · Phone +43 50809-10
info.lbh@liebherr.com · www.liebherr.com · www.facebook.com/LiebherrConstruction