

# Fully integrated Refrigerator



 German  
Engineering

**LIEBHERR**



## Optimal freshness

---

When it comes to groceries, you care about top quality and an authentic culinary experience. You find joy in taking small detours to explore local stalls brimming with fresh, regional fruits and vegetables, or perhaps indulging in your favourite imported delicacies like exotic fruits, artisanal cheeses, or olives. Wouldn't it be great if you could still taste this quality, even after several days in the fridge? Almost as if time were standing still? We think it would.

That is what motivates us to constantly develop new and even better solutions that guarantee perfect storage conditions for all kinds of groceries. For long-lasting freshness, to protect valuable vitamins, and for food that tastes as if it had just been bought or harvested.



Images for representation purpose only, may vary from actuals.



Hotels



Aerospace and transportation systems



Gear technology and automation systems



Components



Mobile and crawler cranes



Material handling



Concrete technology



Specialist civil engineering



Tower Cranes



Mining



Earth moving



Maritime cranes



Refrigerators and freezers



## A tradition of reliability admired the world over.

For 75 years, Liebherr has offered high-quality products for pioneering industries. With our customers and partners all over the world, we constantly reach new heights.

### One big family

The Liebherr Group was established in 1949 by Hans Liebherr. With a history spanning 75 years, the family-run company is characterised by stability and reliability. Liebherr is one of the biggest manufacturers of construction equipment and is also successful in many other industries. The Group has a decentralised organisation with more than 50,000 employees worldwide and is divided into independently operating business units.

The Group now encompasses 13 product segments – earthmoving machinery, material handling technology, deep foundation machines, mining, mobile and crawler cranes, tower cranes, concrete technology, maritime cranes, aerospace and transportation systems, gear

technology and automation systems, refrigerators and freezers, components and hotels – and comprises more than 140 companies across all continents. The holding company of the Group is Liebherr-International AG in Bulle (Switzerland), all of whose shareholders are members of the Liebherr family.

### Cutting-edge combined with experience: Appliances

The Appliances division was established at the Ochsenhausen site in 1954, and for many years it has played an important part in the development of the Group.

For 70 years, Liebherr has been a premium manufacturer of innovative refrigerators and freezers for domestic and commercial use. With an annual production of more than 2.2 million appliances, Liebherr is one of Europe's leading suppliers of cooling and freezing appliances. The five production sites in Ochsenhausen (Germany), Lienz (Austria), Radinovo (Bulgaria), Kluang (Malaysia) and Aurangabad (India) form a manufacturing network for refrigerators and freezers that meet all the most up-to-date standards.

Liebherr is active all over the world. With a dense network of sales subsidiaries and offices in Bulgaria, Germany, the UK, Austria, Canada, Malaysia, Russia, Switzerland, Singapore, South Africa, the USA, and India. The refrigeration and freezing specialists ensure that customers receive expert advice and service and maintenance work is provided professionally on-site.

## Quality

# Even the smallest detail deserves the utmost attention.

We prioritise uncompromising quality – down to the tiniest screw. And we have done so from the very start. We have been manufacturing high-quality refrigerators and freezers and selling them worldwide since 1954. However, at heart, we are still a family business with deep roots in Germany. It is here that we continue to develop all our products just as before. German engineering – out of loyalty to our founder and with the knowledge built up by generations of engineers.

### Convenience for everybody.

Our new fully integrated appliances are available in different series: Pure, Plus, Prime and Peak. But whatever series you opt for, every single Liebherr comes with uncompromising Liebherr quality. This is because even in the Pure series, every appliance comes with a wide range of features. One example is NoFrost – the automatic defrosting function. Another is our EasyFresh technology for storing fruit and vegetables. Then there is our DuoCooling feature. With two separate refrigerant circuits, it ensures that no air is exchanged between the fridge and freezer compartments. The stored groceries do not dry out, and no odours are transferred.



### Built to last.

You can experience our quality standards in the smallest of details. For example, before a door hinge is approved by us, it must pass through at least 100,000 opening cycles. This corresponds to a usage period of more than 15 years. We also test all other functional parts to ensure they can last just as long.

And if, contrary to expectations, a small detail no longer meets your requirements, you or our premium service partners can usually correct it quickly. Because all our appliances are extremely repair-friendly. We keep all essential spare parts in stock. This practice is not just sustainable; it also saves you money on minor repairs or purchasing a new appliance.



### Power Cooling

Do you want to be sure that the cold is distributed as evenly as possible in your refrigerator? If so, the PowerCooling system is what you need. The fan – as powerful as it is quiet – distributes the cold air efficiently throughout the entire refrigeration compartment.

Freshness and convenience

## Tasty for longer

You don't compromise when you're shopping. You look for natural ingredients, the best quality, and maximum freshness. Of course, anyone who values good food wants to keep it fresh for as long as possible. That is precisely why we have developed innovative freshness technologies and improved them year after year, so your food still tastes fresh after some time in the refrigerator.



### Bio Fresh

The reliable BioFresh technology keeps food at a temperature just above 0°C, much cooler than in the rest of the appliances. With the perfect humidity in the Fruits and Vegetable Safe, they stay fresh even longer in the airtight compartment. Meat, fish and dairy products enjoy ideal conditions in the Meat & Dairy Safe.



### Duo Cooling

Our basic technology is in all fridge-freezers. Two completely separate cooling circuits ensure that there is no air exchange between the fridge and freezer compartments. The food neither dries out nor spreads odour.



### Door-on-door

This technology allows custom panels to be affixed directly onto the appliance door so that the hinges are concealed, plus the cabinet and the fridge open as one, ensuring a wide range of design options and easy installation.



### Ice Maker

Liebherr's automatic IceMaker produces flawless crescent ice and keeps a constant supply on hand for every occasion.



### Flex System

Small and delicate fruit in the refrigerator can easily roll out of sight or become crushed. That's why your Liebherr comes with the FlexSystem. Two flexibly positionable boxes in the BioFresh safe ensure everything is arranged and organised. And they also safely protect even the smallest raspberry from bruising or from being mixed up with other foods.



### Vario Space

Want to store a multi-layer ice cream cake safely until the summer party? No problem with your Liebherr freezer: Sometimes you just need more space, and it's prepared for just that. With VarioSpace, you can remove individual freezer drawers and the horizontal glass dividers below them, and hey presto, you have an extra-large storage space.

## Design

# Timeless and elegant. Design for every kitchen.

Hidden behind the panels of your integrated kitchen, your Liebherr is inconspicuous and lets the design of the kitchen take the spotlight. But once you open it, it's immediately apparent that behind the door lies something very special.

### Design meets functionality.

Purist and timeless, on one hand. Elegant and exclusive on the other. The new design language blends seamlessly into any interior: The precise craftsmanship, an eye for detail and the harmonious combination of materials, shapes and colours create an aesthetically pleasing whole. This is subtly highlighted by the new lighting concept, LightTower.



#### Tower LED

The Tower LED lighting concept evenly illuminates the interior while supporting the glass shelves. Flexible, space-saving, unique.



## Fully integrated key features

# Integrated key features



#### Divisible glass shelf

One half of the split glass shelf can slide underneath the other to provide even greater flexibility for food storage and the accommodation of the taller containers. All glass shelves are made from safety glass and can be positioned at different height levels.



#### Side panel heating

Side-by-Side appliances come with an embedded side panel heating system, which utilises the refrigerant's heat and prevents moisture from condensing between the appliances. The process is energy efficient because no additional energy needs to be consumed.



#### Reversible door hinges

It gives flexibility to open the door from either the left or the right side, depending on the user's preference or space constraints. This feature enhances convenience and adaptability, making it suitable for different kitchen layouts.



#### Magic Eye

Our control panel ensures all functions are easy and convenient to use as well as guarantees that the settings selected remain accurate and constant.



#### Soft System

The SoftSystem closing damper is comfortable and highly practical in everyday use. When the door is closed, the SoftSystem integrated with the door dampens the movement and ensures particularly soft closing even when the door interior is fully loaded.



#### Soft Telescopic Rails

Drawers with the SoftTelescopic feature are fully extendable. They are designed with a convenient self-retracting and soft-closing mechanism. The drawers can be removed with the door open at an angle of only 90°.

Bio  
Fresh

# BioFresh: enjoy lasting freshness

With BioFresh technology, food keeps fresh for much longer. When stored at a temperature close to 0°C and at the correct humidity level, many foods retain their nutrients, such as vitamins and minerals, for far longer than in a conventional fridge compartment.

## Considerably longer shelf life

Newly purchased and freshly harvested foods are to be stored properly so that their nutrients are preserved for longer. The dry conditions in the DrySafe is ideal for storing meat, fish and dairy products. The shelf life and freshness of most fruits and vegetables can be significantly extended by storing them in a fridge, particularly in the Fruit & Vegetable safe. The high humidity in this storage environment means less moisture is lost from food, keeping fruit and vegetables fresh and crisp. By adjusting to low humidity, the Fruit & Vegetable Safe can also be used as an additional DrySafe.

## Less packaging is better for the environment

More and more packaging waste is being produced, which is harmful to our environment. This is one of the reasons why the Fruit & Vegetable Safe was developed. Here, fruits and vegetables are best stored unpackaged, and they also maintain their freshness for longer. This means there is nothing to stop you from shopping at the farmer's market or in the packaging-free supermarket. The practical FlexSystem (depending on the model) helps to separate and sort products neatly and cleanly.

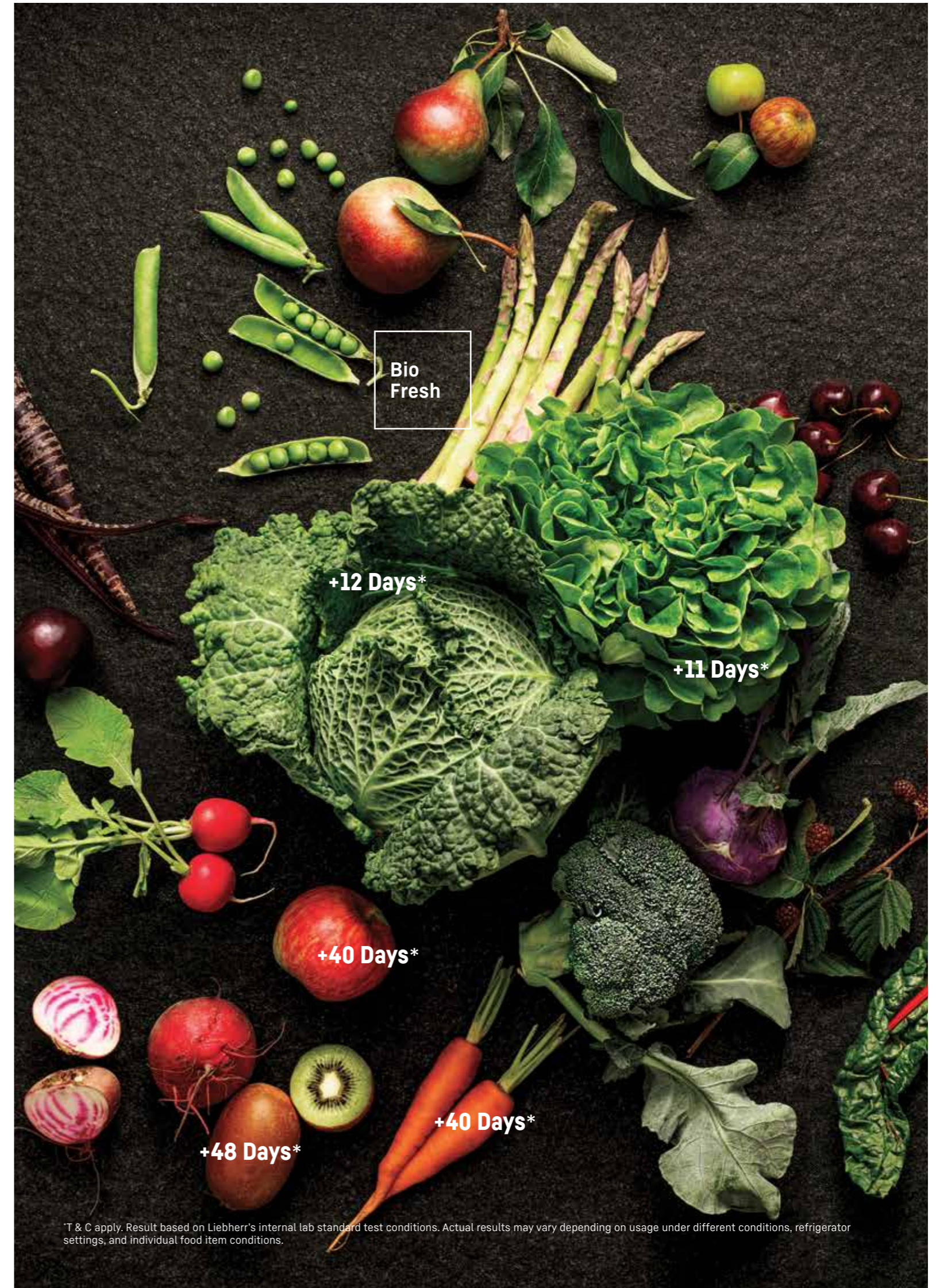

\*T & C apply. Result based on Liebherr's internal lab standard test conditions. Actual results may vary depending on usage under different conditions, refrigerator settings, and individual food item conditions.

# Fridge-Freezer



Images for representation purpose only, may vary from actuals.

**Fridge & Freezer Combination with no frost**

**FiBBmA 2566**

Prime

Type	Fixed door / Built-in appliance for integrated use
Total volume	249
Aperture dimensions in cm (h / w / d)	177 / 55.9 / 54.4

Bio Fresh	Duo Cooling	No Frost	Super Frost	Soft System	Soft Telescopic Rails	Ice Maker	Vario Space	Super Cool
Power Cooling	Frost Safe							

**Controls**

- Type of control: MagicEye, touch electronic Digital temperature LCD display for fridge and freezer compartments
- Door alarm: acoustic
- Alarm in case of malfunction: visual and acoustic

**Fridge compartment**

- PowerCooling: Forced air system
- Door interior: Premium GlassLine storage shelves with bottle holder, removable VarioBoxes, adjustable egg tray, butter dish
- Bottle shelf: Variable bottle shelf
- Interior light : Tower LED at both sides
- LED BioFresh lighting
- BioFresh-Safes: 2 BioFresh safes with SoftTelescopic rails, of which 1 can be set variably to HydroSafe or DrySafe, 1 FlexSystem

**Freezer compartment**

- Interior light: LED lighting
- Number of drawers: 4 drawers, VarioSpace
- IceMaker with fixed 3/4" water connection
- Ice cube capacity in 24 hours: 0.8 kg
- Ice cube stock: 1 kg
- Cold storage accumulators: 2

**Features**

- Side-by-Side concept: Side-panel heating on both sides, suitable for combination with other fridges, freezers and/or wine appliances
- Door hinges: Reversible Door Hinge
- Divisible glass shelf
- EAN No. 4059303003498



MRP\*  
**₹ 399,990**

\*Price is subject to change without notice. Please get in touch with our sales representative/channel partner for the latest price update.

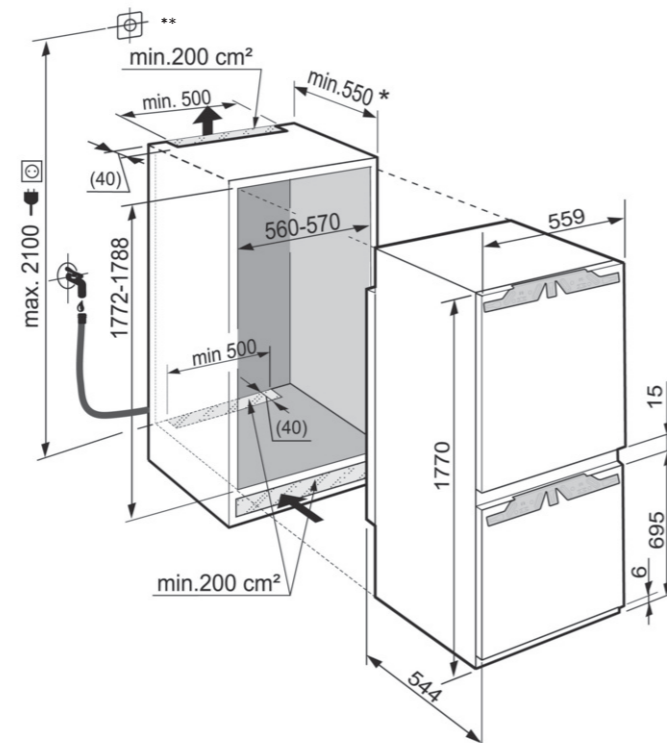

Generic product page: product images & features are for illustration purposes only. Model availability and specifications are subject to change without prior notice.

\*\*Recommended 560mm

**FiNBmA 2766**

Prime

Type	Fixed door / Built-in appliance for integrated use
Total volume	263
Aperture dimensions in cm (h / w / d)	177 / 55.9 / 54.4

Bio Cool	Duo Cooling	No Frost	Soft System	Ice Maker water tank	Frost Safe	Power Cooling	Super Cool	Super Frost
Vario Safe	Vario Space							

**Controls**

- Type of Control: MagicEye, key electronic Digital temperature display for fridge and freezer compartment
- Door alarm: acoustic
- Alarm in case of malfunction: visual and acoustic

**Fridge compartment**

- PowerCooling: Forced air system
- Door interior: Premium GlassLine storage shelves with bottle holder, removable VarioBoxes, adjustable egg tray, butter dish
- Interior light: Tower LED at left
- Fruit and vegetable bins: 1 BioCool-Box on telescopic rails with LED lighting

**Freezer compartment**

- Interior light: LED light
- Number of drawers: 4 drawers, VarioSpace
- Cold storage accumulators: 2
- IceMaker with water tank
- Ice cube capacity in 24 hours: 0.8 kg
- Ice cube stock: 1 kg

**Features**

- Side-by-Side concept: Side-panel heating on both sides, suitable for combination with other fridges, freezers and/or wine appliances
- Door hinges: Reversible door hinge
- Divisible glass shelf
- EAN-No. 4059303003542



MRP\*  
**₹ 314,990**

\*Price is subject to change without notice. Please get in touch with our sales representative/channel partner for the latest price update.

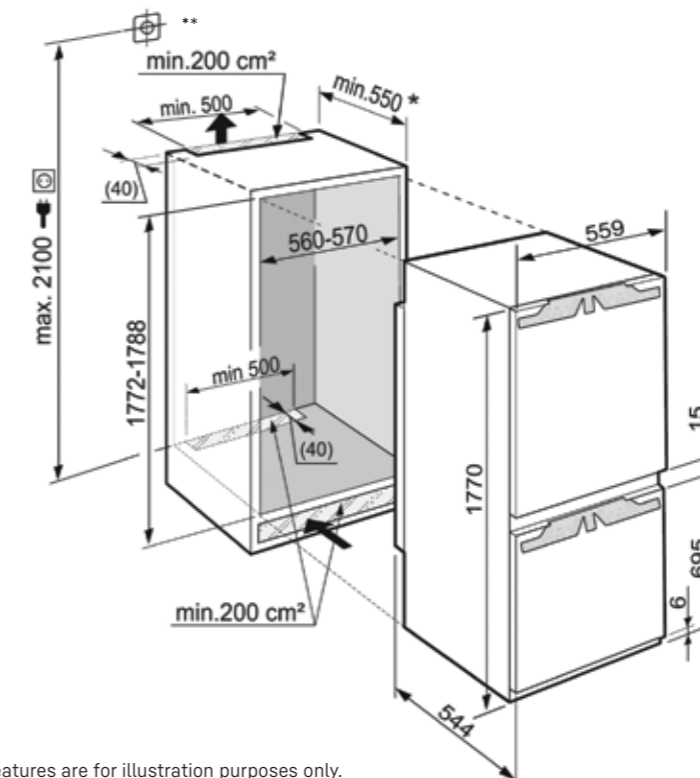

Generic product page: product images & features are for illustration purposes only. Model availability and specifications are subject to change without prior notice.

\*\*Recommended 560mm

**Fridge & Freezer Combination with no frost**

**FiBBmA 2556**  
Prime

Type	Fixed door / Built-in appliance for integrated use
Total volume	249
Aperture dimensions in cm (h / w / d)	177 / 55.9 / 54.4

Bio Fresh	Duo Cooling	No Frost	Super Frost	Soft System	Soft Telescopic Rails	Vario Space	Super Cool
Power Cooling	Frost Safe						

- Controls**
- Type of Control: MagicEye, touch electronic Digital temperature display for fridge and freezer compartments
  - Door alarm: acoustic
  - Alarm in case of malfunction: visual and acoustic
- Fridge compartment**
- PowerCooling: Forced air system
  - Door interior: Premium GlassLine storage shelves with bottle holder, removable VarioBoxes, adjustable egg tray, butter dish
  - Interior light: Tower LED at both sides
  - LED in BioFresh compartment
  - BioFresh safe: 2 BioFresh safe with SoftTelescopic rails, of which 1 can be set variably to Hydrosafe or Drysafe, 1 Flex System

- Freezer compartment**
- Interior light: LED lighting
  - Number of drawers: 3 drawers, VarioSpace
  - Ice cube tray: yes
  - Cold storage accumulators: 2
- Features**
- Side-by-Side concept: Side-panel heating on both sides, suitable for combination with other fridges, freezers and/or wine appliances
  - Door hinges: Reversible door hinge
  - Divisible glass shelf
  - EAN No. 4059303003481



MRP\*  
**₹ 324,990**

\*Price is subject to change without notice. Please get in touch with our sales representative/channel partner for the latest price update.

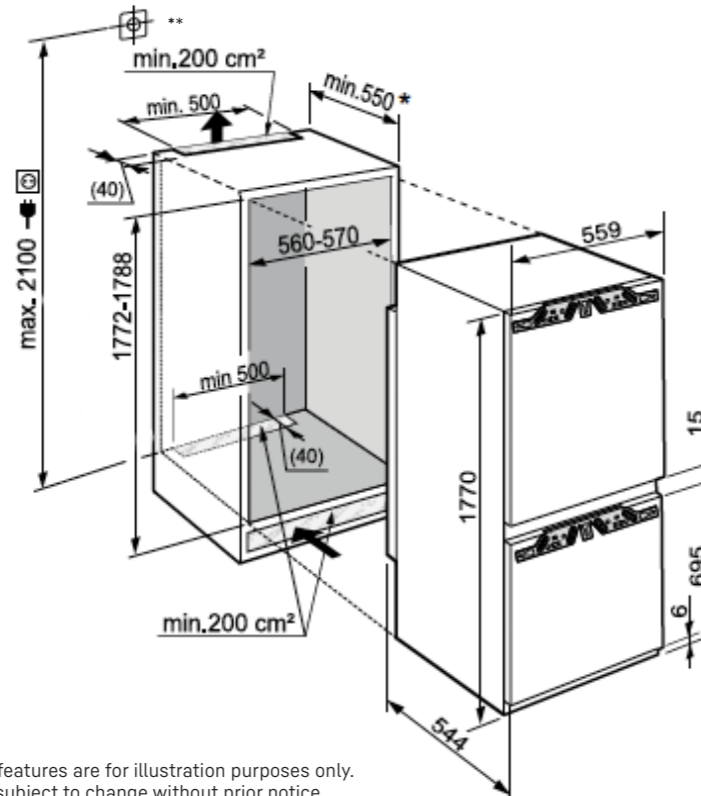

Generic product page: product images & features are for illustration purposes only. Model availability and specifications are subject to change without prior notice.

\*\*Recommended 560mm

**FiNBmA 2756**  
Prime

Type	Fixed door / Built-in appliance for integrated use
Total volume	263
Aperture dimensions in cm (h / w / d)	177 / 55.9 / 54.4

Bio Cool	Duo Cooling	No Frost	Frost Safe	Power Cooling	Super Cool	Super Frost	Vario Space	Soft System
----------	-------------	----------	------------	---------------	------------	-------------	-------------	-------------

- Controls**
- Type of Control: MagicEye, key electronic Digital temperature display for fridge and freezer compartment
  - Door alarm: acoustic
  - Alarm in case of malfunction: visual and acoustic
  - Digital temperature display for fridge and freezer compartments
- Fridge compartment**
- PowerCooling: Forced air system
  - Door interior: Premium GlassLine storage shelves with bottle holder, removable VarioBoxes, adjustable egg tray, butter dish
  - Interior light: Tower LED at left
  - Fruit and vegetable bins: 1 BioCool-Box on telescopic rails with LED lighting

- Freezer compartment**
- Interior light: LED light
  - Number of drawers: 3 drawers, of which 2 set on roller tracks, VarioSpace
  - Cold storage accumulators: 2
  - Ice cube tray: yes
- Features**
- Side-by-Side concept: Side-panel heating on both sides, suitable for combination with other fridges, freezers and/or wine appliances
  - Door hinges: Reversible door hinge
  - Divisible glass shelf
  - EAN No. 4059303003504



MRP\*  
**₹ 284,990**

\*Price is subject to change without notice. Please get in touch with our sales representative/channel partner for the latest price update.

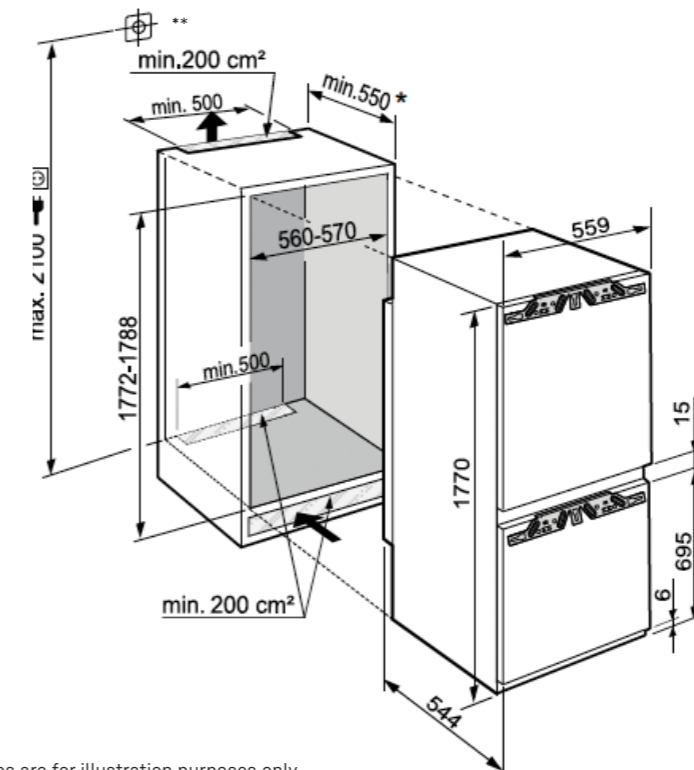

Generic product page: product images & features are for illustration purposes only. Model availability and specifications are subject to change without prior notice.

\*\*Recommended 560mm

**Fridge & Freezer Combination with no frost**

**FiNBmA 2714**

Pure

Type **Fixed door / Built-in appliance for integrated use**

Total volume **263**

Aperture dimensions in cm (h / w / d) **177 / 55.9 / 54.4**



**Controls**

- Type of Control: MagicEye, key electronic Digital temperature display for fridge and freezer compartment
- Door alarm: acoustic
- Alarm in case of malfunction: visual and acoustic

**Fridge compartment**

- PowerCooling: Forced air system
- Door interior: Comfort GlassLine storage shelves with bottle holder
- Adjustable egg tray
- Interior light: LED light
- Fruit and vegetable bins: 1 BioCool-Box on roller tracks

**Freezer compartment**

- Number of drawers: 3 drawers, VarioSpace
- Ice cube tray: yes

**Features**

- Side-by-Side concept: Side-panel heating on both sides, suitable for combination with other fridges, freezers and/or wine appliances
- Divisible glass shelf
- Door hinges: Reversible door hinge
- EAN No. 4059303003511



MRP\*

**₹ 254,990**

\*Price is subject to change without notice. Please get in touch with our sales representative/channel partner for latest price update.

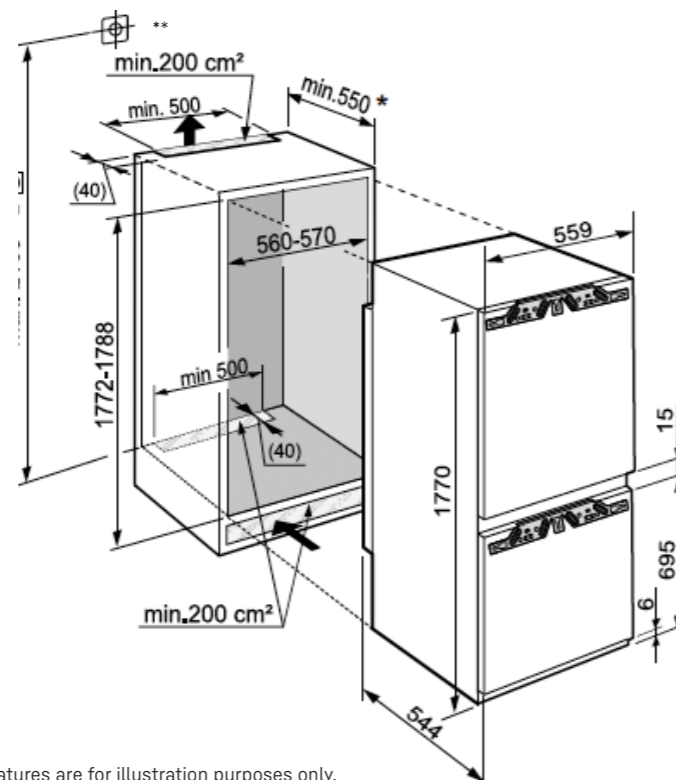

Generic product page: product images & features are for illustration purposes only. Model availability and specifications are subject to change without prior notice.

\*\*Recommended 560mm



# Fridge



Images for representation purpose only, may vary from actuals.

Refrigerator with BioFresh

**FiBFrC 3150**

Prime

Type	Fixed door / Built-in appliance for integrated use
Total volume	309
Aperture dimensions in cm (h / w / d)	177/55.9/54.4



**Controls**

- Type of Control: MagicEye, key electronic Digital temperature display
- Door alarm: acoustic
- Alarm in case of malfunction: visual and acoustic

**Fridge compartment**

- PowerCooling: Forced air system
- Door interior: Premium GlassLine storage shelves with bottle holder, removable VarioBoxes, adjustable egg tray, butter dish
- VarioSafe: Yes
- Bottle shelf: Variable bottle shelf
- Interior light: Tower LED on both sides
- LED in BioFresh compartment
- BioFresh-Safes: 3 BioFresh safes with SoftTelescopic rails, of which 2 can be set variably to HydroSafe or DrySafe, 1 FlexSystem

**Features**

- Side-by-Side concept: Side-panel heating on both sides, suitable for combination with other fridges, freezers and/or wine appliances
- Door hinges: Reversible door hinge
- Divisible glass shelf
- EAN No. 4059303003474



MRP\*

**₹ 254,990**

\*Price is subject to change without notice. Please get in touch with our sales representative/channel partner for the latest price update.

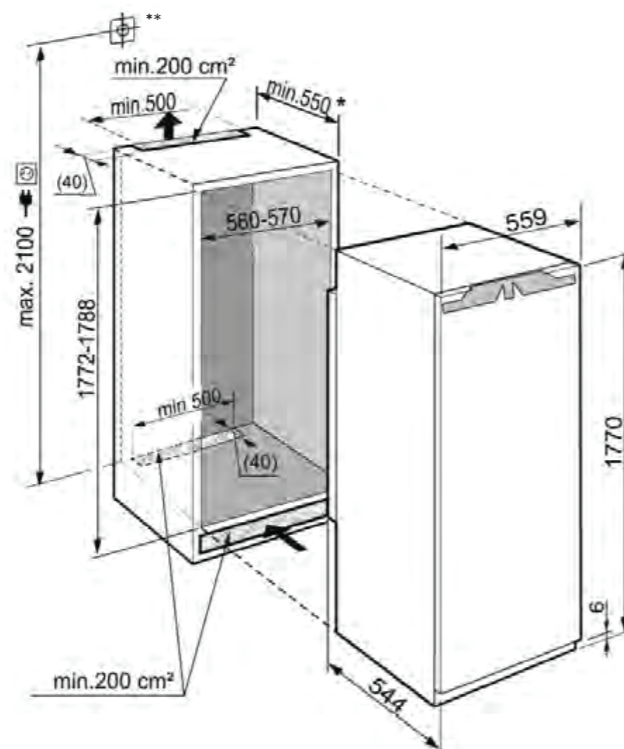

Generic product page: product images & features are for illustration purposes only. Model availability and specifications are subject to change without prior notice.

\*\*Recommended 560mm

**FiBFrC 3120**

Plus

Type	Fixed door / Built-in appliance for integrated use
Total volume	309
Aperture dimensions in cm (h / w / d)	177/55.9/54.4



**Controls**

- Type of Control: MagicEye, key electronic Digital temperature display
- Door alarm: acoustic
- Alarm in case of malfunction: visual and acoustic

**Fridge compartment**

- PowerCooling: Forced air system
- Door interior: Comfort GlassLine storage shelves with bottle holder, adjustable egg tray
- Interior light: LED light
- BioFresh-Safes: 3 BioFresh safes on telescopic rails, of which 1 can be set variably to HydroSafe or DrySafe VarioSafe
- Bottle shelf: Variable bottle shelf

**Features**

- Side-by-Side concept: Side-panel heating on both sides, suitable for combination with other fridges, freezers and/or wine appliances
- Door hinges: Reversible door hinge
- Divisible glass shelf
- EAN NO. 4059303003535



MRP\*

**₹ 204,990**

\*Price is subject to change without notice. Please get in touch with our sales representative/channel partner for the latest price update.

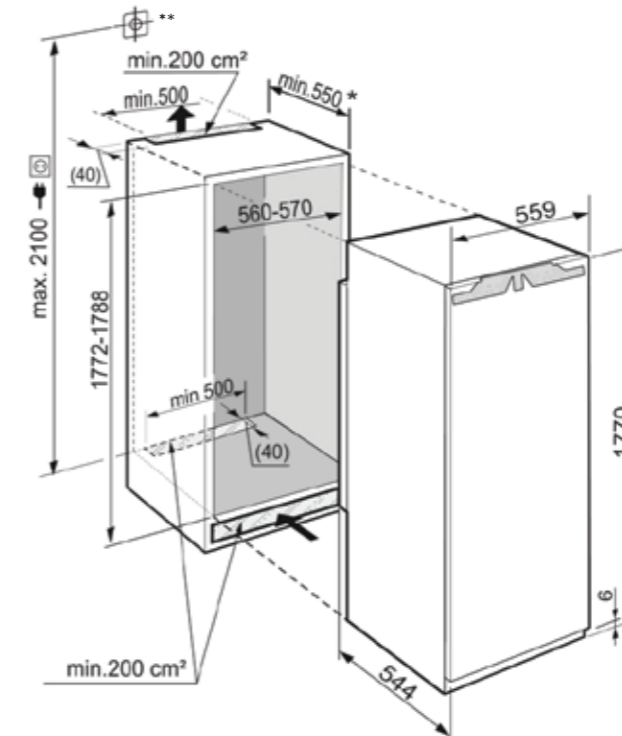

Generic product page: product images & features are for illustration purposes only. Model availability and specifications are subject to change without prior notice.

\*\*Recommended 560mm

# Freezer



Images for representation purpose only, may vary from actuals.

Freezer with NoFrost

**FiNFza 2276**  
Prime

Type	Fixed door / Built-in appliance for integrated use
Total volume	217
Aperture dimensions in cm (h / w / d)	177/55.9/54.4



**Controls**

- Type of Control: MagicEye, touch electronic Digital temperature display
- Door alarm: acoustic
- Alarm in case of malfunction: visual and acoustic

**Freezer compartment**

- Interior light: LED
- Number of drawers: 9 drawers, of which 5 set on telescopic rails
- IceMaker: with fixed 3/4" water connection
- Ice cube capacity in 24 hours: 0.8 kg
- Ice cube stock: 1.5kg
- VarioSpace: yes
- Cold storage accumulators: 2

**Features**

- Side-by-Side concept: Side-panel heating on both sides, suitable for combination with other fridges, freezers and/or wine appliances
- Door hinges: Reversible door hinge
- EAN No. 4059303003528



MRP#  
**₹ 299,990**

#Price is subject to change without notice. Please get in touch with our sales representative/channel partner for the latest price update.

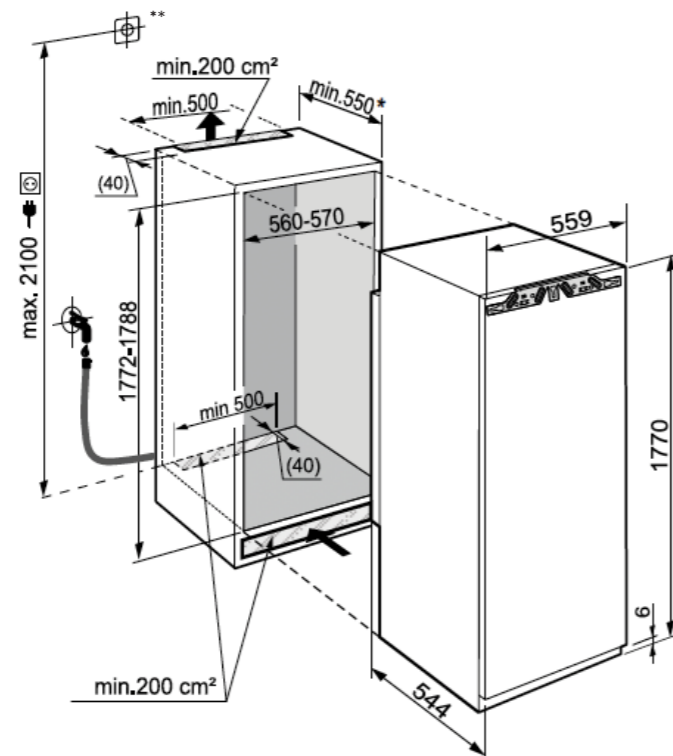

Generic product page: product images & features are for illustration purposes only. Model availability and specifications are subject to change without prior notice.

\*\*Recommended 560mm

**FiNFza 2224**  
Plus

Type	Fixed door / Built-in appliance for integrated use
Total volume	217
Aperture dimensions in cm (h / w / d)	177/55.9/54.4



**Controls**

- Type of control: MagicEye, key electronic Digital temperature display
- Door alarm: acoustic
- Alarm in case of malfunction: visual and acoustic

**Freezer compartment**

- Number of drawers: 8 drawers
- VarioSpace: yes
- Ice cube tray: yes

**Features**

- Side-by-Side concept: Side-panel heating on both sides, suitable for combination with other fridges, freezers and/or wine appliances
- Door hinges: Reversible door hinge
- EAN No. 4059303003467



MRP#  
**₹ 234,990**

#Price is subject to change without notice. Please get in touch with our sales representative/channel partner for the latest price update.

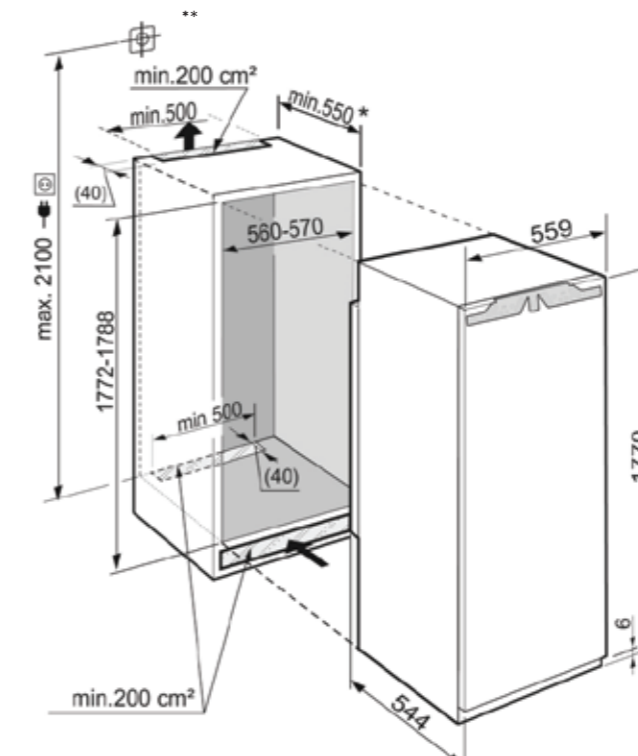

Generic product page: product images & features are for illustration purposes only. Model availability and specifications are subject to change without prior notice.

\*\*Recommended 560mm

## Technical Specifications



Images for representation purpose only, may vary from actuals.



**FIBFrC 3150**



**FIBFrC 3120**



**FiNFzA 2276**



**FiNFzA 2224**



**FiBBmA 2556**

Value Cluster	Plus	Prime	Prime
Refrigerator capacity litre (Total)	309	309	217
• Of which Fridge capacity litre (Total)	215	215	-
• Of which BioFresh comp. litre (Total)-	94	94	-
• Of which Freezer capacity litre (Total)	-	-	217
Total Glass Shelves	5	6	-
• Of which flat glass shelves	3	4	-
• Of which divisible glass shelves	2	2	-
Number of door racks	5	5	-
Number of freezer drawers	-	-	9
Number of BioFresh drawers	3	3	-
Number of BioCool drawers	-	-	-
Temperature display	Refrigerator compartment	Refrigerator compartment	Freezer compartment
Refrigerator temperature range °C	+3 °C to +9 °C	+3 °C to +9 °C	-
Freezer temperature range °C	-	-	-15 °C to -28°C
Climate Class	SN-T	SN-T	SN-T
Temperature alarm	Yes	Yes	Yes
Defrost type	Automatic	Automatic	Automatic
Interior light	Tower LED at both sides	LED light	LED light
Door alarm	Yes	Yes	Yes
Ice Maker	-	-	Fixed water connection 3/4"
Ice cube output kg/24h	-	-	0.8 kg/24 Hrs
SoftSystem	Yes	-	Yes
Voltage V	220-240 V ~	220-240 V ~	220-240 V ~
Product dimensions (h/w/d)	177 / 55.9 / 54.4 cm	177 / 55.9 / 54.4 cm	177 / 55.9 / 54.4 cm
• Internal Carcass Height	177.2 - 178.8 cm	177.2 - 178.8 cm	177.2 - 178.8 cm
• Internal Carcass Width	56 - 57 cm	56 - 57 cm	56 - 57 cm
• Internal Carcass Depth	55 - 56 cm	55 - 56 cm	55 - 56 cm

Value Cluster	Plus	Prime
Refrigerator capacity litre (Total)	217	249
• Of which Fridge capacity litre (Total)	-	111
• Of which BioFresh comp. litre (Total)-	-	70
• Of which Freezer capacity litre (Total)	217	68
Total Glass Shelves	-	3
• Of which flat glass shelves	-	2
• Of which divisible glass shelves	-	1
Number of door racks	-	2
Number of freezer drawers	8	3
Number of BioFresh drawers	-	2
Number of BioCool drawers	-	-
Temperature display	Freezer compartment	Refrigerator & Freezer compartment
Refrigerator temperature range °C	-	+3 °C to +9 °C
Freezer temperature range °C	-15 °C to -28°C	-14 °C to -26°C
Climate Class	SN-T	SN-T
Temperature alarm	Yes	Yes
Defrost type	Automatic	Automatic
Interior light	-	Tower LED light ar both sides
Door alarm	Yes	Yes
Ice Maker	-	-
Ice cube output kg/24h	-	-
SoftSystem	-	Yes
Voltage V	220-240 V ~	220-240 V ~
Product dimensions (h/w/d)	177 / 55.9 / 54.4 cm	177 / 55.9 / 54.4 cm
• Internal Carcass Height	177.2 - 178.8 cm	177.2 - 178.8 cm
• Internal Carcass Width	56 - 57 cm	56 - 57 cm
• Internal Carcass Depth	55 - 56 cm	55 - 56 cm

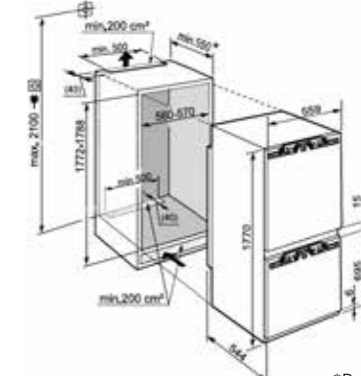
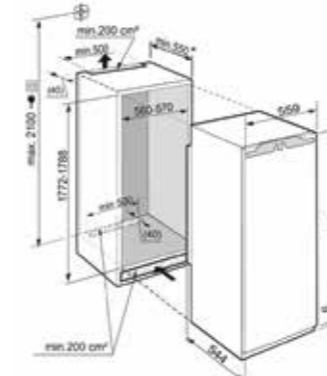
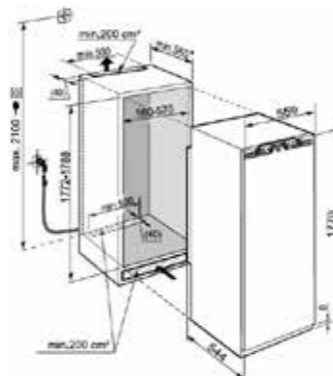
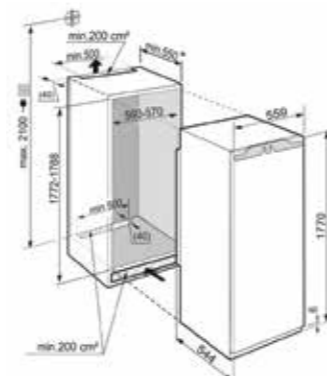
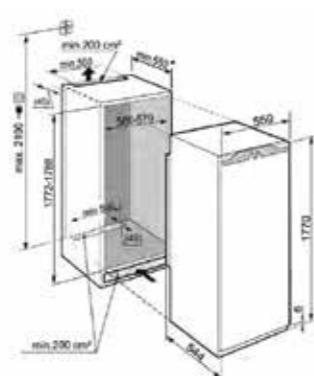

\*Recommended 560mm

\*Recommended 560mm



Bio Cool Duo Cooling No Frost  
**FINBmA 2714**

Bio Cool Duo Cooling No Frost Soft System  
**FINBmA 2756**

Value Cluster	Pure	Prime
Refrigerator capacity litre (Total)	263	263
• Of which Fridge capacity litre (Total)	195	195
• Of which BioFresh comp. litre (Total)-	-	-
• Of which Freezer capacity litre (Total)	68	68
Total Glass Shelves	5	5
• Of which flat glass shelves	3	3
• Of which divisible glass shelves	2	2
Number of door racks	3	3
Number of freezer drawers	3	3
Number of BioFresh drawers	-	-
Number of BioCool drawers	1	1
Temperature display	Refrigerator & Freezer compartment	Refrigerator & Freezer compartment
Refrigerator temperature range °C	+1 °C to +9 °C	+1 °C to +9 °C
Freezer temperature range °C	-14 °C to -26°C	-14 °C to -26°C
Climate Class	SN-T	SN-T
Temperature alarm	Yes	Yes
Defrost type	Automatic	Automatic
Interior light	LED light	Tower LED at left
Door alarm	Yes	Yes
Ice Maker	-	-
Ice cube output kg/24h	-	-
SoftSystem	-	Yes
Voltage V	220-240 V ~	220-240 V ~
Product dimensions (h/w/d)	177 / 55.9 / 54.4 cm	177 / 55.9 / 54.4 cm
• Internal Carcass Height	177.2 - 178.8 cm	177.2 - 178.8 cm
• Internal Carcass Width	56 - 57 cm	56 - 57 cm
• Internal Carcass Depth	55 - 56 cm	55 - 56 cm

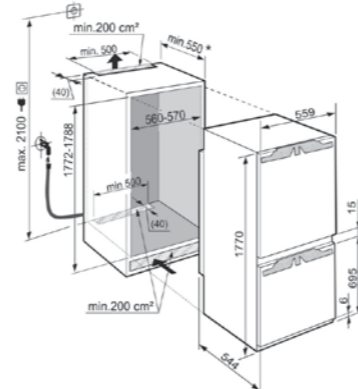
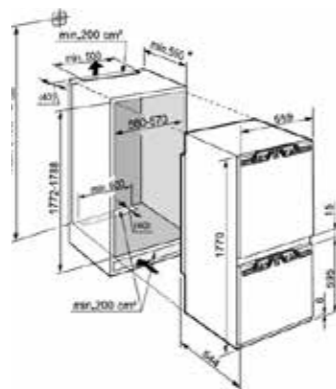

\*Recommended 560mm



Bio Cool Duo Cooling No Frost Soft System Ice Maker  
**FINBmA 2766**

Bio Fresh Duo Cooling No Frost Inverter Combi Soft System Soft System Ice Maker  
**FiBBmA 2566**

Value Cluster	Prime	Prime
Refrigerator capacity litre (Total)	263	249
• Of which Fridge capacity litre (Total)	195	111
• Of which BioFresh comp. litre (Total)-	-	70
• Of which Freezer capacity litre (Total)	68	68
Total Glass Shelves	4	3
• Of which flat glass shelves	3	2
• Of which divisible glass shelves	1	1
Number of door racks	3	2
Number of freezer drawers	4	4
Number of BioFresh drawers	-	2
Number of BioCool drawers	1	-
Temperature display	Refrigerator & Freezer compartment	Refrigerator & Freezer compartment
Refrigerator temperature range °C	+1 °C to +9 °C	+3 °C to +9 °C
Freezer temperature range °C	-14 °C to -26°C	-14 °C to -26°C
Climate Class	SN-T	SN-T
Temperature alarm	Yes	Yes
Defrost type	Automatic	Automatic
Interior light	Tower LED at left	Tower LED light at both sides
Door alarm	Yes	Yes
Ice Maker	Water Tank	Fixed water connection 3/4"
Ice cube output kg/24h	0.8 kg/24h	0.8 kg/24h
SoftSystem	Yes	Yes
Voltage V	220-240 V ~	220-240 V ~
Product dimensions (h/w/d)	177 / 55.9 / 54.4 cm	177 / 55.9 / 54.4 cm
• Internal Carcass Height	177.2 - 178.8 cm	177.2 - 178.8 mm
• Internal Carcass Width	56 - 57 cm	56 - 57 cm
• Internal Carcass Depth	55 - 56 cm	55 - 56 cm

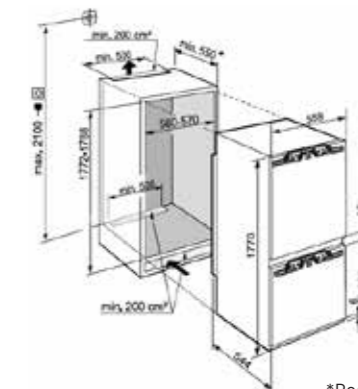
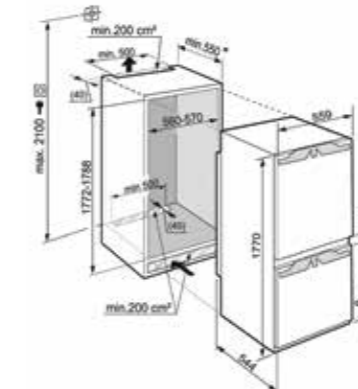

\*Recommended 560mm

**Best Possible  
Combinations**

Fridge \*

Freezer \*\*

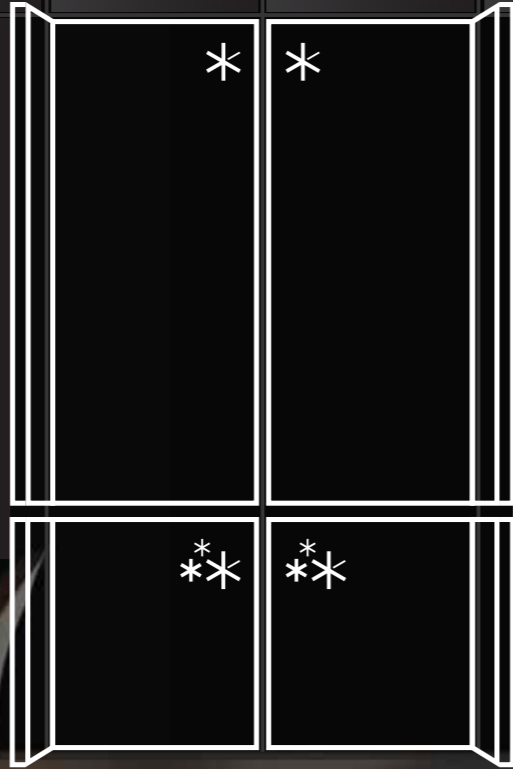

Fridge \*

Freezer \*\*

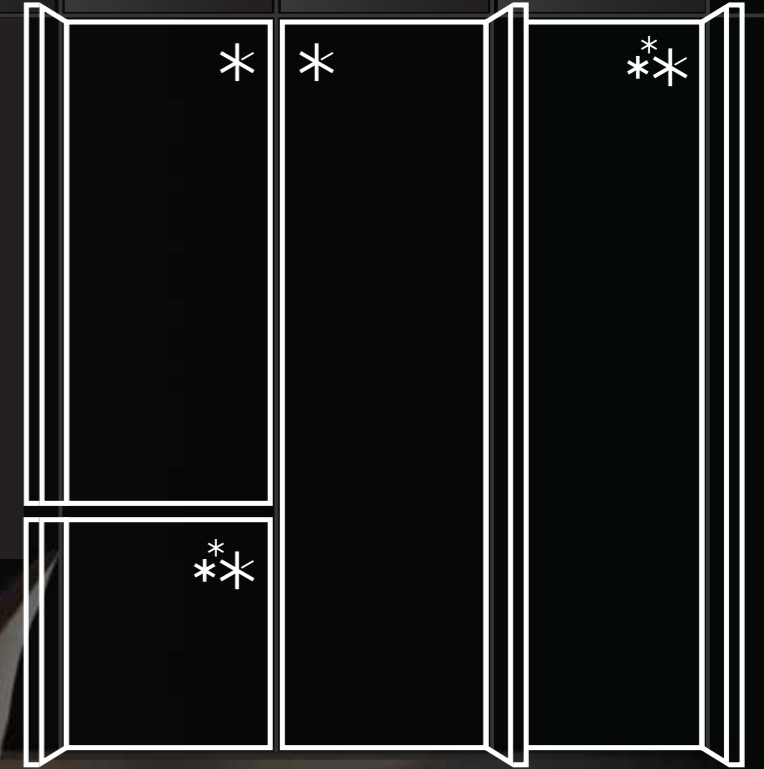

Fridge \*

Freezer \*\*

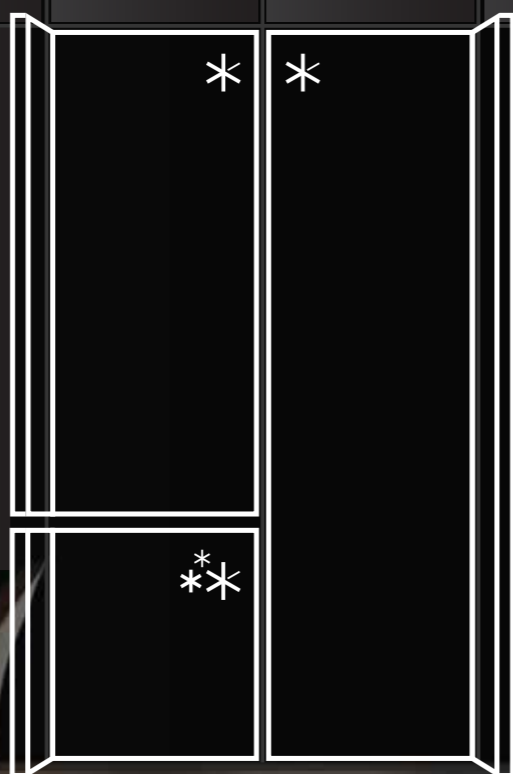

Fridge \*

Freezer \*\*

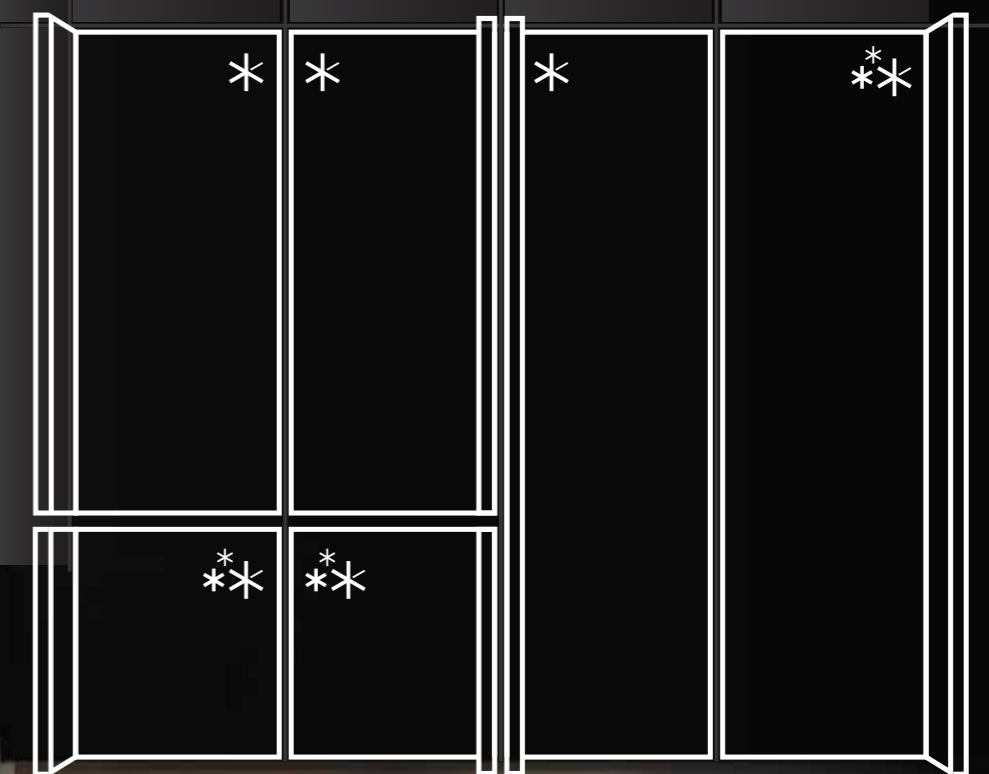

## Global Projects



### Moray House

Australia

A light wood colour palette crafts a luminous, inviting interior ambience. Luxurious curves indulge our senses, discreetly concealing our premium built-in cooling appliances while keeping the kitchen pristine and functional.

#### Featuring

- ICNh 5173 Built-in
- Fridge-FreezerSIKB 3550
- Built-in FridgeSIGN 3576
- Built-in FreezerCBNef 5735
- Freestanding Fridge-Freezer



## Global Projects



### Tembusu Grand

Singapore

Nestled within a lush, evergreen landscape with thematic gardens and cascading water features, Tembusu Grand exudes a unique stamp of quiet and understated elegance.

Its towering architecture takes inspiration from the Tembusu heritage tree, a true work of art which can only be complemented with a curated selection of our most coveted fridge-freezer models.

#### Featuring

ICNh 5173 Built-in

Fridge-FreezerSIKB 3550

Built-in FridgeSIGN 3576

Built-in FreezerCBNef 5735

Freestanding Fridge-Freezer

## Global Projects



### Meyer Mansion

Australia

Perched on the outskirts of the city, Meyer Mansion boasts an elevated vantage point adorned with full-length windows, designed to optimise the unobstructed sea view and its neighbouring enclave.

Exemplifying sophistication, the residences showcase seamlessly integrated cooling, freezing, and wine storage solutions to cater to your refined needs.

#### Featuring

CBNes 6256 Freestanding French Door Fridge-Freezer

SICN 3314 Built-in Fridge-Freezer

SUIK 1510 Undercounter Fridge

EWTdf 1653 Built-in Multi-Temperature Wine Cabinet

UWTes 1672 Undercounter Multi-Temperature Wine Cabinet



## Global Projects



### Midtown Suites

Singapore

A lavish mixed development located in the heart of Singapore, each residential unit boasts one of our fridge-freezers.

#### Featuring

SICN 3314 Built-in Fridge-Freezer



## Life in the Woods

Taiwan

Weave through the mountains and lush forests to unveil this hidden realm of bliss. Living up to its name, Life in the Woods offers a peerless sense of solitude, untouched by the bustle of urbanisation.

Integrated within the luxurious units of this courtyard-style residence are our German cooling appliances, ensuring your needs are covered as you enjoy a well-deserved respite.

### Featuring

SICN 3314 Built-in Fridge-Freezer

WUgb 3400 Undercounter  
Wine Cabinet

## Global Projects

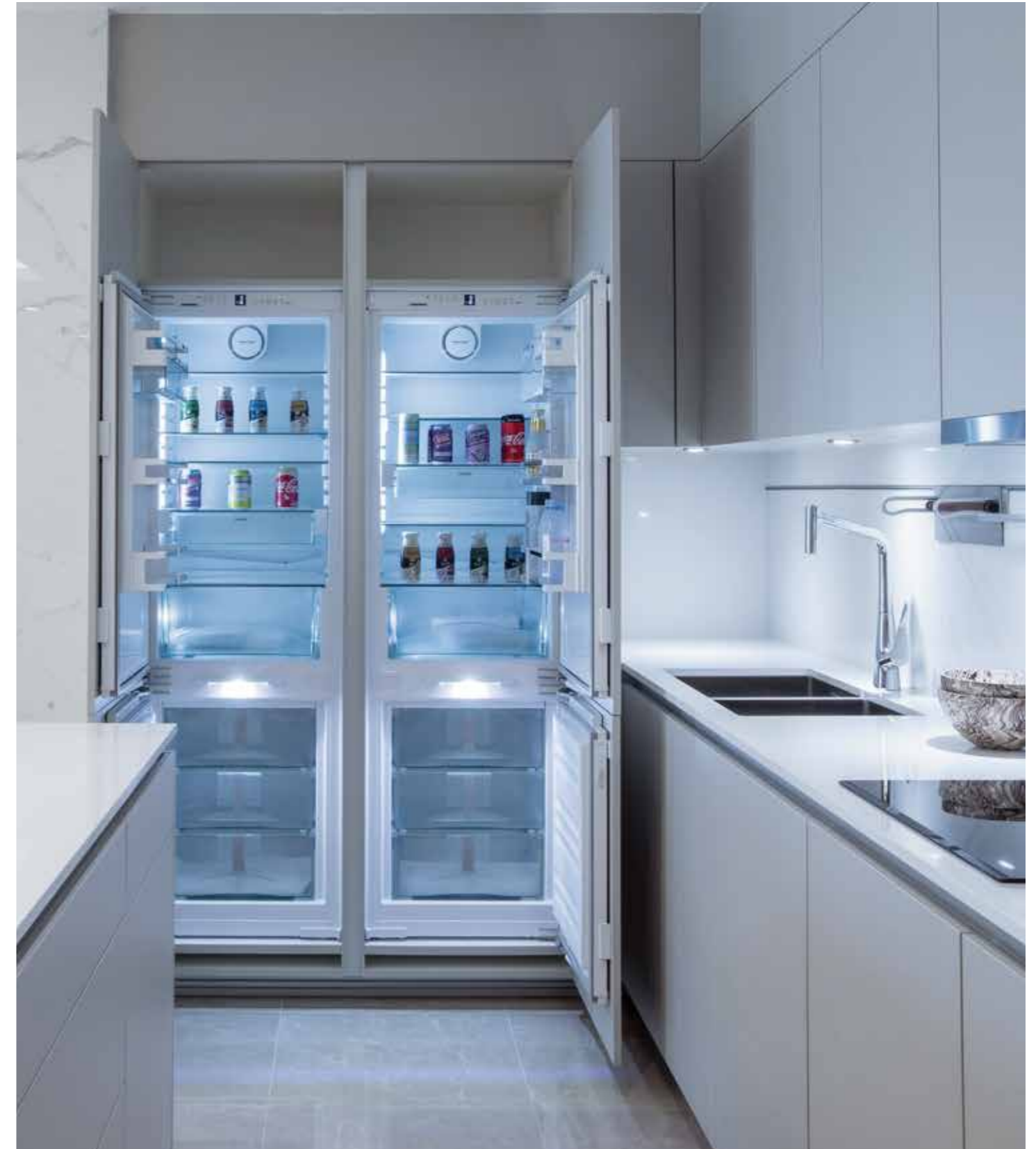

### The Residences at Sindhorn Kempinski

Thailand

Redefining standards for unique cosmopolitan living in the heart of Bangkok, the spotlessly white residential units feature premium German cooling appliances for that extra touch of indulgence.

#### Featuring

SICN 3356 Built-in Fridge-Freezer

UWKes 1752 Undercounter  
Wine Cabinet

## Global Projects

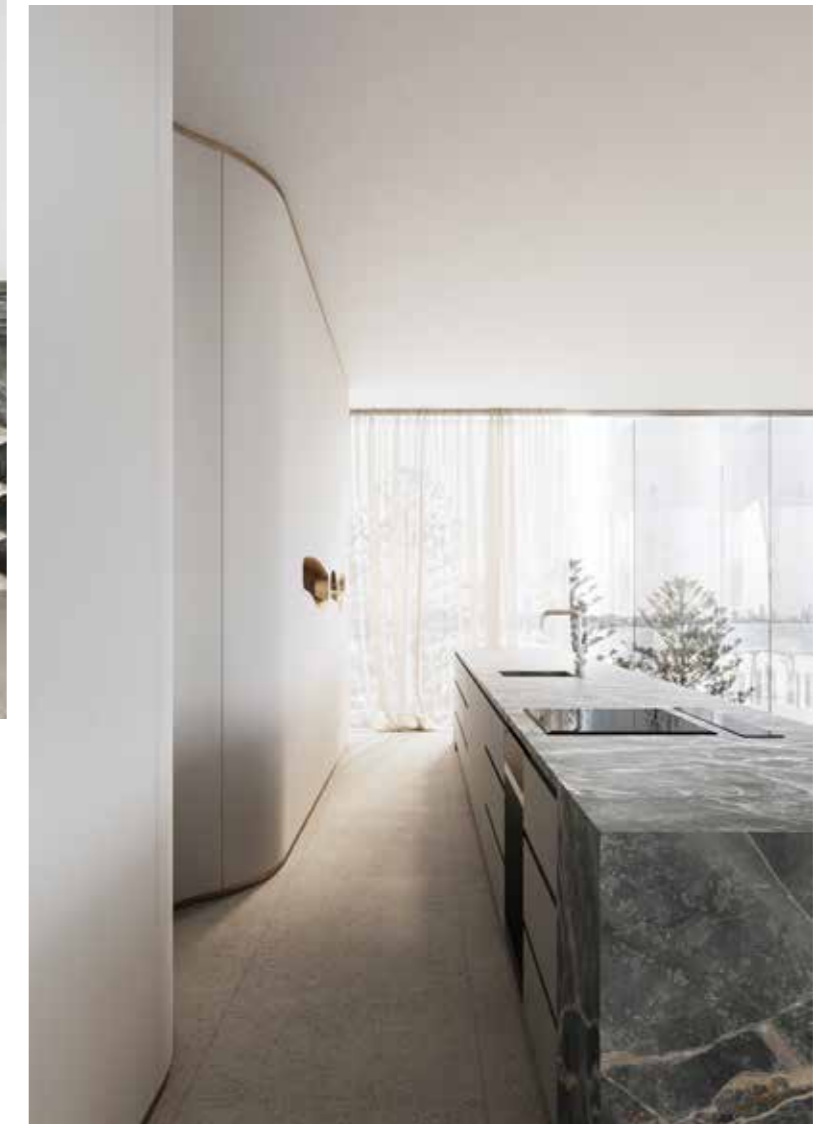

### Glasshouse

Australia

The Glasshouse Burleigh. Take a breath of fresh air as you bask in the dreamy splendour of its architecture and the serenity of your surroundings. Step back into a sophistication of white and pale gold elements with our coveted built-in fridge-freezer housed within, complemented with stone and marble features.

#### Featuring

ECBN 5066 Built-in Fridge-Freezer  
ICBNh 5173 Built-in Fridge-Freezer



Scan this QR code or visit the following link  
to access our social media channels:  
[socialmedia.home.liebherr.com](https://socialmedia.home.liebherr.com)



FreshMAG - Discover the world of Liebherr Appliances with  
the latest interesting news, stories, valuable tips and tricks  
on food storage, recipes and lots more besides!

### Liebherr Appliances India Pvt. Ltd.

A-1/6, Shendra MIDC, Chhatrapati Sambhaji Nagar, Maharashtra - 431 154, India. E-mail: [customercare.lhi@liebherr.com](mailto:customercare.lhi@liebherr.com)  
To find out more or to get information on where you can buy a Liebherr product, Call Customer Care at: 7038 100 400

Your local Liebherr authorised dealer will help you make the right choice of refrigerators to suit your lifestyle.

Due to continuous R&D at Liebherr, the design and specifications may change without prior notice. Technology, features, sizes and specifications may differ from model to model. Colours shown in the catalogue and the colours of actual products may slightly vary due to printing restrictions. Foodstuffs and bottles shown in the catalogue are for illustration purposes only. Any resemblance or closeness to any brand/trademark is a coincidence and totally unintentional. Terms & Conditions apply.

Jan'26

[home.liebherr.com](https://home.liebherr.com)



Subject to modification. Current data see [home.liebherr.com](https://home.liebherr.com).