

EN-US

# H 6, H 10, H 15

Hydraulic hammer  
[www.liebherr.com](http://www.liebherr.com)

# LIEBHERR

Deep foundation machines

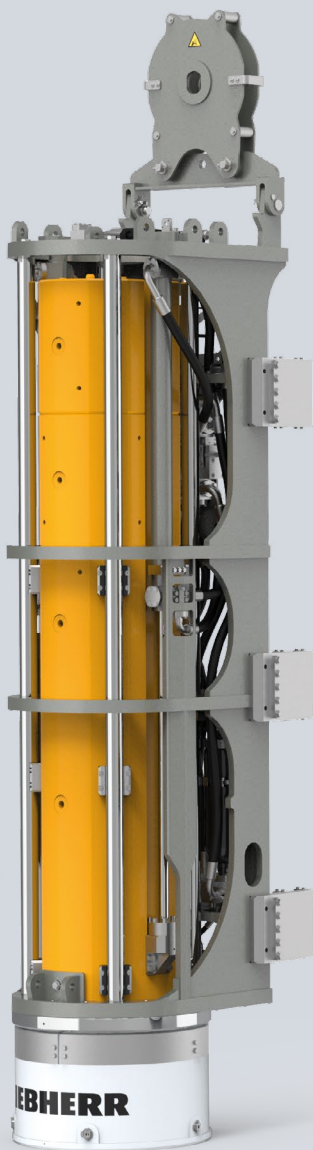

# Hydraulic hammer H 6

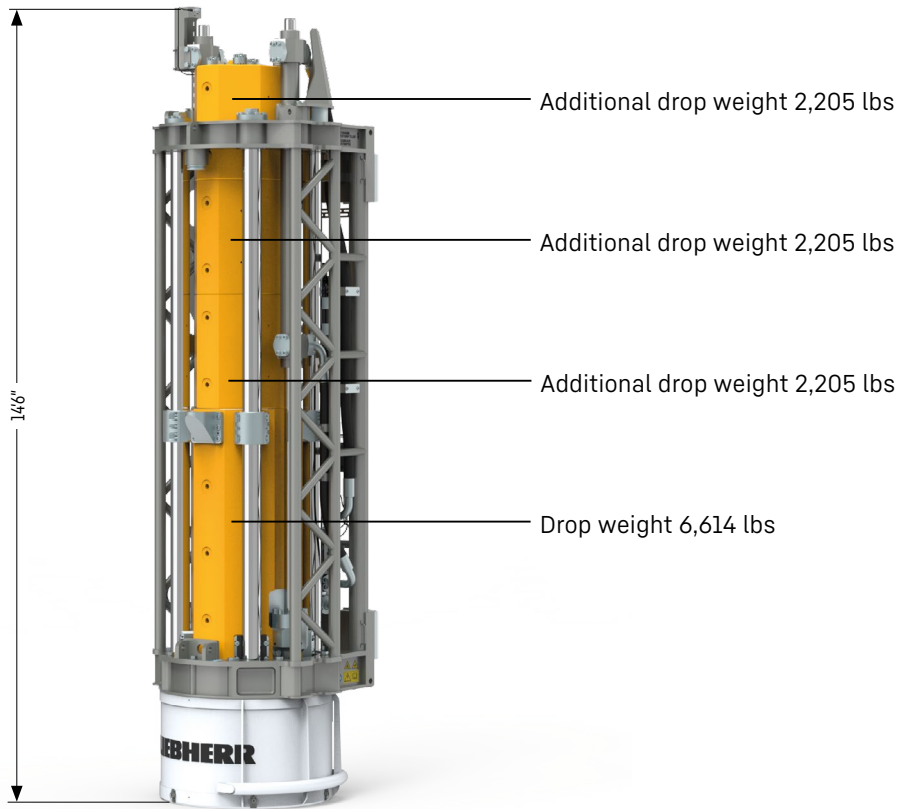

## Technical data H 6

Hammer type		H 6-3	H 6-4	H 6-5	H 6-6
Drop weight	lbs	6,614	8,818	11,023	13,228
Max. rated energy	lbf-ft	26,552	35,403	44,254	53,104
Blow rate - blows/min		50-150	50-150	50-150	40-150
Hammer weight incl. pile helmet and dolly	lbs	14,771	16,976	19,180	21,385
Drop height	ft	3.9	3.9	3.9	3.9
Inclination		1:3	1:3	1:3	1:3

Various pile helmet sizes available on request

Soundproofing is standard

The modular weights are interchangeable.

Requirement for stand-alone hammer control: 66 gal/min at 4786 PSI

# Hydraulic hammer H 10

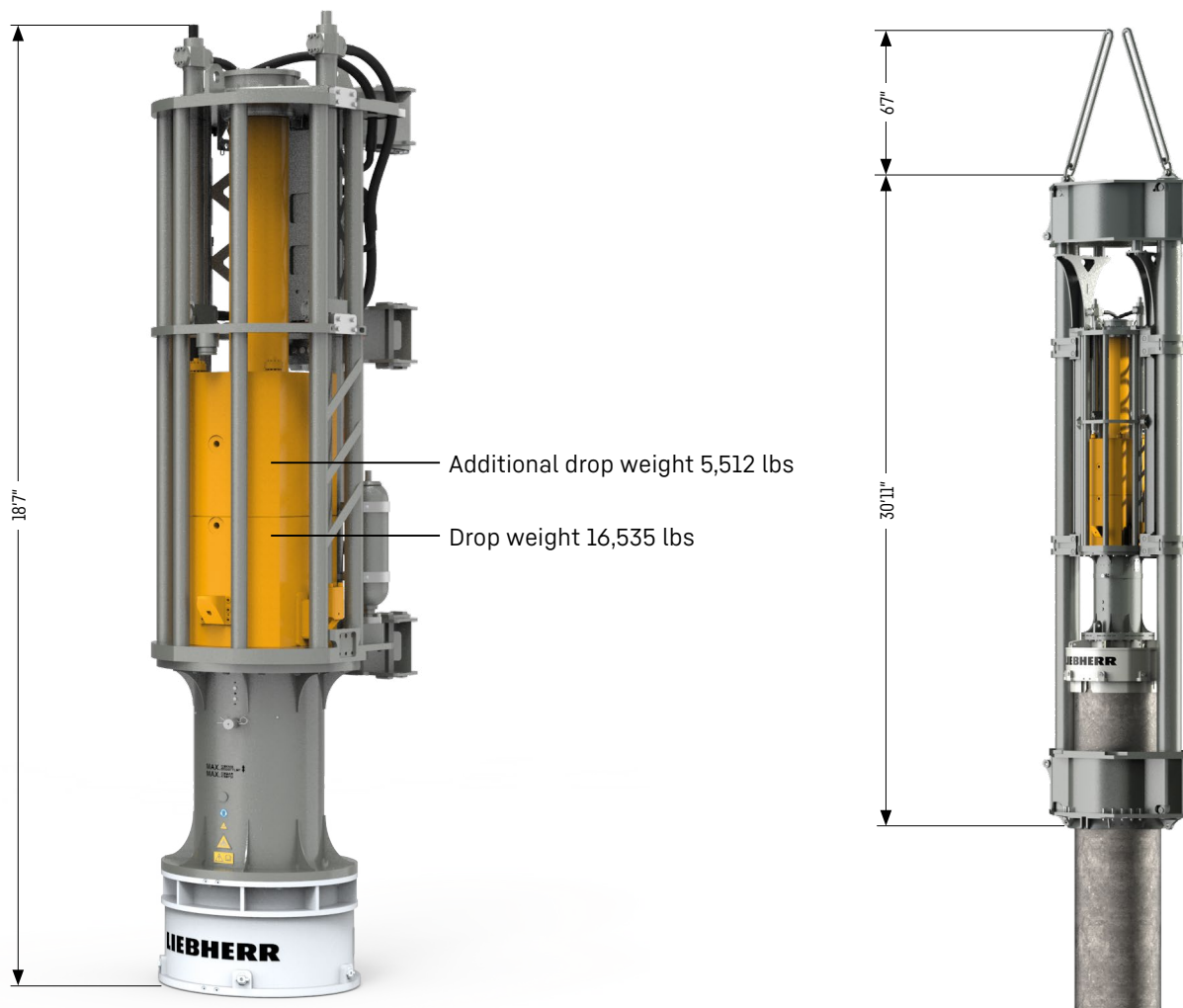

## Technical data H 10

Hammer type		H 10-75	H 10-100	free-hanging
Drop weight	lbs	16,535	22,046	-
Max. rated energy	lbf-ft	66,381	88,507	-
Blow rate - blows/min		50-150	50-150	-
Hammer weight incl. pile helmet and dolly	lbs	30,203	35,715	-
Hammer weight (free-hanging) cpl.	lbs	47,400	52,910	18,740
Max. pipe diameter	ft	-	-	4.0
Drop height	ft	3.9	3.9	3.9
Inclination		1:1	1:1	1:3

Various pile helmet sizes available on request

Soundproofing is standard

Requirement for stand-alone hammer control: 103 gal/min at 4786 PSI

# Hydraulic hammer H 15

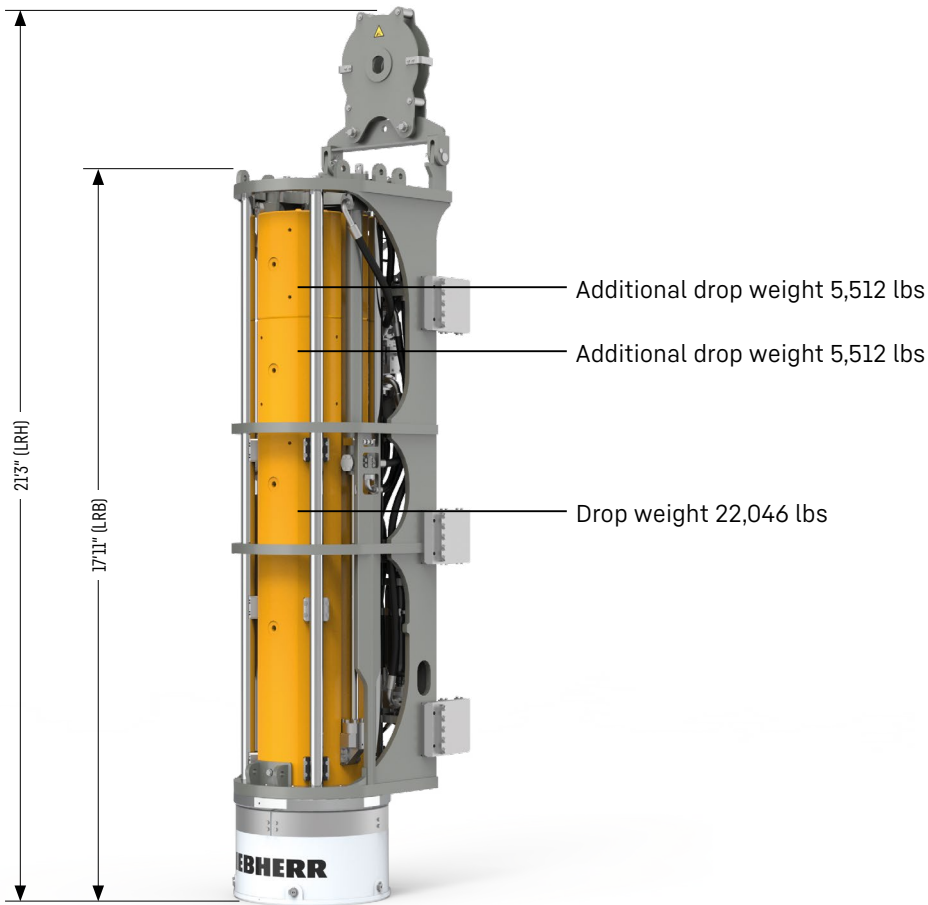

## Technical data H 15

Hammer type		H 15-10	H 15-12	H 15-15
Drop weight	lbs	22,046	27,558	33,069
Max. rated energy	lbf-ft	110,634	138,662	165,951
Blow rate - blows/min		30-80	30-80	30-80
Hammer weight incl. pile helmet and dolly	lbs	41,447	46,958	52,470
Drop height	ft	4.9	4.9	4.9
Inclination		1:3	1:3	1:3

Various pile helmet sizes available on request

Soundproofing is standard

The modular weights are interchangeable.

Requirement for stand-alone hammer control: 169 gal/min at 4786 PSI

Liebherr-Werk Nenzing GmbH · Dr. Hans Liebherr Str. 1 · 6710 Nenzing, Austria  
 Phone +43 50809 41-473 · crawler.crane@liebherr.com · www.liebherr.com  
 facebook.com/LiebherrConstruction