

EN-US

---

# HS 8100.2

---

HS 8004.03.03  
[www.liebherr.com](http://www.liebherr.com)

## LIEBHERR

Construction machines



# Concept and characteristics

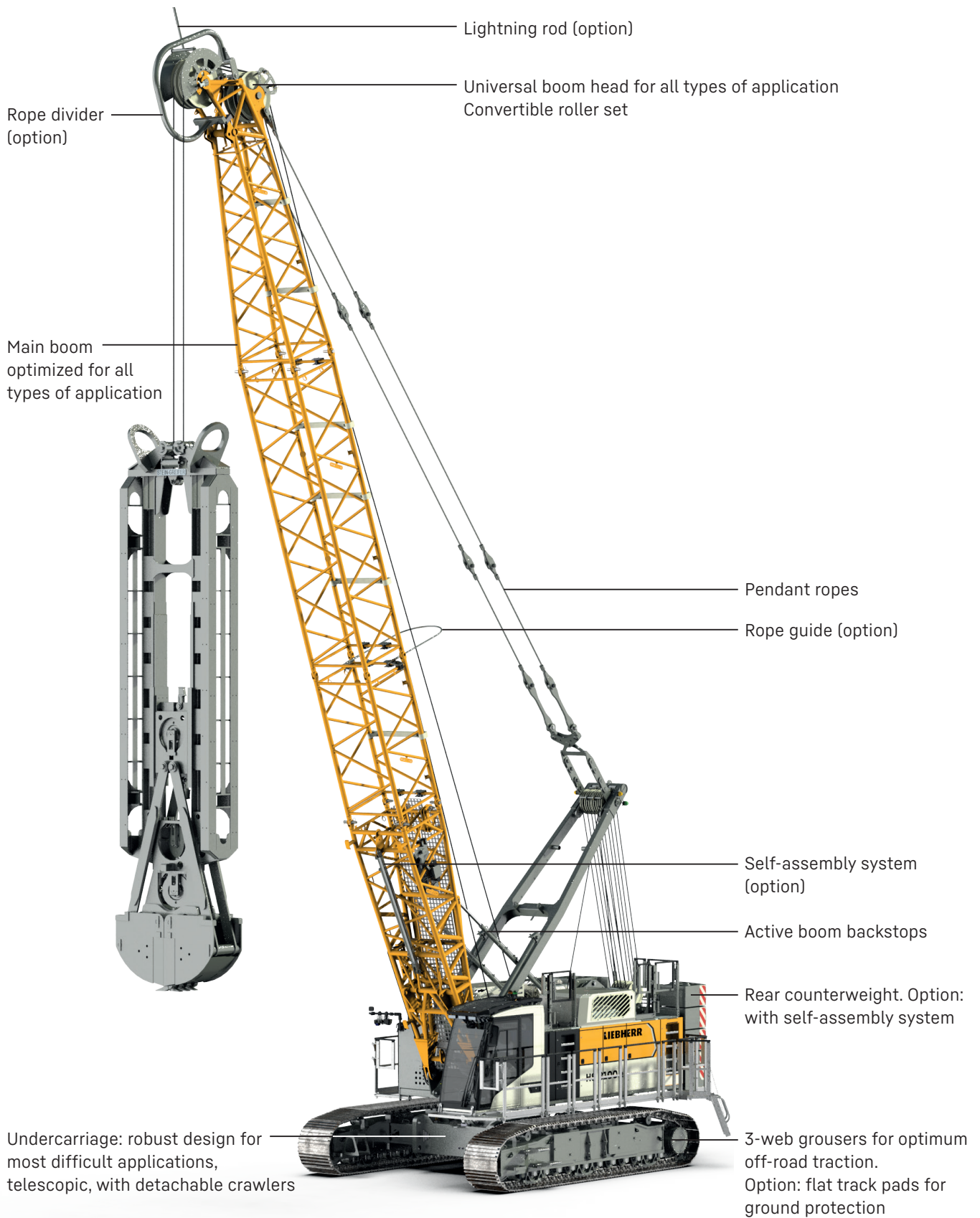

## Operating comfort



### **The newly developed cabin combines operator comfort with easy handling.**

Air conditioning combined with an air-suspended seat offers an ideal workplace for the operator.

- Front pane, roof pane and right-hand side pane, armoured glass as a standard
- Completely new cabin design focusing on ergonomics and operating comfort
- Improved soundproofing
- Orthopaedic seat, heatable, coolable and ventilated
- Individually adjustable monitors
- Charger for mobile devices
- Heated outside mirror

### **Eco-silent package**

- Eco-silent mode  
With the aid of this feature, which is mainly used in dragline operation, the engine speed is reduced to a required predefined level. This also reduces noise emission.
- Automatic engine stop control  
This control system switches the engine off automatically during longer idling periods, after having checked certain system functions. This reduces the operating hours of the machine and at the same time extends the service intervals, which leads to a reduction in operating costs.
- Lower engine speed while idling  
Construction machines are in idling mode for 45 % of their operating time. With the lowering of the engine speed from 950 rpm to 750 rpm while the machine is in idling mode, up to 0,5 gal of fuel can be saved per hour.

# Maintenance

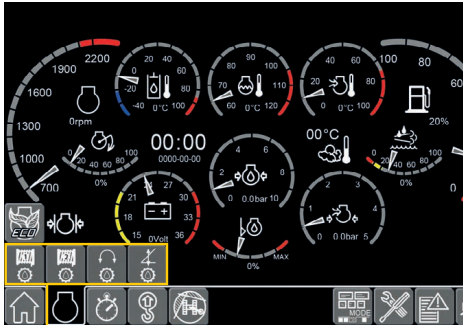

## Gear oil level warning

The new warning allows the operator to check the gear oil levels of both main winches, the swing drive and the luffing winch. This facilitates daily maintenance of the machine.

### Example



Gear oil level warning of winch 1 lights up green: Gear oil level of winch 1 is sufficient.



Gear oil level warning of winch 1 lights up yellow after ten seconds: Fill gear oil for winch 1.



## Ground pressure visualisation



## Refuelling

Thanks to a new concept, refuelling is no longer carried out via the roof of the uppercarriage but via the walkway with easy and safe access.

A refuelling pump is available as an option – for both diesel and urea.

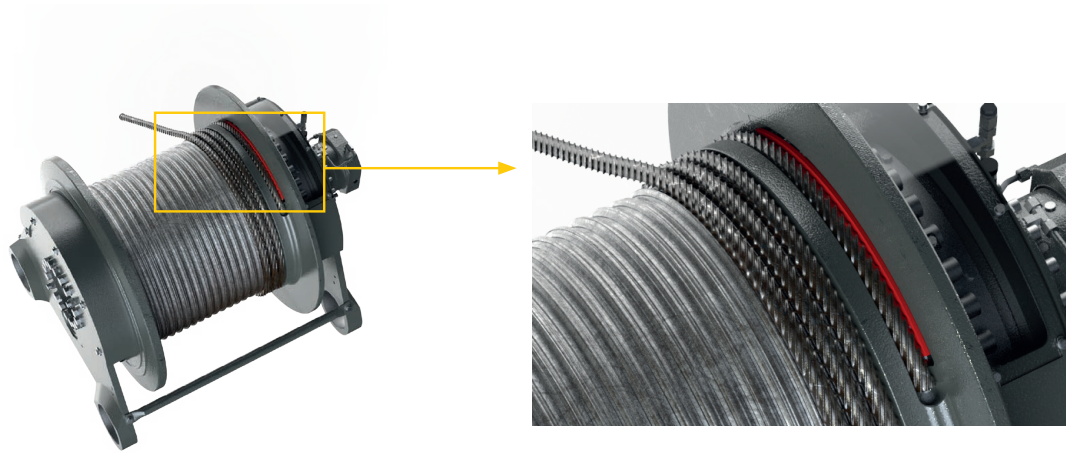

### **Rope lock**

The 66,319 lbf winches are equipped with a new rope lock. This means that the ropes can be replaced more quickly and more easily, which reduces downtime.

A rope-reeving winch is available as an option, which makes changing the rope even easier. There is also a rope tensioning pulley for slurry wall grab operation.

A radio remote control is available for safe rope changes.

# Technical description



## Operating weights

<b>Composition of operating weight</b>	The operating weight includes the basic machine with HD undercarriage, 2 main winches 66,319 lbf including wire ropes (295 ft) and 36 ft main boom, consisting of A-frame, boom foot (18 ft) and boom head (18 ft), 57,982 lbs rear counterweight, 2.6 ft 3-web grousers and 132,277 lbs hook block
<b>Total weight</b>	approx. 197,000 lbs

## Ground pressure

<b>Ground pressure</b>	14.8 PSI
------------------------	----------

## Equipment

<b>Main boom (1311.24)</b>	lifting operation	max. 194 ft
	with fixed jib	max. 125 ft
	duty cycle operation	max. 105 ft

## Diesel engine

<b>Power rating according to ISO 9249</b>	450 kW (603 hp) at 1700 rpm
<b>Engine type</b>	Liebherr D 966 A7-05
<b>Fuel tank capacity</b>	209 gal with continuous level indicator and reserve warning
<b>AdBlue tank capacity</b>	21 gal with continuous level indicator and reserve warning
<b>Exhaust certification</b>	97/68 EC Stage IV; EPA/CARB Tier 4f 97/68 EC Stage V; EPA/CARB Tier 4f

## Noise measurement data and vibration

<b>Noise emission</b>	according to 2000/14/EC directive
<b>Emission sound pressure level <math>L_{PA}</math></b>	74 dB(A) (in the cabin)
<b>Guaranteed sound power level <math>L_{WA}</math></b>	109 dB(A) (of the machine)
<b>Vibration transmitted to the machine operator</b>	< 8.2 ft/s <sup>2</sup> (to the hand-arm system) < 1.6 ft/s <sup>2</sup> (to the whole body)

## Hydraulic system

<b>Hydraulic pumps</b>	variable pumps in closed and open circuits supplying oil only when needed (flow control on demand)
<b>Hydraulic oil tank capacity</b>	227 gal
<b>Max. working pressure</b>	5,800 PSI
<b>Max. power at the connection plate</b>	402 hp (2x 81 gal/min) for external appliances
<b>Hydraulic oil</b>	electronic monitoring of all filters use of synthetic environmentally friendly oil possible
<b>Hydraulic retrofit kits for attachments</b>	ready-made customized hydraulic retrofit kits are available e.g. powering casing oscillators, vibrators, hydraulic grabs, fixed leaders

## Hoisting gear

<b>Main winches</b>	pressure controlled, variable flow hydraulic motors for the drag and hoist winches, full utilisation of engine power as the winch speed is automatically adjusted to suit the respective line pull Free fall: clutch and braking functions are provided by the service brake (low wear and maintenance-free multi-disc brake in compact design)
<b>Winch options</b>	
Line pull in the 1st layer	66,319 lbf
Rope diameter	34 mm
Drum diameter	2.5 ft
Rope speed	0-315 ft/min
Rope capacity in the 1st layer	116 ft*
Rope capacity in the 3rd layer	462 ft*
	* effective length
<b>Options</b>	
Auxiliary winch	15,737 lbf in boom foot
Tagline winch	6,744 lbf with free fall

## Boom winch

<b>Line pull</b>	max. 23,605 lbf
<b>Rope diameter</b>	20 mm
<b>Boom luffing</b>	15-84° in 44 s

## Crawlers

<b>Drive system</b>	with fixed axial piston hydraulic motors
<b>Crawler side frames</b>	maintenance-free, with hydraulic chain tensioning device
<b>Brake</b>	hydraulically released, spring-loaded multi-disc holding brake
<b>Drive speed</b>	0-0.8 mph
<b>Grousers</b>	3-web grousers, width 2.6 ft
<b>Width of undercarriage</b>	automatic track width adjustment from transport width to operating width via hydraulic cylinders
<b>Options</b>	self-assembly system, jack-up system 3-web grousers, width 3 ft flat track pads, width 3 ft 3-web grousers, width 3.3 ft

## Swing gear

<b>Drive system</b>	with fixed axial piston hydraulic motors, planetary gearbox, pinion
<b>Swing ring</b>	roller bearing with external teeth
<b>Brake</b>	hydraulically released, spring-loaded multi-disc holding brake
<b>Swing speed</b>	0-4 rpm continuously variable, selector for 3 speed ranges to increase swing precision
<b>Lubrication system</b>	automatic central lubrication system reduces maintenance requirements and increases service life
<b>Option</b>	display of swing angle second swing drive

## Control

<b>Control</b>	includes all control and monitoring functions, designed to withstand extreme environmental conditions and heavy duty construction tasks
<b>Display</b>	high resolution monitor in the operator's cabin, clear display of complete machine operating data, warnings and failure indications in the required language
<b>Operation</b>	several movements can be performed simultaneously thanks to electro-hydraulic proportional control, all categories of loads can be positioned with utmost precision
<b>Options</b>	PDE*: process data recording LiTU: Liebherr Telematics Unit

# Dimensions

## Basic machine with undercarriage

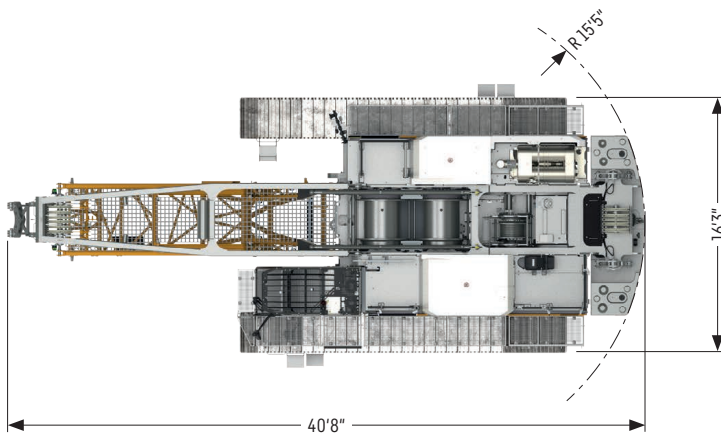
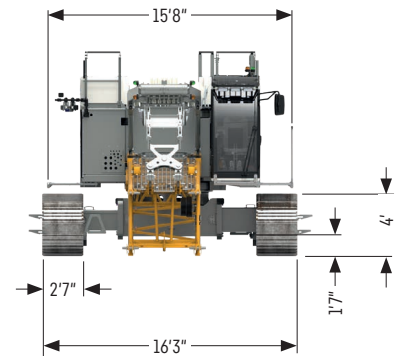
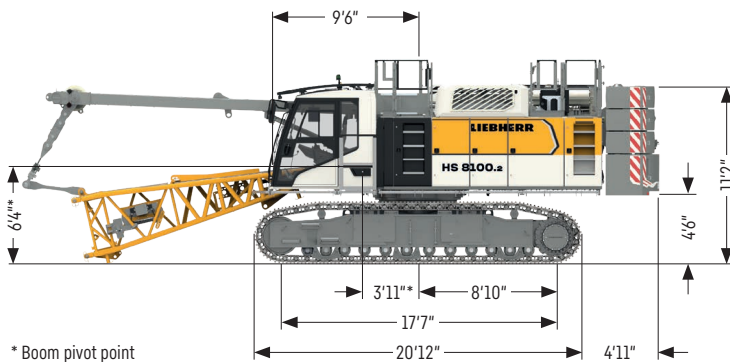

### Remarks

- Liebherr cable excavator HS 8004.02.04
- Designed according to EN 474-1 and EN 474-12.
- Machine is standing on firm, horizontal ground.
- The weight of the lifting device (pulley block, hoist ropes, shackles etc.) must be deducted from the load capacity.
- Additional equipment on boom (e.g. walkways) must be deducted from the lifting capacity.
- For max. wind speed please refer to lift chart in operator's cab or manual.
- Working radii are measured from centre of swing and under load.
- The lifting capacities are valid for 360 degrees of swing.
- The last digits of the given dimensions are rounded to 0 and 5 and may differ from the actual dimensions.
- Weights may vary depending on the delivered configuration of the machine filling level of the tanks as well as generally valid tolerances.
- The figures in this brochure may include options which are not within the standard scope of supply of the machine.



# Grab versions

## Assistance system

### GrabMatic

- Grab visualisation  
The status of the grab (open, closed) is shown on the display.
- Slack rope automatic  
When positioning the grab, it is possible that slack rope occurs. This is counteracted by the control system.
- Level cutting  
This function allows the dredging of a level surface under water to a specified depth.
- Automatic winch synchronisation  
Thanks to the automatic winch synchronisation, lifting and lowering is possible with just one control lever.
- Grab filling level  
Automatic hoisting and lowering of the grab during dredging enables an optimum filling level of the grab.
- Cycle counter  
The number of work cycles is shown on the display.

### Dredging interface

The interface allows the integration of different systems with which, for example, the swell compensation can be implemented.





### Casing oscillator

Max. drilling diameter	ft 6.6
------------------------	--------



### HS 8100.2 on pedestal

Power rating of diesel engine	kW 450
Free-fall winches	lbf 2x 44,092 or 2x 66,319
<b>Option:</b>	
Cabin elevation, fixed	ft 7.5
Cabin elevation, variable, hydraulic	ft 9

### GrabMatic (option)



### Further information on material handling



# Capacities in grab operation

## Capacities in [1000 lbs] with 58,000 lbs counterweight

	Boom length [ft]							
	36	46	56	66	75	85	95	105
14.3				100.2				
15	100.2	100.2	100.2	100.2				
20	100.2	100.2	100.2	100.2	100.2	92.6	83.8	70.6
25	79.7	79.9	80.0	80.0	80.0	79.9	79.8	70.6
30	61.2	61.5	61.6	61.5	61.4	61.3	61.2	61.0
35	49.3	49.6	49.7	49.6	49.5	49.4	49.2	49.0
40	40.8	41.3	41.4	41.3	41.2	41.0	40.9	40.7
45		35.1	35.2	35.2	35.1	34.9	34.7	34.5
50		30.2	30.5	30.4	30.4	30.2	30.0	29.8
55			26.7	26.7	26.6	26.4	26.2	26.0
60				23.6	23.6	23.4	23.2	23.0
65				21.0	21.0	20.9	20.7	20.5
70					18.9	18.7	18.6	18.3
75					17.0	16.9	16.7	16.5
80						15.3	15.2	14.9
85						13.9	13.8	13.6
90							12.5	12.3
95							11.4	11.2
100								10.3
105								9.4

TLT 13649087 0 Preliminary\_5. Stability calculated according to EN 474-12. Max. capacities do not exceed 66 % of tipping load.

Above capacities are for reference only and are not programmed in the LML system.

When working with a mechanical 2-rope grab the total load to be lifted is limited by the line pull of one winch.

Max. main boom 105 ft

Max. lifting capacity with mechanical grab is 66,139 lbs. For higher lifting capacities a hydraulic grab is required.

# Slurry wall grab

## Maximum capacity in duty cycle operation with standard ropes

Line pull (1st layer)	lbf	66,319
Rope diameter	mm	34
Minimum breaking load	lbf	235,150
Line pull - 1-rope duty cycle operation	lbf	66,319
Line pull - 2-rope duty cycle operation <sup>1)</sup>	lbf	100,490

1) Lifting a load exceeding the line pull of one winch is only allowed if it can be ensured that each individual winch is not overloaded.  
 When working with a mechanical 2-rope grab the total load to be lifted is limited by the line pull of one winch.  
 Rigging and ropes are part of the load.

Capacities in slurry wall operation are for reference only and are not programmed in the LML system.  
 All loads and counterweight configurations are max. values and must not be exceeded.  
 Weight of additional equipment on boom (e.g. walkways, hose drums etc.) must be deducted to get the net capacity.



# Load chart for slurry wall operation

## Capacities in [1000 lbs] with 58,000 lbs counterweight

Radius [ft]	Boom length [ft]					
	56	66	75	85	95	105
15	97.4	97.4				
20	97.4	97.4	97.4	88.9	80.4	67.7
25	69.8	69.8	69.8	69.7	69.6	67.7
30	53.7	53.7	53.6	53.5	53.4	53.3
35	43.4	43.3	43.2	43.1	42.9	42.8
40	36.1	36.0	36.0	35.8	35.7	35.5
45	30.8	30.7	30.6	30.4	30.3	30.1
50	26.6	26.6	26.5	26.3	26.2	26.0
55	23.3	23.3	23.2	23.1	22.9	22.7
60		20.6	20.6	20.4	20.3	20.1
65		18.4	18.4	18.2	18.0	17.9
70			16.5	16.3	16.2	16.0
75			14.9	14.7	14.6	14.4
80				13.4	13.2	13.0
85				12.1	12.0	11.8
90					11.0	10.8
95					10.0	9.8
100						9.0
105						8.2

14153212 0 Preliminary\_20. Max. main boom 105 ft.

Machine is standing on firm, horizontal ground.

The load capacities do not exceed the stability requirements of EN 16228-5.



For further information please refer to the HSG 5-18 datasheet.

### Short boom

Rope diameter	mm	34
Radius	ft	20 at max. boom angle 28.3° 16.7 at min. boom angle 51.4°
Machine height during operation (max.)	ft	27.7 at max. boom angle 28.3°
(min.)		19.3 at min. boom angle 51.4°
Effective rope length	ft	127
Rear counterweight	lbs	51,368
Capacity in duty cycle operation	lbs	83,555 at radius of 16 ft 74,075 at radius of 20 ft

Machine is standing on firm, horizontal ground.

The load capacities do not exceed the stability requirements of EN 16228-5.

# Dynamic soil compaction

## Soil compaction control

The soil compaction control makes working with dynamic compaction easier and offers the operator more protection. They can use the system to enter the number of blows per point. The process is documented in the PDE and can be analysed using various systems.

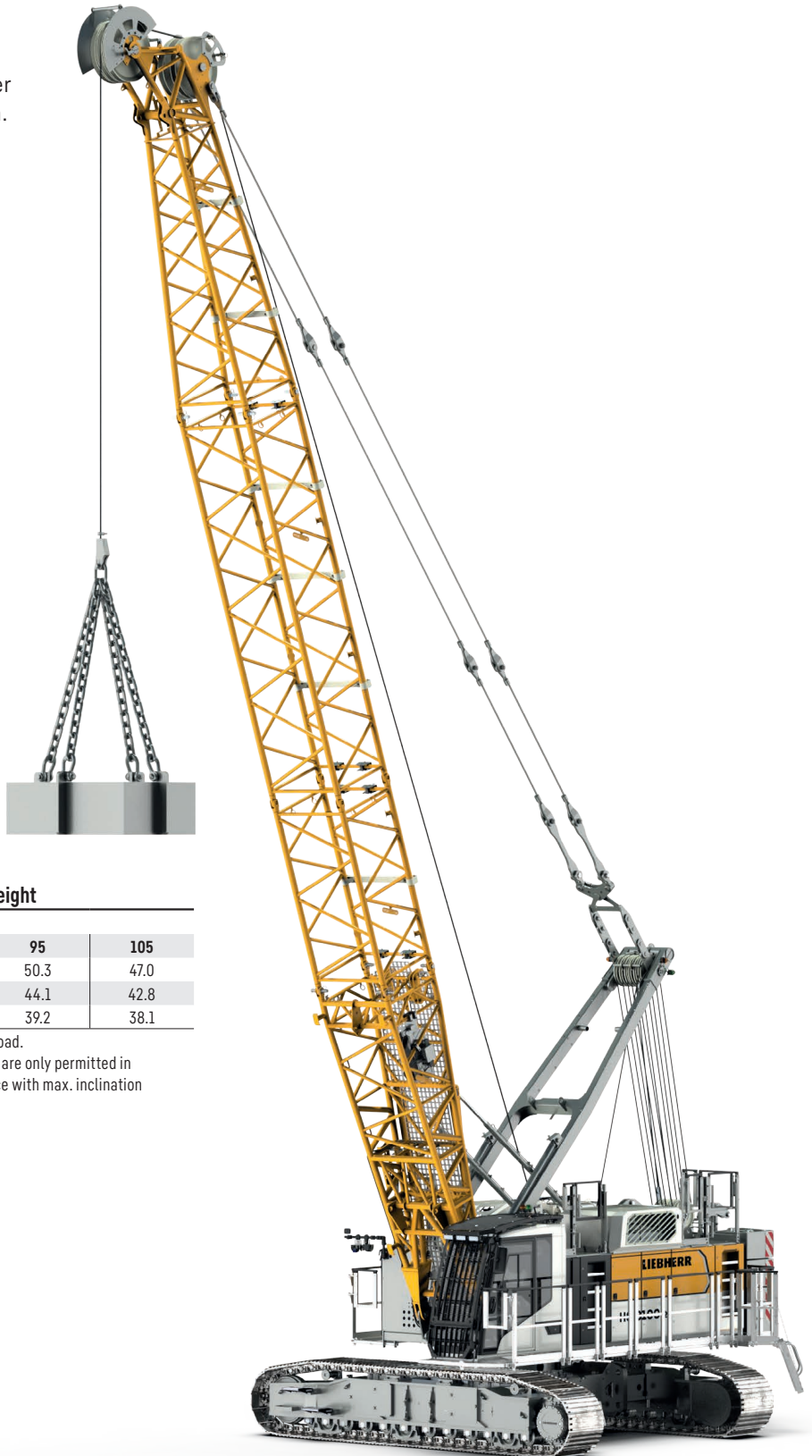

Capacities in [1000 lbs] with 58.000 lbs counterweight

Radius [ft]	Boom length [ft]				
	66	76	85	95	105
26	55.0	53.8	52.0	50.3	47.0
30	46.4	46.3	45.6	44.1	42.8
33		40.0	39.8	39.2	38.1

Max. capacities in metric tonnes do not exceed 75 % of tipping load.  
 All loads given are max. values and must not be exceeded. They are only permitted in two-rope automatic operation and are valid for work on a surface with max. inclination of 1 %. Lifting heights must not exceed 82 ft.  
 Option: Piling control incl. cabin protection and armoured glass  
 Max. main boom 105 ft

# Special applications

- Vibro-flot (deep vibrator)
- Hammer
- Vibrator (free-hanging)
- Shaft excavation
- Rock handling
- Magnet system
- Demolition (longer main booms available on request)

## Capacities in [1000 lbs] with 58,000 lbs counterweight

	Boom length [ft]							
	36	46	56	66	75	85	95	105
14,3				100.2				
15	100.2	100.2	100.2	100.2				
20	100.2	100.2	100.2	100.2	100.2	92.6	83.8	70.6
25	90.6	90.8	90.9	90.9	87.7	84.7	81.8	70.6
30	69.6	69.9	70.0	69.9	69.8	69.0	66.9	64.9
35	56.0	56.4	56.4	56.4	56.2	56.1	55.9	54.6
40	46.4	46.9	47.0	46.9	46.8	46.6	46.4	46.2
45		39.8	40.0	40.0	39.8	39.6	39.4	39.2
50		34.3	34.7	34.6	34.5	34.3	34.1	33.8
55			30.4	30.3	30.2	30.0	29.8	29.6
60				26.8	26.8	26.6	26.4	26.1
65				23.9	23.9	23.7	23.5	23.2
70					21.5	21.3	21.1	20.8
75					19.3	19.2	19.0	18.8
80						17.4	17.2	17.0
85						15.8	15.6	15.4
90							14.2	14.0
95							13.0	12.8
100								11.7
105								10.6

TLT 13649087 0 Preliminary\_5. Stability calculated according to EN 474-12. Max. capacities do not exceed 75 % of tipping load.  
 Above capacities are for reference only and are not programmed in the LML system.  
 Max. main boom 105 ft

# Dragline equipment

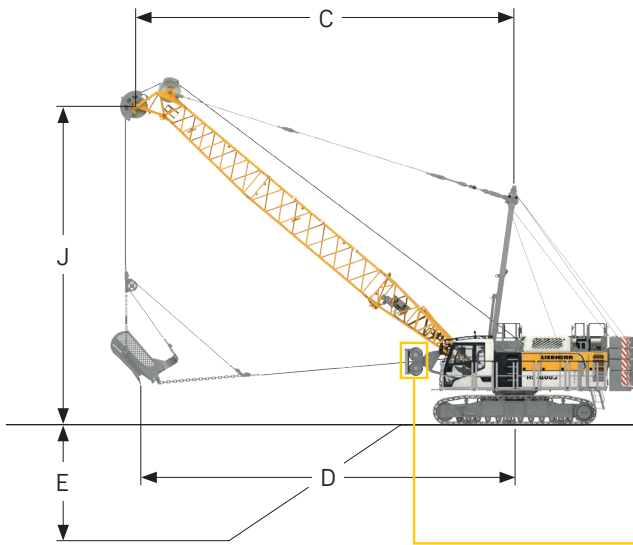

### Digging diagram

- C = Radius / dumping radius
- D = Max. digging radius = approx.  $C + 1/3$  to  $1/2 J$
- E = Digging depth = approx. 40 - 50% of C
- J = Height to centre rope pulley boom head

Rotating fairlead is fitted for dragline operation; diagonal pull limited to a minimum resulting in less rope wear.

### Dragline control (Interlock control system)

The Interlock control system allows for power regeneration in dragline operation. This reduces the fuel consumption as well as the wear of the free-fall winch.

### Lifting height restriction

It prevents the rope end termination from being pulled into the head pulley in an uncontrolled manner. The drag winch is also equipped with this function.

## Capacities in dragline operation

Capacities in [1000 lbs] with 58,000 lbs counterweight

alpha [°]	Boom length [ft]														
	56			66			75			85			95		
	C	J	*	C	J	*	C	J	*	C	J	*	C	J	*
	[ft]	[ft]		[ft]	[ft]		[ft]	[ft]		[ft]	[ft]		[ft]	[ft]	
55	39.0	50.8	44.6	59.0	39.5	17.9	50.3	67.0	33.4	56.0	75.0	28.5	61.6	83.2	24.7
50	42.8	47.8	49.1	55.2	34.5	15.7	55.4	63.0	29.2	61.7	70.4	24.8	68.1	77.9	21.3
45	46.2	44.3	53.2	51.1	31.0	14.1	60.1	58.2	26.0	67.1	65.1	22.0	74.0	72.1	18.9
40	49.4	40.5	56.9	46.8	28.1	12.8	64.4	53.3	23.6	72.0	59.6	19.9	79.5	65.9	16.9
35	52.2	36.6	60.2	42.2	26.0	11.8	68.3	47.8	21.7	76.3	53.5	18.2	84.4	59.1	15.5
30	54.5	32.4	63.1	37.2	24.3	11.0	71.7	42.2	20.1	80.1	47.2	16.9	88.7	52.2	14.3
25	56.6	28.0	65.6	32.1	22.9	10.4	74.5	36.3	19.1	83.4	40.5	15.9	92.3	44.7	13.3

TLT 13649087 0 Preliminary\_5. Stability calculated according to EN 474-12. Max. capacities do not exceed 75 % of tipping load.

Above capacities are for reference only and are not programmed in the LML system. The size of the bucket has to be determined according to local conditions.

Max. main boom 105 ft

\* Capacity in [1000 lbs]

# Planning aid for dragline operation

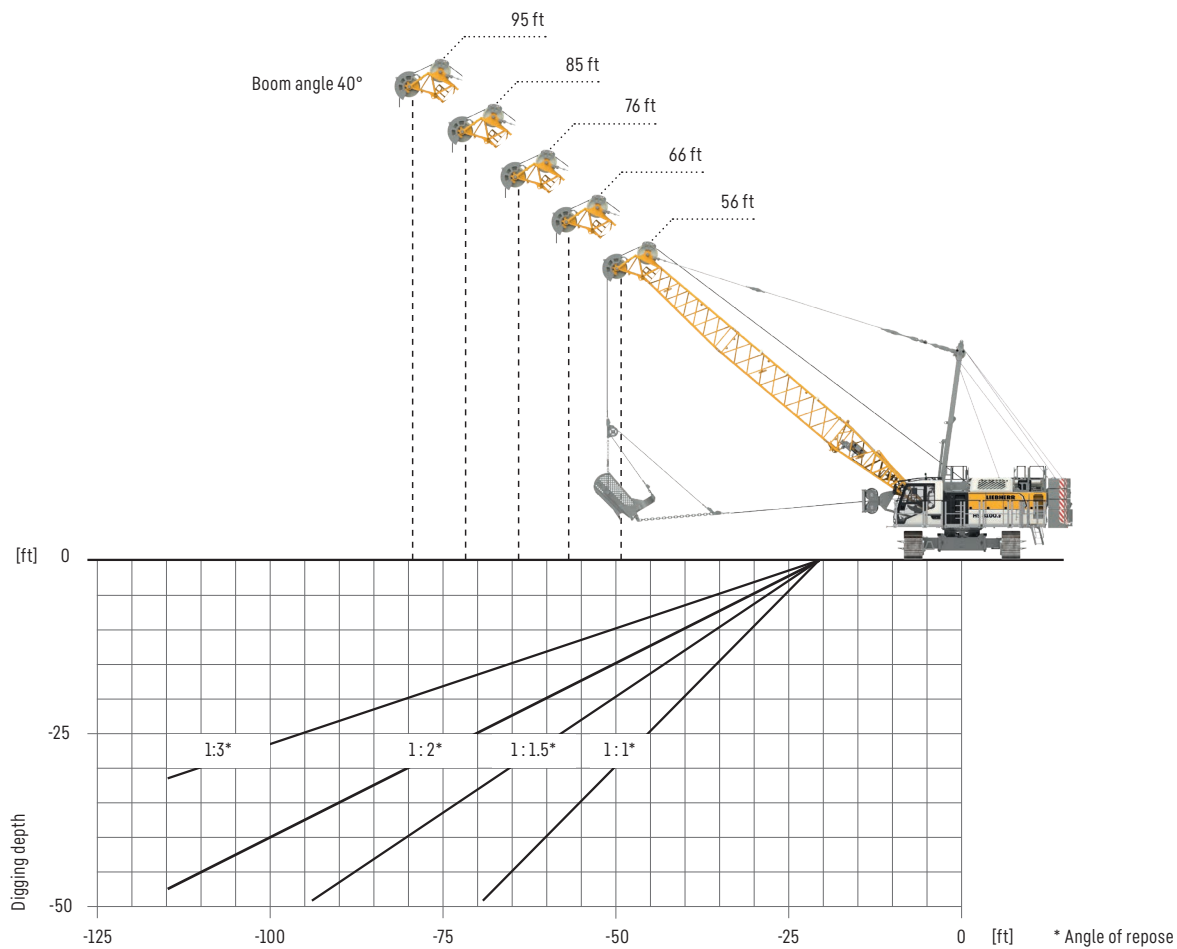

## Selection of dragline bucket and possible digging depths at 40° boom angle

Main boom [ft]	56	66	76	85	95
Dragline bucket [m <sup>3</sup> /yd <sup>3</sup> ]	5.73 / 7.5	4.58 / 6	3.82 / 5	3.06 / 4	2.29 / 3

Density: 1.8 tm<sup>3</sup> and fill factor 0.8

\* The digging depth depends on the material's angle of repose.

# Lifting operation

## Main boom 84°-15°

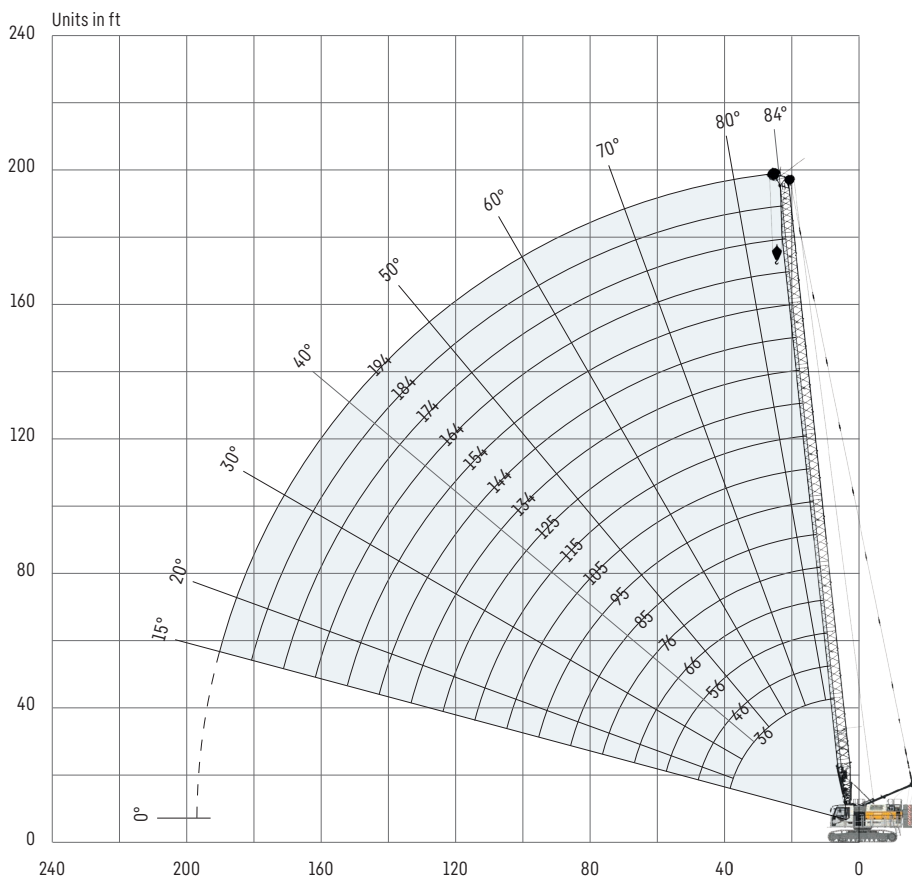

**Auxiliary jib 66,139 lbs**  
 The maximum capacity of the auxiliary jib is 66,139 lbs.  
 The corresponding load chart is programmed in the LML system.

### Main boom configuration

Boom section	Amount of boom sections																
Boom foot 18 ft	1	1	1	1	1	1	1	1	1	1	1	1	1	1	1	1	1
Boom section 10 ft		1		1	1	1	1	1	1	1	1	1	1	1	1	1	
Boom section 20 ft			1	1	2	2	3	3	4	4	5	5	6	6	7	7	8
Boom head 18 ft	1	1	1	1	1	1	1	1	1	1	1	1	1	1	1	1	
<b>Boom length [ft]</b>	<b>36</b>	<b>46</b>	<b>56</b>	<b>66</b>	<b>76</b>	<b>85</b>	<b>95</b>	<b>105</b>	<b>115</b>	<b>125</b>	<b>134</b>	<b>144</b>	<b>154</b>	<b>164</b>	<b>174</b>	<b>184</b>	<b>194</b>
Auxiliary jib	✓	✓	✓	✓	✓	✓	✓	✓	✓	✓	✓	✓	✓	✓	✓	✓	✓

preferred boom combinations











**Capacities in [1000 lbs]**

Radius [ft]	Boom length [ft]														
	36			46			56			66			76		
	58.0	58.0	71.2	58.0	58.0	71.2	58.0	58.0	71.2	58.0	58.0	71.2	58.0	58.0	71.2
*															
9.9		220.5	220.5												
10		220.5	220.5												
13										196.2	218.2	220.5			
14													169.3	187.5	191.5
15	170.3	205.8	205.8	174.8	205.6	207.0	174.9	193.6	207.9	165.1	182.8	195.9	156.2	173.0	190.0
20	127.1	140.6	156.7	127.4	141.0	151.5	122.8	136.1	145.4	117.5	130.3	139.9	112.6	125.0	135.3
25	90.2	99.9	111.5	90.5	100.2	111.8	90.6	100.3	111.9	90.6	100.3	107.5	87.5	97.2	103.9
30	69.3	76.9	86.0	69.6	77.2	86.3	69.7	77.3	86.4	69.6	77.3	86.3	69.5	77.2	84.7
35	55.8	62.0	69.5	56.1	62.4	69.8	56.2	62.5	70.0	56.2	62.4	69.9	56.0	62.3	69.8
40	46.0	46.0	46.0	46.7	52.0	58.3	46.8	52.2	58.5	46.8	52.1	58.4	46.6	52.0	58.3
45				39.9	44.5	49.8	40.1	44.7	50.0	40.0	44.6	49.9	39.9	44.5	49.8
50				34.4	38.4	42.7	34.7	38.8	43.6	34.7	38.8	43.6	34.6	38.6	43.5
55							30.4	34.1	38.4	30.4	34.1	38.4	30.3	34.0	38.3
60										26.9	30.2	34.2	26.9	30.2	34.1
65										24.0	27.0	30.6	24.0	27.0	30.6
70													21.6	24.3	27.6
75													19.4	22.0	25.1

TLT 13649084 0 Preliminary\_1. Load charts are calculated according to EN 13000.

- \* Rear counterweight in [1000 lbs]
- + 33,069 lbs carbody counterweight

Capacities in [1000 lbs]

Radius [ft]	Boom length [ft]														
	85			95			105			115			125		
	58.0	58.0 	71.2 	58.0	58.0 	71.2 	58.0	58.0 	71.2 	58.0	58.0 	71.2 	58.0	58.0 	71.2 
15	148.1	164.1	167.5												
16				131.2	145.5	146.4									
20	108.1	120.0	130.8	103.8	115.2	125.0	99.8	110.9	119.2	96.0	106.7	114.8	92.4	102.7	102.7
25	84.5	93.9	100.4	81.6	90.7	95.9	78.8	87.8	92.2	76.2	84.9	90.3	73.7	82.2	85.8
30	68.8	76.7	80.8	66.7	74.4	78.4	64.7	72.2	75.8	62.7	70.0	72.7	60.8	67.9	69.4
35	55.9	62.1	68.3	55.7	62.0	65.3	54.5	60.9	62.8	52.9	59.2	61.0	51.4	57.6	58.9
40	46.5	51.8	58.1	46.3	51.6	57.2	46.0	51.4	54.6	45.7	51.0	52.3	44.4	49.6	50.4
45	39.7	44.4	49.6	39.5	44.2	49.4	39.3	43.9	48.5	39.1	43.7	46.5	38.7	43.5	44.4
50	34.4	38.5	43.3	34.2	38.3	43.1	34.0	38.0	42.9	33.7	37.8	42.0	33.5	37.5	39.8
55	30.1	33.8	38.1	29.9	33.6	37.9	29.7	33.4	37.7	29.5	33.1	37.4	29.2	32.8	36.0
60	26.7	30.0	33.9	26.5	29.8	33.7	26.2	29.6	33.5	26.0	29.3	33.2	25.7	29.0	32.8
65	23.8	26.8	30.4	23.6	26.6	30.2	23.4	26.4	30.0	23.1	26.2	29.8	22.9	25.9	29.4
70	21.4	24.2	27.5	21.2	24.0	27.3	21.0	23.7	27.0	20.7	23.5	26.8	20.4	23.2	26.5
75	19.3	21.9	25.0	19.1	21.7	24.8	18.9	21.5	24.5	18.7	21.2	24.3	18.4	21.0	24.0
80	17.5	19.9	22.8	17.4	19.8	22.6	17.1	19.5	22.4	16.9	19.3	22.1	16.6	19.0	21.8
85	15.9	18.1	20.8	15.8	18.0	20.7	15.5	17.8	20.5	15.3	17.6	20.2	15.0	17.3	20.0
90				14.4	16.5	19.0	14.2	16.3	18.8	13.9	16.0	18.6	13.7	15.8	18.3
95				13.1	15.1	17.5	12.9	14.9	17.3	12.7	14.7	17.1	12.4	14.4	16.8
100							11.8	13.7	15.9	11.6	13.5	15.7	11.3	13.2	15.5
105							10.8	12.6	14.7	10.6	12.4	14.5	10.4	12.1	14.3
110										9.7	11.4	13.4	9.4	11.2	13.2
115										8.8	10.5	12.4	8.6	10.3	12.2
120													7.8	9.4	11.3
125													7.0	8.6	10.4

TLT 13649084 0 Preliminary\_1. Load charts are calculated according to EN 13000.

\* Rear counterweight in [1000 lbs]  
 + 33,069 lbs carbody counterweight

For boom lengths of 125 ft or more a second angle transmitter must be used in the boom head.



www.liebherr.com/CranePlanner

 **Crane Planner 2.0**

**Capacities in [1000 lbs]**

* Radius [ft]	Boom length [ft]																		
	134			144			154			164			174			184		194	
	58.0	58.0	71.2	58.0	58.0	71.2	58.0	58.0	71.2	58.0	58.0	71.2	58.0	58.0	71.2	58.0	71.2	58.0	71.2
25	71.2	79.5	80.6	69.0	77.0	77.0	66.7	70.4	70.4	59.8	59.8	59.8	51.3	51.3	51.3				
30	58.9	65.9	66.7	57.1	64.0	64.0	55.4	60.8	60.8	53.7	55.0	55.0	48.2	48.2	48.2	41.5	41.5	36.2	36.2
35	49.8	55.9	56.6	48.4	53.9	53.9	46.9	51.5	51.5	45.6	48.4	48.4	43.8	43.8	43.8	37.5	37.5	32.1	32.1
40	43.2	48.3	48.8	41.9	46.9	46.9	40.7	44.9	44.9	39.2	42.1	42.1	38.0	38.8	38.8	33.3	33.3	28.6	28.6
45	37.6	42.5	42.9	36.6	40.9	40.9	35.5	39.2	39.2	34.2	37.3	37.3	33.1	35.4	35.4	30.1	30.1	25.5	25.5
50	33.2	37.3	38.0	32.2	36.0	36.0	31.2	34.5	34.5	30.0	32.8	32.8	29.1	31.1	31.1	27.2	27.2	23.2	23.2
55	28.9	32.6	34.4	28.6	32.1	32.6	27.7	30.9	30.9	26.8	29.1	29.1	25.7	27.6	27.6	24.3	24.3	20.6	20.6
60	25.5	28.8	31.4	25.2	28.5	29.7	24.7	28.0	28.2	23.9	26.4	26.4	22.8	24.8	24.8	21.9	21.9	18.3	18.3
65	22.6	25.6	29.0	22.3	25.3	27.2	22.0	24.8	25.8	21.4	24.1	24.1	20.4	22.6	22.6	20.0	20.0	16.5	16.5
70	20.2	23.0	26.1	19.9	22.7	25.2	19.6	22.4	23.7	19.2	21.9	22.1	18.2	20.7	20.7	18.4	18.4	15.2	15.2
75	18.1	20.7	23.6	17.8	20.4	23.2	17.5	20.1	22.1	17.2	19.6	20.4	16.6	19.0	19.0	17.0	17.0	14.2	14.2
80	16.3	18.7	21.4	16.0	18.4	21.1	15.7	18.1	20.3	15.4	17.8	19.1	14.9	17.4	17.6	15.8	15.8	13.3	13.3
85	14.8	17.0	19.6	14.5	16.7	19.2	14.2	16.4	18.6	13.9	16.1	17.5	13.4	15.7	16.5	14.8	14.8	12.5	12.5
90	13.4	15.5	17.9	13.1	15.2	17.6	12.8	14.9	17.0	12.5	14.6	16.0	12.1	14.2	15.1	13.7	13.9	11.8	11.8
95	12.2	14.2	16.4	11.9	13.9	16.1	11.6	13.6	15.6	11.3	13.3	14.6	10.9	12.8	13.8	12.4	12.7	11.3	11.3
100	11.1	13.0	15.1	10.8	12.7	14.8	10.5	12.4	14.4	10.1	12.1	13.4	9.8	11.7	12.5	11.2	11.5	10.1	10.1
105	10.1	11.9	13.9	9.8	11.6	13.6	9.4	11.3	13.3	9.1	11.0	12.3	8.7	10.6	11.4	10.1	10.4	9.0	9.0
110	9.2	10.9	12.8	8.8	10.6	12.5	8.5	10.3	12.2	8.1	9.9	11.4	7.8	9.6	10.5	9.1	9.5	8.0	8.0
115	8.3	10.0	11.8	7.9	9.7	11.5	7.6	9.3	11.3	7.2	9.0	10.4	6.9	8.6	9.6	8.1	8.6	7.0	7.0
120	7.5	9.2	11.0	7.2	8.8	10.6	6.8	8.5	10.3	6.5	8.1	9.5	6.1	7.8	8.8	7.2	7.8	6.2	6.2
125	6.8	8.3	10.2	6.4	8.0	9.8	6.1	7.7	9.4	5.7	7.3	8.7	5.4	7.0	8.0	6.5	7.1	5.5	5.5
130	6.1	7.6	9.3	5.8	7.3	9.0	5.4	7.0	8.6	5.1	6.6	7.9	4.7	6.2	7.3	5.8	6.4		
135	5.4	6.9	8.4	5.1	6.6	8.2	4.8	6.3	7.9	4.4	5.9	7.2		5.6	6.6	5.1	5.7		
140				4.5	5.9	7.5		5.6	7.2		5.3	6.6		4.9	6.0	4.5	5.0		
145					5.3	6.6		5.0	6.6		4.7	6.0			5.4		4.4		
150								4.5	5.9			5.4			4.9				
155												4.9							

TLT 13649084 0 Preliminary\_1. Load charts are calculated according to EN 13000.

\* Rear counterweight in [1000 lbs]

☐ + 33,069 lbs carbody counterweight

For boom lengths of 125 ft or more a second angle transmitter must be used in the boom head.



www.liebherr.com/CranePlanner

**Crane Planner 2.0**

# Lifting operation with fixed jib

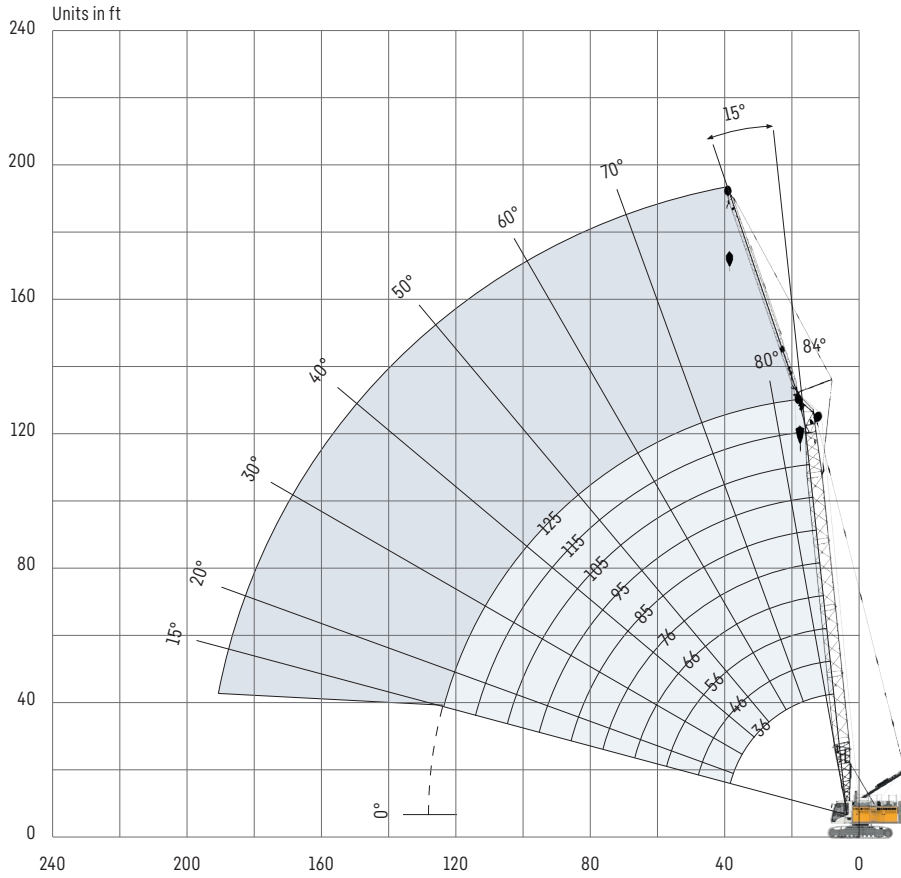

## Jib configuration 0806HS

Jib section	Amount of jib sections	
Jib foot 18 ft	1	1
Jib section 29.5 ft		1
Jib head 18 ft	1	1
<b>Jib length [ft]</b>	<b>36</b>	<b>66</b>

For main boom configuration 66 - 135 ft please refer to the table on page 19.

## Load capacities with fixed jib 15° (0806.20)

Jib length 36 ft with 71,100 lbs rear counterweight  
and 33,100 lbs carbody counterweight, capacities in [1000 lbs]

Radius [ft]	Boom length [ft]				
	66	76	105	125	135
30	40.2	40.4			
35	38.2	38.5	38.8	34.9	33.1
40	36.4	36.6	37.6	33.8	32.0
45	34.9	35.3	36.2	33.1	31.3
50	33.8	34.2	35.2	32.6	30.9
55	33.0	33.4	33.1	32.3	30.6
60	32.3	32.6	31.0	30.0	30.0
65	30.7	30.4	29.4	27.4	27.0
70	27.8	27.6	26.7	25.2	24.6
75	25.2	25.0	24.1	23.4	22.6
80	23.0	22.7	21.9	21.1	20.8
85	21.0	20.8	19.9	19.3	18.8
90	19.3	19.0	18.1	17.6	17.2
95	17.7	17.5	16.6	16.0	15.7
100		16.1	15.2	14.6	14.3
105		14.8	14.0	13.4	13.1
110			12.8	12.2	11.9
115			11.8	11.2	10.9
120			10.8	10.2	9.9
125			10.0	9.3	9.0
130			9.1	8.5	8.1
135				7.7	7.3
140				6.9	6.6
145				6.2	5.9
150				5.6	5.3
155					4.6

TLT 13649084 0 Preliminary\_1. Load charts are calculated according to EN 13000.  
Above load charts are for reference only.  
For actual lift duty please refer to load chart in operator's cabin or manual.

Jib length 66 ft with 71,200 lbs rear counterweight  
and 33,100 lbs carbody counterweight, capacities in [1000 lbs]

Radius [ft]	Boom length [ft]				
	66	76	105	125	135
40	18.9	18.9			
45	17.9	17.9	17.5	16.9	
50	17.2	17.2	16.9	16.4	16.2
55	16.7	16.8	16.5	16.1	15.9
60	16.1	16.3	16.2	15.8	15.7
65	15.6	15.8	15.9	15.6	15.4
70	15.2	15.4	15.8	15.4	15.2
75	14.7	15.0	15.6	15.3	15.1
80	14.3	14.6	15.5	15.3	14.8
85	13.9	14.2	15.4	15.2	14.6
90	13.6	13.9	14.9	15.2	14.4
95	13.2	13.6	14.4	14.9	14.3
100	12.9	13.2	14.0	14.4	13.8
105	12.6	12.9	13.7	14.0	13.2
110	12.4	12.7	13.4	13.0	12.7
115	12.2	12.5	12.6	12.0	11.7
120	12.0	12.3	11.6	11.2	10.9
125	11.9	11.7	10.9	10.3	10.0
130		11.0	10.1	9.5	9.1
135		10.2	9.3	8.7	8.3
140			8.6	7.9	7.6
145			7.9	7.2	6.9
150			7.3	6.6	6.2
155			6.6	6.0	5.6
160			6.0	5.4	5.0
165				4.8	4.5

TLT 13649084 0 Preliminary\_1. Load charts are calculated according to EN 13000.  
Above load charts are for reference only.  
For actual lift duty please refer to load chart in operator's cabin or manual.



# Transport dimensions and weights

## Basic machine and main boom (1311.24)

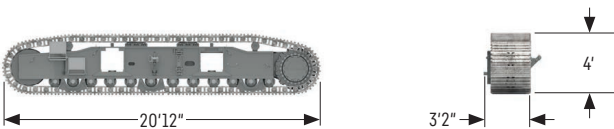
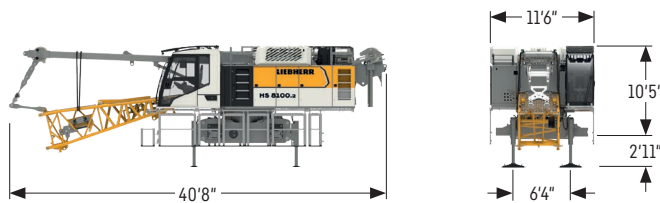
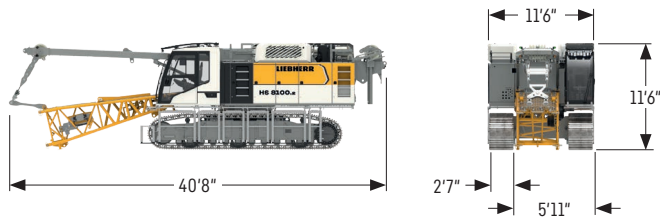

### Basic machine

with HD undercarriage, boom foot (1311.24), A-frame, 2x 66,319 lbf winches including wire ropes (295 ft), without rear counterweight

Width	inch	137.8
Weight with 2.6 ft 3-web grousers	lbs	130,734
Weight with 3 ft 3-web grousers	lbs	132,233
Weight of hoist ropes (2x 295 ft)	lbs/ft	3.82

### Basic machine (option)

with boom foot (1311.24), A-frame, 2x 66,319 lbf winches including wire ropes (295 ft), without rear counterweight and crawlers

Width	inch	137.8
Weight	lbs	88,692
Weight of hoist ropes (2x 90 m)	lbs/ft	3.82

### Crawler (2x)

3-web grousers	inch	31.5
Width	inch	36
Weight with 2.6 ft 3-web grousers	lbs	21,275
Weight with 3 ft 3-web grousers (option)	lbs	21,693
Weight with 3 ft flat track pads (option)	lbs	22,267
Weight with 3.3 ft 3-web grousers (option)	lbs	22,818

### Boom section 10 ft (1311.24)

Width	inch	56.3
Weight incl. pendant ropes	lbs	1,157

### Boom section 20 ft (1311.24)

Width	inch	56.3
Weight incl. pendant ropes	lbs	1,940

### Boom head\* (No. 1311.24)

Width	inch	56.3
Weight incl. pendant ropes	lbs	4,674

\*) Steel sheaves (2+3)

### Auxiliary jib

Width	inch	44.7
Weight	lbs	2,392

Weights can vary with the final configuration of the machine. The figures in this brochure may include options which are not within the standard scope of supply of the machine.

## Fixed jib

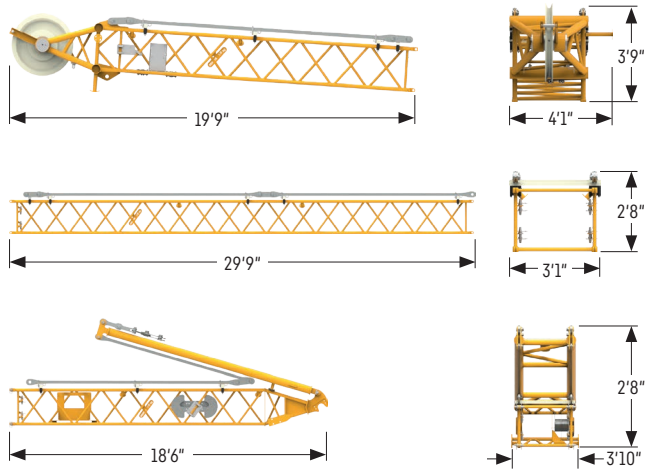

### Jib head

Width	inch	49.2
Weight	lbs	1,455

### Jib section 30 ft

Width	inch	36.6
Weight	lbs	1,272

### Jib foot with A-frame

Width	inch	46.5
Weight	lbs	2,352

## Counterweight

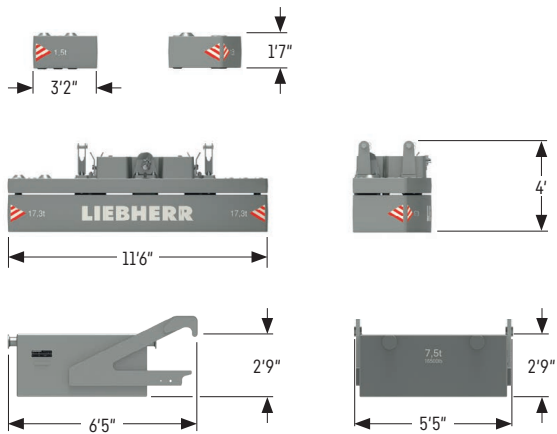

### Counterweight slab (standard 6x, option 10x)

Width	inch	33.5
Weight	lbs	3,307

### Counterweight slab (1x)

Width	inch	41.3
Weight	lbs	38,206

### Carbody counterweight (option 2x)

Width	inch	64.6
Weight	lbs	16,535

# Hooks

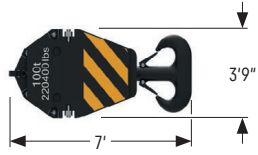

## 220,462 lbs hook block - 2 sheaves

Width	inch	10.6
Weight	lbs	2,646

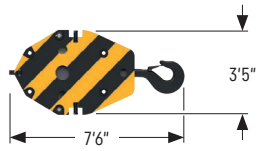

## 198,416 lbs hook block - 1 sheave

Width	inch	13.7
Weight	lbs	2,756

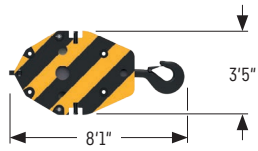

## 165,347 lbs hook block - 1 sheave

Width	inch	7.6
Weight	lbs	2,756

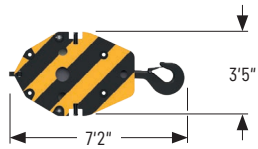

## 132,277 lbs hook block - 1 sheave

Width	inch	6.4
Weight	lbs	2,138

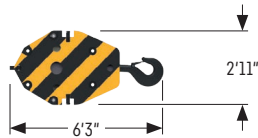

## 110,231 lbs hook block - 1 sheave

Width	inch	9.1
Weight	lbs	1,653

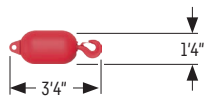

## 66,139 lbs single hook

Width	inch	15.7
Weight	lbs	1,944

# Self-assembly system



Unloading of basic machine (option)

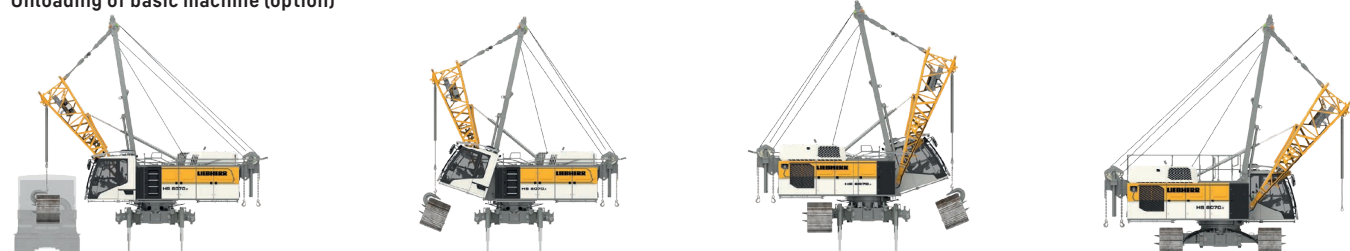

Unloading and assembly of crawlers



Unloading of basic machine (standard)

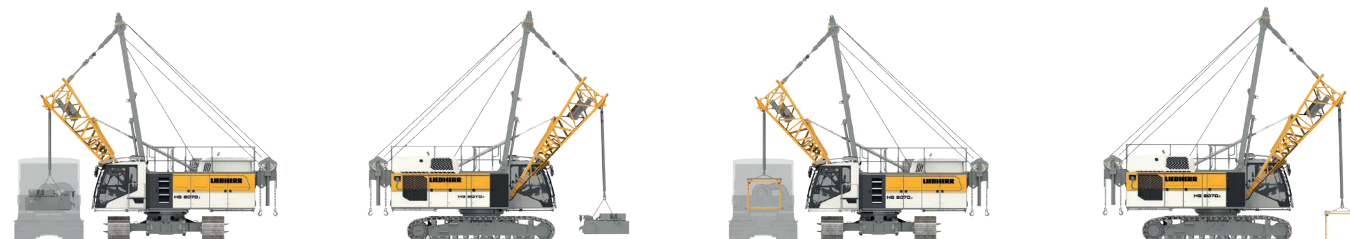

Unloading and assembly of carbody counterweight

Unloading and assembly of boom

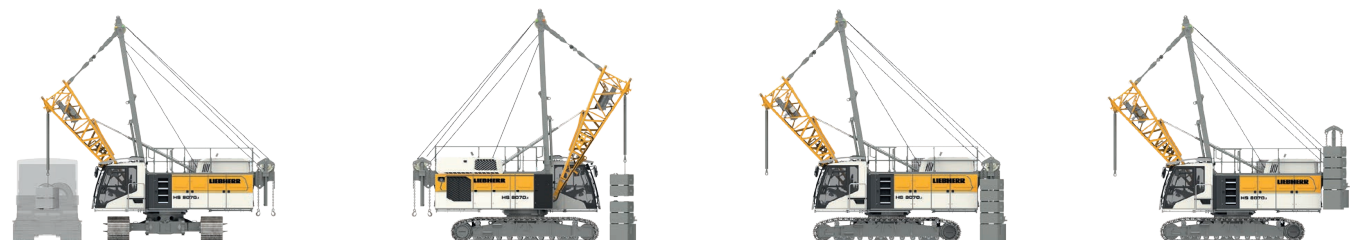

Unloading and assembly of rear counterweight



Assembly of boom and reeving of hoist ropes



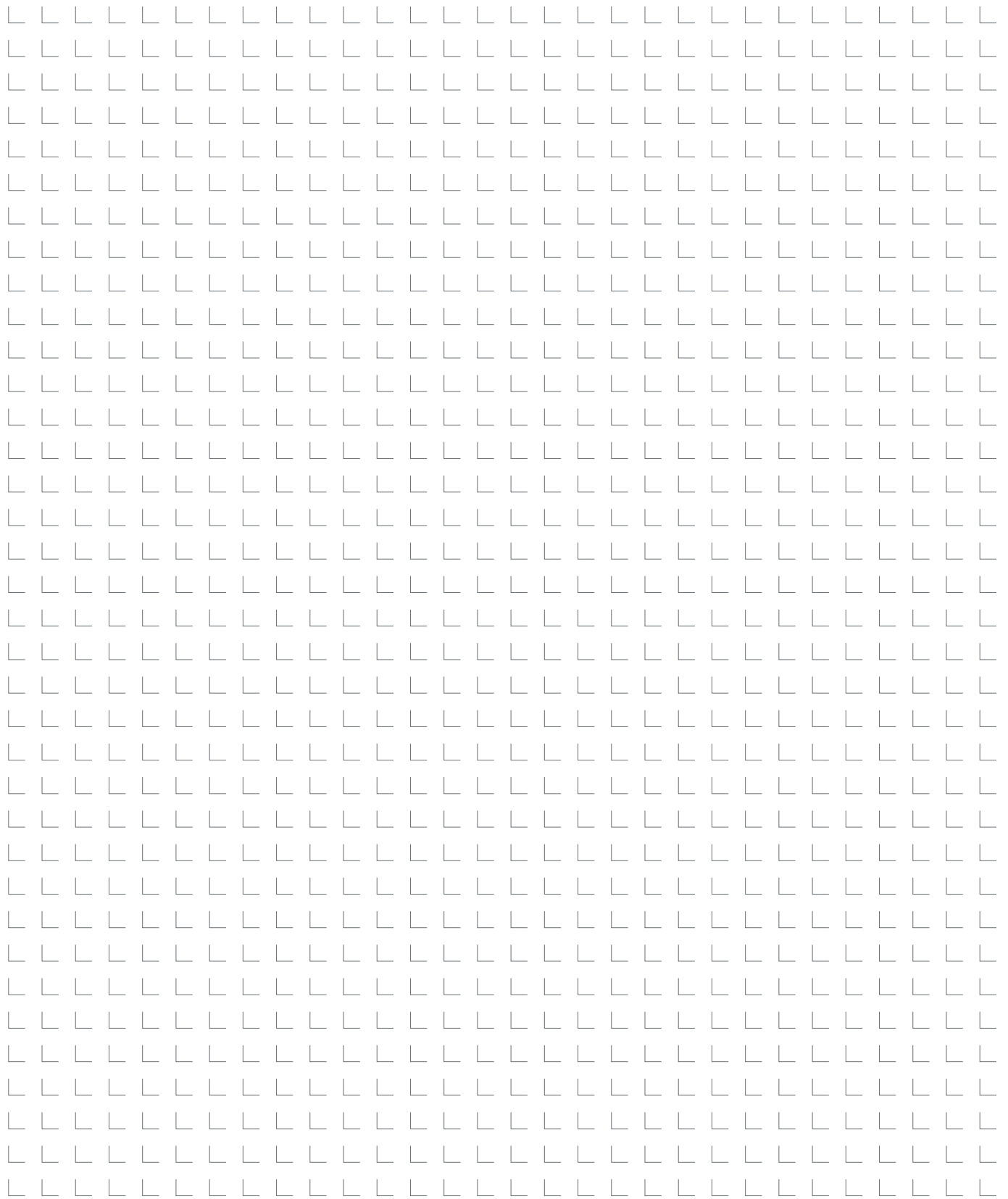

Liebherr-Werk Nenzing GmbH · Dr. Hans Liebherr Str. 1 · 6710 Nenzing, Austria  
Phone +43 50809 41-473 · [crawler.crane@liebherr.com](mailto:crawler.crane@liebherr.com) · [www.liebherr.com](http://www.liebherr.com)  
[facebook.com/LiebherrConstruction](https://facebook.com/LiebherrConstruction)

Liebherr USA, Co. · 7075 Bennington Street · Houston, TX 77028-5812  
Phone (713) 636-4050 · [crawler.cranes.usa@liebherr.com](mailto:crawler.cranes.usa@liebherr.com) · [www.liebherr.com](http://www.liebherr.com)  
[facebook.com/LiebherrConstruction](https://facebook.com/LiebherrConstruction)