

---

# L 507 E

---

Product information

**LIEBHERR**

Battery-electric wheel loader

**Generation**

8

**Battery**

32.2 / 64.4 kWh

**Tipping load**

3,750 kg



# An high-energy concept for success

---



**Tipping load, articulated**  
3,750 kg

**Bucket capacity**  
0.9 m<sup>3</sup>

**Operating weight**  
5,910 kg

**Battery**  
32.2 / 64.4 kWh

## Performance

- Dynamic and powerful performance due to innovative electric drive system
- Exceptional manoeuvrability and versatility thanks to the proven Stereo steering system
- The Stereo steering's combination of articulated steering and steered rear axle means a reduced articulation angle of only 30°
- A lower articulation angle results in maximum all-terrain stability
- High breakout forces in the lower lift arm range combined with strong holding forces in the upper lift arm range mean greater productivity in all applications
- Intelligent machine design makes it possible to transport heavy payloads with a low operating mass
- At a top speed of 30 km/h, the Speeder version increases the handling capacity of this wheel loader, especially over long distances

## Economy

- Long battery runtimes of up to 8 hours (or optionally up to 16 hours) increases productivity in wheel loader operation
- Maximum efficiency due to energy recuperation
- No localised CO<sub>2</sub> emissions thanks to the battery-electric drive
- Excellent traction even on difficult terrain
- With the optional hydraulic quick coupler "Solidlink" with integrated, automatic hydraulic coupling system, changing the hydraulic attachments is done in just seconds, all right from the cab – changeover is fully automatic, safe and without oil leakage
- Maximum efficiency thanks to optimum coordination between the electric motor and the other components

## Maintainability

- The reduced maintenance requirements of electric machines results in maximum availability
- Effective and prompt support thanks to an expansive service network with qualified service specialists
- Spare parts service with round-the-clock delivery

## Reliability

- Liebherr's decades of experience in the development, design and production of components makes these machines exceptionally durable
- Optimal coordination between individual components for significant robustness and reliability
- Liebherr's high quality standards mean dependability – even under the toughest operating conditions
- Demand-controlled cooling for improved cooling performance and reliable service
- With the clever positioning of the radiator package there is less contamination, so downtime is minimised

## Comfort

- Thanks to very low noise emissions, the L 507 E is exceptionally well suited to noise-sensitive areas, providing the operator with a pleasant and peaceful work environment
- The modern ergonomic cab design allows the operator to remain better focussed, reducing fatigue
- Displays, control elements, and the operator's seat are perfectly harmonised forming a single ergonomic unit
- Numerous storage compartments and clever features provide plenty of space in the cab and a comfortable interior
- With the Liebherr control lever, which moves along with the operator's seat, all working and driving functions can be controlled safely and precisely
- The optional Liebherr control lever with mini-joystick makes work more relaxed and efficient and provides proportional control of hydraulic attachments
- The high proportion of glass in the cab provides excellent all-round visibility of working attachments and the operating area
- The engine bonnet was designed with optimised visibility in mind – this, together with the optional reversing camera, ensures an excellent overview
- Thanks to the side window that can open 180°, there is much better air circulation in the cab and it is easier to communicate with those outside of the cab
- The damped articulated pendulum joint compensates for uneven ground and ensures excellent stability and maximum comfort

# The L 507 E at a glance

---

## Stereo steering

---

Balanced and one-of-a-kind – Liebherr's Stereo steering technology has been borne out by decades of excellence and is as unique as ever: It is a perfectly harmonised combination of articulated steering and rear axle steering. The Stereo concept combines the advantages of conventional articulated steering with the benefits of all-wheel steering. The result is a minimal turning circle which is particularly practical in cramped conditions. Even difficult steering manoeuvres are a breeze for the L 507 E.

## Lift arms

---

Strong and robust – the powerful Z-bar kinematics have impressive hydraulic components, robust and durable lift arms and a strong steel construction. Safe lifting and loading without the need for manual readjustment and no loss of load, as well as quick and impressive positioning of loading material. The intelligent machine design of the L 507 E ensures risk-free transportation of loads even on rough terrain. The optional combination of electrohydraulics and angle sensors provides additional possibilities for machine coordination.



## Stability and resistance to tipping over

---

Durable and manoeuvrable – the unique, articulated pendulum joint compensates for uneven ground and results in a comfortable and stable ride. With a tight turning radius and an articulation angle of only 30°, the one-of-a-kind Stereo steering provides additional stability and incredible manoeuvrability. The optimal ratio between operating mass and tipping load ensures maximum productivity.



## Cab

With excellent visibility and comfort, the ergonomically optimised cab design provides a pleasant and fatigue-free work environment. The spacious interior with an operator's seat, which can be adjusted in almost any way, offer the operator the highest level of comfort. Expansive windows and an engine bonnet designed for optimised visibility give the operator an unobstructed view in all directions. The optional, integrated reversing camera further increases visibility behind the machine. The electric-drive and the Stereoloader's simple handling, complete with steering wheel, make it easy to learn so that the operator can quickly get to grips with the machine. That saves time and increases versatility.

## Battery-electric drive

Innovative and effective – the L 507 E's electric drive creates no local emissions and little noise, making this wheel loader ideal for use in urban areas as well as indoors. Through the use of energy recuperation, energy loss is kept to a minimum and efficiency is increased without compromising the power output. The full extent of the electric drive's power output is accessible at all times, ensuring that work is accomplished quickly. To guarantee operational safety, all maintenance points are easily and safely accessible from the ground.

# The battery-electric wheel loader powered by innovation



## Full loading power

The lithium-ion technology integrated into the L 507 E with its mean voltage of 322 V provides optimal performance. Depending on the on-board charger and power rating, the battery can be completely recharged in one and a half to three hours. The on-board charging system guarantees fast charging without additional external equipment, while making easy intermediate charging possible and increasing the machine's versatility. With just one flap to open in the cab access area of the wheel loader, the charging process is as simple as can be.



## Individual power output thanks to the modular battery concept

Whether at 32.2 kWh or the optional 64.4 kWh, this battery-electric wheel loader from Liebherr is ready for any job. The modular battery concept makes it possible to individually adapt the machine's power.

## Simply safe

Permanent, system-controlled monitoring of the high-voltage plug contacts and electric wiring means that circuitry is automatically switched off in the event of a defect. This mechanism significantly increases safety while the machine is in operation.





### The quiet drive speaks for itself

The significantly reduced noise emissions of this battery-electric wheel loader by Liebherr provide huge advantages, especially in noise-sensitive areas like city centres. The fact that its drive is electric and emissions-free makes the L 507 E ideal for use in enclosed spaces such as recycling facility buildings.



### Control units that are easy to use

The height adjustable touch function display allows work-related data to be collected quickly. Control elements that are easy and intuitive to use and an improved layout provide an ideal working environment inside the cab. The progress of the charging process is shown as a percentage on the wheel loader's display along with a charge time prediction as well as multiple settings options. Using this data, there is nothing standing in the way of well-planned and efficient operation.

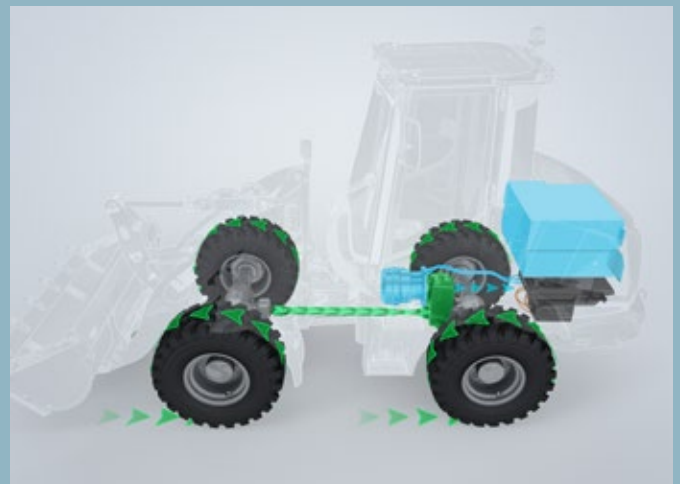

### Intelligent energy recuperation

Regenerated energy – recuperated during braking or driving downhill – back to the battery increases its mileage. This process makes this battery-operated wheel loader from Liebherr particularly economical and resource-efficient. Lively handling and quick work sequences are easy to achieve with an electric drive that can provide full power output in a second.

# Technical data



## Battery

		L 507 E	
<b>High-voltage system</b>			
Battery type		Lithium ion	
Battery voltage	V	322	
Battery capacity	kWh	32.2	64.4*
Reference value for running time**	h	up to 8	up to 16
Emission stage		emission-free	
<b>Charging infrastructure / charging times for internal charger, 10-90%</b>			
Charging socket		Typ 2 / CCS2***	
230V / 12 A (3.5 kW)	h	7.1	14.2
400V / 16 A (11 kW)	h	2.1	4.2
400V / 32 A (22 kW)	h	1.1	2.1
DC rapid charging (up to 45 kW)***	h	-	1.1
<b>Low-voltage system</b>			
Operating voltage	V	12	
Capacity	Ah	100	

\* optional, operating mass + 220 kg

\*\* depending on use, machine configuration and ambient conditions

\*\*\* optional



## Brakes

		L 507 E
<b>Wear-free service brake</b>		Electric travel drive with regenerative brakes, wear-free, applied to all four wheels and additional dual-circuit brake system, drum brake and wet multi-disc brake located in the front axle
<b>Parking brake</b>		Negative brake system in the front axle acting on the wet multi-disc brakes

The braking system meets the requirements of the ISO 3450.



## Axles

		L 507 E
<b>Four-wheel drive</b>		
<b>Front axle</b>		Fixed
<b>Rear axle</b>		Axle pivot steering, fixed
Height of obstacles which can be driven over	mm	370
with all four wheels remaining in contact with the ground		
<b>Differentials</b>		
Open differentials in both axles; 100% differential lock in front axle, manually engaged		
<b>Reduction gear</b>		Planetary final drive in wheel hubs
<b>Track width</b>		1.510 mm with tyres indicated as standard



## Driveline

		L 507 E
<b>Electric travel drive</b>		
Design		Permanent magnet synchronous motor
Description of travel drive		Continuously variable electric direct drive with energy recuperation
Travel drive motor power output	kW	30
Control		By travel and inching pedal. The inching pedal makes it possible to control the tractive and thrust forces steplessly. The Liebherr control lever is used to control forward and reverse travel
<b>Travel speed range</b>		
Standard		Speed range: 0-20 km/h
Speeder		Speed range: 0-30 km/h*
Speeds quoted apply with the tyres indicated as standard on loader model.		

\* Configuration, tyres and mounting tools can influence the maximum speed.

## Steering

<b>Design</b>	Stereo steering system, hydraulic servo power steering. Central oscillating frame articulation with damper element in combination with rear-axle pivot steering	
<b>Angle of articulation</b>	30° to each side	
<b>Angle of oscillation - centre-pivot steering</b>	8° to each side	
<b>Max. pressure</b>	bar	180

## Attachment hydraulics

<b>Electric motor design</b>	<b>L 507 E</b>	
<b>Electric motor power output (max)</b>	Permanent magnet synchronous motor	
<b>Electric motor power output (continuous)</b>	kW	30
<b>Hydraulic system design</b>	Load-sensing axial piston variable displacement pump with power regulator and flow regulator, pressure cut-off in control valve block	
<b>Cooling</b>	Hydraulic oil cooling using thermostatically controlled fan	
<b>Filtration Control</b>	Return flow in-line filter Single-lever control with electro-proportional pilot control, 1st and 2nd additional function with electro-proportional control optional	
<b>Lifting function</b>	Lifting, neutral, lowering Float position via latching Liebherr control lever, auto lifting and lowering via Liebherr control lever optional	
<b>Tilt function</b>	Tilt back, neutral, dump Automatic bucket return to dig for tipping on and off via Liebherr control lever optional	
<b>Max. flow</b>	l/min.	75
<b>Max. pressure</b>	bar	240
<b>Hydraulic working motor power output</b>	kW	15

## Attachment

<b>Geometry</b>	<b>L 507 E</b> Powerful Z-bar linkage with tilt cylinder, hydraulic quick hitch as standard	
<b>Bearings</b>	Lathe-turned thick-walled bushings with lubricating grooves	
<b>Cycle time at nominal load</b>	ZK	
Lifting	s	4.9
Dumping	s	1.7
Lowering (empty)	s	3.5

## Cab

<b>Design</b>	Elastic mounted, noise-proof cab ROPS roll over protection per EN ISO 3471 / EN 474-1 FOPS falling objects protection per EN ISO 3449 / EN 474-1, Cat. II Operator's door with 180° opening angle with rigid window, fold-out window on right with 12° gap opener or 180° opening, single-pane safety glass ESG, heated rear window ESG, all windows are tinted. Continuously adjustable steering column optional	
<b>Liebherr operator's seat</b>	5 way adjustable, vibration-damped operator's seat "Standard" (mechanically sprung, adjustable to operator's weight), Liebherr control lever mounted into the operator's seat as standard	
<b>Cab heating and ventilation</b>	Fresh air mode, electrical heating, arrangement of the air nozzles ensures quick defrosting and defogging of the windows, electrically heated rear window	

<b>Vibration emissions</b>		
Vibrations in the hand/arm	m/s <sup>2</sup>	≤ 2.5
Vibrations through the whole body	m/s <sup>2</sup>	≤ 0.5

## Sound level

<b>Sound pressure level to ISO 6396</b>	<b>L 507 E</b>	
L <sub>PA</sub> (inside cab)	dB(A)	65
<b>Sound power level to 2000/14/EC</b>		
L <sub>WA</sub> (surround noise)	dB(A)	91

## Capacities

<b>Transmission</b>	l	<b>L 507 E</b> 2.1
<b>HV component coolant</b>	l	9.2
<b>E-drive coolant</b>	l	7.5
<b>Front axle / differential</b>	l	5.0
<b>Rear axle / differential</b>	l	4.4
<b>Front axle / wheel hubs</b>	l	1.6
<b>Rear axle / wheel hubs</b>	l	1.6
<b>Hydraulic tank</b>	l	51
<b>Hydraulic system, total</b>	l	70

# Dimensions

## Z-bar linkage

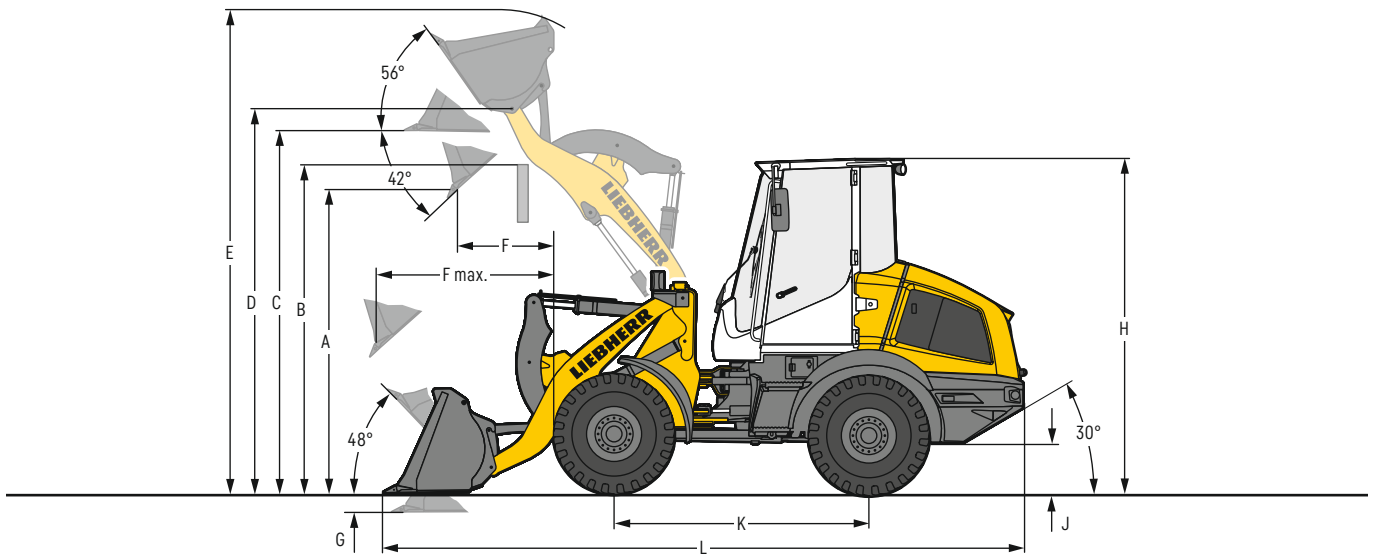

### Liebherr bucket with straight base

	L 507 E		
		STD	HL
Geometry		ZK-QH	ZK-QH
Cutting tools		T	T
Lift arm length	mm	2,150	2,250
Bucket capacity according to ISO 7546 **	m <sup>3</sup>	0.9	0.8
Specific material density	t/m <sup>3</sup>	1.8	1.8
Bucket width	mm	2,050	1,900
A Dumping height at max. lift height and 42° discharge	mm	2,550	2,780
B Dump-over height	mm	2,870	3,060
C Max. height of bucket bottom	mm	3,015	3,200
D Max. height of bucket pivot point	mm	3,215	3,400
E Max. operating height	mm	4,040	4,230
F Reach at max. lift height and 42° discharge	mm	815	780
F max. Max. reach at 42° discharge	mm	1,500	1,605
G Digging depth	mm	80	70
H Height above cab	mm	2,780	2,780
J Ground clearance	mm	285	285
K Wheelbase	mm	2,150	2,150
L Overall length	mm	5,495	5,640
Turning circle radius over tyres	mm	3,520	3,520
Turning circle radius over outside bucket edge	mm	3,885	3,890
Breakout force (SAE)	kN	48	52
Tipping load, straight *	kg	4,070	4,000
Tipping load, fully articulated *	kg	3,750	3,610
Operating weight*	kg	5,910	5,990
Tyre size		405/70R18	405/70R18 L2

\* The figures shown include the above tyres, all lubricants, batterie standard (32.2kWh), the ROPS/FOPS cab and the operator.

Different tyres and optional equipment will change the operating weight and tipping load. (Tipping load, fully articulated according to ISO 14397-1)

\*\* Actual bucket capacity may be approx. 10% larger than the calculation according to ISO 7546 standard. The degree to which the bucket can be filled depends on the material – see page 22.

STD = Standard lift arm length

HL = High Lift

ZK-QH = Z-bar linkage incl. quick hitch

T = Welded-on tooth holder with add-on teeth

# Dimensions

## Z-bar linkage

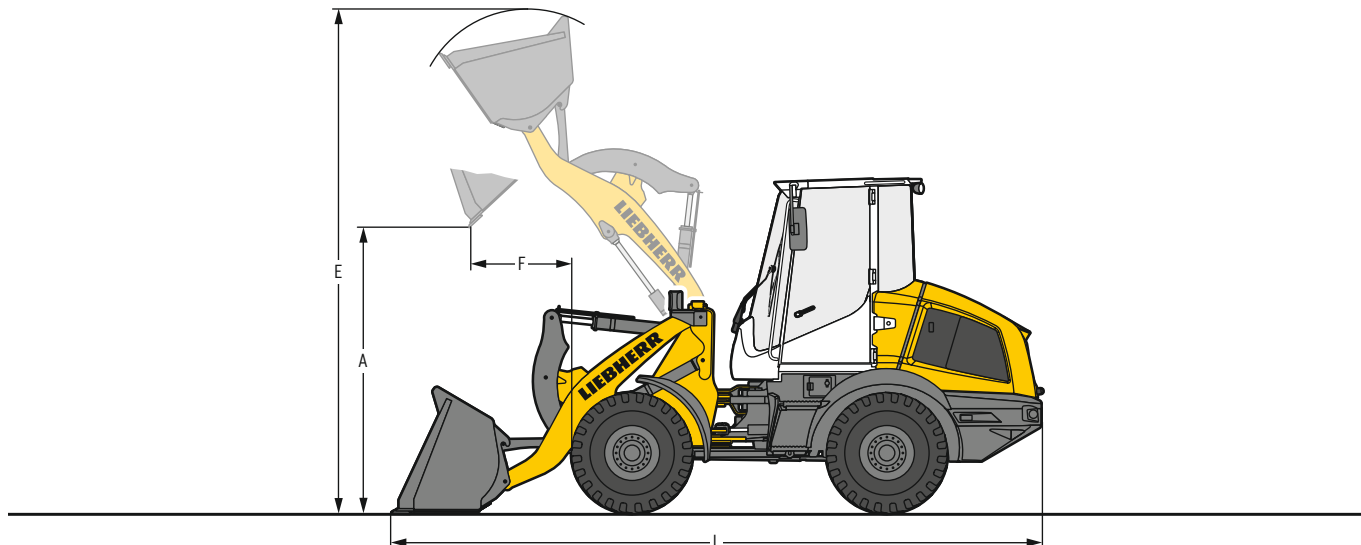

### Light material bucket – heavy material density

		L 507 E		
		STD	STD	HL
		ZK-QH	ZK-QH	ZK-QH
Geometry		BOCE	BOCE	BOCE
Cutting tools		1.2	1.6	1.2
Bucket capacity	m <sup>3</sup>	1.4	1.0	1.2
Specific material density	t/m <sup>3</sup>	2,330	2,400	2,330
Bucket width	mm	2,510	2,420	2,705
A Dumping height at max. lift height	mm	4,130	4,205	4,315
E Max. operating height	mm	840	870	845
F Reach at maximum lift height	mm	5,465	5,580	5,610
L Overall length	mm	3,920	3,825	3,820
Tipping load, straight*	kg	3,575	3,490	3,440
Tipping load, fully articulated*	kg	6,035	6,090	6,120
Operating weight*	kg	405/70R18		
Tyre size				

\* The figures shown include the above tyres, all lubricants, batterie standard (32.2kWh), the ROPS/FOPS cab and the operator.  
Different tyres and optional equipment will change the operating weight and tipping load. (Tipping load, fully articulated according to ISO 14397-1)

STD = Standard lift arm length  
HL = High Lift  
ZK-QH = Z-bar linkage incl. quick hitch  
BOCE = Bolt-on cutting edge

# Dimensions

## Z-bar linkage

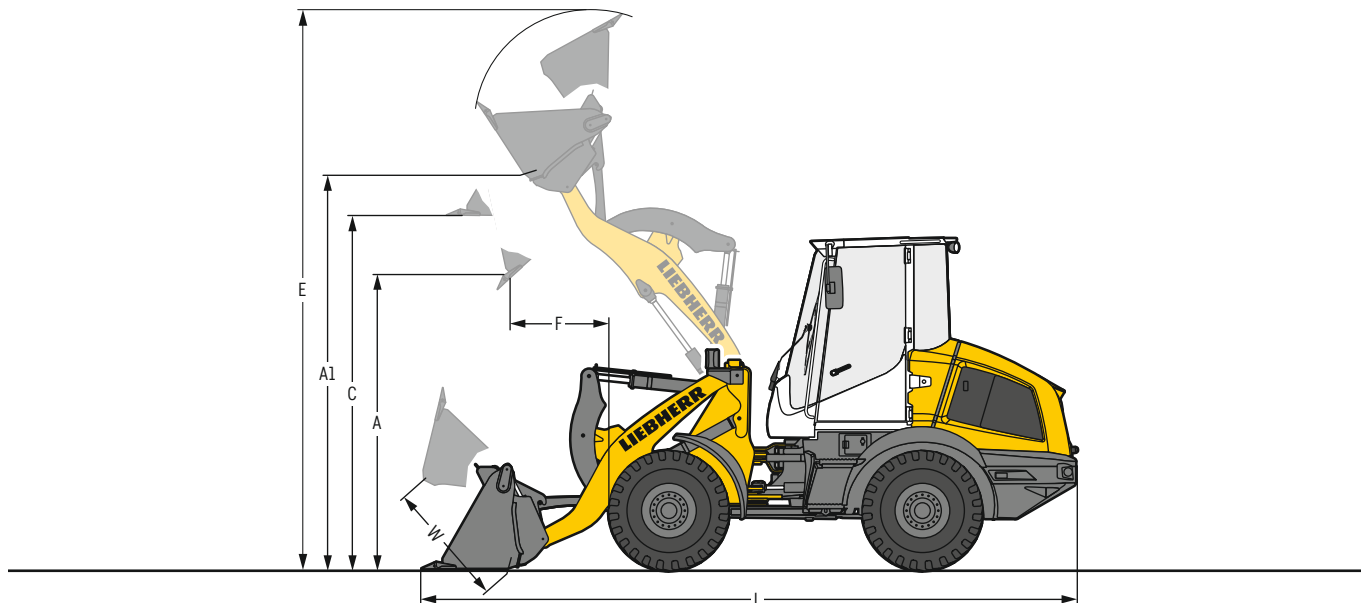

### 4 in 1 bucket

	L 507 E		
	STD		HL
Geometry	ZK-QH		ZK-QH
Cutting tools	T		T
Bucket capacity	m <sup>3</sup>	0.8	0.7
Specific material density	t/m <sup>3</sup>	1.8	1.8
Bucket width	mm	2,100	1,950
A Dumping height at max. lift height and 42° discharge	mm	2,545	2,705
A1 Max. dumping height with opened bucket	mm	3,230	3,500
C Max. height of bucket bottom	mm	2,950	3,200
E Max. operating height	mm	4,720	4,905
F Reach at max. lift height and 42° discharge	mm	880	850
L Overall length	mm	5,585	5,615
W Max. bucket opening	mm	960	960
Turning circle radius over outside bucket edge	mm	3,975	3,925
Tipping load, straight*	kg	3,550	3,520
Tipping load, fully articulated*	kg	3,240	3,210
Operating weight*	kg	6,195	6,280
Tyre size	405/70R18		

\* The figures shown include the above tyres, all lubricants, batterie standard (32.2 kWh), the ROPS/FOPS cab and the operator.  
Different tyres and optional equipment will change the operating weight and tipping load. (Tipping load, fully articulated according to ISO 14397-1)

STD = Standard lift arm length  
HL = High Lift  
ZK-QH = Z-bar linkage incl. quick hitch  
T = Welded-on tooth holder with add-on teeth

# Dimensions

## Z-bar linkage

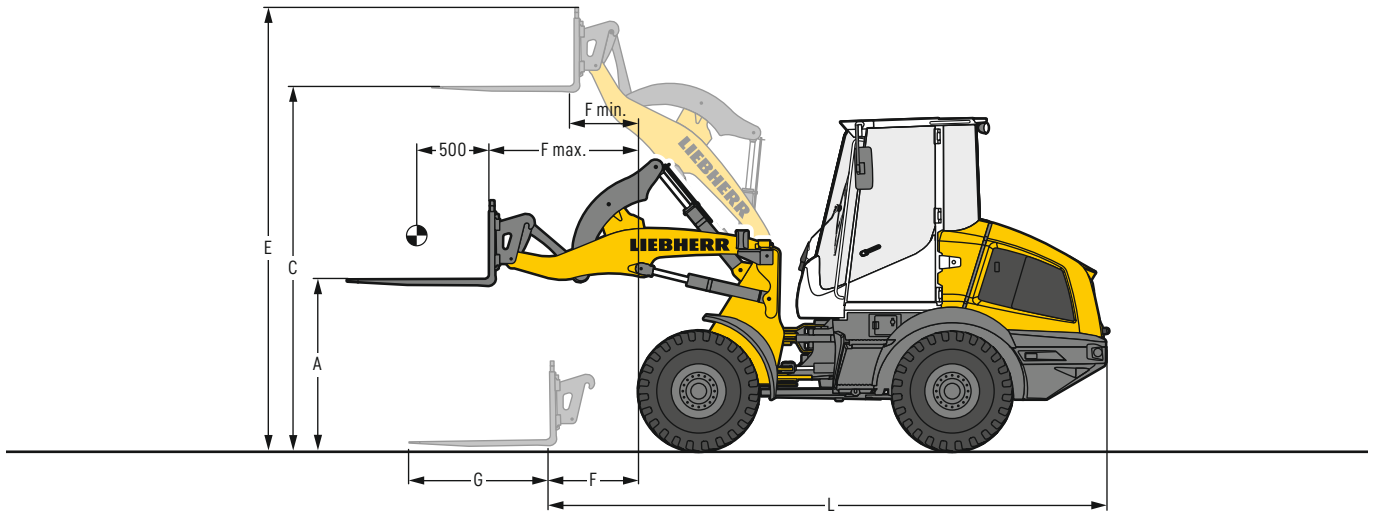

### FEM II fork carrier and fork

		L 507 E	
		STD ZK-QH	HL ZK-QH
<b>Geometry</b>			
<b>A</b> Lifting height at max. reach	mm	1,450	1,450
<b>C</b> Max. lifting height	mm	3,045	3,225
<b>E</b> Max. operating height	mm	3,715	3,900
<b>F</b> Reach at loading position	mm	740	855
<b>F max.</b> Max. reach	mm	1,235	1,340
<b>F min.</b> Reach at max. lifting height	mm	525	460
<b>G</b> Fork length	mm	1,200	1,200
<b>L</b> Length – basic machine	mm	4,825	4,945
<b>Tipping load, straight*</b>	kg	3,215	3,080
<b>Tipping load, fully articulated*</b>	kg	2,930	3,790
<b>Recommended payload for uneven ground = 60% of tipping load, articulated<sup>2)</sup></b>	kg	1,820	1,670
<b>Recommended payload for smooth surfaces = 80% of tipping load, articulated<sup>2)</sup></b>	kg	2,300 <sup>1)</sup>	2,240
<b>Operating weight*</b>	kg	5,815	5,900
<b>Tyre size</b>		405/70R18	

\* The figures shown include the above tyres, all lubricants, batterie standard (32.2kWh), the ROPS / FOPS cab and the operator.  
Different tyres and optional equipment will change the operating weight and tipping load. (Tipping load, fully articulated according to ISO 14397-1)

<sup>1)</sup> Payload is limited by tilt cylinder – max. load capacity for the fork carrier FEM II 2,500 kg

<sup>2)</sup> According to EN 474-3

STD = Standard lift arm length

HL = High Lift

ZK-QH = Z-bar linkage incl. quick hitch

# Bucket selection

## L 507 E

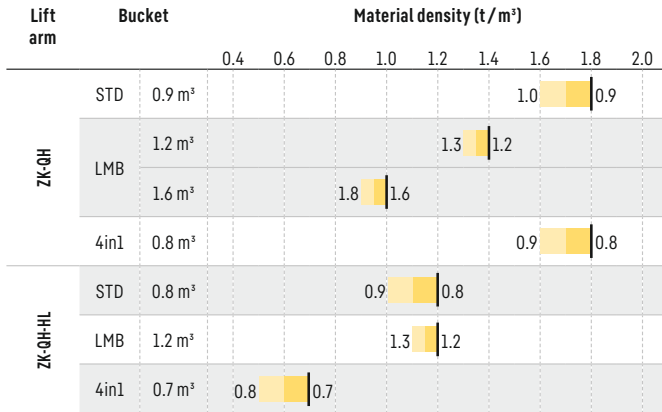

## Bucket filling factor

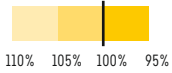

## Lift arm

ZK-QH	Z-bar linkage with quick hitch, standard lift arm length
ZK-QH-HL	Z-bar linkage with quick hitch, High Lift

## Bucket

STD	Liebherr bucket with straight base
LMB	Light material bucket
4in1	4 in 1 bucket

## Bulk material densities and bucket filling factors

Material	Condition	t/m³	%
Gravel	moist	1.9	105
	dry	1.6	105
	crushed stone	1.5	100
Sand	dry	1.5	105
	wet	1.9	110
Gravel and Sand	dry	1.7	105
	wet	2.0	100
Sand / Clay		1.6	110
Clay	natural	1.6	110
	dry	1.4	110
Clay / Gravel	dry	1.4	110
	wet	1.6	100
Earth	dry	1.3	115
	wet excavated	1.6	110
Topsoil		1.1	110
Basalt		1.95	100
Granite		1.8	95
Sandstone		1.6	100
Slate		1.75	100
Bauxite		1.4	100
Limestone		1.6	100
Gypsum	broken	1.8	100
Coke		0.5	110
Slag	broken	1.8	100
Glass waste	broken	1.4	100
	solid	1.0	100
Compost	dry	0.8	105
	wet	1.0	110
Wood chips / Saw dust		0.5	110
Paper	shredded / loose	0.6	110
	recovered paper / cardboard	1.0	110
Coal	heavy material density	1.2	110
	light material density	0.9	110
Waste	domestic waste	0.5	100
	bulky waste	1.0	100

# Tyres



## Tyre types

	Size and tread code		Change of operating weight kg	Width over tyres mm	Change in vertical dimensions* mm	Use
<b>L 507 E</b>						
Goodyear	405/70R20 Powerload	L2	55	1,960	22	Sand, Gravel, Asphalt (all ground conditions)
Firestone	400/70R20 Duraforce UT	L3	66	1,950	18	Gravel, Asphalt, Industry (all ground conditions)
Firestone	400/70R20 R8000 UT	L2	43	1,950	18	Earthworks, Green area (all ground conditions)
Michelin	400/70R20 BIBLOAD	L3	40	1,950	13	Gravel, Asphalt, Industry (firm ground conditions)
Michelin	400/70R20 XMCL	L2	56	1,960	19	Earthworks, Green area (all ground conditions)
Mitas	405/70R18 EM-01	L2	0	1,960	0	Gravel, Asphalt (all ground conditions)
Mitas	405/70R20 EM-01	L2	36	1,960	25	Gravel, Asphalt (all ground conditions)
Nokian	400/70R20 Hakkapeliitta TRI	L2	56	1,950	23	Winter tyres, Gravel, Asphalt (all ground conditions)
Trelleborg	400/70R20 TH400	L2	50	1,950	13	Earthworks, Green area (all ground conditions)

\* The stated values are theoretical and may deviate in practice.

Before operating the vehicle with tyre foam filling or tyre protection chains, please discuss this with the Liebherr-Werk Bischofshofen GmbH.

# Tipping load



## What is tipping load?

Load at centre of gravity of working equipment, so that the wheel loader just begins to tip over the front axle. This is the most unfavourable static-load position for the wheel loader. Lifting arms horizontal, wheel loader fully articulated at centre pivot.

## Pay load.

The pay load must not exceed 50% of the tipping load when articulated. This is equivalent to a static stability-margin factor of 2.0.

## Bucket capacity.

The bucket volume is determined from the pay load.

$$\text{Pay load} = \frac{\text{Tipping load, articulated}}{2}$$

$$\text{Bucket capacity} = \frac{\text{Pay load (t)}}{\text{Specific bulk weight of material (t/m}^3\text{)}}$$

# The Liebherr wheel loader

## Wheel loader



		L 507 E
Tipping load	kg	3,750
Bucket capacity	m <sup>3</sup>	0.9
Operating weight	kg	5,910
Battery	kWh	32.2 / 64.4

11.23

# Equipment

## Basic wheel loader

32.2 kWh lithium-ion battery	●
64.4 kWh lithium-ion battery	+
Automatic central lubrication system	+
Combined inching-braking system	●
Connection for electrical equipment 7-pole	+
Guard for headlights	+
Liebherr biodegradable hydraulic oil	+
Load lashing lugs	●
Lockable doors and engine hood	●
On-board AC charging technology up to 400 V / 32 A	●
On-board AC charging technology up to 400 V / 32 A and DC charging technology up to 65 kW	+
on-board tool kit	●
Parking brake	●
Power socket rear (13-pole, 12V)	+
Rear license panel light	+
Ride control	+
Special paint	+
Spedder version	+
Towing hitch	+
Tractive force adjustment	+
Travel light on front section LED	●
Type 2 IP67 charging cable, CEE plug, adjustable charging power 3.5 – 22 kW	+
Variable speed limit and fixed speed	+



## Equipment

1st and 2nd electro-hydraulic, proportional additional function	+
1st electro-hydraulic, proportional additional function	+
Continuous mode, additional function	+
Float position	●
Fork carrier and pallet forks	●
High-dump bucket	+
Hydraulic quick hitch	●
Hydraulic quick hitch Solidlink	+
Leak oil line	+
Lift arm Z-bar linkage	●
Light material bucket	+
Loading buckets incl. a range of cutting tools	+
Pipe break protection	+
Preparation for hydraulic quick hitch Solidlink (quick hitch without Solidlink block)	+
Programmable automatic lifting and lowering	+
Tilt cylinder protection	+
Unpressurised return flow	+
Working hydraulics lockout	●

- = Standard
- + = Option
- = not available
- \* = activation required free of charge

Here you can download our wheel loader brochures:



## Cab

3 way continuously adjustable steering column (height-adjustable, tilting, folding)	+
Air conditioning system	+
Amber beacon LED	+
Clothes hook	●
Electronical theft protection with code	+
Emergency exit	●
Exterior mirror, tiltable	●
Exterior mirror, tiltable and heatable	+
Fire extinguisher in cab 2 kg	+
First aid kit	+
Floor mat	●
Fold-out window right 180°	●
Headlights front, double design, LED	+
Headlights front, single design, LED	●
Headlights rear, double design, LED	+
Headlights rear, single design, halogen / LED	+
Hot-water heater with defroster and recirculated air mode	●
Interior rear-view mirror	●
Liebherr Connect	
MyLiebherr Maintenance	+
MyLiebherr Performance	+
MyLiebherr Portal*	●
Liebherr control lever with mini-joystick for 1st and 2nd hydraulic, proportional additional function moving with operator's seat (incl. travel direction)	●
Operating hour meter (integrated in display unit)	●
Operator seat "Comfort" – air sprung with seat heating	+
Operator seat "Standard" – mechanically sprung	●
Particle filter F5	●
Power socket 12V	●
Premium display (Touchscreen), with height adjustment and tilting function	●
Preparation for radio installation	+
Radio Liebherr "Comfort" (DAB+ / USB / AUX / BLUETOOTH / handsfree set)	+
Radio Liebherr "Standard" (USB / AUX)	+
Rear window heated electrically	●
Sliding window left	+
Soundproof ROPS / FOPS cab	●
Steering column fixed	●
Steering column folding	+
Storage box	●
Storage compartment	●
Sunblind front	●
Sunblind front / rear	+
Wide angle mirror	+
Windscreen guard	+
Wipe system front / rear	●



## Safety

Back-up alarm acoustical/visual	+
Country-specific versions	+
Rear space monitoring with camera (integrated in display unit)	+

