



User Guide

Quality, Design and Innovation



[home.liebherr.com/fridge-manuals](http://home.liebherr.com/fridge-manuals)









# LIEBHERR

# General safety instructions

## Contents

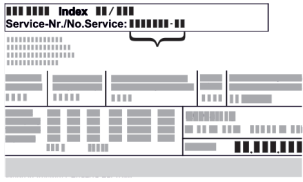
<b>1</b>	<b>General safety instructions.....</b>	<b>2</b>
<b>2</b>	<b>Appliance at a glance.....</b>	<b>4</b>
2.1	Scope of delivery.....	4
2.2	Overview of the appliance and equipment.....	4
2.3	SmartDevice.....	4
2.4	Appliance range of use.....	4
2.5	Conformity.....	5
2.6	Spare parts.....	5
<b>3</b>	<b>Functionality of the Touch display.....</b>	<b>5</b>
3.1	Navigation and symbol explanation.....	5
3.2	Menus.....	5
3.3	Sleep mode.....	6
<b>4</b>	<b>Putting into operation.....</b>	<b>6</b>
4.1	Switching on appliance (first use).....	6
<b>5</b>	<b>Storage.....</b>	<b>6</b>
5.1	Information regarding storage.....	6
5.2	Storage sketch.....	6
<b>6</b>	<b>Saving energy.....</b>	<b>7</b>
<b>7</b>	<b>Controls.....</b>	<b>7</b>
7.1	Control and display elements.....	7
7.1.1	Status display.....	7
7.1.2	Display symbols.....	7
7.1.3	Acoustic signals.....	7
7.2	Appliance functions.....	7
7.2.1	Notes on the appliance functions.....	7
7.2.2	Switching appliance on and off .....	8
7.2.3	WiFi .....	8
7.2.4	Temperature .....	9
7.2.5	Temperature unit .....	9
7.2.6	SabbathMode .....	9
7.2.7	HumiditySelect .....	10
7.2.8	Lighting intensity *.....	10
7.2.9	Display brightness .....	11
7.2.10	Door alarm .....	11
7.2.11	Light alarm *.....	11
7.2.12	Alarm Sound.....	12
7.2.13	Key Sound.....	12
7.2.14	Display lock .....	12
7.2.15	Display PIN .....	13
7.2.16	Language .....	14
7.2.17	Appliance and software information .....	14
7.2.18	Reminder .....	14
7.2.19	Demo mode .....	15
7.2.20	Resetting to factory settings .....	16
7.3	Messages.....	16
7.3.1	Warnings.....	16
7.3.2	Reminder.....	17
<b>8</b>	<b>Features.....</b>	<b>17</b>
8.1	Wooden grid.....	17
8.2	Labels.....	19
<b>9</b>	<b>Maintenance.....</b>	<b>19</b>
9.1	FreshAir activated carbon filter.....	19
9.2	Cleaning the appliance.....	20
<b>10</b>	<b>Customer help.....</b>	<b>20</b>
10.1	Technical specifications.....	20
10.2	Operating noises.....	20
10.3	Technical fault.....	21
10.4	Customer Service.....	22
10.5	Model plate.....	22
<b>11</b>	<b>Shutting down.....</b>	<b>22</b>
<b>12</b>	<b>Disposal.....</b>	<b>22</b>
12.1	Preparing the appliance for disposal.....	22
12.2	Disposing of the appliance in an environmentally friendly manner.....	22

The manufacturer is continually working on the further development of all types and models. Please be aware that we reserve the right to make changes to the shape, equipment and technology.

Symbol	Explanation
	<b>Read instructions</b> Please read the information in these instructions carefully to understand all of the benefits of your new appliance.
	<b>Additional information on the Internet*</b> The digital manual with additional information can be found via the QR code on the front of the manual or by entering the service number at <a href="http://home.liebherr.com/fridge-manuals">home.liebherr.com/fridge-manuals</a> . The service number can be found on the serial tag:*
	
	<i>Fig. Example illustration*</i>
	<b>Check appliance</b> Check all parts for transport damage. If you have any complaints, please contact your agent or customer service.
	<b>Differences</b> These instructions apply to a range of models, so differences are possible. Sections that apply to certain models only are marked with an asterisk (*).
	<b>Instructions and results</b> Instructions are marked with a ▶. Results are marked with a ▷.
	<b>Videos</b> Videos about the appliances are available on the YouTube channels of Liebherr-Hausgeräte.

### Open source licences:

The appliance contains software components that use open source licences. Information on the open source licences used can be found here: [home.liebherr.com/open-source-licences](http://home.liebherr.com/open-source-licences)

These operating instructions apply to:

UWgb 3631

## 1 General safety instructions

Please keep these instructions in a safe place and pass them on to any subsequent owners.\*

Read these operating instructions carefully before use to ensure safe and correct use of the appliance. Follow the instructions, safety instructions and warning messages included at all times. They are important for ensuring you can operate and install the appliance safely and without any problems.

### Danger for the user:

- This device can be used by children and people with impaired physical, sensory or mental abilities or with a lack of experience and knowledge provided that they are

supervised or have received instruction in the safe use of this device, and about the resulting hazards.

Children must not play with this appliance. Cleaning and user maintenance work must not be carried out by children without adult supervision. Children aged between 3 and 8 are allowed to load and unload the appliance. Children below the age of 3 must be kept away from the appliance unless they are under continuous adult supervision.

- The socket must be easily accessible so that the appliance can be disconnected quickly from the electricity in an emergency. It must not be located in the area behind the appliance.
- When disconnecting the appliance from the supply, always take hold of the plug. Do not pull the cable.
- In the event of a fault pull out the mains plug or deactivate the fuse.
- Do not damage the mains power cable. Do not operate the appliance with a defective mains power cable.
- If the supply cord is damaged, it must be replaced by a special cord or assembly available from the manufacturer or its service agent.\*
- Only customer service or other specially trained staff may repair or perform other operations on the appliance.
- Only install, connect and dispose of the appliance according to the instructions.
- Only use the appliance when is installed.
- Special lights, such as LED lights on the appliance, are used to illuminate the interior of the appliance and are not suitable for room lighting.\*

#### Fire hazard:

- This appliance contains a refrigerant which is environmentally friendly, but flammable. Leaking refrigerant may ignite. It is hazardous for anyone other than an Authorised Service Person to service this appliance. In Queensland, the authorised Service Person MUST hold a Gas Work Authorisation for hydrocarbon refrigerants, to carry out Servicing or repairs where the gas system is being opened or charged.\*
- The coolant used (information on the model plate) is ecofriendly but also flammable. Any leaking coolant may ignite.
  - Do not damage the refrigerant circuit pipes.
  - Do not handle ignition sources inside the appliance.
  - Do not use electrical appliances inside the appliance (e.g. steam cleaners, heaters, ice cream makers, etc.).
  - If the refrigerant leaks: remove any naked flames or ignition sources from the vicinity of the leakage point. Properly air the room. Inform customer services.
- Do not store explosives or sprays using combustible propellants such as butane, propane, pentane, etc. in the appliance. To identify these spray cans, look for the list of contents printed on the can, or a flame symbol. Gases possibly escaping may ignite due to electrical components.
- Keep burning candles, lamps and other items with naked flames away from the appliance so that they do not set the appliance on fire.
- **WARNING:** Keep ventilation openings, in the appliance enclosure or in the built-in structure, clear of obstruction.\*
- **WARNING:** Do not use mechanical devices or other means to accelerate the defrosting process, other than those recommended by the manufacturer.\*
- **WARNING:** Do not damage the refrigerant circuit.\*
- Please be sure to store alcoholic drinks or other packaging containing alcohol in tightly closed containers. Any alcohol that leaks out may be ignited by electrical components.

#### Danger of tipping and falling:

- Do not misuse the plinth, drawers, doors etc. as a step or for support. This applies particularly to children.

#### Danger of food poisoning:

- Do not consume food which has been stored too long.

#### Danger of frostbite, numbness and pain:

- Avoid prolonged skin contact with cold surfaces or refrigerated/frozen goods or take protective measures, e.g wear gloves.
- Do not consume ice cream, water ice or ice cubes immediately and do not consume them too cold.\*

#### Danger of injury and damage:

- Hot steam can lead to injury. Do not use electrical heating or steam cleaning equipment, open flames or defrosting sprays to defrost.
- Do not use sharp implements to remove the ice.

#### Risk of crushing:

- Do not hold the hinge when opening and closing the door. Fingers may get caught.

#### Symbols on the appliance:



This symbol may be located on the compressor. It relates to the oil in the compressor and makes reference to the risk that: Swallowing or inhaling can be fatal. This advice is only relevant to recycling. There is no danger in normal operation.



This symbol is located on the compressor and indicates the danger of flammable materials. Do not remove the sticker.



This or a similar sticker may be located on the rear of the appliance. This sticker indicates that there are vacuum insulation panels (VIP) or perlite panels in the door and/or housing. This advice is only relevant to recycling. Do not remove the sticker.

#### Please note the warning messages and other specific advice in the other chapters:

	DANGER	indicates an immediately hazardous situation which will lead to death or serious injuries if it is not avoided.
	WARNING	indicates a hazardous situation which may lead to death or serious injuries if it is not avoided.
	CAUTION	indicates a hazardous situation which may lead to minor or moderate injuries if it is not avoided.
	NOTICE	indicates a hazardous situation which may lead to damage to property if it is not avoided.
	Note	indicates useful instructions and tips.

# Appliance at a glance

## 2 Appliance at a glance

### 2.1 Scope of delivery

Check all parts for transport damage. Contact your dealer or customer service in the event of complaints. (see 10.4 Customer Service)

Your new appliance comes with the following parts:

- Built-in appliance
- Features (depending on the model)
- Installation materials (depending on the model)
- "Quick Start Guide"\*
- "Installation Guide"\*

### 2.2 Overview of the appliance and equipment

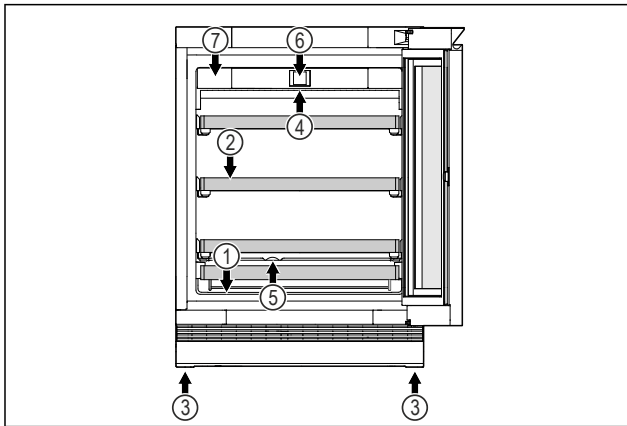

Fig. 1 Example illustration, front end

#### Equipment

- |                       |                                      |
|-----------------------|--------------------------------------|
| (1) Type plate        | (5) Condensation drainage            |
| (2) Shelves           | (6) Controls and temperature display |
| (3) Adjustable foot   | (7) FreshAir activated carbon filter |
| (4) Interior lighting |                                      |

### 2.3 SmartDevice

SmartDevice is the networking solution for your wine storage cabinet.

If your appliance SmartDevice-enabled or compatible, you can quickly and easily connect your appliance to your WiFi. With the SmartDevice app, you can operate your appliance from a mobile device. Additional functions and setting options are available in the SmartDevice SmartDevice app.

SmartDevice-enabled appliance:\*

Your appliance is capable of being a SmartDevice. To be able to connect your device to WiFi, you need to download the SmartDevice app.\*

SmartDevice-compatible appliance:\*

Your appliance is compatible for use with the SmartDeviceBox. You must first purchase and install the SmartDeviceBox. In order to connect your appliance to the WiFi, you need to download the SmartDevice app.\*

More information about SmartDevice:

[smartdevice.liebherr.com](http://smartdevice.liebherr.com)

Purchasing the SmartDeviceBox in the Liebherr-Hausgeräte store:\*

[home.liebherr.com/shop/de/deu/smartdevicebox.html](http://home.liebherr.com/shop/de/deu/smartdevicebox.html)\*

Downloading the SmartDevice app:



After installing and configuring the SmartDevice app, you can connect your appliance to your Wi-Fi (see 7.2.3 WiFi) using the SmartDevice app and the appliance's Wi-Fi function.

#### Note

The SmartDevice function is not available in the following countries: Russia, Belarus, Kazakhstan.

You cannot use the SmartDeviceBox.\*

\*

### 2.4 Appliance range of use

#### Intended use

The appliance is only suitable for storing wine in a domestic or domestic-like environment. This includes, for example, using\*

- in staff kitchens, bed and breakfast establishments,\*
- by guests in country houses, hotels, motels and other accommodation,\*
- for catering and similar services in the wholesale trade.\*

The appliance is not suitable for freezing food;

The appliance is suitable for integrating under counters.

All other types of use are not permitted.

#### Foreseeable misuse

The following applications are expressly forbidden:

- Storing and refrigerating medicines, blood plasma, laboratory preparations or similar substances and products based on the Medical Device Directive 2007/47/EC\*
- Use in outdoor areas with very high humidity
- Use in areas at risk of explosions

Misusing the appliance may lead to damage to the goods stored or they may spoil.

#### Climate classifications

Depending on the climate classification the appliance is designed to operate in restricted ambient temperatures. The climate classification applying to your appliance is printed on the rating plate.

#### Note

► Keep to the specified ambient temperatures in order to guarantee that the appliance works properly.

Climate classification	for ambient temperatures of
SN	10 °C to 32 °C
N	16 °C to 32 °C
ST	16 °C to 38 °C
T	16 °C to 43 °C
SN-ST	10 °C to 38 °C

Climate classification	for ambient temperatures of
SN-T	10 °C to 43 °C

## 2.5 Conformity

The refrigerant circuit has been tested for leaks. When installed, the appliance complies with the applicable safety regulations and with the corresponding directives.

For the EU market:\* The appliance complies with directive 2014/53/EU.\*

For the GB market:\* The appliance complies with Radio Equipment Regulations 2017 SI 2017 No. 1206.\*

The full text of the EU Declaration of Conformity is available on the following website: [www.Liebherr.com](http://www.Liebherr.com)\*

## 2.6 Spare parts





The spare parts availability for functional parts and stockable parts of the equipment is 15 years.



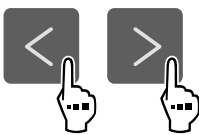

## 3 Functionality of the Touch display

You operate your appliance using the Touch display. You select appliance functions in the Touch display (hereafter referred to as display) by tapping them. If you do not perform any action on the display for 10 seconds, the display either jumps back to the higher-level menu or directly to the status display.

### 3.1 Navigation and symbol explanation

In the illustrations, different symbols are used to navigate the display. The following table describes these symbols.

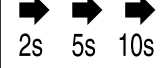
Symbol	Description
	<b>Press the Next navigation arrow:</b> Navigates to the next option in the menu.
	<b>Press the Back navigation arrow:</b> Jumps back one option in the menu.
	<b>Press and hold the Back navigation arrow for 3 seconds:</b> Jumps back to the status display in the main menu or from the Settings menu.
	<b>Press the navigation arrow several times in succession:</b> Navigates in the menu to the desired function.
	<b>Press the Confirm symbol:</b> Activates/deactivates function. Opens submenu.

Symbol	Description
	<b>Press the Confirm symbol together with the back icon:</b> Jumps back one menu level.
	<b>Arrow with clock:</b> It takes more than 10 seconds for the following message to appear in the display.
	<b>Arrow with a time indication:</b> It takes the specified amount of time until the following message appears in the display.
	<b>“Open Settings menu” symbol:</b> Navigates to the Settings menu and opens the settings menu. If necessary: Navigate to the desired function in the Settings menu. (see 3.2.1 Opening the Settings menu)
No action for 10 seconds	If you do not perform any action on the display for 10 seconds, the display either jumps back to the higher-level menu or directly to the status display.
Close the door and open it again.	If you close the door and immediately open it again, the display jumps directly back to the status display.

Note: Illustrations of the display are shown in the English version.

### 3.2 Menus

The appliance functions can be found in various menus.

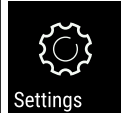
Menu	Description
Main menu	When you switch the appliance on, you are automatically in the main menu. From here you can navigate to the most important appliance functions, to the Settings menu and to the Advanced menu.
 Settings menu	The Settings menu contains additional appliance functions for setting up your appliance. (see 3.2.1 Opening the Settings menu)

#### 3.2.1 Opening the Settings menu

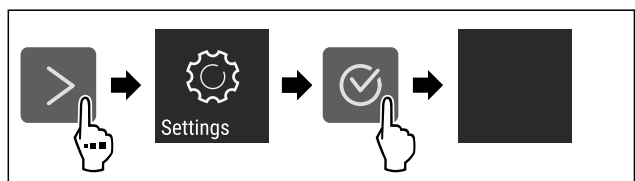

Fig. 2 Example illustration

- ▶ Carry out action steps according to the illustration.
- ▶ Settings menu is open.
- ▶ If necessary: Navigate to the desired function.

# Putting into operation

## 3.3 Sleep mode

If you do not touch the display for 1 minute, the display switches to sleep mode. In sleep mode, the display brightness is dimmed.

### 3.3.1 Ending sleep mode

- ▶ Press any navigation key.
- ▶ Sleep mode is ended.

## 4 Putting into operation

### 4.1 Switching on appliance (first use)

Make sure the following prerequisites are met:

- Appliance is installed and connected.
- All adhesive strips, adhesive and protective films and transport locks are removed from inside and outside the appliance.

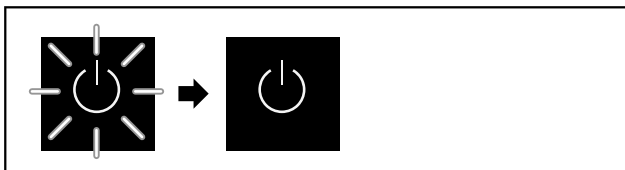

Fig. 3 Example illustration

The standby symbol flashes until the startup process is complete.

The standby symbol is shown in the display.

If the appliance has been supplied with factory settings, the screen language first needs to be selected when using for the first time.

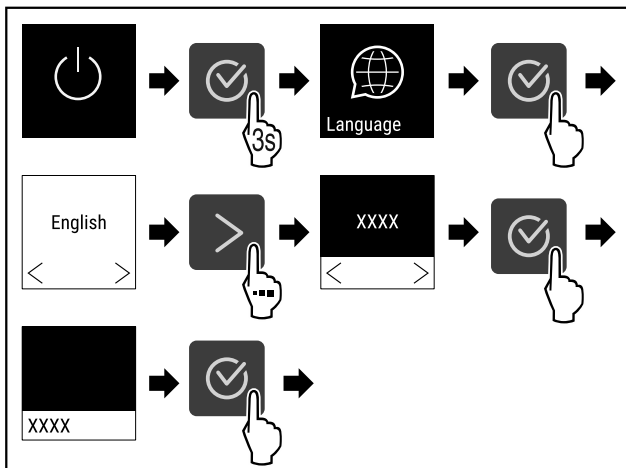

Fig. 4

- ▶ Carry out action steps according to the illustration.

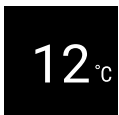

Fig. 5

- ▶ The appliance cools to the target temperature set at the factory.

## 5 Storage

### 5.1 Information regarding storage



#### WARNING

Fire hazard from electrical appliances!

If you use electrical appliances in the food area of your appliance, they can cause a fire.

- ▶ Do not use electrical appliances in the food area of the appliance unless recommended by the manufacturer.

#### Note

The energy consumption increases and the cooling power goes down if ventilation is not sufficient.

- ▶ Always keep air slots clear.

Observe the following specifications for storage:

- Keep the air vents on the fan free.

### 5.2 Storage sketch

#### 5.2.1 UWgb 3631

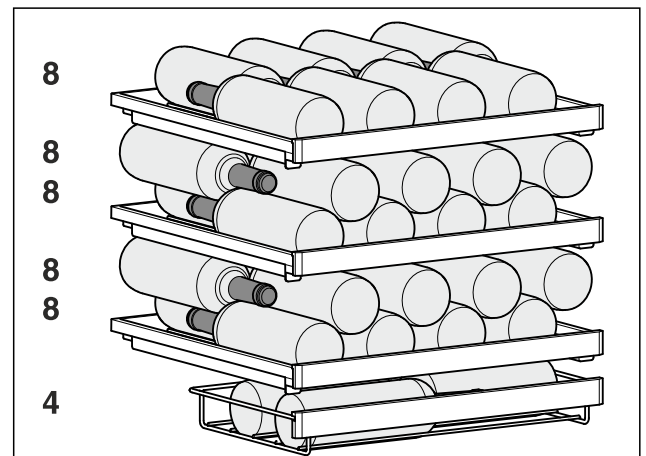

Fig. 6 Total 44 bottles (0.75 l Bordeaux bottles as per standard NF H 35-124)

#### 5.2.2 Using the bottle holder\*

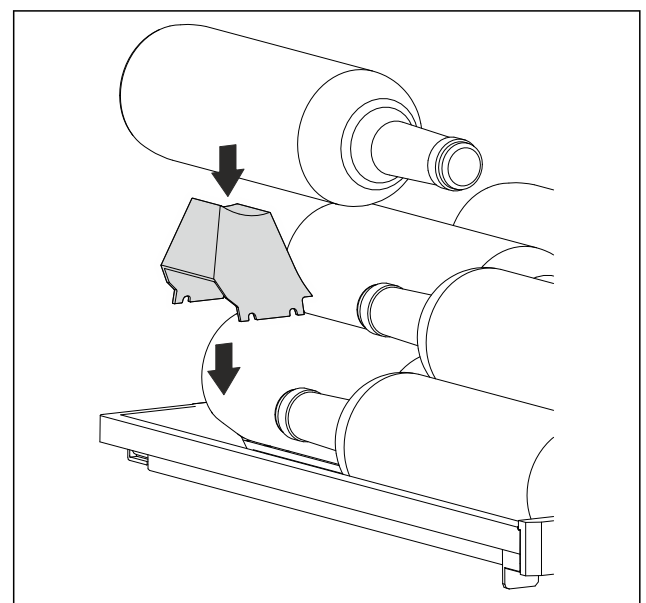

Fig. 7

## 6 Saving energy

- Pay attention to good ventilation. Do not cover ventilation holes or grids.\*
- Always keep the fan air slits clear.
- Do not install the appliance in direct sunlight or near radiators or similar sources of heat.
- If the appliance is installed directly next to an oven, the energy consumption may increase slightly. This is dependent on the service life and usage intensity of the oven.
- Energy consumption depends on the installation conditions, e.g. the ambient temperature (see 2.4 Appliance range of use) . A warmer ambient temperature can increase the energy consumption.
- Open the appliance for as short a time as possible.
- The lower the temperature is set the higher the energy consumption.

## 7 Controls

### 7.1 Control and display elements

The display provides a quick overview of the current appliance status, the temperature setting, the status of functions and settings as well as alarm and error messages. It is operated using the navigation arrows and confirmation symbol.

Functions can be activated or deactivated and setting values can be changed.

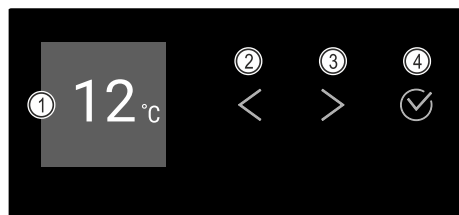

Fig. 8 Display

- |                                |                               |
|--------------------------------|-------------------------------|
| (1) Status display             | (3) Forwards navigation arrow |
| (2) Backwards navigation arrow | (4) Confirm                   |

#### 7.1.1 Status display

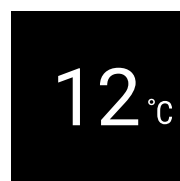

Fig. 9 Status display with temperature

The status display shows the temperature and is the home display. You navigate from here to the other functions and settings. The status display may show a range of display symbols.

#### 7.1.2 Display symbols

Display symbols provide information about the status of the appliance.

Symbol	Appliance status
	<b>Standby</b> Appliance is switched off.

Symbol	Appliance status
	<b>Flashing standby symbol</b> Appliance is starting up.
	<b>Flashing temperature</b> Target temperature not yet reached. Appliance cooling to temperature set.
	<b>Temperature display</b>
	<b>D in the display</b> Appliance is in DemoMode.
	<b>Flashing symbol</b> A fault is still active.
	<b>Error symbol</b> Appliance is in error state.
	<b>White bar at the bottom</b> Submenu
	<b>White background</b> Default, active setting or active value
	<b>Increasing bar</b> Press button for 3 seconds to activate setting.
	<b>Decreasing bar</b> Press button for 3 seconds to deactivate setting.

Status display symbols

#### 7.1.3 Acoustic signals

A signal sounds in the following cases:

- If a function or a value is confirmed.
- If a function or a value can either not be activated or not deactivated.
- As soon as an error occurs.
- If there is an alarm message.

The alarms can be switched on and off in the customer menu.

## 7.2 Appliance functions

### 7.2.1 Notes on the appliance functions

The appliance functions are set at the factory so that your appliance is fully functional.

# Controls

Before you alter, activate or deactivate the device functions, make sure that the following requirements are met:

- ❑ You have read and understood the descriptions of how the display works. (see 3 Functionality of the Touch display)
- ❑ You have familiarised yourself with the operating and display elements of your appliance. (see 7.1 Control and display elements)

## 7.2.2 Switching appliance on and off



Using this setting the entire appliance can be switched on and off.

### Switching on appliance

Without activated DemoMode:

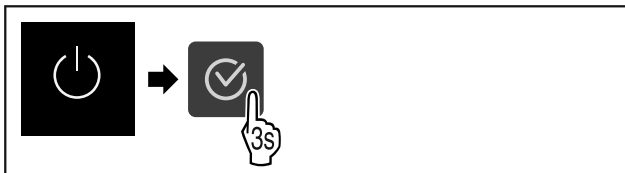

Fig. 10

► Carry out action steps according to the illustration.

With activated DemoMode:

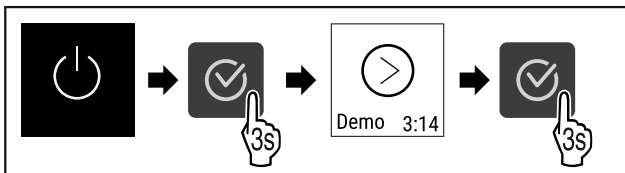

Fig. 11

► Carry out action steps according to the illustration.

### Note

Deactivate DemoMode before countdown finishes.



Fig. 12

► The temperature appears in the display.

### Switching off appliance



Fig. 13

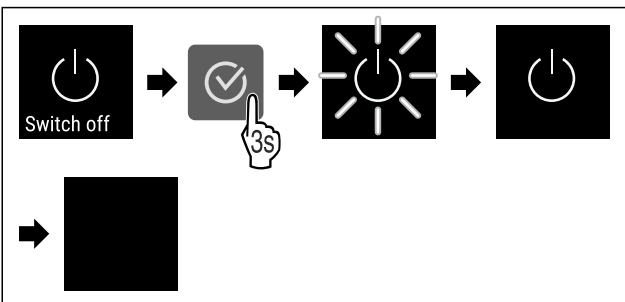

Fig. 14

- Carry out action steps according to the illustration.
- Standby symbol is shown in the display.
- Display switches off after approximately 10 minutes.

## 7.2.3 WiFi



Use this function to connect your appliance to WiFi. You can then operate it via the SmartDevice app on a mobile device. You can also use this function to disconnect or reset the WiFi connection.

To connect your device to WiFi, you need the SmartDeviceBox.\*

More information on the SmartDevice: (see 2.3 SmartDevice)

### Note

The SmartDevice function is not available in the following countries: Russia, Belarus, Kazakhstan.

You cannot use the SmartDeviceBox.\*

### Establishing the WiFi connection for the first time

Make sure that the following requirements are fulfilled:

- ❑ You have purchased and inserted a SmartDeviceBox. (see 2.3 SmartDevice) \*
- ❑ You have installed the SmartDevice app (see [apps.home.liebherr.com](https://apps.home.liebherr.com)).
- ❑ Registration in the SmartDevice app is completed.

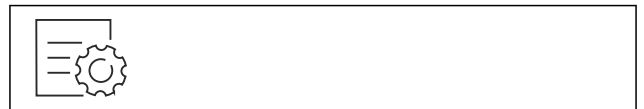

Fig. 15

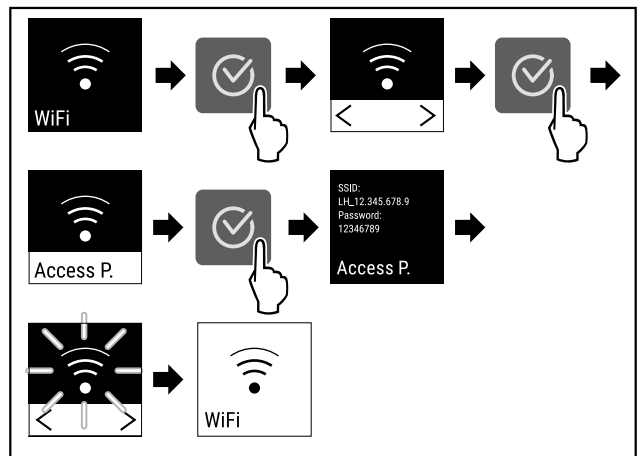

Fig. 16

- Carry out action steps according to the illustration.
- Connection is established.

### Disconnecting from the WiFi

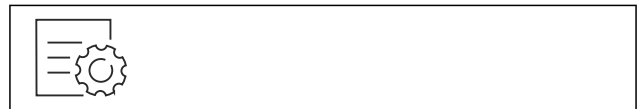

Fig. 17

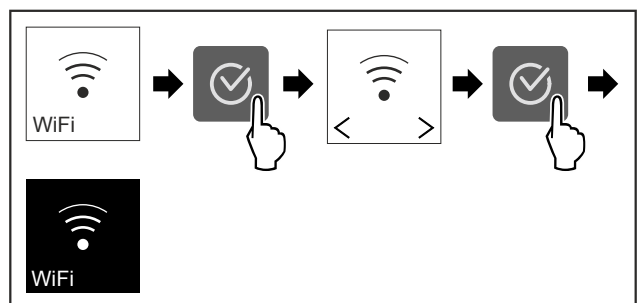

Fig. 18

- ▶ Carry out action steps according to the illustration.
- ▶ There is no connection.

## Resetting the WiFi connection



Fig. 19

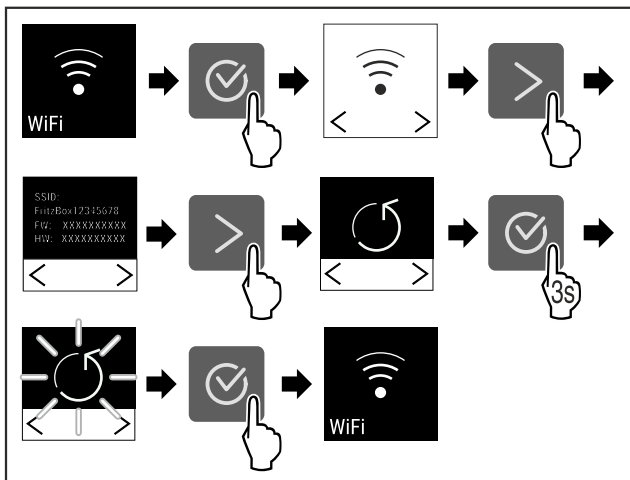

Fig. 20

- ▶ Carry out action steps according to the illustration.
- ▶ WiFi connection and other WiFi settings are reset to factory settings.

## Showing information about the WiFi connection

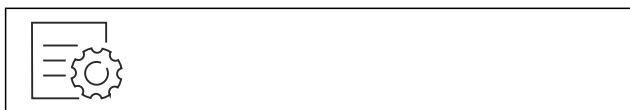

Fig. 21

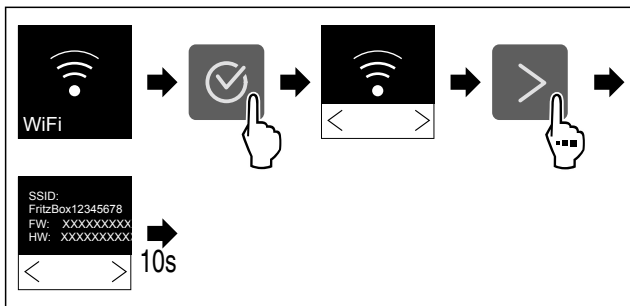

Fig. 22

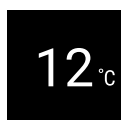

Fig. 23 Status display

- ▶ Carry out action steps according to the illustration.

## 7.2.4 Temperature

The temperature depends on the following factors:

- How often the door is opened
- How long the door is open for
- The room temperature of the installation site
- The type, temperature and amount of refrigerated items

## Setting temperature

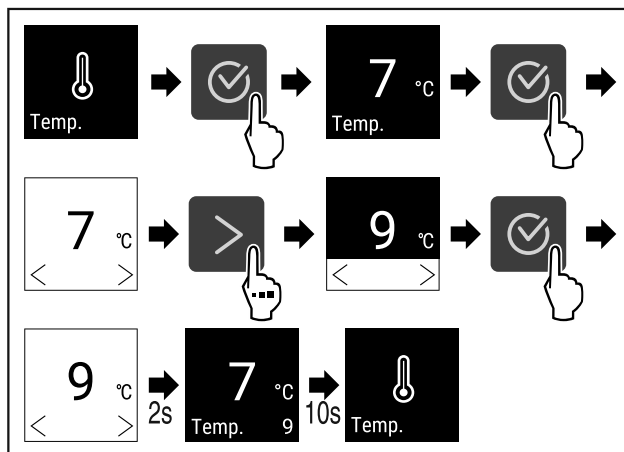

Fig. 24 Changing temperature from 7 °C to 9 °C

- ▶ Carry out action steps according to the illustration.
- ▶ Temperature is set.

## 7.2.5 Temperature unit

Use this function to set the temperature unit. You can set degrees Celsius or degrees Fahrenheit as the temperature unit.

### Setting the temperature unit



Fig. 25

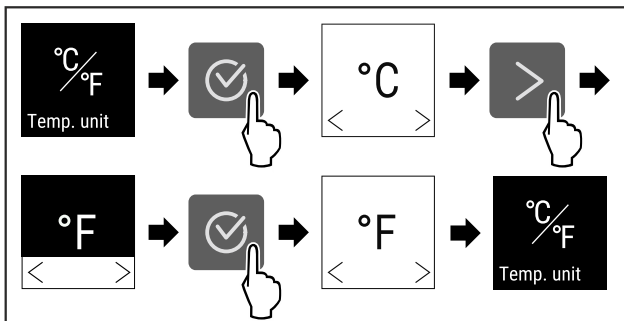

Fig. 26 Example illustration: Switch from degrees Celsius to degrees Fahrenheit.

- ▶ Carry out action steps according to the illustration.
- ▶ The temperature unit is set.

## 7.2.6 SabbathMode

You can use this function to activate or deactivate SabbathMode. If you activate this function, some electronic functions are switched off. As a result, your device meets the religious requirements for Jewish holidays such as Sabbath and complies with STAR-K Kosher certification.

Device status when SabbathMode is active
The status display shows SabbathMode permanently.
All functions on the display are locked except for the <b>Deactivate SabbathMode</b> function.
Active functions remain active.

# Controls

Device status when SabbathMode is active
The display remains bright when you close the door.
The interior lighting is deactivated.
Reminders are not implemented. The set time interval stops.
Reminders and warnings are not displayed.
There is no door alarm.
There is no temperature alarm.
After a power failure, the appliance returns to SabbathMode.

Device status

## Note

This appliance has certification from the "Institute for Science and Halacha". ([www.machonhalacha.co.il](http://www.machonhalacha.co.il))

You can find a list of STAR-K-certified appliances at [www.star-k.org/appliances](http://www.star-k.org/appliances).

## Activating SabbathMode

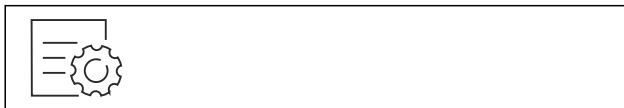

Fig. 27

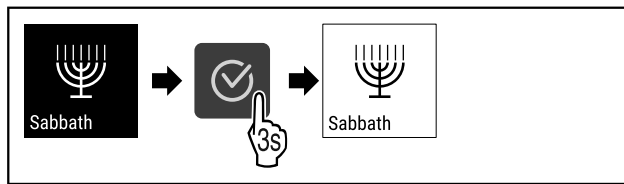

Fig. 28

- ▶ Carry out action steps according to the illustration.
- ▷ SabbathMode is activated.
- ▷ The status display shows SabbathMode permanently.

## Deactivating SabbathMode

The SabbathMode is automatically deactivated after 80 hours. However, you can also deactivate SabbathMode manually at any time:

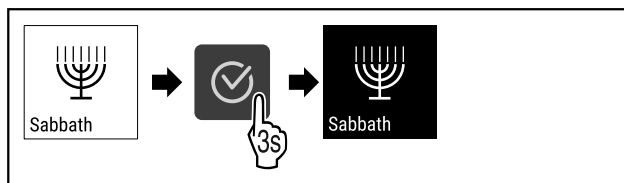

Fig. 29

- ▶ Carry out action steps according to the illustration.
- ▷ SabbathMode is deactivated.

## 7.2.7 HumiditySelect



Use this function to set the humidity inside your appliance. Setting the humidity correctly will have a positive effect on the structure of the corks during long-term storage and prevent them from drying out.

## Note

The frequency and duration for which the door is open influence the humidity in the appliance.

You can choose between two humidity settings:

HumiditySelect function	Temperature setting on the appliance	Application/energy consumption
Standard (preset)	10-12 °C	average humidity in the environment between 50-80% low energy consumption of the appliance
High	10-12 °C	average humidity in the environment < 50% energy consumption of the appliance increases

## Increasing the humidity in the appliance



Fig. 30

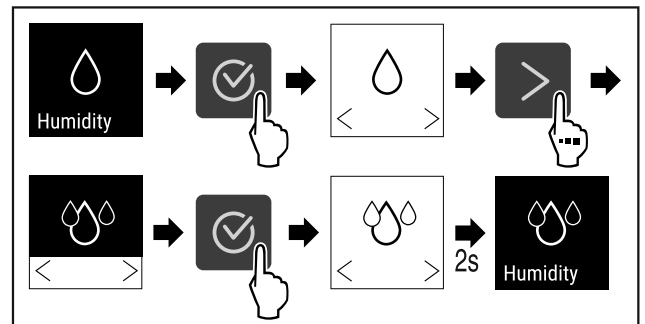

Fig. 31

- ▶ Carry out action steps according to the illustration.
- ▷ Humidity in the appliance increases.

## Setting the humidity in the appliance to standard



Fig. 32

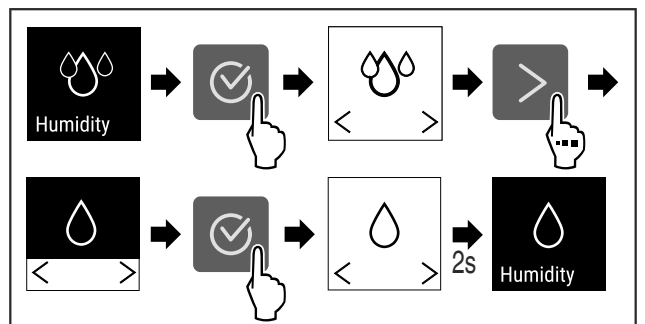

Fig. 33

- ▶ Carry out action steps according to the illustration.
- ▷ Humidity in the appliance decreases.

## 7.2.8 Lighting intensity



This setting allows the interior brightness to be adjusted incrementally.

The following brightness values can be set:

- Off
- 20%
- 40%
- 60%
- 80%
- 100% (default)

## Setting lighting intensity

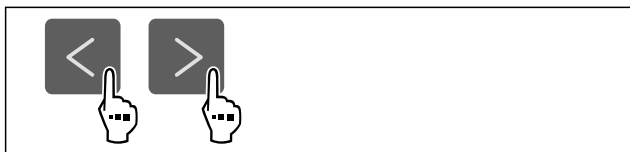

Fig. 34

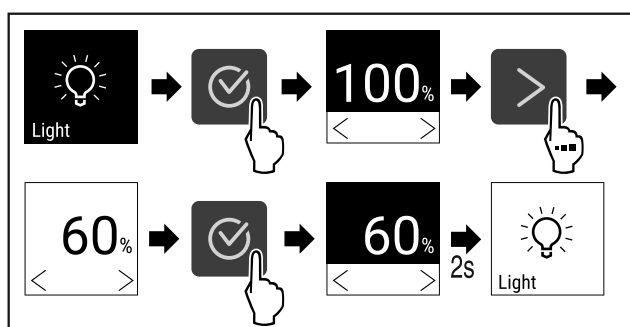

Fig. 35

- ▶ Carry out action steps according to the illustration.
- ▶ The lighting intensity increases or decreases accordingly.

## 7.2.9 Display brightness



Use this function to set the display brightness in stages.

You can select the following brightness levels:

- 20 %
- 40 %
- 60 %
- 80 %
- 100 % (pre-setting)

### Setting the brightness



Fig. 36

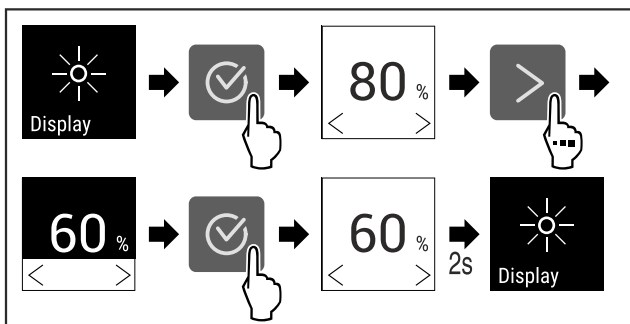

Fig. 37 Example illustration: Switch from 80 % to 60 %.

- ▶ Carry out action steps according to the illustration.
- ▶ The brightness is set.

## 7.2.10 Door alarm



Use this function to activate or deactivate the door alarm. The door alarm sounds if the door is open for too long. The door alarm is activated on delivery. You can set how long the door may be open before the door alarm sounds.

The following values can be set:

- 1 minute
- 2 minutes
- 3 minutes
- Off

### Setting the door alarm

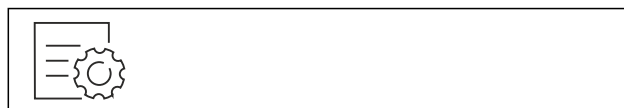

Fig. 38

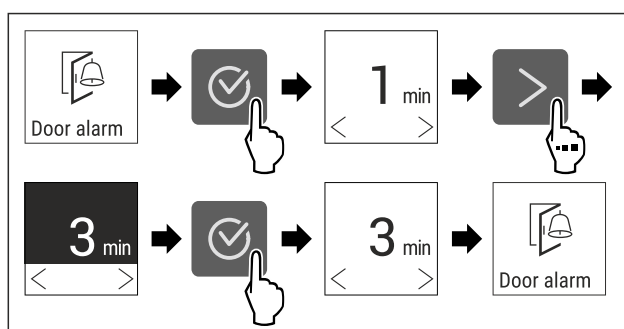

Fig. 39 Example illustration: Change door alarm from 1 minute to 3 minutes.

- ▶ Carry out action steps according to the illustration.
- ▶ The door alarm is set.

### Deactivating the door alarm



Fig. 41

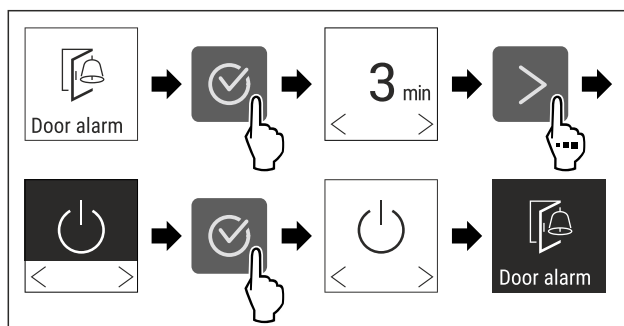

Fig. 42

- ▶ Carry out action steps according to the illustration.
- ▶ The door alarm is deactivated.

## 7.2.11 Light alarm



This setting allows the visual alarm messages in the display to also be emphasised by flashing appliance lighting.

# Controls

## Activating light alarm



Fig. 43

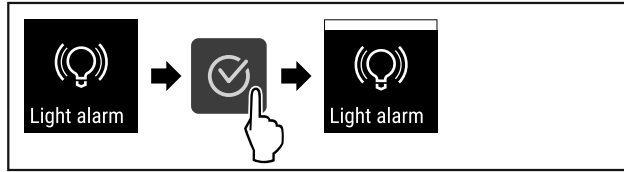

Fig. 44

- ▶ Carry out action steps according to the illustration.
- ▷ The light alarm is activated.

## Deactivating light alarm

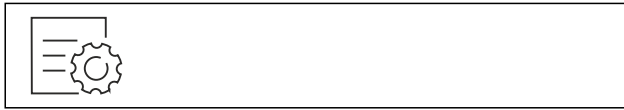

Fig. 45

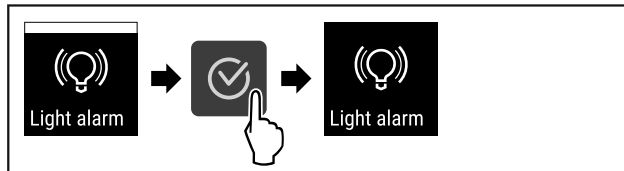

Fig. 46

- ▶ Carry out action steps according to the illustration.
- ▷ The light alarm is activated.



## 7.2.12 Alarm Sound

This function enables all alarm sounds, such as door alarm, to be switched on and off.

### Activating Alarm Sound



Fig. 47

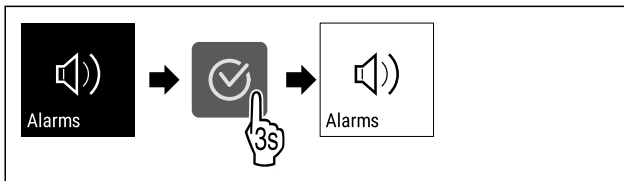

Fig. 48

- ▶ Carry out action steps according to the illustration.
- ▷ Alarm Sound is activated.

### Deactivating Alarm Sound

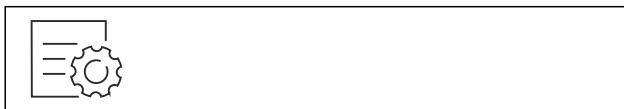

Fig. 49

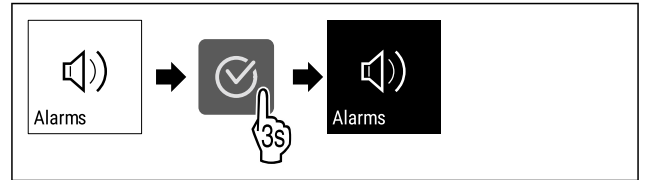

Fig. 50

- ▶ Carry out action steps according to the illustration.
- ▷ Alarm Sound is deactivated.



## 7.2.13 Key Sound

This function makes it possible to switch all confirmation sounds and the Startsound on and off.

### Activating Key Sound

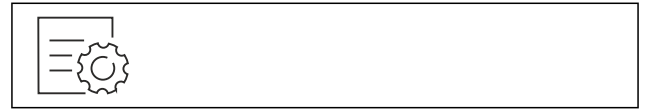

Fig. 51

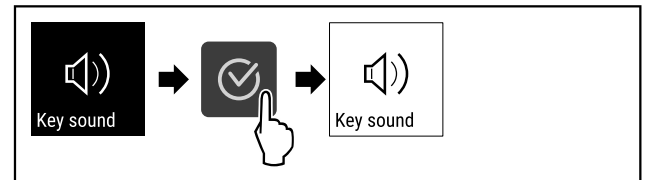

Fig. 52

- ▶ Carry out action steps according to the illustration.
- ▷ Key Sound is activated.

### Deactivating Key Sound



Fig. 53

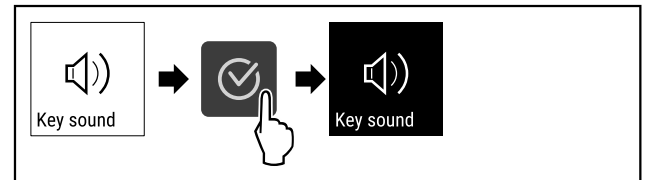

Fig. 54

- ▶ Carry out action steps according to the illustration.
- ▷ Key Sound is deactivated.



## 7.2.14 Display lock

This setting avoids accidental operation of the appliance.

Application:

- Prevent settings and functions being changed unintentionally.
- Prevent appliance being switched off unintentionally.
- Prevent temperature being set unintentionally.

### Activating the display lock



Fig. 55

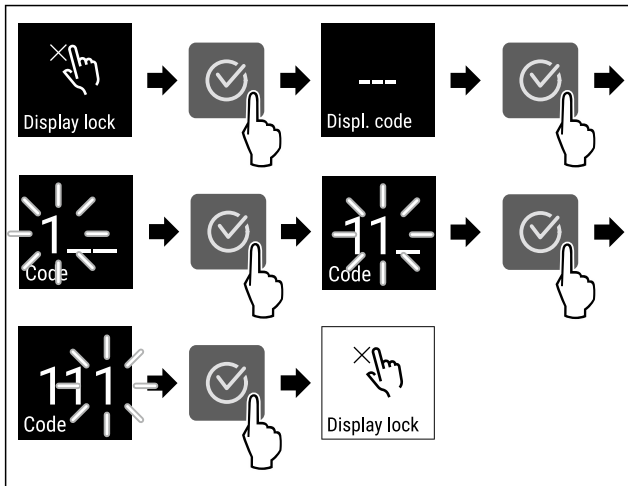

Fig. 56 Example uses the preset display code **111**.

- ▶ Carry out action steps according to the illustration.
- ▶ The display lock is activated.
- ▶ The status display appears.

### Unlocking the display lock for a short time

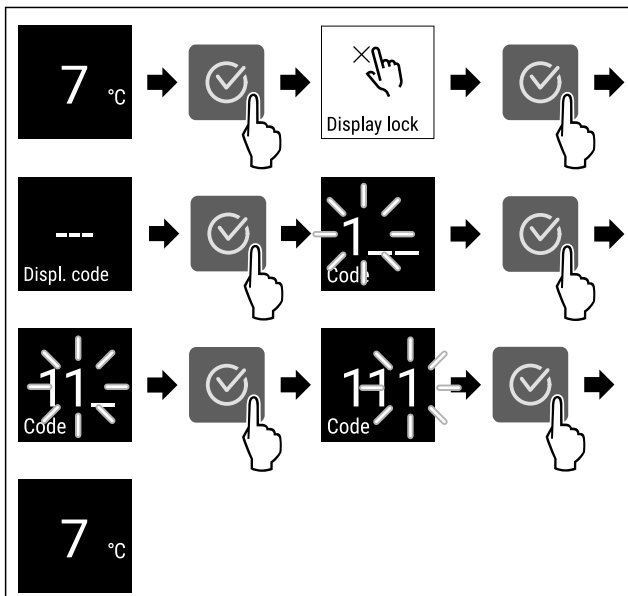

Fig. 57

- ▶ Carry out action steps according to the illustration.
- ▶ The display lock is deactivated.
- ▶ The status display appears.

### Deactivating the display lock

- ▶ Carry out action steps (see Unlocking the display lock for a short time) .



Fig. 58

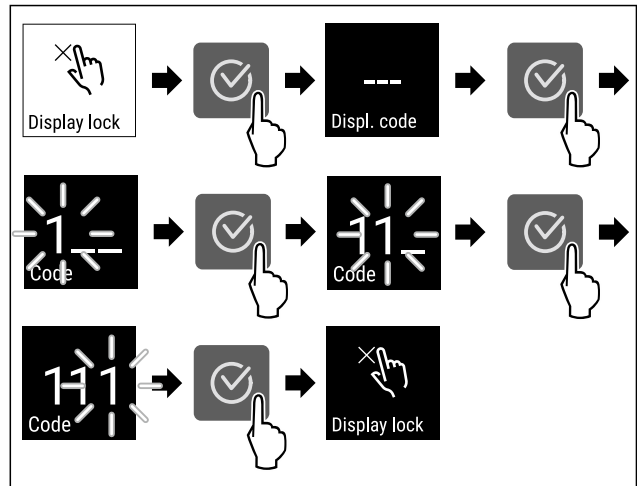

Fig. 59

- ▶ Carry out action steps according to the illustration.
- ▶ The display lock is deactivated.
- ▶ The status display appears.

### 7.2.15 Display PIN Displ. code

Use this function to change the display PIN. The display PIN is set to 111 on delivery. If you have forgotten the display PIN, you can reset the display PIN by resetting the appliance to the factory settings. (see 7.2.20 Resetting to factory settings )

#### Changing the display PIN

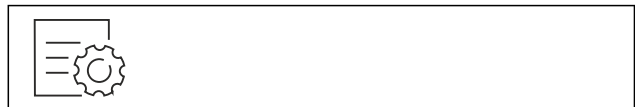

Fig. 60

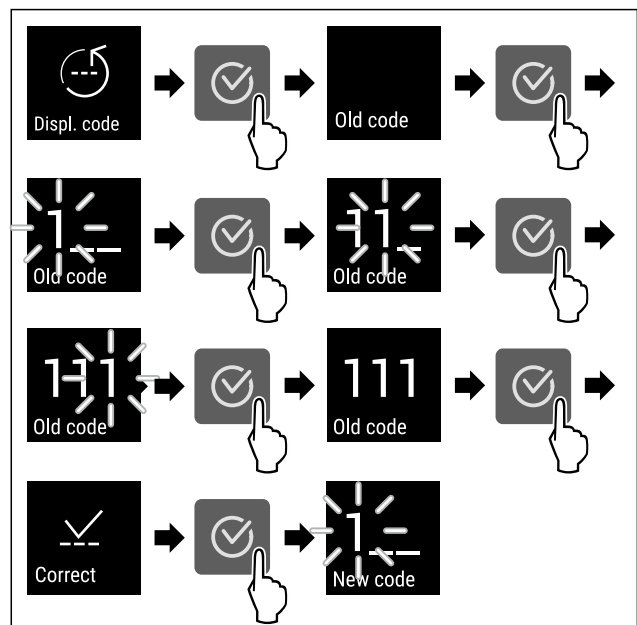

Fig. 61 Example illustration: Change display PIN from factory setting 111 to 234

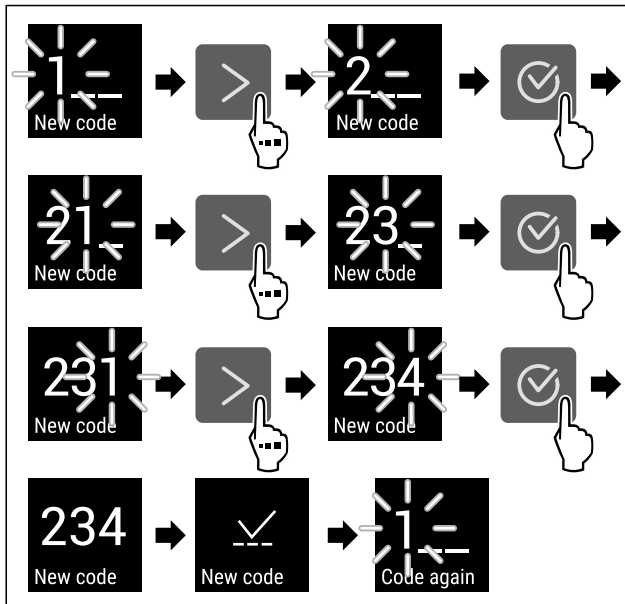

Fig. 61 Example illustration: Change display PIN from factory setting 1 1 1 to 2 3 4

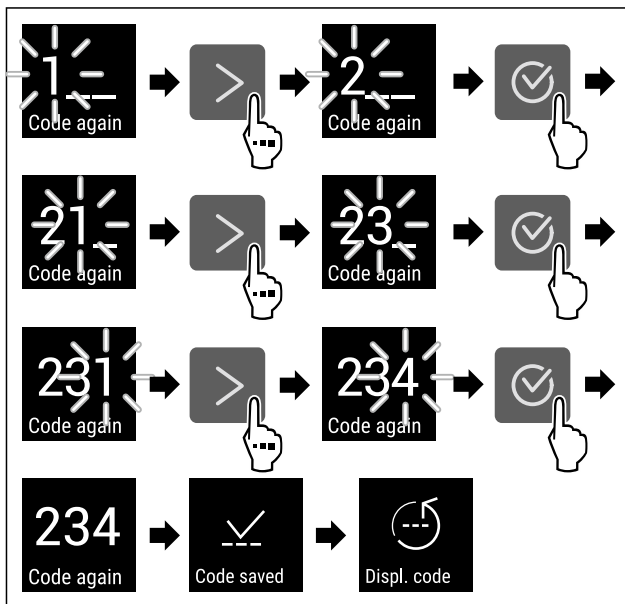

Fig. 61 Example illustration: Change display PIN from factory setting 1 1 1 to 2 3 4

- ▶ Carry out action steps according to the illustration.
- ▶ Display PIN is changed.

## 7.2.16 Language

This setting allows the display language to be set.

### Setting language

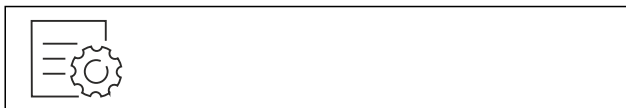

Fig. 62

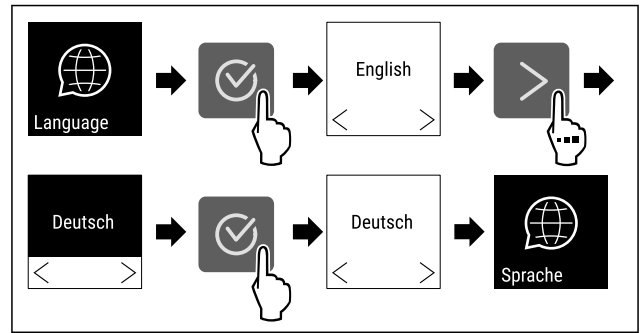

Fig. 63

- ▶ Carry out action steps according to the illustration.
- ▶ The selected language is set.

## 7.2.17 Appliance and software information

Use this function to indicate the model name, index, serial number and service number of your device. You will need the device information when you contact customer service. (see 10.4 Customer Service)

### Indicating the device information



Fig. 64

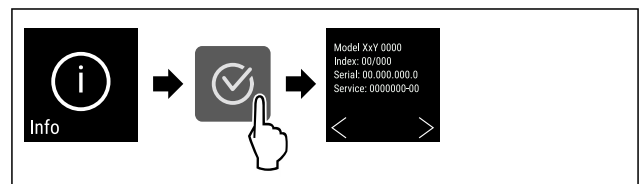

Fig. 65

- ▶ Carry out action steps according to the illustration.
- ▶ Display indicates device information.

### Displaying software information

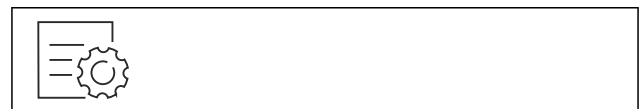

Fig. 66

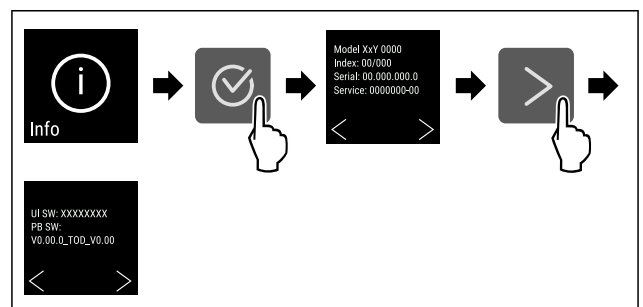

Fig. 67

- ▶ Carry out action steps according to the illustration.
- ▶ Display shows software information.

## 7.2.18 Reminder

Use this function to activate or deactivate the reminder to change the FreshAir activated carbon filter.

## Deactivating the reminder



Fig. 68

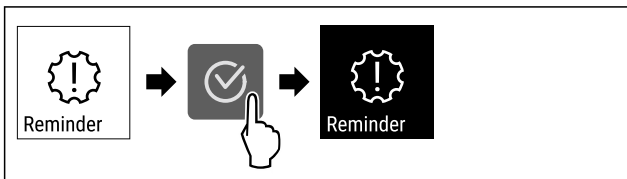

Fig. 69

- ▶ Carry out steps according to the illustration.
- ▶ Reminder is deactivated.

## Activating the reminder



Fig. 70

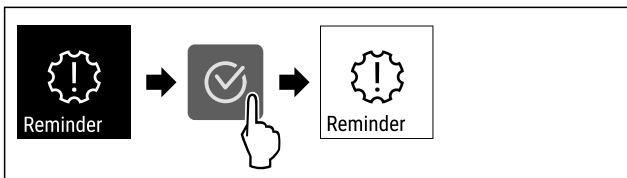

Fig. 71

- ▶ Carry out steps according to the illustration.
- ▶ Reminder is activated.

## 7.2.19 Demo mode



Demo mode is a special feature for dealers who want to demonstrate appliance features. If you activate demo mode, all refrigeration functions are deactivated.

If you switch on your appliance and a "D" appears on the status display, demo mode is already activated.

If you activate and then deactivate demo mode, the appliance will be reset to factory defaults. (see 7.2.20 Resetting to factory settings )

## Activating demo mode

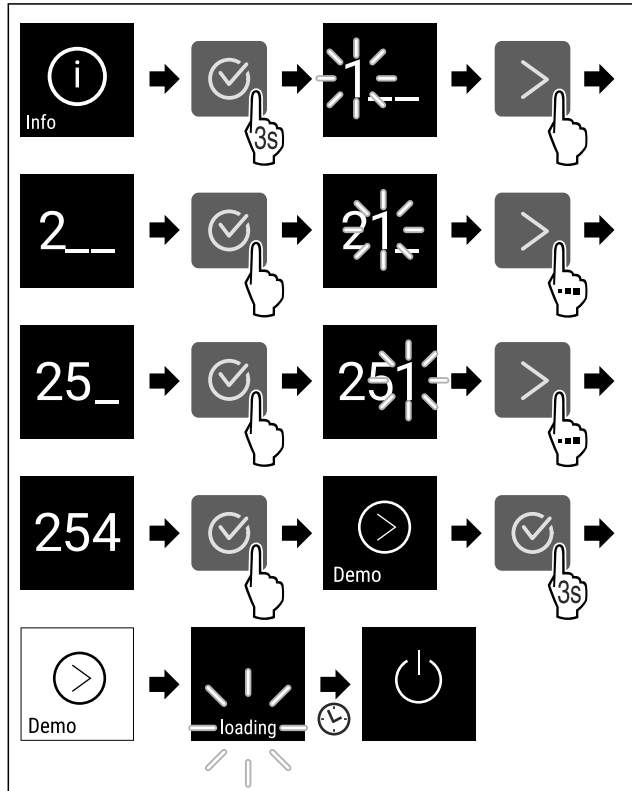

Fig. 72

- ▶ Carry out action steps according to the illustration.
- ▶ Demo mode is activated.
- ▶ Appliance is switched off.
- ▶ Switch on the appliance. (see 4.1 Switching on appliance (first use))
- ▶ "D" appears in the status display.

## Deactivating demo mode

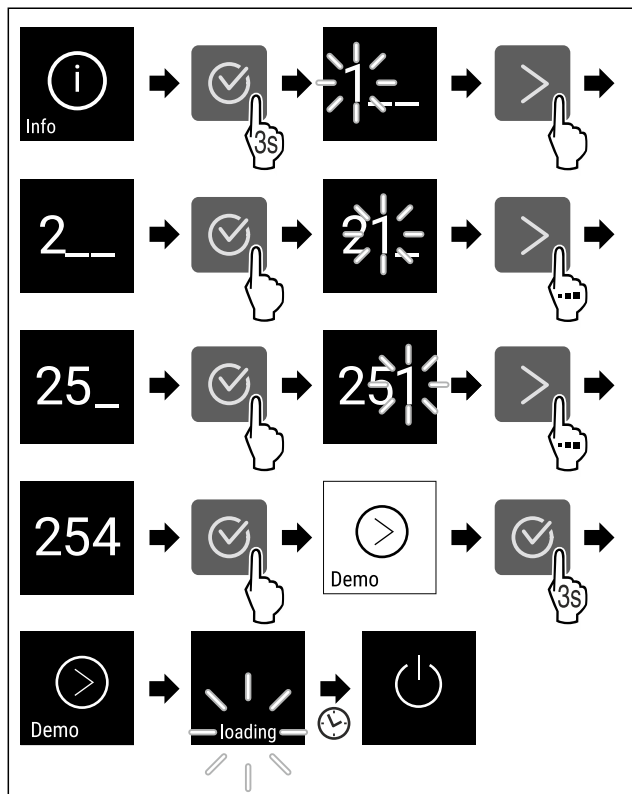

Fig. 73

- ▶ Carry out action steps according to the illustration.
- ▶ Demo mode is deactivated.

# Controls

- ▷ Appliance is switched off.
- ▶ Switch on the appliance. (see 4.1 Switching on appliance (first use))
- ▷ Appliance is reset to factory settings.



## 7.2.20 Resetting to factory settings

Use this function to reset all settings to factory defaults. All settings you have made so far are reset to their original settings.

### Performing a reset



Fig. 74

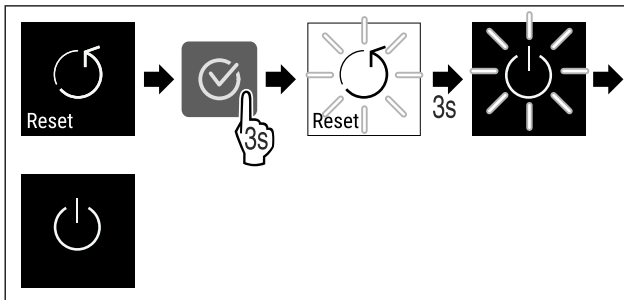

Fig. 75









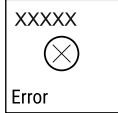

- ▶ Carry out action steps according to the illustration.
- ▷ Device is reset.
- ▷ Device is switched off.
- ▶ Restart the device. (see 4.1 Switching on appliance (first use))

## 7.3 Messages

### 7.3.1 Warnings



Warnings are issued by means of an audio signal and visually via a symbol on the display. The signal gets louder until the warning is acknowledged.

Message	Cause	Remedy
 Door open <b>Door open</b>	This message appears if the door is open for too long.	Close the door. Press the confirmation button. Alarm is ended. <b>Note</b> You can set how long it takes for this message to appear (see 7.2.10 Door alarm ).
 Temperature <b>Temperature alarm</b>	This message appears if the temperature does not match the set temperature. Reasons for the differences in temperature can be: - Warm items for refrigeration have been placed inside. - Too much warm room air flowed in when rearranging and removing refrigerated products.  The power was cut off for a prolonged period.	Press the confirmation button. Warmest temperature is displayed.  Press the confirmation button. The current temperature flashes and the display alternates with the temperature alarm symbol until the set temperature is reached.  Check the quality of the refrigerated goods. 

Message	Cause	Remedy
 <b>Error</b>	The appliance is defective, there is an appliance fault or a component of the appliance is faulty.	<p>Transfer refrigerated goods. Press the confirmation button. Error code is displayed.</p>   <p>Press the confirmation button. If present, another error code is indicated.</p> <p><b>or</b></p> <p>Status screen with flashing error symbol is displayed. Pressing the navigation buttons indicates error code(s) again. Note the error code(s) and contact customer service.</p>  
 <b>Power failure</b>	The message appears after an interruption in the power supply if the temperature is above the alarm limit when the power returns.	<p>Press the confirmation button. The warmest temperature is displayed.</p>  <p>Press the confirmation button. Alarm is cancelled and current temperature is indicated. Check the quality of the refrigerated goods.</p> 
 <b>WLAN error</b>	WLAN connection is interrupted.	<p>Check the connection. Press the confirmation button. Alarm is ended.</p>
 <b>WLAN WWW error</b>	The message appears if there is no Internet connection via WLAN.	<p>Check the connection. Press the confirmation button. Alarm is ended.</p>

### 7.3.2 Reminder

Reminders appear when you are being asked to do something. They are issued by means of an audio signal and visually via a symbol on the display. Acknowledge the message by pressing the confirmation button.

Message	Cause	Remedy
 <b>ReplaceFreshAir activated charcoal filter</b>	The message appears every 6 months.	<p>ReplaceFreshAir activated charcoal filter,</p>  <p>Reminder is closed.</p>

## 8 Features

### 8.1 Wooden grid

The appliances are equipped with a wooden grid for wine storage.

# Features

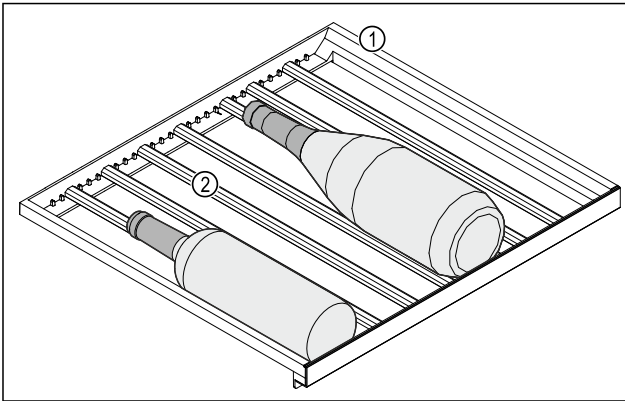

Fig. 76 Example illustration

(1) Wooden grid (2) Bar

The standard positions for the bars are indicated by notches. If you use these, you can store the maximum number of bottles. (see 5.2 Storage sketch)

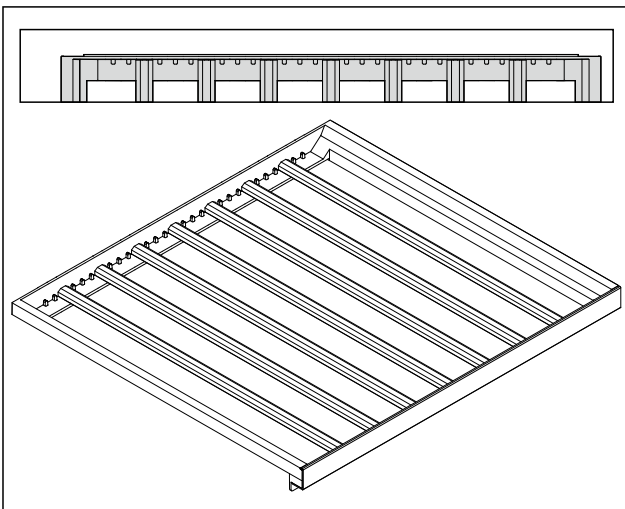

Fig. 77 Arrangement of the bars for maximum number of bottles.

## 8.1.1 Moving the bar

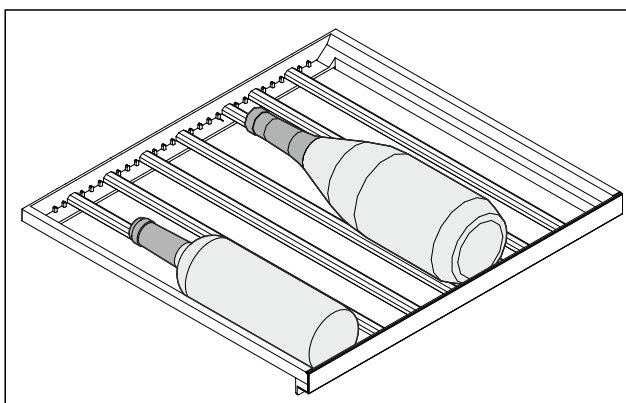

Fig. 78 Example illustration

You can remove the bars in the wooden rack to store larger or smaller bottles.

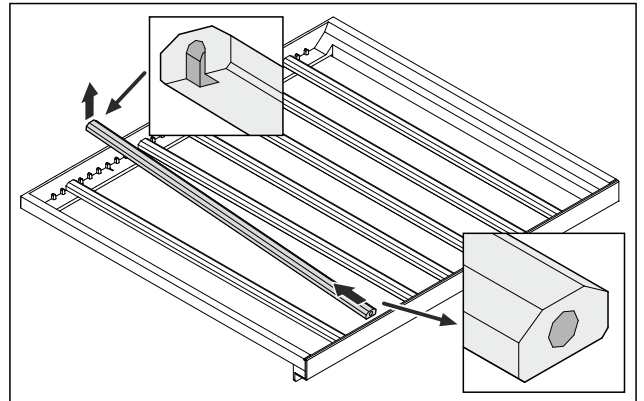

Fig. 79 Example illustration

► Lift and pull out the bar at the rear.

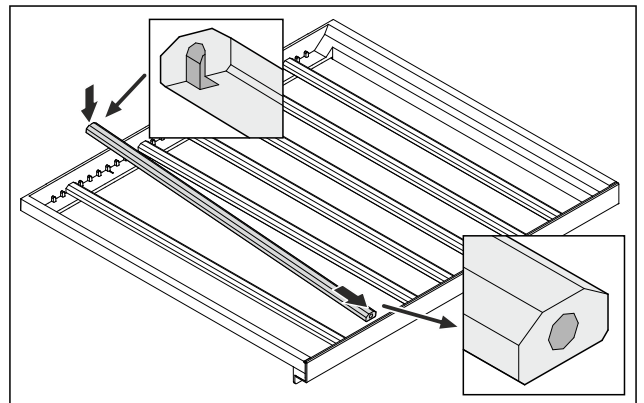

Fig. 80 Example illustration

► Insert the bar in the desired position.

## 8.1.2 Removing the wooden grid

You can remove the wooden grid for cleaning.

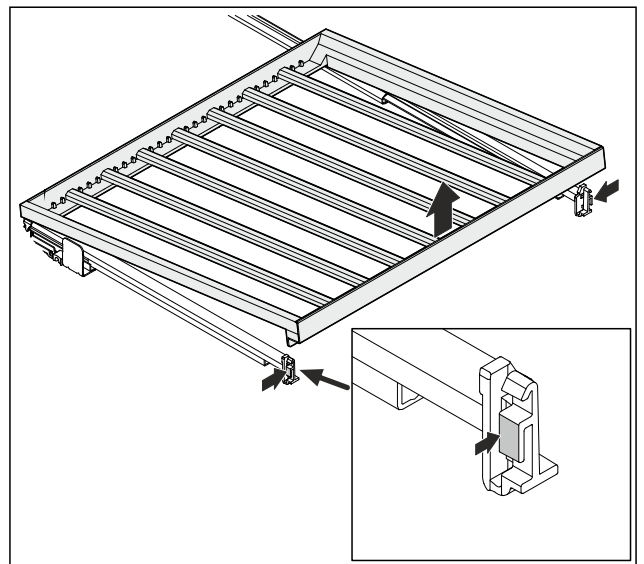

Fig. 81 Example illustration

► Press in slightly on both sides and lift up to remove.

## 8.1.3 Inserting the wooden grid

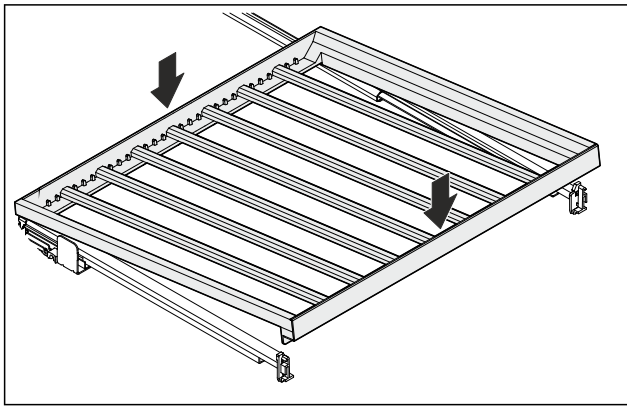

Fig. 82 Example illustration

- ▶ Place the wooden grid at the rear on the rails on the right and left.
- ▶ Lower the wooden grid at the front.
- ▶ The wooden grid locks in.
- ▶ Wooden grid is firmly seated in the rails.

## 8.2 Labels

Description labels as accessories can be purchased from your specialist dealer. You can use these to note the types of wine that are stored in the respective compartment.

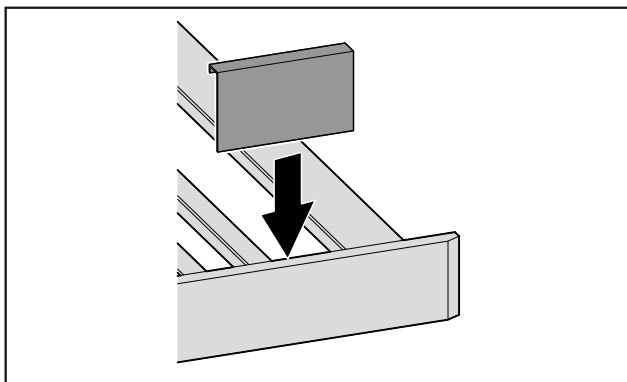

Fig. 83

- ▶ Attach the label from above.

## 9 Maintenance

### 9.1 FreshAir activated carbon filter

Wine is constantly developing according to its ambient conditions, so air quality is essential for preservation.

The FreshAir activated charcoal filter guarantees optimal air quality.

- Change the activated charcoal filter every 6 months.
- Dispose of the activated charcoal filter with regular household waste.

#### Note

FreshAir activated charcoal filters can be purchased from the Liebherr-Hausgeräte store at [home.liebherr.com/shop/de/deu/zubehor.html](http://home.liebherr.com/shop/de/deu/zubehor.html).\*

### 9.1.1 Replacing the FreshAir activated charcoal filter

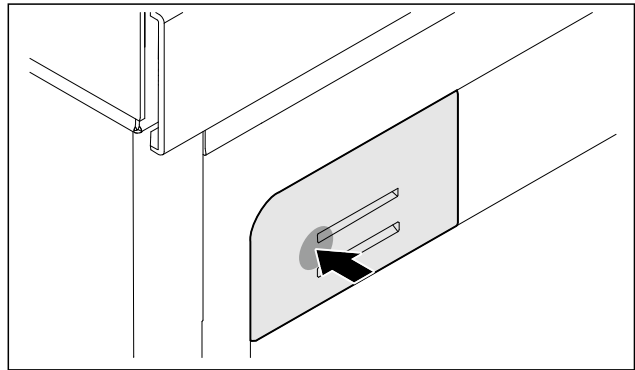

Fig. 84 Example illustration

- ▶ Press the filter holder in, release it again and pull it out.

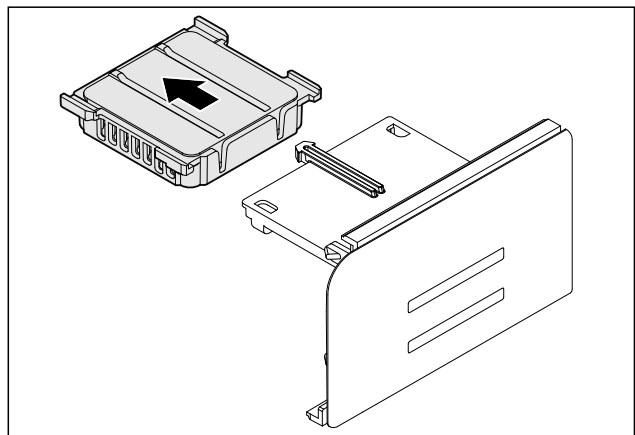

Fig. 85 Example illustration

- ▶ Remove the old filter from the holder.

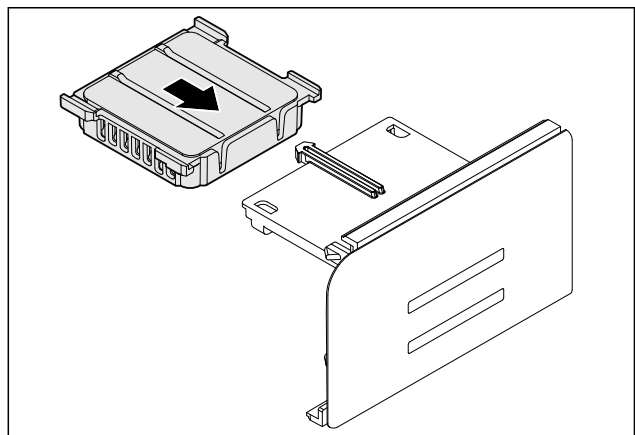

Fig. 86 Example illustration

- ▶ Snap the new filter into the holder.

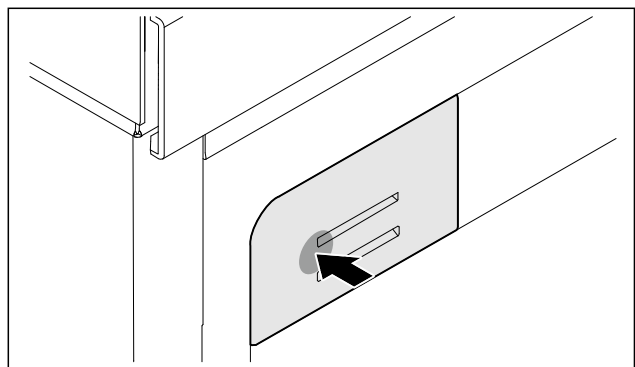

Fig. 87 Example illustration

- ▶ Press the filter holder in as far as it will go and release.
- ▶ FreshAir activated charcoal filter has been changed.

## 9.2 Cleaning the appliance

### 9.2.1 Ready



#### WARNING

Danger of electric shock!

- ▶ Remove the refrigerator connector or interrupt the power supply.



#### WARNING

Risk of fire

- ▶ Do not damage the refrigeration circuit.

- ▶ Empty the appliance.
- ▶ Remove mains connector.

### 9.2.2 Cleaning the interior

#### NOTICE

Improper cleaning!

Damage to the appliance.

- ▶ Only use soft cleaning cloths and ph-neutral all-purpose cleaners.
- ▶ Do not use abrasive sponges or steel wool which may cause scratches.
- ▶ Do not use any sharp or abrasive cleaning agents, nor any that contain sand, chloride or acid.

- ▶ Plastic surfaces: clean by hand with a soft clean cloth, lukewarm water and a little detergent.
- ▶ Metal surfaces: clean by hand with a soft clean cloth, lukewarm water and a little detergent.
- ▶ Drain hole: remove deposits using a thin item (for example a cotton bud).

### 9.2.3 Clean the components

#### NOTICE

Improper cleaning!

Damage to the appliance.

- ▶ Only use soft cleaning cloths and ph-neutral all-purpose cleaners.
- ▶ Do not use abrasive sponges or steel wool which may cause scratches.
- ▶ Do not use any sharp or abrasive cleaning agents, nor any that contain sand, chloride or acid.

#### Clean with a damp cloth:

- Retractable rails  
Please note: The grease in the tracks is used for lubrication and must not be removed!
- ▶ To disassemble components: see the relevant section.
- ▶ Clean the components.

### 9.2.4 After cleaning

- ▶ Wipe the appliance and the components dry.
- ▶ Connect and switch on the appliance.
- ▶ Repeat cleaning regularly.

## 10 Customer help

### 10.1 Technical specifications

Temperature range	
Cooling	5 °C to 20 °C

For appliances with a WiFi connection:\*

Frequency specification*	
Frequency band	2.4 GHz
Maximum radiated power	< 100 mW
Purpose of the wireless equipment	Integration in the local WiFi network for data communication

### 10.2 Operating noises

The appliance makes different noises when it is on.

- At **higher temperatures** the appliance uses less energy but works for longer. It is **quieter**.
- At **lower temperatures** the food is cooled faster. It is **louder**.

Examples:

- Functions on (see 7.2 Appliance functions)
- Fan running
- Food recently added
- High ambient temperature
- Door open for a while

Noise	Possible cause	Type of noise
Bubbling and splashing	Coolant flowing into the cooling circuit.	Normal operating noise
Hissing	Coolant sprays into the cooling circuit.	Normal operating noise
Humming	The appliance is cooling. The volume depends on the cooling output.	Normal operating noise
Suction noises	Soft-closing door is being opened and closed.	Normal operating noise
Humming and rustling	The fan is running.	Normal operating noise
Clicking	Components are switched on and off.	Normal switching noise
Rattling or humming	Valves or flaps are working.	Normal switching noise

Noise	Possible cause	Type of noise	Lifting
Vibration	Improper installation	Defective noise	Check the installation. Level the appliance.

Noise	Possible cause	Type of noise	Lifting
Rattling	Components, items inside the appliance	Defective noise	Secure components. Leave enough space between the items.

## 10.3 Technical fault

Your appliance is designed and built to ensure it works reliably and has a long service life. In the unlikely event that a fault occurs during operation, please check whether it is due to an operating error. If so, you will be charged for the callout and repair costs even if it falls within the warranty period.

You can fix the following faults yourself.

### 10.3.1 Appliance function

Defect	Cause	Remedy
<b>The appliance is not working.</b>	→ The appliance is not switched on.	▶ Switch the appliance on.
	→ The power plug is not properly plugged into the socket.	▶ Check the power plug.
	→ There is something wrong with the power outlet fuse.	▶ Check the fuse.
	→ Power cut	▶ Keep the appliance closed.
	→ The IEC socket is not plugged into the appliance correctly.	▶ Check the IEC socket.
<b>Temperature is not cold enough.</b>	→ The appliance door is not closed properly.	▶ Close the appliance door.
	→ Not enough ventilation.	▶ Keep ventilation grille clear, and clean it.
	→ The ambient temperature is too high.	▶ Problem solution: (see 2.4 Appliance range of use)
	→ The appliance was opened too many times or for too long.	▶ Wait to see if the required temperature corrects itself. If not, contact Customer Service. (see 10.4 Customer Service)
	→ The temperature is set incorrectly.	▶ Turn down the temperature and check after 24 hours.
	→ The appliance is too close to a heat source (oven, radiator, etc).	▶ Move the appliance or the heat source.
	→ The appliance was not correctly installed in the recess.	▶ Check if the appliance was installed correctly and that the door closes properly.
<b>The door seal is defective or needs to be replaced for another reason.</b>	→ You can replace the door seal, depending on your model. It can be replaced without the need for special tools.	▶ Contact Customer Service. (see 10.4 Customer Service)
<b>The door seal is defective or needs to be replaced for another reason.</b>	→ The door seal can be replaced. It can be replaced without the need for special tools.	▶ Contact Customer Service. (see 10.4 Customer Service)
<b>The appliance builds up too much ice or condensation.</b>	→ The door seal may have slipped out of its groove.	▶ Check that the door seal is well fitted in the groove.

### 10.3.2 Features

Defect	Cause	Remedy
<b>The internal light does not come on.</b>	→ The appliance is not switched on.	▶ Switch the appliance on.
	→ The door was open for longer than 15 minutes.	▶ Interior lighting switches off automatically after about 15 minutes when the door is open.

# Shutting down

Defect	Cause	Remedy
	→ The LED interior light is faulty or the lid is damaged.	▶ Contact Customer Service. (see 10.4 Customer Service)

## 10.4 Customer Service

First check whether you can rectify the fault yourself (see 10 Customer help) . If you cannot rectify the problem, contact Customer Service.

You can find the address in the enclosed brochure "Liebherr-Service" or at [home.liebherr.com/service](http://home.liebherr.com/service).\*

You can find the address at [home.liebherr.com/service](http://home.liebherr.com/service).\*



### WARNING

Unprofessional repair!\*  
Injuries.

- ▶ Have any repairs and action - not expressly specified - on the appliance and mains cable carried out by service personnel only. (see 9 Maintenance)
- ▶ A damaged mains cable may only be replaced by the manufacturer, the manufacturer's Customer Service or a similarly qualified person.
- ▶ In the case of appliances with an IEC connector, the change may be made by the customer.

### 10.4.1 Contacting Customer Service

Make sure that the following appliance information is available:

- Appliance name (model and index)
- Service no. (Service)
- Serial no. (S no.)
- ▶ Call up the appliance information via the display.
- or-
- ▶ Refer to the type plate for appliance information. (see 10.5 Model plate)
- ▶ Note down the appliance information.
- ▶ Notify customer service: Report errors and the appliance information.
- ▶ This will help us to provide you with a faster, more accurate service.
- ▶ Follow further instructions from Customer Service.

## 10.5 Model plate

The type plate is located on the bottom inside of the machine.

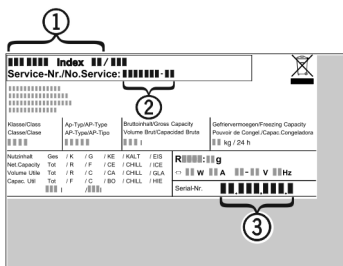

Fig. 88

- (1) Appliance description\*    (3) Serial no.\*  
(2) Service no.\*
- ▶ Note the data on the model plate.

## 11 Shutting down

- ▶ Empty the appliance.
- ▶ Switch off appliance. (see 7.2.2 Switching appliance on and off )
- ▶ Pull the mains plug out of the socket.
- ▶ Remove the IEC socket if required: Pull the IEC socket out of the appliance plug and move it to the left and right at the same time.
- ▶ Clean appliance. (see 9.2 Cleaning the appliance)
- ▶ Leave the door open, so that no unpleasant odours arise.

## 12 Disposal

Ensure that the following requirements are met:

- Meaning of the symbols on the appliance: are familiar.
- Notes on disposal are familiar.

### 12.1 Preparing the appliance for disposal

- ▶ Shutting your appliance down. (see 11 Shutting down)
- ▶ Remove lamps without damage.

### 12.2 Disposing of the appliance in an environmentally friendly manner



### WARNING

Leaking coolant and oil!  
Fire. The coolant contained in the appliance is eco-friendly, but also flammable. The oil contained in the appliance is flammable. Escaping coolant and oil can ignite if the concentration is high enough and in contact with an external heat source.

- ▶ Do not damage the pipelines of the coolant circuit and the compressor.
- ▶ Observe the notes on transporting the appliance.
- ▶ Remove the appliance without damaging it.
- ▶ Dispose of lamps in accordance with the aforementioned specifications.
- ▶ Dispose of appliance according to specifications.





[home.liebherr.com/fridge-manuals](https://home.liebherr.com/fridge-manuals)

**EN** wine cooling cabinet

Issue date: 20260403

**Part number index: 7083721-00**

Liebherr-Hausgeräte GmbH  
Memminger Straße 77-79  
88416 Ochsenhausen  
Deutschland