Masters for all tasks

T 38-6s T 33-7s T 38-7s T 42-7s
T 33-10s

LIEBHERR

Telescopic handlers



Generation
6

Lift height
6.0–10.0 m /
19'8"–32'10" ft in

Lift capacity
3.3–4.2 t

Performance

Infinitely variable travel drive
and maximum manoeuvrability

Efficiency

Low consumption and low costs

Reliability

Meeting daily requirements

Comfort

Ease of operation
and optimum overview

Maintainability

Simple maintenance and repairs



T 38-6s

Lift height
6.0m
Lift capacity
3.8t
Engine power
105 kW / 143 HP
Hydrostatic travel drive
with electronic control

T 33-7s

Lift height
7.0m
Lift capacity
3.3t
Engine power
105 kW / 143 HP
Hydrostatic travel drive
with electronic control



T 38-7s

Lift height

7.0m

Lift capacity

3.8t

Engine power

105 kW / 143 HP

Hydrostatic travel drive

with electronic control

T 42-7s

Lift height

7.0m

Lift capacity

4.2t

Engine power

105 kW / 143 HP

Hydrostatic travel drive

with electronic control

T 33-10s

Lift height

10.0m

Lift capacity

3.3t

Engine power

105 kW / 143 HP

Hydrostatic travel drive

with electronic control

Performance



Infinitely variable travel drive and maximum manoeuvrability

The tried-and-tested hydrostatic travel drive with infinitely variable acceleration without shifting gear and good manoeuvrability guarantees quick work processes even in limited spaces. The construction machine can be used universally and is solid from the ground up. It is designed for maximum performance in various applications. High load capacities, intuitive operation and high performance components allow the driver to complete his work quickly and reliably.

High load capacities

Excellent weight distribution

The newly designed frame and balanced wheelbase ensure a low centre of gravity. As a result, Liebherr's telescopic handler performs with impressive stability when loading and stacking.

Optimised boom design

The robust telescopic boom is mounted low on the frame. Strong slide bearings allow for perfect guidance even with heavy loads. The hoist and telescopic cylinders feature end position damping to protect the driver and the machine when moving heavy loads.

Maximum performance

The Liebherr telescopic handler generation 6 scores with increased lifting capacities and even greater performance thanks to the electronic pilot control of the working hydraulics.



Auto Power for fast charging cycles

- The optional Auto Power function automatically adjusts the engine speed in order to be able to call up the required power from the working hydraulics – without varying the driving speed

Intelligent interaction

Powerful working hydraulics

The S telehandlers have a load sensing pump with LIFD control block, which enables faster work cycles and simultaneous movements. EcoMotion lowers the telescopic boom without engine assistance, saving fuel and making operation easier. MultiMotion offers a fully automatic, proportional retraction movement of the telescopic boom when lowering. This increases driver comfort and efficiency.

Modern diesel engine

The high-torque power pack with Common-Rail injection system ensures a high level of reliability and excellent power delivery in the most demanding situations.

Liebherr travel drive

The infinitely variable hydrostatic travel drive and the many years of Liebherr know-how guarantee excellent driving performance in every operating situation.



Superior drive system

- The stepless speed control allows the handler to be driven without shifting gear and totally free from jolts
- Practically no brake wear
- Low fuel consumption
- Precise, rapid and safe manoeuvring

Compact and optimised cooling

Simple selection of steering modes

All steering modes can be selected comfortably via an operating lever: Front wheel steering, all-wheel steering and crab steering. In addition, the fourth steering mode allows the rear axle to be locked in any position, whereby front wheel steering is engaged on full wheel lock. An LED keeps the driver updated on the neutral position of the wheels.

Cooling guaranteed

The sophisticated air cooling, in combination with the suction fan and large size cooling unit, keeps the machine at an ideal operating temperature even on hot days. A reversible fan removes impurities from the air intake surfaces of any dirt or contamination and thereby always ensure optimum cooling.



Compact and manoeuvrable

- The continual limited-slip differential of 45% allows work on even the most difficult terrain
- The optimised kinematics ensure maximum manoeuvrability when using the fork and bucket functions

Efficiency



Low consumption and low costs

The Liebherr 's' telescopic handlers are all-rounders that will complement your existing machine fleet and further increase its efficiency. Many different optional attachments allow universal use and increased utilisation of the machines. Top performance, low fuel consumption and minimum maintenance guarantee economy throughout the service life of the machine.

An all-rounder

An impressive variety of attachments

The wide range of attachments make the Liebherr telescopic handler an all-rounder. Whether a simple fork, one of the many buckets or a brush – every task is mastered.

Versatile and flexible

Numerous options, such as guard grilles, manual steering kit and an extension for working circuit-3, allow the configuration of the machine to be perfectly matched to the most varied of applications. You can expect a machine that is tailored to your specific customer and application requirements.

Universal use

The swivel mounted rear axle allows reliable and effortless driving on any terrain. With the 10 m machine (T 33-10), level compensation (up to 8°) ensures a firm footing at all times.

Low operating costs

Low fuel consumption

The Liebherr drive concept is designed for high performance. The intelligent electronic controller of the hydrostatic travel drive guarantees maximum tractive force in every work situation. The interaction of the tried-and-tested drive components with the diesel engine and the hydraulic system reduces the fuel consumption at maximum performance.

Intelligent cooling

The fan speed is electronically regulated and hydrostatically controlled depending on the temperature of the surroundings, hydraulic oil and engine. The cooler pack is easily accessible and easy to clean.

Easy maintenance

Maximum accessibility to all maintenance points. Long maintenance intervals keep expenditure low and reduce daily work to a minimum. Options such as the central lubrication system contribute to the further reduction of repair times and increased availability of the machine.



Flexible and versatile

If the telescopic handler is fitted with a hydraulic quick-release coupling, the attachments can be changed at the touch of a button. That saves time and money and increases productivity.



Easy maintenance

Due to the transverse mounting position of the stage V engine, all control and maintenance points are easily accessible in the engine compartment, allowing daily maintenance to be performed in a simple and time saving manner.



After-treatment exhaust gas

The exhaust gas is cleaned via a diesel oxidation catalytic converter, an additional diesel particulate filter combined with an SCR catalytic converter. This system complies with the exhaust gas emission limits for stage V.

Reliability



Meeting daily requirements

Robust and reliable: as characterised by Liebherr 's' telescopic handlers. Advanced technology with high-quality materials and build quality guarantee maximum availability. A high level of utilisation and value is guaranteed in the long term.

Quality right down to the last detail

Tried-and-tested components

Only components that have been tested under the most rigorous conditions are used in Liebherr telescopic handlers.

Robust and well-thought-out design

With the robust quick coupler – suitable for Scorpion work attachments – all tools can be perfectly and reliably fitted. Attachments with a hydraulic function can be conveniently operated with a joystick via the double-acting hydraulic circuit-3 installed as standard. A double-acting additional hydraulic circuit with a leakage oil line and a socket can also be installed as an option.

Pressure release for hydraulic circuit-3

The couplings do not require pressure to be applied to enable the attachments to be changed quickly and easily. Pressure release is available as an option and prevents unnecessary loss of oil or broken seals in the couplings.

Coherent safety control

Intelligent overload warning system

A warning system constantly informs the driver of the load status of the unit. Even before the unit can tip forwards, hydraulic lifting movements are slowed down right until standstill (at this point a sufficient margin of safety is still retained). Beyond this point, only movements of the attachment, which reduce the risk of tipping, can be made.

To enable efficient filling of the bucket, stockpiling mode can be selected. In this setting, boom movements are not limited even if overload is detected, as long as the machine keeps moving forward.

In addition, the driver can temporarily de-activate the overload warning system.

Fuel tank

Long working and application times are guaranteed with a holding capacity of 150 l / 33 Imp.gal. The tank is positioned underneath the cab which provides optimum protection from damage.



Cable protection

- The tried-and-tested protective braiding prevents wear and mechanical damage to the electrical system
- In addition, condensation is inhibited to eliminate any risk of short circuiting



Reliable safety systems

- A wide variety of standard and optional safety devices enable safe working in every situation. This includes:
- Halogen or LED lighting¹
 - End position damping²
 - Emergency lowering¹
 - Reversing and side movement camera¹
 - Inclination display on telescope¹

¹option, ²standard



Overload warning system

For stacking, loading or lifting, the right setting can be selected according to requirements, ensuring safety and high performance operation in compliance with EN 15000 – regardless of the situation.

Comfort



Ease of operation and optimum overview

The cab of the 's' telescopic handler from Liebherr is an ideal workplace. It provides an excellent all-around view, has a spacious interior, provides a safe working environment, and its ergonomic controls are ideal for relaxed and productive operation.

Unobstructed view

Low pivot point

During development, ensuring good operator visibility was of paramount importance. For this reason, the pivot point of the arm has been placed as low as possible so that the driver has a clear view both to the rear and to the right.

Safety coupled with large windows

The soundproof ROPS / FOPS cab ensures a safe and pleasant working environment. Thanks to the extensive glazing and the deep windscreen, the driver always has a safe view to the attachment and the surroundings.

Safely home

The Coming Home function enables the driver to get out safely, especially in the dark, and reduces the risk of accidents. The function increases both safety and the efficiency of the work process.



Seating comfort and ergonomics

- The multi-adjustable, sprung driver's seat with backrest extension adapts individually to the driver
- The swivel steering column comes as standard and is also height-adjustable as an option
- The joystick integrated in the driver's seat allows fatigue-free and precise work

Effortless operation

One-hand operation

All the functions of the boom are conveniently controlled with the right hand using a joystick. Even forward and reverse direction can be selected on the joystick. This means the driver can always keep one hand on the steering wheel and the other on the joystick. This easy and ergonomic operation provides comfort and safety for long working days.

Combined inch-brake pedal

The speed is reduced by pressing the inch-brake pedal. Pressing further down activates the brake function. The operator controls the engine and working speeds with his right foot using the accelerator pedal.



Optimum visibility in all directions

- The innovative protective design of the roof window provides a perfect view of the load while also protecting the driver
- The displays are optimally located at the front right in the driver's field of vision

Safe position

Auto-Hillassist

The parking brake is automatically electronically activated when the machine stops to prevent it from rolling away. A seat contact switch automatically detects that the parking brake must remain activated when the driver exits the telescopic handler. The parking brake is released by moving to the neutral position using the travel direction switch. This saves the driver reaching into the cab unnecessarily. The parking brake can also be engaged using a switch next to the joystick on the right.

Displays and operation

The 3.5" large colour display used in combination with the fully electronic control makes operation easier. The colour display is also available in a 7" version.



Fine control of movement hydraulics

- Using two switches on the joystick, the drive speed can be split into three ranges (snail, turtle and hare pace)
- The engine and maximum drive speed can be comfortably set using the optionally available manual control pack

Maintainability



Simple maintenance and repairs

At Liebherr, superior service is more than a promise, it is a guarantee to every customer. Several production facilities and an extensive service network for construction equipment means close proximity, efficient structures, and fast service reaction times.

High-performance service

Solid basis

When you buy a Liebherr telescopic handler, you enter a solid, long-term partnership. Our production facilities and service partners guarantee it.

Extensive service network

An extensive worldwide service network and service stations with the latest equipment guarantee rapid support whenever required. 98% of all spare parts are kept in stock and can be dispatched from our modern distribution centre at very short notice.

Comfortable maintenance

In planning the new telescopic handlers, great emphasis was placed on ease of maintenance. As a result, all service points are readily accessible for daily inspection. Refuelling can be comfortably carried out at ground level.

Knowledge ensures value

Experience and training

Comprehensive know-how ensures first-class and effective service and maintenance. This contributes significantly to availability and cost effectiveness. Liebherr customer service technicians undertake extensive training and continual education at the production plants. Their comprehensive knowledge provides you with fast, reliable service.

Continuous dialogue with users

We utilise the expert knowledge and practical experience of our customers to consistently optimise our machines and services – real solutions for real situations.

Competent advice and service

Experienced specialists provide decision making support for your specific requirements: application oriented sales support, service agreements, value priced repair alternatives, original parts management, preventative service measures, as well as remote diagnosis for troubleshooting and correction.



Highest quality service

Workshops with state-of-the-art equipment and customer-oriented service call planning guarantee fast supply of spare parts and provide the basis for high machine availability and cost effectiveness.



Time and cost savings

- All service points are centrally located and readily accessible. Daily inspection of the machine is organised in a simple and time saving manner due to the wideopening engine hood
- Long service intervals save costs and minimise downtime



Dependable lubrications

Various lubrications methods are available in order to reduce maintenance of the machine to a minimum:

- Lubrication through outward extended lubrication points – easy lube
- Lubrication through three central points – centralised lube
- Lubrication through automatic central lube unit – auto lube

Technical data



Engine

Deutz Diesel engine	Liebherr Deutz TCD3.6 L4 Emissions regulations according to ECE-R.96 Stage IIIa, 2016/1628 Stage V, EPA/CARB Tier 4 Final
Rated power ISO 14396	105 kW / 143 HP at 2,300 rpm
Max. torque	550 Nm at 1,600 rpm
Displacement	3.6 l / 220 in ³
Design	4-cylinder in-line engine, water-cooled, turbocharger, air-to-air aftercooler
Injection system	Electronic common-rail injection
Air filter	Dry air filter with safety cartridge and dust ejector
Cooling system	Hydrostatically powered, thermostatically controlled fan
Operating voltage	12 V
Batteries	12 V / 180 Ah
Alternator	14 V / 150 A
Starter	3.2 kW / 4 HP



Travel drive

Design	Stepless hydrostatic travel drive with axial piston variable displacement pump and Liebherr hydro motor in a closed circuit, forward and reverse travel achieved by changing the flow direction of the variable displacement pump
Filter system	Pressure filter for closed circuit
Control	Via electronic accelerator and combined brake-inch pedal, constant adjustment of tractive force at maximum diesel engine speed. Changes of direction can be selected using multifunction joystick
Travel speed	Stepless variable 0 - 40 km/h / 24.7 mph 0 - 30 km/h / 18.6 mph (option) 0 - 20 km/h / 12.4 mph (option)



Sound levels

Operator sound exposure ISO 6396:1992	
L_{pA} (at the cab)	69 dB (A)
Exterior sound pressure 2000/14/EC	
L_{WA} (to the environment)	107 dB(A)



Brakes

Service brake	Deceleration effective on all four wheels by hydrostatic travel drive, hydrostatically operated wet multiple-disc brakes in the front axle (internal)
Parking brake	Internal hydraulic spring-loaded brakes inside the front axle



Operator's cab

Cab	Resiliently mounted, closed cab with positive pressure ventilation. Integrated ROPS/FOPS structure, tinted safety glass for the single front and roof panel, windscreen wiper and washing system for front and rear windscreen, steering column inclination adjustable using foot pedal. The upper part of the cabin door can be opened 180° and locked at this position
Operator's seat	Cushioned driver's seat, adjustable, with safety belt. Adjustable to suit weight of the driver
Ventilation	Multi-speed fan with fresh-air intake and filtering, 7 adjustable air vents, 2 air vents on front windscreen, hinged rear window
Heating	Warm-water heating
Vibration emission	
Hand / arm vibrations	< 2.5 m/s ² , according with ISO 5349-1:2001
Whole-body vibrations	0.19 - 0.71 m/s ² , complies with technical report ISO/TR 25398:2006
Measuring inaccuracy	According with standard EN 12096:1997



Tyres

Standard tyre equipment	Mitas MPT-04 400/70-24
Design	Tubeless tyres on one-piece rims
Special tyre equipment	As specified by manufacturer



Steering

Design	Hydraulic steering of front and rear axles
Types of steering	Steering modes 3 + 1 electronically switchable: <ul style="list-style-type: none"> - Front wheel steering (for road driving) - All-wheel steering - Crab steer - Front wheel steering with adjusted rear axle

Axles

Drive	All-wheel drive
Front axles	Steering knuckle control, rigid mounting, at 10 m Model level adjustment with 8° oscillation
Rear axles	Steering knuckle control, fitted to swing with a 11° oscillation
Differential	Automatic 45% limited-slip differential in the front axle
Transmission	Planetary gear in the wheel hubs

Refill capacities

Fuel tank	150l / 33 Imp.gal
Diesel Exhaust Fluid (DEF) tank	10l / 2.2 Imp.gal
Cooling system	18l / 4 Imp.gal
Engine oil (incl. filter change)	8.5l / 1.9 Imp.gal
Hydraulic tank	96l / 28.6 Imp.gal
Total hydraulics 6 m and 7 m models	140l / 30.8 Imp.gal
Total hydraulic 10 m model	150l / 33 Imp.gal
Differential gears front	8.5l / 1.9 Imp.gal
Differential gears rear	8.5l / 1.9 Imp.gal
Front axle hub, each	1.0l / 0.2 Imp.gal
Rear axle hub, each	1.0l / 0.2 Imp.gal

Performance data

		T 38-6s	T 33-7s	T 38-7s	T 42-7s	T 33-10s
Operating weight with standard forks, with a full fuel tank, minimum configuration, Michelin XMCL (460/70-24) tyres and without operator	kg	7,420	7,500	7,540	7,750	8,100
	lb	16,358	16,535	16,623	17,086	17,857
Max. lift capacity	kg	3,800	3,300	3,800	4,200	3,300
	lb	8,378	7,275	8,378	9,259	7,275
Max. lift height	mm	6,225	6,925	6,925	6,925	9,747
	ft in	22'5"	22'9"	22'9"	22'9"	32'
Max. forward reach to front carriage	mm	3,204	3,996	3,996	4,001	7,176
	ft in	10'6"	13'1"	13'1"	13'2"	23'7"

Hydraulics

Hydraulic system	Load sensing-pump
Pump flow max.	160l/min. / 35.20 Imp.gpm at 1,900 rpm (Diesel engine)
Max. operating pressure	250 bar ¹⁾ / 3,480 psi ¹⁾ or 270 bar ²⁾ / 3,915 psi ²⁾
Filter system	Return oil filter and intake filter
Control	Multifunction joystick
Controlled functions	Lift, lower, tipping inwards, tipping outwards, retract, extend, close, open, forwards, backwards „subdivision of 3 speed ranges“
Control valves	Load-control valves on lifting, tilt and telescopic cylinders
End position damping	Lift, lower, tipping inwards
Max. flow rate at front working circuit	110l/min. / 24.2 Imp.gpm
EcoMotion	With EcoMotion the telescope boom is lowered without help from the Diesel engine

¹⁾ T 33-7s

²⁾ T 38-6s, T 38-7s, T 42-7s and T 33-10s

Cycle times (without load, without end position damping)

		T 38-6s	T 33-7s	T 38-7s	T 42-7s	T 33-10s
Lifting	sec	6.8	6.8	6.8	7.0	6.5
Lowering	sec	5.0	5.0	5.0	6.2	5.3
Extend	sec	4.8	5.7	5.7	6.3	11.6
Retract	sec	3.5	4.2	4.2	5.1	8.2
Tilting inwards, full angle	sec	3.7	3.7	3.7	3.7	3.3
Tilting outwards, full angle	sec	3.3	3.3	3.3	3.3	3.0

Dimensions

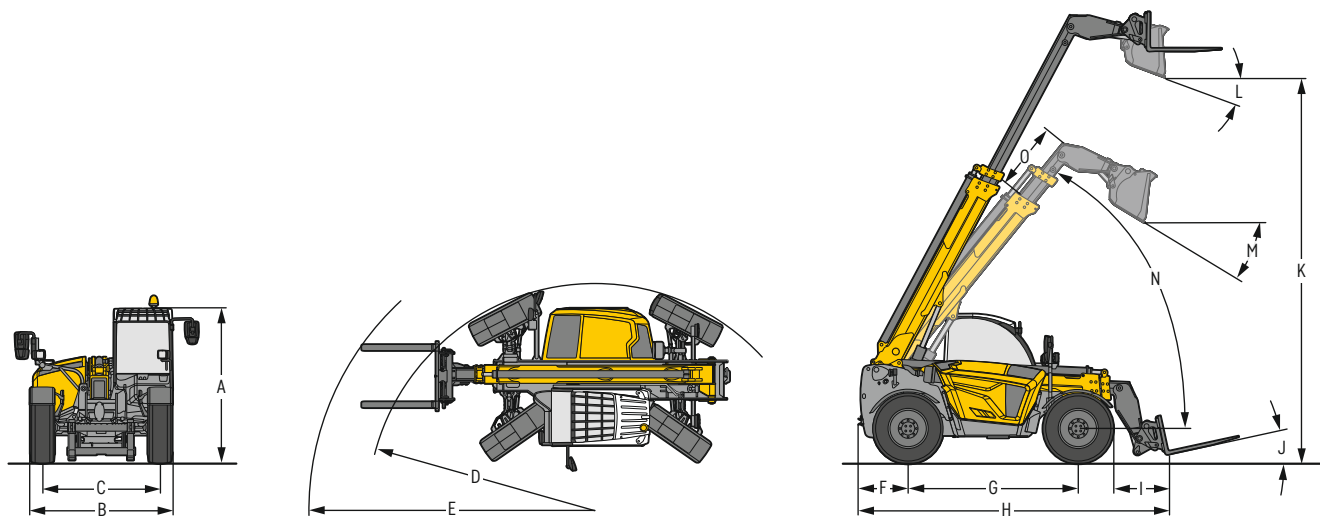

Dimensions (all specifications with standard tyres, standard fork or standard bucket (0.9 m³ / 1.18 yd³))

		T 38-6s	T 33-7s	T 38-7s	T 42-7s
A Height over cab	mm	2,474	2,474	2,474	2,474
	ft in	8'1"	8'1"	8'1"	8'1"
B Overall width over standard tyres	mm	2,327	2,327	2,327	2,327
	ft in	7'8"	7'8"	7'8"	7'8"
C Track gauge	mm	1,920	1,920	1,920	1,920
	ft in	6'4"	6'4"	6'4"	6'4"
D Outside turning radius over tyres	mm	4,065	3,950	4,070	4,050
	ft in	13'4"	13'	13'4"	13'3"
E Outside turning radius over forks	mm	4,800	4,850	4,750	4,920
	ft in	15'9"	15'11"	15'7"	16'2"
F Rear overhang	mm	784	784	784	784
	ft in	2'7"	2'7"	2'7"	2'7"
G Wheels base	mm	2,850	2,850	2,850	2,850
	ft in	9'4"	9'4"	9'4"	9'4"
H Overall length to front carriage	mm	4,710	4,905	4,910	4,910
	ft in	15'5"	16'1"	16'1"	16'1"
I Reach at max. lifting height with extended telescope and max. tip out angle	mm	-	449	449	449
	ft in	-	1'6"	1'6"	1'6"
J Max. tip out angle, lower pallet fork	mm	12.9°	12.9°	12.9°	12.9°
	ft in	-	-	-	-
K Dumping height at max. lifting angle of 61.9° with extended telescope and max. tip out angle	mm	5,536	6,235	6,235	6,235
	ft in	18'2"	20'5"	20'5"	20'5"
L Max. tip out angle, standard bucket at max. lifting angle	mm	44.4°	44.4°	44.4°	44.4°
	ft in	-	-	-	-
M Max. tip out angle, standard bucket at 4 m loading edge Ground clearance (middle of vehicle)	mm	58.1°	58.1°	58.1°	58.1°
	ft in	405	405	405	405
Max. rotation angle, machine mounting	mm	1'4"	1'4"	1'4"	1'4"
	ft in	150°	150°	150°	150°

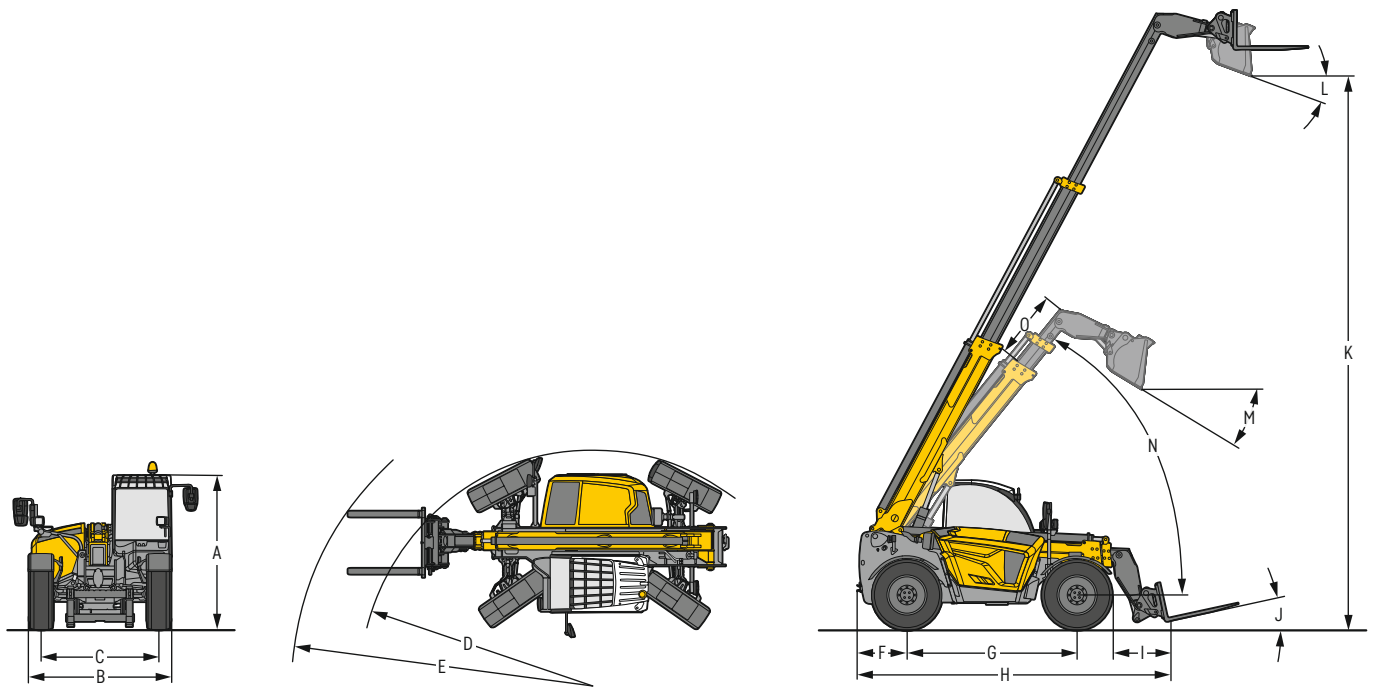

Dimensions (all specifications with standard tyres, standard fork or standard bucket (0.9 m³ / 1.18 yd³))

		T 33-10s
A Height over cab	mm	2,474
	ft in	8'1"
B Overall width over standard tyres	mm	2,327
	ft in	7'8"
C Track gauge	mm	1,920
	ft in	6'4"
D Outside turning radius over tyres	mm	4,100
	ft in	13'5"
E Outside turning radius over forks	mm	5,200
	ft in	17'1"
F Rear overhang	mm	784
	ft in	2'7"
G Wheels base	mm	2,850
	ft in	9'4"
H Overall length to front carriage	mm	5,104
	ft in	16'9"
I Reach at max. lifting height with extended telescope and max. tip out angle	mm	2,339
	ft in	7'8"
J Max. tip out angle, lower pallet fork		12°
K Dumping height at max. lifting angle of 61.9° with extended telescope and max. tip out angle	mm	9,258
	ft in	30'4"
L Max. tip out angle, standard bucket at max. lifting angle		44.4°
M Max. tip out angle, standard bucket at 4m loading edge		31.2°
	Ground clearance (middle of vehicle)	mm
	ft in	1'4"
Max. rotation angle, machine mounting		126°

Load charts (acc. to EN 1459, appendix B)

All specifications with standard quick coupler, load centre 500 mm / 1'8" ft in, standard tyres and standard fork

T 38-6s

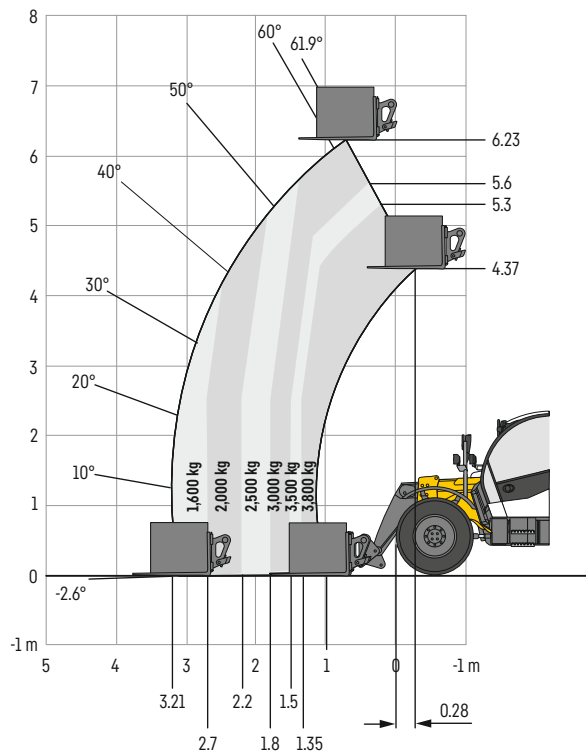

T 33-7s

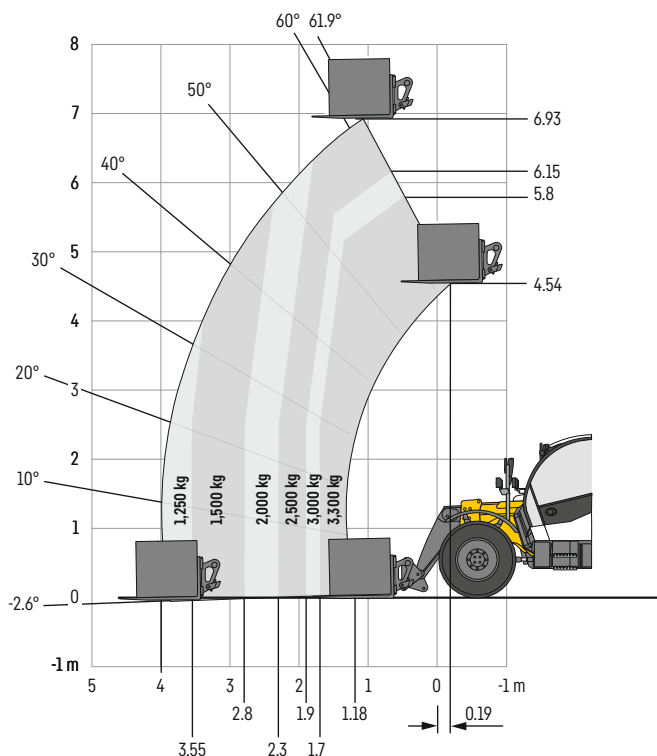

T 38-7s

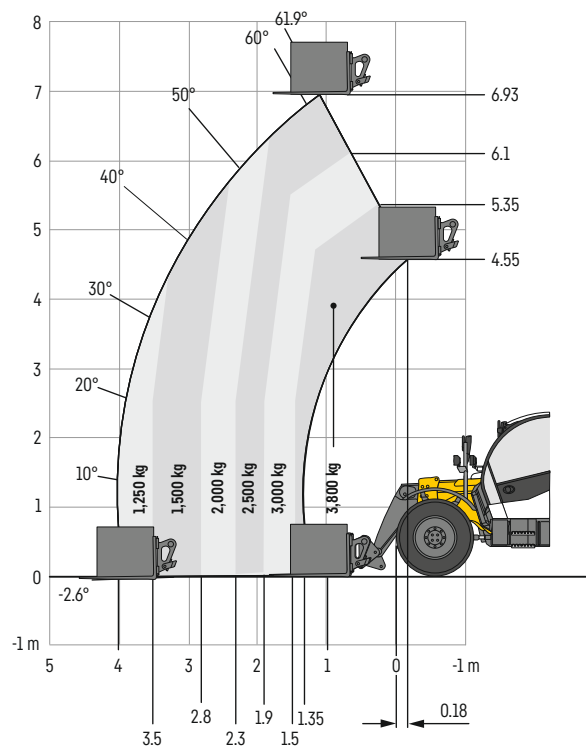

T 42-7s

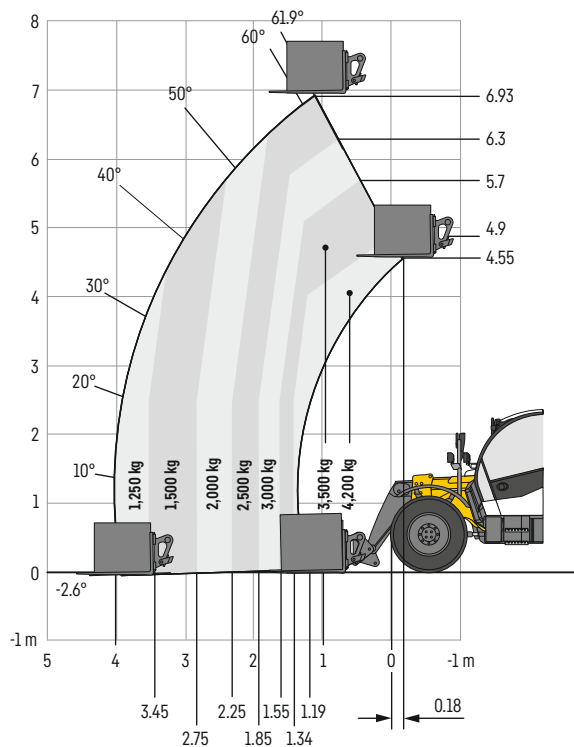

T 33-10s

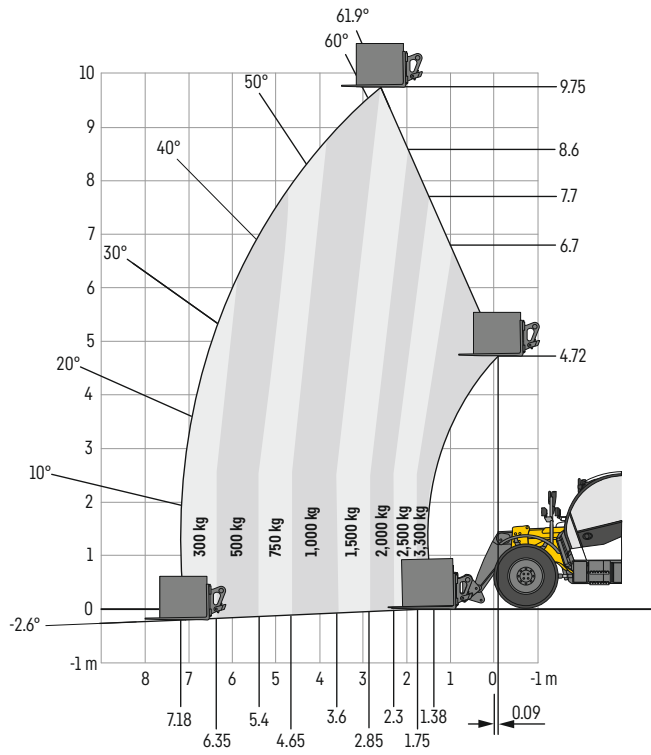

Equipment



Base machine

2 part telescopic boom (with 6 m and 7 m models)	•
3 part telescopic boom (with 10 m models)	•
All-round engine mount protection	+
Anti-vibration dampers - Comfort Drive	+
Auto Hill Assist	•
Custom paint	+
Front towing hitch	+
Fuel preheater	+
Hydraulic fluid level monitor	+
Illuminated licence plate holder	+
Inch brake pedal	•
Jib guidance on base frame	+
Level adjustment front axle (for 10 m models)	•
Liebherr Connect - data transmission system	+
Lubrication ready kit for automatic central lubrication system	+
Lubrication through automatic central lube unit - Auto-Lube	+
Lubrication through outward extended lubrication points - Easy-Lube	+
Lubrication through three central points - Centralised-Lube	+
Main frame and underbody safety guard	+
Main frame protective cover	+
Protective wax for aggressive media (protective wax on telescopic head and on front panel)	+
Protective wax for sea shipment	+
Rear 7 pole socket	+
Rear axle with 11° swing	•
Rear towing hitch	+
Rear view mirror directed at towing hitch	+
Road traffic certification Germany	+
Self-locking differential 45% on front axle	•
Steering modes 3 - 1, electronically preselectable	•
Tool kit	+
Tool kit with tool box	+
Towing hitch with automatic locking	+



Operating hydraulics

Bucket return	+
Constant flow for operating hydraulics on telescopic head	+
Constant flow rear hydraulics	+
Dirt guard on telescopic boom	+
EcoMotion	•
Electrical ready kit on telescopic head	+
Extension for operating circuit 3 (hydraulic & electric)	+
Front attachment unit switchable 4 pole socket	+
High flow on telescopic head (by parallel switching of op. circ. 3)	+
Hydraulic operating circuit-3 on telescopic head	•
Hydraulic pump, feed rate 160 l/min	•
Operating hydraulics deactivation (for travelling on roads)	•
Overflow oil line	+
Preheater for hydraulic oil using external 230 V power supply	+
Pressure relief for operating hydraulics on the telescopic head	+
Rear hydraulics ready kit	•
Rear hydraulics, single- and double-acting	+
Single acting rear hydraulics	+
Tipping cylinder lock	+



Operator's cabin

12 V socket	•
2 part driver's door (upper part can open 180°)	•
Air sprung driver's seat with heating and backrest extension	+
Air-conditioning unit	+
Armrest mounted on the seat	+
Clothes hook	•
Colour 3.5" display	•
Colour 7" display	+
Front cabin work spotlight (LED or LED+)	+
Front windscreen wiper and washer system with intermittent switch (incl. roof area)	•
Heating	•
Interior lighting	•
Internal rear view mirror	+
Liebherr Silent Design (anti-noise package to reduce the noise level)	+
Low frequency sprung driver's seat including seat heating and backrest extension	+
Mechanical driver's seat with fabric cover and backrest extension	•
Mobile phone holder	+
Multi-functional holder	+
Multifunction joystick mounted on the seat	•
Radio ready kit	+
Radio with USB connection	•
Rear and right side cabin windscreen heating	+
Rear cabin work spotlight (LED or LED+)	+
Rear windscreen wiper and washer system	•
Roll down sun visor for skylight and windscreen	+
Steering column tilt adjustable	•
Storage compartment under seat	•
Travel lighting (LED or LED+)	•
USB-A and USB-C charging port	•
Work spotlight directed to the left and right (LED or LED+)	+
Work spotlights directed on to the towing hitch (LED or LED+)	+
Work spotlights on the telescopic boom (LED or LED+)	+



Tyres

Alliance A580 - 460 / 70 R 24	+
Firestone Duraforce-Utility - 460 / 70 R24	+
Michelin BibLoad - 400 / 70 R20 foam filled ¹⁾	+
Michelin BibLoad - 460 / 70 R24	+
Michelin BibLoad 500 / 70 R24 ²⁾	+
Michelin Cross Grip 460 / 70 R24	+
Michelin X Mine D2 12.00 R 24 TL ²⁾	+
Michelin XMCL - 460 / 70 R 24	+
Mitas MPT 01 - 405 / 70-20	+
Mitas MPT 01 - 405 / 70-24	•
Mitas MPT 04 - 400 / 70-24	•
Vredestein Endurion 500 / 70 R24 ²⁾	+

• = Standard

+ = As an option

¹⁾ Only available for T 38-6s, T 33-7s and T 42-7s

²⁾ Only available for T 38-7s and T 42-7s

Equipment



Safety

Acoustic reversing warning light	•
An overload warning device with automatic switch-off and acoustic and optical signal, compliant with EN 15000	•
Anti-theft protection via the ignition	+
Cabin with ROPS FOPS guard	•
CESAR (Construction Equipment Security and Registration) anti-theft protection	+
Emergency exit through rear windscreen	•
Emergency lowering of the boom	+
Emergency pack (first aid box, high-visibility vest and warning triangle)	+
Emergency Stop button	•
End position damping when lifting, sinking and telescoping in	•
Fire extinguishers	+
Folding rotating yellow beacon (also in LED)	+
Guard grille for skylight	•
Guard grille for skylight and windscreen	+
Hazard warning lights	•
Lift cylinder support (for maintenance work)	+
Mini level indicator	•
Overload warning device for Australia	+
Reversing camera	+
Reversing, sideways and boom camera	+
Tilt angle indicator on telescopic boom	+
Wheel chock (1 pc)	+
Wheel chock (2 pcs)	+
White noise reverse warning device	+



Assistance systems

Autopower selectable	+
Bucket return	+
Bucket vibrating function	+
Operator assistance, boom retraction, automatic – MultiMotion	+
Working hydraulics fine control	+



Drive

Air filter with automatic dust discharge	+
Continuous hydrostatic fan drive	•
Drive unit: 20 km/h / 105 kW / 57 kN Traction force	+
Drive unit: 30 km/h / 105 kW / 57 kN Traction force	+
Drive unit: 40 km/h / 105 kW / 57 kN Traction force	•
Drive unit: 20 km/h / 105 kW / 68 kN Traction force ¹⁾	+
Drive unit: 30 km/h / 105 kW / 68 kN Traction force ¹⁾	+
Drive unit: 40 km/h / 105 kW / 68 kN Traction force ¹⁾	+
Emission stage IIIA	+
Emission stage V	•
Hydrostatic drive	•
Manual control pack for engine and road speed	+
Permanent AWD	•
Reversible fan drive	+



Equipment

2 and 4 part hydraulic multi-coupler for Claas Scorpion quick coupler	+
Claas Scorpion universal attachment plate	+
Class Scorpion hydraulic quick coupler	+
Class Scorpion mechanical quick coupler	•
JCB Q-Fit hydraulic quick coupler	+
Liebherr Compact wheel loader hydraulic quick coupler	+
Lifting eye and hook for Class Scorpion hydraulic quick coupler	+
Manitou hydraulic quick coupler	+
Manitou mechanical quick coupler	+

• = Standard

+ = As an option

¹⁾ Only available for T 38-6s and T 42-7s

Equipment and special attachments from third-party suppliers may only be installed with the explicit permission of Liebherr.

The Liebherr Group



Global and independent: more than 75 years of success

Liebherr was founded in 1949 when, with the development of the world's first mobile tower crane, Hans Liebherr laid the foundations for a family-run company which now has more than 50,000 employees and comprises over 150 companies across every continent. The holding company of the Group is Liebherr-International AG in Bulle, Switzerland, whose shareholders are exclusively members of the Liebherr family.

Technology leadership and pioneering spirit

Liebherr is a pioneer and its forward-looking approach has seen it make important contributions to technology history over a wide variety of industries. Employees throughout the world continue to share the courage of the company founder, sharing a passion to produce innovative products and a determination to provide world-leading equipment and machinery.

Diversified product programme

Liebherr is one of the world's biggest construction machine manufacturers and provides high-quality, user-oriented products and services. Its product range includes the product segments earthmoving, material handling, deep foundation, mining, mobile and crawler cranes, tower cranes, concrete technology, maritime cranes, aerospace and transportation systems, gear technology and automation systems, refrigerators and freezers, components and hotels.

Customised solutions and maximum customer value

Liebherr solutions are characterised by precision, implementation and longevity. The company is committed to technological excellence and to providing customers with solutions that match their needs exactly. For Liebherr, customer focus does not end with delivery of a product but continues through a comprehensive range of back-up and support services.

www.liebherr.com

Liebherr-Werk Telfs GmbH

Hans-Liebherr-Straße 35 • 6410 Telfs, Austria • Phone +43 50809 6-100

lw.t.marketing@liebherr.com • www.liebherr.com • www.facebook.com/LiebherrConstruction