

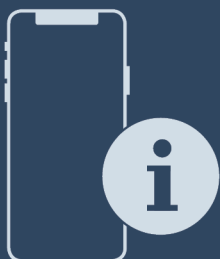

User Guide

Quality, Design and Innovation



[home.liebherr.com/fridge-manuals](http://home.liebherr.com/fridge-manuals)









# LIEBHERR

# Contents

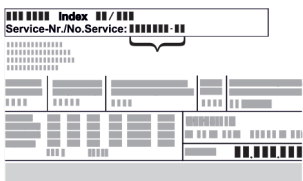
<b>1</b>	<b>General safety instructions.....</b>	<b>3</b>	<b>7.3.2</b>	<b>Reminders.....</b>	<b>37</b>
<b>2</b>	<b>Appliance at a glance.....</b>	<b>4</b>	<b>8</b>	<b>Features.....</b>	<b>37</b>
2.1	Scope of supply.....	4	8.1	Safety lock.....	37
2.2	Overview of appliances and equipment.....	4	8.2	Sensors.....	38
2.3	Special features.....	4	8.3	Sensor info .....	38
2.4	Range of use of appliance.....	5	8.4	Interfaces.....	38
2.5	Appliance noise emissions.....	5	<b>9</b>	<b>Maintenance.....</b>	<b>39</b>
2.6	Conformity.....	5	9.1	Maintenance schedule.....	39
<b>3</b>	<b>Setting up and connecting.....</b>	<b>5</b>	9.2	Defrosting appliance.....	40
3.1	Installation requirements.....	5	9.3	Cleaning the appliance.....	40
3.2	Appliance dimensions.....	6	9.4	Replacing appliance battery.....	41
3.3	Transporting the appliance.....	6	<b>10</b>	<b>Customer help.....</b>	<b>42</b>
3.4	Unpacking appliance.....	6	10.1	Technical specifications.....	42
3.5	Reversing the door opening direction.....	6	10.2	Technical fault.....	42
3.6	Aligning the door.....	14	10.3	Data recording.....	43
3.7	Removing transport lock.....	15	10.4	Customer Service.....	46
3.8	Installing door handle.....	15	10.5	Type plate.....	47
3.9	Mounting anti-tipping device.....	15	<b>11</b>	<b>Shutting down.....</b>	<b>47</b>
3.10	Installing appliance.....	16	<b>12</b>	<b>Disposal.....</b>	<b>47</b>
3.11	Setting up the appliance so it is level.....	16	12.1	Preparing appliance for disposal.....	47
3.12	Installing multiple appliances.....	16	12.2	Disposing of the appliance in an environmentally friendly manner.....	47
3.13	After installation.....	16	<b>13</b>	<b>Additional information.....</b>	<b>47</b>
3.14	Disposing of packaging.....	17	<b>14</b>	<b>Quick Start Guide for everyday use.....</b>	<b>49</b>
3.15	Connecting the appliance to the power supply.....	17			
<b>4</b>	<b>Functionality of the Touch &amp; Swipe display.....</b>	<b>17</b>			
4.1	Navigation and symbol explanation.....	17			
4.2	Menus.....	18			
4.3	Sleep mode.....	18			
<b>5</b>	<b>Putting into operation.....</b>	<b>19</b>			
5.1	Switching on appliance (first use).....	19			
<b>6</b>	<b>Storage.....</b>	<b>19</b>			
6.1	Information regarding storage.....	19			
<b>7</b>	<b>Controls.....</b>	<b>20</b>			
7.1	Control and display elements.....	20			
7.1.1	Status display.....	20			
7.1.2	Display symbols.....	20			
7.1.3	Acoustic signals.....	21			
7.2	Appliance functions.....	21			
7.2.1	Notes on the appliance functions.....	21			
7.2.2	Switching appliance on and off .....	21			
7.2.3	Temperature .....	21			
7.2.4	Temperature recording .....	22			
7.2.5	Settings menu access protection .....	22			
7.2.6	Access codes.....	23			
7.2.7	Maintenance interval reminder .....	24			
7.2.8	Language .....	24			
7.2.9	Date and time .....	25			
7.2.10	Temperature unit .....	25			
7.2.11	Display brightness .....	25			
7.2.12	Alarm tone .....	26			
7.2.13	Key tone .....	26			
7.2.14	WiFi connection .....	26			
7.2.15	LAN connection .....	28			
7.2.16	Device information .....	28			
7.2.17	Operating hours .....	29			
7.2.18	Software .....	29			
7.2.19	Defrosting .....	29			
7.2.20	Data download (data backup) .....	30			
7.2.21	Sensor calibration .....	30			
7.2.22	Temperature alarm .....	31			
7.2.23	Door alarm .....	32			
7.2.24	Alarm simulation .....	32			
7.2.25	Alarm log .....	33			
7.2.26	Alarm forwarding .....	34			
7.2.27	Demo mode .....	34			
7.2.28	Resetting to factory settings .....	35			
7.3	Message.....	35			
7.3.1	Warnings.....	35			

The manufacturer is continually working on the further development of all types and models. Please be aware that we reserve the right to make changes to the shape, equipment and technology.

Symbol	Explanation
	<p><b>Read instructions</b></p> <p>Please read the information in these instructions carefully to understand all of the benefits of your new appliance.</p>
	<p><b>Additional information on the Internet</b></p> <p>The digital manual with additional information and in other languages can be found via the QR code on the front of the manual or by entering the service number at <a href="http://home.liebherr.com/fridge-manuals">home.liebherr.com/fridge-manuals</a>.</p> <p>The service number can be found on the serial tag:</p>  <p style="text-align: right;"><i>Fig. Example illustration</i></p>
	<p><b>Check appliance</b></p> <p>Check all parts for transport damage. If you have any complaints, please contact your agent or customer service.</p>
	<p><b>Differences</b></p> <p>These instructions apply to a range of models, so differences are possible. Sections that apply to certain models only are marked with an asterisk (*).</p>

Symbol	Explanation
	<b>Instructions and results</b> Instructions are marked with a ▶. Results are marked with a ▷.
	<b>Videos</b> Videos about the appliances are available on the YouTube channels of Liebherr-Hausgeräte.

## Open source licences:

The appliance contains software components that use open source licences. Information on the open source licences used can be found here: [home.liebherr.com/open-source-licences](https://home.liebherr.com/open-source-licences)

These operating instructions apply to:

- SFFvh 4001
- SFFvh 5501

## 1 General safety instructions

Please keep these operating instructions in a safe place so you can refer back to them at any time.

If you pass the appliance on, please hand these operating instructions to the next user.

Read these operating instructions carefully before use to ensure safe and correct use of the appliance. Follow the instructions, safety instructions and warning messages included at all times. They are important for ensuring you can operate and install the appliance safely and without any problems.

### Danger for the user:

- This appliance may only be used by specialist and laboratory personnel who have been trained for this purpose and are familiar with all safety measures pertaining to laboratory work. Children and persons with reduced physical, sensory or mental capabilities or lack of experience and knowledge must not commission or operate this appliance.
- The socket must be easily accessible so that the appliance can be disconnected quickly from the electricity supply in an emergency. It must not be located in the area behind the appliance.
- When disconnecting the appliance from the supply, always take hold of the plug. Do not pull the cable.
- In the event of a fault pull out the mains plug or deactivate the fuse.
- **WARNING:** Do not damage the mains power cable. Do not operate the appliance with a defective mains power cable.
- **WARNING:** Multiple sockets/distributors and other electronic equipment (such as halogen transformers) must not be placed or operated at the rear of the appliance.
- **WARNING:** Keep ventilation openings, in the appliance enclosure or in the built-in structure, clear of obstruction.
- Only customer service or other specially trained staff may repair or perform other operations on the appliance.
- Only assemble, connect and dispose of the appliance according to the instructions.

### Fire hazard

- The coolant used (information on the model plate) is ecofriendly but also flammable. Any leaking coolant may ignite.
  - **WARNING:** Do not damage refrigeration circuit.
  - Do not handle ignition sources inside the appliance.

- **WARNING:** Do not use electrical appliances in the fridge compartment which do not comply with the design recommended by the manufacturer.
- If the refrigerant leaks: remove any naked flames or ignition sources from the vicinity of the leakage point. Properly air the room. Inform customer services.
- Do not operate the appliance close to explosive gases.
- Do not store or use petrol or other flammable gases and liquids close to the appliance.
- Do not store any explosive substances, such as aerosol containers with flammable propellant gas, in the appliance. To identify these spray cans, look for the list of contents printed on the can, or a flame symbol. Gases possibly escaping may ignite due to electrical components.
- Keep burning candles, lamps and other items with naked flames away from the appliance so that they do not set the appliance on fire.
- Alcoholic liquids or other containers with alcohol inside must only be stored tightly sealed. Any alcohol that leaks out may be ignited by electrical components.

### Danger of tipping and falling:

- **WARNING:** In order to prevent danger due to an unstable appliance, it must be fixed in accordance with the instructions.
- Do not misuse the plinth, drawers, doors etc. as a step or for support.

### Danger of frostbite, numbness and pain:

- Avoid prolonged skin contact with cold surfaces or refrigerated/frozen goods or take protective measures, e.g. wear gloves.

### Danger of injury and damage:

- **WARNING:** Do not use mechanical equipment or other methods to speed up the defrosting process other than those recommended by the manufacturer.
- **WARNING:** Risk of injury due to electric shock! There are live electrical parts under the cover. Only have the LED interior lighting replaced or repaired by customer service or other suitably trained professionals.
- **NOTICE:** Appliance must only be used using original manufacturer accessories or using accessories from other providers approved by the manufacturer. The user bears the risk of using accessories which are not approved.

### Risk of crushing

- Do not hold the hinge when opening and closing the door. Fingers may get caught.

### Specialist personnel qualifications:

The appliance may only be installed, tested, maintained, and commissioned by specialist personnel who are familiar with the installation, commissioning, and operation of the appliance. Specialist personnel are persons who, on account of their specialist training, knowledge and experience as well as their knowledge of the relevant standards, are able to assess and perform the work assigned to them and identify potential hazards. They must have training, instruction, and authorisation to work on the appliance.

### Symbols on the appliance:



This symbol may be located on the compressor. It relates to the oil in the compressor and makes reference to the risk that: **Swallowing or inhaling can be fatal.** This advice is only relevant to recycling. There is no danger in normal operation.

# Appliance at a glance



**WARNING:** Danger of fire / flammable materials. This symbol is located on the compressor and indicates the danger of flammable materials. Do not remove the sticker.



The symbol is located on the back of the appliance near the alarm relay and indicates the following danger: **Electric shock!** Even if an appliance is disconnected from the mains there may still be extraneous voltage. Do not remove sticker.



This or a similar sticker may be located on the rear of the appliance. This sticker indicates that there are vacuum insulation panels (VIP) or perlite panels in the door and/or housing. This advice is only relevant to recycling. Do not remove the sticker.



**Li-ion**

This or a similar sticker may be located on the rear of the appliance. It refers to the Li-ion self-charging battery installed. This advice is only relevant to recycling. Do not remove sticker.



**WARNING: Cold surface!** Only touch with suitable hand protection. This or similar sticker may be on the appliance and indicates the danger of frostbite.

Please note the warning messages and other specific advice in the other chapters:

	<b>DANGER</b>	Indicates an immediately hazardous situation which will lead to death or serious injuries if it is not avoided.
	<b>WARNING</b>	Indicates a hazardous situation which will lead to death or serious injuries if it is not avoided.
	<b>CAUTION</b>	Indicates a hazardous situation which will lead to minor or moderate injuries if it is not avoided.
	<b>NOTICE</b>	Indicates a hazardous situation which may lead to damage to property if it is not avoided.
	<b>Note</b>	Indicates useful instructions and tips.

## 2 Appliance at a glance

### 2.1 Scope of supply

Check all parts for transport damage. If you have any complaints, please contact your dealer or Customer Service. (see 10.4 Customer Service)

The delivery comprises the following parts:

- Free-standing appliance
- Equipment \*
- Installation materials \*
- Operating instructions
- Service brochure
- Quality certificate \*
- Mains cable
- Wall fastening kit

### 2.2 Overview of appliances and equipment

SFFvh 5501

SFFvh 4001

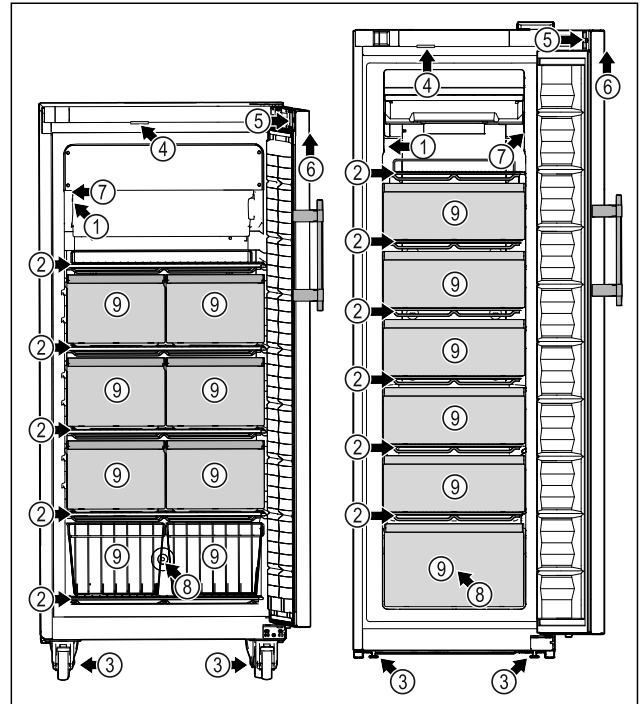

Fig. 1 Example illustration

#### Equipment

- |                               |  |
|-------------------------------|--|
| (1) Type plate                | (6) Control elements and temperature display |
| (2) Shelves                   | (7) C sensor                                 |
| (3) Adjustable foot / roller* | (8) Sensor feedthrough                       |
| (4) Lighting*                 | (9) Drawer/wire basket                       |
| (5) Lock                      |  |

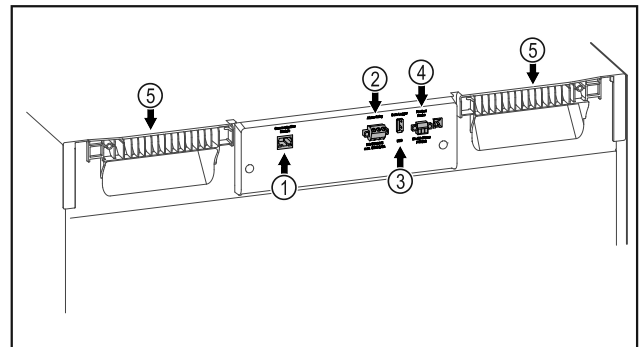

Fig. 2 Example illustration of the rear

#### Equipment

- |                                 |                             |
|---------------------------------|-----------------------------|
| (1) LAN/WLAN interface*         | (4) Connection for P sensor |
| (2) Potential-free alarm output | (5) Carrying aid            |
| (3) USB interface               |                             |

### 2.3 Special features

#### Note

You can obtain accessories from customer service (see 10.4 Customer Service) or from specialised dealers via the dealer search on our service page on the Internet:

[home.liebherr.com](http://home.liebherr.com)

SmartModule
The appliance is fitted with a SmartModule. It is a WLAN and LAN interface for the connection between the appliance and an external documentation and alarm system such as Liebherr SmartMonitoring dashboard. Liebherr SmartMonitoring dashboard is not available in all countries. Check availability via the QR code (see 7.2.14 WiFi connection ) by entering your model.

Retrofitting drawers
When retrofitting drawer systems in Liebherr refrigerators/freezers that are used to store temperature-sensitive materials such as medicines requiring refrigeration and refrigerated goods that are subject to special standard requirements, a temperature qualification is required. Retrofitting drawers in Liebherr refrigerators/freezers can lead to spoilage of the stored goods or damage to the stored goods. Therefore, retrofitting must only be carried out by authorised service providers of the refrigerator/freezer manufacturer.

Climate class (X)	max. room temperature	max. rel. humidity
7	35 °C	75%

### Note

The minimum permitted room temperature at the setup location is 10 °C.

## 2.5 Appliance noise emissions

The A-weighted emission sound pressure level during operation of the appliance is under 70 dB(A) (sound power rel. 1 pW).

## 2.6 Conformity

The coolant circuit has been tested for leak-tightness. The appliance complies with the relevant safety regulations and directives.

# 3 Setting up and connecting

## 3.1 Installation requirements

The installation conditions are crucial to ensure that you can operate your appliance safely, efficiently and without problems.

- Observe all safety instructions.
- Consider the location and position in the room.



### WARNING

Danger of fire due to incorrect positioning!

If the mains cable or plug touches the back of the appliance, the vibration can damage the mains cable or the plug resulting in a short circuit.

- ▶ Make sure the mains cable is not trapped under the appliance when you position the appliance.
- ▶ Stand the appliance so that it is not touched by connectors or main cables.
- ▶ Do not connect any appliances to sockets in the area of the back of the appliance.
- ▶ Do **not** place and operate multi-sockets/power distributors and other electronic devices (such as halogen transformers) at the back of the appliances.



### WARNING

Fire hazard due to dampness!

If live parts or the mains lead become damp this may cause short circuits.

- ▶ The appliance is designed for use in enclosed areas. Do not operate the appliance outdoors or in areas where it is exposed to splash water or damp conditions.



### WARNING

Leaking coolant and oil!

Fire. The coolant contained in the appliance is eco-friendly, but also flammable. The oil contained in the appliance is flammable. Escaping coolant and oil can ignite if the concentration is high enough and in contact with an external heat source.

- ▶ Do not damage the pipelines of the coolant circuit and the compressor.

## 2.4 Range of use of appliance

### Intended use

This laboratory freezer is suitable for professional storage of products at temperatures between -9 °C and -35 °C.

Typical products to be stored include research samples, reagents, laboratory inventory etc.

The appliance meets the requirements of DIN 13277 Refrigerators and freezers for laboratory and medical applications.

The storage of temperature-sensitive substances requires the use of an independent, continuous monitoring alarm system. This alarm system must be designed in such a way that a responsible person can register any alarm status so that appropriate action can be taken.

### Foreseeable incorrect use

Do not use the appliance for the following applications:

- Storage and refrigeration of:
  - Chemically unstable, flammable or corrosive substances
  - Blood, plasma or other body fluids for the purpose of infusion, application or introduction in the human body.
- Use in potentially explosive atmospheres.
- Use outdoors or in areas exposed to dampness and splashing water.

Improper use of the appliances will result in goods stored being damaged or spoiled.

### Climate classes

The applicable climate class for your appliance is printed on the type plate.

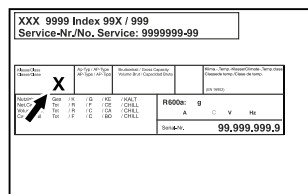

Fig. 3 Type plate

- (X) This climate class indicates the ambient conditions in which the appliance can be safely operated.

# Setting up and connecting

## 3.1.1 Installation site

- A dry and well-ventilated room is an optimum installation location.
- If the appliance is installed in a very damp environment, condensation may form on the appliance exterior. Always make sure there is good ventilation and aeration at the installation site.
- The more refrigerant there is in the appliance, the larger than room must be in which it is located. In rooms that are too small, a leak can produce a flammable gas/air mixture. For every 8 g of refrigerant, the installation room must be at least 1 m<sup>3</sup> in size. Information on the refrigerant contained is given on the type plate inside the appliance.
- The floor on which the appliance stands must be horizontal and level.
- The site of use must be able to bear the weight of the device including the maximum load. (see 10.1 Technical specifications)

## 3.1.2 Position in space

- Do not place the appliance in direct sunlight or near radiators or similar sources of heat.
- Always position the appliance with the rear directly on the wall.
- Use in hazardous areas is not permitted.

## 3.2 Appliance dimensions

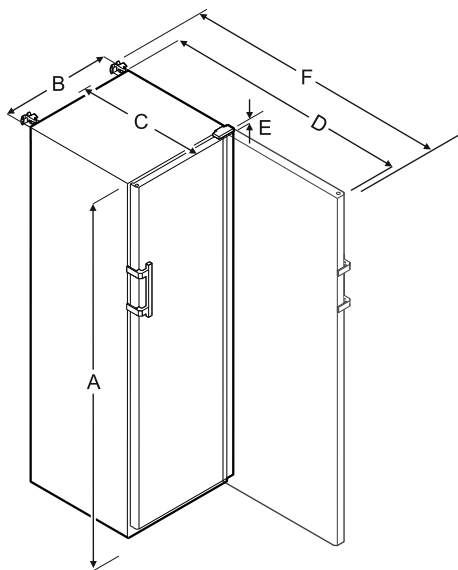

	SFFvh 4001	SFFvh 5501
A	1884 mm	1793 mm
B	597 mm	747 mm
C	664 mm	779 mm
D	1203 mm	1468 mm
E	23 mm	23 mm
F	1241 mm	1506 mm

- A = appliance height including feet/castors
- B = appliance width without handle [handle depth = 45 mm]
- C = appliance depth without handle [handle depth = 45 mm]
- D = appliance depth with door open
- E = hinge height
- F = appliance depth with protruding handle and anti-tipping device

## 3.3 Transporting the appliance



### WARNING

Risk of injury and damage due to the appliance tipping over!  
 ► Pay attention to uneven floors and ramps when transporting appliances.

### 3.3.1 Transporting the appliance for initial use

Ensure that the following requirements are met:

- The appliance is packaged.
- The appliance is upright.
- Transport the appliance with the help of two people.
- Unpacking the appliance.

### 3.3.2 Transporting the appliance after initial use

Observe the following instructions if you wish to transport or move the appliance again after initial use.

Ensure that the following requirements are met:

- The appliance is emptied.
- The appliance is upright.
- Appliance with door(s): Door is secured against accidental opening.
- Appliance with telescopic unit: The telescopic unit is secured against accidental opening.
- Appliance with adjustable feet: Adjustable feet are screwed in.

If you want to transport the appliance over a short distance:\*

- Move the appliance using the rollers on the ground.\*

If you want to transport the appliance over a greater distance:\*

- Transport the appliance with the help of two people.

After transport:

- Unscrew the adjustable feet on the appliance.\*
- Align the appliance.

## 3.4 Unpacking appliance

- Check the appliance and the packaging for damage during transport. Contact the supplier immediately if you suspect any damage. Do not connect appliance to the power supply.
- Remove all packaging materials from the rear or the side walls of the fridge that may prevent proper installation or prevent air flow and ventilation.

## 3.5 Reversing the door opening direction

### Tools

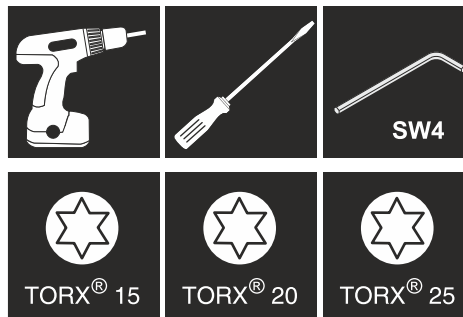



## WARNING

Risk of injury if the door is not reversed correctly!  
 ► Replace the door hinge with specialist personnel.



## WARNING

Risk of injury and material damage due to heavy door!  
 ► Only perform the conversion if you can carry a weight of 25 kg.  
 ► Always have someone help you carry out the conversion.

## NOTICE

Live parts!  
 Damage to electrical components.  
 ► Remove the mains plug before you reverse the door.

► Open the door.

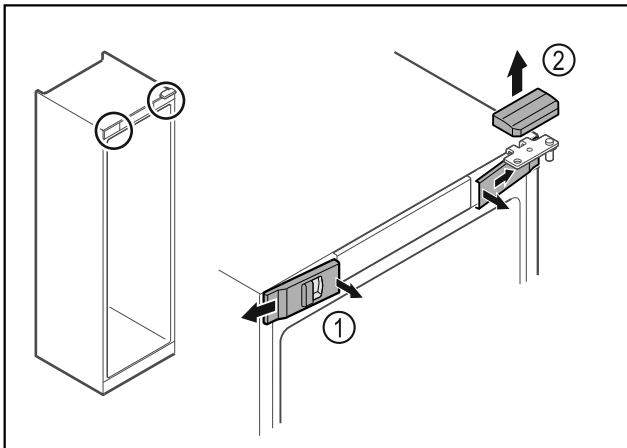

Fig. 4

- Unlatch the front covers Fig. 4 (1) on the inside and remove them sideways.
- Lift off the upper cover Fig. 4 (2).

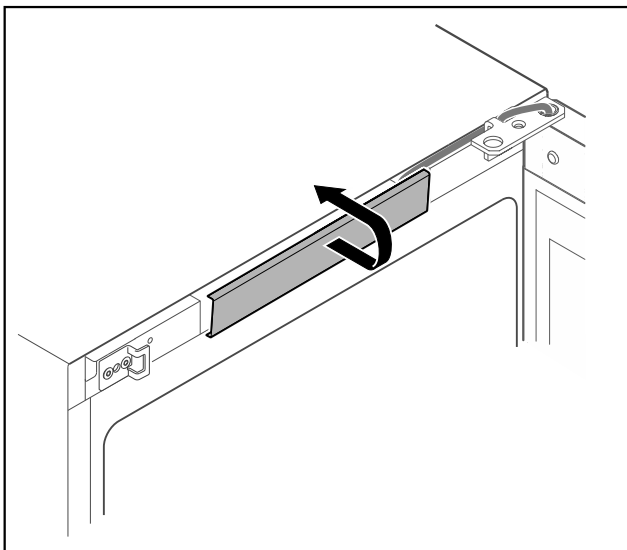

Fig. 5

- Unlatch the middle cover and remove it.

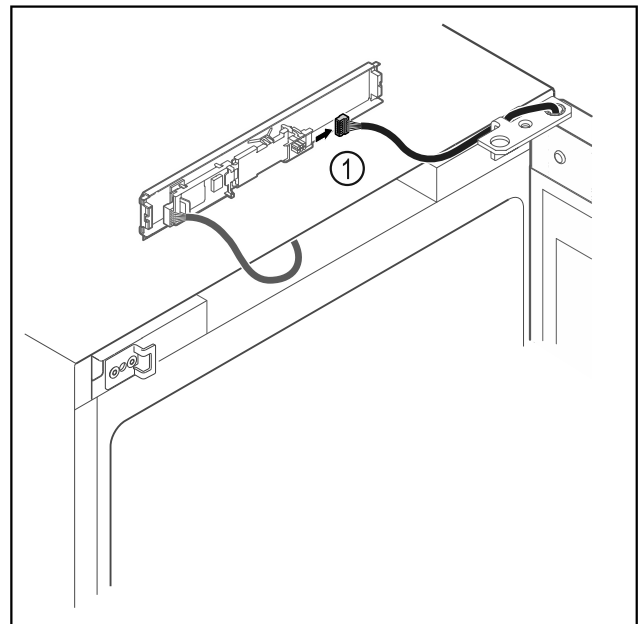

Fig. 6

- Disconnect the plug Fig. 6 (1) from the circuit board.

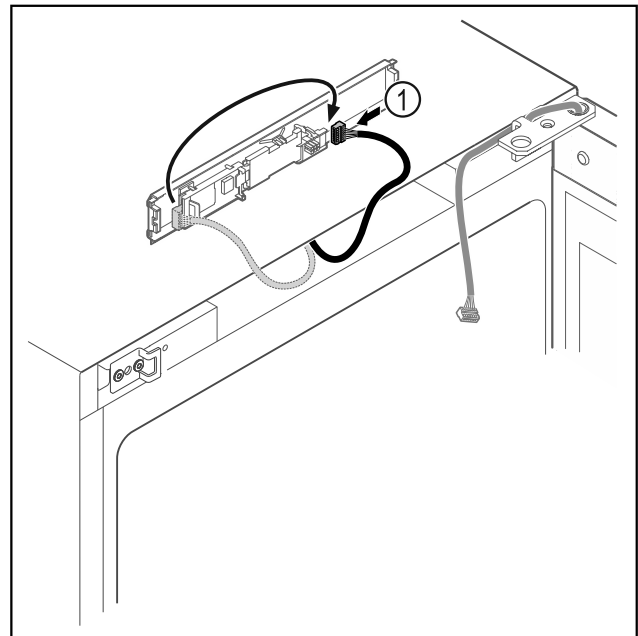

Fig. 7

- Connect the plug Fig. 7 (1) to the circuit board.

# Setting up and connecting

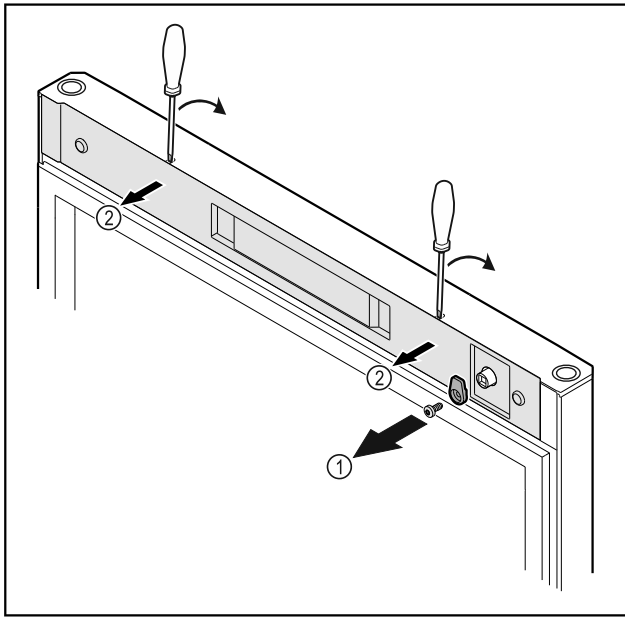

Fig. 8

- ▶ Unscrew the door latch Fig. 8 (1).
- ▶ Unlatch the cover Fig. 8 (2) with a small screwdriver and remove it.

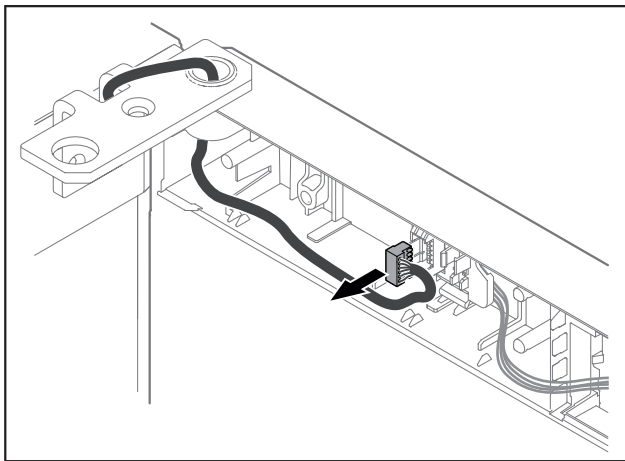

Fig. 9

- ▶ Remove the plug from the plug holder.
- or-

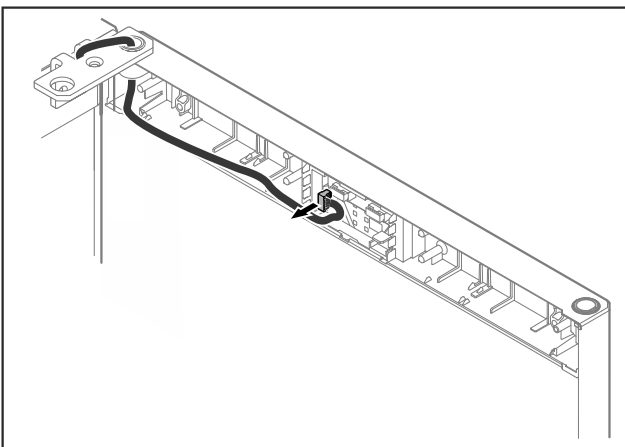

Fig. 10

- ▶ Remove the plug from the circuit board.

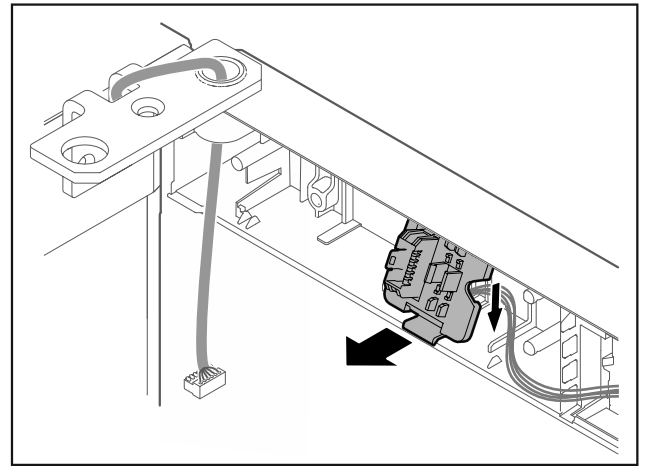

Fig. 11 The installation position for the plug holder can be rotated by 180°.\*

- ▶ Unlatch the plug holder.\*

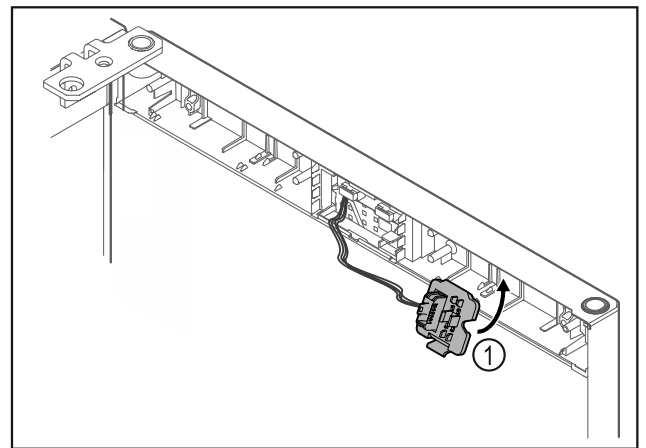

Fig. 12

- ▶ Engage the plug holder Fig. 12 (1) on the opposite side.\*

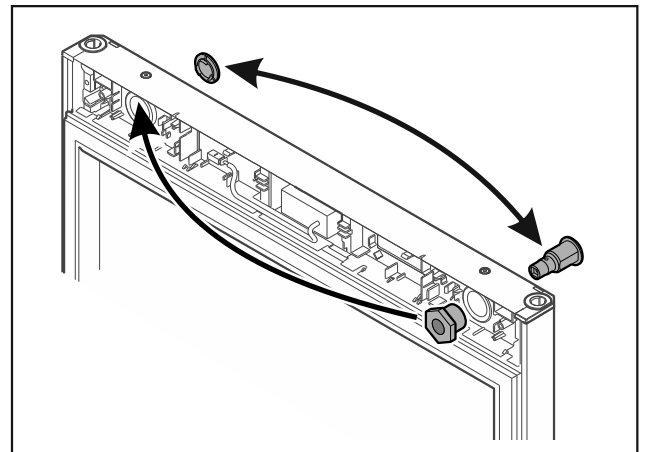

Fig. 13

- ▶ Put the lock and cover on the opposite side.
- or-

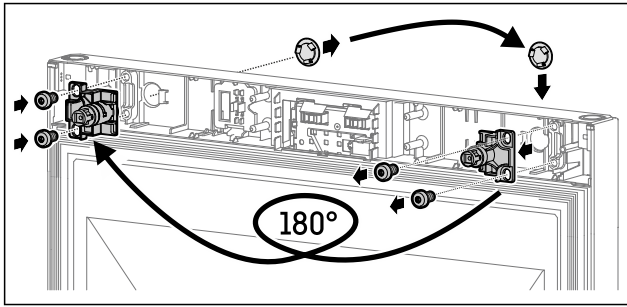

Fig. 14

- Put the lock and cover on the opposite side.

### NOTICE

Risk of injury if the door tips out!

- Hold the door.

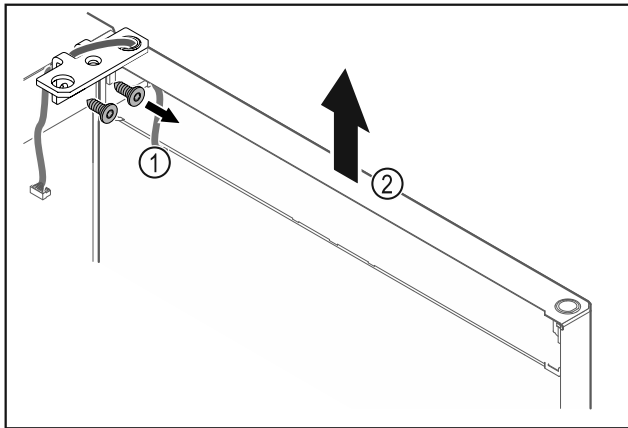

Fig. 15

- Unscrew the hinge Fig. 15 (1).
- Lift the door with the hinge straight up by Fig. 15 (2) roughly 200 mm and take it off.
- Carefully place the door on a soft surface.

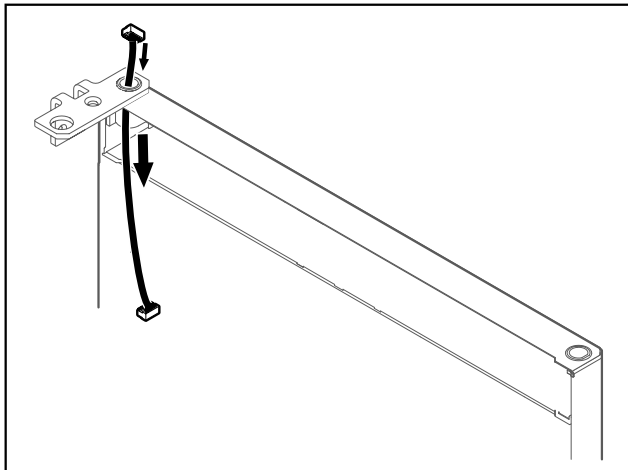

Fig. 16

- Carefully pull out the cable.

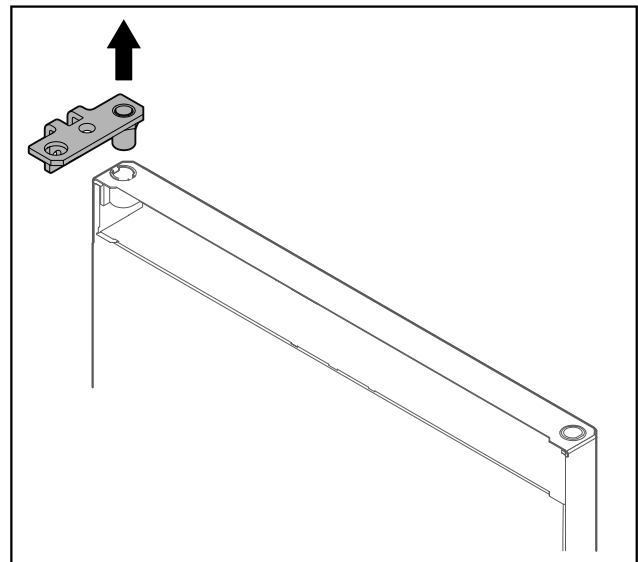

Fig. 17

- Pull out the hinge.

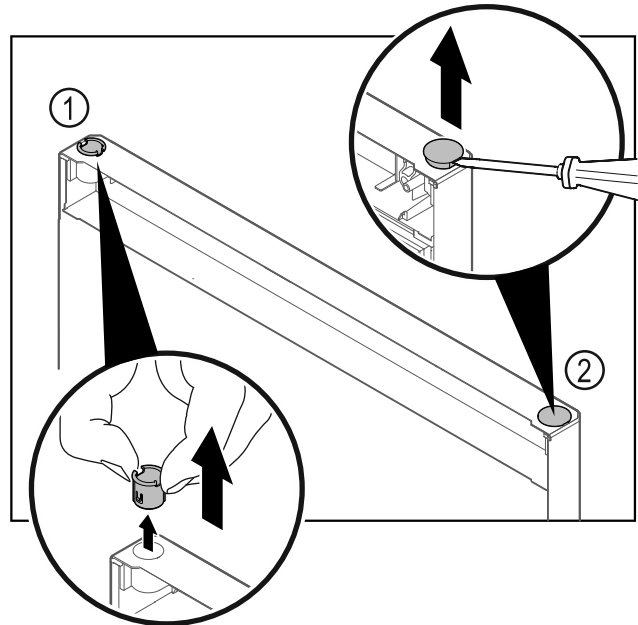

Fig. 18

- Pull out the hinge bushing Fig. 18 (1) with your fingers.
- Carefully lift the cover plug Fig. 18 (2) with a slotted screwdriver and pull it out.

# Setting up and connecting

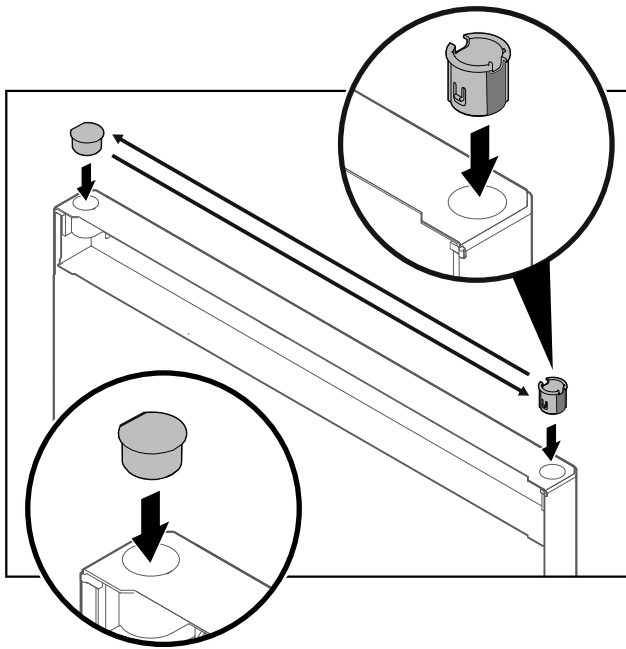

Fig. 19

- ▶ Insert hinge bushing and cover plug on the opposite side (the flattened sides face outwards).

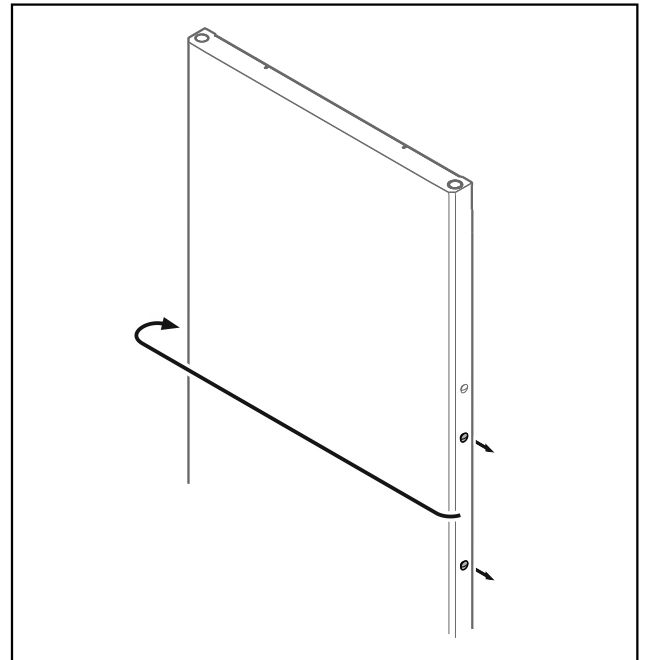

Fig. 21

- ▶ Put the stopper on the opposite side.

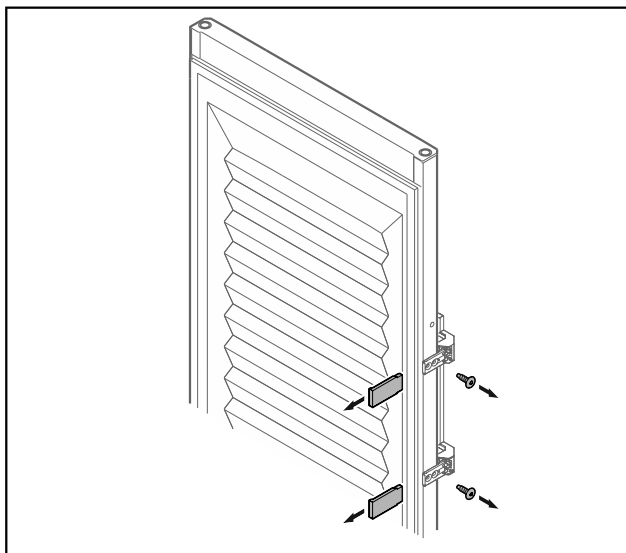

Fig. 20 Insulated door

- ▶ Remove the panels.
- ▶ Unscrew the handle.

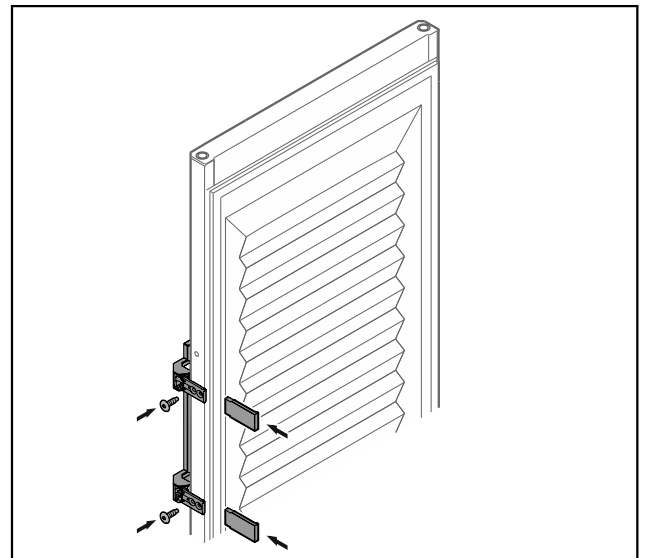

Fig. 22 Insulated door

- ▶ Screw the handle onto the opposite side.
- ▶ Attach the panels.

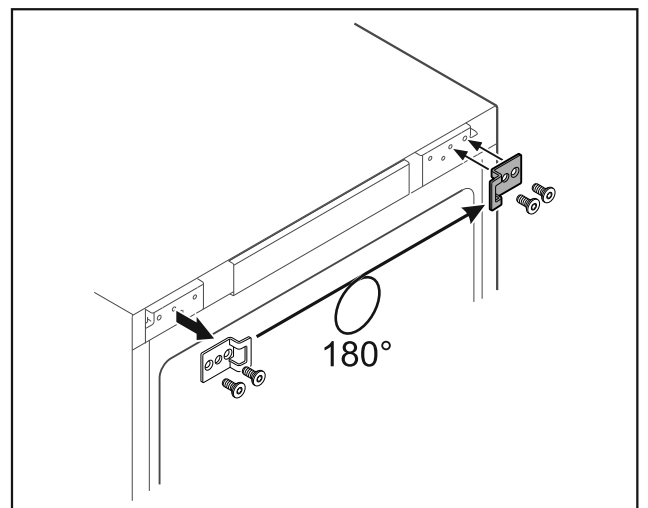

Fig. 23

- ▶ Put the closing bracket on the opposite side.

**Note**

The holes are pre-marked and must be pierced with the self-tapping screws.

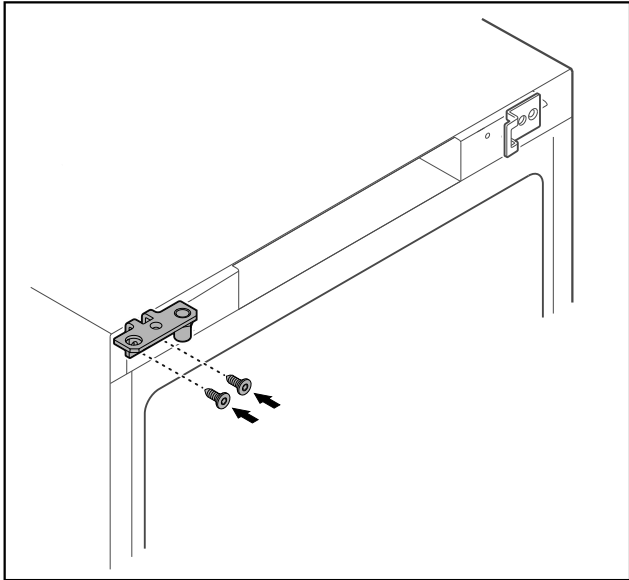

Fig. 24

- ▶ Move the hinge to the opposite side.



**WARNING**

Risk of injury and material damage if the door tips out!

- ▶ Tighten the bearing pins to the specified torque.

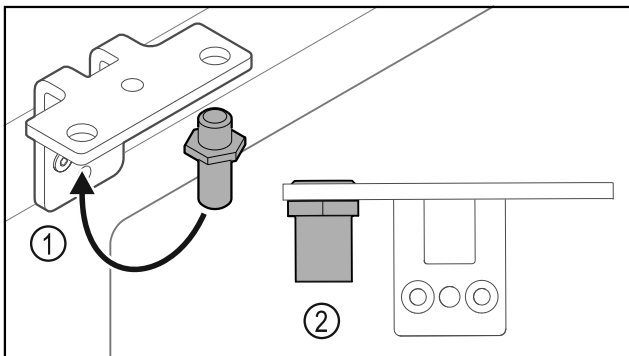

Fig. 25

- ▶ Put the pin back into the hinge Fig. 25 (1).
- ▶ Tighten the pin Fig. 25 (2) to a **torque of 12 Nm**.
- ▶ Unscrew the hinge again.

**NOTICE**

Risk of injury due to tensioned spring!

- ▶ Do not disassemble the door closing system Fig. 26 (1).

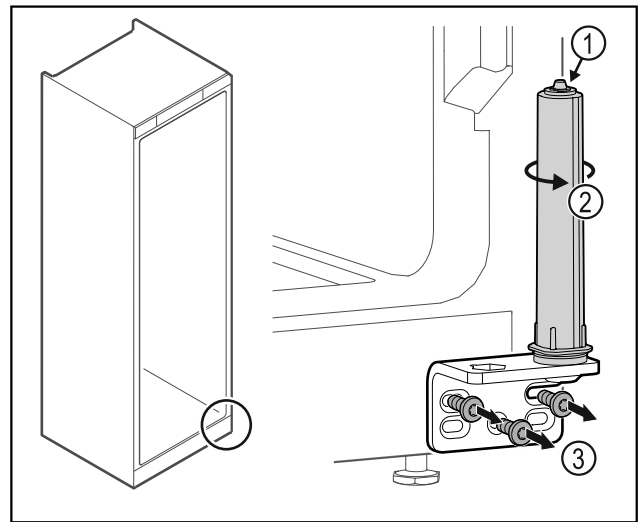

Fig. 26

- ▶ Turn the closing system Fig. 26 (2) until it clicks.
- ▶ The tension of the closing system is released.
- ▶ Unscrew the hinge Fig. 26 (3).

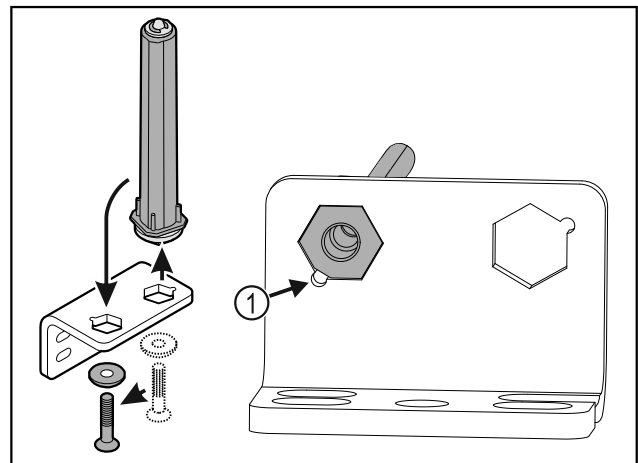

Fig. 27

- ▶ Put the door closing system in the hinge.
- ▶ Make sure the pin chamfer Fig. 27 (1) faces the round hole when you put it in.

-or-

**Note**

Incorrect alignment of the height adjustment washers. Nuts no longer have sufficient hold.

- ▶ The washer must lock into the underside of the closing system.

# Setting up and connecting

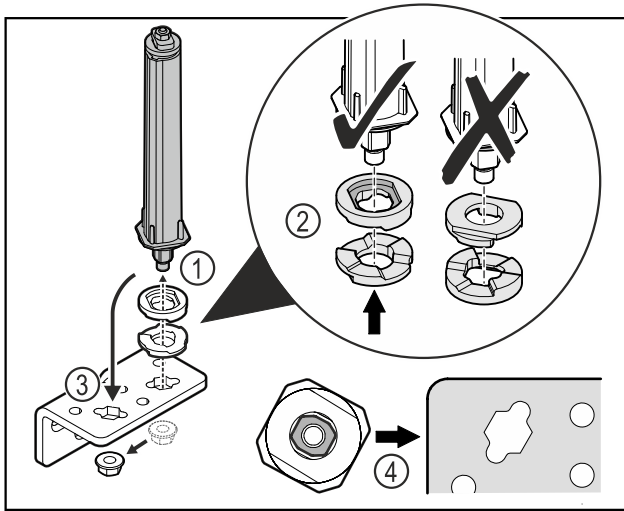

Fig. 28

- ▶ Loosen the nut and remove the door closing system Fig. 28 (1).
- ▶ Observe the correct alignment of the height adjustment washers Fig. 28 (2).
- ▶ Put the door closing system in the hinge and fix in place with the nut Fig. 28 (3).
- ▶ Observe the correct alignment of the door closing system when doing so Fig. 28 (4).

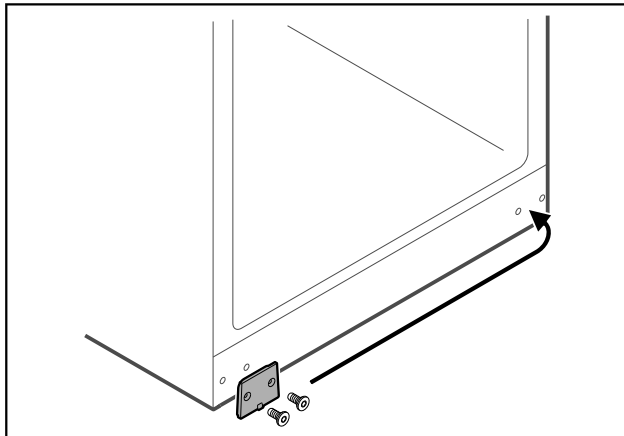

Fig. 29

- ▶ Put the cover plate on the opposite side.

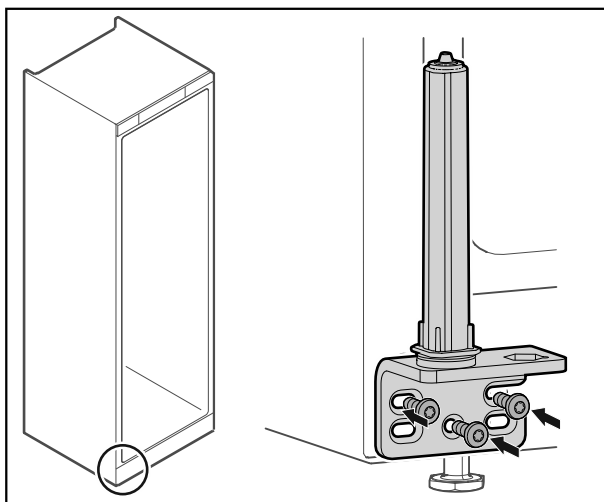

Fig. 30

- ▶ Screw the hinge onto the opposite side.

## Note

Correct alignment and tension are important for the closing system to work properly.

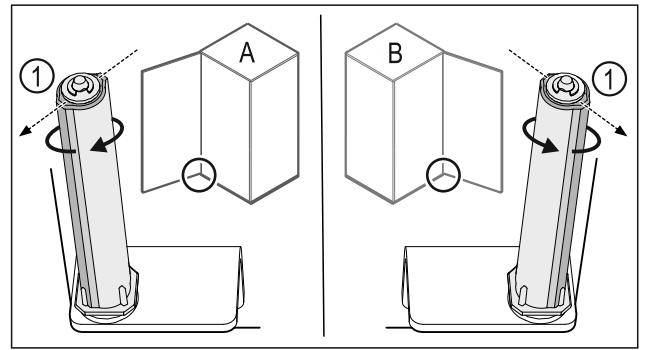

Fig. 31 Left-hinged (A) / Right-hinged (B)

- ▶ Turn the closing system against the resistance until the bar of the closing system Fig. 31 (1) points outwards.
- ▶ The closing system automatically stays in this position.
- ▶ The closing system is now aligned and tensioned.

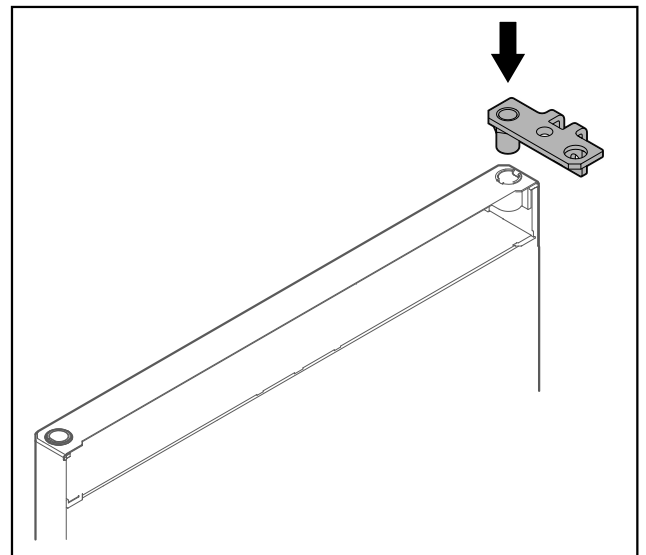

Fig. 32

- ▶ Put the hinge into the door.

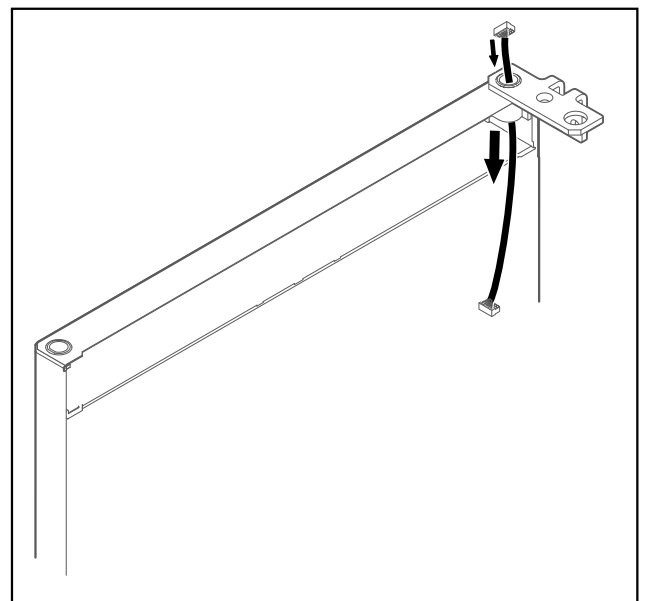

Fig. 33

- ▶ Carefully push the cable through.

## NOTICE

Risk of injury if the door tips out!

- ▶ Hold the door.

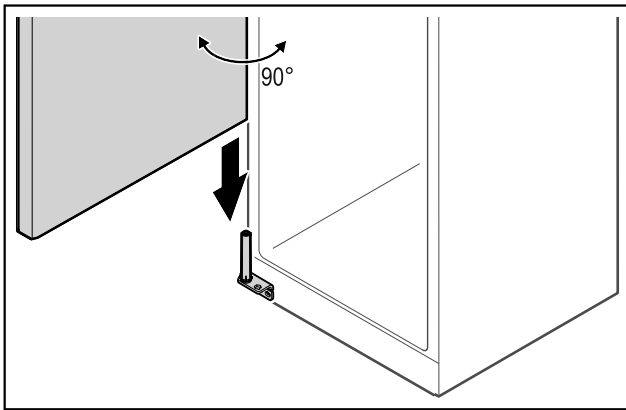

Fig. 34

- ▶ Together with a second person, lift the door from the ground.
- ▶ Carefully put the door on the closing system with the door opened at a 90° angle.

## NOTICE

Material damage due to incorrect mounting!

- ▶ Do not pinch the cable when mounting the hinge.

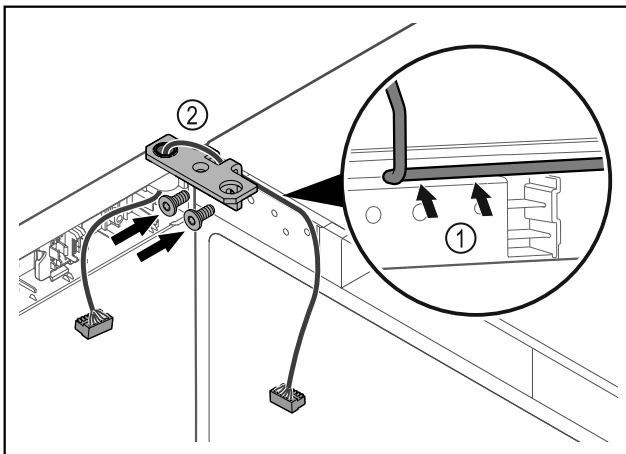

Fig. 35

- ▶ Feed the cable through the recess in the hinge and lay it carefully Fig. 35 (1).
- ▶ Screw on the hinge Fig. 35 (2).

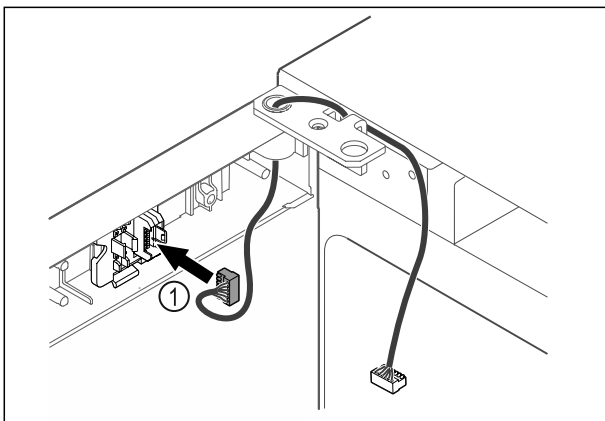

Fig. 36

- ▶ Put the plug Fig. 36 (1) in the plug holder.

-or-

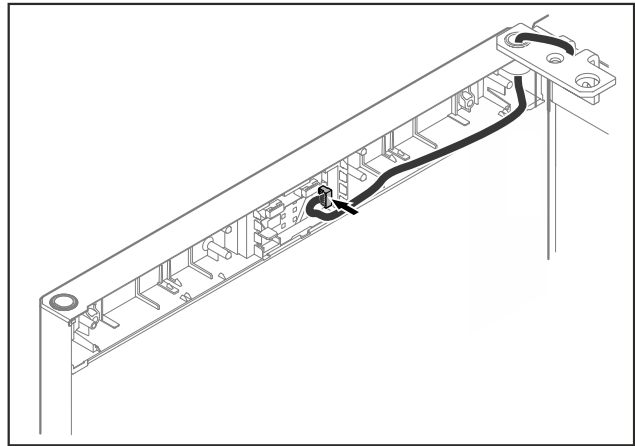

Fig. 37

- ▶ Plug the connector into the circuit board.

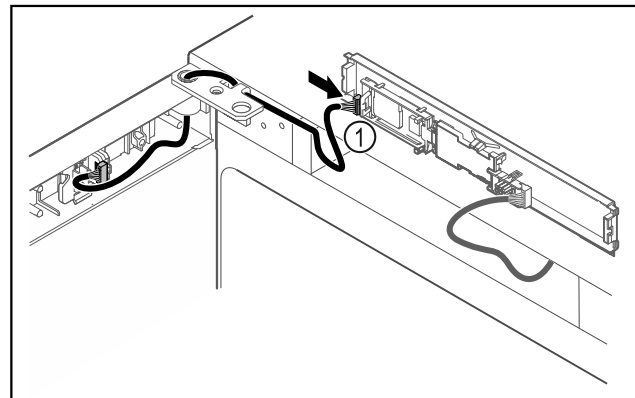

Fig. 38

- ▶ Connect the plug Fig. 38 (1) to the circuit board.

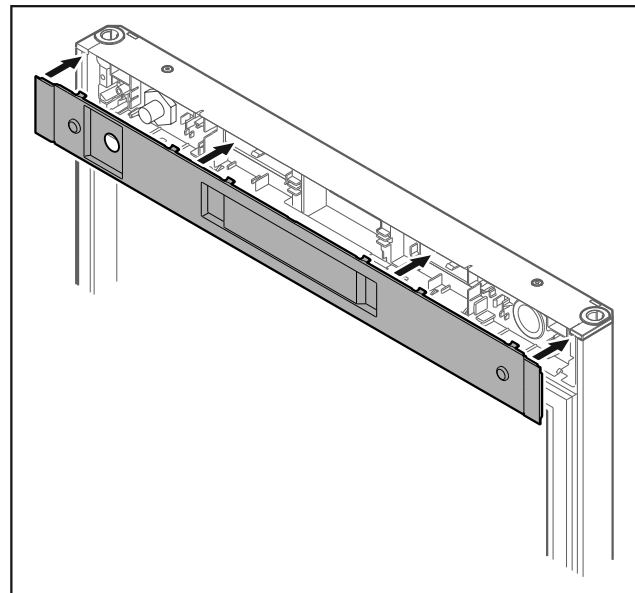

Fig. 39

- ▶ Set the cover back in place.

# Setting up and connecting

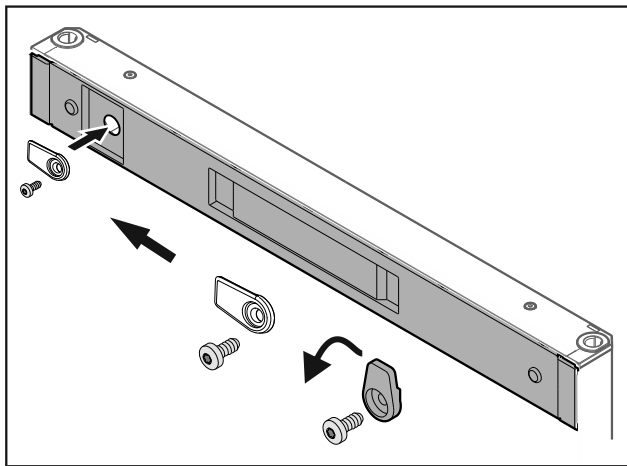

Fig. 40

- ▶ Screw on the door latch.

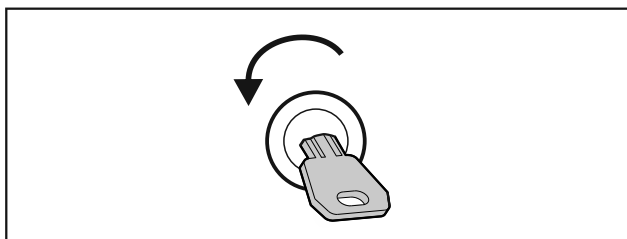

Fig. 41

- ▶ Open the door.

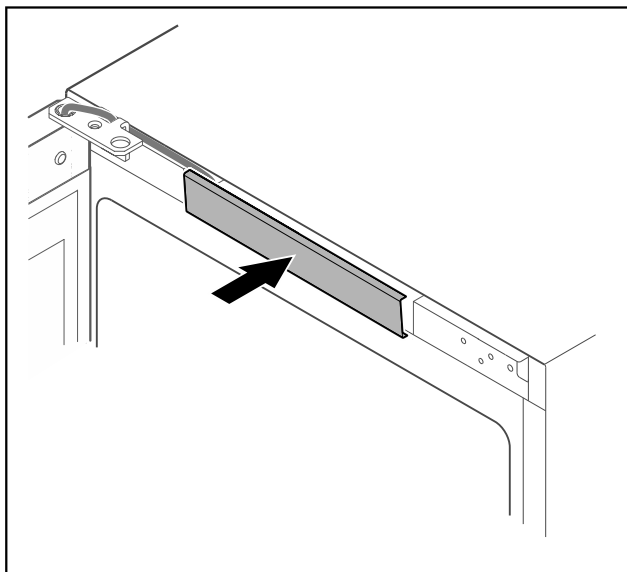

Fig. 42

- ▶ Snap in the middle cover.

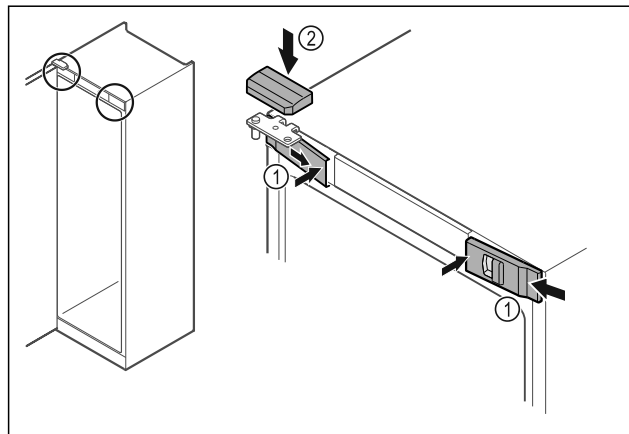

Fig. 43

- ▶ Hook in the front covers Fig. 43 (1) on the side and snap them into place on the inside.
- ▶ Snap on the top cover Fig. 43 (2) from above.
- ▶ Close the door.
- ▶ The door has now been reversed.

## 3.6 Aligning the door

If the door is not straight, you can adjust it on the lower hinge.

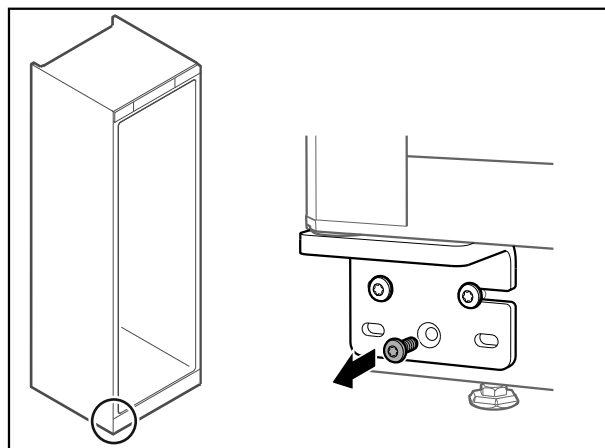

Fig. 44

- ▶ Remove the middle screw on the lower hinge.

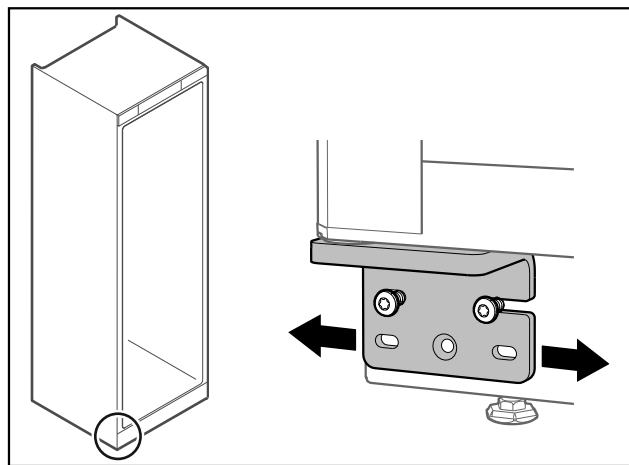

Fig. 45

- ▶ Slightly undo both screws and move the door with the hinge to the left or right.
- ▶ Fully tighten the screws (the middle screw is no longer needed).
- ▶ The door is now straight.

## 3.7 Removing transport lock

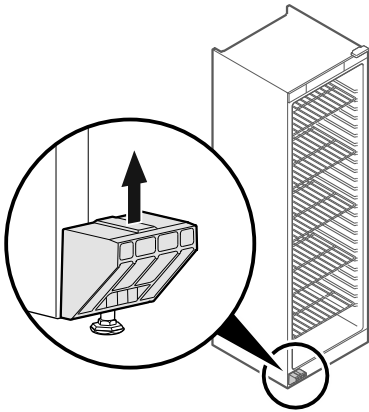

Fig. 46

- ▶ Remove transport lock in upwards direction.
- ▶ Base holder remains on the appliance.

## 3.8 Installing door handle

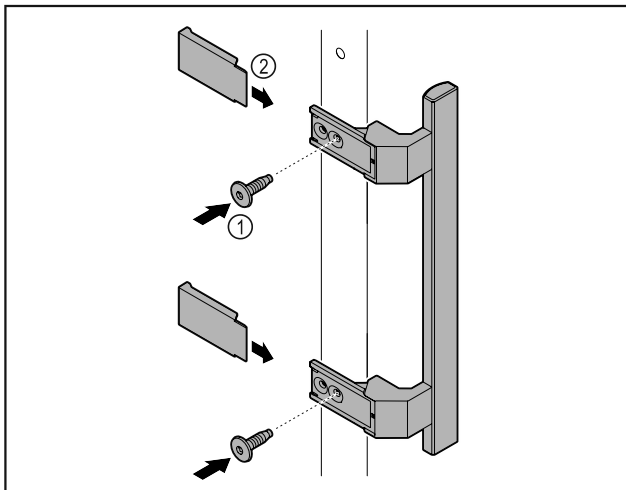

Fig. 47

- ▶ Attach handle from accessory kit to the door using the screws Fig. 47 (1) supplied.
- ▶ Put on cover Fig. 47 (2).
- ▶ Insert the plug from the accessory pack on the opposite side.\*

## 3.9 Mounting anti-tipping device

### Tools



Fig. 48



### WARNING

Danger of injury and damage due to appliance tipping over! Danger to life and material damage to the appliance. An appliance without an anti-tip device fitted can tip over if you open the door or pull out shelves, for example.

- ▶ Before putting the appliance into operation: **Always** fit the anti-tilt device according to the instructions.

Prevent appliance from tipping over.

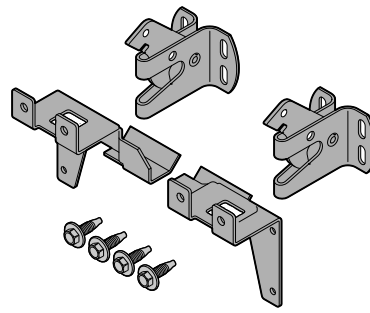

Fig. 49

The anti-tilt device is included with the device. It consists of two retaining parts, two securing hooks and four self-tapping screws (4 x 14).

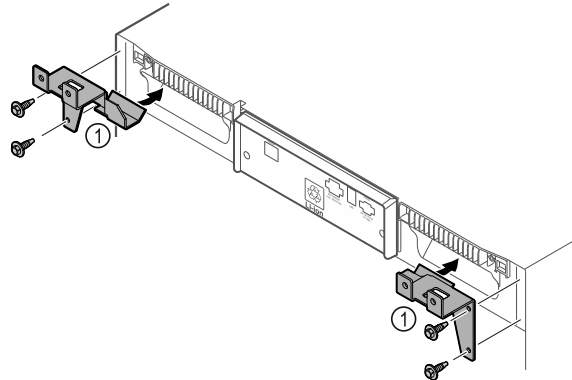

Fig. 50

- ▶ Fit the retaining parts Fig. 50 (1) to the device with self-tapping screws.
- ▶ Push appliance with retaining parts mounted against the wall.

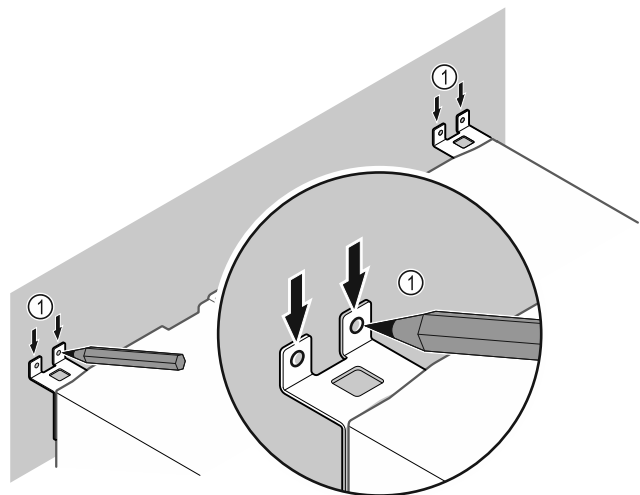

Fig. 51

- ▶ Make markings on the wall Fig. 51 (1).
- ▶ Remove appliance.

# Setting up and connecting

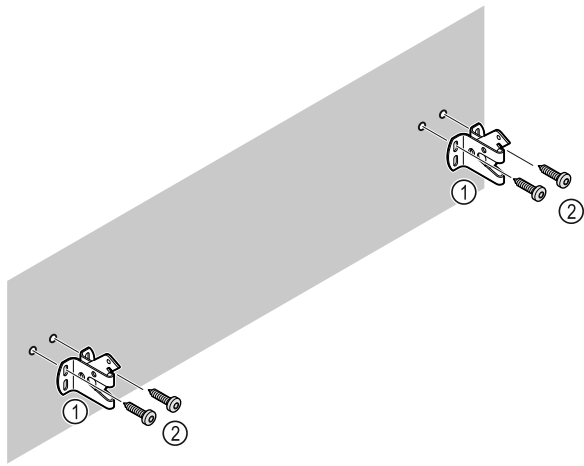

Fig. 52

Use fixing material (e.g. dowels) which is appropriate for the nature of the wall (wood, concrete) and sufficient attachment points .

- ▶ Attach retaining hooks.

## 3.10 Installing appliance



### CAUTION

Risk of injury and damage.

- ▶ Use 2 people to install appliance.



### CAUTION

Risk of injury and damage.

The door can knock against the wall and become damaged as a result. In the case of glass doors, the damaged glass can cause injuries.

- ▶ Protect the door from knocking against the wall. Attach door stopper, e.g. felt stopper, to the wall.

- ▶ Connect all necessary components (e.g. mains cable) to the back of the appliance and route to the side.

### Note

Cables can be damaged.

- ▶ Do not jam the cable when pushing the appliance back.

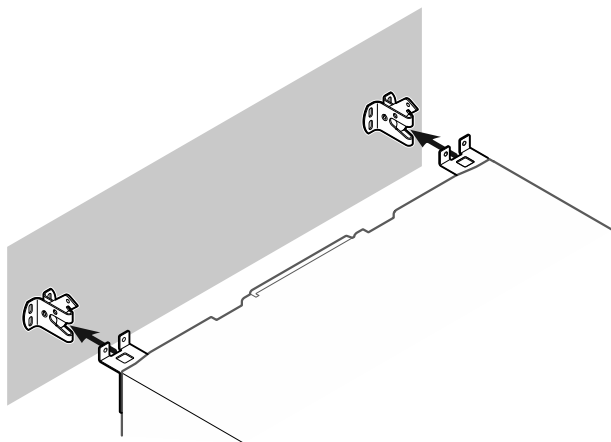

Fig. 53

- ▶ Slide appliance up against the wall so that the retaining parts latch into the securing hooks.
- ▶ The appliance is now secured against tipping.
- ▶ It can be released by folding back the securing hooks.

## 3.11 Setting up the appliance so it is level

### NOTICE

Appliance body is deformed and door does not close.

- ▶ Align appliance horizontally and vertically.
- ▶ Compensate for uneven floors using adjustable feet.



### WARNING

Incorrect height adjustment of the adjustable foot!

Can cause severe or even fatal injury. Incorrect height adjustment can cause the bottom part of the adjustable foot to come loose and the appliance to tip over.

- ▶ Do not unscrew the adjustable foot too far.

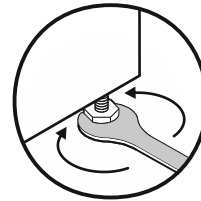

Fig. 54 \*

### Raising appliance:

- ▶ Turn adjustable foot clockwise.

### Lowering appliance:

- ▶ Turn adjustable foot anticlockwise.

## 3.12 Installing multiple appliances

### NOTICE

Risk of damage due to condensation between the side walls.

- ▶ Do not install the appliance directly next to another fridge.
- ▶ Install appliances with a space 3 cm between appliances.
- ▶ Only install multiple appliances up to temperatures of 35 °C and 65% humidity next to one another.
- ▶ At higher levels of humidity, increase space between appliances.

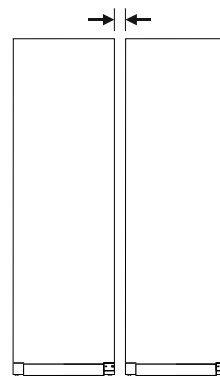

Fig. 55 Side-by-side installation

### Note

A side-by-side kit is available as an accessory via Liebherr Customer Service. (see 10.4 Customer Service)

## 3.13 After installation

- ▶ Peel off the protective films. \*
- ▶ Clean appliance. (see 9.3 Cleaning the appliance)
- ▶ If necessary: Disinfect the appliance.

# Functionality of the Touch & Swipe display

- ▶ Keep the invoice so you have the appliance and dealer information available if needed.

## 3.14 Disposing of packaging



### WARNING

Danger of suffocation due to packing material and plastic film!

- ▶ Do not allow children to play with packing material.

The packaging is made of recyclable materials:

- corrugated board/cardboard
- expanded polystyrene parts
- polythene bags and sheets
- polypropylene straps
- nailed wooden frame with polyethylene panel\*

- ▶ Take the packaging material to an official collecting point.

## 3.15 Connecting the appliance to the power supply



### WARNING

Danger of electric shock and injury due to damaged appliance or damaged mains cable!

Danger of cuts and fatal injuries. If the appliance or the mains cable is damaged during transport, you may be electrocuted. You could also cut yourself on damaged parts of the appliance housing.

- ▶ Check the appliance and the mains cable for damage after transport.
- ▶ Never put the appliance into operation if the appliance or the mains cable are damaged.
- ▶ Contact Customer Service.

You can connect your appliance to the mains using the power cable supplied separately. The mains power cable has an appliance coupler at one end and a mains plug at the other end.

Make sure that the following requirements are fulfilled:

- The appliance and power cable are undamaged.
- The appliance is set up in accordance with the regulations. (see 3.7 Removing transport lock)
- Requirements for the electrical connection are met. (see 3.1 Installation requirements)
- Dimensions for connection in accordance with regulations are known and observed.
- Mains voltage and frequency correspond to the specifications on the type plate.
- The socket is earthed according to the regulations and fused.
- The fuse tripping current is between 10 A and 16 A.
- The socket is easily accessible and is not behind the appliance.

### NOTICE

Danger of damage to incorrect operation!

Damage to the electrical components of the appliance.

- ▶ Only use the supplied mains cable.



### WARNING

Danger of fire due to incorrect connection!

Burns.

Damage to the appliance.

- ▶ Do not use an extension cable.
- ▶ Do not use distributor blocks.

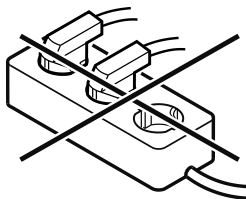

### NOTICE

Danger of damage to incorrect connection!

Damage to the appliance.

- ▶ Do not connect the appliance to a stand-alone inverter, e.g. solar power systems and petrol generators.





- ▶ Connect the mains cable plug to the power supply. Ensure that the plug is tightly in the socket.
- ▶ The standby symbol appears in the display.
- ▶ If no action occurs within 60 seconds: The standby symbol fades or disappears.
- ▶ The appliance is connected. For information regarding first use, see the following section or the operating instructions.

## 4 Functionality of the Touch & Swipe display

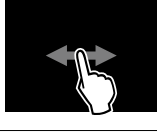

You operate your appliance using the Touch & Swipe display. You select appliance functions in the Touch & Swipe display (hereafter referred to as display) by tapping them. If you do not perform any action on the display for 10 seconds, the display either jumps back to the higher-level menu or directly to the status display.

### 4.1 Navigation and symbol explanation

In the illustrations, different symbols are used to navigate the display. The following table describes these symbols.

Symbol	Description
	<b>Briefly touch the display:</b> Activates/deactivates function. Confirms selection. Opens submenu.
	<b>Touch the display for a specified time (e.g. 3 seconds):</b> Activates/deactivates function or value.
	<b>Swipe left or right:</b> Navigate in the menu.
	<b>Briefly touch the Back symbol:</b> Jumps back one menu level.

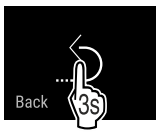
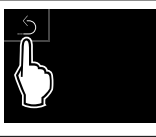
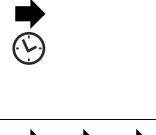
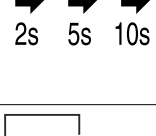
# Functionality of the Touch & Swipe display

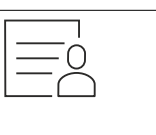
Symbol	Description
	<b>Press and hold the Back symbol for 3 seconds:</b> Jumps back to the status display.
	<b>Briefly touch the Back symbol at the top left:</b> Jumps back one menu level.
	<b>Arrow with clock:</b> It takes more than 10 seconds for the following message to appear in the display.
	<b>Arrow with a time indication:</b> It takes the specified amount of time until the following message appears in the display.
	<b>“Open Settings menu” symbol:</b> Navigates to the Settings menu and opens the settings menu. If necessary: Navigate to the desired function in the Settings menu. (see 4.2.1 Opening the Settings menu)
	<b>“Open Advanced menu” symbol:</b> Navigates to the Advanced menu and opens the advanced menu. If necessary: Navigate to the desired function in the Advanced menu. (see 4.2.2 Opening the expanded menu)
No action for 10 seconds	If you do not perform any action on the display for 10 seconds, the display either jumps back to the higher-level menu or directly to the status display.
Open door and close it again.	If you open the door and immediately close it again, the display jumps directly back to the status display.

Note: Illustrations of the display are shown in the English version.

## 4.2 Menus

The appliance functions are distributed over various menus:

Menu	Description
Main menu	When you switch the appliance on, you are automatically in the main menu. From here you can navigate to the most important appliance functions, to the Settings menu and to the Advanced menu.
 Settings menu	The Settings menu contains additional appliance functions for setting up your appliance.

Menu	Description
 Advanced menu	The advanced menu contains special appliance functions for setting up your appliance. Access to the Advanced menu is protected by the numerical code <b>151</b> .

### 4.2.1 Opening the Settings menu

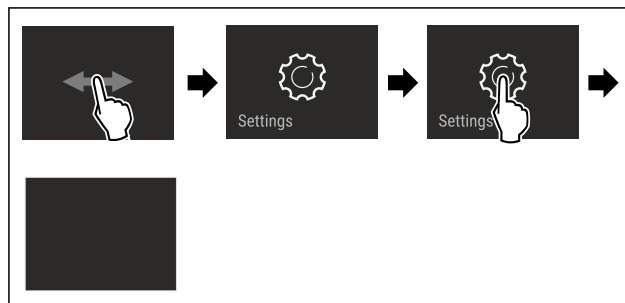

Fig. 56 Example illustration

- ▶ Carry out action steps according to the illustration.
- ▶ Settings menu is open.
- ▶ If necessary: Navigate to the desired function.

### 4.2.2 Opening the expanded menu

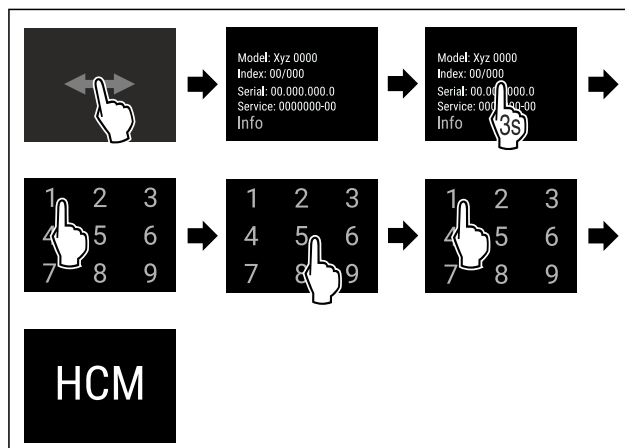

Fig. 57 Access with numerical code 151

- ▶ Carry out action steps according to the illustration.
- ▶ The expanded menu is open.
- ▶ If necessary: Navigate to the desired function.

## 4.3 Sleep mode

If you do not touch the display for 1 minute, the display switches to sleep mode. In sleep mode, the display brightness is dimmed.

### 4.3.1 Ending sleep mode

- ▶ Touch the display briefly with your finger.
- ▶ Sleep mode is ended.

## 5 Putting into operation

### 5.1 Switching on appliance (first use)

Ensure that the following requirements are met:

- Appliance is installed and connected.
- All adhesive strips, adhesive and protective films and transport locks are removed from inside and outside the appliance.



Fig. 58 Example illustration

- ▶ The standby symbol is flashing: Wait until the start process is complete.
- ▶ The display shows the standby symbol.

If the appliance has been supplied with factory settings, the screen language and the date/time first need to be set when using the appliance for the first time.

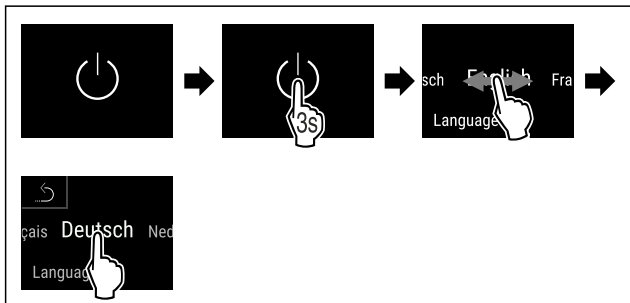

Fig. 59

- ▶ Carry out action steps according to the illustration.
- ▶ Language is set.

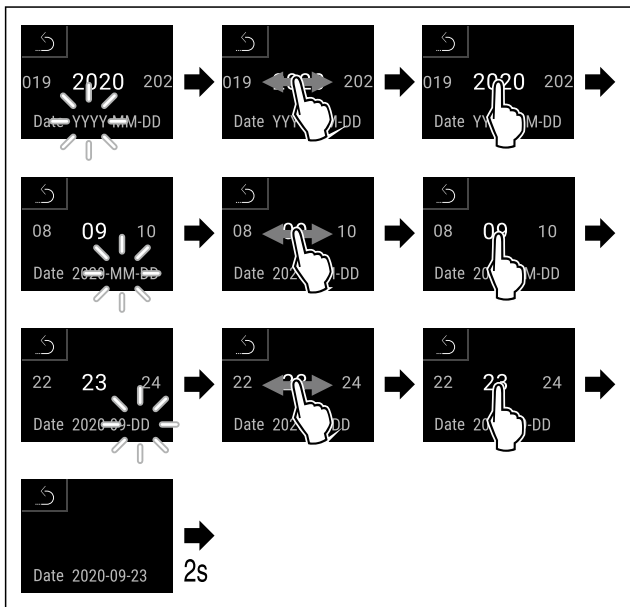

Fig. 60

- ▶ Carry out action steps according to the illustration.
- ▶ Date is set.

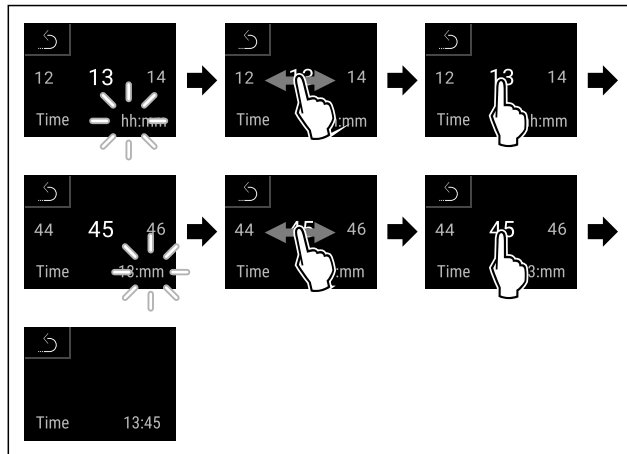

Fig. 61

- ▶ Carry out action steps according to the illustration.
- ▶ Time is set.

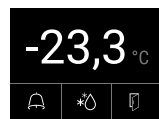

Fig. 62 Status display

- ▶ The appliance is ready for operation once the temperature appears in the display.
- ▶ The temperature display flashes until the set temperature is reached.

## 6 Storage

### 6.1 Information regarding storage

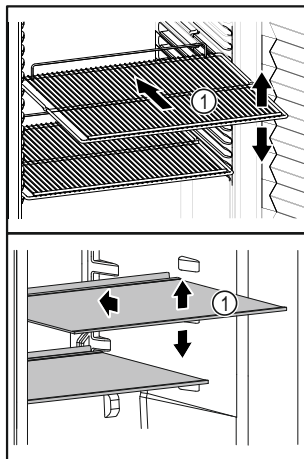

Fig. 63 Example illustration

When stocking observe the following:

- ❑ If storage surfaces Fig. 63 (1) are movable, adjust them according to height.
- ❑ Observe maximum load weight. (see 10.1 Technical specifications)
- ❑ Do not load appliance until storage temperature has been reached (maintain cold chain).
- ❑ Refrigerated goods must not touch the rear wall.
- ❑ Refrigerated items do not protrude beyond the shelves.
- ❑ Keep liquids in closed containers.
- ❑ Leave space when storing items for refrigeration to ensure good air circulation.
- ❑ Do not stack refrigerated products above the indicated height. \*

# Controls

This is important for free air circulation and even temperature distribution in the interior.\*

## 7 Controls

### 7.1 Control and display elements

The display provides a quick overview of the current appliance status, the temperature setting, the status of functions and settings as well as alarm and error messages.

Operation takes place directly on the Touch & Swipe display by swiping and touching.

Functions can be activated or deactivated and setting values can be changed.



Fig. 64 Touch & Swipe display

(1) Status display

#### 7.1.1 Status display



Fig. 65 Status display

(1) Actual temperature      (3) Defrosting status  
(2) Alarm status              (4) Door opening status

The status display is the output display.

It displays the temperature in the middle and three symbols in the lower area. The status display can show other display symbols.

Navigation to the functions takes place from the status display.

#### 7.1.2 Display symbols

Display symbols provide information about the status of the appliance.

Symbol	Appliance status
	<b>Standby symbol</b> Appliance is switched off.
	<b>Standby symbol (flashing)</b> Appliance is starting up.

Symbol	Appliance status
	<b>Temperature (flashing)</b> Target temperature not yet reached. Appliance cooling to temperature set.
	<b>D in the display</b> The appliance is in demo mode.
	<b>Maintenance indicator (yellow)</b> The set time interval has expired.
	<b>Data memory full (yellow)</b> The data memory (999 hours) is full. The oldest data will be overwritten from now on.
	<b>Memory full alarm (yellow)</b> The alarm memory is full. Delete individual alarms or the entire memory.
	<b>Error symbol (red)</b> Appliance is in error state.
	<b>Background (blue)</b> Active setting or active function
	<b>Bar (increasing)</b> Press for 3 seconds to activate the setting.
	<b>Bar (decreasing)</b> Press for 3 seconds to deactivate the setting.

Symbols on the status display

The additional symbols on the bottom of the status display enable fast access to alarm information and details regarding the appliance status.

Symbol	Appliance status
	<b>Alarm symbol (grey)</b> Alarm archive is empty. Pressing briefly opens the alarm archive.
	<b>Alarm symbol (white)</b> There are confirmed alarms in the alarm archive. Pressing briefly opens the alarm archive.
	<b>Alarm symbol (red)</b> There are still unconfirmed alarms in the alarm archive. Pressing briefly opens the alarm archive.
	<b>Alarm symbol (red, flashing)</b> There is an active alarm in the archive. Pressing briefly opens the alarm archive.

Symbol	Appliance status
	<b>Defrosting symbol (grey)</b> No active defrosting process.
	<b>Defrosting symbol (white, flashing)</b> Defrosting is active. Tapping briefly opens the appliance defrosting function. (see 7.2.19 Defrosting )
	<b>Defrosting symbol (white)</b> Automatic defrosting is active. The function cannot be cancelled.
	<b>Door symbol (grey)</b> The door is closed.
	<b>Door symbol (white)</b> The door is open.
	<b>Door symbol (red, flashing)</b> The door has been open for a prolonged period of time; the relevant warning message has been acknowledged. The symbol flashes until the door is closed.

Additional symbols on the status display

## 7.1.3 Acoustic signals

A signal sounds in the following cases:

- If a function or a value is confirmed.
- If a function or a value can either not be activated or not deactivated.
- As soon as an error occurs.
- If there is an alarm message.

The alarms can be switched on and off in the customer menu.

## 7.2 Appliance functions

### 7.2.1 Notes on the appliance functions

The appliance functions are set at the factory so that your appliance is fully functional.

Before you alter, activate or deactivate the device functions, make sure that the following requirements are met:

- You have read and understood the descriptions of how the display works. (see 4 Functionality of the Touch & Swipe display)
- You have familiarised yourself with the operating and display elements of your appliance. (see 7.1 Control and display elements)

### 7.2.2 Switching appliance on and off



This function makes it possible to switch the entire appliance on and off.

#### Switching on appliance

**If demo mode is not activated:**

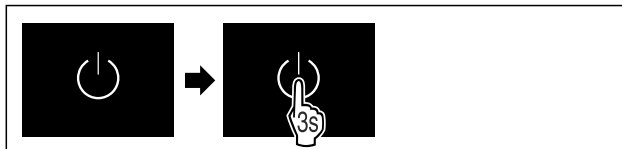

Fig. 66

- ▶ Carry out action steps according to the illustration.

**If demo mode is activated:**

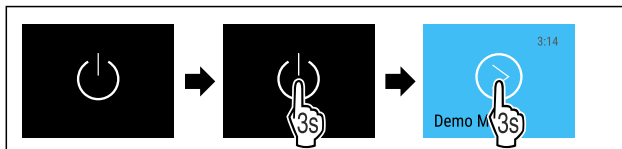

Fig. 67

- ▶ Carry out action steps according to the illustration.

#### Note

Deactivate demo mode before the countdown has finished.

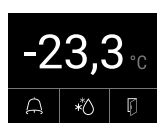

Fig. 68 Status display

- ▶ The temperature appears in the display.

### Switching off appliance



Fig. 69

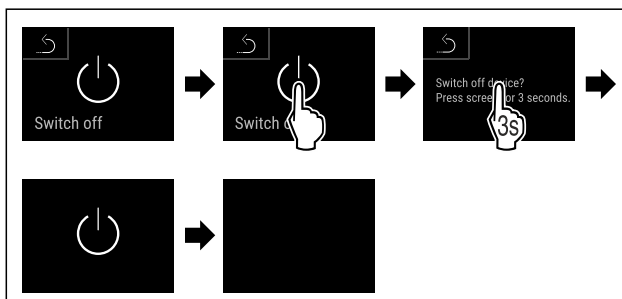

Fig. 70

- ▶ Carry out action steps according to the illustration.
- ▶ Standby symbol is shown in the display.
- ▶ The display switches off automatically after around 10 minutes.

### 7.2.3 Temperature



The temperature depends on the following factors:

- How often the door is opened
- How long the door is open for
- The room temperature of the installation site
- The type, temperature and amount of food

#### Note

The temperature may differ from the temperature displayed in some areas of the interior.

At the correct temperature, frozen food will keep for longer. This avoids disposing of food unnecessarily.

# Controls

## Setting temperature

The following steps describe how to increase the temperature, e.g. from -33.3 °C to -31.8 °C.

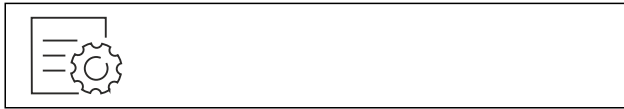

Fig. 71

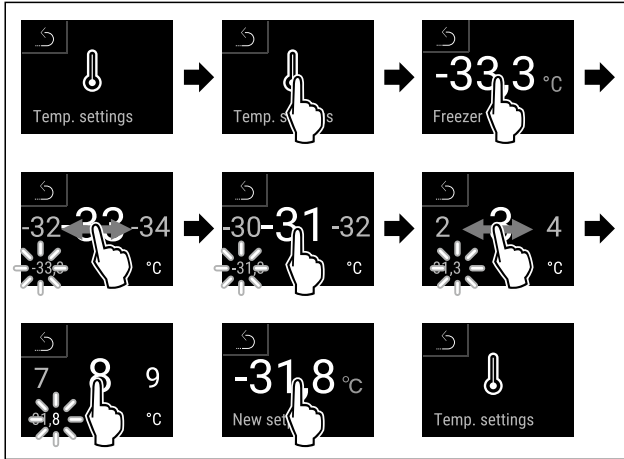

Fig. 72

- ▶ Carry out action steps according to the illustration.
- ▶ Temperature is set.

## 7.2.4 Temperature recording



The appliance displays the minimum and maximum temperatures of the interior via this function. The recording of these temperatures starts automatically after the appliance is switched on; they are recorded at one minute intervals. A note indicating that the data memory is full is displayed after 999 hours (approx. 40 days). The temperature recording should then be reset.

### Note

The entire temperature history as well as alarm and service messages are also recorded independently of this function. This data can be exported and backed up on a USB storage medium. (see 7.2.20 Data download (data backup) )

If there is an additional product sensor installed on the appliance, there is the option of selecting this sensor to display the minimum and maximum temperatures. (see 7.2.21 Sensor calibration )

### Note

The temperature recording should be reset once **after reaching the set temperature** when the appliance is commissioned. (see Resetting temperature recording) This ensures that the value for the maximum temperature is a meaningful value.

## Displaying temperature recording

The temperature recording displays the length of the recording and the minimum and maximum temperatures measured during this period of time.



Fig. 73



Fig. 74

- ▶ Status screen with the temperature recordings is displayed.

## Resetting temperature recording

The displayed minimum and maximum temperatures can be reset at any time. This deletes the displayed values and the recording interval starts again.



Fig. 75

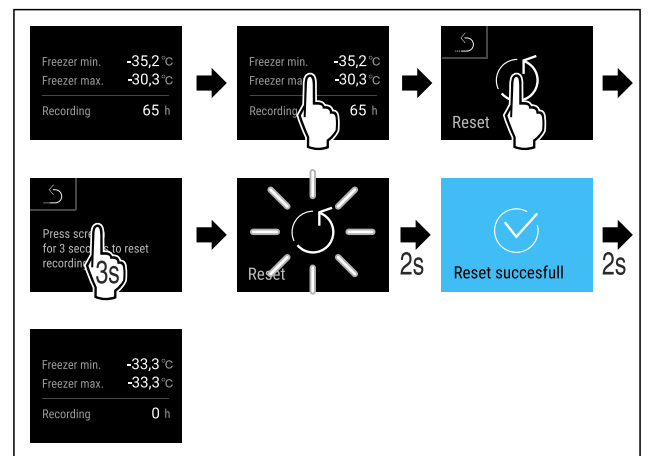

Fig. 76

- ▶ Carry out action steps according to the illustration.
- ▶ Temperature recording is reset.

## 7.2.5 Settings menu access protection



This function enables the settings menu access protection via a four-digit PIN code.

Application:

- Prevent settings and functions being changed unintentionally.
- Prevent appliance being switched off unintentionally.
- Prevent temperature being set unintentionally.

### Note

- ▶ In the following examples, the factory-set PIN code: **1 1 1 1** is used.

## Activating the settings menu access protection



Fig. 77

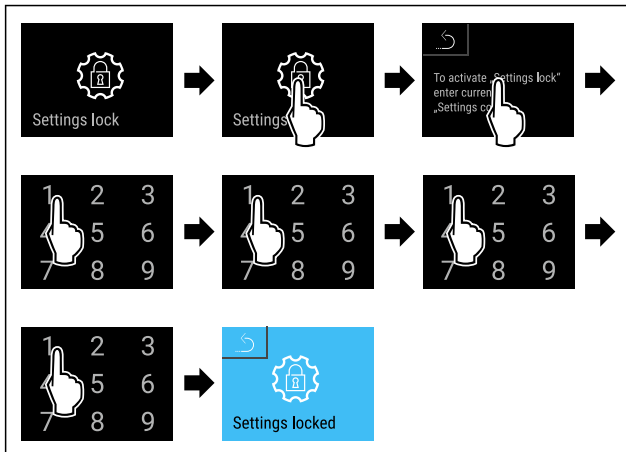

Fig. 78

- ▶ Carry out action steps according to the illustration.
- ▶ Settings menu access protection is activated.

### Changing the access protection PIN code for the settings menu

(see 7.2.6 Access codes)

#### Deactivating the settings menu access protection

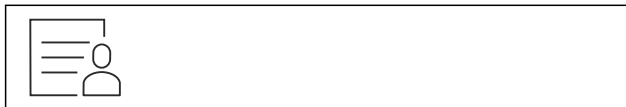

Fig. 79

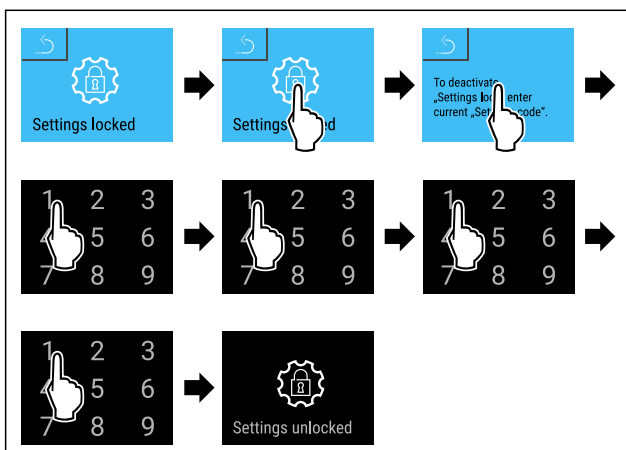

Fig. 80

- ▶ Carry out action steps according to the illustration.
- ▶ Settings menu access protection is deactivated.

#### Opening protected settings menu

If the settings menu access protection is active, you must enter the PIN code in order to be able to open the settings menu. As soon as you exit the settings menu, the access protection re-activates automatically.

- ▶ Swipe left or right until corresponding function is displayed.

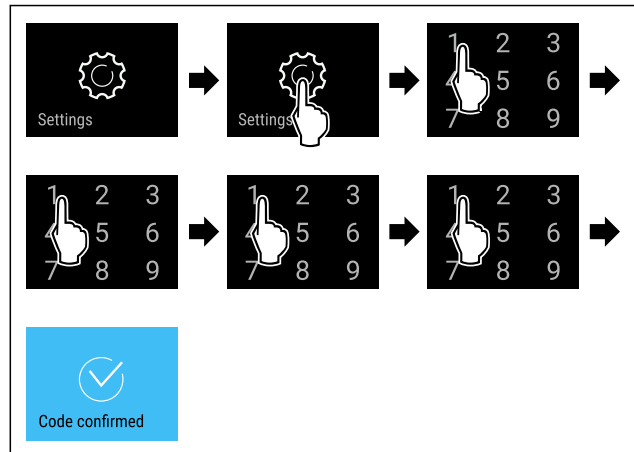

Fig. 81

- ▶ Carry out action steps according to the illustration.
- ▶ PIN code is correct: settings menu opens.

## 7.2.6 Access codes

Access codes are required for some functions. You can only use the following functions after entering the appropriate access code:

- Settings menu



#### Access code for the settings menu

This function allows the access code for the settings menu to be changed or reset.

#### Changing the access code for the settings menu

The access code can be changed in three steps:

- Enter old access code.
- Enter new access code.
- Confirm new access code.

#### Note

In the following example, you change the factory-set access code **1 1 1 1** to the new access code **2 3 4 5**.

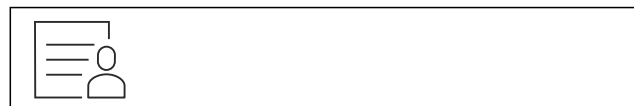

Fig. 82

#### Access protection for the settings menu must be active. (see 7.2.5 Settings menu access protection )

- ▶ Swipe left or right until corresponding function is displayed.

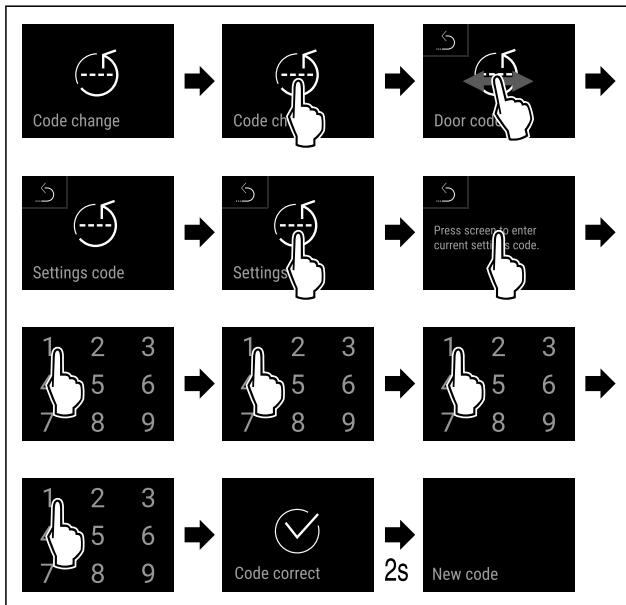

Fig. 83

- ▶ Carry out action steps according to the illustration.
- ▶ Entering the old access code is successful.

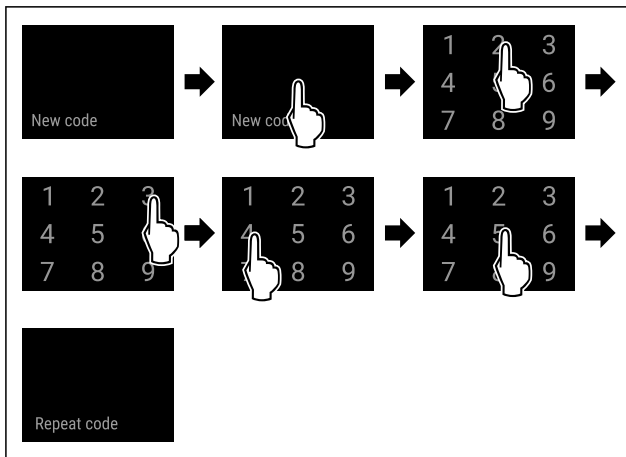

Fig. 84

- ▶ Carry out action steps according to the illustration.
- ▶ The new access code has been successfully entered.

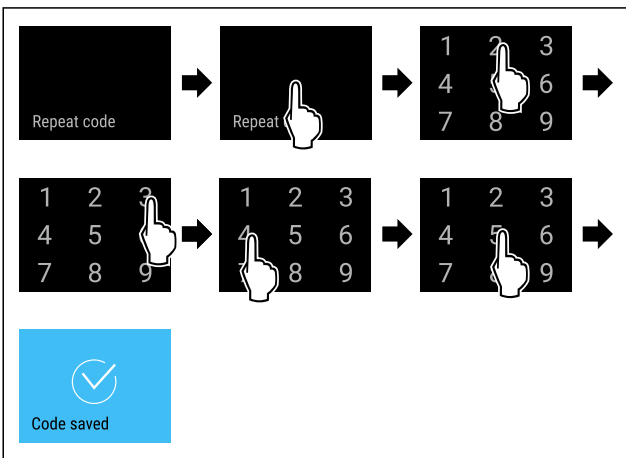

Fig. 85

- ▶ Carry out action steps according to the illustration.
- ▶ Confirmation of the new access code is successful.
- ▶ The access code for the settings menu has been changed.

## Resetting the access code for the settings menu

If you no longer know the access code for the settings menu, you can reset it.

- ▶ Reset appliance to factory settings (see 7.2.28 Resetting to factory settings ).
- ▶ The appliance has been reset to its original settings.
- ▶ The factory-set access code is: **1 1 1 1**

## 7.2.7 Maintenance interval reminder



Setting for the time interval after which a maintenance reminder is issued.

The following values can be set:

- 7 days
- 14 days
- 30 days
- 60 days
- 90 days
- 180 days
- 360 days
- 720 days
- 1080 days
- Off

### Setting maintenance interval reminder

The following steps describe how the maintenance interval is set.



Fig. 86

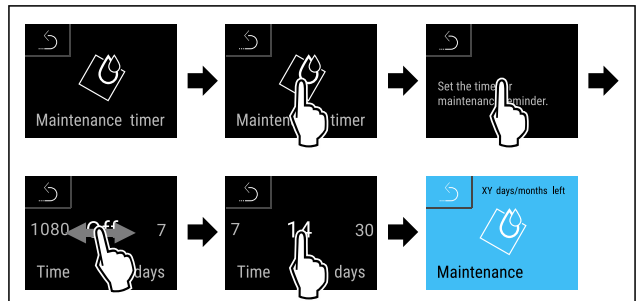

Fig. 87

- ▶ Carry out action steps according to the illustration.
- ▶ The time interval, after which the maintenance reminder is issued, is set.
- ▶ The remaining time is displayed.

## 7.2.8 Language



This setting allows the display language to be set.

### Setting language



Fig. 88

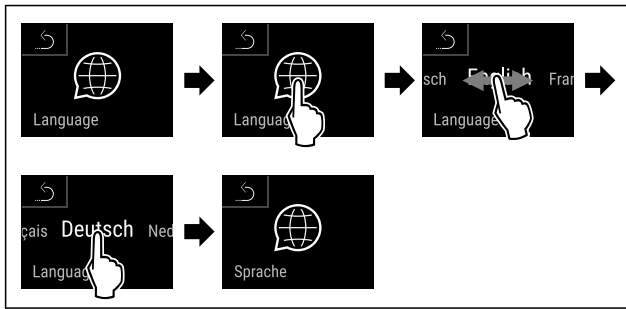

Fig. 89

- ▶ Carry out action steps according to the illustration.
- ▶ The selected language is set.



## 7.2.9 Date and time

This setting makes it possible to set the date and time.

### Setting date and time



Fig. 90



Fig. 91

- ▶ Carry out action steps according to the illustration.

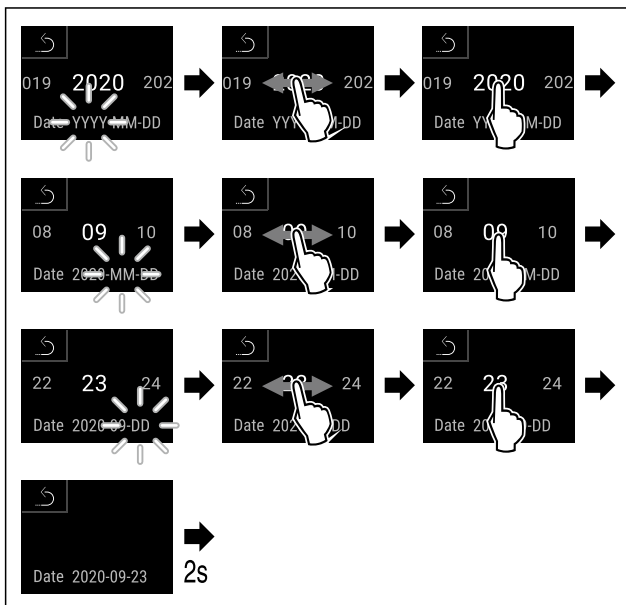

Fig. 92

- ▶ Carry out action steps according to the illustration.
- ▶ Date has been set.

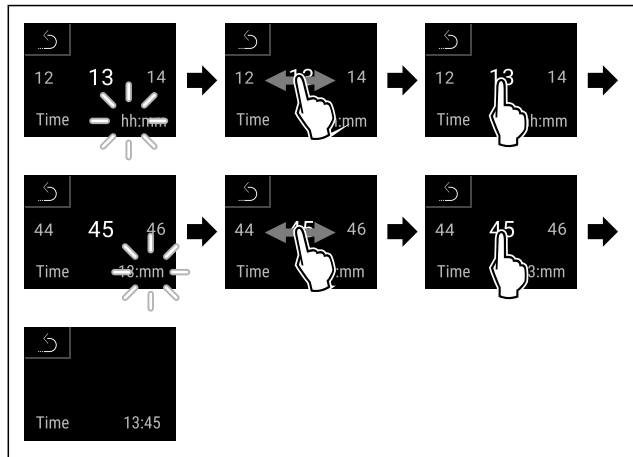

Fig. 93

- ▶ Carry out action steps according to the illustration.
- ▶ Time has been set.



## 7.2.10 Temperature unit

Use this function to set the temperature unit. You can set degrees Celsius or degrees Fahrenheit as the temperature unit.

### Setting the temperature unit



Fig. 94

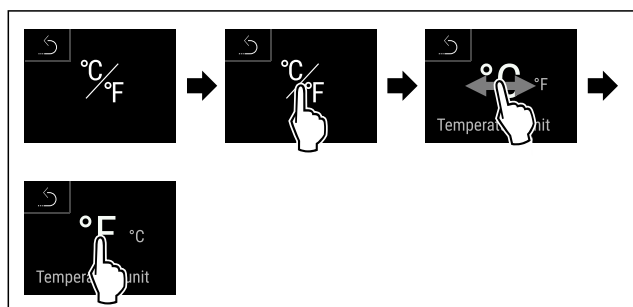
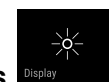

Fig. 96 Example illustration: Switch from degrees Celsius to degrees Fahrenheit.

- ▶ Carry out action steps according to the illustration.
- ▶ The temperature unit is set.



## 7.2.11 Display brightness

Use this function to set the display brightness in stages.

You can select the following brightness levels:

- 40 %
- 60 %
- 80 %
- 100 % (pre-setting)

### Setting the brightness



Fig. 97

# Controls

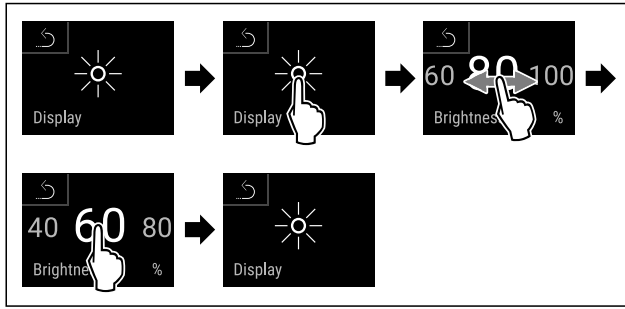

Fig. 98 Example illustration: Switch from 80 % to 60 %.

- ▶ Carry out action steps according to the illustration.
- ▷ The brightness is set.



## 7.2.12 Alarm tone

This function enables all alarm sounds, such as door alarms, to be switched on and off.

### Activating the alarm tone

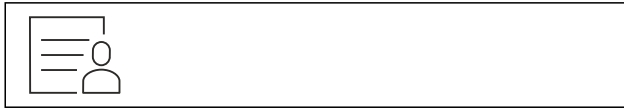

Fig. 99

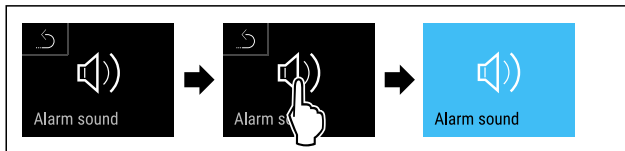

Fig. 100

- ▶ Carry out action steps according to the illustration.
- ▷ The alarm tone is activated.

### Deactivating the alarm tone



Fig. 101



Fig. 102

- ▶ Carry out action steps according to the illustration.
- ▷ The alarm tone is deactivated.



## 7.2.13 Key tone

This function makes it possible to switch all button sounds, confirmation sounds, and the startup sound on and off.

### Activating the key tone

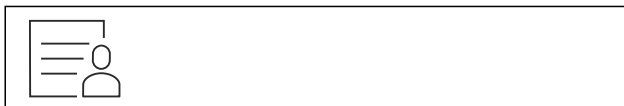

Fig. 103

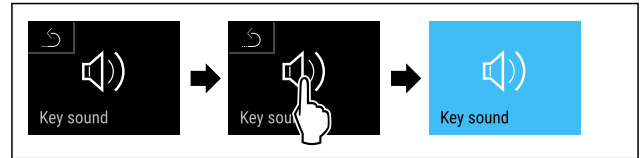

Fig. 104

- ▶ Carry out action steps according to the illustration.
- ▷ The key tone is activated.

### Deactivating the key tone



Fig. 105

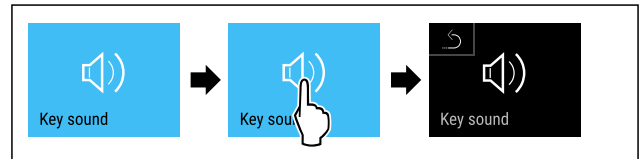

Fig. 106

- ▶ Carry out action steps according to the illustration.
- ▷ The key tone is deactivated.



## 7.2.14 WiFi connection

### Note

Liebherr SmartMonitoring Dashboard is not available in all countries. Check availability via the QR code by entering your model.

### Note

Use of the Liebherr SmartMonitoring Dashboard at <https://smartmonitoring.liebherr.com> requires installation of a SmartModule and a commercial MyLiebherr account. When commissioning online you can register using the login data you have, or register again and create a company account.

This setting establishes a wireless connection between the appliance and the internet. The connection is controlled via the SmartModule. The appliance can be integrated via the browser-based [Liebherr SmartMonitoring Dashboard](#) and advanced options as well as customised methods relating to control, administration and monitoring can be used.

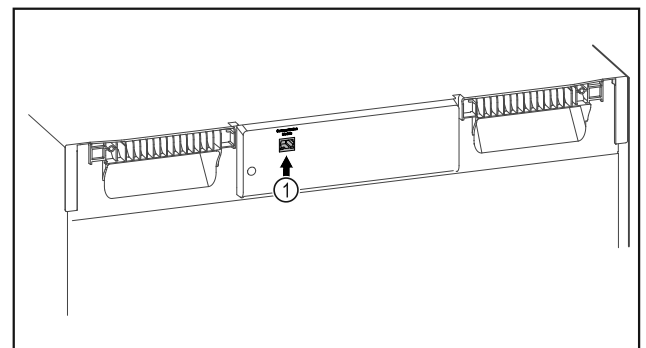

Fig. 107

Make sure that the following requirements are fulfilled:

- SmartModule Fig. 107 (1) is in use.

## Establishing connection

You commission and set up your SmartModule online via the [Liebherr SmartMonitoring Dashboard](#) on your web-enabled device.

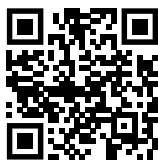

Fig. 108

- ▶ Open [Liebherr SmartMonitoring Dashboard](#). (see Fig. 108)
- On the refrigerator or freezer:



Fig. 109

## Note

The settings menu access protection is activated. (see 7.2.5 Settings menu access protection )

- ▶ Enter the chosen PIN code. The settings menu opens.



Fig. 110

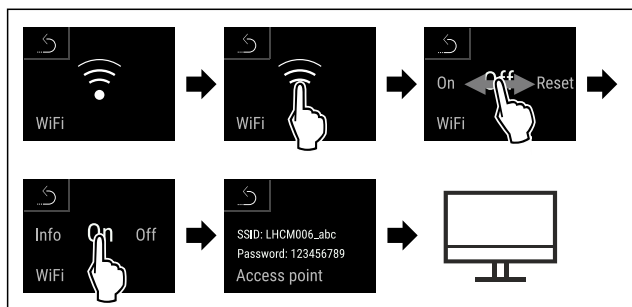

Fig. 111

- ▶ Carry out action steps according to the illustration.
- ▶ Continue the set-up procedure on your web-enabled device: [Liebherr SmartMonitoring Dashboard](#)

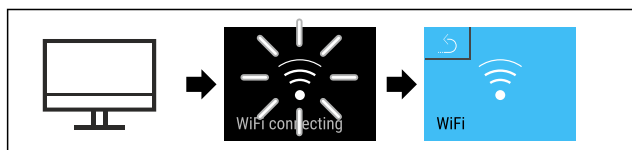

Fig. 112

- ▶ Carry out action steps according to the illustration.
- ▶ Connection is established: WiFi connecting appears. The symbol flashes.
- ▶ Follow the [Liebherr SmartMonitoring Dashboard](#) instructions.
- ▶ Connection is established.

## Disconnecting



Fig. 113

## Note

The settings menu access protection is activated. (see 7.2.5 Settings menu access protection )

- ▶ Enter the chosen PIN code. The settings menu opens.



Fig. 114

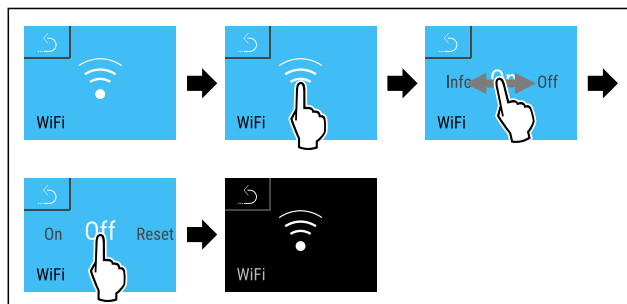

Fig. 115

- ▶ Carry out action steps according to the illustration.
- ▶ There is no connection.

## Resetting connection



Fig. 116

## Note

The settings menu access protection is activated. (see 7.2.5 Settings menu access protection )

- ▶ Enter the chosen PIN code. The settings menu opens.



Fig. 117

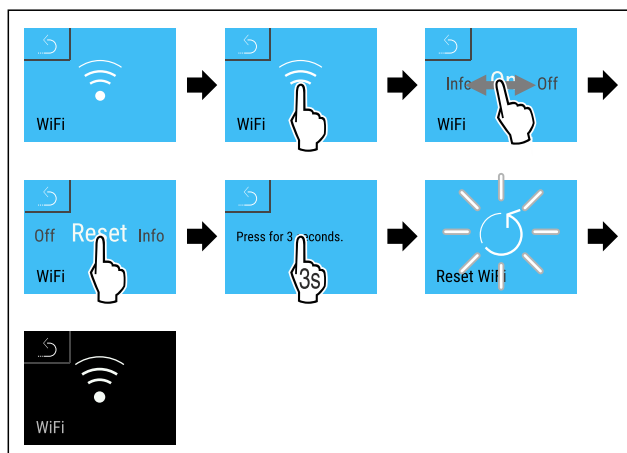

Fig. 118

- ▶ Carry out action steps according to the illustration.
- ▶ The WiFi settings are restored to the factory settings.

## 7.2.15 LAN connection



### Note

Liebherr SmartMonitoring Dashboard is not available in all countries. Check availability via the QR code by entering your model.

### Note

Use of the Liebherr SmartMonitoring Dashboard at <https://smartmonitoring.liebherr.com> requires installation of a SmartModule and a commercial MyLiebherr account. When commissioning online you can register using the login data you have, or register again and create a company account.

This setting establishes a wired connection between the appliance and the internet. The connection is controlled via the SmartModule. The appliance can be integrated via the browser-based [Liebherr SmartMonitoring Dashboard](#) and advanced options as well as customised methods relating to control, administration and monitoring can be used.

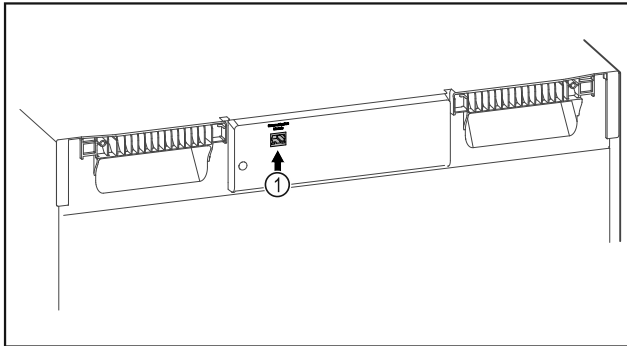

Fig. 119

Make sure that the following requirements are fulfilled:

- SmartModule Fig. 119 (1) is in use.
- A network cable is connected.
- The network is connected to the internet.

### Establishing connection

You commission and set up your SmartModule online via the [Liebherr SmartMonitoring Dashboard](#) on your web-enabled device.



Fig. 120

- ▶ Open [Liebherr SmartMonitoring Dashboard](#). (see Fig. 120)
- On the refrigerator or freezer:



Fig. 121

### Note

The settings menu access protection is activated. (see 7.2.5 Settings menu access protection )

- ▶ Enter the chosen PIN code. The settings menu opens.

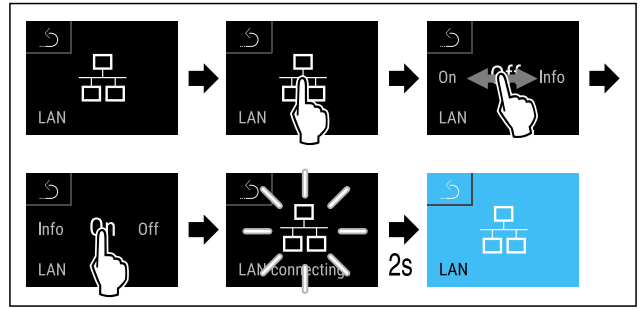

Fig. 122

- ▶ Carry out action steps according to the illustration.
- ▶ Connection is established: LAN connecting appears. The symbol flashes.
- ▶ Follow the [Liebherr SmartMonitoring Dashboard](#) instructions.
- ▶ Connection is established.

### Disconnecting



Fig. 123

### Note

The settings menu access protection is activated. (see 7.2.5 Settings menu access protection )

- ▶ Enter the chosen PIN code. The settings menu opens.

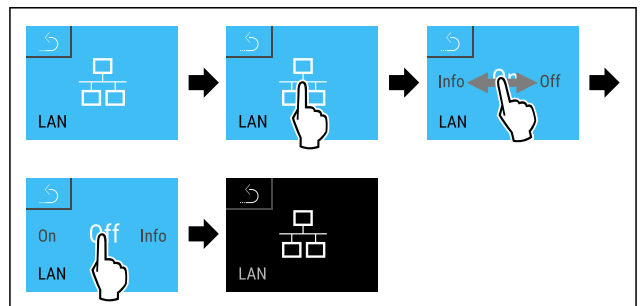

Fig. 124

- ▶ Carry out action steps according to the illustration.
- ▶ There is no connection.

## 7.2.16 Device information

Use this function to indicate the model name, index, serial number and service number of your device. You will need the device information when you contact customer service. (see 10.4 Customer Service)

This function also opens the Advanced menu. (see 4 Functionality of the Touch & Swipe display)

### Indicating the device information



Fig. 125

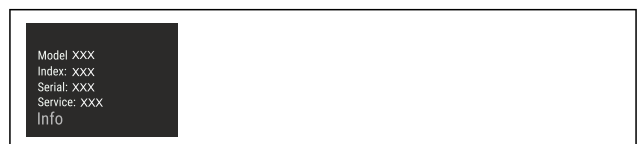
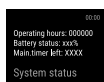

Fig. 126

- ▶ Carry out action steps according to the illustration.
- ▶ Display indicates device information.



## 7.2.17 Operating hours

The display shows the appliance operating hours.

### Displaying operating hours



Fig. 127

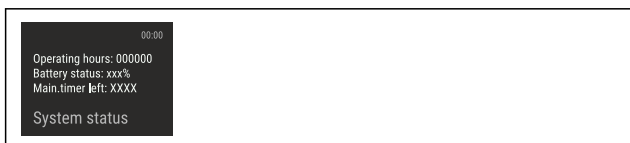

Fig. 128

- ▶ The operating hours appear.



## 7.2.18 Software

Use this function to indicate the software version of your device.

### Indicating the software version



Fig. 129

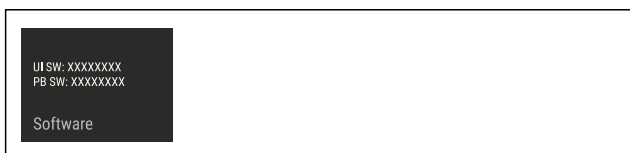

Fig. 130

- ▶ Carry out action steps according to the illustration.
- ▶ Display indicates software version.



## 7.2.19 Defrosting

The appliance defrosts automatically in normal operation.

Application:

- If there is heavy icing in the interior, the automatic defrosting function can be started manually.

### Starting automatic defrosting manually



Fig. 131

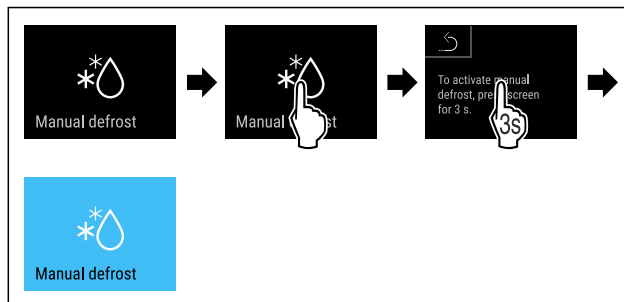

Fig. 132

- ▶ Carry out action steps according to the illustration.
- ▶ Automatic defrosting is started. When the defrosting process is complete, the appliance automatically switches back to normal operation.

### Note

If there is still ice in the interior after the automatic defrosting has been started several times, defrost the appliance manually. (see 9.2 Defrosting appliance)

### Cancelling a manually started defrosting



Fig. 133

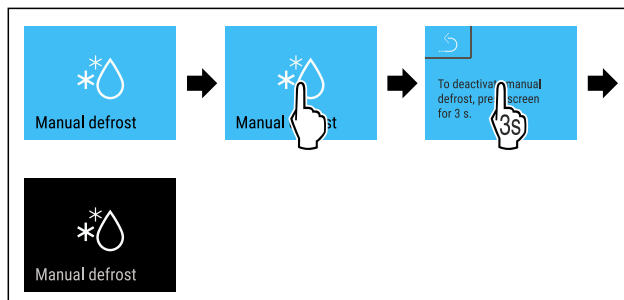

Fig. 134

- ▶ Carry out action steps according to the illustration.
- ▶ Manually started defrosting is cancelled. The appliance automatically switches back to normal operation.



### Defrosting info

This setting adjusts the display during an automatic defrosting.

Display	Description
Def 1	The temperature display is not being updated. It shows the last temperature before the automatic defrosting process started.
Def 2	"Automatic defrosting" icon is indicated on the status display. The temperature display is continuously updated and displays the actual temperature.

# Controls

Display	Description	
<b>Def 3</b>	With software version PW SW lower than <b>TOD 8-800:</b>	The temperature display is not being updated. It shows the last temperature before the automatic defrosting process started.
	With software version PW SW equal to or higher than <b>TOD 8-800:</b>	The temperature display is continuously updated and displays the actual temperature.
<b>Def 4</b>	With software version PW SW lower than <b>TOD 8-800:</b>	The temperature display is not being updated. It shows the last temperature before the automatic defrosting process started.
	With software version PW SW equal to or higher than <b>TOD 8-800:</b>	“Automatic defrosting” notice is indicated on the status display. The temperature display is not being updated. It shows the last temperature before the automatic defrosting process started.



Display of the “automatic defrosting” in the status display



Here you can see the software version installed on your appliance PW SW: (see 7.2.18 Software )

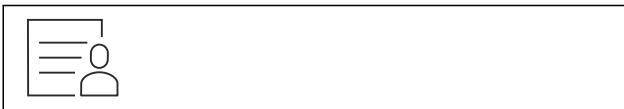

Fig. 135

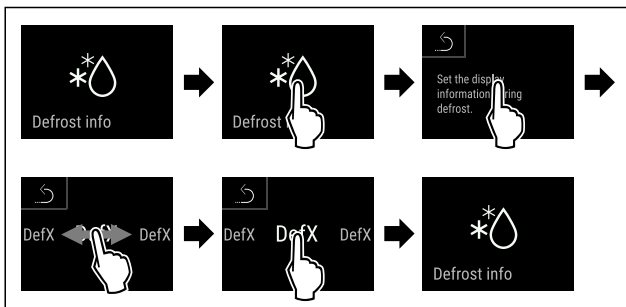

Fig. 136

- ▶ Carry out action steps according to the illustration.
- ▷ The desired display variant is selected.

## 7.2.20 Data download (data backup)



Use this function to activate the appliance's data backup on a USB stick. The appliance records the entire temperature curve of different sensors, as well as alarm and warning messages automatically. Recording starts automatically after you have switched the appliance on. The appliance records the data from the last 5 years at an interval of one minute.

If you activate data backup, you can select which data you want to save to the USB stick:

- Temperature curve file (Temperature\_Log\_000)
- Event log (Event\_Log\_000)

- Service information (Service\_Info)
- All

The data backup covers the entire recording duration. The saved text files are unencrypted and have the file extension „.log“.

Further information on the saved text files:	(see 10.3 Data recording)
--	---------------------------

### Activating data backup on the USB stick

Make sure that the following requirements are fulfilled:

- The USB stick is FAT32 formatted.
- The USB stick is connected. The appliance cannot detect USB hard disks.



Fig. 137

### Note

Do not remove the USB stick during the data backup.

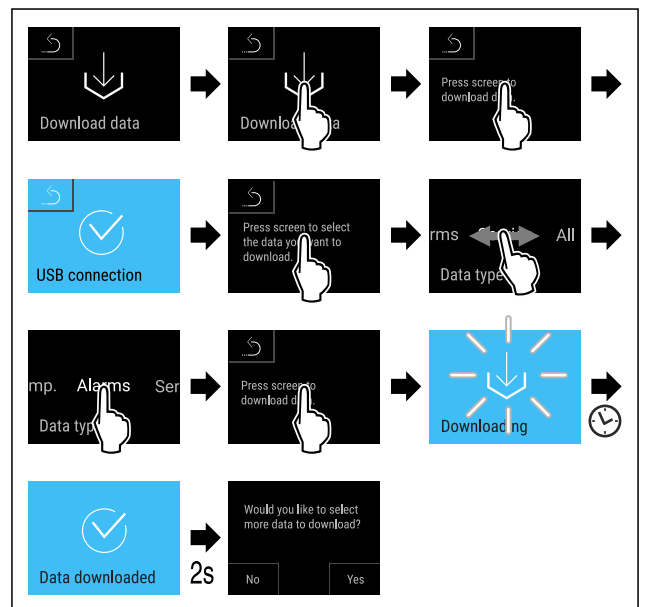

Fig. 138

- ▶ Carry out action steps according to the illustration.
- ▷ Data backup on the USB stick successful: You can select further data and back it up to the USB stick.

## 7.2.21 Sensor calibration



You can use sensor calibration to compensate for differences between the set temperature and the actual existing temperature. To do this, use calibrated measuring equipment to determine the actual existing temperature.

Setting range for C sensor (control sensor): +/- 3 Kelvin in 0.1 Kelvin increments.

Setting range for P sensor (product sensor): +/- 9.9 Kelvin in 0.1 Kelvin increments

### Calibrating sensor



Fig. 139

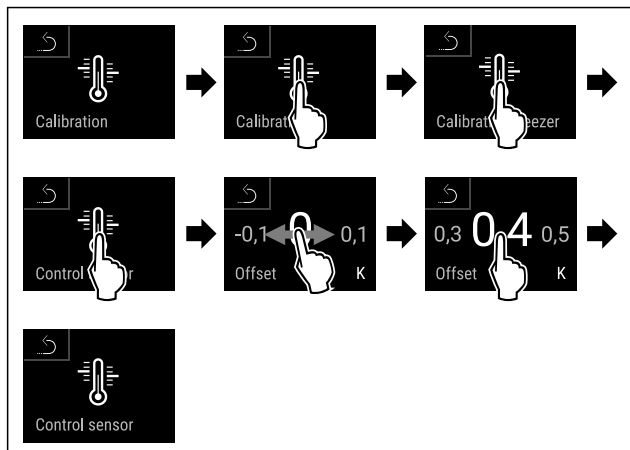

Fig. 140

- ▶ Carry out action steps according to the illustration.
- ▶ C sensor has been calibrated.

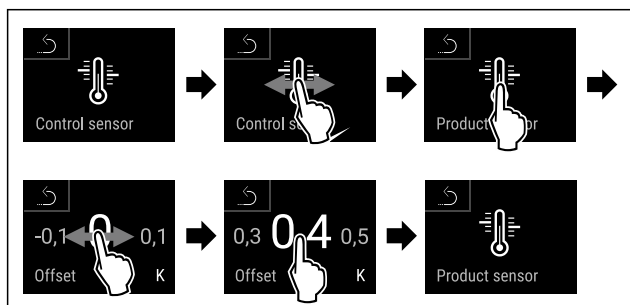

Fig. 141

- ▶ Carry out action steps according to the illustration.
- ▶ P sensor has been calibrated.
- ▶ Sensor calibration has been completed.

## Note

The calibrated temperature is indicated on the display within two hours.

## 7.2.22 Temperature alarm



Use this function to set the temperature alarm. You set the upper and lower temperature limits with a differential offset to the indoor temperature currently set. The temperature alarm is triggered as soon as the indoor temperature leaves the set temperature range and any set delay time has elapsed.

Example		Differential value to be set
Current indoor temperature	5 °C	
Lower temperature limit	2 °C	-3 °C
Upper temperature limit	8 °C	+3 °C

The following values can be set:

- Differential value for lower temperature limit in 0.1 °C steps
- Differential value for upper temperature limit in 0.1 °C steps
- Alarm delay time from 0 to 60 minutes (setting "0" means no temperature alarm delay.)
- Alarm repetition frequency from 0 to 30 minutes (setting "0" means no alarm repetition after confirming the alarm.)

## Setting temperature alarm

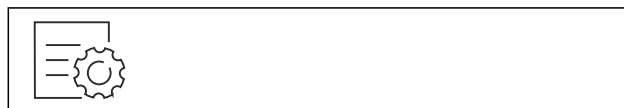

Fig. 142

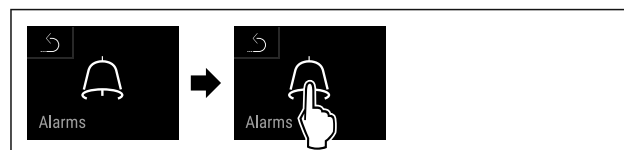

Fig. 143

- ▶ Carry out action steps according to the illustration.



Fig. 144

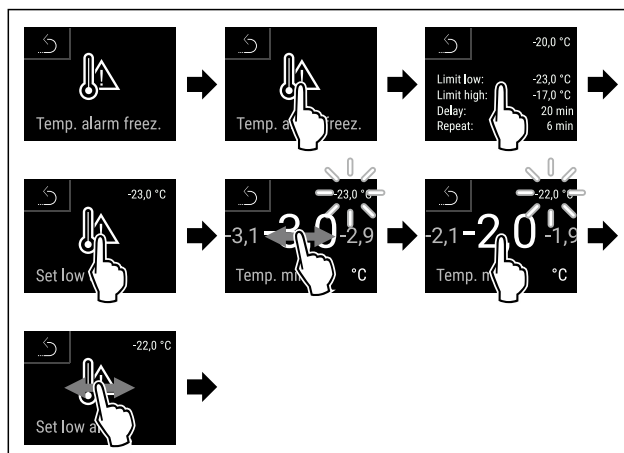

Fig. 145 Example of setting the lower temperature limit based on a set appliance temperature of -20 °C.

- ▶ Carry out action steps according to the illustration.
- ▶ Lower temperature limit has been set.

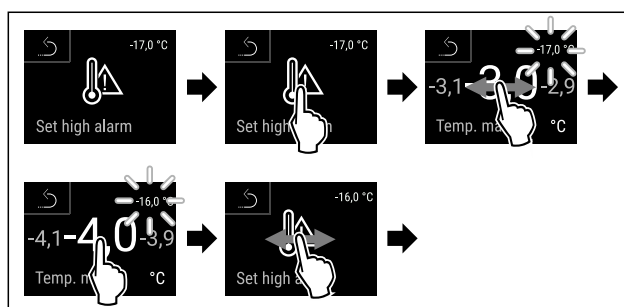

Fig. 146 Example of setting the upper temperature limit based on a set appliance temperature of -20 °C.

- ▶ Carry out action steps according to the illustration.
- ▶ Upper temperature limit has been set.

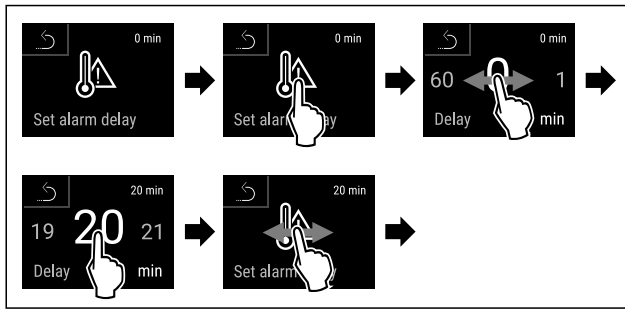

Fig. 147

- ▶ Carry out action steps according to the illustration.
- ▷ Alarm delay time has been set.

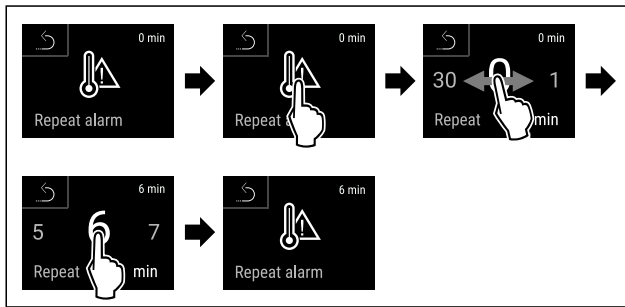

Fig. 148

- ▶ Carry out action steps according to the illustration.
- ▷ Alarm repetition interval has been set.
- ▷ Temperature alarm has been set.

### Displaying set temperature alarm values



Fig. 149

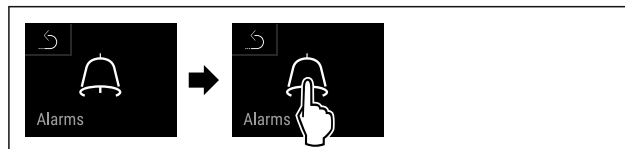

Fig. 150

- ▶ Carry out action steps according to the illustration.



Fig. 151

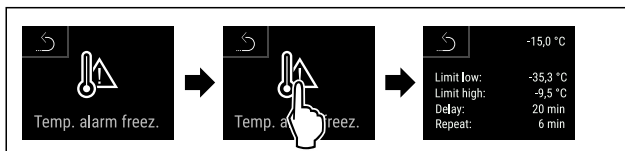

Fig. 152

- ▶ Carry out action steps according to the illustration.
- ▷ Set temperature alarm values are displayed.

## 7.2.23 Door alarm



Use this function to activate or deactivate the door alarm. The door alarm sounds if the door is open for too long. The door alarm is activated on delivery. You can set how long the door may be open before the door alarm sounds.

The following values can be set:

- 15 seconds
- 30 seconds
- 60 seconds
- 90 seconds
- 120 seconds
- 150 seconds
- 180 seconds
- Off

### Setting the door alarm

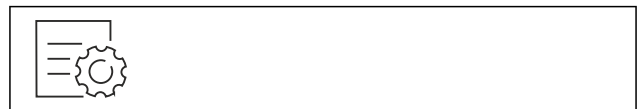

Fig. 153

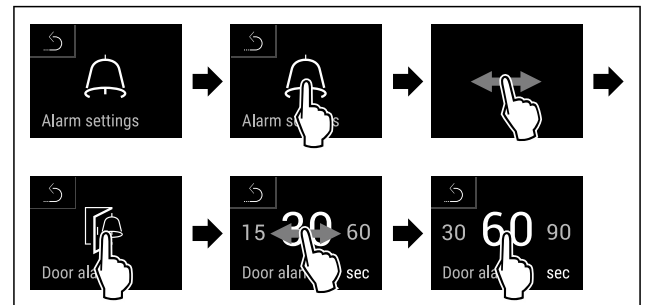

Fig. 155 Example illustration: Switch door alarm from 30 seconds to 60 seconds.

- ▶ Carry out action steps according to the illustration.
- ▷ The door alarm is set.

### Deactivating the door alarm

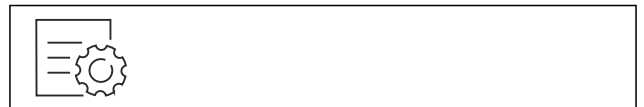

Fig. 156

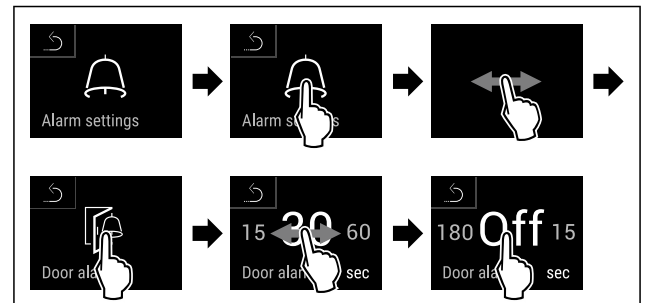

Fig. 157

- ▶ Carry out action steps according to the illustration.
- ▷ The door alarm is deactivated.

## 7.2.24 Alarm simulation



You can use this function to simulate a temperature alarm in the appliance, e.g. to check whether a safety device triggers

correctly. The safety device is connected to the potential-free alarm output. (see 8.4 Interfaces)

## Starting the alarm simulation



Fig. 158



Fig. 159

- ▶ Carry out action steps according to the illustration.



Fig. 160

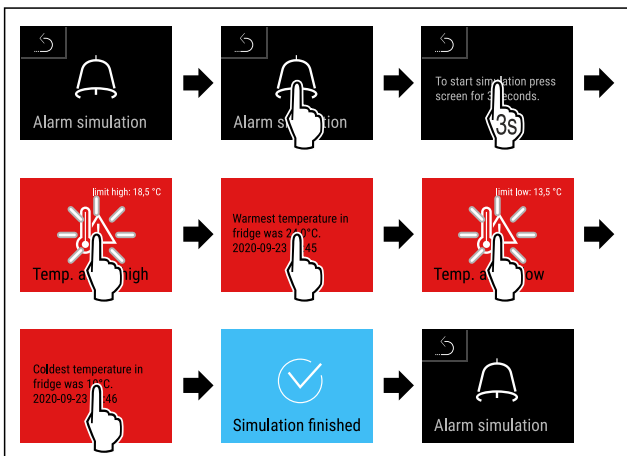

Fig. 161

- ▶ Carry out action steps according to the illustration.
- ▶ The simulation has been performed.
- ▶ Connected safety devices should have triggered.

## 7.2.25 Alarm log



This setting makes it possible to query and delete the last 10 alarms that have occurred on the device.

The following is displayed:

- Current date and time
- Active alarms (red).
- Past alarms, which have not yet been queried, are shown as **unconfirmed (red)**. Confirmation is given by swiping to the next error.
- Alarms, which have been queried, are shown as **confirmed**.
- Deletion of all alarms (including active and unconfirmed alarms).

## Displaying alarm log and deleting an alarm



Fig. 162

-or-

- ▶ Via the display symbol at the bottom edge of the status display.

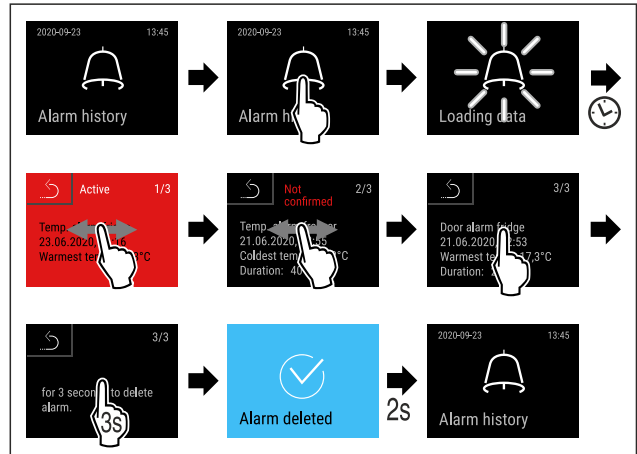

Fig. 163

- ▶ Carry out action steps according to the illustration.
- ▶ The querying and deletion of an alarm has been performed.

## Displaying alarm log and deleting all alarms



Fig. 164

-or-

- ▶ Via the display symbol at the bottom edge of the status display.

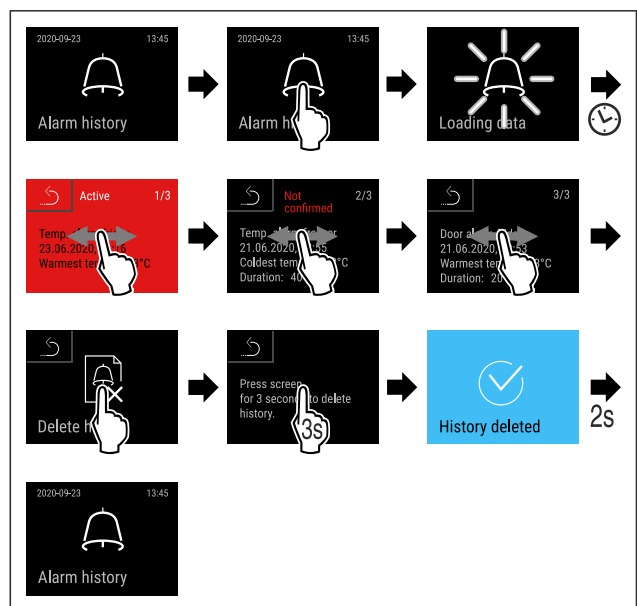

Fig. 165

- ▶ Carry out action steps according to the illustration.
- ▶ The querying and deletion of all alarms has been performed.



## 7.2.26 Alarm forwarding

You can use this function to forward one or several alarms to an external alarm receiver. The alarm receiver is connected to the potential-free alarm output on the appliance. (see 8.4 Interfaces)

You can select the following settings:

- Alarm type:
  - Door alarm
  - Temperature alarm
  - Door alarm and temperature alarm
  - All
- Confirm:
  - **Yes:** The alarm is confirmed on the appliance and the external, connected receiver.
  - **No:** The alarm is confirmed on the appliance and remains active on the receiver until the fault is rectified.
- Refresh (only visible if you select “Yes” when confirming):
  - **Yes:** Alarm repeats.
    - Temperature alarm** depending on the set time (see 7.2.22 Temperature alarm ) (If you set the alarm delay time to “0”, there is no alarm repetition on the alarm relay.)
    - Door alarm** after 1 or 4 minutes\* (see 7.2.23 Door alarm )
  - **No:** The alarm is confirmed permanently.

### Activating alarm forwarding



Fig. 166

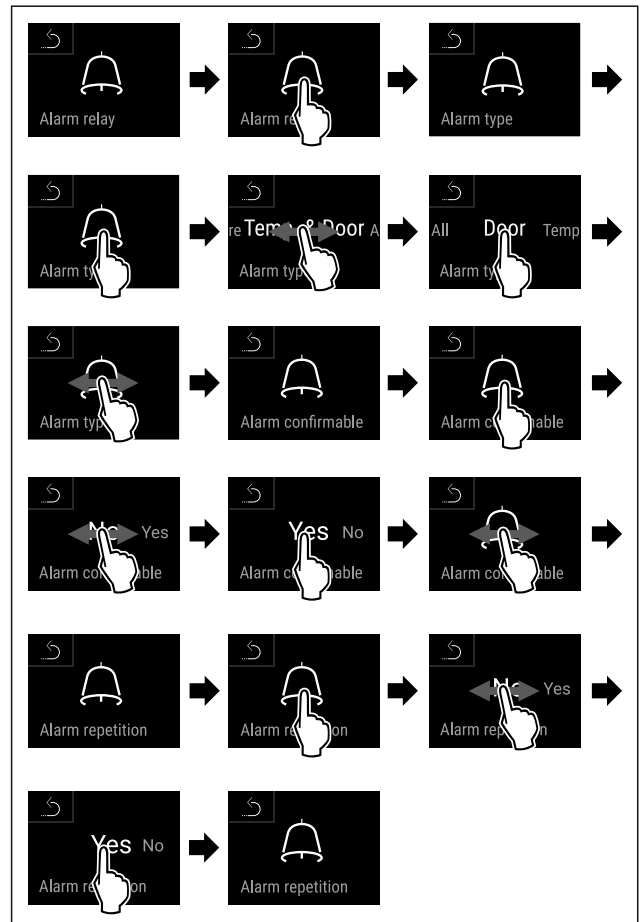
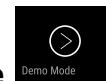

Fig. 167

- ▶ Carry out action steps according to the illustration.
- ▶ Alarm forwarding is set.



## 7.2.27 Demo mode

Demo mode is a special feature for dealers who want to demonstrate appliance features. If you activate demo mode, all refrigeration functions are deactivated.

If you switch on your appliance and a “D” appears on the status display, demo mode is already activated.

If you activate and then deactivate demo mode, the appliance will be reset to factory defaults. (see 7.2.28 Resetting to factory settings )

### Activating demo mode

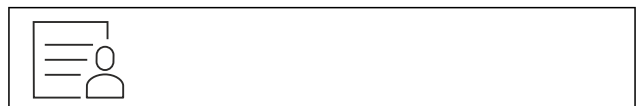

Fig. 168

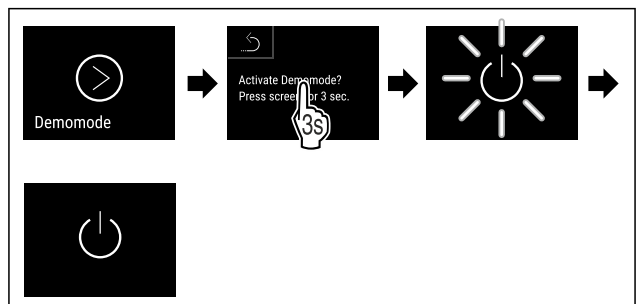

Fig. 169

- ▶ Carry out action steps according to the illustration.

- ▷ Demo mode is activated.
- ▷ Appliance is switched off.
- ▶ Switch on the appliance. (see 5.1 Switching on appliance (first use))
- ▷ “D” appears in the status display.

## Deactivating demo mode



Fig. 170

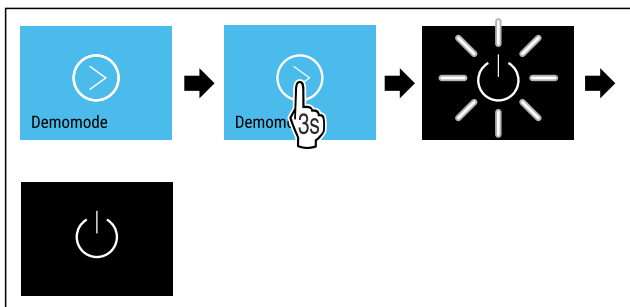

Fig. 171

- ▶ Carry out action steps according to the illustration.
- ▷ Demo mode is deactivated.
- ▷ Appliance is switched off.
- ▶ Switch on the appliance. (see 5.1 Switching on appliance (first use))
- ▷ Appliance is reset to factory settings.

## 7.2.28 Resetting to factory settings



Use this function to reset all settings to factory defaults. All settings you have made so far are reset to their original settings.

## Performing a reset



Fig. 172

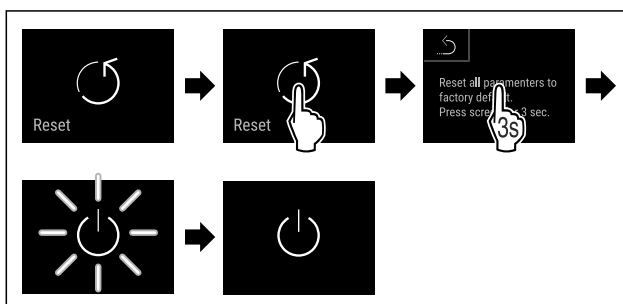

Fig. 173

- ▶ Carry out action steps according to the illustration.
- ▷ Device is reset.
- ▷ Device is switched off.

### Note

To reset to factory settings in battery mode: Restart is only possible with mains voltage.

- ▶ Restart the device. (see 5.1 Switching on appliance (first use))





## 7.3 Message

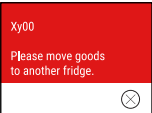

### 7.3.1 Warnings

Warnings are issued by means of an acoustic signal and visually via a symbol on the display. The signal gets louder until the warning is acknowledged.

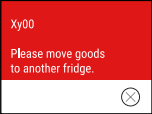
Message (red)	Cause	Remedy
 <b>Door open</b>	This message appears if the door is open for too long.	Close the door. Tap briefly. Alarm is stopped. <b>Note</b> The time until the message appears can be set. (see 7.2.23 Door alarm )
 <b>Temperature alarm</b>	This message appears if the temperature does not match the set temperature. Reasons for differences in temperature can be: Warm produce for cooling has been placed inside. Too much warm air has got in while you were sorting out the freezer or removing items. The power was cut off for a prolonged period.	Tap briefly. Information about errors and appliance status are displayed. Tap briefly. Warmest/coldest temperature, date and time are displayed. Tap briefly. The status screen is displayed. The current temperature and the alarm symbol flash red until the set temperature is reached. Check the quality of the refrigerated goods.

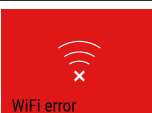
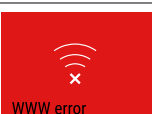

# Controls

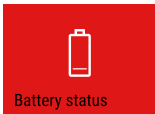
Message (red)	Cause	Remedy
 <p>Device failure</p> <p><b>Error</b></p>	<p>The appliance is faulty, there is an appliance error or a component of the appliance has a fault.</p>	<p>Store the cooled produce elsewhere.</p> <p>Tap briefly.</p> <p>The error code (e.g. BT021) is displayed.</p> <p>Tap briefly.</p> <p>A further error code is displayed if there is one</p> <p><b>or</b></p> <p>Status screen is displayed with flashing error symbol.</p> <p>Swiping or tapping the display will show the error code(s) again.</p> <p>Make a note of error code(s) and contact Customer Service. (see 10.4 Customer Service)</p>  
	<p>The message indicates unscheduled defrosting behaviour. For example, the evaporator could ice up to an unusual extent due to prolonged door openings and the defrosting time may no longer be sufficient.</p>	<p>Tap briefly.</p> <p><b>DEFR.MAX</b> is displayed.</p> <p>Tap briefly.</p> <p>Status screen is displayed with flashing error symbol.</p> <p>Swiping or tapping the display will show the message again.</p> <p>Store the cooled produce elsewhere and defrost the appliance by hand. Alternatively, defrosting can be started manually. (see 7.2.19 Defrosting )</p> <p>The flashing error symbol disappears after a long tap. If the message is displayed repeatedly and the causes listed do not apply, contact customer service. (see 10.4 Customer Service)</p>  
 <p>Power failure</p> <p><b>Power cut</b></p>	<p>The message appears following an interruption to the electricity supply.</p> <p>The operating panel continues running in battery mode. All functions remain active except for refrigeration and lighting.</p>	<p>Tap briefly.</p> <p>Battery's state of charge, information about errors and appliance status are displayed</p> <p>Tap briefly.</p> <p>The warmest temperature and the period of power interruptions are displayed.</p> <p>Tap briefly.</p> <p>The status screen is displayed.</p> <p>The current temperature and the alarm symbol flash red until the set temperature is reached.</p> <p>Check the quality of the refrigerated goods.</p>
 <p>WiFi error</p> <p><b>WiFi error</b></p>	<p>Wi-Fi connection is interrupted.</p>	<p>Check connection.</p> <p>Press briefly.</p> <p>Alarm is stopped.</p>
 <p>WWW error</p> <p><b>WWW error, WiFi</b></p>	<p>This message appears if there is no internet connection via WiFi.</p>	<p>Check connection.</p> <p>Press briefly.</p> <p>Alarm is stopped.</p>

Message (red)	Cause	Remedy
 <p><b>LAN error</b></p>	LAN connection is interrupted.	Check connection and network cable. Press briefly. Alarm is stopped.
 <p><b>WWW error, LAN</b></p>	This message appears if there is no internet connection via LAN.	Check connection. Press briefly. Alarm is stopped.
 <p><b>Battery error</b></p>	Low appliance battery level (max. 20% remaining).	Reconnect the appliance to a power supply and check whether the battery charge level has increased after 12 hours. Otherwise contact Customer Service (see 10.4 Customer Service) or replace the battery. (see 9.4 Replacing appliance battery) Press briefly. Alarm is stopped.

## 7.3.2 Reminders

Reminders appear when you are being asked to do something. They are issued by means of an acoustic signal and visually via a symbol on the display. Acknowledge the message by pressing the confirmation button.

Message (yellow)	Cause	Remedy
 <p><b>Maintenance reminder</b></p>	The message appears when the timer for the set maintenance interval has expired.	Press briefly. Reminder is closed. <b>Note</b> The maintenance interval can be set (see 7.2.7 Maintenance interval reminder).
 <p><b>Recording reminder</b></p>	The message appears when the temperature recording memory (999 hours) is full.	Press briefly. Reminder is closed. The oldest data is overwritten. <b>Note</b> The temperature recording can be reset. (see 7.2.4 Temperature recording)
 <p><b>Alarm log</b></p>	The message appears if there are more than 10 unconfirmed alarm messages.	Press briefly. Check messages. Reminder is closed.

## 8 Features

### 8.1 Safety lock

The lock in the appliance door is equipped with a safety mechanism.

#### 8.1.1 Locking appliance

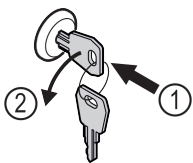

Fig. 174 Example illustration

- ▶ Insert key.
- ▶ Turn key anticlockwise by 90°.

▶ The appliance is locked.

#### 8.1.2 Unlocking appliance

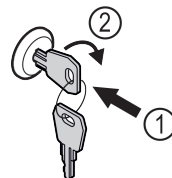

Fig. 175 Example illustration

- ▶ Insert key Fig. 175 (1).
- ▶ Turn key clockwise by 90° Fig. 175 (2).
- ▶ The appliance is unlocked.

# Features

## 8.2 Sensors

The appliance can be equipped with the following sensors for temperature monitoring:

- C sensor
- P sensor

### 8.2.1 C sensor (control sensor)

The C sensor is permanently installed and regulates the interior temperature of the appliance. You can calibrate the C sensor if necessary. (see 7.2.21 Sensor calibration )

### 8.2.2 P sensor (product sensor)

You can position the P sensor in any location in the interior, in order to record and monitor the temperature in this location specifically. If the set temperature is exceeded in this location, the sensor triggers an alarm. You can calibrate the P sensor if necessary. (see 7.2.21 Sensor calibration )

#### Note

You can obtain accessories from customer service (see 10.4 Customer Service) or from specialised dealers via the dealer search on our service page on the Internet:

[home.liebherr.com](http://home.liebherr.com)

## 8.3 Sensor info



This function makes it possible to choose between C sensor or P sensor.

Make sure that the following requirement is met:

- P sensor is connected to the appliance. (see 8.4 Interfaces)

### 8.3.1 Selecting C sensor



Fig. 176

- ▶ Swipe left or right until corresponding function is displayed.

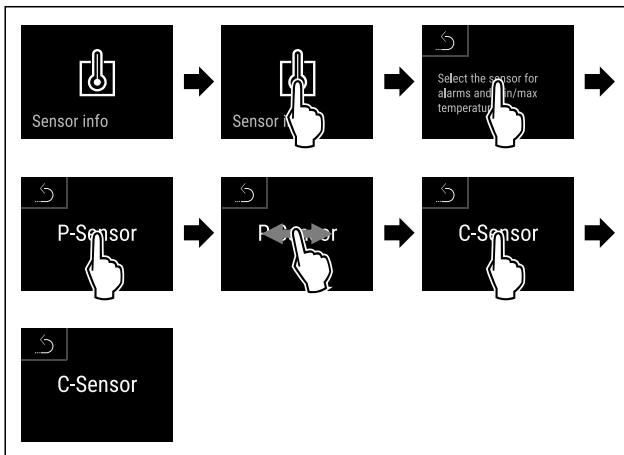

Fig. 177

- ▶ Carry out action steps according to the illustration.
- ▶ C sensor has been selected.

### 8.3.2 Selecting P sensor



Fig. 178

- ▶ Swipe left or right until corresponding function is displayed.

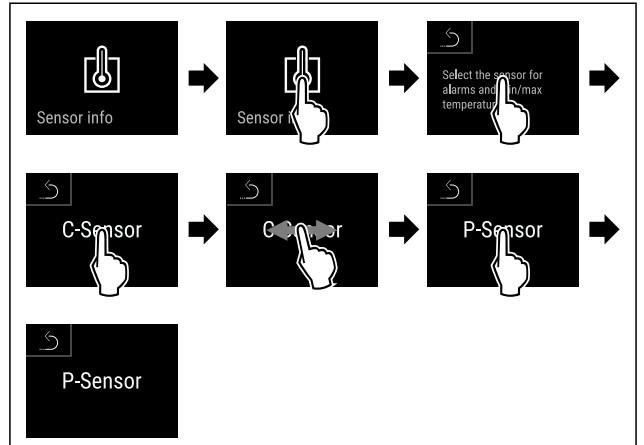

Fig. 179

- ▶ Carry out action steps according to the illustration.
- ▶ P sensor has been selected.

## 8.4 Interfaces

There are various connection options on the back of the appliance.

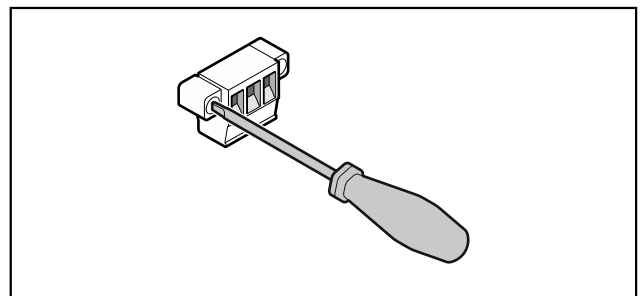

Fig. 180

#### Note

Screws secure the plugs. To enable disconnection of the plugs, loosen the screws on the left and right.

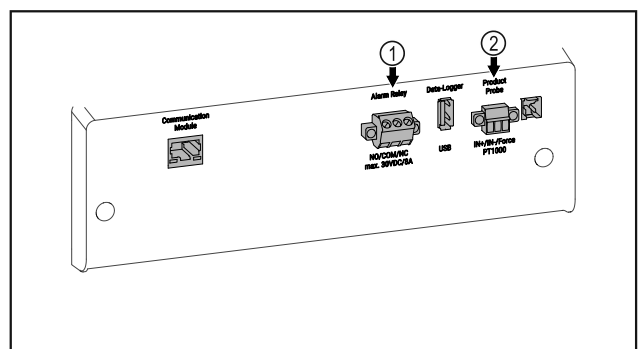

Fig. 181

(1) Potential-free alarm

(2) Connection for P sensor output

## 8.4.1 Potential-free alarm output



### WARNING

Risk of injury due to electric shock!

- ▶ The appliance may only be connected to an external alarm device by trained specialist personnel.

These three contacts can be used to connect a visual or an acoustic alarm device. The connection is designed for a maximum of **30 V (DC) - 8 A** from a safety low voltage source SELV (**minimum current 150 mA**).

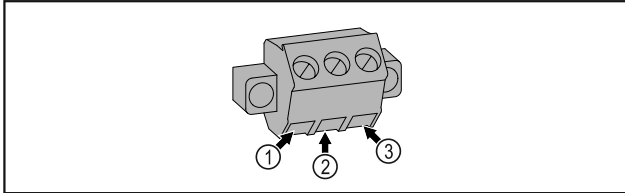

Fig. 182

- (1)** NO (normally open)  
Connection for indicator lamp, which is active in normal operation or when the appliance is switched off.
- (2)** COM (common)  
External voltage source
- (3)** NC (normally closed)  
Connection for alarm lamp or audible alarms, which is active when an alarm is triggered or there is a lack of power supply.

## 8.4.2 Connection for P sensor

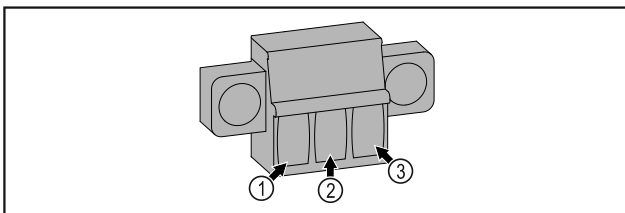

Fig. 183

- (1)** IN+ (measuring line +)
- (2)** IN- (common return line -)
- (3)** FORCE (supply +)

## 9 Maintenance

### 9.1 Maintenance schedule

Maintenance work is to be performed at regular intervals to ensure proper appliance function.



### CAUTION

Danger of injury and damage due to unprofessional maintenance work!

Personal injury and material damage.

- ▶ Maintenance work may only be performed by trained specialist personnel.



### WARNING

Short-circuit hazard due to live parts!

Electric shock or damage to the electronics.

- ▶ **Switch off the appliance.**
- ▶ Pull out mains plug or switch off fuse.

### Note

A maintenance reminder function can be activated. (see 7.2.7 Maintenance interval reminder )

### Note

We recommend creating a maintenance log in which all work (repairs, checks) performed is documented.

### Note

Liebherr recommends yearly maintenance. For an individual offer, please contact Customer Service (see 10.4 Customer Service) .

Component	Activity	Maintenance interval
Sheet metal parts	Check for damage and corrosion. Replace damaged parts: (see 10.4 Customer Service)	Yearly
Door, hinges	Check alignment (see 3.6 Aligning the door) , ease of movement, and tight fit.	Yearly
Lock, door handle *	Check for ease of movement and tight fit.	Yearly
Door seal	Check for damage, wear, and tight fit. A replacement door seal is available via Customer Service (see 10.4 Customer Service) .	Yearly
Sensor	Calibrate sensor. (see 7.2.21 Sensor calibration )	Yearly
Sensor feedthrough	Check that the sealing compound is intact.	Yearly
Battery	Replace appliance battery. A replacement battery is available from customer service. (see 9.4 Replacing appliance battery)	5 to 10 years
Surfaces	Cleaning (see 9.3 Cleaning the appliance)	Recommendation: monthly or as required/specified at installation location

# Maintenance

Component	Activity	Maintenance interval
Surfaces	<p>Disinfection</p> <p>Liebherr has tested the following disinfectants:            Dismozon pur 1 % Lösung (Bode Chemie), Suma Quicksan (Diversey), Incidin Extra N (Ecolab Healthcare), Acrylan (Antiseptica chem.-pharm. Produkte), Buraton 10 F (Schülke und Mayr), Frankocid N (Franken Chemie), Apesin DSR 50 (Tana), Nüscosept Spray (Dr. Nüsken), Melsept SF (B. Braun Melsungen), Kohrsolin (Bode Chemie), Neoquat S (Dr. Weigert), Incidin Rapid (Ecolab Healthcare), Bacillocid Spezial (Bode Chemie), Neoform K Spray (Dr. Weigert), Apesin Desinf. Spray (Tana), Nüscosept 100 (Dr. Nüsken), Antisept T (Fink Tec), Apesin AP 100 0,50% Lösung (Tana), Perform Pulver 2% Lösung (Schülke und Mayr)</p> <p>Observe the operating instructions of the respective manufacturer. If disinfectants other than those stated are used, test them on a less exposed area first.</p>	Recommendation: monthly or as required/specified at installation location
Installation location, appliance	<p>Decontamination</p> <p>The appliance is suitable for room decontamination with hydrogen peroxide H<sub>2</sub>O<sub>2</sub>.</p> <p>In this context, the values of the following application specifications must not be exceeded:            Concentration: maximum 250 ppm.            Humidity: maximum 85%.            Maximum permissible room temperature as per climate class. (see 2.4 Range of use of appliance)</p>	Recommendation: as required/specified at installation location, maximum 2x per year
Fan air slots	Cleaning	Yearly
Alarm relay	Check plug connections for tight fit.	Yearly
Sensor	Check that the plug-in connections are tight.	Yearly
Network cable	Check for damage.	Yearly or When changing the location
Tilt angle	Check that it is working properly and that it is tight.	Yearly or When changing the location
Adjustable feet/rollers	<p>Check that it is working properly, undamaged and that it is tight.</p> <p>Replace damaged parts. (see 10.4 Customer Service)</p>	Yearly

## 9.2 Defrosting appliance



### WARNING

Improper defrosting of the appliance!  
Injuries and damage.

- ▶ Do not use mechanical equipment or other methods to speed up the defrosting process other than those recommended by the manufacturer.
- ▶ Do not use electrical heating or steam-cleaning appliances, naked flames or defroster sprays to defrost.
- ▶ Do not use sharp objects to remove ice.

To maintain the functionality of the appliance, we recommend defrosting it when there is a high buildup of ice. Icing in the interior is determined by the location (e.g. high humidity), settings on the appliance and incorrect user behaviour.

If the automatic defrosting cycle is insufficient:

- ▶ Start automatic defrosting manually.  
(see 7.2.19 Defrosting )

If the problem persists, defrost the appliance manually:

- ▶ Switch off appliance. (see 7.2.2 Switching appliance on and off )
- ▶ Pull out mains plug.
- ▶ Store refrigerated items elsewhere.
- ▶ Leave appliance door open during defrosting process.
- ▶ Absorb any remaining defrost water with a cloth and clean the appliance.

## 9.3 Cleaning the appliance

### 9.3.1 Preparing



### WARNING

Short-circuit hazard due to live parts!  
Electric shock or damage to the electronics.

- ▶ **Switch off the appliance.**
- ▶ Pull out mains plug or switch off fuse.



## WARNING

Risk of fire

- ▶ Do not damage the refrigeration circuit.

- ▶ Empty the appliance.
- ▶ Pull out the mains plug.
- ▶ Observe the notes on transporting the appliance.

### 9.3.2 Cleaning housing

#### NOTICE

Improper cleaning!

Damage to the appliance.

- ▶ Only use soft cleaning cloths and ph-neutral all-purpose cleaners.
- ▶ Do not use abrasive sponges or steel wool which may cause scratches.
- ▶ Do not use any sharp or abrasive cleaning agents, nor any that contain sand, chloride or acid.



## WARNING

Risk of injury and damage as a result of hot steam!

Hot steam can lead to burns and can damage the surfaces.

- ▶ Do not use any steam cleaners!

#### NOTICE

Risk of damage due to short circuit.

- ▶ When cleaning the appliance, make sure no water gets into the electrical components.

- ▶ Wipe the housing down with soft, clean cloth. If very dirty, use lukewarm water with a neutral cleaner. Glass surfaces can also be cleaned with glass cleaner.
- ▶ Clean condenser coil each year. If the condenser coil is not cleaned, this significantly reduces the efficiency of the appliance.

### 9.3.3 Cleaning interior



## WARNING

Short-circuit hazard due to live parts!

Electric shock or damage to the electronics.

- ▶ **Switch off the appliance.**
- ▶ Pull out mains plug or switch off fuse.



## WARNING

Risk of injury and damage as a result of hot steam!

Hot steam can lead to burns and can damage the surfaces.

- ▶ Do not use any steam cleaners!

#### NOTICE

Improper cleaning!

Damage to the appliance.

- ▶ Only use soft cleaning cloths and ph-neutral all-purpose cleaners.
- ▶ Do not use abrasive sponges or steel wool which may cause scratches.
- ▶ Do not use any sharp or abrasive cleaning agents, nor any that contain sand, chloride or acid.

#### Note

Do not damage or remove the type plate on the inside of the appliance. The type plate is important for Customer Service. (see 10.4 Customer Service)

- ▶ Open the door.

- ▶ Empty the appliance.
- ▶ Clean interior and equipment parts with lukewarm water and a little detergent. Do not use any gritty or acidic cleaning agent or any chemical solvent.

### 9.3.4 After cleaning

- ▶ Wipe appliance and equipment parts dry.
- ▶ Connect and switch on appliance. Once the temperature is sufficiently cold:
  - ▶ put in items for refrigeration goods.
  - ▶ Repeat cleaning regularly.
- ▶ Clean and remove dust from the refrigeration unit with heat exchanger once a year.

## 9.4 Replacing appliance battery

In the event of a power failure, the appliance battery is used to record temperature history, alarm and service messages and to show the alarm messages on the display for approximately 12 hours. During initial commissioning, the battery may take up to 24 hours to charge and be in proper working order.

A replacement battery is available from customer service (see 10.4 Customer Service).

### 9.4.1 Replacing battery



## WARNING

Short-circuit hazard due to live parts!

Electric shock or damage to the electronics.

- ▶ **Switch off the appliance.**
- ▶ Pull out mains plug or switch off fuse.

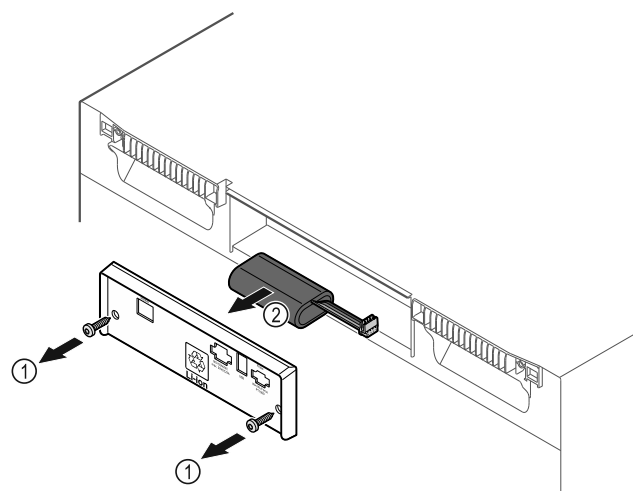

Fig. 184

- ▶ Unscrew screws and remove cover from the back of the appliance Fig. 184 (1).
- ▶ Disconnect and remove battery Fig. 184 (2).
- ▶ Install replacement battery.
- ▶ Close cover and screw in screws.
- ▶ Reconnect mains power cable.

#### Note

- ▶ The battery must be sent for separate waste treatment for batteries and must be disposed of in an expert and proper manner in accordance with the regulations and laws which apply locally. **Do not damage or short circuit the battery!**

## 10 Customer help

### 10.1 Technical specifications

Temperature range	
Freezing	-9 °C to -35 °C

Maximum load per shelf <sup>A)</sup>			
Appliance width	550 mm	600 mm	750 mm
Grid shelves	--	45 kg	60 kg
Glass shelf	40 kg	40 kg	40 kg
Drawer (freezer appliances)	15 kg	15 kg	15 kg

A) Heavier loads may result in a slight bending of the shelves.

Maximum total load and net weight		
Model (see 3.2 Appliance dimensions)	Maximum total load	Net weight
SFF.. 4001	270 kg	76 kg
SFFvh 5501	300 kg	104 kg

Net capacity
See net capacity on the type plate. (see 2.2 Overview of appliances and equipment)

Lighting	
Energy efficiency class <sup>A)</sup>	Light source
This product contains one or more energy efficiency class F light sources	LED

A) The appliance may contain light sources with different energy efficiency classes. The lowest energy efficiency class is indicated.

WLAN frequency specification	
Frequency band	2.4 GHz
Maximum radiated power	<100 mW
Purpose of the wireless equipment	Integration in the local WiFi network for data communication

Set-up conditions	
Degrees of pollution (surrounding the appliance)	PD2
Ambient temperature	+10 °C to +35 °C
Maximum relative ambient moisture	75%, not condensing
Maximum operating elevation (metres above sea level)	2000 m

Electrical values	
Nominal voltage	220-240 V ~
Frequency	60 Hz
Connected load	2,0 A
Maximum mains fluctuation	+/-10%
Overvoltage categories	II

Data as per DIN 13277 measured at -30 °C				
Model	Energy consumption (kWh/24h)	Temperature increase - power failure (min.)	Temperature homogeneity (°K)	Temperature consistency (°K)
<b>4001</b>	1,170	243	1,5	8,1
<b>5501</b>	2,282	236	4,7	4,0

Appliance battery	
Type	1S2P/NCR 18650BF
Nominal voltage	3.6 V DC
Capacity	6.7 Ah

### 10.2 Technical fault

Your appliance is designed and built to ensure it works reliably and has a long service life. In the unlikely event that a fault occurs during operation, please check whether the fault is due to an operating error. If this is the case, you will be charged for the cost incurred even if this falls within the warranty period.

You can fix the following faults yourself.

#### 10.2.1 Appliance function

Defect	Cause	Remedy
<b>The appliance is not working.</b>	→ The appliance is not switched on.	▶ Switch on the appliance.
	→ The mains plug is not properly plugged into the socket.	▶ Check the mains plug.
	→ There is something wrong with the fuse in the socket.	▶ Check fuse.
	→ Power cut	▶ Keep the appliance closed. ▶ If necessary move the refrigerated/frozen items to another fridge or freezer if the power is off for a prolonged period.
	→ The IEC socket is not plugged into the appliance correctly.	▶ Check the IEC socket.

Defect	Cause	Remedy
<b>Temperature is not cold enough.</b>	→ The appliance door is not closed properly.	▶ Close appliance door.
	→ Ventilation is not sufficient.	▶ Clear ventilation grille and clean it.
	→ The ambient temperature is too high.	▶ Ensure the correct ambient conditions: (see 2.4 Range of use of appliance)
	→ The appliance was opened too many times or for too long.	▶ Wait to see if the appliance goes back to the required temperature by itself. If not, contact Customer Service. (see 10.4 Customer Service)
	→ The temperature is set incorrectly.	▶ Set a colder temperature and check after 24 hours.
	→ The appliance is too close to a heat source (oven, radiator, etc).	▶ Change where the appliance or the heat source are located.
<b>Frost formation on the housing frame and/or on the inside of the door.</b>	→ Door seal is damaged.	▶ Replace the door seal.
	→ You have set the temperature too cold or you have not opened the door often enough.	▶ The appliance is not malfunctioning; simply remove any condensation with a cloth.

### 10.3 Data recording

If you have performed a data backup to the USB stick on the appliance (see 7.2.20 Data download (data backup) ), you can analyse the saved text files.

The following files are saved on the USB stick after the data backup:

Event_Log_*.log	Event log
Temperature_Log_*.log	Temperature curve file
Service_Info.log	This file is only intended for customer service.
Download_Info.txt	This file contains information about the appliance and the checksums of the downloaded files.

The files Event\_Log\_\*.log and Temperature\_Log\_\*.log are numbered sequentially after a defined file size has been reached (000, 001, 002, etc.).

#### Log file Event\_Log\_\*.log and Temperature\_Log\_\*.log:

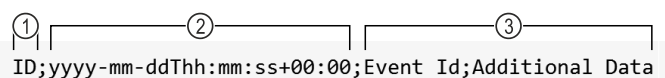

Fig. 185 Example illustration

- (1) Sequential numbering
- (2) Date and time (UTC)
- (3) Data fields

The individual values are separated by semicolons (;).

#### Data fields Event\_Log\_\*.log:

Event Id; Additional Data  
(see 10.3.1 Event log → Event\_Log\_\*.log)

#### Data fields Temperature\_Log\_\*.log:

Control Sensor Zone 0; Product Sensor Zone 0; Safety-Device Sensor Zone 0; Evaporator Zone 0; Control Sensor Zone 1; Evaporator Zone 1; Ambient  
(see 10.3.2 Temperature curve file → Temperature\_Log\_\*.log)

#### 10.3.1 Event log → Event\_Log\_\*.log

##### 10.3.1 A

Event Id	Additional Data		
<b>A = Alarm</b>	<b>0</b> = The door alarm warns the user if they open the door for too long or forget to close it.	<b>0 to 3</b> = The zone in which the event occurred.	<b>0</b> = Off <b>1</b> = On <b>2</b> = Confirmed
<b>A = Alarm</b>	<b>6</b> = The appliance checks cyclically whether all sensors are functioning properly. Otherwise, emergency mode and the alarm are triggered.	<b>0 to 3</b> = The zone in which the event occurred.	<b>0</b> = Off <b>1</b> = On <b>2</b> = Confirmed
<b>A = Alarm</b>	<b>12</b> = The power failure alarm warns the user after a power failure that the appliance became too warm during the power failure.	<b>0 to 3</b> = The zone in which the event occurred.	<b>0</b> = Off <b>1</b> = On <b>2</b> = Confirmed

# Customer help

Event Id	Additional Data		
A = Alarm	<b>13</b> = The power failure alarm warns the user after a power failure that the appliance became too cold during the power failure.	<b>0 to 3</b> = The zone in which the event occurred.	<b>0</b> = Off <b>1</b> = On <b>2</b> = Confirmed
A = Alarm	<b>45</b> = The temperature alarm is activated when the displayed temperature leaves the upper temperature range for the configured time.	<b>0 to 3</b> = The zone in which the event occurred.	<b>0</b> = Off <b>1</b> = On <b>2</b> = Confirmed
A = Alarm	<b>48</b> = The temperature alarm is activated when the displayed temperature leaves the lower temperature range for the configured time.	<b>0 to 3</b> = The zone in which the event occurred.	<b>0</b> = Off <b>1</b> = On <b>2</b> = Confirmed
A = Alarm	<b>54</b> = The appliance failure alarm is activated if an electronic component (sensor or actuator with feedback) has a fault and the appliance failure functionality is configured.	<b>0 to 3</b> = The zone in which the event occurred.	<b>0</b> = Off <b>1</b> = On <b>2</b> = Confirmed
A = Alarm	<b>127</b> = The warning is activated when the data logger detects a power failure in the local 13 V system.	<b>0 to 3</b> = The zone in which the event occurred.	<b>0</b> = Off <b>1</b> = On <b>2</b> = Confirmed

## 10.3.1 B

Event Id	Additional Data	
B = Data logger error	<b>I</b> = Info <b>W</b> = Warning <b>E</b> = Error <b>R</b> = Reset <b>A</b> = Assert	Internal event log data for customer service.

## 10.3.1 C

Event Id	Additional Data	
C = Compressor	<b>0 to 3</b> = The zone in which the event occurred.	<b>0</b> = Off <b>1</b> = On

## 10.3.1 DF

Event Id	Additional Data	
DF = Defrosting	<b>0 to 3</b> = The zone in which the event occurred.	<b>0</b> = Off <b>1</b> = On

## 10.3.1 DL

Event Id	Additional Data	
DL = Door lock	<b>0 to 3</b> = The zone in which the event occurred.	<b>0</b> = Unlocked <b>1</b> = Locked <b>2</b> = Emergency opening

## 10.3.1 DR

Event Id	Additional Data	
DR = Door	<b>0 to 3</b> = The zone in which the event occurred.	<b>0</b> = Closed <b>1</b> = Open

## 10.3.1 R

Event Id	Additional Data	
R = Relay status	<b>0</b> = Alarm relay <b>1</b> = Safety relay	<b>0</b> = Closed <b>1</b> = Open

## 10.3.1 S

Event Id	Additional Data				
S = Changes to settings	0 = Status of a zone has changed.	0 = Zone 0 is switched off. 1 = Zone 0 is switched on. 3 = Zone 0 not available.	0 = Zone 1 is switched off. 1 = Zone 1 is switched on. 3 = Zone 1 not available.	0 = Zone 2 is switched off. 1 = Zone 2 is switched on. 3 = Zone 2 not available.	
S = Changes to settings	1 = Time and date change	Set time value in ISO format, e.g. <b>2020-05-20T17:02:00</b>			
S = Changes to settings	2 = Password	1 = Smart-Lock code 2 = Display-sperre-Code	0 = Internal parameter		
S = Changes to settings	3 = Software version	1 = User Interface 127 = Power-board	0 to 255 = Major Version	0 to 255 = Minor Version	0 to 255 = Patch Version
S = Changes to settings	4 = Temperature alarm limit values	0 to 3 = The zone in which the event occurred.	<p>0 = eDataloggerSettingTemperatureAlarm-MinAbsolute: If the temperature is above this value, the display temperature is rounded to the setpoint temperature.</p> <p>1 = eDataloggerSettingTemperatureAlarm-MinRelativ: If the temperature is above the setpoint temperature minus this value, the display temperature is set to the setpoint temperature.</p> <p>2 = eDataloggerSettingTemperatureAlarm-MaxAbsolute: If the temperature is below this value, the display temperature is rounded to the setpoint temperature.</p> <p>3 = eDataloggerSettingTemperatureAlarm-MaxRelativ: If the temperature is below the setpoint temperature plus this value, the display temperature is set to the setpoint temperature.</p> <p>4 = eDataloggerSettingTemperatureAlarm-DelayUpperTemperature: After this time, the temperature alarm is activated if the display temperature is warmer than the rounding value.</p> <p>5 = eDataloggerSettingTemperatureAlarm-DelayLowerTemperature: After this time, the temperature alarm is activated if the display temperature is colder than the rounding value.</p> <p>6 = eDataloggerSettingTemperatureAlarm-Repeat: After this time, the temperature alarm becomes active again after it has been cancelled. If the value is set to 0, the function is switched off.</p>		-255 to 255 = The new temperature alarm limit values.
S = Changes to settings	5 = Calibration offset for sensors	<p>0 = Ambient temperature sensor</p> <p>1 = Safety thermostat sensor</p> <p>2 = C Sensor (control sensor) Zone 0</p> <p>3 = Evaporator temperature sensor zone 0</p> <p>4 = C Sensor (control sensor) Zone 1</p> <p>5 = Evaporator temperature sensor zone 1</p> <p>6 = P sensor (product sensor)</p>		-255 to 255 = Calibration offset in Celsius	
S = Changes to settings	6 = Target temperature	0 to 3 = The zone in which the event occurred.		Set temperature in degrees Celsius, e.g. <b>5.00</b>	

# Customer help

Event Id	Additional Data		
S = Changes to settings	7 = Defrosting parameters	0 to 3 = The zone in which the event occurred.	0 to 65535 = Interval in minutes
S = Changes to settings	8 = Alarm forwarding	00000001 = Door alarm is displayed as an external alarm. 00000010 = Temperature alarm is displayed as an external alarm. 00000011 = Door alarm and temperature alarm are displayed as external alarms. 00000111 = Each alarm is mapped as an external alarm.	

## 10.3.1 U

Event Id	Additional Data	
U = Data recording	0 = Data logger status	0 = Off 1 = On
U = Data recording	1 = USB command	-1 = Function test 0 = Formatting USB stick 3 = Temperature curve is created 5 = Event log file is created 9 = Service_Info.log is created 15 = All log files are created
U = Data recording	2 = USB status	-8 = Power supply interrupted during the write process -7 = USB stick not compatible -6 = Power supply interrupted -5 = Formatting error -4 = USB stick removed during the write process -3 = USB stick full or write-protected -2 = USB stick not FAT32 formatted -1 = No USB stick connected 0 = Deactivated 1 = Ready 2 to 100 = Percentage progress of the executed command

## 10.3.2 Temperature curve file → Temperature\_Log\_\*.log

The entire temperature curve of the various sensors is recorded. The recording **always** takes place in degrees Celsius.

Control Sensor Zone 0	Product Sensor Zone 0	Safety-Device Sensor Zone 0	Evaporator Zone 0	Control Sensor Zone 1	Evaporator Zone 1	Ambient
C-sensor (control sensor) Zone 0	P-sensor (product sensor) Zone 0	Safety thermostat sensor Zone 0	Evaporator sensor Zone 0	C-sensor (control sensor) Zone 1	Evaporator sensor Zone 1	Ambient temperature sensor
3.89	4.10	3.69	4.00			18.81

*Example of a single-zone appliance*

Control Sensor Zone 0	Product Sensor Zone 0	Safety-Device Sensor Zone 0	Evaporator Zone 0	Control Sensor Zone 1	Evaporator Zone 1	Ambient
C-sensor (control sensor) Zone 0	P-sensor (product sensor) Zone 0	Safety thermostat sensor Zone 0	Evaporator sensor Zone 0	C-sensor (control sensor) Zone 1	Evaporator sensor Zone 1	Ambient temperature sensor
3.89	4.10	3.69	4.00	-18.05	-18.21	18.81

*Example of a multi-zone appliance*

## 10.4 Customer Service

First check whether you can remedy the fault yourself. If this is not the case, please contact Customer Service.

You can find the address in the enclosed brochure "Liebherr-Service" or at [home.liebherr.com/service](http://home.liebherr.com/service).

## 10.4.1 Contacting Customer Service

Make sure you have the following appliance data at the ready:

- Appliance name (model and index)
- Service no. (Service)
- Serial no. (S no.)
- ▶ Access the appliance information via the display (see 7.2.16 Device information ).
- or-
- ▶ Refer to the type plate for appliance information. (see 10.5 Type plate)
- ▶ Note down appliance information.
- ▶ Inform Customer Service: Report faults and the appliance information.
- ▶ This will help us to provide a fast and focussed service.
- ▶ Follow any further instructions provided by Customer Service.

## 10.5 Type plate

The type plate is inside the appliance. See appliance overview.

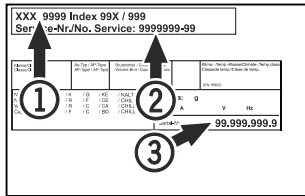

Fig. 186

- (1) Appliance designation      (3) Serial No.  
(2) Service No.

## 11 Shutting down

- ▶ Empty the appliance.
- ▶ Switch off the appliance.
- ▶ Pull the mains plug out of the socket.
- ▶ Remove the IEC socket if required: Pull the IEC socket out of the appliance plug and move it to the left and right at the same time.
- ▶ Clean appliance (see 9.3 Cleaning the appliance) .
- ▶ If present: Remove the covers and insulation from the sensor feed-through to prevent mould forming.
- ▶ Leave the door open so that no bad odours form.

### Note

Damage to the appliance and malfunctions!

- ▶ After shutting down, only store the appliance at the permitted room temperature of between -10 °C and +50 °C.

## 12 Disposal

### 12.1 Preparing appliance for disposal



Liebherr uses batteries in some of its appliances. In the EU, for environmental reasons, legislation obliges the end user to remove these batteries before disposing of old appliances. If your appliance contains batteries, a corresponding notice is attached.

Lamps If you can remove the lamps yourself without destroying them, also remove these before disposal.

- ▶ Take the appliance out of operation.
- ▶ Appliances with batteries: remove the batteries. For description, see **Maintenance** chapter.
- ▶ If possible: remove lamps without destroying them.

### 12.2 Disposing of the appliance in an environmentally friendly manner



The appliance still contains valuable materials and must be disposed of separately from unsorted municipal waste.



Dispose of batteries separately from the old appliance. To do this, you can return the batteries free of charge to retailers as well as recycling centres and collection centres for recyclable materials.

Lamps

Dispose of removed lamps via the respective collection systems.



### WARNING

Leaking coolant and oil!

Fire. The coolant contained in the appliance is eco-friendly, but also flammable. The oil contained in the appliance is flammable. Escaping coolant and oil can ignite if the concentration is high enough and in contact with an external heat source.

- ▶ Do not damage the pipelines of the coolant circuit and the compressor.

- ▶ Observe the notes on transporting the appliance.
- ▶ Transport the appliance without damaging it.
- ▶ Dispose of batteries, lamps and the appliance according to the above specifications.

## 13 Additional information

Further information on warranty conditions can be found in the enclosed service brochure or on the Internet at <https://home.liebherr.com>.





Pass on this info in the event of a device fault:

Model identifier /  
Inventory number:

## Quick Start Guide for everyday use

### Information about using this Quick Start Guide:

- This Quick Start Guide is not a substitute for the full operating instructions nor is it a substitute for appliance training.
- This Quick Start Guide provides support for everyday use and handling the appliance.
- Read the full operating instructions and the safety notes contained therein.

This quick start guide is for: SFFvh 55..



Scanning the QR code will open the full operating instructions:



### Intended use

This laboratory freezer is suitable for professional storage of products at temperatures between -9 °C and -35 °C.

### Foreseeable incorrect use

Do not use the appliance for the following applications:

- Storage and refrigeration of:
  - Chemically unstable, flammable or corrosive substances
  - Blood, plasma or other body fluids for the purpose of infusion, application or introduction in the human body
- Use in potentially explosive atmospheres
- Use outdoors or in areas exposed to dampness and splashing water

### When stocking, observe the following points:

- Position grid shelves according to the height required.
- Observe maximum load.
- When the storage temperature has been reached, load the appliance (compliance with cold chain).
- Produce for cooling must not come into contact with the evaporator on the rear wall.
- Keep liquids in closed containers.
- Leave space when storing refrigerated goods to ensure good air circulation.

## Status display



Fig. 187

- (1) Actual temperature
- (2) Alarm status
- (3) Defrosting status
- (4) Door opening status

## Displaying temperature recording

The temperature recording displays the length of the recording and the minimum and maximum temperatures measured during this period of time.



Fig. 188

## Resetting temperature recording

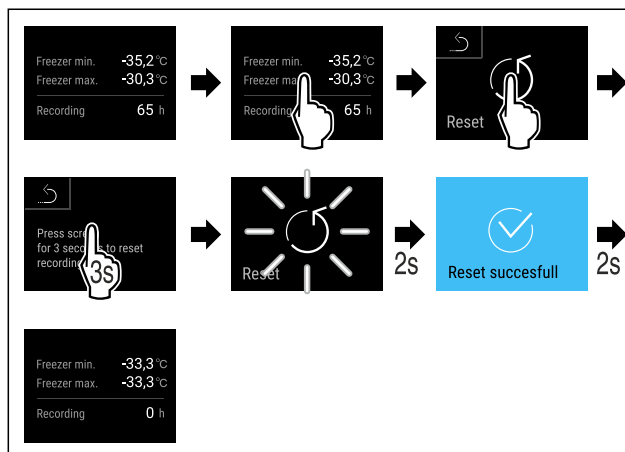

Fig. 189

## Unlocking appliance

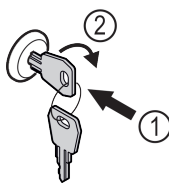

Fig. 190

- ▶ Insert the key. Fig. 190 (1)
- ▶ Turn the key clockwise by 90°. Fig. 190 (2)
- ▶ The appliance is unlocked.

## Displaying alarm log

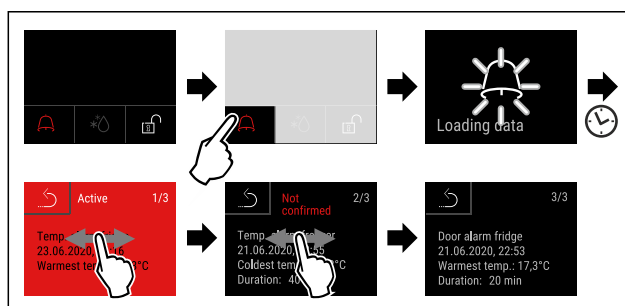

Fig. 191 Example shows an active alarm, an unconfirmed alarm, and a confirmed alarm.

- ▶ Alarm log shows active, confirmed or unconfirmed alarms (maximum 10 alarms).
- ▶ To delete the alarm log: See operating instructions.

## Cleaning appliance

- ▶ Empty the appliance.
- ▶ Pull out the mains plug.
- ▶ Observe the information in the operating instructions.

## Quick Start Guide for everyday use

---

- ▶ Dry the appliance and equipment thoroughly after cleaning.
- ▶ Connect the appliance.
- ▶ Switch on the appliance.
- ▶ Load the appliance once the storage temperature is reached.



### What should I do if there is a fault?

A message appears in the display if there is a fault.  
Messages have different meanings:

Symbol colour in the display	Meaning	Remedy
<b>YELLOW</b>	<b>Reminder</b> Reminder of general procedures. You can carry out these procedures to eliminate the message.	Consult the operating instructions and perform the troubleshooting steps.
<b>RED</b>	<b>Warning</b> Appears when there are malfunctions. You can eliminate simple malfunctions yourself.	Consult the operating instructions and perform the troubleshooting steps.
If you cannot remedy the fault yourself, contact a competent member of staff or your nearest customer service outlet.		



[home.liebherr.com/fridge-manuals](https://home.liebherr.com/fridge-manuals)

**EN** ORIGINAL OPERATOR'S MANUAL

Issue date: 20260226

**Part number index: 7083342-00**

Liebherr Hausgeräte Lienz GmbH  
Dr.-Hans-Liebherr-Strasse 1  
A-9900 Lienz  
Österreich

