R 9350

Generation 6

LIEBHERR

Mining excavator



Powertrain options

Cummins: 1,120 kW (FCO)
1,500 HP
Electric: 1,200 kW (50 Hz, 60 Hz)
1,610 HP

Backhoe configuration

Overall weight: 302 tonnes
333 tons
Bucket payload: 34 tonnes
37.5 tons

Face shovel configuration

Overall weight: 310 tonnes
342 tons
Bucket payload: 32.5 tonnes
36 tons

Overview
R 9350





Diesel drive 1,120 kW / 1,500 HP
Electric drive 1,200 kW / 1,610 HP



BH 18.7 m³ / 24.5 yd³
FS 18 m³ / 23.5 yd³



BH 302 tonnes / 333 tons
FS 310 tonnes / 342 tons



Performance
Productive, efficient and reliable





The R 9350 is built to outperform all competitors in the medium class mining market. Boasting a 18.7 m³ / 24.5 yd³ bucket capacity in standard configuration, the R 9350 is the ideal machine to load a fleet of 100 t mining trucks. Available in diesel or electric versions, the R 9350 offers the flexibility to perform many specific applications.

Fast and precise movement

Powerful drive system

The R 9350 is equipped with a Cummins diesel engine which has been specifically adapted to withstand the most extreme environments and to reach the highest uptime performance for maximum productivity. The electric drive system is a perfect alternative for specific mine layouts.

Fast cycle time

Rather than using open hydraulic circuit, the R 9350 employs a closed-loop swing circuit to enable maximum swing torque while retaining the full oil flow for the working circuit. The independent swing circuit in combination with the powerful drive system leads to fast arm motion, which contributes to faster cycle times.

Precise machine motions

The R 9350 design integrates electronic control system allowing easy control even when simultaneous movements are required. Smooth attachment motions are achieved through cylinder damping system.

High digging and lifting capabilities

High digging forces & power-oriented energy management

Designed for the best mechanical force distribution, the production-tailored attachment delivers high digging and lifting forces. Integrating Liebherr-made cylinders and a wide range of buckets with mining-optimized GET, the R 9350's attachment ensures the highest forces, easy bucket penetration and high fill factor to perform even in the most demanding conditions.

High altitude package (optional)

Designed to offer maximum efficiency and productivity for operation in high altitude:

- Solution integrated in machine structure
- Adapted engine
- Pressurized hydraulic tank
- Available with the arctic package

Engine / motor options

Diesel engine available versions:

- Cummins QSK 45
- Fuel consumption optimized version
- Electrical motor (optional)
- 3 phase AC squirrel cage motor
- Voltage on request
- 50 or 60 Hz frequency

Exclusive EVO bucket solution

- Liebherr patented EVO design to maximize the loading capacity
- Optimized Liebherr GET and wear package according to customer application (GP, HD, XHD)
- Ensures optimal penetration efficiency
- Single GET hammerless locking system for safe and easy maintenance
- Fully patented GET system design for optimal penetration / lifetime
- 4 tooth profiles available for various range of applications

The R 9350 follows the Liebherr design philosophy of maximizing the machine's performance by improving the efficiency of all individual subsystems. Engineered for excellent serviceability, the machine is designed to ensure maximum uptime. The R 9350's spacious cab creates a comfortable working environment ensuring peak operator performance, every shift.



Built for maximum profitability

Electro-hydraulic system efficiency

Liebherr hydraulic technology in combination with the precision of electronic control contributes to the R 9350's energy optimization. The high-pressure hydraulic system and the optimized pipe and hose layout maximize usable power transmission. The hydraulic pumps are electronically managed to provide optimal pressure compensation and oil flow management. The hydraulic system is independently regulated over the engine circuit for the best operational efficiency.

Cooling system efficiency

Liebherr's large dimensioned cooling system reduces fan power consumption and ensures an ideal machine temperature. The hydrostatic fans operate always on the required level.

Closed Loop Swing Circuit

The Liebherr mining excavators are all equipped with a closed loop swing circuit. Kinetic energy is recovered when the swing motion is used during deceleration, to drive the main and auxiliary pumps, reducing fuel consumption.

Comfortable cab for efficient work

The large and spacious cab which equips the R 9350 offers ideal working conditions and optimal operator's comfort. Mounted on silent blocks, the cab design reduces vibrations and limit noise pollution to provide a quiet environment.

Extended components lifetime

The R 9350's hydraulic oil filtration systems remove fluid contaminants to offer the highest rate of hydraulic components durability. To maintain oil quality, all return hydraulic oil flow goes through a fine filtration system (15/5 µm) and oil tank is sized to considerably extend the time between service intervals.



Hydraulic system efficiency

The R 9350's hydraulic system is designed for an optimized hydraulic power management via the:

- Closed-loop swing circuit
- Pressureless boom down function
- Electronic hydraulic pumps management
- Electro-hydraulic control system
- Optimized pipe and hose layout

Central service station

The service flap is hydraulically actuated and accessible from the ground level allowing for fast maintenance:

- Hydraulic oil
- Engine oil
- Splitter box oil
- Swing gearbox oil
- Attachment / swing ring bearing grease with filters
- Swing ring teeth grease with filter
- Windshield water
- Fuel (non-pressurised refueling system in option)

Comfort-oriented cab design

An array of features:

- Tinted laminated safety glass
- Armored front and attachment side windows
- Heavy duty sun louvers
- Adjustable air suspended seat
- Pressurised A/C system
- Pressurization to prevent dust penetration
- Trainer seat

Quality

The Liebherr

trademark



With over 50 years of innovative thinking, engineering and manufacturing excellence, Liebherr sets the industry standard for advanced equipment design and technology tools to provide the most up-to-date product responding to the requirements of the mining customers.

Long-lasting job performances

Maximized components lifetime

The R 9350 is equipped with an automatic single line lubrication system for the entire attachment and swing ring. All greasing points are suitably protected against external damages. This extends component life and ensures constant performance over the excavator's operational life.

Rugged undercarriage structure

The R 9350 is mounted on a heavy duty fatigue resistant undercarriage. The swing ring is reinforced to provide an improved superstructure weight distribution. Designed and built for both shovel and backhoe configurations, the enlarged undercarriage offers an efficient ground bearing pressure repartition providing the necessary stability and reliability.

Liebherr components integration

As an OEM, Liebherr has built a solid reputation for its development and production of high quality strategic mining components. The R 9350 integrates robust and reliable

mining optimized components that are developed, manufactured and controlled by Liebherr ensuring reliability and high performance for the entire machine.

Machine reliability survey

Based on years of experience and the systematic measurement of key performance indicators of the machine behavior in the field, the Liebherr Mining Reliability Engineering Group is constantly seeking new ways to enhance reliability.

Quality management continuous improvement

Liebherr quality begins during machine design and simulations. Liebherr meets the highest standards for special selections of steels and casting materials. Based on the expertise of certified internal auditors and a highly qualified workforce, all manufacturing process steps are devised to provide the most comprehensive control, monitoring and traceability. Liebherr-Mining Equipment Colmar SAS is ISO 9001 certified.



Reliable attachment design

Backhoe or face shovel attachments are built to face all standard and specific applications:

- Use of advanced welding techniques
- Reinforced with strategically located castings in high stress areas
- Heat treatment to reduce residual stresses and increase fatigue life
- Designed for maximum structure life
- Use of cutting-edge engineering tools such as Finite Element Analysis and Fatigue Life Analysis



Quality commitment

- Liebherr-Mining Equipment Colmar, France, ISO 9001 certified
- Compliance of materials tested in laboratory
- Quality control during the stages of production
- Vertical integration practice
- CE certified (2006/42/EC), MDG 15 and MDG 41 compliant



Arctic package (optional)

Designed for reliability in regions with temperatures of down to $-50\text{ }^{\circ}\text{C}$ / $-58\text{ }^{\circ}\text{F}$:

- Integrated into machine structure
- Start up easily even at very low temperatures
- Increases machine availability and components lifetime
- Optimum operator comfort even in harsh temperature conditions
- Facilitate machine servicing

Service

Where you need it, when you need it

A daily partner to the customer, for global long term sustainable performances, Liebherr implements tailored solutions from technical support, spare parts and logistics solutions to global maintenance for all types of equipment, all over the world.



Troubleshoot advisor platform

- Unique maintenance system to help you identify problems
- Easy and friendly-user interface
- Compatible with mobile, tablet or laptop
- Regular updating of the database
- Procedures described by specialist with images and videos

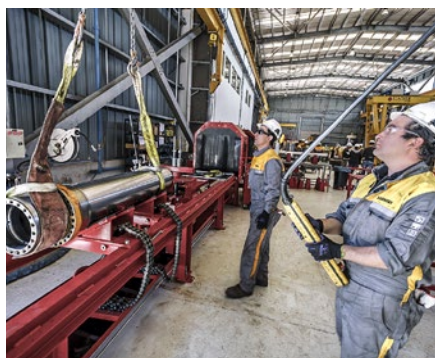

The Liebherr-Mining remanufacturing program

- Liebherr certified quality
- As-new warranty
- OEM expertise
- Reduced costs and investment
- Fast availability



MyLiebherr customer portal

- Easy access parts online
- Available any time anywhere
- User friendly interface
- Online ordering
- Save time and money



Customer support

International service organization

The Liebherr service support has always been an important focus for the company. Complete service during all operating phases from machinery installation to problem solving, spare parts inventory and technical service. Our service team is close to our customers, delivering the best specific maintenance solution to reduce both equipment downtime and repair costs.

Complete training programs

The Liebherr mining training system provides blended training sessions for operator and maintenance staff to encourage productive, cost-effective and safe mining operation. The Liebherr mining training system employs online learning programs, factory and on-site sessions and simulator training.

Remanufacturing

Reduced costs and investment

Over the course of a mining machine's lifetime, major components must be replaced to ensure continued safety, productivity and reliability. The Liebherr mining remanufacturing program offers customers an OEM alternative to purchasing brand new replacement components. Enabling customers to achieve lowest possible equipment lifecycle costs without compromising quality, performance or reliability.

Fast availability

A international service network and component facilities worldwide means that component repair services and exchange components are available to customers regardless of their location.

Genuine parts

Performance

Using genuine Liebherr components ensures the best interaction within your machine, encouraging optimal performance and most effective machine operation. For all major components, Liebherr relies on its Liebherr maintenance management system to follow and monitor service life while predicting maintenance activities.

Partnership

Liebherr regularly reviews requirements for parts and components for individual machines, based on operating hours, consumption and planned maintenance, resulting in minimized down time for customers. With access to the global stock via all Liebherr mining warehouses, you will improve productivity by having the part you need, when you need it.

Safety

Protecting your most important assets

The Liebherr R 9350 provides uncompromising safety for operators and maintenance crews. Equipped with the service flap accessible from the ground level and integrating wide open accesses, the R 9350 allows quick and safe maintenance. The R 9350's cab provides numerous features for operator safety.



Safety-first working conditions

Safe service access

The R 9350's top structure is accessible via a powered 45° stairway as standard. The robust service flap provides easy ground level access to the main service points.

Secure maintenance

All components have been located allowing effortless inspection and replacement. Numerous service lights are strategically located in the service areas to sustain suitable maintenance conditions, day or night. Emergency stops have been strategically placed in the cab, engine compartment and at ground level. The R 9350 eliminates hazards to ensure a safe environment for the service staff during maintenance.

Efficient machine protection

Protection against fire ignition

The engine compartment integrates a bulkhead wall that separates the engine from the hydraulic pumps. This reduces the risk of hydraulic oil entering the engine compartment. The turbochargers and exhaust systems are heat shielded, and all the hydraulic hoses are made from a fire resistant material to prevent the risk of fires.

Automatic fire suppression system

The R 9350 can be equipped with a fully integrated fire suppression, employing a dual agent solution to prevent and protect the machine. The fire suppression system has both automatic and manual release capabilities. E-stops, interconnected with the fire suppression system, are strategically located in the cab, over the machine, on the ground level to be easily accessible in any case by the operator or maintenance. The automatic fire suppression system is connected to the machine electronic, in case of release, the 45° access stairway is automatically activated.



Improved accessibility ease of maintenance

The machine is easily visible even by night or in extremely dusty working environments thanks to:

- 12 long-range working lights located on attachment, uppercarriage and counterweight
- Travel alarm system with light and buzzer

Machine access

Designed for safe access on the machine upperstructure via:

- Stairway and catwalks with handrails and perforated steps
- Walkways with slip-resistant surfaces
- Emergency egress with handrails in front of the excavator
- 45° access system

Commitment to employees safety

- Safe and protected access to the components
- Major components centralized to be easily accessible
- E-stops located for the operator and maintenance staff
- Maintenance fluids reach at ground level in option
- Rear and side vision system

Sustainability

Committed to our future



The Liebherr-Mining remanufacturing program

- Second life for your components
- Liebherr certified workshops
- Reduced environmental impact
- Reduced costs and investment
- Alternative to purchase brand-new replacement components

Sound attenuation package (optional)

- Machine noise attenuation without power loss
- Ideal for operation close to residential area
- Full integration into machine structure
 - Noise-optimised fan regulation
 - Larger and additional mufflers with tail pipe absorbers
 - Sound attenuation on louvers, doors and walls
- Developed with the latest noise measurement technologies

Electric drive version

- The electric drive system is an efficient alternative to diesel engine allowing:
- Less vibration resulting in higher component lifetime
 - Lower maintenance costs
 - Less noise pollution
 - No exhaust gas emissions
 - High motor efficiency
 - Maximum efficiency in cold climate conditions when combined with the arctic package



Liebherr considers the preservation of the environment as a major challenge for the present and future. Liebherr takes greater account of environmental issues in designing, manufacturing and managing machine's structures. This commitment provides solutions that allow customers to balance high performance with environmental consciousness.

Minimized impact on life

Optimized energy consumption, fewer emissions

The intelligent energy management system coordinates optimal interaction between the hydraulic system and engine output with the goal of a maximum performance with a minimum consumption. With the "Eco-Mode", the machine is set up to reduce engine load, improve significantly fuel consumption and optimize emissions.

Sustainable design and manufacturing process

Certified environment management systems

Subject to the stringent European program for the regulation of the use of chemical substances in the manufacturing process REACH*, Liebherr undertakes a global evaluation to minimize the impacts of hazardous material, pollution control, water conservation, energy and environmental campaigns.

Extended components and fluids lifetime

Liebherr is constantly working on ways to extend component life. Through the remanufacturing program, superior lubrication systems and the reinforcement of parts under stress, Liebherr can reduce frequency of part replacement. The result minimizes environmental impact and lowers the overall cost of ownership.



*REACH is the European Community Regulation on chemicals and their safe use (EC 1907 / 2006) It deals with the registration, evaluation, authorization and restriction of chemical substances.



The four pillars of the Liebherr mining division

With more than 50 years of experience in the mining industry, Liebherr has identified four key factors of customer satisfaction: Performance, Safety, Service, and Sustainability. These pillars provide structure and focus for all our activities, and embody Liebherr's customer commitments.





Performance
Productive, efficient and reliable



Safety
Protecting your most important assets



Service
Where you need it, when you need it



Sustainability
Committed to our future



Technical data

Powertrain

1 Cummins diesel engine	
Rating per SAE J1995	1,120 kW (1,500 HP) at 1,800 rpm
Model	Cummins QSK45 (FCO)
Type	12 cylinder turbocharged V-engine after-cooler two separate water cooling circuits direct injection system
Bore/Stroke	159/190 mm / 6.26/7.48 in
Displacement	45 l / 2,745 in ³
Engine cooling system	fans driven via hydraulic piston motor
Air cleaner	dry-type air cleaner with pre-cleaner, with automatic dust ejector, primary and safety elements
Fuel tank (Tier 1)	5,815 l / 1,536 gal
Fuel tank (Tier 2)	6,908 l / 1,825 gal
Electrical system	
Voltage	24 V
Batteries	4 x 180 Ah / 12 V service systems
Alternator	24 V / 260 Amp
Engine idling	automatic engine idling
Electronic engine control system	engine speed sensing over the entire engine RPM range. Provides integration of engine with other machine systems
or	

1 electric motor

Power output	1,200 kW (1,610 HP)
Type	3-phase AC squirrel cage motor
Voltage	6,000 V or 6,600 V, other voltage on request
Frequency	50 Hz (or 60 Hz)
Revolutions	1,500 rpm or 1,800 rpm
Motor cooling	integrated air-to-air heat exchanger
Starting method	inrush current limited to 2.2 full load current

Electro-hydraulic controls

Servo circuit	independent, electric over hydraulic proportional controls of each function
Emergency control	via accumulator for all attachment functions with stopped engine
Power distribution	via monoblock control valves with integrated primary relief valves and flanged on secondary valves
Flow summation	to attachment and travel drive
Control functions	
Attachment and swing	proportional via joystick levers
Travel	proportional via foot pedals or hand levers
Bottom dump bucket	proportional via foot pedals

Swing drive

Hydraulic motor	2 Liebherr axial piston motors
Swing gear	2 Liebherr planetary reduction gears
Swing ring	Liebherr, sealed triple roller swing ring, internal teeth
Swing speed	0 - 3.9 rpm
Swing-holding brake	hydraulically released, maintenance-free, multi-disc brakes integrated in each swing gear

Hydraulic system

Hydraulic pump for attachment and travel drive	4 variable flow axial piston pumps
Max. flow	4 x 754 l/min. / 4 x 199 gpm
Max. pressure	320 bar / 4,640 psi
for swing drive	2 reversible swashplate pumps, closed-loop circuit
Max. flow	2 x 390 l/min. / 2 x 103 gpm
Max. pressure	350 bar / 5,076 psi
Pump management	electronically controlled pressure and flow management with oil flow optimisation
Hydraulic tank capacity	2,200 l / 581 gal
Hydraulic system capacity	4,200 l / 1,110 gal
Hydraulic oil filter	1 high pressure safety filter after each high pressure pump + fine filtration of entire return flow (15/5 µm)
Hydraulic oil cooler	2 separate coolers, 2 temperature controlled fans driven via hydraulic piston motor

Electric system

Electric isolation	easy accessible battery isolators
Working lights	high brightness LED lights: - 4 on working attachment - 2 on cabin - 3 on RHS of uppercarriage - 3 on LHS of uppercarriage
Emergency stop switches	at ground level, in hydraulic compartment, in engine compartment, at valve bank and in operator cab
Electrical wiring	heavy duty execution in IP 65 standard for operating conditions of -50 °C to 100 °C / -58 °F to 212 °F

Uppercarriage

Design	torque resistant designed upper frame in box-type construction for superior strength and durability
Attachment mounting	parallel longitudinal main girders in box section construction
Machine access	45° access system with handrails on the cab side of the upper-carriage, full controlled descent in case of emergency stop additional emergency ladder fitted near the cab

Cab

Design	resiliently mounted, sound insulated, large windows for all around visibility, integrated falling object protection FOPS (ISO 10262)
Operator's seat	suspended, body-contoured with shock absorber, adjustable to operator's weight
Cabin windows	20.5 mm / 0.8 in tinted armored glass for front window and 18 mm / 0.7 in for right-hand side windows, all other windows in tinted safety glass, high pressure windshield-washer system 75 l / 20 gal watertank, steel sun louvers on all windows in heavy duty design
Heating system / Air conditioning	heavy duty, fully automatic, high output air conditioner and heater unit, contains fluorinated greenhouse gases HFC 134a with a Global Warming Potential (GWP) of 1430, the AC circuit contains 7.5 kg / 16.5 lb of HFC-134 representing an equivalent of 10.7 tonnes / 11.6 tons of CO ₂ , the 2 nd AC circuit (optional) contains 4.8 kg / 10.6 lb of HFC-134 representing an equivalent of 6.9 tonnes / 7.6 tons of CO ₂
Cabin pressurization	ventilation with filter, minimum pressurization of 50 Pa (ISO 10263-3)
Controls	joystick levers integrated into armrest of seat
Monitoring	via LCD-display, data memory
Rear vision system	camera installation on counterweight and right-hand side of the uppercarriage displayed over an additional LCD-display
Automatic engine shut off	engine self-controlled shut off
Destroking of main pumps	in case of low hydraulic oil level
Safety functions	additional gauges with constant display for: engine speed, hourmeter, voltmeter, safety mode for engine speed control and pump regulation
Noise level (ISO 6396)	Diesel: L _{pA} (inside cab) = Tier 1: 76 dB(A) Tier 2: 78 dB(A) Electric: L _{pA} (inside cab) = 75 dB(A)
Hand-arm vibrations	≤ 2.5 m/s ²
Whole-body vibrations	≤ 0.5 m/s ²

Undercarriage

Design	3-piece undercarriage, box-type structures for center piece and side frames (stress relieved as a standard)
Hydraulic motor	2 axial piston motors per side frame
Travel gear	Liebherr planetary reduction gear
Travel speed	0 - 2.5 - 3.3 km/h / 0 - 1.60 - 2.00 mph
Parking brake	spring engaged, hydraulically pressure released wet multi-disc brakes for each travel motor, maintenance-free
Track components	BMP 350, maintenance-free, forged double grouser pad
Track rollers / Carrier rollers	9 / 2 per side frame
Automatic track tensioner	pressurized hydraulic cylinder with accumulator and grease tensioner
Transport	undercarriage side frames are removable

Service flap

Design	hydraulically actuated service flap, with lighting easily accessible from ground level to allow: <ul style="list-style-type: none"> - fuel fast refill - hydraulic oil refill - engine oil quick change - splitterbox oil quick change - swing gearbox oil quick change - swing ring teeth grease barrel refilling via grease filter - attachment / swing ring bearing grease barrel refilling via grease filter - windshield wash water refilling other coupler type on request
--------	---

Central lubrication system

Type	single line lubrication system, for the entire attachment / swing ring bearing and teeth
Grease pumps	hydraulic pumps for both circuits
Capacity	200 l / 53 gal bulk container for attachment / swing ring bearing, separated 80 l / 21 gal container for swing ring teeth
Refill	via the service flap for both containers, fill line with grease filters
Monitoring	via a specific Liebherr control module with data memory

Attachment

Design	box-type structure with large steel castings in all high-stress areas
Pivots	sealed with double side centering with 1 single floating pin per side, all bearings with wear resistant steel bushings, bolts hardened and chromium-plated
Hydraulic cylinder	Liebherr design, all cylinders located in well protected areas
Hydraulic connections	pipes and hoses equipped with SAE split-flange connections
Kinematics	Liebherr parallel face shovel attachment geometry, electronic controlled end-cushioning

Dimensions

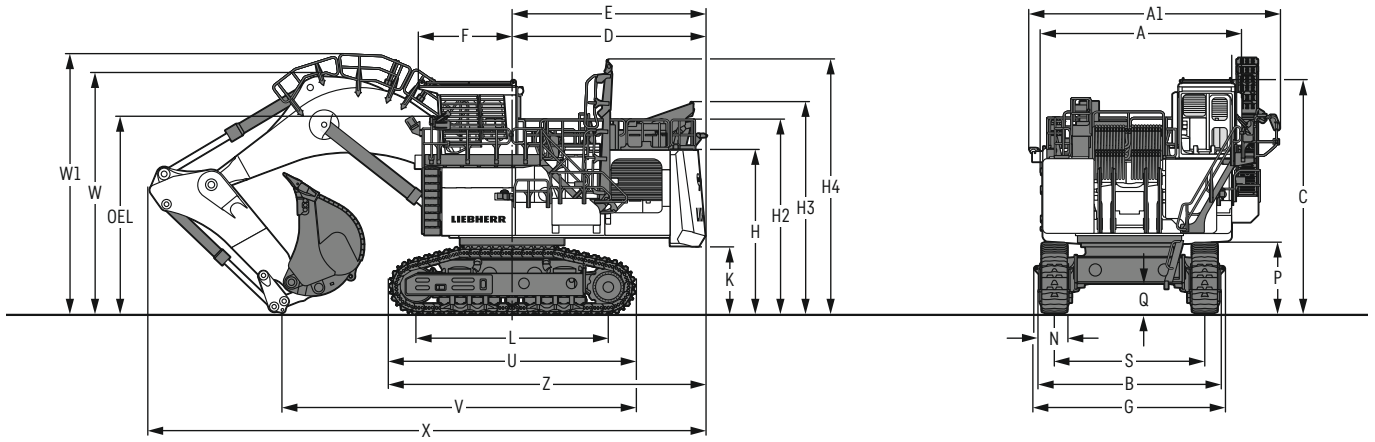

	mm / ft in
A	8,346 / 27' 5"
A1	6,300 / 20' 8"
B	6,080 / 19' 11"
C	7,950 / 26' 1"
D	6,400 / 20' 11"
E	6,700 / 22'

	mm / ft in
F	3,090 / 10' 1"
G	6,340 / 20' 10"
H	5,530 / 18' 2"
H2	6,500 / 21' 4"
H3	7,090 / 23' 3"
H4	8,500 / 27' 11"

	mm / ft in
K	2,300 / 7' 6"
L	6,385 / 20' 11"
N	850 / 2' 9"
P	2,360 / 7' 9"
Q	1,020 / 3' 4"
S	5,000 / 16' 4"

	mm / ft in
U	8,220 / 27'
V	11,800 / 38' 8"
W	8,000 / 26' 3"
W1	8,720 / 28' 7"
X	18,500 / 60' 8"
Z	10,500 / 34' 5"
OEL (Operator's eye level)	6,580 / 21' 7"

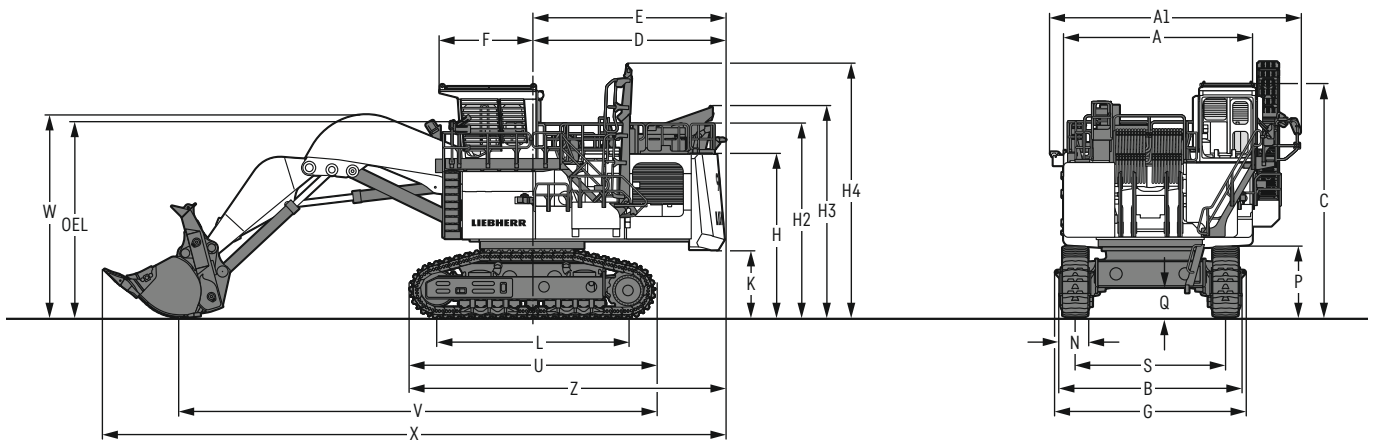

	mm / ft in
A	8,346 / 27' 5"
A1	6,300 / 20' 8"
B	6,080 / 19' 11"
C	7,950 / 26' 1"
D	6,400 / 20' 11"
E	6,700 / 22'

	mm / ft in
F	3,090 / 10' 1"
G	6,340 / 20' 10"
H	5,530 / 18' 2"
H2	6,500 / 21' 4"
H3	7,090 / 23' 3"
H4	8,500 / 27' 11"

	mm / ft in
K	2,300 / 7' 6"
L	6,385 / 20' 11"
N	850 / 2' 9"
P	2,360 / 7' 9"
Q	1,020 / 3' 4"
S	5,000 / 16' 4"

	mm / ft in
U	8,220 / 27'
V	15,900 / 52' 1"
W	7,100 / 23' 3"
X	20,700 / 67' 10"
Z	10,500 / 34' 5"
OEL (Operator's eye level)	6,580 / 21' 7"

Backhoe attachment

with mono boom 9.30 m / 30'6"

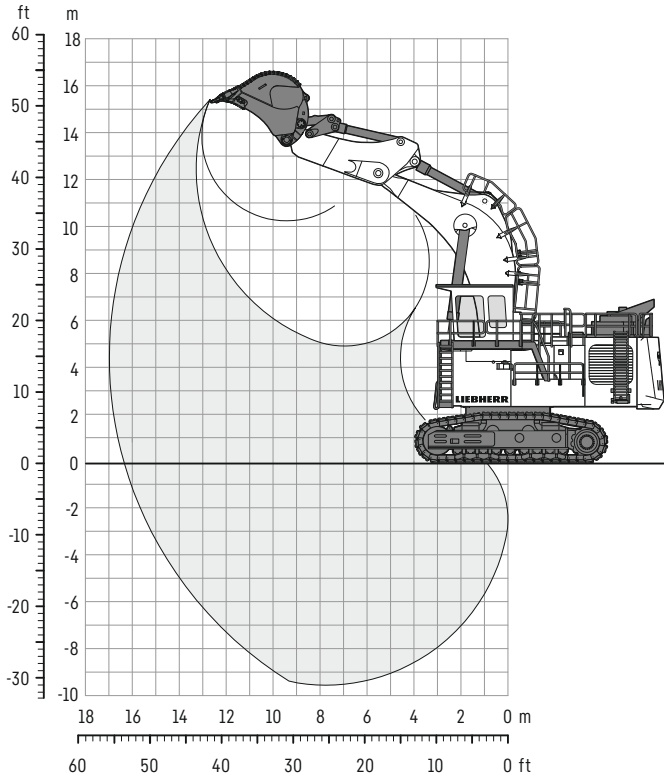

Digging envelope

Stick length	m	4.20
	ft in	13'9"
Max. digging depth	m	9.50
	ft in	31'1"
Max. reach at ground level	m	16.30
	ft in	53'5"
Max. dumping height	m	10.20
	ft in	33'5"
Max. teeth height	m	15.40
	ft in	50'6"

Forces

Max. digging force (ISO 6015)	kN	870
	lbf	195,584
Max. breakout force (ISO 6015)	kN	1,020
	lbf	229,305

Operating weight and ground pressure

The operating weight includes the basic machine with backhoe attachment and backhoe bucket 18.70 m³ / 24.46 yd³.

Pad width	mm	850
	ft in	2'9"
Weight	kg	302,000
	lb	665,800
Ground pressure*	kg/cm ²	2.51
	psi	35.63

* according to ISO 16754

Backhoe buckets

For materials class according to VOB, Section C, DIN 18300	< 5	< 5	5 - 6	5 - 6	7 - 8	7 - 8	
Typical operation according to VOB, Section C, DIN 18300	GP	GP	HD	HD	XHD	XHD	
Capacity ISO 7451	m ³ yd ³	20.00 26.2	19.30 25.2	18.70 24.5	17.80 23.3	17.00 22.2	16.00 20.9
Suitable for material up to a specific weight of	t/m ³ lb/yd ³	1.65 2,782	1.75 2,951	1.8 3,035	1.9 3,204	1.9 3,204	2.05 3,457
Cutting width	mm ft in	3,700 12'1"	3,700 12'1"	3,400 11'1"	3,300 10'9"	3,250 10'7"	3,200 10'5"
Weight	kg lb	16,950 37,368	16,200 37,715	16,400 36,156	16,200 35,715	17,650 38,912	17,410 38,382

GP: General purpose bucket with Liebherr Z140 teeth

HD: Heavy-duty bucket with Liebherr Z140 teeth

XHD: Heavy-duty rock bucket with Liebherr Z140 teeth

Face shovel attachment

with shovel boom 6.75 m / 22'1"

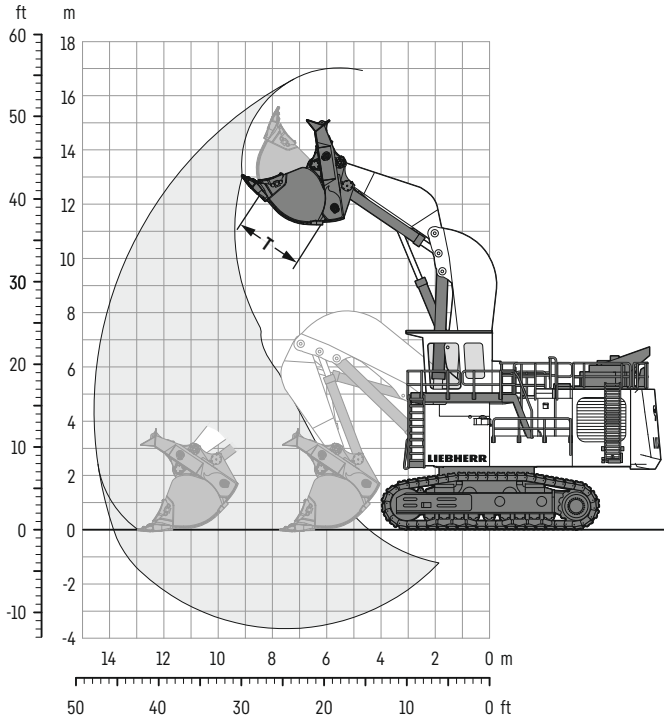

Digging envelope

Stick length	m	4.20
	ft in	13'9"
Max. reach at ground level	m	13.75
	ft in	45'1"
Max. dumping height	m	11.20
	ft in	36'8"
Max. crowd length	m	5.20
	ft in	17'
Bucket opening width T	m	2.35
	ft in	7'8"

Forces

Max. crowd force at ground level (ISO 6015)	kN	995
	lbf	223,460
Max. crowd force (ISO 6015)	kN	1,280
	lbf	287,755
Max. breakout force (ISO 6015)	kN	1,000
	lbf	224,809

Operating weight and ground pressure

The operating weight includes the basic machine with shovel attachment and bucket 18.00 m³ / 23.5 yd³.

Pad width	mm	850
	ft in	2'9"
Weight	kg	310,000
	lb	683,400
Ground pressure*	kg/cm ²	2.58
	psi	36.57

* according to ISO 16754

Face shovel buckets

For materials class according to VOB, Section C, DIN 18300	< 5	< 5	< 5	5 - 6	5 - 6	7 - 8	7 - 8
Typical operation according to VOB, Section C, DIN 18300	GP	GP	GP	HD	HD	XHD	XHD
Capacity ISO 7451	m ³	15.30	17.00	20.50	17.00	18.00	15.30
	yd ³	20.0	22.2	26.8	22.2	23.5	20.0
Suitable for material up to a specific weight of	t/m ³	2.2	2.0	1.6	1.9	1.8	1.9
	lb/yd ³	3,710	3,373	2,698	3,204	3,035	3,204
Cutting width	mm	4,100	4,100	4,100	4,100	4,100	4,100
	ft in	13'5"	13'5"	13'5"	13'5"	13'5"	13'5"
Weight	kg	29,900	30,600	31,000	31,620	31,900	35,950
	lb	65,918	67,461	68,343	69,710	70,327	77,162

GP: General purpose bucket with Liebherr Z140 teeth

HD: Heavy-duty bucket with Liebherr Z140 teeth

XHD: Heavy-duty rock bucket with Liebherr Z140 teeth

Optional equipment

Undercarriage

HD travel gear seal for muddy applications
Undercarriage bottom cover
Rock protection for idler wheel
Travel motor guard with access hatch

Uppercarriage

Banlaw fast fueling system
Fueling system with Multiflo Hydra-Flo®
Wiggins / Banlaw counter plugs for fuel / lube trucks
Swing ring scrapers
Slewing ring with 90° installation arrangement

Hydraulic system

Oil cooler inlet screen

Engine

Fuel consumption optimized engine version (non-certified)
Fuel / water separator
Automatic engine shut down (5 min.)
Cummins Cense™ kit
Cummins Centinel™ kit
Cummins Eliminator™ kit

Cab

4-point seat belt
Additional back and side wipers
Double A/C system
Front protective grid
Auxiliary cab heating system

Attachment

Piston rod guard for bucket cylinder (BH)

Specific solutions

Arctic package (-30 °C / -22 °F, -40 °C / -40 °F, -50 °C / -58 °F)
Sound attenuation package (until +40 °C / +104 °F)
High altitude package

Safety

Automatic fire suppression system

General

Maritime transport packaging

Electric drive

Automatic cable reeler



Mining excavator



Mining truck



Mining dozer



Mining dragline



Service tools



Customer service

Quality commitment

- Liebherr-Mining Equipment Colmar, France, ISO 9001 certified
- Compliance of materials tested in laboratory
- Quality control during all stages of production
- CE certified, MDG 15 & MDG 41 compliant

Subject to technical modifications. All comparisons and claims of performance are made with respect to the prior Liebherr model unless specifically stated.

Liebherr-Mining Equipment Colmar SAS

49 rue Frédéric Hartmann • 68025 Colmar Cedex, France • Phone +33 369 49 20 00
info.lec@liebherr.com • www.liebherr.com • www.facebook.com/LiebherrMining