

EWPh 9670

Built-in multi-temperature wine fridge



Fully Integrated

EWPh 9670

Built-in multi-temperature wine fridge

LIEBHERR

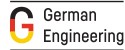

↑
213
↓



Type	Fixed door / Built-in appliance for integrated use
Energy consump. in 365 days/24 h	155 / 0.424 kWh
Max. No. of Bordeaux bottles 0.75 Ltr	100 ¹
Total volume	320 l ²
Climate rating	SN-ST (+10 °C to +38 °C)
Frequency / voltage	50/60 Hz / 220-240 V~
Connection Rating	1.5 A
Door	Isoliertglastür / Stahl
Aperture dimensions in cm (h / w / d)	213.4 / 61 / min. 63.5
Controls	
Type of Control	3.5" LCD colour display, behind the door, touch- & swipe Digital temperature display for 3 wine zones
Alarm in case of malfunction	visual and acoustic
Door alarm	acoustic
Features	
Temperature zones	3
Temperature range	+5 °C to +20 °C
Adjustable cooling circuits	1
Forced air system	Convection cooling, fresh air supply via FreshAir activated charcoal filter
Interior light	InfinityLight
Shelf material	Beech wood fittings
Storage shelves	9
Pull-out shelves on telescopic rails	9
Door hinges	Reversible door hinging, right
EAN-Nr.	9005382276655

¹ These models are only bound for storing wine. Maximum DIN norm bordeaux bottles capacity (0.75 l) as per norm NF H 35-124 (H: 300.5 mm, Ø 76.1 mm)

² In accordance with Regulation EU 2019/2016 we indicate the total volume to the nearest integer (rounded off) and the volume of the frozen compartments and refrigeration compartments to one place after the decimal point.

Features



German Engineering

Our superior products offer premium quality, cutting edge design, and innovative features that best fit your lifestyle. The use of high quality materials, perfectly detailed finishes, and elite cooling components are combined with the latest production processes, resulting in an outstanding cooling product.

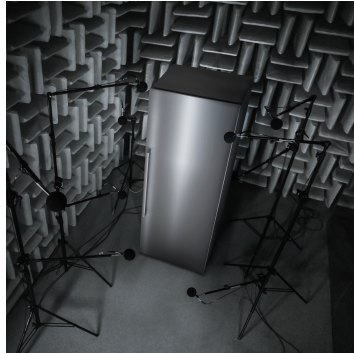

SuperQuiet

Noise levels are kept to a minimum thanks to virtually silent, speed-controlled, and sound absorbing compressors. Alongside a low noise cooling circuit, these features ensure exact performance, energy efficiency, and SuperQuiet operation.



InfinitySwipe

For a touch more comfort, the user-friendly InfinitySwipe electronic touch control with a bright and clear 3.5-inch display can be operated intuitively and effortlessly via touch & swipe.



InfinityLight

Monolith's seamlessly integrated LED side-wall lighting casts a beautiful and even glow that can be adjusted according to taste, including a soft brightening effect upon opening the doors, and a pleasing night dimming feature. InfinityLight doesn't just add drama and flair, it also emits less heat, preserving food quality.



SoftSystem

Thanks to the SoftSystem soft stop mechanism for built-in appliances, the doors close particularly gently and quietly. Depending on its size, the hinges of the Monolith's door panels can bear up to 40 kg (88 lbs) of extra weight.



PowerCooling

The high-performance PowerCooling system from Liebherr ensures that freshly stored groceries are cooled quickly and that the cooling temperature is evenly distributed throughout the interior. In the Monolith, cold air can also circulate behind the door so that food stored in the door stays just as cold as it does in the interior.

Technical drawing

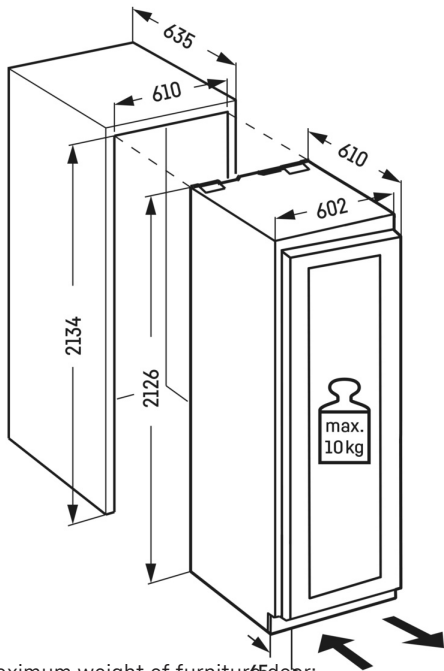

Maximum weight of furniture door:
Fridge compartment: 30 kg

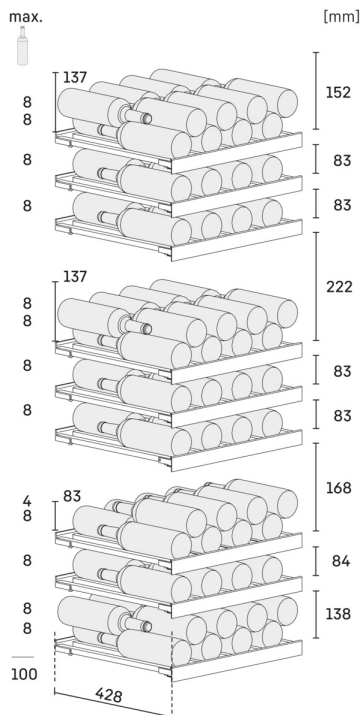

Products and their details are staged for advertising purposes. Whilst every effort is made to ensure all specifications and information in this flyer are accurate, Liebherr reserves the right to make changes without notification. Where actual appliance measurements, specifications, and ratings are crucial, we recommend that the actual appliance installation instructions that accompany each appliance be checked. (21.10.2024)

