

Technical data
Drilling rig

LB 16
Litronic®



LIEBHERR

Concept and characteristics

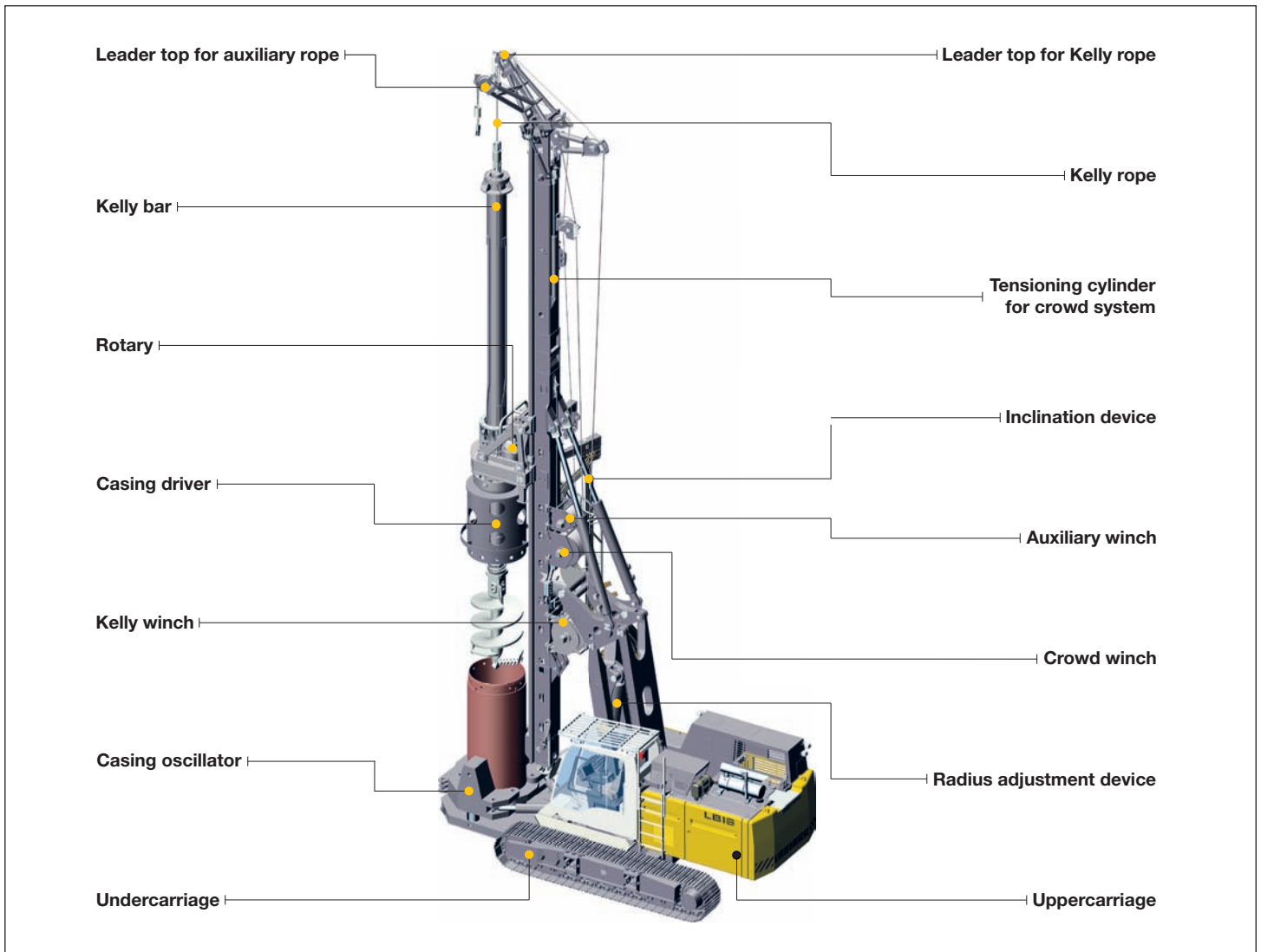

- High engine output with automatic engine speed control
- Controlled entirely from cab
- Sturdy and solid rig design
- Solid parallel kinematics on the basic machine
- High pull and push forces
- High torque
- Completely self-rigging (no auxiliary machines required)
- Large range of working tools (all common drilling operations can be performed)
- Continuous leader inclination 5° forward - 15° backward depending on type of equipment
- Automatic vertical alignment
- High alignment forces
- Simultaneous control of several movements via Load-sensing multi-circuit hydraulics
- Quick assembly of rotary possible through quick connection
- Equipment design according to latest European regulations and standards
- All components designed to fulfill the special requirements of a drilling rig
- High manufacturing quality through quality control by PDE®-system

Dimensions

Basic machine LB 16

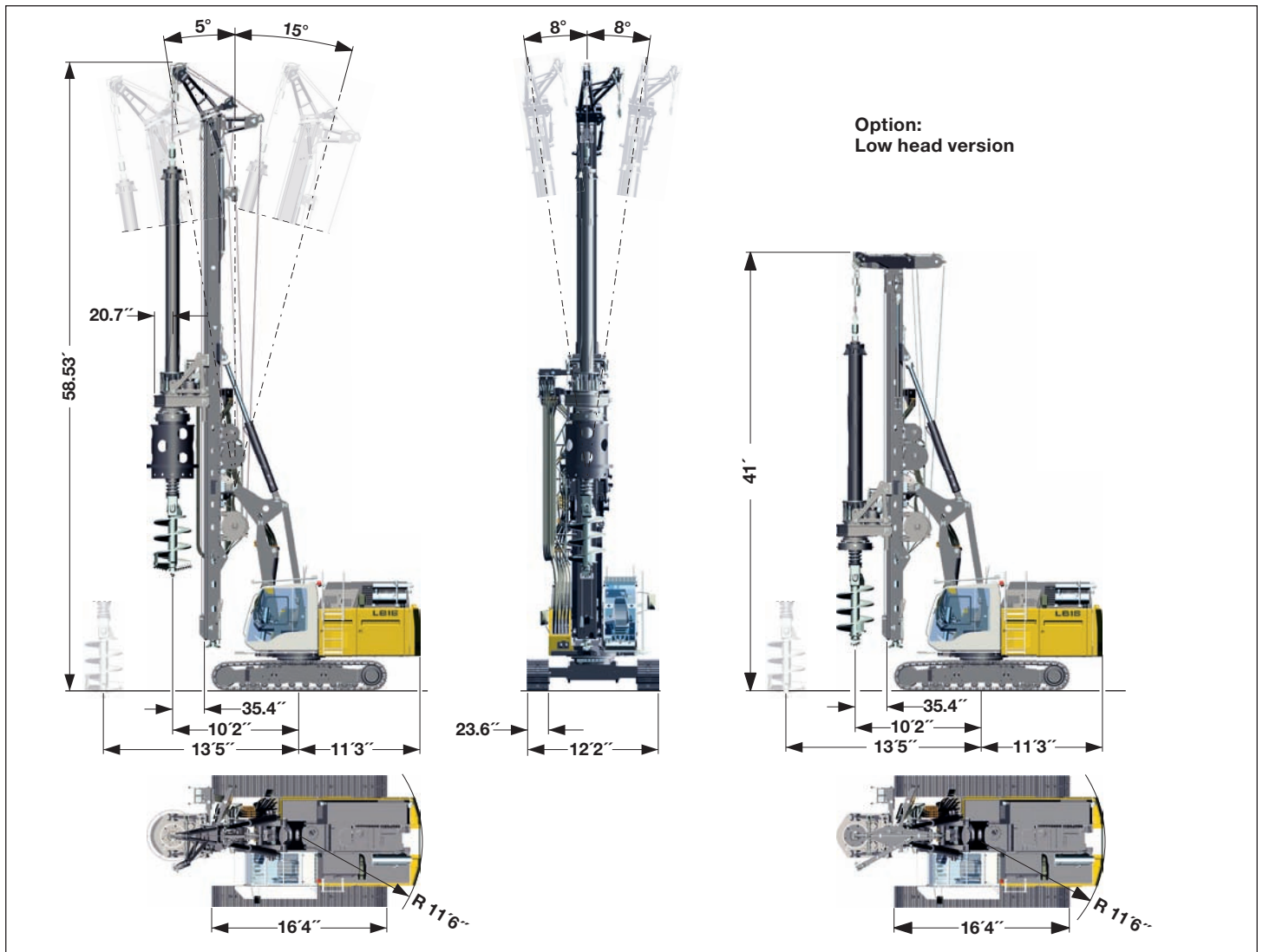

Technical data

Total height	58.53 ft
Max. pull, leader on ground	44,965 lbf
Max. torque	118,747 lbf-ft
Continuous leader inclination	
Lateral inclination	± 8°
Forward inclination	5°
Backward inclination	15°

Operating weight

Total weight — with 23.6 inch 3-web grousers — 114,200 lbs

The operating weight includes the basic machine (with rotary and Kelly bar MD 20/3/24) and 8,820 lbs counterweight, without working tools.

Transport dimensions and weights

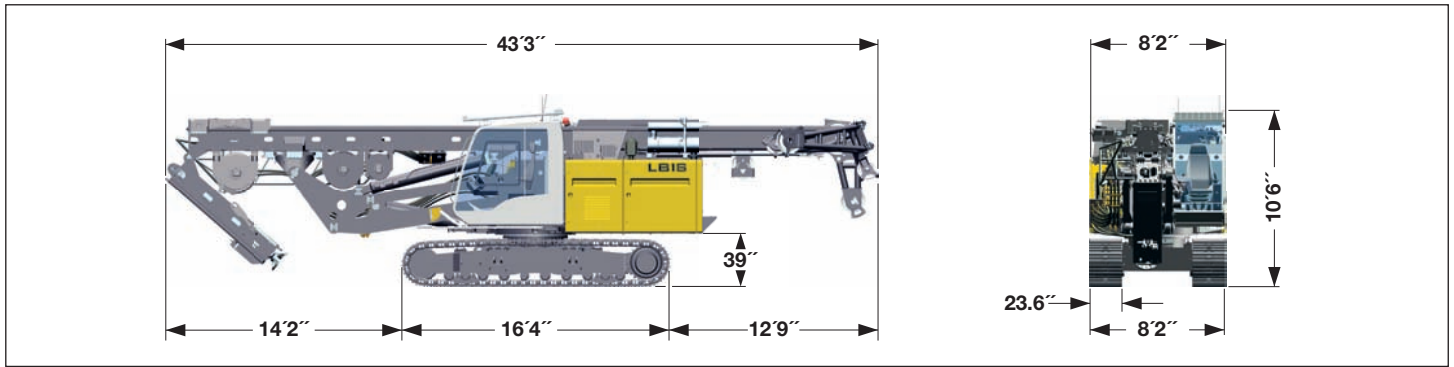

Transport - leader folded

includes the basic machine (ready for operation) with leader, without working tools (such as rotary, Kelly bar etc.) and without counterweight.

Dimensions and weights

Weight complete without counterweight ————— 82,700 lbs

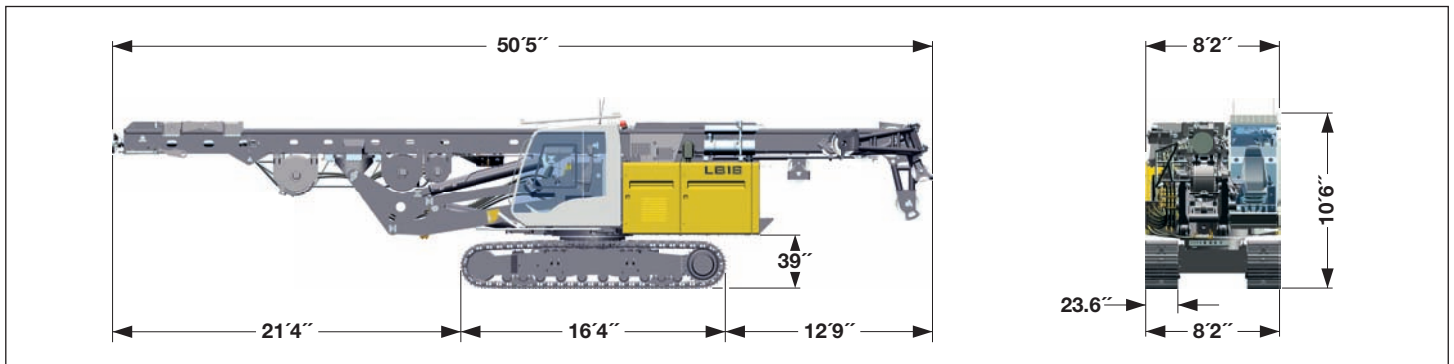

Transport - standard

includes the basic machine (ready for operation) with leader, without working tools (such as rotary, Kelly bar etc.) and without counterweight.

Dimensions and weights

Weight complete without counterweight ————— 82,700 lbs

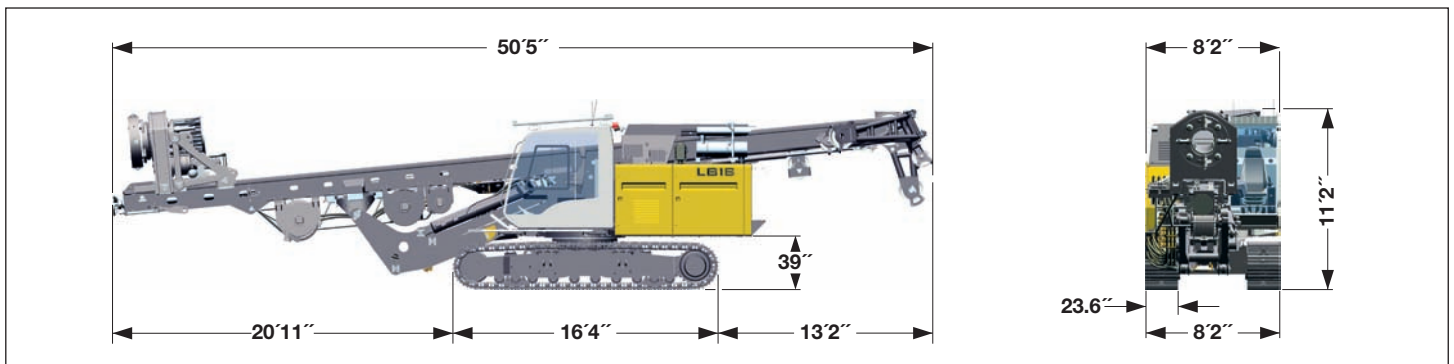

Transport - leader with rotary

includes the basic machine (ready for operation) with leader and rotary, without other working tools (such as Kelly bar etc.) and without counterweight.

Dimensions and weights

Weight complete, with rotary and without counterweight - 93,255 lbs

Transport dimensions and weights

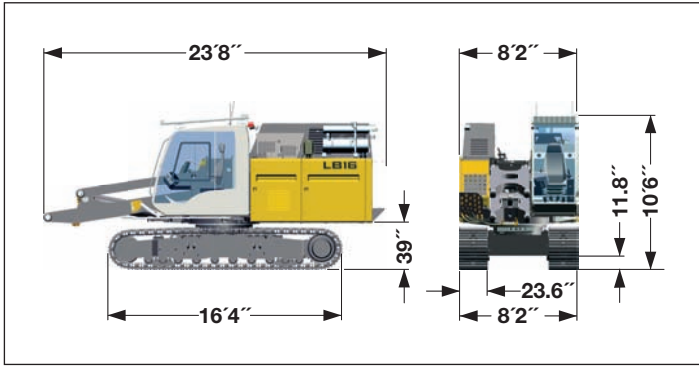

Transport basic machine

ready for operation, without counterweight.

Transport weight ————— 55,115 lbs

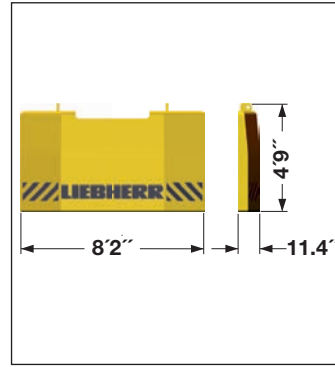

Counterweight

Weight ————— 8,820 lbs

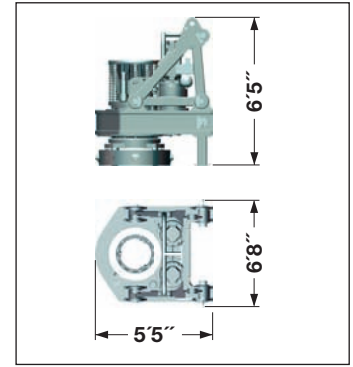

Rotary

Transport weight

BAT 160 ————— 10,475 lbs

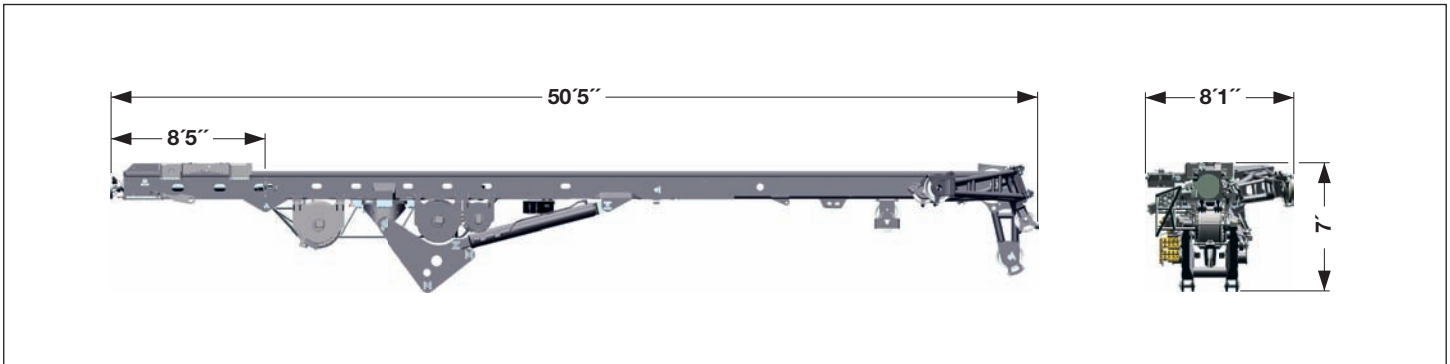

Transport leader

includes the leader without working tools (such as rotary, Kelly bar etc.).

Dimensions and weights

Weight complete ————— 27,560 lbs

Lower part of the leader ————— 2,425 lbs

Upper part of the leader with leader top ————— 4,850 lbs

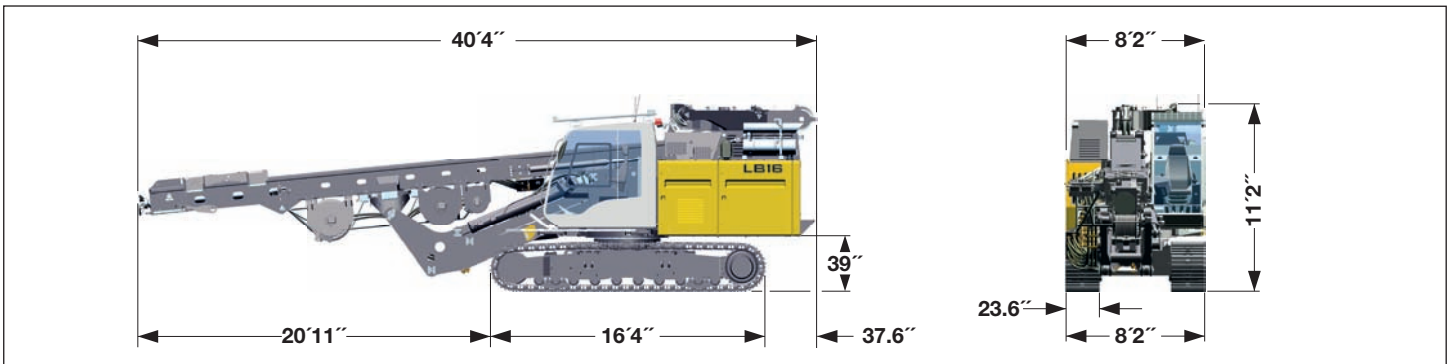

Transport - Low head version

includes the basic machine (ready for operation) with leader, without working tools (such as rotary, Kelly bar etc.) and without counterweight.

Dimensions and weights

Weight complete without counterweight ————— 80,250 lbs

Weights can vary with the final configuration of the machine.

The figures in this brochure may include options which are not within the standard scope of supply of the machine.

Rotary BAT 160 with shock absorber

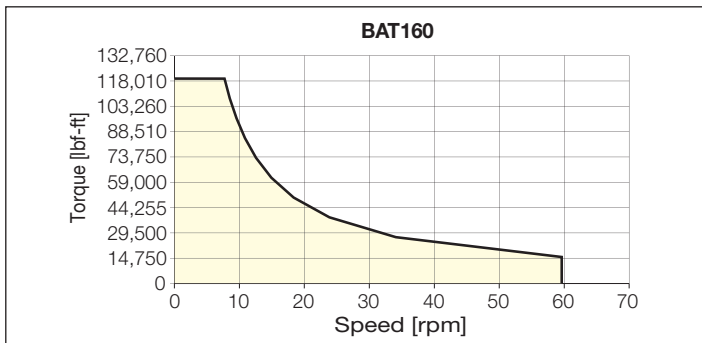
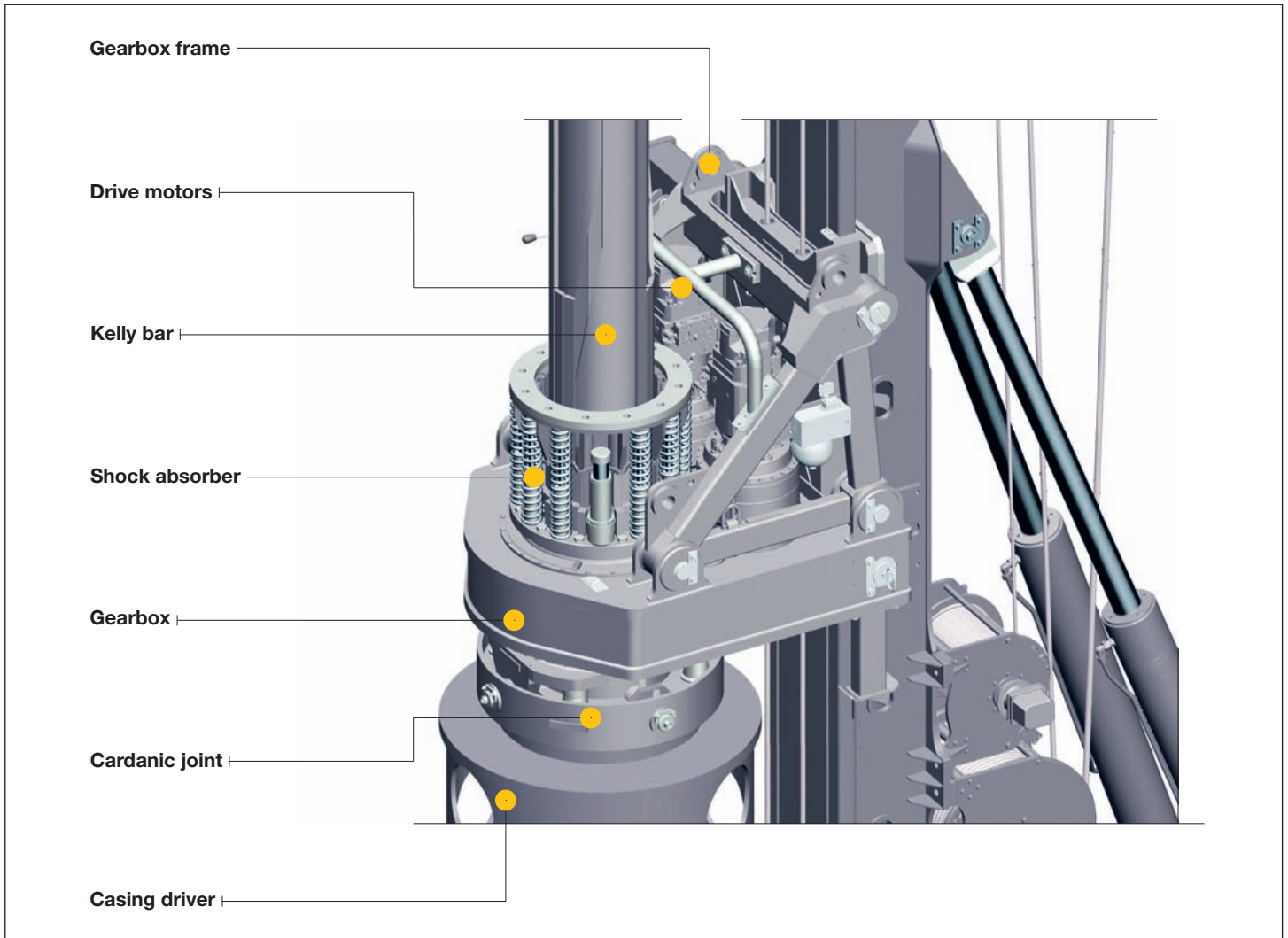

- Continuously variable automatic gearbox for flexible adaptation to soil conditions
- Due to continuous speed control via joystick optimum and precise alignment and rock drilling is possible even at low speed levels; it is not required to preselect an operating mode
- Kelly shock absorber and rubber bearing relieve the material and reduce noise emission
- Thanks to the Kelly shock absorber the Kelly bar is guided at greater length
- Various drive adapters provide compatibility with other systems

Kelly drilling

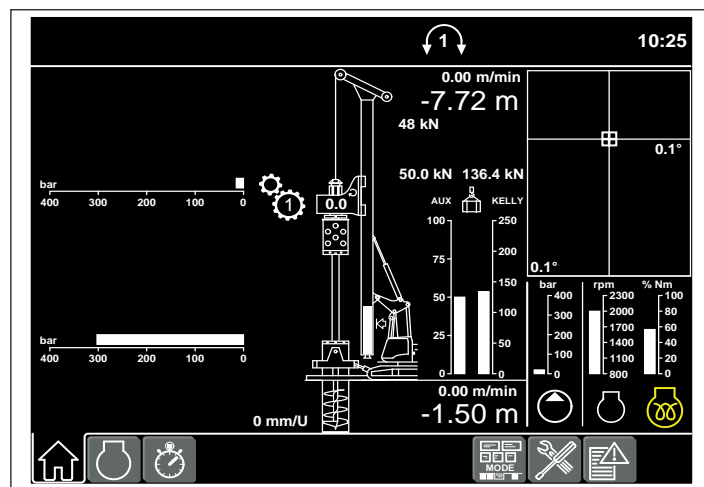
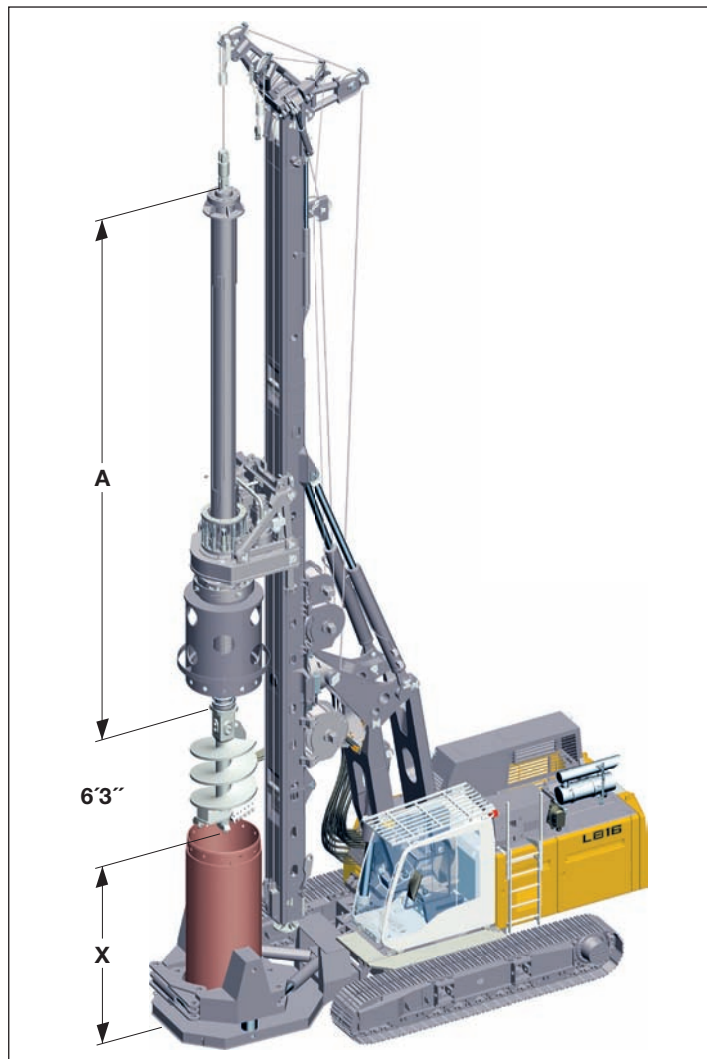

Display for Kelly drilling

Technical data

Drilling drive - torque	0 - 118,750 lbf-ft
Drilling drive - speed	0 - 59.6 rpm

Performance data

Max. drilling diameter*	4.9 ft uncased
Max. drilling diameter*	3.9 ft cased

*) Other drilling diameters available on request.

Other Kelly bars available on request.
When using a casing oscillator, value X has to be reduced by 4.9 ft.

Kelly bars

	A	X	Drilling depth	Weight	Kelly Ø
	(ft)	(ft)	(ft)	(lbs)	(inch)
MD 20/2/18	35.1	8.8	54.1	7,500	14.5
MD 20/3/18	25.6	18.4	54.1	7,500	14.5
MD 20/3/21	28.9	15.1	64.0	8,160	14.5
MD 20/3/24	32.2	11.8	73.8	9,040	14.5
MD 20/3/27	35.4	8.5	83.7	9,920	14.5
MD 20/3/30	38.7	5.2	93.5	10,580	14.5
MD 20/4/36	37.3	6.9	113.2	13,900	14.5

Kelly bars (low head version)

	A	X	Drilling depth	Weight	Kelly Ø
	(ft)	(ft)	(ft)	(lbs)	(inch)
MD 20/3/15	22.3	3.94	44.3	6,610	14.5
MD 20/3/18	25.6	0.65	54.1	7,500	14.5

Continuous flight auger drilling

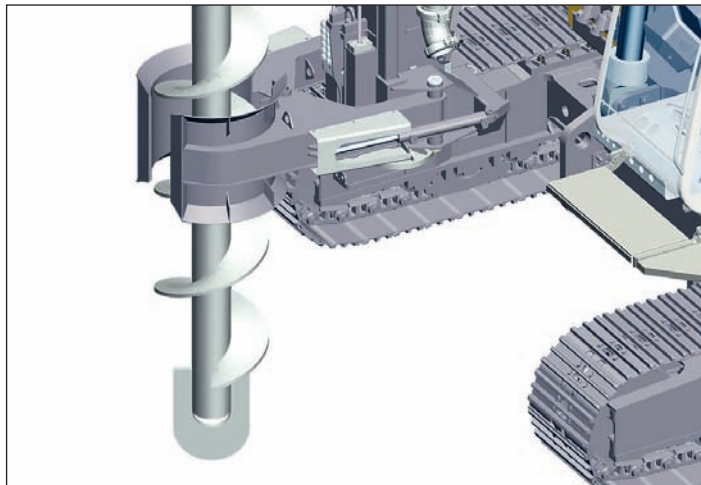

Auger with auger guide

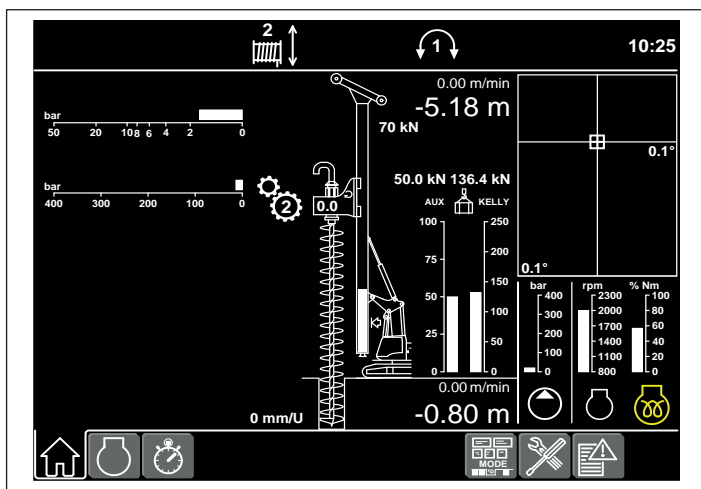

Display for continuous flight auger drilling

Technical data

Drilling drive - torque	0 – 118,750 kNm
Drilling drive - speed	0 – 59.6 rpm

Performance data

Drilling depth with auger cleaner*	35.8 ft
Drilling depth without auger cleaner*	37.7 ft
Drilling depth with 6 m Kelly extension, without auger cleaner	57.4 ft
Max. pull force (crowd winch and Kelly winch)	116,900 lbf
Max. push force (weight of rotary and auger to be added)	29,225 lbf
Max. drilling diameter**	31.5 inch

*) Without Kelly extension

**) Other drilling diameters available on request.

Double rotary drilling

Type DBA 80

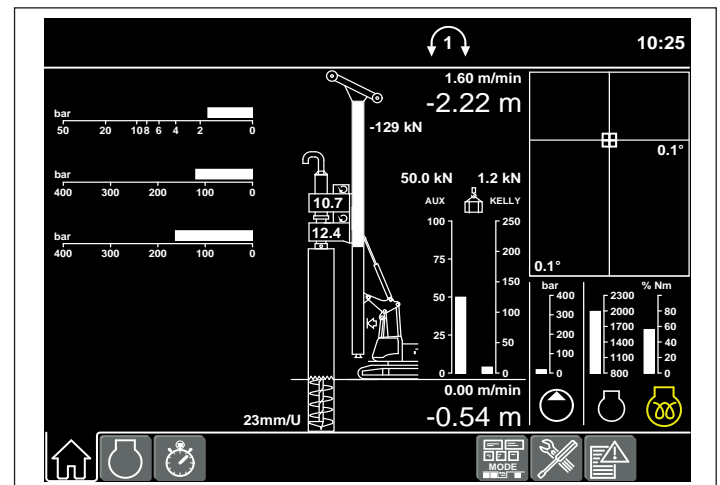

Display for double rotary drilling

Technical data

Drilling drive I - torque	1 st gear	61,220 lbf-ft
Drilling drive I - speed	1 st gear	14 rpm
Drilling drive I - torque	2 nd gear	30,240 lbf-ft
Drilling drive I - speed	2 nd gear	28 rpm
Drilling drive II - torque	1 st gear	45,730 lbf-ft
Drilling drive II - speed	1 st gear	19 rpm
Drilling drive II - torque	2 nd gear	22,865 lbf-ft
Drilling drive II - speed	2 nd gear	38 rpm
Max. drilling diameter*		20 inch
Max. drilling depth		37.7 ft
Max. pull force		112,400 lbf

*) Other drilling diameters available on request.

Single mix equipment

Type MA 35

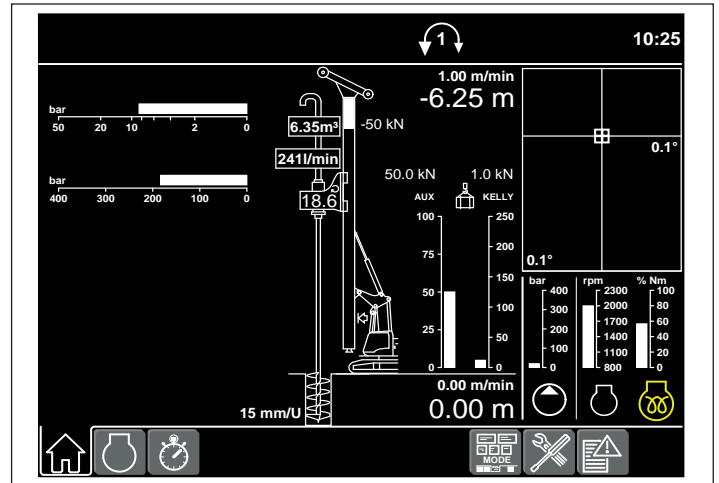

Display for soil mixing

Technical data

Drilling drive - torque	1 st gear	25,814 lbf-ft
Drilling drive - speed	1 st gear	76 rpm
Drilling drive - torque	2 nd gear	12,907 lbf-ft
Drilling drive - speed	2 nd gear	120 rpm
Max. drilling depth		37.7 ft
Max. drilling diameter*		27.6 inch

*) Other diameters available on request.

Technical description



Engine

Power rating according to ISO 9249, 180 kW (241 hp) at 2000 rpm
Engine type ————— Liebherr D 934 L A6
Fuel tank ————— 124 gal capacity with continuous level indicator and reserve warning
Engine complies with NRMM exhaust certification EPA/CARB Tier 3 and 97/68 EC Stage III A.



Hydraulic system

The main pumps are operated by a distributor gearbox. Axial piston displacement pumps work in open circuits supplying oil only when needed (flow control on demand). The hydraulic pressure peaks are absorbed by the integrated automatic pressure compensation, which relieves the pump and saves fuel.

Pumps for working tools ————— 2x 63 gal/min
Separate pump for kinematics ————— 37 gal/min
Hydraulic oil tank ————— 132 gal
Max. working pressure ————— 350 bar

The cleaning of the hydraulic oils occurs via an electronically monitored pressure and return filter. Any clogging is shown on the monitor in the cab. The use of synthetic environmentally friendly oil is also possible.



Crawlers

Propulsion through axial piston motor, hydraulically released spring loaded multi-disc brake, maintenance-free crawler tracks, hydraulic chain tensioning device.

Drive speed of telescopic undercarriage ————— 0 – 1.11 mph
Track force ————— 98,470 lbf
Width of 3-web grousers ————— 23.6 inch
Transport width ————— 8.2 ft



Swing

Swing ring with single row ball bearing, internal teeth and one swing drive, fixed axial piston hydraulic motors, spring loaded and hydraulically released multi-disc holding brake, planetary gearbox and pinion. Selector for 3 speed ranges to increase swing precision.
Swing speed from 0 – 3.5 rpm is continuously variable.



Control

The control system - developed and manufactured by Liebherr - is designed to withstand extreme temperatures and the many heavy-duty construction tasks for which this machine has been designed. Complete machine operating data are displayed on a high resolution monitor. A GSM/GPRS/GPS-modem allows for remote inquiry of machine data and error indications. To ensure clarity of the information on display, different levels of data are shown in enlarged lettering and symbols.
Control and monitoring of the sensors are also handled by this high technology system. Error indications are automatically displayed on the monitor in clear text. The machine is equipped with proportional control for all movements, which can be carried out simultaneously. Two joysticks are required for operation. Pedal control can be changed to hand control.

Options:
• PDE®: Process data recording
• GSM/GPRS/GPS-modem



Kelly winch with freewheeling

Line pull effective (2nd layer) ————— 35,970 lbf
Rope diameter ————— 24 mm
Line speed ————— 0-230 ft/min



Auxiliary winch

Line pull effective (1st layer) ————— 11,240 lbf
Rope diameter ————— 14 mm
Line speed ————— 0-262.5 ft/min



Rope crowd system

Crowd force (push/pull) ————— 44,960/44,960 lbf
Line pull (effective) ————— 122,480 kN
Rope diameter ————— 20 mm
Travel of working tool ————— 39.7 ft
Line speed ————— 0-335 ft/min

The winches are noted for compact, easily mounted design. Propulsion is via a maintenance-free planetary gearbox in oil bath. Load support by the hydraulic system; additional safety factor by a spring-loaded, multi-disc holding brake. All line pull values are effective values. The efficiency factor of approx. 25% has already been deducted.



Noise emission

Noise emissions correspond with 2000/14/EC directive on noise emission by equipment used outdoors.

Process data recording system - PDE® (additional equipment)

The Liebherr process data recording system PDE® constantly records the relevant process data during the working process.

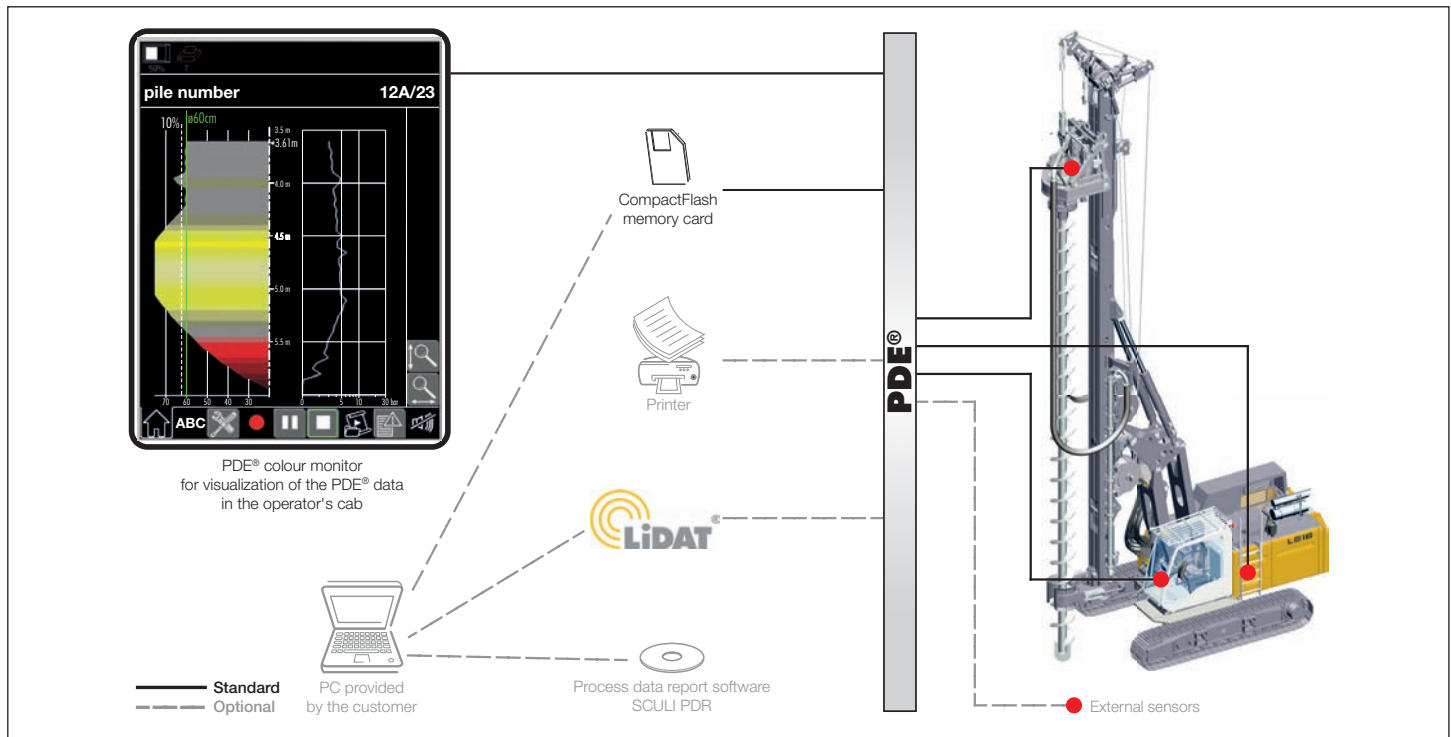

Depending on the application the recorded and processed data are displayed on the PDE® touchscreen in the operator's cab, e.g. in the form of an online cast-in-place pile.

At the same time the PDE® is operated using this touchscreen. The operator can enter various details (e.g. jobsite name, pile number, etc.) and start and stop recordings. A recording of every start-stop cycle carried out in the PDE® is established on a CompactFlash memory card.

The PDE® can be configured in a number of ways, e.g. for the connection of external sensors, for the generation of a simple protocol as graphic file and/or for a printout directly in the operator's cab.

Process data reporting - PDR (additional equipment)

Comprehensive data evaluation and generation of reports on a PC is possible using the software SCULI PDR.

Recordings management - The recordings generated by the PDE® system can be imported and managed in SCULI PDR. The data can be imported directly from the CompactFlash card or via the Liebherr telematics system LiDAT. Certain recordings, e.g. for a particular day or jobsite, can be found using filter functions.

Viewing data - The data in each record is displayed tabularly. Combining several recordings provides results, for example, regarding the total concrete consumption or the average depth. Furthermore, a diagram editor is available for quick analysis.

Generating reports - A vital element of SCULI PDR is the report generator, which allows for the generation of individual reports. These can be printed out directly or stored as pdf files. In the process the size, colour, line thickness or even the desired logo can be configured. Moreover, the reports can be displayed in different languages, e.g. in English and in the national language.

