

LH 40 - LH 50 Industry Litronic

LIEBHERR

Material handling machines

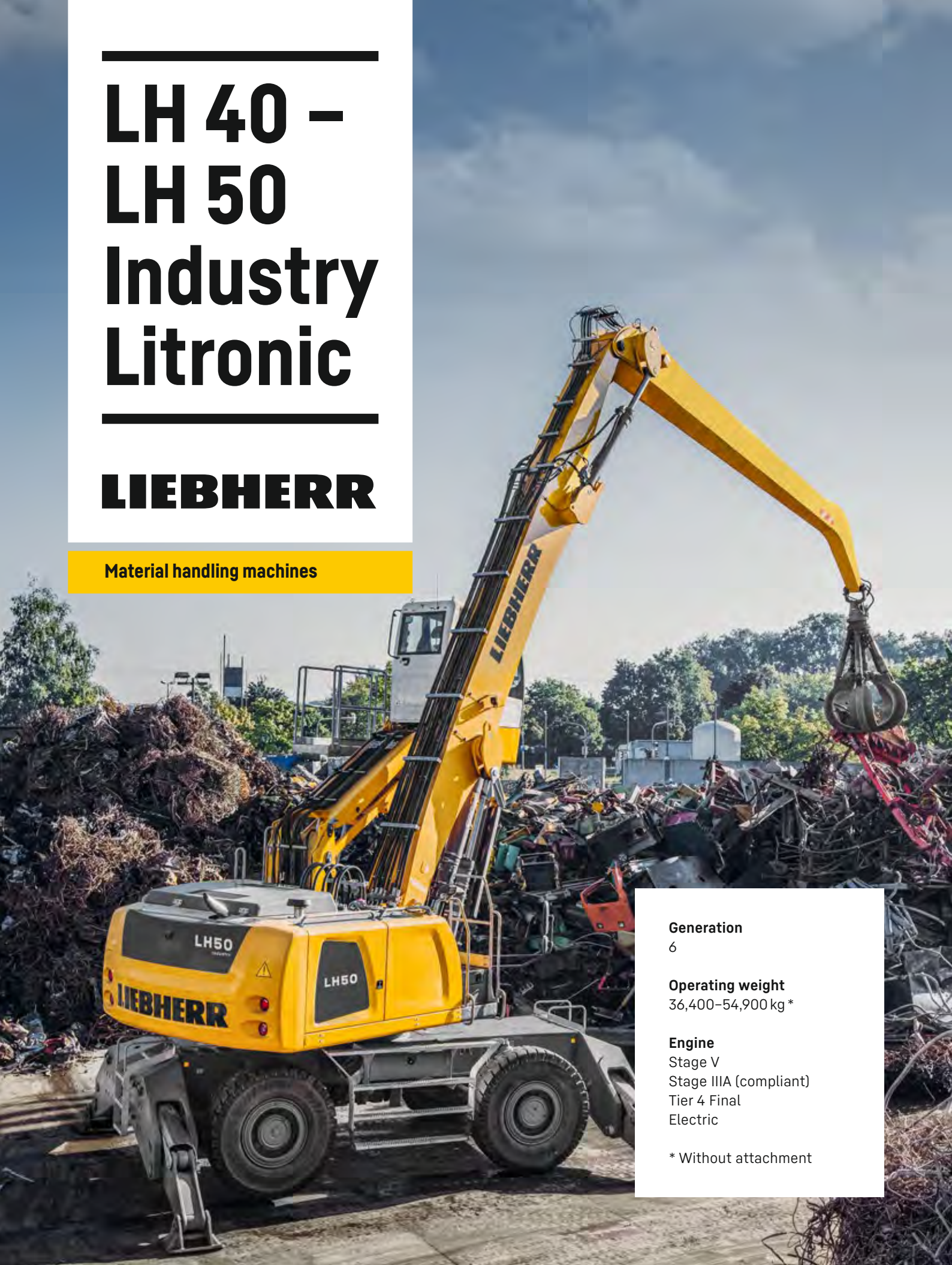

Generation

6

Operating weight

36,400–54,900 kg*

Engine

Stage V
Stage IIIA (compliant)
Tier 4 Final
Electric

* Without attachment

Performance

Power plus speed –
Redefined performance

Economy

Good investment –
Savings for the long-term

Reliability

Durability and sustainability –
Quality down to last detail

Comfort

Perfection at a glance –
When technology is comfortable

Maintainability

Efficiency bonus –
Even with maintenance and service



LH 40 M Industry Litronic

Operating weight
36,400–38,700 kg * 1)

Engine
155 kW / 211 HP (Diesel)
145 kW (Electric)
Stage V
Stage IIIA (compliant)
Tier 4 Final
Electric

System performance
237 kW (Diesel)
227 kW (Electric)

LH 40 C Industry Litronic

Operating weight
37,600–40,900 kg * 1)

Engine
155 kW / 211 HP (Diesel)
145 kW (Electric)
Stage V
Stage IIIA (compliant)
Tier 4 Final
Electric

System performance
237 kW (Diesel)
227 kW (Electric)

* Without attachment

1) Different operating weight
with electric drive



LH 50 M Industry Litronic

Operating weight
40,000–43,500 kg *

Engine
155 kW / 211 HP
Stage V
Stage IIIA (compliant)
Tier 4 Final

System performance
269 kW

LH 50 M High Rise Industry Litronic

Operating weight
46,400–46,900 kg *

Engine
155 kW / 211 HP
Stage V
Stage IIIA (compliant)
Tier 4 Final

System performance
269 kW

LH 50 C High Rise Industry Litronic

Operating weight
53,300–54,900 kg *

Engine
155 kW / 211 HP
Stage V
Stage IIIA (compliant)
Tier 4 Final

System performance
269 kW

Performance



Power plus speed – redefined performance

Liebherr has been designing and manufacturing market leading material handling machines for over 60 years. The generation of Liebherr handlers, the LH 40 and LH 50, are high performance yet economical machines specially designed for use in scrap recycling, in timber yards and also for bulk handling.

Maximum handling capacity

High engine output

Due to the high engine power, the system has a high torque for more powerful, faster movements. Furthermore, the machine automatically compensates for load peaks, meaning full torque is available at all times for maximum handling capacity.

High swing torque

The separate hydraulic pump in the closed slewing circuit only supplies hydraulic fluid to the swing mechanism. The maximum delivery volume is thus available at any time for turning the uppercarriage for fast and dynamic rotational movements.

Energy recovery system ERC

Lowering the equipment in the ERC system provides the machine with additional stored energy. This results in increased system performance, which in turn enables more powerful, faster and more homogeneous work cycles and increases handling performance.

Precision operation

LSC Hydraulic system with electrical pilot control

The 2-circuit Liebherr-Synchron-Comfort-system (LSC) with LUDV technology (flow distribution independent of load pressure) ensures faster working movements with up to 20% less energy consumption.

All work functions of the machine are controlled electrically, whereby the signals of the transmitters are only converted directly at the control block by hydraulic means. This technology enables end position damping of the equipment in order to protect the components and thus extend their service life. Simple, individual setting and adjustment of the working speed of boom, stick and slewing mechanism allow the driver to adjust the machine to each application and fully utilise the machine's capacity.

Firm and stable positioning

An essential prerequisite for precise working and maximum handling capacity is the firm and stable positioning of the machine. The design of the Liebherr undercarriage optimises the way forces are induced on components to minimise stress and guarantee maximum stability and durability.



Liebherr diesel engine

- Powerful, robust and reliable
- Maximum torque even at low speeds to ensure fast movements with low fuel consumption
- Common-Rail injection system for maximum efficiency
- Emissions treatment with Liebherr SCR technology at Stage V



Closed slewing circuit

- High torque for maximum acceleration and fast rotary movements
- Integrated speed sensor for controlling and monitoring braking movement for greater safety
- Greater fuel efficiency thanks to intelligent energy management in the closed system



Electrical pilot control

- Precision control irrespective of the ambient temperature for maximum precision
- Simpler and faster fault diagnostics for optimal availability
- Up to 5 individual driver profiles can be saved

Economy



Good investment – savings for the long-term

Liebherr material handling machines combine high productivity with excellent economy thanks to the use of in-house components as well as sophisticated engine technology and highly efficient demand-controlled hydraulics.

Increased productivity

Engine idling and engine shut-down

The standard automatic idling function reduces the engine speed to idle as soon as the operator takes his hand from the joystick so that no hydraulic function is activated. Proximity sensors in the joystick levers restore the original engine speed as soon as the operator's hand is moved towards the lever again. This ensures that the set engine speed is available immediately. The result is a combination of energy savings and reduced noise levels. Operating costs can be reduced even further with the optional automatic engine shut down function.

Closed hydraulic circuit for the swing mechanism

The closed slewing circuit feeds the braking energy back into the system when the uppercarriage is braked. Here, new standards are set in terms of efficiency and economy. Simple yet effective.

Attachments and quick coupling systems

Liebherr offers a wide selection of attachments for every application to increase the productivity of its material handling machines. In addition the material handlers can be fitted with a Liebherr quick coupling system which increase the productivity of the machine by up to 30%. The matching attachment and quick coupling system combined with the outstanding dynamics of a Liebherr handler ensures highest handling capacity and maximum productivity.

Electrical efficiency

Electric drive concept

The electric drives offer an economical and sustainable solution in the field of material handling. The drive motors operate in an environmentally friendly and emission-free manner, which makes them independent of any exhaust emission standards. A significant reduction in operating and service costs is achieved due to the elimination of maintenance work such as oil changes and fuelling breaks, as well as longer service intervals compared to diesel models. This increase in efficiency results in optimal working times and increased productivity in the field. In addition, the low-vibration and low-noise operation ensures improved working comfort.

Sustainable profitability with electric machines

An investment in an electric material handling machine pays off in the long term. These advanced drives offer numerous advantages that enable fast amortisation of the machine and significant cost savings compared to conventional diesel engines. Given the growing importance of environmental criteria and emissions, electric drives are an economical alternative that ensures both sustainable profitability and environmentally friendly operation.

Liebherr Power Efficiency (LPE) System

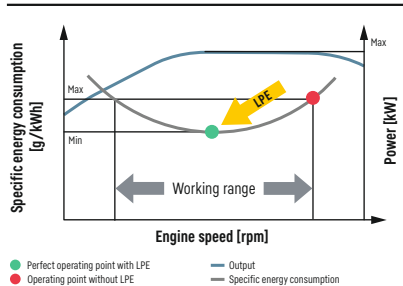

Low energy consumption thanks to intelligent machine control

- Liebherr-Power Efficiency (LPE) optimises the interaction of the drive components in terms of efficiency
- LPE enables machine operation in the area of the lowest specific energy use for less consumption and greater efficiency with the same performance

Liebherr-attachments

- Robust and service-friendly slewing drive, can be turned 360°
- Optimum filling and clamping performance for effective material handling
- Finite element method (FEM) optimised for a perfect relationship between grapple weight, volume and a very long service life

Frequency converters

- Individual adjustment of the speed
- Smooth start-up to avoid inrush current peaks and high energy savings due to effective start-up current limitation
- Simple adjustment to all conventional power supply networks

Reliability



Durability and sustainability – quality down to the last detail

Every day Liebherr material handlers demonstrate their qualities in a range of industrial applications all over the world. Years of experience, continuous development and the latest technologies provide maximum safety in use. Their robust design and the use of components produced in-house ensure that the LH 40 and LH 50 are designed for a long service life.

More safety

Pipe fracture safety valves

The standard pipe fracture safety valves on the stick and hoist cylinders prevent the equipments from dropping in an unregulated way and ensure maximum safety during every operation.

Working range limiters

For operations in which the working range should be limited, the material handling machines can be optionally equipped with a working range limitation feature. Collisions and resulting component damage can thus be avoided.

Overload warning device and load torque limitation

The audible and visual overload warning system continuously tells the operator about the current load situation of the machine. Furthermore, load torque limitation automatically regulates the speed of the working hydraulics to allow the maximum load bearing capacity to be approached safely. In the event of an overload, the functions which could cause the machine to topple are disabled. Only movements back to the safe working range are then possible.

High machine availability

Quality and competence

Our experience, understanding of customer needs and the technical implementation of these findings guarantee the success of our products. For decades, Liebherr has been inspirational with its depth of production and system solutions. Key components such as the diesel engine, electronic components, slew ring, swivel drive and hydraulic cylinders are developed and produced by Liebherr itself. The extent of in-house manufacturing guarantees maximum quality and ensures that components are optimally configured to each other.

Robust design

All steel components are designed and manufactured by Liebherr. High-strength steel plates configured for the toughest of requirements result in high torsional stiffness and optimum absorption of forces induced for a longer service life.

Intelligent self diagnostics

The innovative control electronics permanently monitor the vital functions of the machine to guarantee a high level of machine availability. Components which are critical for safety are designed with redundancy to guarantee maximum reliability.



QPDM – Quality and process data management

- QPDM allows production data to be logged, documented and evaluated
- Automation of documentation and test specifications
- Ability to handle large quantities of data while maintaining uniform high quality



Piston rod protection

- Maximum protection of piston rod
- Robust construction of hot-dip galvanized steel for a long service life in tough applications
- Available for outriggers, hoist cylinders, ERC cylinder and tip cylinder as an option



Equipment

- Components enhanced using FEM for maximum service life even if subjected to heavy lateral stresses during demanding tasks
- Cables routed internally to protect them from damage
- High load capacities with long reaches
- Reaches up to 19m

Comfort



Perfection at a glance – when technology is comfortable

The Liebherr deluxe cab is spacious, has an ergonomic design and is very quiet. This ensures that the operator is able to fully focus throughout the working day.

Deluxe cab

Ergonomic design

The cab design provides excellent conditions for healthy, focussed and productive work in maximum comfort. The colour touchscreen display, the controls and operator's Comfort seat are all coordinated to form a perfect ergonomic unit. In addition the ergonomic joysticks allow the machine operation to be both pleasant and precise.

Excellent all-round vision

The large areas of glass, different versions of cab elevations and the rear and side area monitoring systems provide the operator with an excellent view of their working area and the zone around the machine. This perfect view enhances the operator's safety and ensures that they can handle the machine safely at all times.

Low noise levels

The use of viscoelastic mounts, good insulation and low noise diesel engines from Liebherr minimises noise emissions and vibrations. Both electric and diesel-powered machines produce extremely low sound levels, which means they are classed as low-noise machines that are not harmful to people and the environment.

Comfortable operation

Proportional control

Precision control of the material handling machine is especially important in applications such as waste separation or scrap recycling. Thanks to the standard proportional control, even such demanding operations can be mastered with ease.

Joystick steering and stabilizing

The standard joystick steering gives the operator an additional comfort boost. The steering movement can be conveniently executed using the joystick, eliminating the need to reposition during the work cycle. Substituting the steering wheel in favour of joystick steering provides additional legroom and a clear view of the working area. A standard feature is the control of the outriggers with the joystick for more comfort and an increased productivity of the machine.

Colour touchscreen display and operation unit

The 9" colour touchscreen display is intuitive in its operation and provides continuous information about all important operating data. The shortcut keys can be individually assigned and are selected quickly and easily with the menu strip.

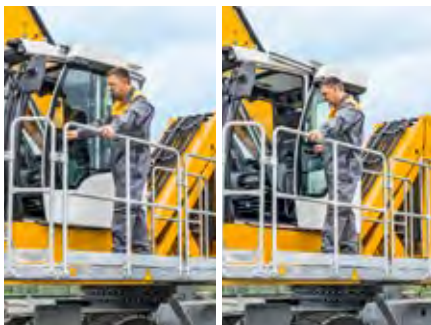

Safe access

- Foldable left arm console as well as wide, non-slip steps, catwalks and platforms, and ergonomically positioned handles for easy and safe access
- All access systems are designed to national guidelines and statutory regulations
- Sliding door for comfortable entry with narrow platforms is available as an option



Comfort operator's seat with adjustable armrests

- Greater seating comfort due to variable damper hardness, lockable horizontal suspension, pneumatic lumbar support, seat heating and passive seat air conditioning for concentrated working
- Individual adjustment options for armrests, seat cushion depth, seat angle and head restraint for comfortable working



Joystick with proportional control

- Good functionality with streamlined, ergonomic design
- 4-way mini joystick can be used to control all operations e.g. steering, outriggers and attachments etc.
- Joysticks - each with two buttons and a rocker switch - increase the number of functions available

Maintainability



Efficiency bonus – even with maintenance and service

The Liebherr LH 40 and LH 50 material handling machines are powerful, robust, precise and efficient. They also feature integral maintenance benefits as a result of their service-based machine design. All maintenance work for Liebherr material handlers can be carried out quickly, easily and safely. This minimises the machine's maintenance costs and downtime.

Efficient maintenance concept

Service-based machine design

The service-based machine design guarantees short servicing times, thus minimising maintenance costs. All the service points are positioned in close proximity to one another, are easily accessible from the ground or from catwalks and platforms, and easy to reach thanks to the large, wide-opening service doors. This means that service work can be completed even more quickly and efficiently.

Integral maintenance benefits

Maintenance work helps to keep the machine fully functional. However this kind of work leads to machine downtimes which have to be minimised. With change intervals of up to 2,000 hours for engine oil and up to 8,000 hours for hydraulic oil, Liebherr has significantly reduced the amount of maintenance and increased the productivity of the material handlers. In addition, central lubrication systems minimise daily maintenance. Above all, electric material handling machines are characterised by their low maintenance requirements.

Your competent service partner

Remanufacturing

The Liebherr remanufacturing program offers cost-effective reconditioning of components to the highest quality standards. Various reconditioning levels are available: Replacement components, general overhaul or repair. The customer receives components with original part quality at a reduced cost.

Competent advice and service

Competent advice is a given at Liebherr. Experienced specialists provide decision guidance for your specific requirements: application-oriented sales support, service agreements, economical repair alternatives, original parts management, as well as remote data transmission for machine planning and fleet management.

Fast spare parts service

The Liebherr spare parts service provides 24-hour delivery and is therefore available to our dealers around the clock. Thanks to the electronic spare parts catalogue the parts can be selected and ordered quickly and reliably using the Liebherr online portal. Your order can be tracked at any time using the online tracking system.



Lubrication as it works

- Fully automatic central lubrication system for uppercarriage and equipment
- Fully automatic central lubrication system for the undercarriage and attachments available as an option
- Lubricates without interrupting work to ensure better productivity and a long component service life



Servicing advantages for electrical machines

- Low operating and maintenance costs
- Significantly longer maintenance intervals compared to diesel engines due to a lower number of wear parts
- Cost savings on servicing
- Maximum productivity due to permanent readiness of the machine



SCRFilter for stage V

- The SCR filter system developed by Liebherr includes a DOC catalyst, an SCR catalyst and an SCR-coated particulate filter
- The DOC catalyst requires no maintenance and the coated particulate filter is regenerated passively
- The maintenance intervals can be extended to more than 4,500 operating hours

Material handling machines overview

Equipment

- High load capacities and long reaches thanks to optimised kinematic properties and robust construction for greater handling performance
- Energy recovery cylinder filled with nitrogen for maximum efficiency through less energy consumption at more handling capacity
- Pipe fracture safety valves on hoist and stick cylinders and retract stick shut-off for maximum safety during every application
- Quick coupling systems and attachments made by Liebherr for maximum machine capacity utilisation and greater handling performance

Operator's cab

- Joystick steering without steering column as standard for convenient operation, greater legroom and clear view of the working area
- Less strain on the operator, workers and reduced environmental pollution due to lower noise emissions
- Optimum visibility thanks to large glass surfaces and standard rear and side area monitoring with camera
- Proportional control as standard with 4-way mini joystick for greater precision, high precision control and functions





Uppercarriage

- 2-circuit Liebherr-Synchron-Comfort-system (LSC) with LUDV technology for faster working speed at up to 20% less energy consumption
- 155 kW engine output and greater pump flow for fast work cycles and maximum handling performance
- Electrical pilot control enables individual settings for the operator and an end position damping of the equipment
- Reduction in operating costs thanks to built-in maintenance advantages and optimum service accessibility
- Frequency converter provides the direct energy supply and control for the electric motor*

Undercarriage

- Optimised hydraulics with closed slewing mechanism circuit for greater energy efficiency and faster work cycles
- Central lubrication system (manual/ fully automatic) for more productive working time (optional available)
- Load-holding valves fitted as standard on all support cylinders for maximum stability in every application
- Less downtimes thanks to maintenance-free support cylinders
- Different cable variants for flexible applications and high mobility*

* only with electric

The perfect solution for every application

Attachments

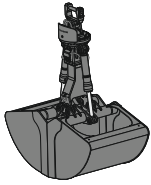

Grab for loose material

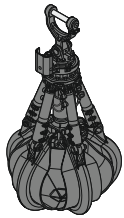

Multi-tine grab

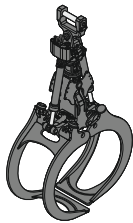

Wood grab

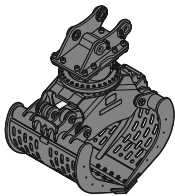

Sorting grab

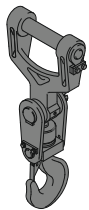

Load hook

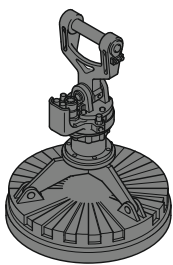

Magnet plate

Sticks

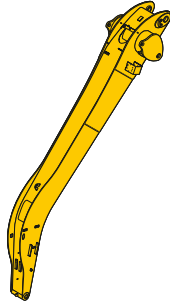

Angled stick

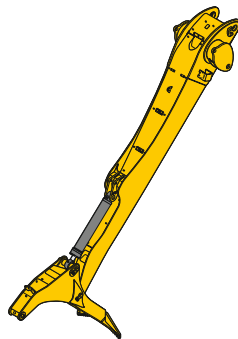

Stick with counterstay

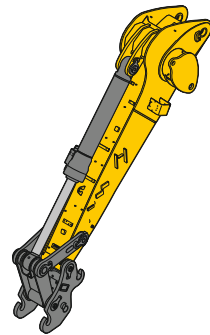

Stick for scrap shear

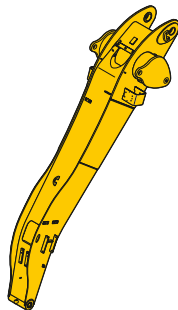

Flat angled stick

Booms

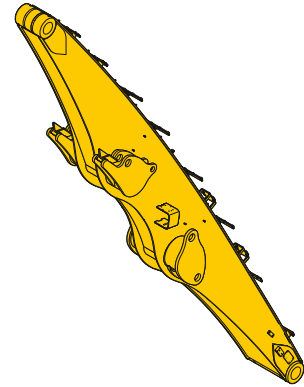

Straight boom

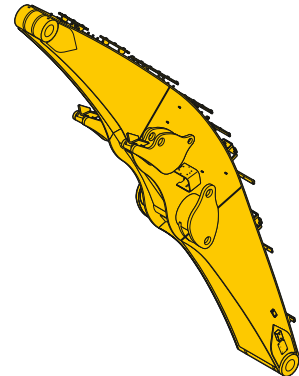

Angled boom

Cab elevations

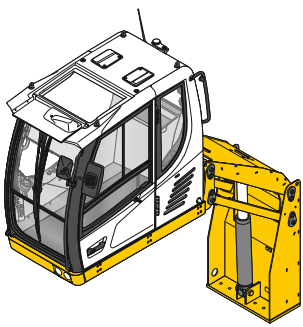

Hydraulic cab elevation



30° tilt function

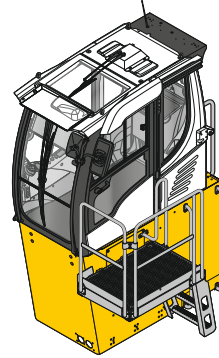

Rigid cab elevation

Uppercarriage

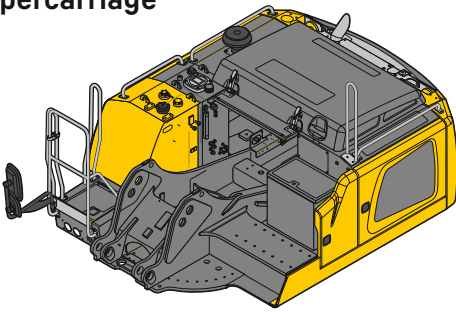

Diesel

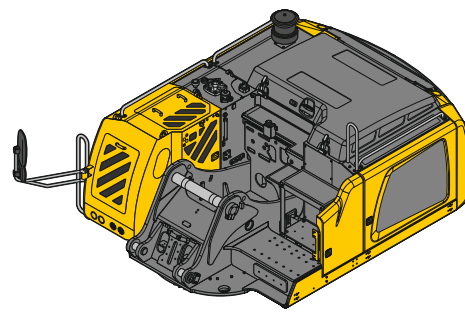

Electric

Turret elevations

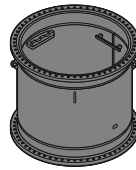

Undercarriage

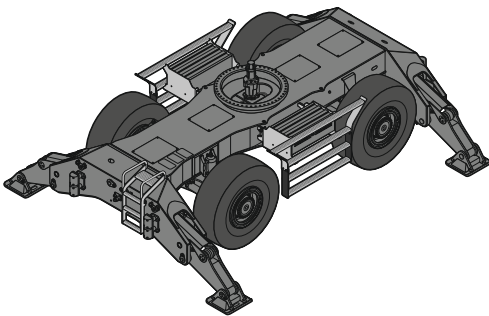

Mobile

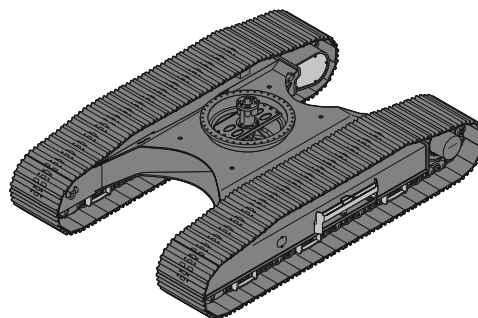

Crawler

Examples of use



LH 50 M Industry Litronic in scrap handling operation



Container dismantling with the LH 40 M Industry Litronic



LH 50 M Industry Litronic in trailer operation when handling logs



Scrap handling with the LH 50 M Industry Litronic



Loading extruded aluminium bundles onto wagons with the LH 50 M Industry Litronic



Loading a concrete mixing plant with the LH 40 M Industry Litronic



LH 50 C High Rise Industry Litronic loading waste wood



LH 40 M Industry Litronic for disassembling steel girders with a scrap shear

Technical data

Diesel engine

Rating per ISO 9249	155 kW (211 HP) at 1,800 RPM
Model	Liebherr D934
Type	4 cylinder in-line
Bore / Stroke	122 / 150 mm
Displacement	7.0 l
Engine operation	4-stroke diesel Common-Rail Turbo-charged and after-cooled Reduced emissions
Air cleaner	Dry-type air cleaner with pre-cleaner, primary and safety elements
Engine idling	Sensor controlled
Electrical system	
Voltage	24 V
Batteries	2 x 180 Ah / 12 V
Alternator	Three-phase current 28 V / 140 A
Stage V	
Harmful emissions values	According to regulation (EU) 2016/1628
Emission control	Liebherr-SCR Filter technology
Fuel tank	453 l
Urea tank	65 l
Stage IIIA (compliant)	
Harmful emissions values	In accordance with ECE-R.96 Power Band H
Fuel tank	453 l
Tier 4 Final	
Harmful emissions values	In accordance with 40CFR1039 (EPA) / 13CCR (CARB)
Emission control	Liebherr-SCR technology
Fuel tank	453 l
Urea tank	65 l

Electric motor

Rating	145 kW at 1,800 RPM
Type	Three-phase squirrel cage motor
Secondary electric motor	Electric motor auxiliary equipment (air-conditioning compressor, alternator 24 V) 15 kW
Electrical system energy supply	Frequency converter fed drive system Heavy-duty version
Supply voltage	
Low voltage	380 V, 400 V
Frequency	50 / 60 Hz
Engine idling	Sensor controlled
Electrical system	Battery-assisted Control system, lighting, diagnostics system 24 V
Voltage	24 V
Batteries	2 x 135 Ah / 12 V
Alternator	Three-phase current 28 V / 140 A

Deviating parameters of the power supply system must always be clarified with Liebherr-Hydraulikbagger GmbH.

Cooling system

Diesel engine	Water-cooled Compact cooling system consisting cooling unit for water, hydraulic oil and charge air with stepless thermostatically controlled fan
Electric motor	Air-cooled Cooling system for hydraulic oil with an infinitely variable, thermostatically controlled fan drive system

Hydraulic controls

Power distribution	Via control valves with integrated safety valves, simultaneous actuation of chassis and equipment. Swing drive in separate closed circuit
Servo circuit	
Equipment and swing	With electro-hydraulic pilot control and proportional joystick levers
Chassis mobile	Electro-proportional via foot pedal
Chassis crawler	With electric proportionally functioning foot pedals or adjusted with plugable levers
Additional functions	Via switch or electro-proportional foot pedals
Proportional control	Proportionally acting transmitters on the joysticks for additional hydraulic functions

Hydraulic system

Hydraulic pump	
For equipment and travel drive	2 Liebherr axial piston variable displacement pumps (double construction)
Max. flow	2 x 237 l/min.
Max. pressure	350 bar
For swing drive	Reversible axial piston variable displacement pump, closed-loop circuit
Max. flow	144 l/min.
Max. pressure	370 bar
Hydraulic pump regulation and control	2 circuit Liebherr-Synchron-Comfort-system (LSC) with electronic engine speed sensing regulation, pressure and flow compensation, automatic oil flow optimizer
Hydraulic tank	285 l
Hydraulic system	605 l
Filtration	1 main return filter with integrated partial micro filtration (5 µm)
MODE selection	Adjustment of engine and hydraulic performance via a mode pre-selector to match application, e.g. for especially economical and environmentally friendly operation or for maximum material handling and heavy-duty jobs
S (Sensitive)	Mode for precision work and lifting through very sensitive movements
E (Eco)	Mode for especially economical and environmentally friendly operation
P (Power)	Mode for high performance with low fuel consumption
P+ (Power-Plus)	Mode for highest performance and for very heavy duty applications, suitable for continuous operation
Engine speed and performance setting	Stepless alignment of engine output and hydraulic power via engine speed
Option	Tool Control: 20 pre-adjustable pump flows and pressures for add-on attachments

Swing drive

Drive	Liebherr axial piston motor in a closed system, Liebherr planetary reduction gear
Swing ring	Liebherr, sealed race ball bearing swing ring, internal teeth
Swing speed	0-7.5 RPM stepless (LH 40) 0-8.0 RPM stepless (LH 50) 0-6.5 RPM stepless (High Rise)
Swing torque	84 kNm
Holding brake	Wet multi-disc (spring applied, pressure released)
Option	Slewing gear brake Comfort

Cab

Cab	TOPS safety cab structure (tip-over protection) with individual windscreens or featuring a slide-in subpart under the ceiling, work headlights integrated in the ceiling, a door with a sliding window (can be opened on both sides), large stowing and depositing possibilities, shock-absorbing suspension, sound damping insulating, tinted laminated safety glass, separate shades for the sunroof window and windscreen
High Rise	Deviating from standard: safety cab structure with fixed built-in front and roof window made from impact-resistant laminated safety glass
Operator's seat Comfort	Air cushioned operator's seat with 3D-adjustable armrests, headrest, lap belt, seat heater, adjustable seat cushion inclination and length, lockable horizontal suspension, automatic weight adjustment, adjustable suspension stiffness, pneumatic lumbar vertebrae support and passive seat climatisation with active coal
Operator's seat Premium (Option)	In addition to operator's seat comfort: active electronic weight adjustment (automatic readjustment), pneumatic low frequency suspension and active seat climatisation with active coal and ventilator
Arm consoles	Joysticks with control consoles and swivel seat, folding left control console
Operation and displays	Large high-resolution operating unit, self-explanatory, colour display with touchscreen, video-compatible, numerous setting, control and monitoring options, e.g. air conditioning control, fuel consumption respectively energy consumption, machine and attachment parameters
Air-conditioning	
Diesel engine	Automatic air-conditioning, recirculated air function, fast de-icing and demisting at the press of a button, air vents can be operated via a menu; recirculated air and fresh air filters can be easily replaced and are accessible from the outside; heating-cooling unit, designed for extreme outside temperatures, sensors for solar radiation, inside and outside temperatures
Electric motor	In addition to diesel engine: stationary air conditioning function with external climate condenser - controlled by a weekly timer
Refrigerant	R134a
Global warming potential	1,430
Quantity at 25 °C*	1,400-1,600 g (Diesel) 1,500-1,800 g (Electric)
CO ₂ equivalent*	2.002-2.288 t (Diesel) 2.145-2.574 t (Electric)
Vibration emission**	
Hand / arm vibrations	< 2.5 m/s ²
Whole-body vibrations	< 0.5 m/s ²
Measuring inaccuracy	According with standard EN 12096:1997

Equipment

Type	High-strength steel plates at highly-stressed points for the toughest requirements. Complex and stable mountings of equipment and cylinders
Hydraulic cylinders	Liebherr cylinders with special sealing and guide system and, depending on cylinder type, shock absorption
Energy recovering cylinder	Liebherr gas cylinder with special sealing and control system
Bearings	Sealed, low maintenance

* depending on configuration

** for risk assessment according to 2002/44/EC see ISO/TR 25398:2006

Undercarriage

Mobile	
Versions	Standard, High Rise
Drive	Oversized two speed power shift transmission with additional creeper speed, Liebherr axial piston motor with functional brake valve on both sides
Travel speed	0- 3.0 km/h stepless (creeper speed + transmission stage 1) (Diesel)
Joystick steering	0- 2.4 km/h stepless (creeper speed + transmission stage 1) (Electric) 0- 5.0 km/h stepless (transmission stage 1) 0-12.0 km/h stepless (creeper speed + transmission stage 2) 0-12.0 km/h stepless (transmission stage 2)
Travel speed	0- 3.0 km/h stepless (creeper speed + transmission stage 1) (Diesel)
Wheel steering (Option)	0- 2.4 km/h stepless (creeper speed + transmission stage 1) (Electric) 0- 5.0 km/h stepless (transmission stage 1) 0-12.0 km/h stepless (creeper speed + transmission stage 2) 0-12.0 km/h stepless (transmission stage 2, only for High Rise) 0-20.0 km/h stepless (transmission stage 2, not for High Rise)
Driving operation	Automotive driving using accelerator pedal, cruise control function: storage of variable accelerator pedal positions
Axles	60 t / 70 t drive axles (LH 40 M / LH 50 M); manual or automatic hydraulically controlled front axle oscillation lock
Option	Four wheel steering (LH 40 M)
Option	Steering reversal control (LH 40 M)
Service brake	Two circuit travel brake system with accumulator; wet and backlash-free disc brake
Holding brake	Wet multi-disc (spring applied, pressure released)
Stabilization	4 point outriggers
Option	Dozer blade, at the front, for 4 point outriggers (not for High Rise)
Crawler	
Versions	EW, SW, High Rise
Drive	Liebherr compact planetary reduction gear with Liebherr axial piston motor per side of undercarriage
Travel speed	
EW (LH 40)	0-4.4 km/h stepless 0-3.0 km/h stepless (creeper speed)
SW (LH 40)	0-3.9 km/h stepless 0-2.4 km/h stepless (creeper speed)
High Rise (LH 50)	0-3.7 km/h stepless 0-2.3 km/h stepless (creeper speed)
Brake	Functional brake valves on both sides
Holding brake	Wet multi-disc (spring applied, pressure released)
Track pads	Triple grouser, flat
Tracks	Sealed and greased

Complete machine

Lubrication	Liebherr central lubrication system for uppercarriage and equipment, automatically
Mobile (Option)	Liebherr central lubrication system for undercarriage, automatically
Steps system	Safe and durable access system with anti-slip steps; main components hot-galvanised
Noise emission	
ISO 6396	70 dB(A) = L _{PA} (inside cab)
2000/14/EC	103 dB(A) = L _{WA} (surround noise)

LH 40 M – Dimensions

Industry

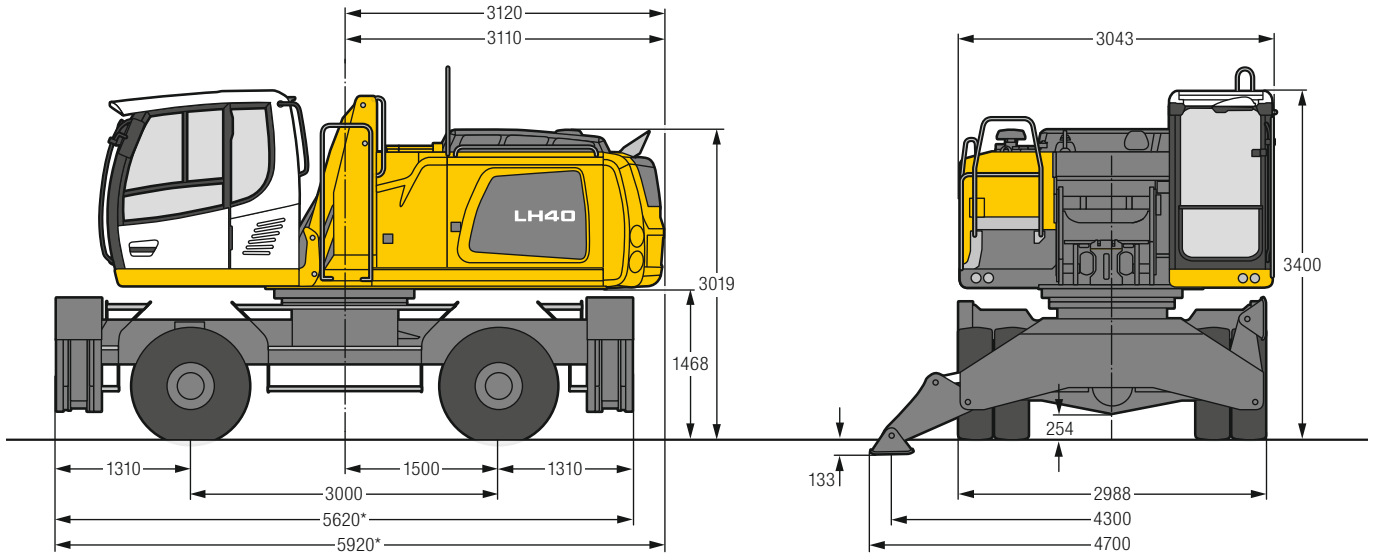

* For electric machines, the length of the machine is increased accordingly by the trailing cable / cable reel system. Detailed dimensions are available on request.

LH 40 M – Choice of cab elevation

Cab elevation LFC (rigid elevation)

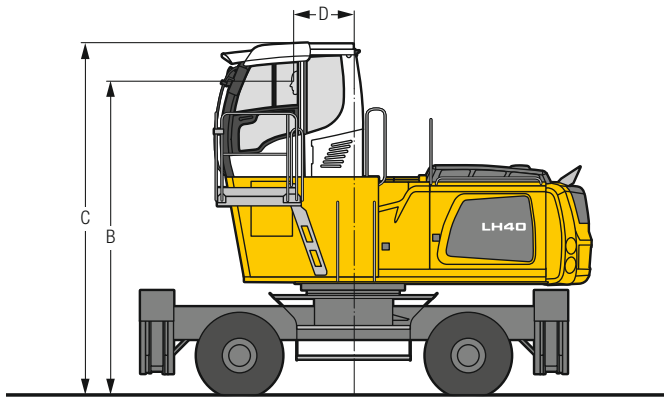

Increase type	LFC 120
Height	1,200 mm
B	4,138 mm
C	4,641 mm
D	788 mm

A rigid cab elevation has a fixed eye level height. For a lower transport height, the shell of the cab can be removed and replaced by a transport device. The dimension C is in this machine design for all rigid cab elevations 3,745 mm.

Cab elevation LHC (hydraulic elevation)

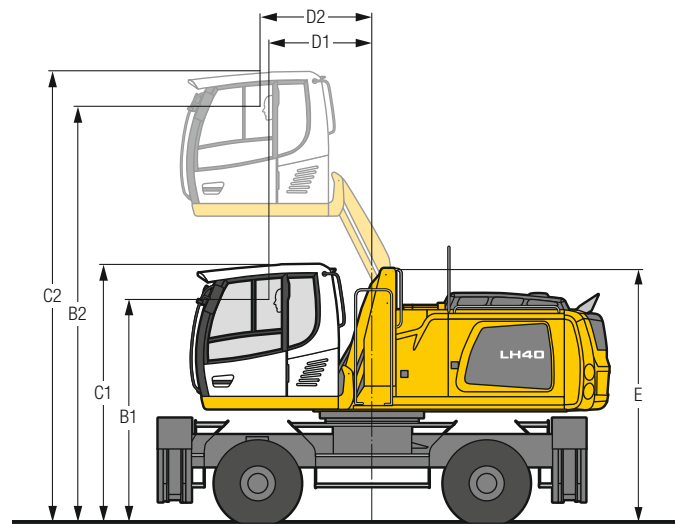

Increase type	LHC 255
B1	2,938 mm
B2	5,485 mm
C1	3,400 mm
C2	5,947 mm
D1	1,343 mm
D2	1,468 mm
E	3,343 mm

The hydraulically adjustable cab allows the driver, that he can choose his field of view freely and at any time within the stroke.

Tyres 12.00-20

LH 50 M – Dimensions

Industry

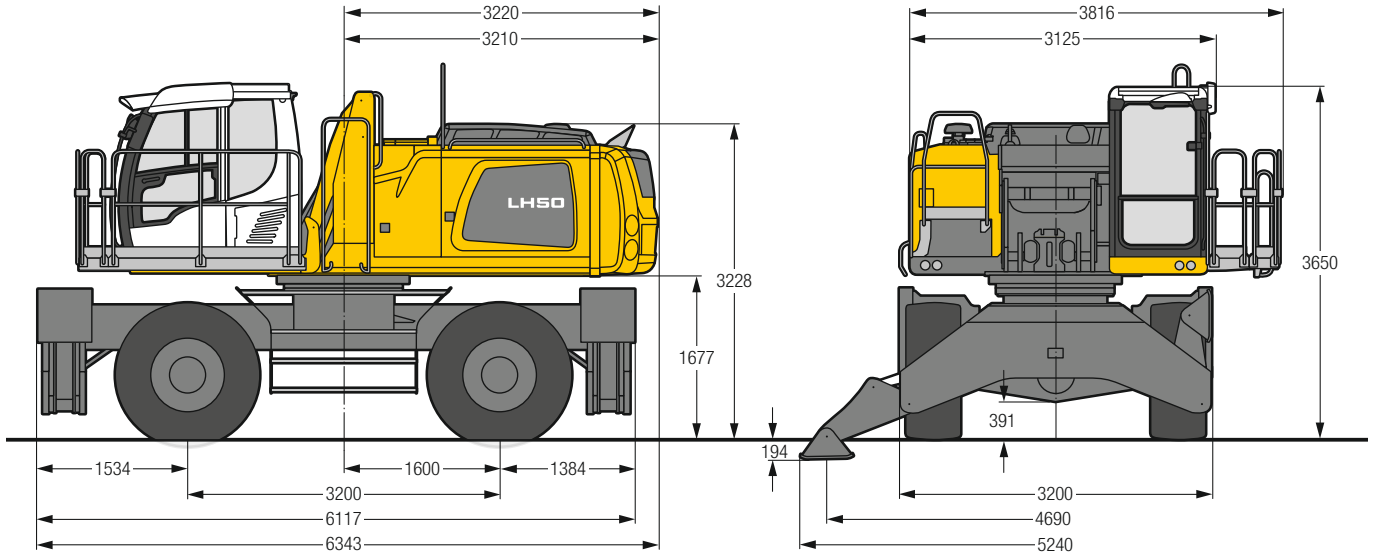

LH 50 M – Choice of cab elevation

Cab elevation LFC (rigid elevation)

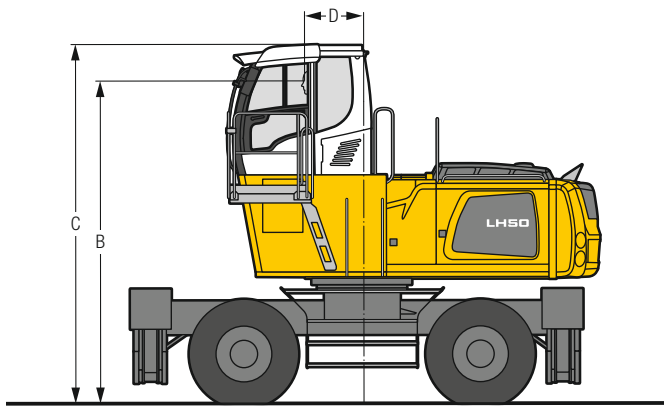

Increase type	LFC 120
Height	1,200 mm
B	4,347 mm
C	4,850 mm
D	788 mm

A rigid cab elevation has a fixed eye level height. For a lower transport height, the shell of the cab can be removed and replaced by a transport device. The dimension C is in this machine design for all rigid cab elevations 3,954 mm.

Cab elevation LHC (hydraulic elevation)

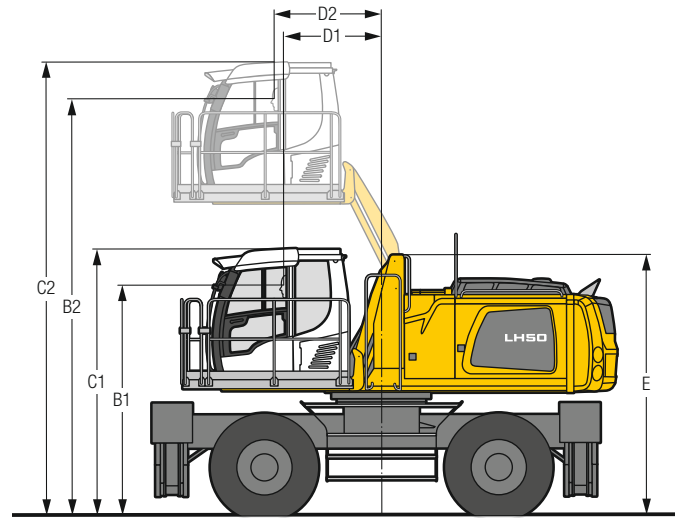

Increase type	LHC 255	LHC 340-35
B1	3,147 mm	3,495 mm
B2	5,694 mm	6,913 mm
C1	3,650 mm	3,998 mm
C2	6,197 mm	7,417 mm
D1	1,343 mm	2,454 mm
D2	1,468 mm	2,456 mm
E	3,552 mm	3,942 mm

The hydraulically adjustable cab allows the driver, that he can choose his field of view freely and at any time within the stroke.

Tyres 16.00-25

LH 40 C – Dimensions

Industry

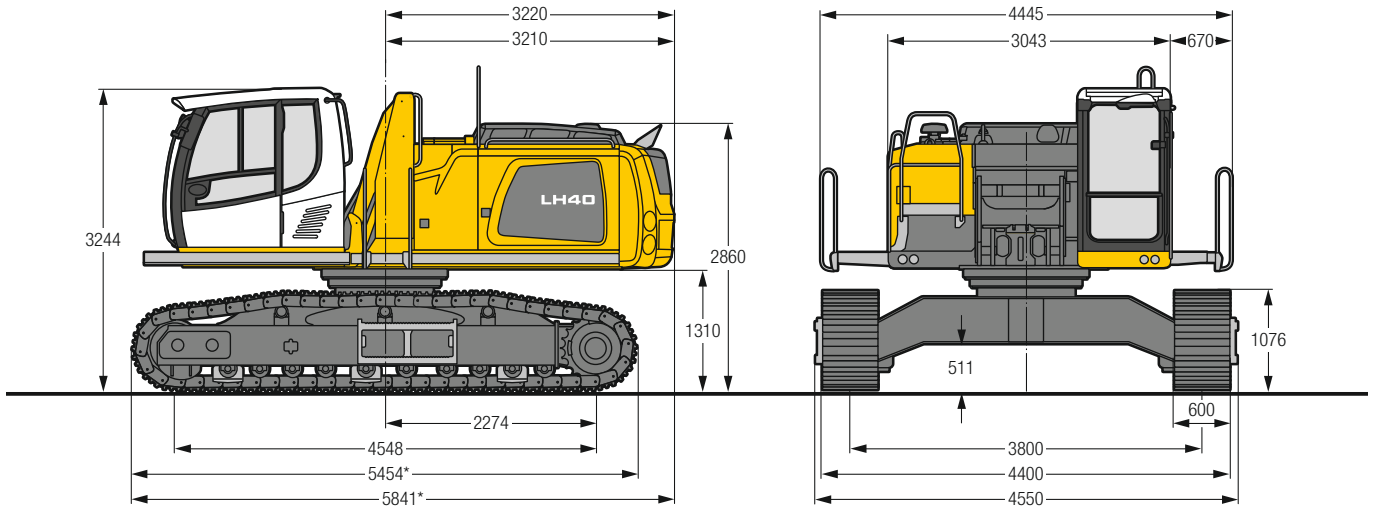

* For electric machines, the length of the machine is increased accordingly by the trailing cable / cable reel system. Detailed dimensions are available on request.

LH 40 C – Choice of cab elevation

Cab elevation LFC (rigid elevation)

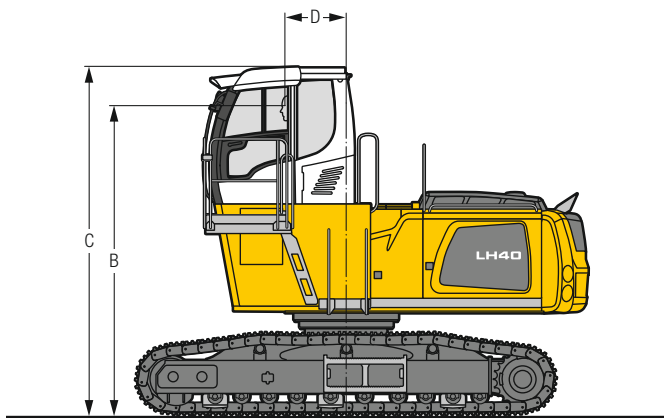

Increase type	LFC 120
Height	1,200 mm
B	3,980 mm
C	4,483 mm
D	788 mm

A rigid cab elevation has a fixed eye level height. For a lower transport height, the shell of the cab can be removed and replaced by a transport device. The dimension C is in this machine design for all rigid cab elevations 3,587 mm.

Cab elevation LHC (hydraulic elevation)

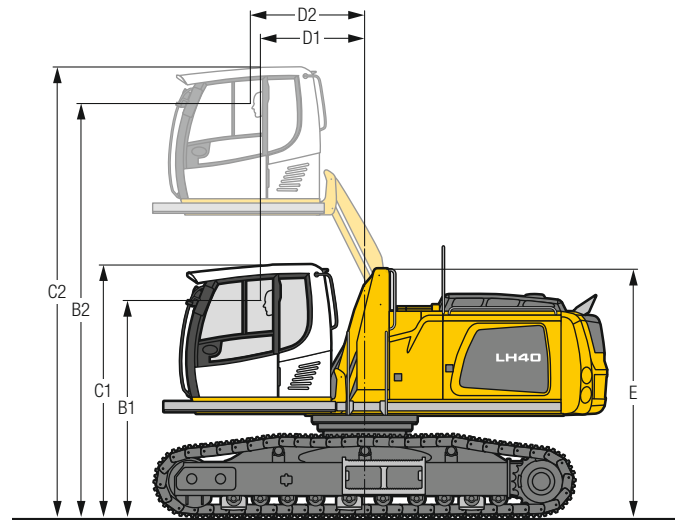

Increase type	LHC 255
B1	2,779 mm
B2	5,326 mm
C1	3,244 mm
C2	5,791 mm
D1	1,343 mm
D2	1,468 mm
E	3,185 mm

The hydraulically adjustable cab allows the driver, that he can choose his field of view freely and at any time within the stroke.

LH 50 M HR – Dimensions

Industry

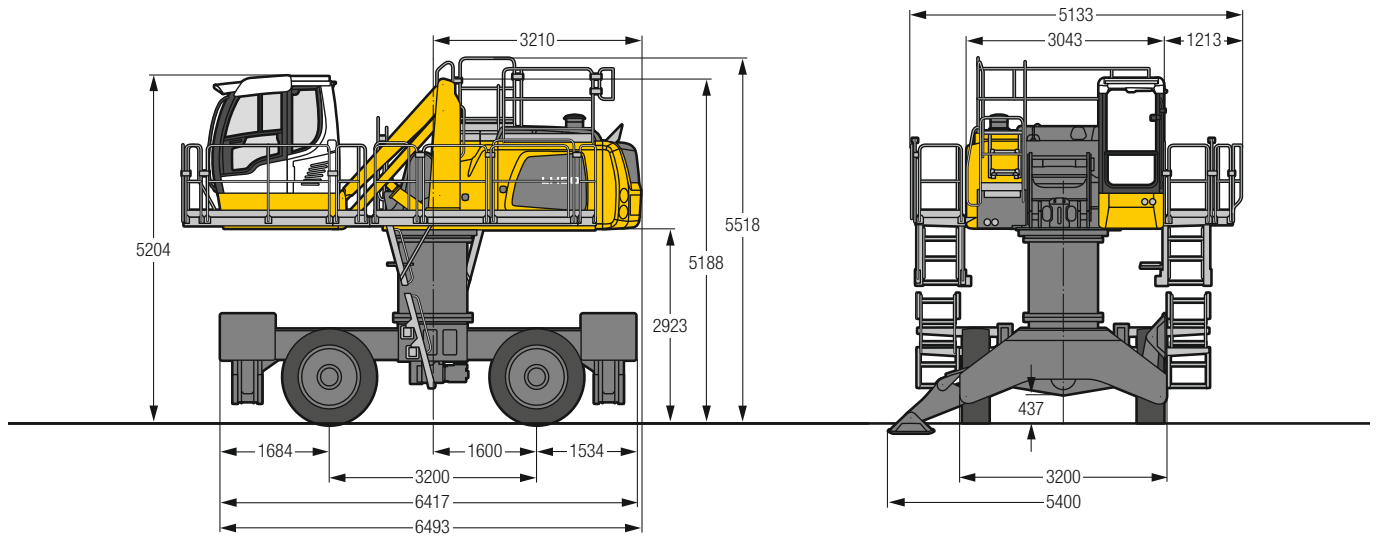

LH 50 M HR – Cab elevation

Cab elevation LHC
(hydraulic elevation)

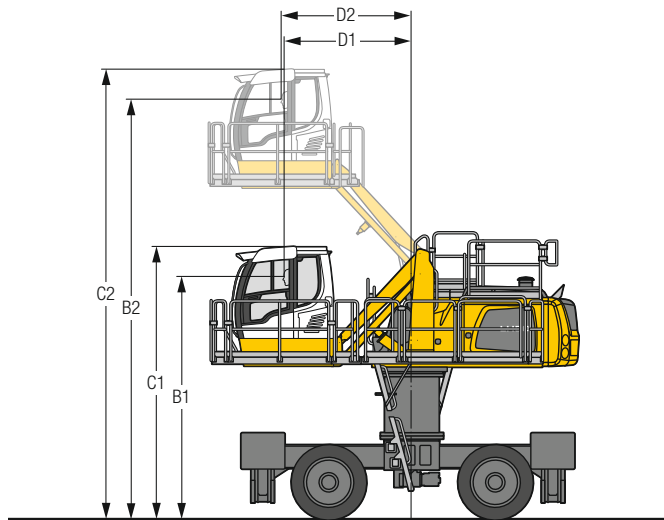

Increase type	LHC 340-35
B1	4,663 mm
B2	8,080 mm
C1	5,204 mm
C2	8,621 mm
D1	2,442 mm
D2	2,484 mm

The hydraulically adjustable cab allows the driver, that he can choose his field of view freely and at any time within the stroke.

Tyres 16.00-25

LH 50 C HR – Dimensions

Industry

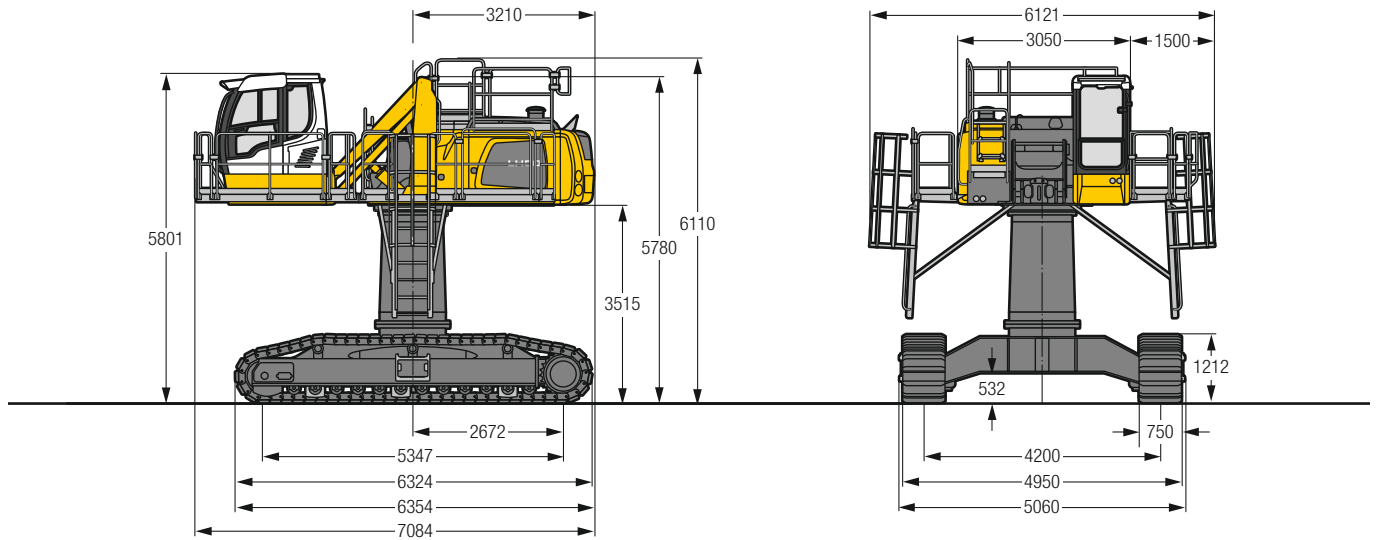

LH 50 C HR – Cab elevation

Cab elevation LHC
(hydraulic elevation)

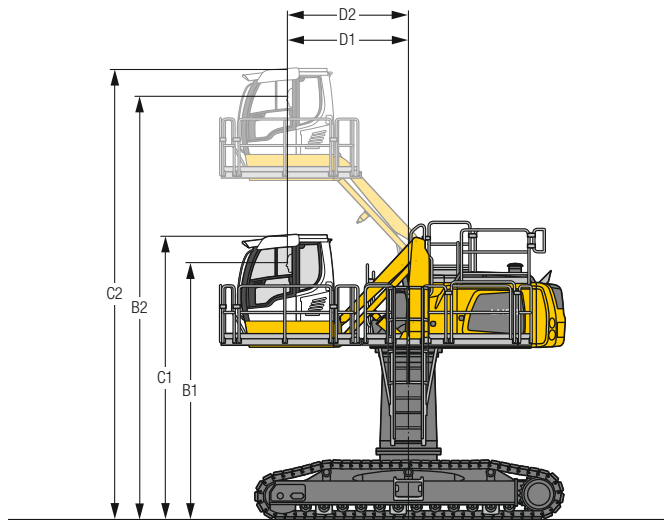

Increase type	LHC 340-35
B1	5,258 mm
B2	8,673 mm
C1	5,801 mm
C2	9,216 mm
D1	2,484 mm
D2	2,485 mm

The hydraulically adjustable cab allows the driver, that he can choose his field of view freely and at any time within the stroke.

Kinematic variant 2A

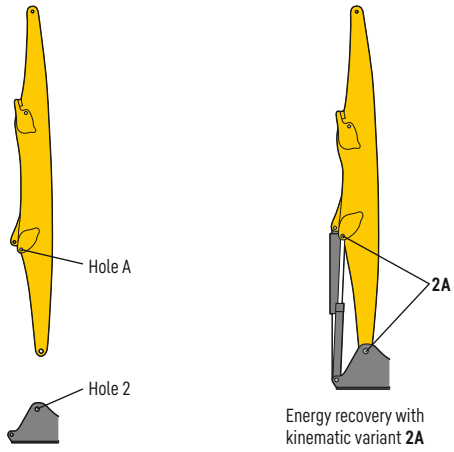

Kinematic variant 2D / 2C

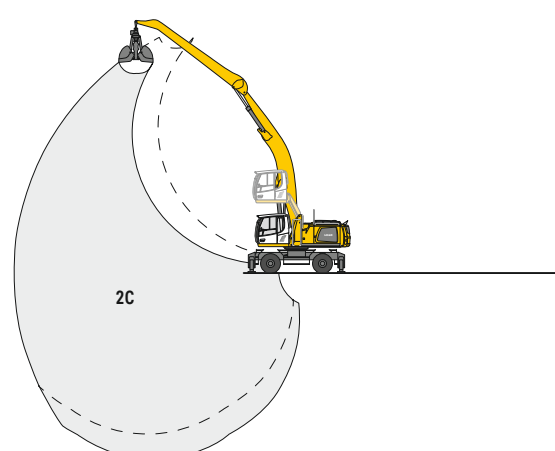
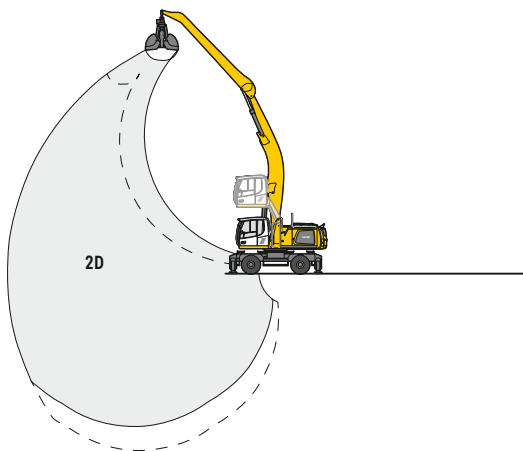
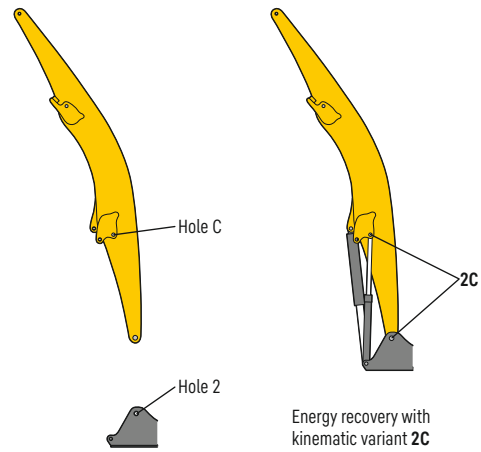
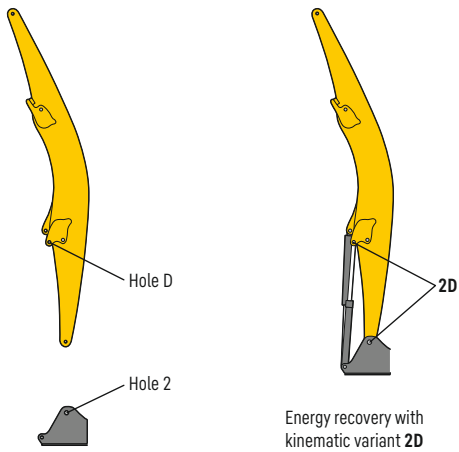

Altered range curve with additional reach depth, e.g. for unloading from ships

LH 40 M – Equipment GA13

Industry – Kinematic 2A

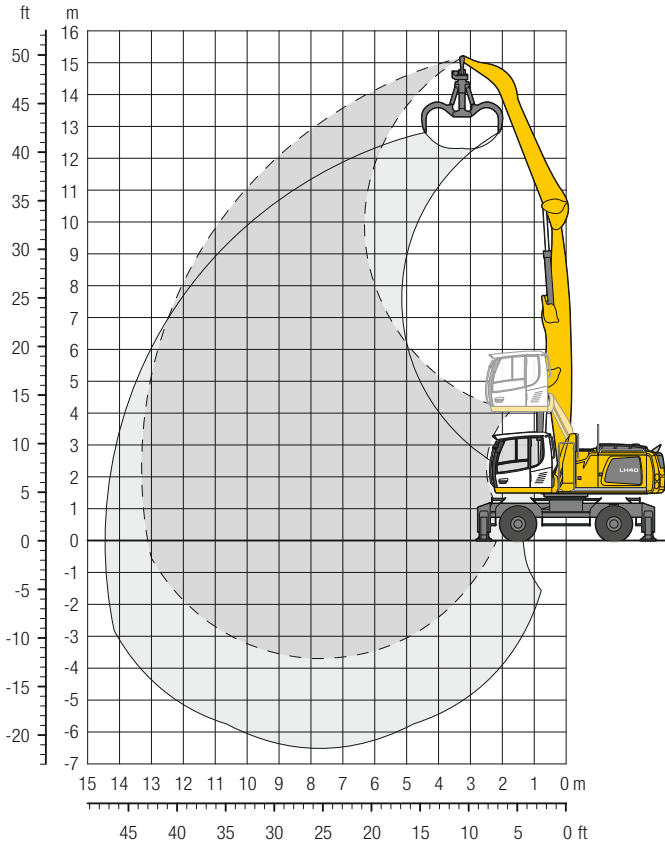

Dimensions

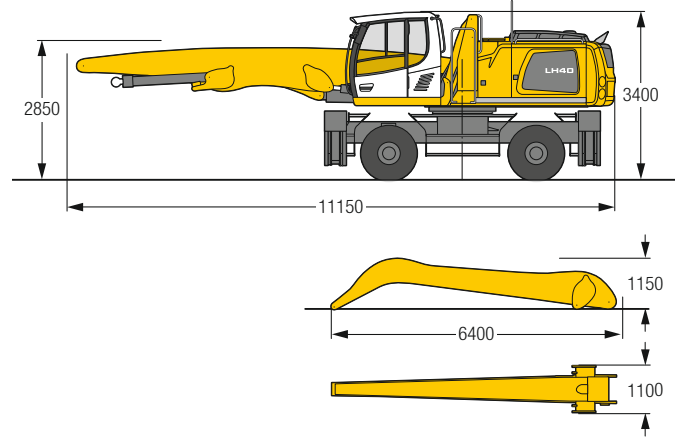

Operating weight

The operating weight includes the basic machine with 4 point outriggers, hydr. cab elevation, 8 solid tyres plus intermediate rings, straight boom 7.60 m, angled stick 6.00 m and multi-tine grab GMM 50-5/0.90 m³ semi-closed tines.

Weight 38,200 kg

m	Undercarriage	4.5m		6.0m		7.5m		9.0m		10.5m		12.0m		13.5m		15.0m		16.5m		18.0m		Max. reach		m
		Can be slewed through 360°	In longitudinal position of undercarriage	Can be slewed through 360°	In longitudinal position of undercarriage	Can be slewed through 360°	In longitudinal position of undercarriage	Can be slewed through 360°	In longitudinal position of undercarriage	Can be slewed through 360°	In longitudinal position of undercarriage	Can be slewed through 360°	In longitudinal position of undercarriage	Can be slewed through 360°	In longitudinal position of undercarriage	Can be slewed through 360°	In longitudinal position of undercarriage	Can be slewed through 360°	In longitudinal position of undercarriage	Can be slewed through 360°	In longitudinal position of undercarriage	Can be slewed through 360°	In longitudinal position of undercarriage	
15.0	Stabilizers raised 4 pt. outriggers down																					9.7*	9.7*	3.7
13.5	Stabilizers raised 4 pt. outriggers down			8.8*	8.8*																	6.7*	6.7*	7.1
12.0	Stabilizers raised 4 pt. outriggers down			9.6	9.8*	6.6	8.4	4.7	6.0*													4.6	5.8*	9.1
10.5	Stabilizers raised 4 pt. outriggers down			9.8*	9.8*	6.7	8.4*	4.9	6.3													5.8*	5.8*	10.5
9.0	Stabilizers raised 4 pt. outriggers down					6.7	8.4*	4.9	6.3	3.7	4.8											3.6	4.7	11.5
7.5	Stabilizers raised 4 pt. outriggers down			9.4	9.8*	8.3*	8.3*	7.5*	7.5*	6.8*	6.8*											5.3*	5.3*	11.5
6.0	Stabilizers raised 4 pt. outriggers down			6.6	8.4	6.6	8.4	4.8	6.2	3.7	4.7	2.8	3.7									3.0	4.0	12.3
4.5	Stabilizers raised 4 pt. outriggers down			9.8*	9.8*	8.5*	8.5*	7.6*	7.6*	6.8*	6.8*	5.8*	5.8*									5.0*	5.0*	12.3
3.0	Stabilizers raised 4 pt. outriggers down			9.0	10.4*	6.3	8.1	4.7	6.0	3.6	4.6	2.8	3.7									2.7	3.5	12.8
1.5	Stabilizers raised 4 pt. outriggers down			10.4*	10.4*	8.9*	8.9*	7.8*	7.8*	6.9*	6.9*	5.8	6.2*									4.9*	4.9*	12.8
0	Stabilizers raised 4 pt. outriggers down	13.0	14.3*	8.3	10.9	5.9	7.7	4.4	5.8	3.4	4.5	2.7	3.6								2.4	3.2	13.1	
-1.5	Stabilizers raised 4 pt. outriggers down	14.3*	14.3*	11.2*	11.2*	9.3*	9.3*	8.0*	8.0*	7.0*	7.0*	5.7	6.2*								4.8*	4.8*	13.1	
-3.0	Stabilizers raised 4 pt. outriggers down	11.4	15.5	7.5	10.0	5.5	7.2	4.2	5.5	3.3	4.3	2.6	3.5								2.3	3.1	13.3	
	Stabilizers raised 4 pt. outriggers down	16.1*	16.1*	12.1*	12.1*	9.8*	9.8*	8.2*	8.2*	6.9	7.1*	5.6	6.1*								2.2	2.9	13.3	
	Stabilizers raised 4 pt. outriggers down	10.0	13.9	6.8	9.2	5.0	6.7	3.9	5.2	3.1	4.2	2.5	3.4								4.8	4.9*	13.3	
	Stabilizers raised 4 pt. outriggers down	16.9*	16.9*	12.8*	12.8*	10.1*	10.1*	8.4*	8.4*	6.7	7.1*	5.5	6.0*								2.1	2.9	13.1	
	Stabilizers raised 4 pt. outriggers down	9.1	9.5*	6.3	8.6	4.7	6.4	3.7	5.0	3.0	4.0	2.4	3.3								4.8	4.8*	13.1	
	Stabilizers raised 4 pt. outriggers down	9.5*	9.5*	12.8*	12.8*	10.1*	10.1*	8.2	8.3*	6.6	6.9*	5.4	5.6*								2.1	2.9	13.1	
	Stabilizers raised 4 pt. outriggers down	8.7	9.0*	6.0	8.3	4.5	6.1	3.5	4.8	2.9	3.9	2.4	3.3								4.3*	4.3*	12.4	
	Stabilizers raised 4 pt. outriggers down	9.0*	9.0*	12.0*	12.0*	9.6*	9.6*	7.8*	7.8*	6.3*	6.3*	4.8*	4.8*								2.3	3.2	12.4	
	Stabilizers raised 4 pt. outriggers down	5.8	8.2	4.4	6.0	3.5	4.7	2.8	3.9	2.8	3.9	2.8	3.9								4.4*	4.4*	10.5	
	Stabilizers raised 4 pt. outriggers down	10.3*	10.3*	8.4*	8.4*	6.8*	6.8*	5.3*	5.3*	4.8*	4.8*	3.9	4.8*								2.8	3.9	10.5	

Height Can be slewed through 360° In longitudinal position of undercarriage Max. reach * Limited by hydr. capacity

The lift capacities on the stick end without attachment are stated in metric tons (t) and are valid on a firm, level supporting surface with blocked oscillating axle. These capacities can be slewed through 360° with the undercarriage in the transverse position. Capacities in the longitudinal position of the undercarriage (+15°) are specified over the steering axle with the stabilizers raised and over the rigid axle with the stabilizers down. Indicated loads based on the ISO 10567 standard and do not exceed 75% of tipping or 87% of hydraulic capacity. The lift capacity values indicated are attained at the corresponding operating temperature. This operating temperature is ensured by continuous movement of the boom. Weights of fitted attachments (grabs, load hooks, etc.) and load accommodation attachment are to be deducted from the lift capacity values. The lift capacity of the unit is limited by its stability, the lifting capability of the hydraulic elements, or the maximum permissible lifting capacity of the load hook.

In accordance with the harmonised European Standard EN 474-5, hydraulic excavators used for lifting operations must be equipped with pipe fracture safety valves, an overload warning device, a load hook and a lift capacity chart.

LH 40 M – Equipment GA14

Industry – Kinematic 2A

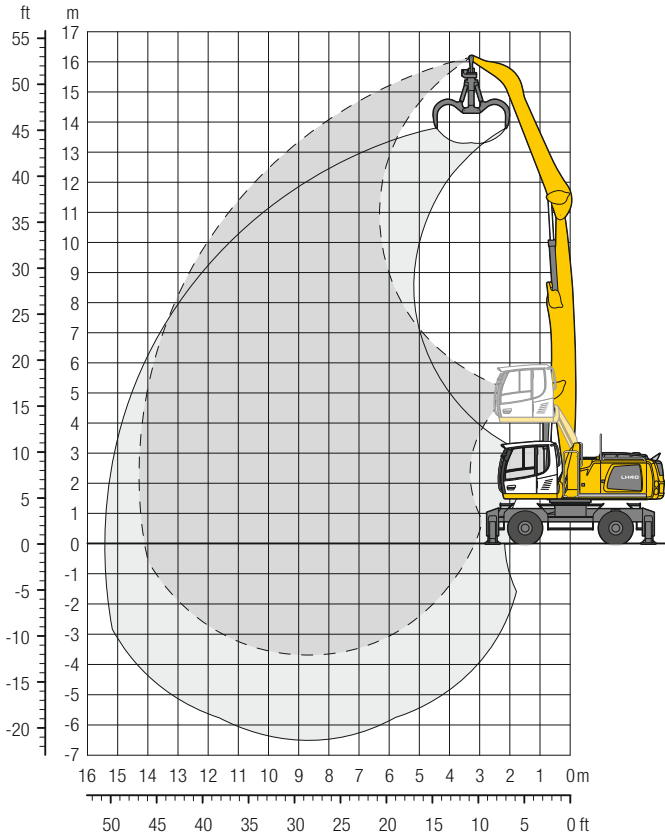

Dimensions

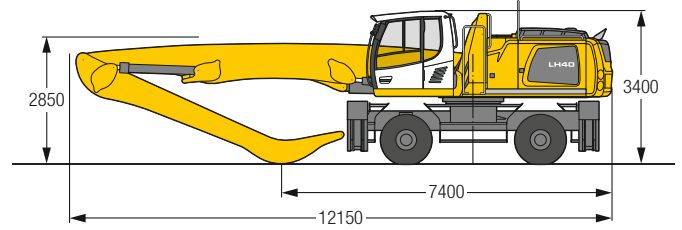

Operating weight

The operating weight includes the basic machine with 4 point outriggers, hydr. cab elevation, 8 solid tyres plus intermediate rings, straight boom 8.60 m, angled stick 6.00 m and multi-tine grab GMM 50-5/0.90 m³ semi-closed tines.

Weight 38,500 kg

m	Undercarriage	4.5m		6.0m		7.5m		9.0m		10.5m		12.0m		13.5m		15.0m		16.5m		18.0m		m		
		Stabilizers raised	4 pt. outriggers down	Stabilizers raised	4 pt. outriggers down	Stabilizers raised	4 pt. outriggers down	Stabilizers raised	4 pt. outriggers down	Stabilizers raised	4 pt. outriggers down	Stabilizers raised	4 pt. outriggers down	Stabilizers raised	4 pt. outriggers down	Stabilizers raised	4 pt. outriggers down	Stabilizers raised	4 pt. outriggers down	Stabilizers raised	4 pt. outriggers down	Stabilizers raised	4 pt. outriggers down	Max. reach
15.0	Stabilizers raised			8.2*	8.2*																	7.3*	7.3*	6.4
15.0	4 pt. outriggers down			8.2*	8.2*																	7.3*	7.3*	6.4
13.5	Stabilizers raised			9.5	9.8*	6.5	8.3															4.8	6.1*	8.8
13.5	4 pt. outriggers down			9.8*	9.8*	8.4*	8.4*															6.1*	6.1*	8.8
12.0	Stabilizers raised					6.7	8.2*	4.8	6.2													3.5	4.6	10.5
12.0	4 pt. outriggers down					8.2*	8.2*	7.3*	7.3*													5.5*	5.5*	10.5
10.5	Stabilizers raised					6.7	8.1*	4.9	6.3	3.6	4.7											2.9	3.8	11.7
10.5	4 pt. outriggers down					8.1*	8.1*	7.2*	7.2*	6.5*	6.5*											5.1*	5.1*	11.7
9.0	Stabilizers raised					6.6	8.2*	4.8	6.2	3.6	4.7	2.7	3.7									2.4	3.3	12.6
9.0	4 pt. outriggers down					8.2*	8.2*	7.2*	7.2*	6.5*	6.5*	5.8	5.8*									4.9*	4.9*	12.6
7.5	Stabilizers raised			9.2	10.0*	6.4	8.2	4.7	6.0	3.5	4.6	2.7	3.6									2.1	2.9	13.3
7.5	4 pt. outriggers down			10.0*	10.0*	8.5*	8.5*	7.4*	7.4*	6.5*	6.5*	5.8	5.8*									4.8	4.8*	13.3
6.0	Stabilizers raised	12.8*	12.8*	8.5	10.6*	6.0	7.8	4.4	5.8	3.4	4.5	2.6	3.5	2.1	2.8							1.9	2.7	13.8
6.0	4 pt. outriggers down	12.8*	12.8*	10.6*	10.6*	8.8*	8.8*	7.6*	7.6*	6.6*	6.6*	5.7	5.9*	4.6	5.2*							4.5	4.8*	13.8
4.5	Stabilizers raised	11.8	15.0*	7.7	10.2	5.5	7.3	4.1	5.5	3.2	4.3	2.5	3.4	2.0	2.8							1.8	2.5	14.1
4.5	4 pt. outriggers down	15.0*	15.0*	11.4*	11.4*	9.2*	9.2*	7.8*	7.8*	6.7*	6.7*	5.6	5.9*	4.6	5.1*							4.2	4.7*	14.1
3.0	Stabilizers raised	9.9	13.9	6.8	9.2	5.0	6.7	3.8	5.1	3.0	4.1	2.4	3.3	1.9	2.7							1.7	2.5	14.3
3.0	4 pt. outriggers down	15.0*	15.0*	12.0*	12.0*	9.6*	9.6*	8.0*	8.0*	6.6	6.8*	5.4	5.9*	4.5	5.0*							4.1	4.4*	14.3
1.5	Stabilizers raised	5.5*	5.5*	6.0	8.4	4.5	6.2	3.5	4.8	2.8	3.9	2.3	3.2	1.9	2.6							1.7	2.4	14.3
1.5	4 pt. outriggers down	5.5*	5.5*	12.3*	12.3*	9.7*	9.7*	8.0*	8.0*	6.4	6.8*	5.3	5.8*	4.4	4.8*							4.1	4.1*	14.3
0	Stabilizers raised	5.0*	5.0*	5.5	7.9	4.2	5.9	3.3	4.6	2.7	3.7	2.2	3.1	1.8	2.6							1.7	2.4	14.1
0	4 pt. outriggers down	5.0*	5.0*	12.0*	12.0*	9.6*	9.6*	7.8	7.8*	6.2	6.6*	5.2	5.5*	4.4*	4.4*							3.7*	3.7*	14.1
-1.5	Stabilizers raised	5.8*	5.8*	5.3	7.6	4.0	5.6	3.1	4.4	2.6	3.6	2.1	3.0									1.8	2.6	13.4
-1.5	4 pt. outriggers down	5.8*	5.8*	10.9*	10.9*	8.9*	8.9*	7.3*	7.3*	6.1*	6.1*	4.9*	4.9*									3.7*	3.7*	13.4
-3.0	Stabilizers raised			5.2	7.5	3.9	5.5	3.1	4.4	2.5	3.6											2.2	3.2	11.5
-3.0	4 pt. outriggers down			9.0*	9.0*	7.7*	7.7*	6.4*	6.4*	5.2*	5.2*											4.4*	4.4*	11.5

Height Can be slewed through 360° In longitudinal position of undercarriage Max. reach * Limited by hydr. capacity

The lift capacities on the stick end without attachment are stated in metric tons (t) and are valid on a firm, level supporting surface with blocked oscillating axle. These capacities can be slewed through 360° with the undercarriage in the transverse position. Capacities in the longitudinal position of the undercarriage (±15°) are specified over the steering axle with the stabilizers raised and over the rigid axle with the stabilizers down. Indicated loads based on the ISO 10567 standard and do not exceed 75% of tipping or 87% of hydraulic capacity. The lift capacity values indicated are attained at the corresponding operating temperature. This operating temperature is ensured by continuous movement of the boom. Weights of fitted attachments (grabs, load hooks, etc.) and load accommodation attachment are to be deducted from the lift capacity values. The lift capacity of the unit is limited by its stability, the lifting capability of the hydraulic elements, or the maximum permissible lifting capacity of the load hook.

In accordance with the harmonised European Standard EN 474-5, hydraulic excavators used for lifting operations must be equipped with pipe fracture safety valves, an overload warning device, a load hook and a lift capacity chart.

LH 40 M – Equipment GA16

Industry – Kinematic 2A

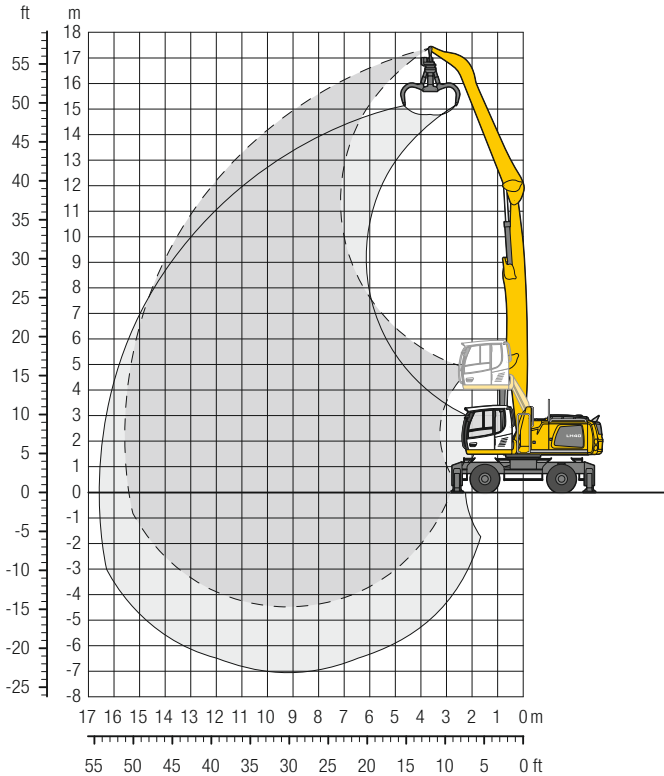

Dimensions

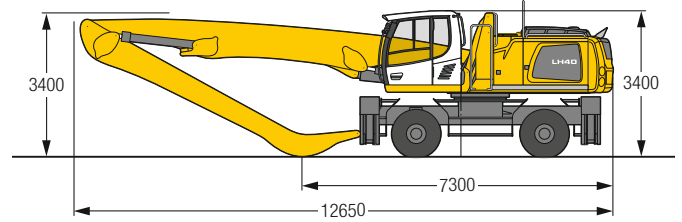

Operating weight

The operating weight includes the basic machine with 4 point outriggers, hydr. cab elevation, 8 solid tyres plus intermediate rings, straight boom 9.10 m, angled stick 6.80 m and multi-tine grab GM 65 / 0.60 m³ semi-closed tines.

Weight	38,500 kg
--------	-----------

m	Undercarriage	4.5 m		6.0 m		7.5 m		9.0 m		10.5 m		12.0 m		13.5 m		15.0 m		16.5 m		18.0 m		Max. reach		m
		Stabilizers raised	4 pt. outriggers down	Stabilizers raised	4 pt. outriggers down	Stabilizers raised	4 pt. outriggers down	Stabilizers raised	4 pt. outriggers down	Stabilizers raised	4 pt. outriggers down	Stabilizers raised	4 pt. outriggers down	Stabilizers raised	4 pt. outriggers down	Stabilizers raised	4 pt. outriggers down	Stabilizers raised	4 pt. outriggers down	Stabilizers raised	4 pt. outriggers down	Stabilizers raised	4 pt. outriggers down	
16.5				7.4*	7.4*																	7.0*	7.0*	6.2
15.0				7.4*	7.4*																	4.7	5.6*	8.9
13.5						6.6	7.6*															5.6*	5.6*	10.8
12.0						7.0	7.9*	5.0	6.4	3.6	4.7											3.4	4.4	12.2
10.5						7.9*	7.9*	6.9*	6.9*	5.5*	5.5*											4.9*	4.9*	13.2
9.0						7.1	7.7*	5.1	6.5	3.8	4.9	2.8	3.7									2.7	3.6	14.0
7.5						7.7*	7.7*	6.8*	6.8*	6.1*	6.1*	5.0*	5.0*									4.6*	4.6*	14.7
6.0						7.0	7.7*	5.1	6.5	3.8	4.9	2.8	3.8									2.2	3.0	15.1
4.5						7.7*	7.7*	6.8*	6.8*	6.1*	6.1*	5.5*	5.5*									4.3*	4.3*	15.4
3.0						6.9	7.9*	5.0	6.4	3.7	4.8	2.8	3.8	2.1	2.9							1.9	2.6	15.6
1.5						9.9*	9.9*	6.6	8.1*	4.8	6.2	3.6	4.7	4.7	5.0*							4.2*	4.2*	15.6
0						9.6*	9.6*	8.1*	8.1*	7.0*	7.0*	6.2*	6.2*	5.5*	5.5*							2.1	2.9	15.4
-1.5						9.9*	9.9*	6.1	7.9	4.5	5.9	3.4	4.5	2.6	3.5	2.0	2.8	1.6	2.2			4.0	4.1*	13.5
-3.0						10.2*	10.2*	8.4*	8.4*	7.2*	7.2*	6.3*	6.3*	5.6*	5.6*	4.6	5.0*	3.8	4.3*			1.5	2.2	
-4.5						12.1	14.4*	7.8	10.3	5.5	7.3	4.1	5.5	3.2	4.3	2.5	3.4	1.9	2.7			1.5	2.2	
						14.4*	14.4*	10.9*	10.9*	8.8*	8.8*	7.4*	7.4*	6.4*	6.4*	5.5	5.6*	4.5	5.0*			3.8	4.3*	
						10.0	14.0	6.8	9.2	4.9	6.7	3.7	5.1	2.9	4.0	2.3	3.2	1.8	2.6			1.5	2.1	
						15.7*	15.7*	11.6*	11.6*	9.2*	9.2*	7.6*	7.6*	6.5*	6.5*	5.3	5.6*	4.4	4.9*			3.7	4.2*	
						5.0*	5.0*	5.8	8.2	4.4	6.1	3.4	4.7	2.7	3.7	2.1	3.0	1.7	2.5			1.4	2.1	
						5.0*	5.0*	11.9*	11.9*	9.4*	9.4*	7.7*	7.7*	6.3	6.5*	5.2	5.6*	4.3	4.8*			3.7	4.0*	
						4.2*	4.2*	5.2	7.5	3.9	5.6	3.1	4.4	2.5	3.5	2.0	2.9	1.6	2.4			1.4	2.0	
						4.2*	4.2*	11.5*	11.5*	9.3*	9.3*	7.6	7.6*	6.1	6.4*	5.0	5.4*	4.2	4.6*			3.6*	3.6*	
						4.7*	4.7*	4.8	7.1	3.6	5.3	2.9	4.2	2.3	3.4	1.9	2.8	1.6	2.4			1.4	2.1	
						4.7*	4.7*	9.7*	9.7*	8.8*	8.8*	7.2*	7.2*	5.9	6.1*	4.9	5.1*	4.1*	4.1*			3.1*	3.1*	
						4.7	7.0	3.5	5.1	2.7	4.0	2.2	3.3	1.8	2.7							1.6	2.3	
						9.3*	9.3*	7.8*	7.8*	6.5*	6.5*	5.4*	5.4*	4.5*	4.5*							3.4*	3.4*	

Height Can be slewed through 360° In longitudinal position of undercarriage Max. reach * Limited by hydr. capacity

The lift capacities on the stick end without attachment are stated in metric tons (t) and are valid on a firm, level supporting surface with blocked oscillating axle. These capacities can be slewed through 360° with the undercarriage in the transverse position. Capacities in the longitudinal position of the undercarriage (±15°) are specified over the steering axle with the stabilizers raised and over the rigid axle with the stabilizers down. Indicated loads based on the ISO 10567 standard and do not exceed 75% of tipping or 87% of hydraulic capacity. The lift capacity values indicated are attained at the corresponding operating temperature. This operating temperature is ensured by continuous movement of the boom. Weights of fitted attachments (grabs, load hooks, etc.) and load accommodation attachment are to be deducted from the lift capacity values. The lift capacity of the unit is limited by its stability, the lifting capability of the hydraulic elements, or the maximum permissible lifting capacity of the load hook.

In accordance with the harmonised European Standard EN 474-5, hydraulic excavators used for lifting operations must be equipped with pipe fracture safety valves, an overload warning device, a load hook and a lift capacity chart.

LH 40 M – Equipment AF15

Industry – Kinematic 2D

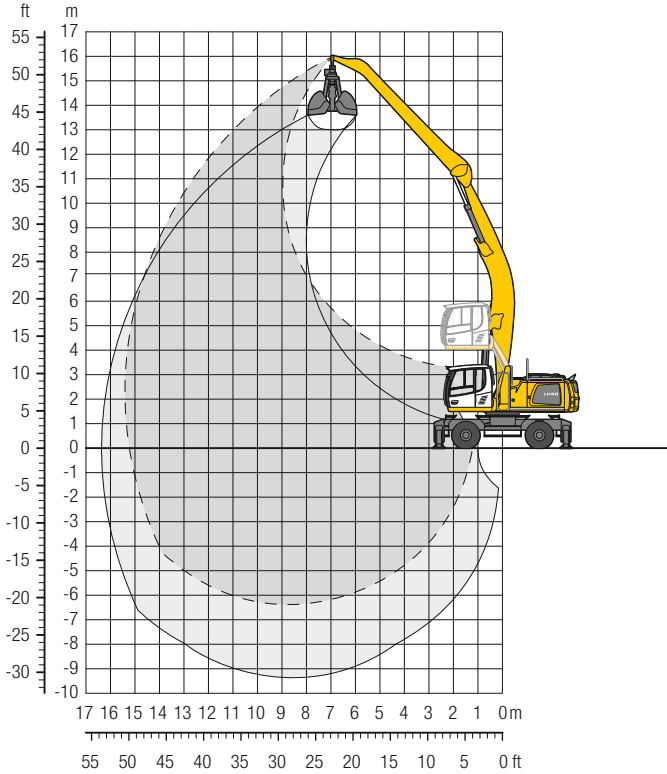

Dimensions

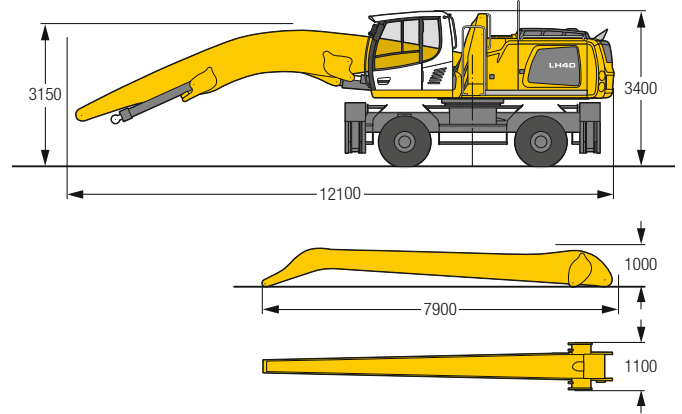

Operating weight

The operating weight includes the basic machine with 4 point outriggers, hydr. cab elevation, 8 solid tyres plus intermediate rings, angled boom 8.60m, flat angled stick 7.50m and grab for loose material GMZ 40 /1.50m³.

Weight 39,100 kg

m	Undercarriage	4.5m		6.0m		7.5m		9.0m		10.5m		12.0m		13.5m		15.0m		16.5m		18.0m		m		
15.0	Stabilizers raised																					4.7*	4.7*	8.6
	4 pt. outriggers down							5.4	5.9*													4.7*	4.7*	
13.5	Stabilizers raised							5.9*	5.9*													4.2*	4.2*	10.5
	4 pt. outriggers down							5.5	5.7*	4.1	5.2											3.1	4.0*	
12.0	Stabilizers raised							5.7*	5.7*	5.3*	5.3*											4.9*	4.9*	11.9
	4 pt. outriggers down							5.5	5.7*	4.1	5.2*	3.1	4.0									2.5	3.4	
10.5	Stabilizers raised							5.8*	5.8*	5.3*	5.3*	4.9*	4.9*									3.8*	3.8*	13.0
	4 pt. outriggers down							5.5	5.8*	4.1	5.2	3.1	4.0	2.3	3.1							2.2	2.9	
9.0	Stabilizers raised							5.8*	5.8*	5.3*	5.3*	4.9*	4.9*	4.3*	4.3*							3.7*	3.7*	13.8
	4 pt. outriggers down							5.3	5.9*	4.0	5.1	3.0	3.9	2.3	3.1							1.9	2.6	
7.5	Stabilizers raised							5.9*	5.9*	5.4*	5.4*	4.9*	4.9*	4.5*	4.5*							3.7*	3.7*	14.5
	4 pt. outriggers down							5.0	6.2*	3.8	4.9	2.9	3.8	2.2	3.0							1.7	2.4	
6.0	Stabilizers raised							7.0*	7.0*	6.2*	6.2*	5.5*	5.5*	5.0*	5.0*	4.6*	4.6*					3.7*	3.7*	14.9
	4 pt. outriggers down							6.3	7.5*	4.6	6.0	3.5	4.6	2.7	3.6	2.1	2.9	1.6	2.3			1.6	2.2	
4.5	Stabilizers raised			9.0*	9.0*			6.5*	6.5*	5.7*	5.7*	5.1*	5.1*	4.6*	4.6*	3.9	4.2*					3.8*	3.8*	15.2
	4 pt. outriggers down			9.0*	9.0*	7.5*	7.5*	6.5*	6.5*	5.7*	5.7*	5.1*	5.1*	4.6*	4.6*	3.9	4.2*					1.5	2.1	
3.0	Stabilizers raised	12.1	13.1*	7.9	9.9*	5.6	7.4	4.2	5.6	3.2	4.3	2.5	3.4	2.0	2.8	1.6	2.2					1.5	2.1	15.3
	4 pt. outriggers down	13.1*	13.1*	9.9*	9.9*	8.0*	8.0*	6.8*	6.8*	5.9*	5.9*	5.2*	5.2*	4.6	4.7*	3.8	4.2*					3.7	3.9*	
1.5	Stabilizers raised	10.0	14.0	6.8	9.2	5.0	6.7	3.8	5.1	3.0	4.0	2.3	3.2	1.9	2.6	1.5	2.2					1.4	2.1	15.3
	4 pt. outriggers down	14.7*	14.7*	10.7*	10.7*	8.5*	8.5*	7.1*	7.1*	6.1*	6.1*	5.3*	5.3*	4.5	4.7*	3.8	4.1*					3.6	4.0*	
0	Stabilizers raised	8.4	9.0*	5.9	8.3	4.4	6.1	3.4	4.7	2.7	3.8	2.2	3.1	1.7	2.5	1.4	2.1					1.4	2.1	15.2
	4 pt. outriggers down	9.0*	9.0*	11.3*	11.3*	8.9*	8.9*	7.3*	7.3*	6.2*	6.2*	5.2	5.4*	4.3	4.7*	3.7	4.0*					3.6	3.9*	
-1.5	Stabilizers raised	7.5*	7.5*	5.2	7.6	3.9	5.6	3.1	4.4	2.5	3.5	2.0	2.9	1.6	2.4							1.4	2.1	14.9
	4 pt. outriggers down	7.5*	7.5*	11.4*	11.4*	9.0*	9.0*	7.4*	7.4*	6.1	6.2*	5.0	5.3*	4.2	4.5*							3.7	3.8*	
-3.0	Stabilizers raised	7.1	7.4*	4.9	7.2	3.7	5.3	2.9	4.2	2.3	3.4	1.9	2.8	1.6	2.4							1.4	2.2	14.4
	4 pt. outriggers down	7.4*	7.4*	11.0*	11.0*	8.8*	8.8*	7.2*	7.2*	5.9	6.0*	4.9	5.1*	4.2	4.2*							3.6*	3.6*	
-4.5	Stabilizers raised	7.0	7.9*	4.7	7.0	3.5	5.2	2.8	4.1	2.2	3.3	1.9	2.8	1.6	2.4							1.6	2.3	13.6
	4 pt. outriggers down	7.9*	7.9*	10.0*	10.0*	8.1*	8.1*	6.7*	6.7*	5.6*	5.6*	4.6*	4.6*	3.5*	3.5*							3.5*	3.5*	
-6.0	Stabilizers raised							3.5	5.2	2.7	4.0	2.2	3.3									2.1	3.1	11.0
	4 pt. outriggers down							7.0*	7.0*	5.8*	5.8*	4.7*	4.7*									4.4*	4.4*	

Height Can be slewed through 360° In longitudinal position of undercarriage Max. reach * Limited by hydr. capacity

The lift capacities on the stick end without attachment are stated in metric tons (t) and are valid on a firm, level supporting surface with blocked oscillating axle. These capacities can be slewed through 360° with the undercarriage in the transverse position. Capacities in the longitudinal position of the undercarriage (+15°) are specified over the steering axle with the stabilizers raised and over the rigid axle with the stabilizers down. Indicated loads based on the ISO 10567 standard and do not exceed 75% of tipping or 87% of hydraulic capacity. The lift capacity values indicated are attained at the corresponding operating temperature. This operating temperature is ensured by continuous movement of the boom. Weights of fitted attachments (grabs, load hooks, etc.) and load accommodation attachment are to be deducted from the lift capacity values. The lift capacity of the unit is limited by its stability, the lifting capability of the hydraulic elements, or the maximum permissible lifting capacity of the load hook.

In accordance with the harmonised European Standard EN 474-5, hydraulic excavators used for lifting operations must be equipped with pipe fracture safety valves, an overload warning device, a load hook and a lift capacity chart.

LH 40 M – Equipment GS11

Industry – Kinematic 2A

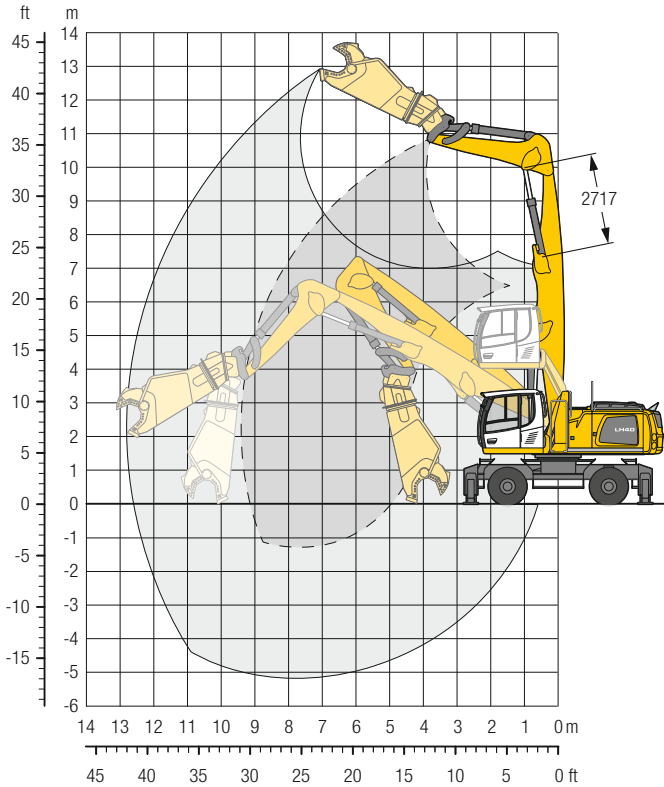

Dimensions

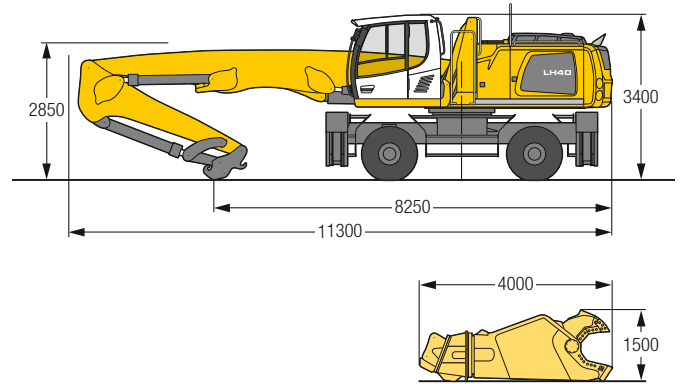

Operating weight

The operating weight includes the basic machine with 4 point outriggers, hydr. cab elevation, 8 solid tyres plus intermediate rings, straight boom 7.60 m, stick HD with tipping kinematics special 3.60 m, quick coupler SWA 66 and scrap shear Genesis GXT 445R.

Weight 43,100 kg

The stick cylinder must be limited to the measure of 2,717 mm.

m	Undercarriage	4.5 m		6.0 m		7.5 m		9.0 m		10.5 m		12.0 m		13.5 m		15.0 m		16.5 m		18.0 m		m			
		Stabilizers raised	4 pt. outriggers down	Stabilizers raised	4 pt. outriggers down	Stabilizers raised	4 pt. outriggers down	Stabilizers raised	4 pt. outriggers down	Stabilizers raised	4 pt. outriggers down	Stabilizers raised	4 pt. outriggers down	Stabilizers raised	4 pt. outriggers down	Stabilizers raised	4 pt. outriggers down	Stabilizers raised	4 pt. outriggers down	Stabilizers raised	4 pt. outriggers down	Stabilizers raised	4 pt. outriggers down	Stabilizers raised	4 pt. outriggers down
13.5	Stabilizers raised																								
12.0	4 pt. outriggers down					4.1*	4.1*															3.0	3.5*	8.3	
10.5	Stabilizers raised					4.1*	4.1*	2.1	2.9*													3.5*	3.5*		
10.5	4 pt. outriggers down							2.1	2.9*													2.5*	2.5*	9.8	
9.0	Stabilizers raised							2.9*	2.9*	0.5	1.7											0.2	1.3		
9.0	4 pt. outriggers down							2.9*	2.9*	2.1*	2.1*											1.9*	1.9*	10.9	
7.5	Stabilizers raised					4.0*	4.0*	1.9	2.9*			0.4	1.6									-	0.6		
7.5	4 pt. outriggers down					4.0*	4.0*	2.9*	2.9*	2.1*	2.1*											1.5*	1.5*	11.7	
6.0	Stabilizers raised					3.7	4.1*	1.6	3.0*	0.2	1.4			-	0.2							-	-		
6.0	4 pt. outriggers down					4.1*	4.1*	3.0*	3.0*	2.1*	2.1*	1.4*	1.4*									1.3*	1.3*	12.2	
4.5	Stabilizers raised			3.9*	3.9*	3.0	4.3*	1.1	2.6	-	1.1	-	0.0									-	-		
4.5	4 pt. outriggers down			3.9*	3.9*	4.3*	4.3*	3.1*	3.1*	2.1*	2.1*	1.3*	1.3*									1.1*	1.1*	12.6	
3.0	Stabilizers raised	2.7*	2.7*	4.7	6.5*	2.1	4.0	0.6	2.0	-	0.7	-	-									-	-		
3.0	4 pt. outriggers down	2.7*	2.7*	6.5*	6.5*	4.5*	4.5*	3.1*	3.1*	2.1*	2.1*	1.3*	1.3*									0.9*	0.9*	12.8	
1.5	Stabilizers raised	6.5	10.4*	3.1	5.6	1.2	3.0	0.0	1.4	-	0.3	-	-									-	-		
1.5	4 pt. outriggers down	10.4*	10.4*	6.8*	6.8*	4.6*	4.6*	3.1*	3.1*	2.0*	2.0*	1.1*	1.1*									0.7*	0.7*	12.8	
0	Stabilizers raised	4.0	7.5*	1.8	4.2	0.4	2.2	-	0.9	-	-	-	-									-	-		
0	4 pt. outriggers down	7.5*	7.5*	6.7*	6.7*	4.5*	4.5*	3.0*	3.0*	1.8*	1.8*	0.9*	0.9*									0.5*	0.5*	12.6	
-1.5	Stabilizers raised	2.5	4.1*	0.8	3.2	-	1.5	-	0.4	-	-	-	-									-	-		
-1.5	4 pt. outriggers down	4.1*	4.1*	6.1*	6.1*	4.0*	4.0*	2.6*	2.6*	1.4*	1.4*	0.4*	0.4*									0.3*	0.3*	12.2	
-3.0	Stabilizers raised	1.9	4.5*	0.3	2.6	-	1.1	-	0.2	-	-	-	-									-	-		
-3.0	4 pt. outriggers down	4.5*	4.5*	4.9*	4.9*	3.2*	3.2*	1.9*	1.9*	0.7*	0.7*	-	-									-	-	11.6	
-4.5	Stabilizers raised			0.1	2.4	-	0.9	-	-	-	-	-	-									-	-		
-4.5	4 pt. outriggers down			3.0*	3.0*	1.8*	1.8*	0.7*	0.7*	-	-	-	-									-	-	10.6	

Height Can be slewed through 360° In longitudinal position of undercarriage Max. reach * Limited by hydr. capacity

The lift capacities on the stick end without attachment are stated in metric tons (t) and are valid on a firm, level supporting surface with blocked oscillating axle. These capacities can be slewed through 360° with the undercarriage in the transverse position. Capacities in the longitudinal position of the undercarriage (+15°) are specified over the steering axle with the stabilizers raised and over the rigid axle with the stabilizers down. Indicated loads based on the ISO 10567 standard and do not exceed 75% of tipping or 87% of hydraulic capacity. The lift capacity values indicated are attained at the corresponding operating temperature. The values are calculated for the static state of the energy recovery cylinder. The maximum lift capacity for the quick coupler's load hook is 12t. Without attachment the lift capacity will increase by 5,000 kg and without quick coupler, tipping cylinder, lever and connection link by an additional 1,413 kg. Weights of fitted attachments (grabs, load hooks, etc.) and load accommodation attachment are to be deducted from the lift capacity values. The lift capacity of the unit is limited by its stability, the lifting capability of the hydraulic elements, or the maximum permissible lifting capacity of the load hook.

In accordance with the harmonised European Standard EN 474-5, hydraulic excavators used for lifting operations must be equipped with pipe fracture safety valves, an overload warning device, a load hook and a lift capacity chart.

LH 40 M – Equipment GSV14

Industry – Kinematic 2A

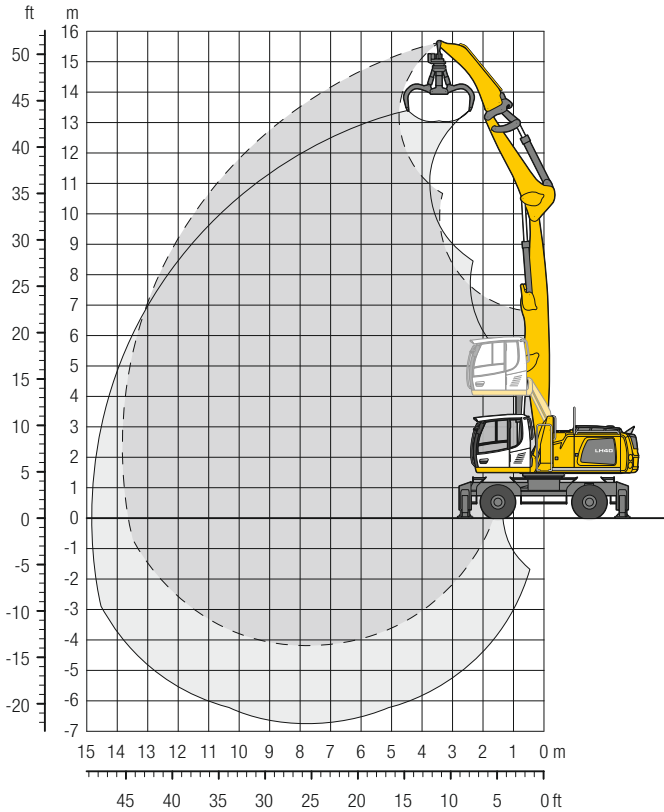

Dimensions

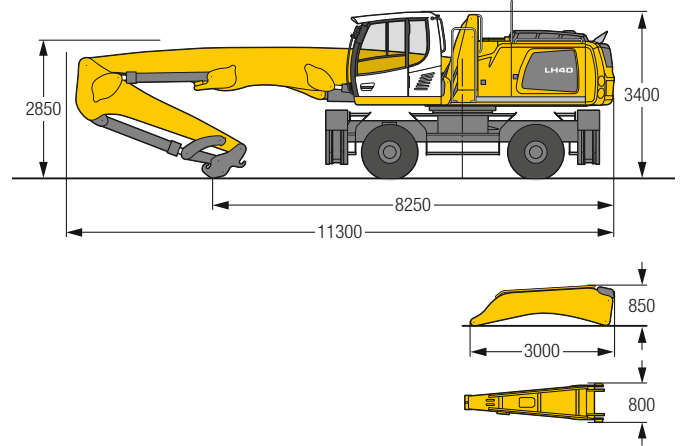

Operating weight

The operating weight includes the basic machine with 4 point outriggers, hydr. cab elevation, 8 solid tyres plus intermediate rings, straight boom 7.60 m, stick HD with tipping kinematics special 3.60 m, quick coupler SWA 66, stick extension 2.70 m and multi-tine grab GM 65 / 0.60 m³ semi-closed tines.

Weight 40,200 kg

m	Undercarriage	4.5 m		6.0 m		7.5 m		9.0 m		10.5 m		12.0 m		13.5 m		15.0 m		16.5 m		18.0 m		m		
		Stabilizers raised	4 pt. outriggers down	Stabilizers raised	4 pt. outriggers down	Stabilizers raised	4 pt. outriggers down	Stabilizers raised	4 pt. outriggers down	Stabilizers raised	4 pt. outriggers down	Stabilizers raised	4 pt. outriggers down	Stabilizers raised	4 pt. outriggers down	Stabilizers raised	4 pt. outriggers down	Stabilizers raised	4 pt. outriggers down	Stabilizers raised	4 pt. outriggers down	Stabilizers raised	4 pt. outriggers down	Stabilizers raised
15.0	Stabilizers raised	8.5*	8.5*																			7.1*	7.1*	5.2
	4 pt. outriggers down	8.5*	8.5*																			7.1*	7.1*	
13.5	Stabilizers raised			8.2*	8.2*	5.7	6.3*															4.9	5.3*	8.0
	4 pt. outriggers down			8.2*	8.2*	6.3*	6.3*															5.3*	5.3*	
12.0	Stabilizers raised					6.1	7.3*	4.0	5.4													3.2	4.4	9.8
	4 pt. outriggers down					7.3*	7.3*	6.1*	6.1*													4.5*	4.5*	
10.5	Stabilizers raised					6.3	7.1*	4.2	5.6	2.8	3.9											2.3	3.3	11.1
	4 pt. outriggers down					7.1*	7.1*	6.2*	6.2*	5.5*	5.5*											4.1*	4.1*	
9.0	Stabilizers raised					6.2	7.1*	4.2	5.6	2.8	3.9	1.8	2.7									1.7	2.7	12.1
	4 pt. outriggers down					7.1*	7.1*	6.1*	6.1*	5.4*	5.4*	4.0*	4.0*									3.8*	3.8*	
7.5	Stabilizers raised					6.0	7.2*	4.0	5.4	2.7	3.8	1.8	2.7									1.4	2.2	12.8
	4 pt. outriggers down					7.2*	7.2*	6.2*	6.2*	5.4*	5.4*	4.8*	4.8*									3.7*	3.7*	
6.0	Stabilizers raised			8.5	8.9*	5.5	7.4	3.7	5.1	2.6	3.7	1.7	2.6									1.1	1.9	13.3
	4 pt. outriggers down			8.9*	8.9*	7.4*	7.4*	6.3*	6.3*	5.4*	5.4*	4.7*	4.7*									3.6*	3.6*	
4.5	Stabilizers raised	10.6*	10.6*	7.6	9.5*	5.0	6.8	3.4	4.8	2.3	3.4	1.6	2.5	1.0	1.8							1.0	1.7	13.6
	4 pt. outriggers down	10.6*	10.6*	9.5*	9.5*	7.7*	7.7*	6.4*	6.4*	5.5*	5.5*	4.7	4.7*	3.6	3.9*							3.6	3.6*	
3.0	Stabilizers raised	10.4	13.7*	6.4	8.9	4.3	6.1	3.0	4.3	2.1	3.2	1.4	2.3	0.9	1.7							0.9	1.6	13.8
	4 pt. outriggers down	13.7*	13.7*	10.1*	10.1*	8.0*	8.0*	6.6*	6.6*	5.5*	5.5*	4.5	4.7*	3.5	3.8*							3.4	3.5*	
1.5	Stabilizers raised	8.2	12.1	5.3	7.7	3.6	5.4	2.6	3.9	1.8	2.9	1.3	2.2	0.9	1.6							0.8	1.6	13.8
	4 pt. outriggers down	14.6*	14.6*	10.6*	10.6*	8.2*	8.2*	6.6*	6.6*	5.5	5.5*	4.3	4.5*	3.5*	3.5*							3.2*	3.2*	
0	Stabilizers raised	6.7	10.5	4.4	6.8	3.1	4.8	2.2	3.5	1.6	2.7	1.1	2.0	0.8	1.6							0.8	1.6	13.6
	4 pt. outriggers down	10.7*	10.7*	10.6*	10.6*	8.2*	8.2*	6.5*	6.5*	5.2	5.3*	4.2	4.2*	2.9*	2.9*							2.7*	2.7*	
-1.5	Stabilizers raised	6.0	8.9*	3.9	6.2	2.7	4.4	2.0	3.3	1.4	2.5	1.0	1.9									0.9	1.7	13.0
	4 pt. outriggers down	8.9*	8.9*	10.0*	10.0*	7.7*	7.7*	6.1*	6.1*	4.9*	4.9*	3.6*	3.6*									2.6*	2.6*	
-3.0	Stabilizers raised	5.7	9.3*	3.6	5.9	2.5	4.2	1.8	3.1	1.3	2.4											1.1	2.1	11.5
	4 pt. outriggers down	9.3*	9.3*	8.5*	8.5*	6.7*	6.7*	5.3*	5.3*	4.0*	4.0*											3.1*	3.1*	

Height Can be slewed through 360° In longitudinal position of undercarriage Max. reach * Limited by hydr. capacity

The lift capacities on the end of the stick extension without attachment are stated in metric tons (t) and are valid on a firm, level supporting surface with blocked oscillating axle. These capacities can be slewed through 360° with the undercarriage in the transverse position. Capacities in the longitudinal position of the undercarriage (+15°) are specified over the steering axle with the stabilizers raised and over the rigid axle with the stabilizers down. Indicated loads based on the ISO 10567 standard and do not exceed 75% of tipping or 87% of hydraulic capacity. The lift capacity values indicated are attained at the corresponding operating temperature. This operating temperature is ensured by continuous movement of the boom. Weights of fitted attachments (grabs, load hooks, etc.) and load accommodation attachment are to be deducted from the lift capacity values. The lift capacity of the unit is limited by its stability, the lifting capability of the hydraulic elements, or the maximum permissible lifting capacity of the load hook.

In accordance with the harmonised European Standard EN 474-5, hydraulic excavators used for lifting operations must be equipped with pipe fracture safety valves, an overload warning device, a load hook and a lift capacity chart.

LH 50 M – Equipment GA16

Industry – Kinematic 2A

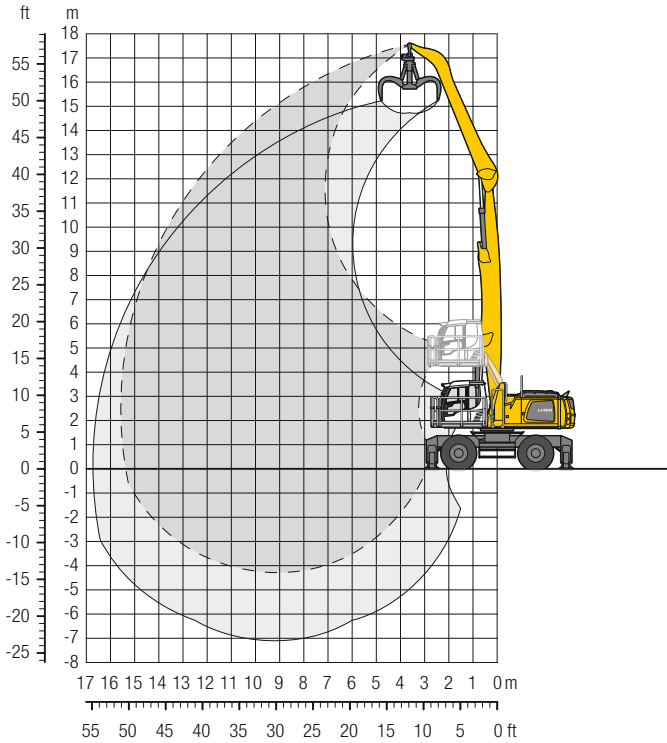

Dimensions

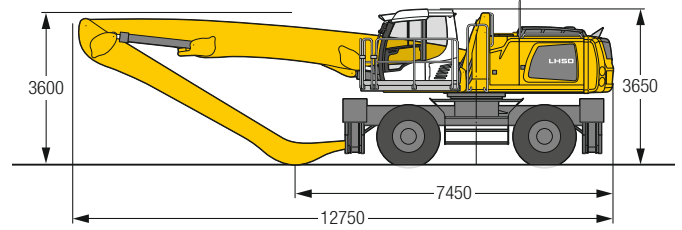

Operating weight

The operating weight includes the basic machine with 4 point outriggers, hydr. cab elevation, 4 solid tyres, straight boom 9.10 m, angled stick 6.80 m and multi-tine grab GMM 50-5/110m³ semi-closed tines.

Weight 44,000 kg

m	Undercarriage	4.5m		6.0m		7.5m		9.0m		10.5m		12.0m		13.5m		15.0m		16.5m		18.0m		Max. reach		m
		Stabilizers raised	4 pt. outriggers down	Stabilizers raised	4 pt. outriggers down	Stabilizers raised	4 pt. outriggers down	Stabilizers raised	4 pt. outriggers down	Stabilizers raised	4 pt. outriggers down	Stabilizers raised	4 pt. outriggers down	Stabilizers raised	4 pt. outriggers down	Stabilizers raised	4 pt. outriggers down	Stabilizers raised	4 pt. outriggers down	Stabilizers raised	4 pt. outriggers down	Stabilizers raised	4 pt. outriggers down	
18.0																								
16.5				7.8*	7.8*																	6.6*	6.6*	6.8
15.0				7.8*	7.8*	7.8*	7.8*	6.0	6.0*													6.6*	6.6*	9.3
13.5						8.4*	8.4*	6.3	7.4*	4.7	6.0*											5.4*	5.4*	11.1
12.0						8.3*	8.3*	6.4	7.3*	4.8	6.2	3.7	4.8									4.2	4.8*	12.4
10.5						8.3*	8.3*	7.3*	7.3*	6.6*	6.6*	5.4*	5.4*									4.8*	4.8*	13.4
9.0						8.3*	8.3*	6.4	7.3*	4.8	6.2	3.7	4.8									2.9	3.9	14.2
7.5						8.3*	8.3*	7.3*	7.3*	6.6*	6.6*	6.0*	6.0*	2.9	3.8							4.3*	4.3*	14.8
6.0						8.4*	8.5*	6.2	7.4*	4.8	6.1	3.7	4.8	5.5*	5.5*							2.6	3.5	15.2
4.5						8.1	8.8*	6.0	7.6*	4.6	5.9	3.6	4.7	6.0*	6.0*	5.5*	5.5*					4.2*	4.2*	15.5
3.0						10.2*	10.2*	8.8*	8.8*	7.6*	7.6*	6.8*	6.8*	6.1*	6.1*	5.5*	5.5*					2.3	3.2	15.6
1.5						10.5*	10.5*	10.7	11.1*	7.6	9.2*	5.7	7.3	4.4	5.7	3.5	4.6	2.8	3.7			4.1*	4.1*	15.5
0						10.5*	10.5*	11.1*	11.1*	9.2*	9.2*	7.9*	7.9*	6.9*	6.9*	6.2*	6.2*	5.5*	5.5*	4.8*	4.8*	2.2	3.0	15.4
-1.5						14.9	15.8*	9.7	12.0*	7.0	9.1	5.3	6.9	4.2	5.5	3.3	4.4	2.7	3.6			2.1	2.8	14.7
-3.0						15.8*	15.8*	12.0*	12.0*	9.7*	9.7*	8.2*	8.2*	7.1*	7.1*	6.2*	6.2*	5.6*	5.6*	4.9*	4.9*	4.2*	4.2*	13.1
-4.5						11.9*	11.9*	8.7	11.6	6.4	8.5	4.9	6.5	3.9	5.2	3.2	4.2	2.6	3.5	2.1	2.9	2.0	2.8	
						11.9*	11.9*	12.8*	12.8*	10.1*	10.1*	8.4*	8.4*	7.2*	7.2*	6.3*	6.3*	5.5*	5.5*	4.7*	4.7*	4.3*	4.3*	
						4.6*	4.6*	7.8	10.7	5.8	7.9	4.6	6.1	3.7	4.9	3.0	4.1	2.5	3.4	2.1	2.9	2.0	2.7	
						4.6*	4.6*	13.2*	13.2*	10.4*	10.4*	8.6*	8.6*	7.3*	7.3*	6.3*	6.3*	5.4*	5.4*	4.5*	4.5*	4.1*	4.1*	
						4.2*	4.2*	7.1	10.0	5.4	7.4	4.3	5.8	3.5	4.7	2.9	3.9	2.4	3.3	2.0	2.9	2.0	2.8	
						4.2*	4.2*	10.9*	10.9*	10.4*	10.4*	8.5*	8.5*	7.2*	7.2*	6.1*	6.1*	5.2*	5.2*	4.1*	4.1*	3.7*	3.7*	
						4.9*	4.9*	6.8	9.6*	5.1	7.2	4.1	5.6	3.3	4.6	2.8	3.8	2.3	3.3			2.1	2.9	
						4.9*	4.9*	9.6*	9.6*	9.9*	9.9*	8.2*	8.2*	6.8*	6.8*	5.7*	5.7*	4.7*	4.7*			3.7*	3.7*	
						6.7	9.5	5.0	7.0	4.0	5.5	3.2	4.5	2.7	3.8							2.4	3.4	
						9.8*	9.8*	8.8*	8.8*	7.4*	7.4*	6.2*	6.2*	5.0*	5.0*							4.2*	4.2*	

Height Can be slewed through 360° In longitudinal position of undercarriage Max. reach * Limited by hydr. capacity

The lift capacities on the stick end without attachment are stated in metric tons (t) and are valid on a firm, level supporting surface with blocked oscillating axle. These capacities can be slewed through 360° with the undercarriage in the transverse position. Capacities in the longitudinal position of the undercarriage (±15°) are specified over the steering axle with the stabilizers raised and over the rigid axle with the stabilizers down. Indicated loads based on the ISO 10567 standard and do not exceed 75% of tipping or 87% of hydraulic capacity. The lift capacity values indicated are attained at the corresponding operating temperature. This operating temperature is ensured by continuous movement of the boom. Weights of fitted attachments (grabs, load hooks, etc.) and load accommodation attachment are to be deducted from the lift capacity values. The lift capacity of the unit is limited by its stability, the lifting capability of the hydraulic elements, or the maximum permissible lifting capacity of the load hook.

In accordance with the harmonised European Standard EN 474-5, hydraulic excavators used for lifting operations must be equipped with pipe fracture safety valves, an overload warning device, a load hook and a lift capacity chart.

LH 50 M – Equipment GA17

Industry – Kinematic 2A

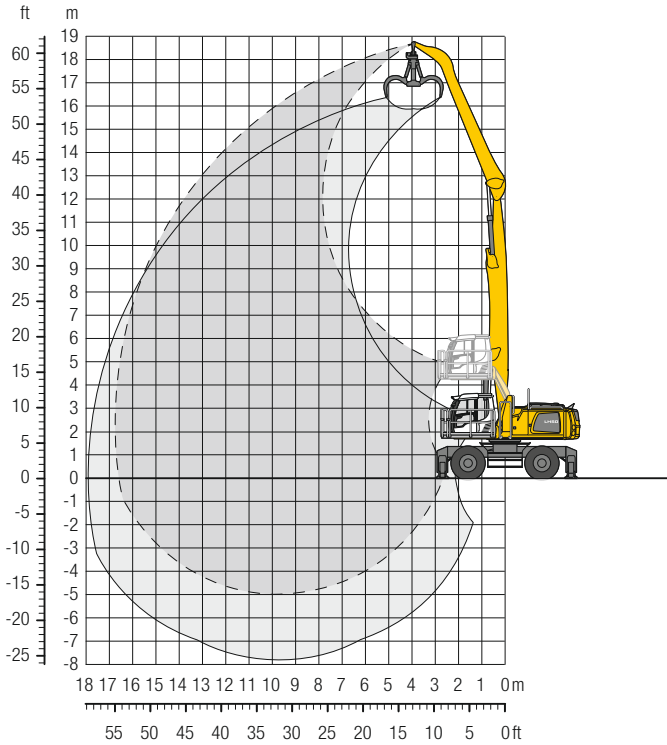

Dimensions

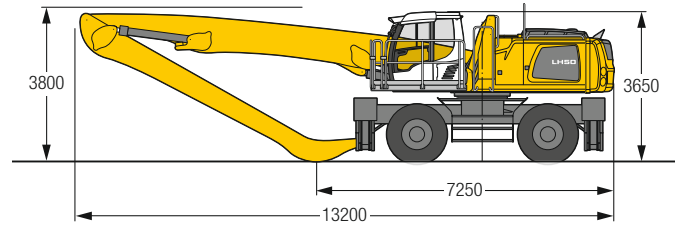

Operating weight

The operating weight includes the basic machine with 4 point outriggers, hydr. cab elevation, 4 solid tyres, straight boom 9.60m, angled stick 7.50m and multi-tine grab GMM 50-5 / 0.90 m³ semi-closed tines.

Weight 44,200 kg

m	Undercarriage	4.5m		6.0m		7.5m		9.0m		10.5m		12.0m		13.5m		15.0m		16.5m		18.0m		m		
		Stabilizers raised	4 pt. outriggers down	Stabilizers raised	4 pt. outriggers down	Stabilizers raised	4 pt. outriggers down	Stabilizers raised	4 pt. outriggers down	Stabilizers raised	4 pt. outriggers down	Stabilizers raised	4 pt. outriggers down	Stabilizers raised	4 pt. outriggers down	Stabilizers raised	4 pt. outriggers down	Stabilizers raised	4 pt. outriggers down	Stabilizers raised	4 pt. outriggers down	Stabilizers raised	4 pt. outriggers down	Stabilizers raised
18.0	Stabilizers raised			7.0*	7.0*																	6.5*	6.5*	6.4
18.0	4 pt. outriggers down			7.0*	7.0*																	6.5*	6.5*	6.4
16.5	Stabilizers raised					7.1*	7.1*	5.5*	5.5*													5.1*	5.1*	9.2
16.5	4 pt. outriggers down					7.1*	7.1*	5.5*	5.5*													5.1*	5.1*	9.2
15.0	Stabilizers raised					7.8*	7.8*	6.4	7.0*	4.7	5.6*											4.1	4.5*	11.2
15.0	4 pt. outriggers down					7.8*	7.8*	7.0*	7.0*	5.6*	5.6*											4.5*	4.5*	11.2
13.5	Stabilizers raised							6.5	7.0*	4.9	6.3	3.7	4.8									3.3	4.2*	12.7
13.5	4 pt. outriggers down							7.0*	7.0*	6.3*	6.3*	5.3*	5.3*									4.2*	4.2*	12.7
12.0	Stabilizers raised							6.6	6.9*	5.0	6.2*	3.8	4.9	2.9	3.9							2.7	3.7	13.8
12.0	4 pt. outriggers down							6.9*	6.9*	6.2*	6.2*	5.7*	5.7*	4.6*	4.6*							3.9*	3.9*	13.8
10.5	Stabilizers raised							6.5	7.0*	4.9	6.2*	3.8	4.9	3.0	3.9							2.4	3.2	14.7
10.5	4 pt. outriggers down							7.0*	7.0*	6.2*	6.2*	5.7*	5.7*	5.2*	5.2*							3.8*	3.8*	14.7
9.0	Stabilizers raised					8.1*	8.1*	6.3	7.1*	4.8	6.2	3.8	4.9	3.0	3.9	2.3	3.1					2.1	2.9	15.5
9.0	4 pt. outriggers down					8.1*	8.1*	7.1*	7.1*	6.3*	6.3*	5.7*	5.7*	5.2*	5.2*	4.8*	4.8*					3.7*	3.7*	15.5
7.5	Stabilizers raised							8.2	8.4*	6.1	7.3*	4.6	6.0	3.6	4.7	2.9	3.8	2.3	3.1			1.9	2.7	16.0
7.5	4 pt. outriggers down							8.4*	8.4*	7.3*	7.3*	6.5*	6.5*	5.8*	5.8*	5.2*	5.2*	4.8*	4.8*			3.7*	3.7*	16.0
6.0	Stabilizers raised			10.5*	10.5*			7.7	8.8*	5.7	7.3	4.4	5.7	3.5	4.6	2.8	3.7	2.2	3.0			1.8	2.5	16.4
6.0	4 pt. outriggers down			10.5*	10.5*			8.8*	8.8*	7.6*	7.6*	6.6*	6.6*	5.9*	5.9*	5.3*	5.3*	4.8*	4.8*			3.7*	3.7*	16.4
4.5	Stabilizers raised	15.1	15.3*	9.8	11.5*	7.0	9.1	5.3	6.9	4.1	5.4	3.3	4.4	2.7	3.6				1.7	2.5		1.7	2.4	16.6
4.5	4 pt. outriggers down	15.3*	15.3*	11.5*	11.5*	9.3*	9.3*	7.9*	7.9*	6.8*	6.8*	6.0*	6.0*	5.3*	5.3*	4.8*	4.8*	4.1*	4.1*			3.7*	3.7*	16.6
3.0	Stabilizers raised	12.3*	12.3*	8.6	11.6	6.3	8.4	4.8	6.5	3.8	5.1	3.1	4.2	2.5	3.4	2.1	2.9	1.7	2.4			1.7	2.4	16.7
3.0	4 pt. outriggers down	12.3*	12.3*	12.3*	12.3*	9.8*	9.8*	8.1*	8.1*	6.9*	6.9*	6.1*	6.1*	5.4*	5.4*	4.7*	4.7*	4.0*	4.0*			3.8*	3.8*	16.7
1.5	Stabilizers raised	4.1*	4.1*	7.6	10.5	5.7	7.7	4.4	6.0	3.6	4.8	2.9	4.0	2.4	3.3	2.0	2.8	1.7	2.4			1.6	2.3	16.7
1.5	4 pt. outriggers down	4.1*	4.1*	12.8*	12.8*	10.1*	10.1*	8.3*	8.3*	7.0*	7.0*	6.1*	6.1*	5.3*	5.3*	4.6*	4.6*	3.8*	3.8*			3.6*	3.6*	16.7
0	Stabilizers raised	3.5*	3.5*	6.9	9.2*	5.2	7.2	4.1	5.7	3.3	4.6	2.7	3.8	2.3	3.2	1.9	2.7	1.6	2.4			1.6	2.4	16.5
0	4 pt. outriggers down	3.5*	3.5*	9.2*	9.2*	10.1*	10.1*	8.3*	8.3*	7.0*	7.0*	6.0*	6.0*	5.2*	5.2*	4.4*	4.4*	3.3*	3.3*			3.3*	3.3*	16.5
-1.5	Stabilizers raised	4.0*	4.0*	6.5	7.9*	4.9	6.9	3.9	5.4	3.1	4.4	2.6	3.7	2.2	3.1	1.9	2.7					1.7	2.5	16.0
-1.5	4 pt. outriggers down	4.0*	4.0*	7.9*	7.9*	9.7*	9.7*	8.0*	8.0*	6.8*	6.8*	5.8*	5.8*	4.9*	4.9*	4.0*	4.0*					3.1*	3.1*	16.0
-3.0	Stabilizers raised			6.3	8.0*	4.7	6.7	3.7	5.3	3.0	4.3	2.5	3.6	2.2	3.1							1.9	2.7	14.7
-3.0	4 pt. outriggers down			8.0*	8.0*	8.9*	8.9*	7.4*	7.4*	6.3*	6.3*	5.3*	5.3*	4.3*	4.3*							3.5*	3.5*	14.7
-4.5	Stabilizers raised					4.7	6.6	3.7	5.2	3.0	4.2	2.5	3.6									2.5	3.5	12.2
-4.5	4 pt. outriggers down					7.5*	7.5*	6.4*	6.4*	5.4*	5.4*	4.4*	4.4*									4.3*	4.3*	12.2

Height Can be slewed through 360° In longitudinal position of undercarriage Max. reach * Limited by hydr. capacity

The lift capacities on the stick end without attachment are stated in metric tons (t) and are valid on a firm, level supporting surface with blocked oscillating axle. These capacities can be slewed through 360° with the undercarriage in the transverse position. Capacities in the longitudinal position of the undercarriage (+15°) are specified over the steering axle with the stabilizers raised and over the rigid axle with the stabilizers down. Indicated loads based on the ISO 10567 standard and do not exceed 75% of tipping or 87% of hydraulic capacity. The lift capacity values indicated are attained at the corresponding operating temperature. This operating temperature is ensured by continuous movement of the boom. Weights of fitted attachments (grabs, load hooks, etc.) and load accommodation attachment are to be deducted from the lift capacity values. The lift capacity of the unit is limited by its stability, the lifting capability of the hydraulic elements, or the maximum permissible lifting capacity of the load hook.

In accordance with the harmonised European Standard EN 474-5, hydraulic excavators used for lifting operations must be equipped with pipe fracture safety valves, an overload warning device, a load hook and a lift capacity chart.

LH 50 M – Equipment GA18

Industry – Kinematic 2A

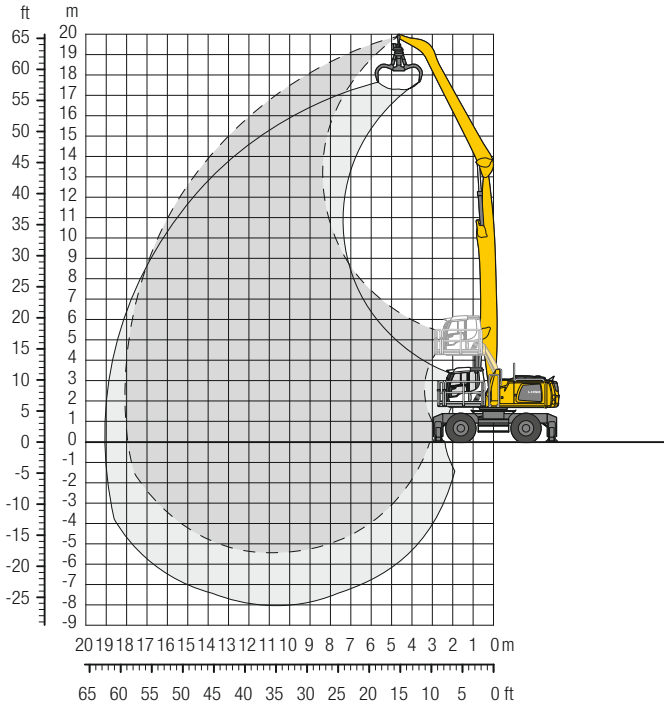

Dimensions

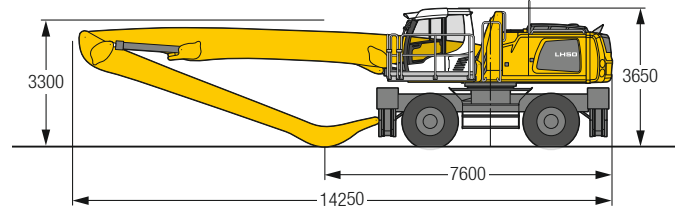

Operating weight

The operating weight includes the basic machine with 4 point outriggers, hydr. cab elevation, 4 solid tyres, straight boom 10.60m, angled stick 8.00m and multi-tine grab GM 65 / 0.60 m³ semi-closed tines.

Weight 44,500 kg

m	Undercarriage	4.5m		6.0m		7.5m		9.0m		10.5m		12.0m		13.5m		15.0m		16.5m		18.0m		m		
		Stabilizers raised	4 pt. outriggers down	Stabilizers raised	4 pt. outriggers down	Stabilizers raised	4 pt. outriggers down	Stabilizers raised	4 pt. outriggers down	Stabilizers raised	4 pt. outriggers down	Stabilizers raised	4 pt. outriggers down	Stabilizers raised	4 pt. outriggers down	Stabilizers raised	4 pt. outriggers down	Stabilizers raised	4 pt. outriggers down	Stabilizers raised	4 pt. outriggers down	Stabilizers raised	4 pt. outriggers down	Stabilizers raised
19.5	Stabilizers raised			6.2*	6.2*																	6.0*	6.0*	6.1
18.0	4 pt. outriggers down			6.2*	6.2*																	4.7*	4.7*	9.3
16.5	Stabilizers raised					6.4*	6.4*	5.1*	5.1*													4.7*	4.7*	9.3
15.0	4 pt. outriggers down					6.4*	6.4*	5.1*	5.1*													4.7*	4.7*	9.3
13.5	Stabilizers raised							6.3*	6.3*	4.8	5.2*											3.9	4.1*	11.4
12.0	4 pt. outriggers down							6.3*	6.3*	5.0	5.9*											4.1*	4.1*	11.4
10.5	Stabilizers raised							6.6	6.7*	5.9*	5.9*	3.7	4.9									3.0	3.8*	13.1
9.0	4 pt. outriggers down							6.7*	6.7*	5.9*	5.9*	5.1*	5.1*									3.8*	3.8*	13.1
7.5	Stabilizers raised							6.6*	6.6*	5.0	5.8*	3.8	5.0	2.9	3.9							2.4	3.3	14.4
6.0	4 pt. outriggers down							6.6*	6.6*	5.8*	5.8*	5.3*	5.3*	4.8*	4.8*							3.6*	3.6*	14.4
4.5	Stabilizers raised							6.6*	6.6*	5.0	5.8*	3.8	5.0	3.0	3.9	2.2	3.1					2.0	2.8	15.4
3.0	4 pt. outriggers down							6.6*	6.6*	5.8*	5.8*	5.2*	5.2*	4.7*	4.7*	4.1*	4.1*					3.5*	3.5*	15.4
1.5	Stabilizers raised							6.5	6.7*	4.9	5.9*	3.8	4.9	2.9	3.9	2.2	3.1					1.8	2.5	16.2
0	4 pt. outriggers down							6.7*	6.7*	5.9*	5.9*	5.2*	5.2*	4.7*	4.7*	4.3*	4.3*					3.4*	3.4*	16.2
-1.5	Stabilizers raised					7.9*	7.9*	6.3	6.8*	4.7	6.0*	3.6	4.8	2.8	3.8	2.2	3.0	1.7	2.4			1.6	2.3	16.9
-3.0	4 pt. outriggers down					7.9*	7.9*	6.8*	6.8*	6.0*	6.0*	5.3*	5.3*	4.8*	4.8*	4.3*	4.3*	3.9*	3.9*			3.3*	3.3*	16.9
-4.5	Stabilizers raised					8.0	8.2*	5.9	7.0*	4.5	5.8	3.5	4.6	2.7	3.7	2.1	3.0	1.7	2.4			1.4	2.1	17.4
-6.0	4 pt. outriggers down					8.2*	8.2*	7.0*	7.0*	6.1*	6.1*	5.4*	5.4*	4.8*	4.8*	4.3*	4.3*	3.9*	3.9*			3.3*	3.3*	17.4
-7.5	Stabilizers raised	9.8*	9.8*	10.5	10.6*	7.3	8.5*	5.4	7.1	4.2	5.5	3.2	4.3	2.6	3.5	2.0	2.8	1.6	2.3			1.3	1.9	17.7
-9.0	4 pt. outriggers down	9.8*	9.8*	10.6*	10.6*	8.5*	8.5*	7.2*	7.2*	6.2*	6.2*	5.4*	5.4*	4.8*	4.8*	4.3*	4.3*	3.9*	3.9*			3.3*	3.3*	17.7
-10.5	Stabilizers raised	13.9	15.1*	9.1	11.2*	6.5	8.6	4.9	6.5	3.8	5.1	3.0	4.1	2.4	3.3	1.9	2.7	1.5	2.2			1.2	1.9	18.0
-12.0	4 pt. outriggers down	15.1*	15.1*	11.2*	11.2*	8.9*	8.9*	7.4*	7.4*	6.3*	6.3*	5.5*	5.5*	4.9*	4.9*	4.3*	4.3*	3.8*	3.8*			3.3*	3.3*	18.0
-13.5	Stabilizers raised	5.2*	5.2*	7.7	10.6	5.7	7.8	4.4	6.0	3.4	4.7	2.7	3.8	2.2	3.1	1.8	2.6	1.4	2.2			1.1	1.8	18.1
-15.0	4 pt. outriggers down	5.2*	5.2*	11.7*	11.7*	9.2*	9.2*	7.6*	7.6*	6.4*	6.4*	5.6*	5.6*	4.9*	4.9*	4.3*	4.3*	3.8*	3.8*			3.2*	3.2*	18.1
-16.5	Stabilizers raised	2.6*	2.6*	6.5	8.8*	4.9	7.0	3.9	5.5	3.1	4.4	2.5	3.6	2.0	3.0	1.7	2.5	1.4	2.1			1.1	1.8	18.0
-18.0	4 pt. outriggers down	2.6*	2.6*	8.8*	8.8*	9.3*	9.3*	7.7*	7.7*	6.5*	6.5*	5.6*	5.6*	4.8*	4.8*	4.2*	4.2*	3.7*	3.7*	2.9*	2.9*	2.9*	2.9*	18.0
-19.5	Stabilizers raised	2.6*	2.6*	5.7	6.1*	4.4	6.4	3.5	5.0	2.8	4.1	2.3	3.4	1.9	2.8	1.6	2.4	1.3	2.0			1.1	1.8	17.9
-21.0	4 pt. outriggers down	2.6*	2.6*	6.1*	6.1*	9.2*	9.2*	7.6*	7.6*	6.4*	6.4*	5.5*	5.5*	4.7*	4.7*	4.1*	4.1*	3.5*	3.5*			2.7*	2.7*	17.9
-22.5	Stabilizers raised	3.1*	3.1*	5.3	5.7*	4.0	6.0	3.2	4.7	2.6	3.9	2.1	3.2	1.8	2.7	1.5	2.3	1.2	2.0			1.1	1.8	17.6
-24.0	4 pt. outriggers down	3.1*	3.1*	5.7*	5.7*	8.8*	8.8*	7.3*	7.3*	6.2*	6.2*	5.3*	5.3*	4.5*	4.5*	3.8*	3.8*	3.1*	3.1*			2.4*	2.4*	17.6
-25.5	Stabilizers raised			5.2	6.0*	3.8	5.8	3.0	4.6	2.5	3.7	2.0	3.1	1.7	2.6	1.4	2.2					1.2	2.0	16.4
-27.0	4 pt. outriggers down			6.0*	6.0*	8.0*	8.0*	6.7*	6.7*	5.7*	5.7*	4.9*	4.9*	4.1*	4.1*	3.4*	3.4*					2.6*	2.6*	16.4
-28.5	Stabilizers raised					3.8	5.8	2.9	4.5	2.4	3.6	2.0	3.0	1.7	2.6							1.5	2.3	14.4
-30.0	4 pt. outriggers down					6.7*	6.7*	5.8*	5.8*	5.0*	5.0*	4.2*	4.2*	3.5*	3.5*							3.0*	3.0*	14.4

Height Can be slewed through 360° In longitudinal position of undercarriage Max. reach * Limited by hydr. capacity

The lift capacities on the stick end without attachment are stated in metric tons (t) and are valid on a firm, level supporting surface with blocked oscillating axle. These capacities can be slewed through 360° with the undercarriage in the transverse position. Capacities in the longitudinal position of the undercarriage (+15°) are specified over the steering axle with the stabilizers raised and over the rigid axle with the stabilizers down. Indicated loads based on the ISO 10567 standard and do not exceed 75% of tipping or 87% of hydraulic capacity. The lift capacity values indicated are attained at the corresponding operating temperature. This operating temperature is ensured by continuous movement of the boom. Weights of fitted attachments (grabs, load hooks, etc.) and load accommodation attachment are to be deducted from the lift capacity values. The lift capacity of the unit is limited by its stability, the lifting capability of the hydraulic elements, or the maximum permissible lifting capacity of the load hook.

In accordance with the harmonised European Standard EN 474-5, hydraulic excavators used for lifting operations must be equipped with pipe fracture safety valves, an overload warning device, a load hook and a lift capacity chart.

LH 50 M – Equipment AF16

Industry – Kinematic 2D

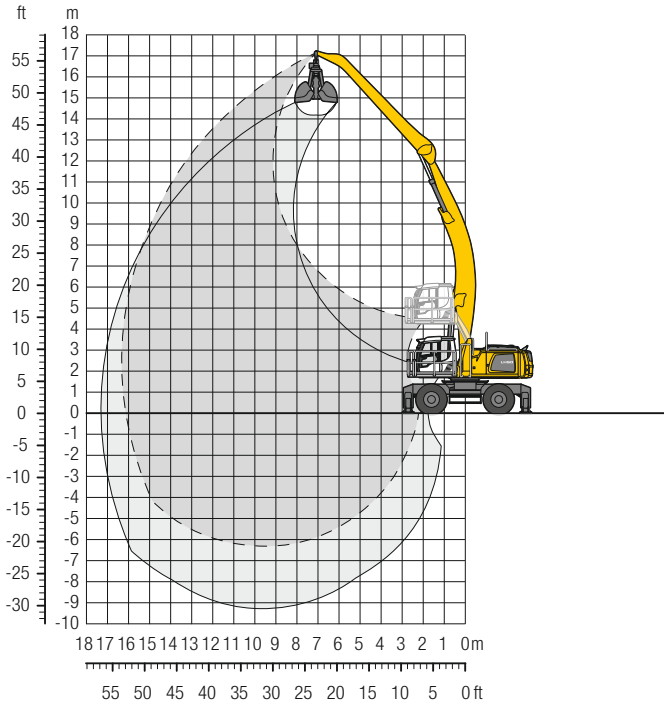

Dimensions

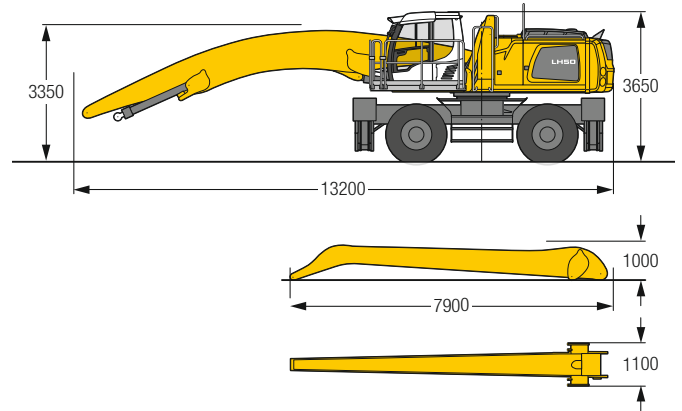

Operating weight

The operating weight includes the basic machine with 4 point outriggers, hydr. cab elevation, 4 solid tyres, angled boom 9.60 m, flat angled stick 7.50 m and grab for loose material GMZ 40 / 1.50 m³.

Weight 44,500 kg

m	Undercarriage	4.5m		6.0m		7.5m		9.0m		10.5m		12.0m		13.5m		15.0m		16.5m		18.0m		Max. reach		m
		Stabilizers raised	4 pt. outriggers down	Stabilizers raised	4 pt. outriggers down	Stabilizers raised	4 pt. outriggers down	Stabilizers raised	4 pt. outriggers down	Stabilizers raised	4 pt. outriggers down	Stabilizers raised	4 pt. outriggers down	Stabilizers raised	4 pt. outriggers down	Stabilizers raised	4 pt. outriggers down	Stabilizers raised	4 pt. outriggers down	Stabilizers raised	4 pt. outriggers down	Stabilizers raised	4 pt. outriggers down	
18.0	Stabilizers raised																							
18.0	4 pt. outriggers down																							
16.5	Stabilizers raised							5.7*	5.7*													4.8*	4.8*	8.2
16.5	4 pt. outriggers down							4.8*	4.8*													4.3*	4.3*	10.4
15.0	Stabilizers raised							6.0*	6.0*	5.1	5.5*											3.9	4.0*	12.0
15.0	4 pt. outriggers down							6.0*	6.0*	5.5*	5.5*											4.0*	4.0*	12.0
13.5	Stabilizers raised									5.2	5.4*	4.0	5.0*									3.2	3.8*	13.2
13.5	4 pt. outriggers down									5.4*	5.4*	5.0*	5.0*									3.8*	3.8*	13.2
12.0	Stabilizers raised							6.0*	6.0*	5.1	5.4*	4.0	5.0*	3.1	4.0							2.7	3.6	14.1
12.0	4 pt. outriggers down							6.0*	6.0*	5.4*	5.4*	5.0*	5.0*	4.7*	4.7*							3.7	3.7*	14.1
10.5	Stabilizers raised							6.1*	6.1*	5.0	5.5*	3.9	5.0	3.0	4.0							2.4	3.2	14.9
10.5	4 pt. outriggers down							6.1*	6.1*	5.5*	5.5*	5.0*	5.0*	4.7*	4.7*							3.7*	3.7*	14.9
9.0	Stabilizers raised							6.3	6.4*	4.8	5.7*	3.8	4.9	3.0	3.9	2.3	3.2					2.2	2.9	15.5
9.0	4 pt. outriggers down							6.4*	6.4*	5.7*	5.7*	5.1*	5.1*	4.7*	4.7*	4.4*	4.4*					3.7*	3.7*	15.5
7.5	Stabilizers raised					7.7*	7.7*	5.9	6.6*	4.6	5.9*	3.6	4.7	2.8	3.8	2.3	3.1					2.0	2.7	15.9
7.5	4 pt. outriggers down					7.7*	7.7*	6.6*	6.6*	5.9*	5.9*	5.3*	5.3*	4.8*	4.8*	4.4*	4.4*					3.7*	3.7*	15.9
6.0	Stabilizers raised	13.3*	13.3*	10.1*	10.1*	7.2	8.2*	5.5	7.0*	4.2	5.6	3.4	4.5	2.7	3.6	2.2	3.0					1.8	2.6	16.1
6.0	4 pt. outriggers down	13.3*	13.3*	10.1*	10.1*	8.2*	8.2*	7.0*	7.0*	6.1*	6.1*	5.4*	5.4*	4.9*	4.9*	4.4*	4.4*					3.8*	3.8*	16.1
4.5	Stabilizers raised	13.0	15.0*	8.8	11.0*	6.5	8.6	5.0	6.6	3.9	5.2	3.1	4.2	2.5	3.5	2.1	2.9					1.7	2.5	16.2
4.5	4 pt. outriggers down	15.0*	15.0*	11.0*	11.0*	8.7*	8.7*	7.3*	7.3*	6.3*	6.3*	5.5*	5.5*	4.9*	4.9*	4.4*	4.4*					3.9*	3.9*	16.2
3.0	Stabilizers raised	6.5*	6.5*	7.7	10.6	5.8	7.9	4.5	6.1	3.6	4.9	2.9	4.0	2.4	3.3	2.0	2.8					1.7	2.4	16.2
3.0	4 pt. outriggers down	6.5*	6.5*	11.7*	11.7*	9.2*	9.2*	7.6*	7.6*	6.5*	6.5*	5.6*	5.6*	5.0*	5.0*	4.4*	4.4*					4.0*	4.0*	16.2
1.5	Stabilizers raised	5.2*	5.2*	6.9	9.8	5.2	7.3	4.1	5.7	3.3	4.6	2.7	3.8	2.3	3.2	1.9	2.7					1.7	2.4	16.0
1.5	4 pt. outriggers down	5.2*	5.2*	11.4*	11.4*	9.5*	9.5*	7.8*	7.8*	6.6*	6.6*	5.7*	5.7*	5.0*	5.0*	4.4*	4.4*					3.9*	3.9*	16.0
0	Stabilizers raised	5.3*	5.3*	6.4	9.2	4.8	6.9	3.8	5.4	3.1	4.4	2.6	3.6	2.2	3.1	1.8	2.6					1.7	2.5	15.7
0	4 pt. outriggers down	5.3*	5.3*	9.4*	9.4*	9.5*	9.5*	7.8*	7.8*	6.6*	6.6*	5.6*	5.6*	4.9*	4.9*	4.2*	4.2*					3.8*	3.8*	15.7
-1.5	Stabilizers raised	5.8*	5.8*	6.1	9.0	4.6	6.6	3.6	5.2	3.0	4.2	2.5	3.5	2.1	3.0	1.8	2.6					1.8	2.5	15.2
-1.5	4 pt. outriggers down	5.8*	5.8*	9.0*	9.0*	9.1*	9.1*	7.6*	7.6*	6.4*	6.4*	5.4*	5.4*	4.6*	4.6*	3.8*	3.8*					3.6*	3.6*	15.2
-3.0	Stabilizers raised			6.1	8.9	4.5	6.5	3.5	5.1	2.9	4.2	2.4	3.5	2.1	3.0							1.9	2.7	14.4
-3.0	4 pt. outriggers down			9.2*	9.2*	8.4*	8.4*	7.0*	7.0*	5.9*	5.9*	5.0*	5.0*	4.1*	4.1*							3.5*	3.5*	14.4
-4.5	Stabilizers raised							3.5	5.1	2.9	4.1											2.5	3.7	11.6
-4.5	4 pt. outriggers down							6.1*	6.1*	5.2*	5.2*											4.5*	4.5*	11.6

Height Can be slewed through 360° In longitudinal position of undercarriage Max. reach * Limited by hydr. capacity

The lift capacities on the stick end without attachment are stated in metric tons (t) and are valid on a firm, level supporting surface with blocked oscillating axle. These capacities can be slewed through 360° with the undercarriage in the transverse position. Capacities in the longitudinal position of the undercarriage (+15°) are specified over the steering axle with the stabilizers raised and over the rigid axle with the stabilizers down. Indicated loads based on the ISO 10567 standard and do not exceed 75% of tipping or 87% of hydraulic capacity. The lift capacity values indicated are attained at the corresponding operating temperature. This operating temperature is ensured by continuous movement of the boom. Weights of fitted attachments (grabs, load hooks, etc.) and load accommodation attachment are to be deducted from the lift capacity values. The lift capacity of the unit is limited by its stability, the lifting capability of the hydraulic elements, or the maximum permissible lifting capacity of the load hook.

In accordance with the harmonised European Standard EN 474-5, hydraulic excavators used for lifting operations must be equipped with pipe fracture safety valves, an overload warning device, a load hook and a lift capacity chart.

LH 50 M – Equipment GA13

Industry – Kinematic 2A

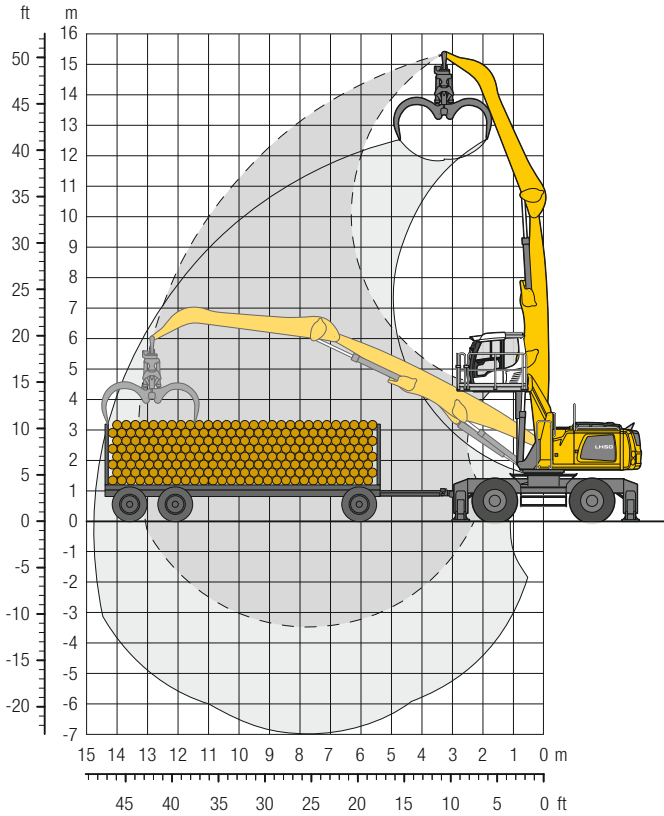

Dimensions

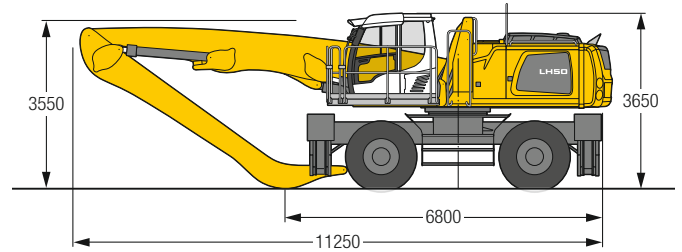

Operating weight

The operating weight includes the basic machine with 4 point outriggers, hydr. cab elevation, 4 pneumatic tyres, straight boom 7.60m, angled stick 6.00m and wood grab GMH 40 /1.90m².

Weight 42,100 kg

m	Undercarriage	4.5m		6.0m		7.5m		9.0m		10.5m		12.0m		13.5m		15.0m		16.5m		18.0m		m		
		Stabilizers raised	4 pt. outriggers down	Stabilizers raised	4 pt. outriggers down	Stabilizers raised	4 pt. outriggers down	Stabilizers raised	4 pt. outriggers down	Stabilizers raised	4 pt. outriggers down	Stabilizers raised	4 pt. outriggers down	Stabilizers raised	4 pt. outriggers down	Stabilizers raised	4 pt. outriggers down	Stabilizers raised	4 pt. outriggers down	Stabilizers raised	4 pt. outriggers down			
15.0	Stabilizers raised	8.9*	8.9*																			8.7*	8.7*	4.6
	4 pt. outriggers down	8.9*	8.9*																			8.7*	8.7*	
13.5	Stabilizers raised			9.1*	9.1*	6.6*	6.6*															6.5*	6.5*	7.5
	4 pt. outriggers down			9.1*	9.1*	6.6*	6.6*															6.5*	6.5*	
12.0	Stabilizers raised					8.0	8.9*	5.8	6.6*													5.4	5.6*	9.4
	4 pt. outriggers down					8.9*	8.9*	6.6*	6.6*													5.6*	5.6*	
10.5	Stabilizers raised					8.1	8.9*	6.0	7.6	4.5	5.8											4.3	5.2*	10.7
	4 pt. outriggers down					8.9*	8.9*	8.1*	8.1*	5.8*	5.8*											5.2*	5.2*	
9.0	Stabilizers raised					8.1	8.9*	6.0	7.6	4.6	5.8											3.7	4.8	11.7
	4 pt. outriggers down					8.9*	8.9*	8.1*	8.1*	7.4*	7.4*											5.0*	5.0*	
7.5	Stabilizers raised			10.6*	10.6*	7.9	9.2*	5.9	7.5	4.5	5.8	3.5	4.6									3.3	4.3	12.4
	4 pt. outriggers down			10.6*	10.6*	9.2*	9.2*	8.2*	8.2*	7.4*	7.4*	6.1*	6.1*									4.8*	4.8*	
6.0	Stabilizers raised			10.7	11.3*	7.6	9.6*	5.7	7.3	4.4	5.7	3.5	4.5									3.1	4.0	12.9
	4 pt. outriggers down			11.3*	11.3*	9.6*	9.6*	8.4*	8.4*	7.5*	7.5*	6.8*	6.8*									4.8*	4.8*	
4.5	Stabilizers raised	15.5	15.7*	10.0	12.3*	7.2	9.2	5.4	7.0	4.3	5.5	3.4	4.5								2.9	3.8	13.2	
	4 pt. outriggers down	15.7*	15.7*	12.3*	12.3*	10.2*	10.2*	8.8*	8.8*	7.7*	7.7*	6.8*	6.8*									4.8*	4.8*	
3.0	Stabilizers raised	13.8	17.8*	9.2	12.1	6.7	8.7	5.2	6.7	4.1	5.3	3.3	4.4								2.8	3.7	13.3	
	4 pt. outriggers down	17.8*	17.8*	13.3*	13.3*	10.7*	10.7*	9.1*	9.1*	7.8*	7.8*	6.8*	6.8*									4.9*	4.9*	
1.5	Stabilizers raised	12.4	14.0*	8.5	11.3	6.3	8.3	4.9	6.4	3.9	5.2	3.2	4.3								2.8	3.7	13.3	
	4 pt. outriggers down	14.0*	14.0*	14.1*	14.1*	11.1*	11.1*	9.2*	9.2*	7.8*	7.8*	6.6*	6.6*									5.1*	5.1*	
0	Stabilizers raised	9.2*	9.2*	7.9	10.8	6.0	7.9	4.7	6.2	3.8	5.0	3.2	4.2								2.8	3.7	13.1	
	4 pt. outriggers down	9.2*	9.2*	14.1*	14.1*	11.2*	11.2*	9.2*	9.2*	7.6*	7.6*	6.2*	6.2*									4.9*	4.9*	
-1.5	Stabilizers raised	9.1*	9.1*	7.7	10.5	5.7	7.7	4.5	6.1	3.7	4.9	3.1	4.2								3.1	4.1	12.1	
	4 pt. outriggers down	9.1*	9.1*	13.3*	13.3*	10.6*	10.6*	8.6*	8.6*	7.0*	7.0*	5.3*	5.3*									5.2*	5.2*	
-3.0	Stabilizers raised			7.6	10.4	5.7	7.6	4.5	6.0													4.0	5.3	9.9
	4 pt. outriggers down			11.3*	11.3*	9.2*	9.2*	7.5*	7.5*													6.4*	6.4*	
-4.5	Stabilizers raised																							
	4 pt. outriggers down																							

Height Can be slewed through 360° In longitudinal position of undercarriage Max. reach * Limited by hydr. capacity

The lift capacities on the stick end without attachment are stated in metric tons (t) and are valid on a firm, level supporting surface with blocked oscillating axle. These capacities can be slewed through 360° with the undercarriage in the transverse position. Capacities in the longitudinal position of the undercarriage (+15°) are specified over the steering axle with the stabilizers raised and over the rigid axle with the stabilizers down. Indicated loads based on the ISO 10567 standard and do not exceed 75% of tipping or 87% of hydraulic capacity. The lift capacity values indicated are attained at the corresponding operating temperature. This operating temperature is ensured by continuous movement of the boom. Weights of fitted attachments (grabs, load hooks, etc.) and load accommodation attachment are to be deducted from the lift capacity values. The lift capacity of the unit is limited by its stability, the lifting capability of the hydraulic elements, or the maximum permissible lifting capacity of the load hook.

In accordance with the harmonised European Standard EN 474-5, hydraulic excavators used for lifting operations must be equipped with pipe fracture safety valves, an overload warning device, a load hook and a lift capacity chart.

LH 50 M – Equipment GKG14

Industry – Kinematic 2A

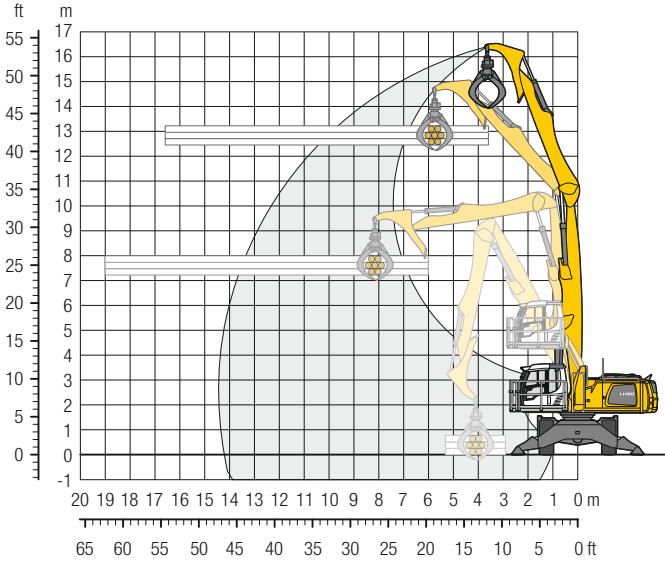

Dimensions

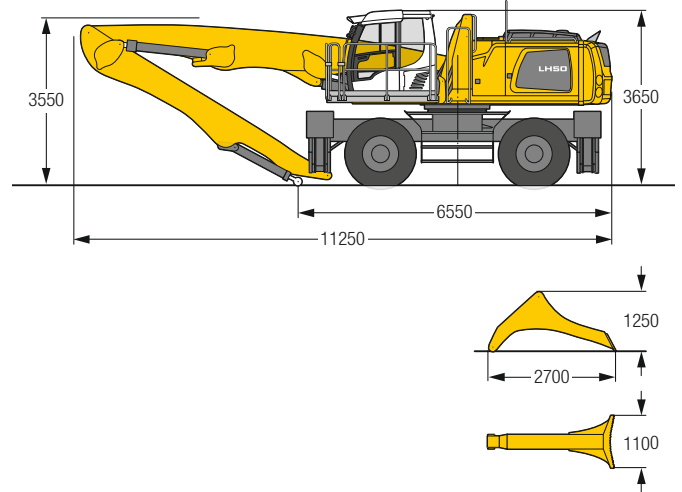

Operating weight

The operating weight includes the basic machine with 4 point outriggers, hydr. cab elevation, 4 solid tyres, straight boom 7.60 m, stick 5.80 m with counterweight and wood grab 0.70 m².

Weight	43,400 kg
--------	-----------

m	Undercarriage	4.5 m		6.0 m		7.5 m		9.0 m		10.5 m		12.0 m		13.5 m		15.0 m		16.5 m		18.0 m		m		
		Stabilizers raised	4 pt. outriggers down	Stabilizers raised	4 pt. outriggers down	Stabilizers raised	4 pt. outriggers down	Stabilizers raised	4 pt. outriggers down	Stabilizers raised	4 pt. outriggers down	Stabilizers raised	4 pt. outriggers down	Stabilizers raised	4 pt. outriggers down	Stabilizers raised	4 pt. outriggers down	Stabilizers raised	4 pt. outriggers down	Stabilizers raised	4 pt. outriggers down	Stabilizers raised	4 pt. outriggers down	Stabilizers raised
15.0	Stabilizers raised			7.6*	7.6*																	5.6*	5.6*	7.3
	4 pt. outriggers down			7.6*	7.6*																	5.6*	5.6*	7.3
13.5	Stabilizers raised					7.3*	7.3*	5.5*	5.5*													4.6*	4.6*	9.4
	4 pt. outriggers down					7.3*	7.3*	5.5*	5.5*													4.6*	4.6*	9.4
12.0	Stabilizers raised					7.9*	7.9*	6.0*	7.0*	4.4*	5.1*											4.0*	4.1*	10.9
	4 pt. outriggers down					7.9*	7.9*	7.0*	7.0*	5.1*	5.1*											4.1*	4.1*	10.9
10.5	Stabilizers raised					7.7*	7.7*	6.1*	7.0*	4.5*	5.8*	3.3*	4.0*									3.3*	3.8*	12.1
	4 pt. outriggers down					7.7*	7.7*	7.0*	7.0*	6.5*	6.5*	4.0*	4.0*									3.8*	3.8*	12.1
9.0	Stabilizers raised					7.8*	7.8*	6.1*	7.0*	4.5*	5.8*	3.4*	4.5*									2.8*	3.6*	12.9
	4 pt. outriggers down					7.8*	7.8*	7.0*	7.0*	6.4*	6.4*	5.7*	5.7*									3.6*	3.6*	12.9
7.5	Stabilizers raised					8.0*	8.0*	5.9*	7.1*	4.4*	5.8*	3.4*	4.5*	2.6*	3.5*							2.5*	3.5*	13.6
	4 pt. outriggers down					8.0*	8.0*	7.1*	7.1*	6.5*	6.5*	5.9*	5.9*	3.8*	3.8*							3.5*	3.5*	13.6
6.0	Stabilizers raised					7.8*	8.4*	5.7*	7.3*	4.3*	5.6*	3.3*	4.4*	2.6*	3.5*							2.3*	3.2*	14.0
	4 pt. outriggers down					8.4*	8.4*	7.4*	7.4*	6.6*	6.6*	6.0*	6.0*	5.1*	5.1*							3.5*	3.5*	14.0
4.5	Stabilizers raised			10.5	10.7*	7.3*	9.0*	5.4*	7.0*	4.1*	5.4*	3.2*	4.3*	2.5*	3.4*							2.2*	3.0*	14.3
	4 pt. outriggers down			10.7*	10.7*	9.0*	9.0*	7.7*	7.7*	6.8*	6.8*	6.1*	6.1*	5.4*	5.4*							3.5*	3.5*	14.3
3.0	Stabilizers raised	14.9	15.4*	9.5	11.8*	6.8	8.9	5.0	6.7	3.9	5.2	3.0	4.1	2.4	3.3							2.1	3.0	14.4
	4 pt. outriggers down	15.4*	15.4*	11.8*	11.8*	9.6*	9.6*	8.1*	8.1*	7.0*	7.0*	6.2*	6.2*	5.3*	5.3*							3.6*	3.6*	14.4
1.5	Stabilizers raised	13.0	17.4*	8.6	11.6	6.2	8.3	4.7	6.3	3.7	4.9	2.9	4.0	2.3	3.3							2.1	2.9	14.4
	4 pt. outriggers down	17.4*	17.4*	12.8*	12.8*	10.1*	10.1*	8.4*	8.4*	7.2*	7.2*	6.2*	6.2*	5.2*	5.2*							3.7*	3.7*	14.4
0	Stabilizers raised	11.7	12.1*	7.8	10.8	5.7	7.8	4.4	6.0	3.5	4.7	2.8	3.9	2.3	3.2							2.1	3.0	14.2
	4 pt. outriggers down	12.1*	12.1*	13.3*	13.3*	10.4*	10.4*	8.5*	8.5*	7.1*	7.1*	6.0*	6.0*	4.8*	4.8*							3.9*	3.9*	14.2
-1.5	Stabilizers raised	9.3*	9.3*	7.3	10.2	5.4	7.4	4.2	5.7	3.3	4.6	2.7	3.8	2.3	3.2							2.2	3.2	13.5
	4 pt. outriggers down	9.3*	9.3*	13.1*	13.1*	10.3*	10.3*	8.4*	8.4*	6.9*	6.9*	5.6*	5.6*	4.0*	4.0*							3.9*	3.9*	13.5
-3.0	Stabilizers raised	9.3*	9.3*	7.1	10.0	5.2	7.2	4.0	5.6	3.2	4.5	2.7	3.7									2.6	3.7	12.1
	4 pt. outriggers down	9.3*	9.3*	12.0*	12.0*	9.5*	9.5*	7.7*	7.7*	6.1*	6.1*	4.6*	4.6*									4.5*	4.5*	12.1
-4.5	Stabilizers raised			5.1	7.2																	4.4	6.1	8.4
	4 pt. outriggers down			7.9*	7.9*																	6.9*	6.9*	8.4

Height Can be slewed through 360° In longitudinal position of undercarriage Max. reach * Limited by hydr. capacity

The lift capacities on the stick end without attachment are stated in metric tons (t) and are valid on a firm, level supporting surface with blocked oscillating axle. These capacities can be slewed through 360° with the undercarriage in the transverse position. Capacities in the longitudinal position of the undercarriage (±15°) are specified over the steering axle with the stabilizers raised and over the rigid axle with the stabilizers down. Indicated loads based on the ISO 10567 standard and do not exceed 75% of tipping or 87% of hydraulic capacity. The lift capacity values indicated are attained at the corresponding operating temperature. This operating temperature is ensured by continuous movement of the boom. Weights of fitted attachments (grabs, load hooks, etc.) and load accommodation attachment are to be deducted from the lift capacity values. The lift capacity of the unit is limited by its stability, the lifting capability of the hydraulic elements, or the maximum permissible lifting capacity of the load hook.

In accordance with the harmonised European Standard EN 474-5, hydraulic excavators used for lifting operations must be equipped with pipe fracture safety valves, an overload warning device, a load hook and a lift capacity chart.

LH 40 C – Equipment GA14

Industry – Kinematic 2A

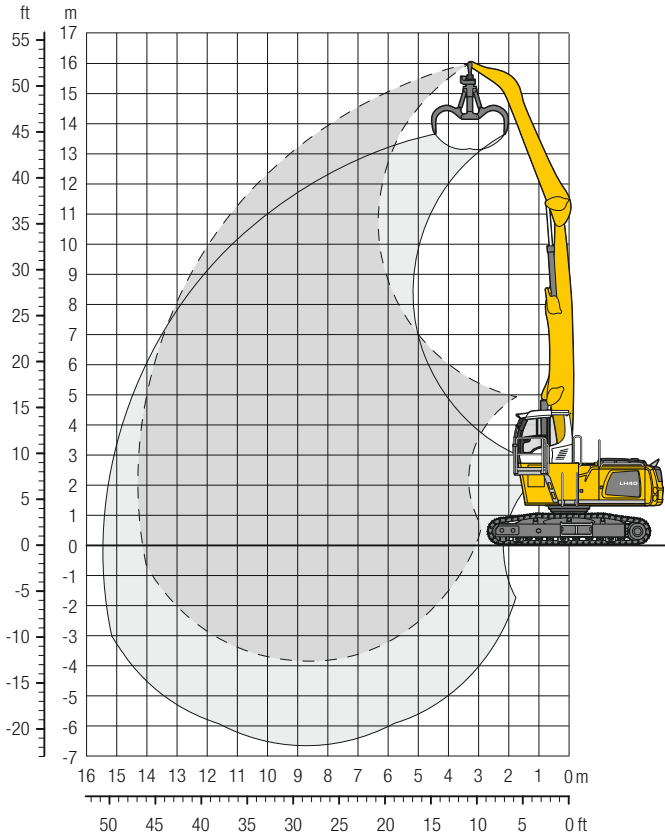

Dimensions

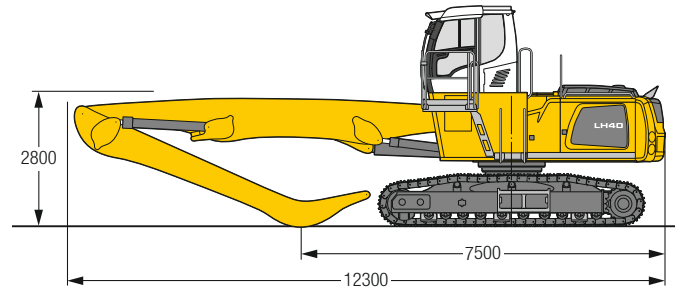

Operating weight and ground pressure

The operating weight includes the basic machine with rigid cab elevation, straight boom 8.60 m, angled stick 6.00 m and multi-tine grab GMM 50-5 / 0.90 m³ semi-closed tines.

Weight	40,100 kg
Pad width	600 mm
Ground pressure	on request

m	Undercarriage	4.5 m		6.0 m		7.5 m		9.0 m		10.5 m		12.0 m		13.5 m		15.0 m		m		
		☞	☞	☞	☞	☞	☞	☞	☞	☞	☞	☞	☞	☞	☞	☞	☞			
16.5	EW																			
15.0	EW			7.8*	7.8*													7.6*	7.6*	6.1
13.5	EW			9.7*	9.7*	8.2*	8.2*											6.2*	6.2*	8.6
12.0	EW					8.2*	8.2*	7.3*	7.3*									5.5*	5.5*	10.3
10.5	EW					8.1*	8.1*	7.2*	7.2*	6.5*	6.5*							5.2*	5.2*	11.6
9.0	EW					8.2*	8.2*	7.2*	7.2*	6.5*	6.5*	5.8*	5.8*					4.9*	4.9*	12.5
7.5	EW			10.0*	10.0*	8.4*	8.4*	7.3*	7.3*	6.5*	6.5*	5.8*	5.8*					4.8*	4.8*	13.2
6.0	EW	12.4*	12.4*	10.6*	10.6*	8.8*	8.8*	7.5*	7.5*	6.6*	6.6*	5.8	5.9*	4.7	5.2*			4.6	4.8*	13.8
4.5	EW	14.9*	14.9*	11.3*	11.3*	9.2*	9.2*	7.8*	7.8*	6.7*	6.7*	5.6	5.9*	4.7	5.1*			4.3	4.8*	14.1
3.0	EW	16.3*	16.3*	12.0*	12.0*	9.5*	9.5*	7.9*	7.9*	6.7	6.8*	5.5	5.9*	4.6	5.0*			4.2	4.5*	14.3
1.5	EW	5.7*	5.7*	12.3*	12.3*	9.7*	9.7*	8.0*	8.0*	6.5	6.8*	5.4	5.8*	4.5	4.8*			4.2*	4.2*	14.3
0	EW	4.9*	4.9*	12.1*	12.1*	9.6*	9.6*	7.8	7.9*	6.3	6.6*	5.3	5.5*	4.4*	4.4*			3.8*	3.8*	14.1
-1.5	EW	5.6*	5.6*	11.0*	11.0*	9.0*	9.0*	7.4*	7.4*	6.1*	6.1*	5.0*	5.0*					3.7*	3.7*	13.5
-3.0	EW			9.3*	9.3*	7.8*	7.8*	6.5*	6.5*	5.3*	5.3*							4.3*	4.3*	11.8
-4.5	EW																			

☞ Height ☞ Can be slewed through 360° ☞ In longitudinal position of undercarriage ☞ Max. reach * Limited by hydr. capacity

The lift capacities on the stick end without attachment are stated in metric tons (t) and can be slewed through 360° on a firm, level supporting surface. Capacities are valid for 600 mm wide triple grouser pads (resp. flat pads). Indicated loads based on the ISO 10567 standard and do not exceed 75% of tipping or 87% of hydraulic capacity. The lift capacity values indicated are attained at the corresponding operating temperature. This operating temperature is ensured by continuous movement of the boom. Weights of fitted attachments (grabs, load hooks, etc.) and load accommodation attachment are to be deducted from the lift capacity values. The lift capacity of the unit is limited by its stability, the lifting capability of the hydraulic elements, or the maximum permissible lifting capacity of the load hook.

In accordance with the harmonised European Standard EN 474-5, hydraulic excavators used for lifting operations must be equipped with pipe fracture safety valves, an overload warning device, a load hook and a lift capacity chart.

LH 40 C – Equipment GA16

Industry – Kinematic 2A

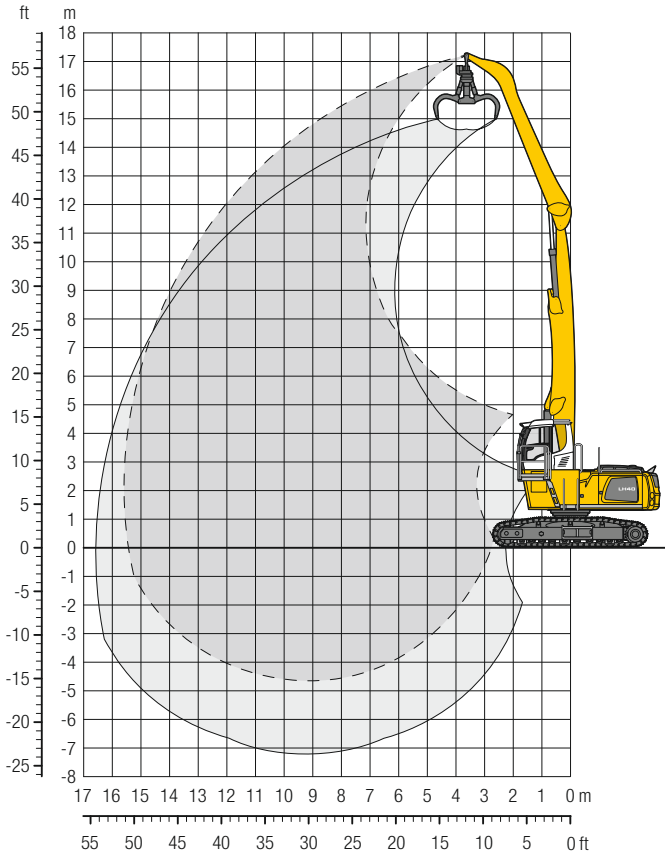

Dimensions

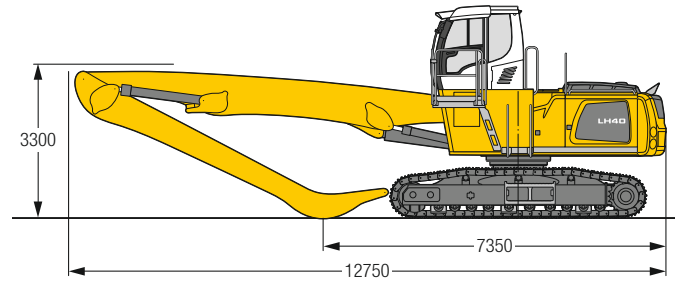

Operating weight and ground pressure

The operating weight includes the basic machine with rigid cab elevation, straight boom 9.10 m, angled stick 6.80 m and multi-tine grab GM 65 / 0.60 m³ semi-closed tines.

Weight	40,100 kg
Pad width	600 mm
Ground pressure	on request

m	Undercarriage	4.5 m		6.0 m		7.5 m		9.0 m		10.5 m		12.0 m		13.5 m		15.0 m		Max. reach		m	
		Can be slewed through 360°	In longitudinal position of undercarriage	Can be slewed through 360°	In longitudinal position of undercarriage	Can be slewed through 360°	In longitudinal position of undercarriage	Can be slewed through 360°	In longitudinal position of undercarriage	Can be slewed through 360°	In longitudinal position of undercarriage	Can be slewed through 360°	In longitudinal position of undercarriage	Can be slewed through 360°	In longitudinal position of undercarriage	Can be slewed through 360°	In longitudinal position of undercarriage	Can be slewed through 360°	In longitudinal position of undercarriage		
16.5	EW																		7.2*	7.2*	5.9
15.0	EW					7.4*	7.4*												5.7*	5.7*	8.7
13.5	EW					7.9*	7.9*	7.0*	7.0*	5.2*	5.2*								5.0*	5.0*	10.6
12.0	EW					7.8*	7.8*	6.8*	6.8*	6.1*	6.1*	4.7*	4.7*						4.6*	4.6*	12.0
10.5	EW					7.7*	7.7*	6.8*	6.8*	6.1*	6.1*	5.5*	5.5*						4.4*	4.4*	13.1
9.0	EW					7.8*	7.8*	6.8*	6.8*	6.1*	6.1*	5.5*	5.5*	4.8	5.0*				4.2*	4.2*	14.0
7.5	EW					8.1*	8.1*	7.0*	7.0*	6.2*	6.2*	5.5*	5.5*	4.8	5.0*				4.1	4.1*	14.6
6.0	EW			10.2*	10.2*	8.4*	8.4*	7.2*	7.2*	6.3*	6.3*	5.6*	5.6*	4.7	5.0*	3.9	4.3*	3.9	4.1*	15.1	
4.5	EW	14.3*	14.3*	10.8*	10.8*	8.8*	8.8*	7.4*	7.4*	6.4*	6.4*	5.6	5.6*	4.6	5.0*	3.9	4.3*	3.7	4.1*	15.4	
3.0	EW	15.6*	15.6*	11.5*	11.5*	9.1*	9.1*	7.6*	7.6*	6.5*	6.5*	5.4	5.6*	4.5	4.9*	3.8	4.2*	3.6	3.8*	15.5	
1.5	EW	5.3*	5.3*	11.9*	11.9*	9.4*	9.4*	7.7*	7.7*	6.4	6.5*	5.3	5.6*	4.4	4.8*	3.8	4.0*	3.5	3.6*	15.6	
0	EW	4.2*	4.2*	11.7*	11.7*	9.3*	9.3*	7.6*	7.6*	6.2	6.4*	5.1	5.4*	4.3	4.6*	3.6*	3.6*	3.2*	3.2*	15.4	
-1.5	EW	4.6*	4.6*	9.7*	9.7*	8.9*	8.9*	7.3*	7.3*	6.0	6.1*	5.0	5.1*	4.2*	4.2*			3.0*	3.0*	15.0	
-3.0	EW			9.5*	9.5*	7.9*	7.9*	6.6*	6.6*	5.5*	5.5*	4.5*	4.5*	3.5*	3.5*			3.4*	3.4*	13.7	
-4.5	EW							5.5*	5.5*	4.6*	4.6*							4.5*	4.5*	10.6	

Height Can be slewed through 360° In longitudinal position of undercarriage Max. reach * Limited by hydr. capacity

The lift capacities on the stick end without attachment are stated in metric tons (t) and can be slewed through 360° on a firm, level supporting surface. Capacities are valid for 600 mm wide triple grouser pads (resp. flat pads). Indicated loads based on the ISO 10567 standard and do not exceed 75% of tipping or 87% of hydraulic capacity. The lift capacity values indicated are attained at the corresponding operating temperature. This operating temperature is ensured by continuous movement of the boom. Weights of fitted attachments (grabs, load hooks, etc.) and load accommodation attachment are to be deducted from the lift capacity values. The lift capacity of the unit is limited by its stability, the lifting capability of the hydraulic elements, or the maximum permissible lifting capacity of the load hook.

In accordance with the harmonised European Standard EN 474-5, hydraulic excavators used for lifting operations must be equipped with pipe fracture safety valves, an overload warning device, a load hook and a lift capacity chart.

LH 50 M HR – Equipment AF18

Industry – Kinematic 2C

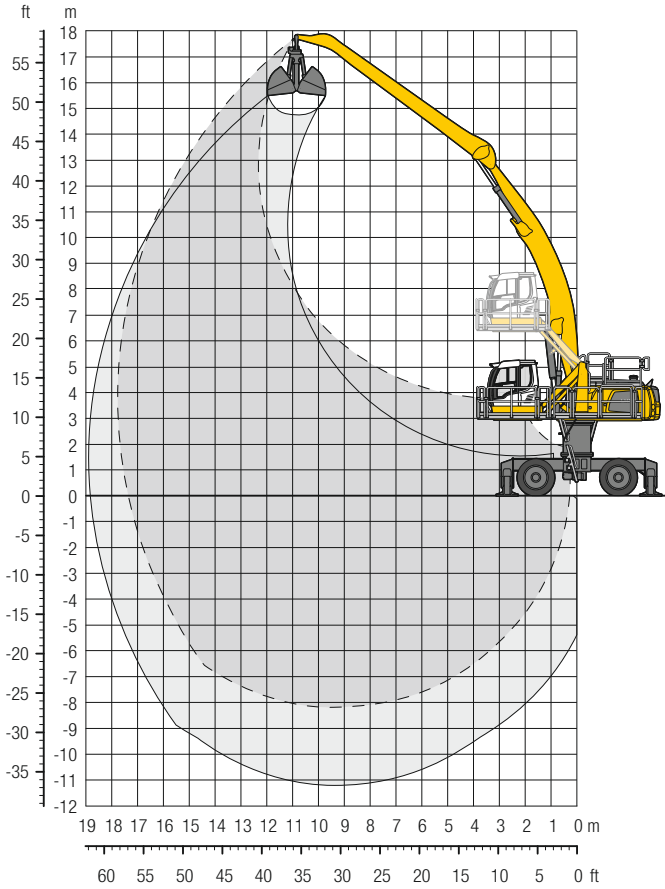

Dimensions

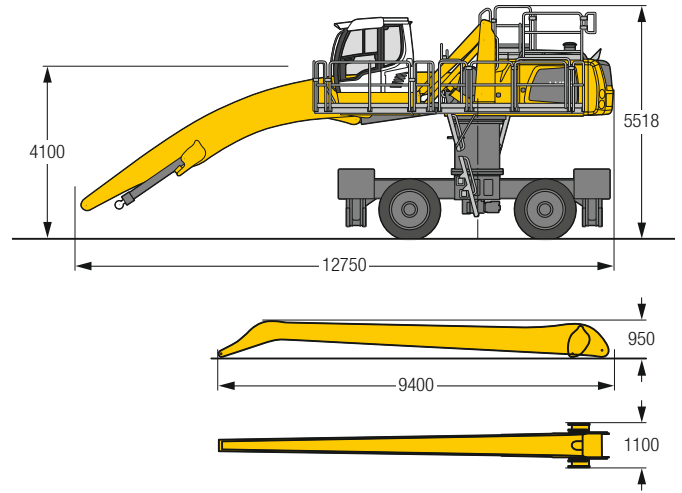

Operating weight

The operating weight includes the basic machine with 4 point outriggers, turret 1,200 mm, hydr. cab elevation, 4 solid tyres, angled boom 9.60 m, flat angled stick 9.00 m and grab for loose material GMZ 40 /1.50 m³.

Weight 45,500 kg

m	Undercarriage	4.5m		6.0m		7.5m		9.0m		10.5m		12.0m		13.5m		15.0m		16.5m		18.0m		m			
		1	2	1	2	1	2	1	2	1	2	1	2	1	2	1	2	1	2	1	2	1	2		
19.5	4 pt. outriggers down																					3.8*	3.8*	10.3	
18.0	4 pt. outriggers down																						3.4*	3.4*	12.1
16.5	4 pt. outriggers down									4.9*	4.9*	3.6*	3.6*										3.4*	3.4*	12.1
15.0	4 pt. outriggers down									5.1*	5.1*	4.7*	4.7*	3.3*	3.3*								3.2*	3.2*	13.6
13.5	4 pt. outriggers down											4.7*	4.7*	4.4*	4.4*								3.1*	3.1*	14.7
12.0	4 pt. outriggers down											4.7*	4.7*	4.3*	4.3*	3.8*	3.8*						3.0*	3.0*	15.6
10.5	4 pt. outriggers down									5.1*	5.1*	4.7*	4.7*	4.4*	4.4*	4.1*	4.1*						3.0*	3.0*	16.3
9.0	4 pt. outriggers down									5.2*	5.2*	4.8*	4.8*	4.4*	4.4*	4.1*	4.1*	3.6*	3.6*				3.0*	3.0*	16.9
7.5	4 pt. outriggers down							6.1*	6.1*	5.4*	5.4*	4.9*	4.9*	4.5*	4.5*	4.2*	4.2*	3.9*	3.9*				3.0*	3.0*	17.3
6.0	4 pt. outriggers down					7.4*	7.4*	6.4*	6.4*	5.6*	5.6*	5.1*	5.1*	4.6*	4.6*	4.2*	4.2*	3.9*	3.9*				3.0*	3.0*	17.6
4.5	4 pt. outriggers down	12.7*	12.7*	9.7*	9.7*	7.9*	7.9*	6.7*	6.7*	5.9*	5.9*	5.2*	5.2*	4.7*	4.7*	4.3*	4.3*	3.9*	3.9*				3.1*	3.1*	17.7
3.0	4 pt. outriggers down	14.4*	14.4*	10.6*	10.6*	8.5*	8.5*	7.1*	7.1*	6.1*	6.1*	5.4*	5.4*	4.8*	4.8*	4.3*	4.3*	3.9*	3.9*				3.2*	3.2*	17.7
1.5	4 pt. outriggers down	8.6*	8.6*	11.4*	11.4*	8.9*	8.9*	7.4*	7.4*	6.3*	6.3*	5.5*	5.5*	4.9*	4.9*	4.4*	4.4*	3.9*	3.9*				3.3*	3.3*	17.6
0	4 pt. outriggers down	6.0*	6.0*	11.8*	11.8*	9.3*	9.3*	7.6*	7.6*	6.4*	6.4*	5.6*	5.6*	4.9*	4.9*	4.3*	4.3*	3.8*	3.8*				3.4*	3.4*	17.4
-1.5	4 pt. outriggers down	5.7*	5.7*	10.1*	10.1*	9.3*	9.3*	7.7*	7.7*	6.5*	6.5*	5.6*	5.6*	4.9*	4.9*	4.2*	4.2*	3.6*	3.6*				3.3*	3.3*	17.0
-3.0	4 pt. outriggers down	5.9*	5.9*	9.2*	9.2*	9.1*	9.1*	7.5*	7.5*	6.4*	6.4*	5.4*	5.4*	4.7*	4.7*	4.0*	4.0*						3.2*	3.2*	16.5
-4.5	4 pt. outriggers down	6.2*	6.2*	9.1*	9.1*	8.6*	8.6*	7.1*	7.1*	6.0*	6.0*	5.1*	5.1*	4.3*	4.3*	3.5*	3.5*						3.1*	3.1*	15.6
-6.0	4 pt. outriggers down					7.6*	7.6*	6.4*	6.4*	5.4*	5.4*	4.5*	4.5*										3.8*	3.8*	13.2

Height Can be slewed through 360° In longitudinal position of undercarriage Max. reach * Limited by hydr. capacity

The lift capacities on the stick end without attachment are stated in metric tons (t) and are valid on a firm, level supporting surface with blocked oscillating axle. These capacities can be slewed through 360° with the undercarriage in the transverse position. Capacities in the longitudinal position of the undercarriage (+15°) are specified over the rigid axle with the stabilizers down. Indicated loads based on the ISO 10567 standard and do not exceed 75% of tipping or 87% of hydraulic capacity. The lift capacity values indicated are attained at the corresponding operating temperature. This operating temperature is ensured by continuous movement of the boom. Weights of fitted attachments (grabs, load hooks, etc.) and load accommodation attachment are to be deducted from the lift capacity values. The lift capacity of the unit is limited by its stability, the lifting capability of the hydraulic elements, or the maximum permissible lifting capacity of the load hook.

In accordance with the harmonised European Standard EN 474-5, hydraulic excavators used for lifting operations must be equipped with pipe fracture safety valves, an overload warning device, a load hook and a lift capacity chart.

LH 50 C HR – Equipment GA18

Industry – Kinematic 2A

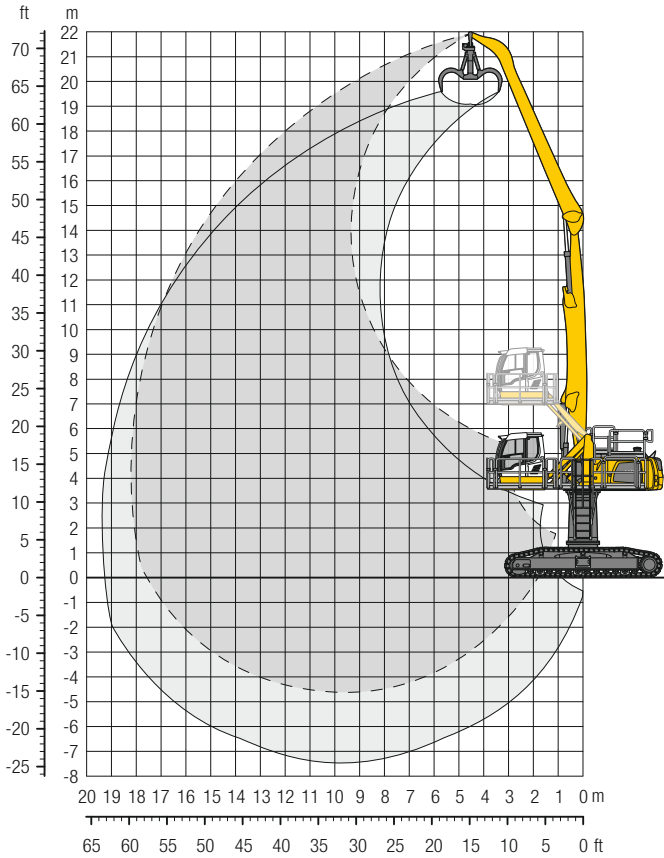

Dimensions

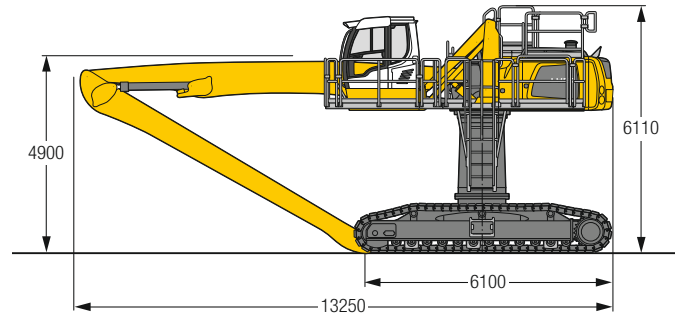

Operating weight and ground pressure

The operating weight includes the basic machine with turret 2,000 mm, hydr. cab elevation, straight boom 9.60 m, angled stick 9.00 m and multi-tine grab GMM 50-5 / 0.90 m³ semi-closed tines.

Weight	53,800 kg
Pad width	600 mm
Ground pressure	on request

m	Undercarriage	4.5m		6.0m		7.5m		9.0m		10.5m		12.0m		13.5m		15.0m		16.5m		18.0m		Max. reach		m
		SW	SW	SW	SW	SW	SW	SW	SW	SW	SW	SW	SW	SW	SW	SW	SW	SW	SW	SW	SW	SW	SW	
21.0	SW																					5.3*	5.3*	7.3
19.5	SW			6.6*	6.6*																	4.2*	4.2*	10.1
18.0	SW					6.4*	6.4*	5.4*	5.4*													3.7*	3.7*	12.0
16.5	SW							6.1*	6.1*	5.3*	5.3*	3.8*	3.8*									3.4*	3.4*	13.6
15.0	SW							6.5*	6.5*	5.8*	5.8*	5.1*	5.1*	3.5*	3.5*							3.2*	3.2*	14.8
13.5	SW									5.7*	5.7*	5.2*	5.2*	4.8*	4.8*	4.2*	4.2*					3.0*	3.0*	15.8
12.0	SW									5.7*	5.7*	5.2*	5.2*	4.8*	4.8*	4.4*	4.4*	3.0*	3.0*			2.9*	2.9*	16.5
10.5	SW							6.5*	6.5*	5.8*	5.8*	5.3*	5.3*	4.8*	4.8*	4.4*	4.4*	4.0*	4.0*			2.9*	2.9*	17.2
9.0	SW							6.7*	6.7*	6.0*	6.0*	5.4*	5.4*	4.9*	4.9*	4.5*	4.5*	4.1*	4.1*			2.9*	2.9*	17.6
7.5	SW					7.8*	7.8*	7.0*	7.0*	6.2*	6.2*	5.5*	5.5*	5.0*	5.0*	4.5*	4.5*	4.1*	4.1*			2.9*	2.9*	18.0
6.0	SW			8.6*	8.6*	8.6*	8.6*	7.3*	7.3*	6.4*	6.4*	5.6*	5.6*	5.0*	5.0*	4.5*	4.5*	4.1*	4.1*	3.3*	3.3*	2.9*	2.9*	18.2
4.5	SW	15.3*	15.3*	11.4*	11.4*	9.1*	9.1*	7.6*	7.6*	6.5*	6.5*	5.7*	5.7*	5.1*	5.1*	4.5*	4.5*	4.0*	4.0*	3.4*	3.4*	2.9*	2.9*	18.2
3.0	SW	9.3*	9.3*	12.1*	12.1*	9.5*	9.5*	7.9*	7.9*	6.7*	6.7*	5.8*	5.8*	5.1*	5.1*	4.5*	4.5*	3.9*	3.9*	3.2*	3.2*	3.0*	3.0*	18.2
1.5	SW	4.8*	4.8*	12.4*	12.4*	9.8*	9.8*	8.0*	8.0*	6.8*	6.8*	5.8*	5.8*	5.1*	5.1*	4.4*	4.4*	3.7*	3.7*	2.8*	2.8*	2.8*	2.8*	18.0
0	SW	4.4*	4.4*	9.4*	9.4*	9.7*	9.7*	7.9*	7.9*	6.7*	6.7*	5.7*	5.7*	4.9*	4.9*	4.2*	4.2*	3.4*	3.4*			2.6*	2.6*	17.6
-1.5	SW	4.7*	4.7*	8.4*	8.4*	9.2*	9.2*	7.6*	7.6*	6.4*	6.4*	5.4*	5.4*	4.6*	4.6*	3.8*	3.8*	2.8*	2.8*			2.8*	2.8*	16.5
-3.0	SW			8.4*	8.4*	8.3*	8.3*	6.9*	6.9*	5.8*	5.8*	4.9*	4.9*	4.0*	4.0*							3.2*	3.2*	14.9
-4.5	SW							5.8*	5.8*	4.8*	4.8*											4.4*	4.4*	11.3

Height Can be slewed through 360° In longitudinal position of undercarriage Max. reach * Limited by hydr. capacity

The lift capacities on the stick end without attachment are stated in metric tons (t) and can be slewed through 360° on a firm, level supporting surface. Capacities are valid for 600 mm wide flat pads. Indicated loads based on the ISO 10567 standard and do not exceed 75% of tipping or 87% of hydraulic capacity. The lift capacity values indicated are attained at the corresponding operating temperature. This operating temperature is ensured by continuous movement of the boom. Weights of fitted attachments (grabs, load hooks, etc.) and load accommodation attachment are to be deducted from the lift capacity values. The lift capacity of the unit is limited by its stability, the lifting capability of the hydraulic elements, or the maximum permissible lifting capacity of the load hook.

In accordance with the harmonised European Standard EN 474-5, hydraulic excavators used for lifting operations must be equipped with pipe fracture safety valves, an overload warning device, a load hook and a lift capacity chart.

Liebherr ERC-System

More performance, less consumption

Lowering the equipment stores energy in the ERC-System. This stored energy is then made available to the machine to provide additional engine power. When the equipment is raised the stored energy is released and is reflected in powerful, homogeneous operating cycles. The result is a clear energy saving – and, at the same time, even greater performance.

System performance

The energy recovery cylinder is a storage system which is independent of the electric motor or diesel engine. The system performance of material handling machines fitted with the ERC-System is composed of the installed engine power and the energy recovery cylinder. When the equipment is raised, energy from the ERC-System is supplied in addition to the power from the engine.

ERC-System

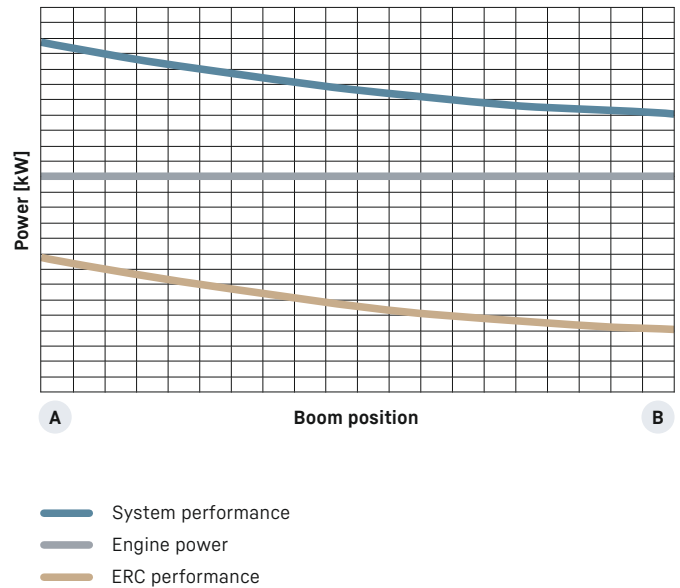

B 1. Equipment fitting raised / energy released

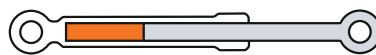

2. Lower equipment fitting / store energy
4. Raise equipment fitting / release energy



A 3. Equipment fitting lowered / energy stored

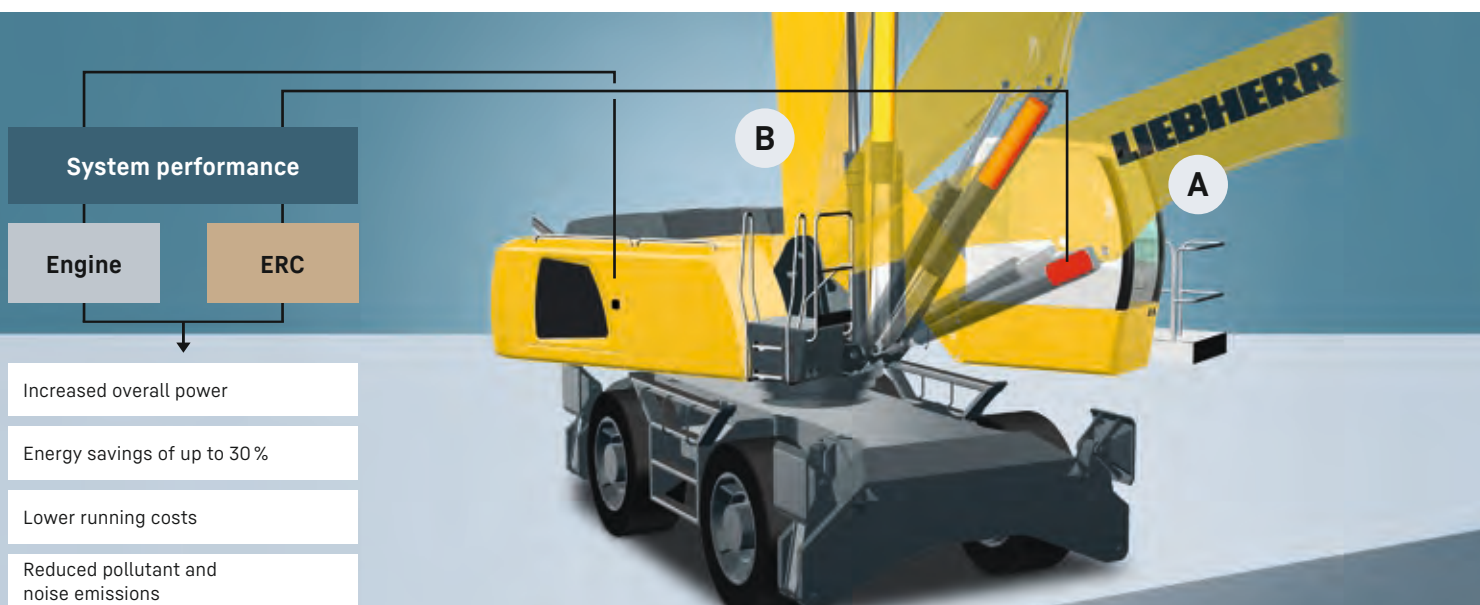

Attachments

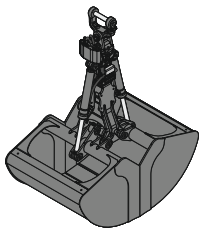

Grab for loose material

Grab model GMZ 40		Standard				Wide					
Shell specification											
Width of shells	mm	1,190	1,500	1,750	1,900	1,190	1,500	1,750	2,000	2,250	2,500
Capacity	m ³	2.10	2.50	3.00	3.50	1.20	1.50	1.75	2.00	2.25	2.50
Weight	kg	1,740	1,885	2,005	2,080	1,540	1,665	1,770	1,875	2,050	2,155

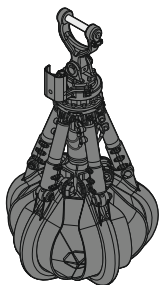

Multi-tine grab

		open		semi-closed		closed, heart-shaped				
Grab model GM 65 (5 tines)										
Capacity	m ³	0.40	0.60	0.40	0.60	0.40	0.60			
Weight	kg	1,175	1,310	1,350	1,490	1,365	1,605			
Grab model GM 69 (4 tines)										
Capacity	m ³	0.80	1.10	0.80	1.10	0.80	1.10			
Weight	kg	1,390	1,435	1,580	1,695	1,945	2,100			
Grab model GMM 50-5 (5 tines)										
Capacity	m ³	0.70	0.90	1.10	0.70	0.90	1.10			
Weight	kg	1,620	1,760	1,770	1,695	1,845	1,875	1,790	1,950	1,955

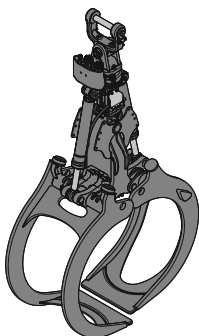

Wood grab

Grab model GMH 40 – round overlapping (vertical cylinders)						
Size	m ²	1.00	1.30	1.50	1.70	1.90
Cutting width	mm	810	810	810	810	810
Height of grab, closed	mm	2,576	2,679	2,723	2,816	2,900
Weight	kg	1,575	1,605	1,655	1,660	1,790

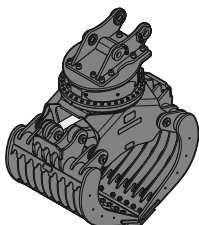

Sorting grab

		ribbed	perforated	ribbed	perforated	ribbed	perforated
Grab model SG 30B							
Width of shells	mm	1,000	1,000	1,200	1,200	1,400	1,400
Capacity	m ³	0.75	0.85	0.90	1.00	1.05	1.15
Max. closing force	kN	80	80	80	80	80	80
Weight incl. quick coupler mounting SWA 66	kg	1,880	1,785	1,970	1,845	2,065	1,905



Load hook

Max. load	t	12.5
Height with suspension	mm	930
Weight	kg	135

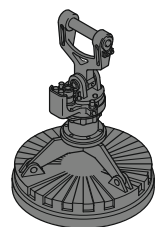



Magnet devices / lifting magnets

Generator	kW	13/20	13/20
Electromagnet with suspension			
Power	kW	8.8	10
Diameter of magnet	mm	1,250	1,350
Weight	kg	1,310*	1,700*

* only magnet plate

Equipment

 Undercarriage	40 M	50 M	40 C	50 M HR	50 C HR
Support assistant	+	+		+	
Axles with increased traction (reduced speed)		+			
Trailer coupling	+	+			
Track pads, variants			+		+
Individual control outriggers	+	+		•	
Three-piece chain guide			+		•
Shuttle axle lock, automatic	•	•		•	
Outrigger monitoring system	+	+		+	
Tyres, variants	+	+		+	
Trailing cable ²⁾	•		•		
Protection for piston rods, outriggers	+	+		+	
Two storage compartments ¹⁾	•	•			
One storage compartment ²⁾	•				
Cable reel system ²⁾	+				

 Uppercarriage	40 M	50 M	40 C	50 M HR	50 C HR
Uppercarriage right side light, 1 piece, LED	•	•	•	•	•
Uppercarriage rear light, 2 pieces, LED	+	+	+		
Uppercarriage underneath rear light, 1 piece, LED				+	+
Tank refilling pump fuel ¹⁾	+	+	+	+	+
Railing on uppercarriage	+	+	+	•	•
Generator	+	+	+	+	+
Main battery switch for electrical system	•	•	•	•	•
Amber beacon, at uppercarriage, LED double flash	+	+	+	+	+
Protection for headlights	+	+	+		
Protection for rear lights	+	+	+		
Tool equipment, extended	•	•	•	•	•

 Hydraulic system	40 M	50 M	40 C	50 M HR	50 C HR
Electronic pump regulation	•	•	•	•	•
Liebherr hydraulic oil from -20 °C to +40 °C	•	•	•	•	•
Liebherr hydraulic oil, biologically degradable	+	+	+	+	+
Liebherr hydraulic oil, specially for warm or cold regions	+	+	+	+	+
Magnetic rod in hydraulic tank	•	•	•	•	•
Bypass filter	+	+	+	+	+
Preheating hydraulic oil	+	+	+	+	+

 Engine	40 M	50 M	40 C	50 M HR	50 C HR
Fuel anti-theft device ¹⁾	+	+	+	+	+
Air pre-filter with dust discharge ¹⁾	+	+	+	+	+
Automatic engine shut-down (time adjustable)	+	+	+	+	+
Preheating fuel ¹⁾	+	+	+	+	+
Preheating coolant ¹⁾	+	+	+	+	+
Preheating engine oil* ¹⁾	+	+	+	+	+

 Cooling system	40 M	50 M	40 C	50 M HR	50 C HR
Reversible fan drive	+	+	+	+	+
Protective grid in front of cooler intake	•	•	•	•	•



Cab

	40 M	50 M	40 C	50 M HR	50 C HR
Stabilizer, control lever, left console	+	+		+	
Stabilizer, proportional control on left joystick	●	●		●	
Cab lights rear, halogen	+	+	+	+	+
Cab lights rear, LED	+	+	+	+	+
Cab lights front, halogen	+	+	+	+	+
Cab lights front, halogen (under rain cover)	●	●	●	●	●
Cab lights front, LED	+	+	+	+	+
Cab lights front, LED (under rain cover)	+	+	+	+	+
Armrest adjustable	●	●	●	●	●
Circular bubble level	+	+	+		●
Slewing gear brake Comfort, button on the left or right joystick	+	+	+	+	+
Driver profile, personalised (max. 5 drivers)	+	+	+	+	+
Operator's seat Comfort	●	●	●	●	●
Operator's seat Premium	+	+	+	+	+
Driving alarm (acoustic signal is emitted during travel, can be switched ON / OFF)	+	+	+	+	+
Fire extinguisher	+	+	+	+	+
Footrest	+	+	+	+	+
Horn, button on left joystick	●	●	●	●	●
Joystick steering (max. 12 km/h)	●	●		●	
Joystick and wheel steering (slim version)	+	+		+	
Cab elevation, hydraulic (LHC)	●	●	●	●	●
Cab elevation, hydraulic with tilt function (LHC)	+	+	+		
Cab elevation, rigid (LFC)	+	+	+		
Automatic air conditioning	●	●	●	●	●
Wheel steering (slim version)	+	+		+	
LiDAT, vehicle fleet management	●	●	●	●	●
Engine shut-down (emergency stop) cab ²⁾	●	●	●		
Proportional control	●	●	●	●	●
Radio Comfort, control via display with handsfree set	+	+	+	+	+
Preparation for radio installation	●	●	●	●	●
Back-up alarm (acoustic signal is emitted traveling backward, can not be switched off)	+	+		+	
Amber beacon, on cab, LED double flash	+	+	+	+	+
Windows made from impact-resistant laminated safety glass	+	+	+	●	●
Windscreen wiper, roof	+	+	+	+	+
Windshield wiper, entire windscreen	●	●	●	●	●
FOPS top guard	+	+	+	+	+
FGPS front guard, tiltable	+	+	+	+	+
Sun visor	+	+	+	+	+
Stationary air-conditioning ²⁾	●	●	●		
Left control console, folding	●	●	●	●	●



Equipment

	40 M	50 M	40 C	50 M HR	50 C HR
Boom lights, 2 pieces, halogen	●	●	●	●	●
Boom lights, 2 pieces, LED	+	+	+	+	+
Stick lights, 2 pieces, halogen	●	●	●	●	●
Stick lights, 2 pieces, LED	+	+	+	+	+
Boom shutoff (retract / extend), electronically	+	+	+	+	+
Equipment with electro-hydraulic end position control	●	●	●	●	●
AutoLift	+	+	+	+	+
Pressure warning mechanism hoist cylinder	●	●	●	●	●
ERC system	●	●	●	●	●
Filter system for attachment	+	+	+	+	+
Electronic lift limitation	+	+	+	+	+
Boom cylinder cushioning	●	●	●	●	●
Stick camera (with separate monitor), bottom side, with protection	+	+	+	+	+
Load torque limitation	+	+	+	+	+
Liebherr multi coupling system	+	+	+	+	+
Liebherr quick coupler, hydraulic	+	+	+		
Pipe fracture safety valves hoist cylinders	●	●	●	●	●
Pipe fracture safety valves stick cylinders	●	●	●	●	●
Quick coupling system Solidlink	+	+	+		
Quick coupling system MH 40B	+	+	+	+	+
Protection for piston rod, energy recovering cylinder	+	+	+	+	+
Protection for piston rods, hoist cylinder	+	+	+	+	+
Protection for piston rods, stick cylinder	+	+	+		
Stick shutoff (retract), electronically	●	●	●	●	●
Stick shutoff (retract / extend), electronically	+	+	+	+	+
Retract stick without pressure	●	●	●	●	●
Sticks with quick coupling	+	+	+	+	+
Overload warning device	+	+	+	+	+



Complete machine

	40 M	50 M	40 C	50 M HR	50 C HR
Lubrication					
Lubrication undercarriage, manually - decentralised (grease points)	●	●			
Lubrication undercarriage, manually - centralised (one grease point)	+	+		●	
Central lubrication system for uppercarriage and equipment, automatically	●	●	●	●	●
Central lubrication system for undercarriage, automatically	+	+		+	
Centralised lubrication extended for attachment	+	+	+	+	+
Special coating					
Special coating, variants	+	+	+	+	+
Monitoring					
Rear view monitoring with camera	●	●	●	●	●
Side view monitoring with camera	●	●	●	●	●

● = Standard, + = Option

* = country-dependent, ¹⁾ not with electric drive, ²⁾ only with electric drive

Options and / or special equipment, supplied by vendors other than Liebherr, are only to be installed with the knowledge and approval of Liebherr in order to retain warranty.

The Liebherr Group



Global and independent: more than 70 years of success

Liebherr was founded in 1949 when, with the development of the world's first mobile tower crane, Hans Liebherr laid the foundations for a family business now employing nearly 51,000 people and comprising over 140 companies across every continent.

The parent company is Liebherr-International AG in Bulle, Switzerland, whose associates are exclusively members of the Liebherr family.

Leaders and pioneers

Liebherr is a pioneer and its forward-looking approach has seen it make important contributions to technology history over a wide variety of industries. Employees throughout the world continue to share the courage of the founder, sharing a passion to produce innovative products and a determination to provide world-leading equipment and machinery.

Diversified portfolio

The company is one of the world's biggest construction equipment manufacturers and provides high-quality, user-oriented products and services to sectors including: earthmoving, material handling, deep foundations, mining, mobile and crawler cranes, tower cranes, concrete production and distribution, maritime cranes, aerospace and transportation, gear technology and automation, refrigeration and freezing, components and hotels.

Customised care

Liebherr solutions are characterised by precision, implementation and longevity. The company is committed to technological excellence and to providing customers with solutions that match their needs exactly. That customer focus does not end with delivery of a product but continues through a comprehensive range of back-up and support services.

www.liebherr.com

Liebherr-Hydraulikbagger GmbH

Liebherrstraße 12 • 88457 Kirchdorf/Iller, Germany • Phone +49 7354 80-0 • Fax +49 7354 80-72 94
info.lhb@liebherr.com • www.liebherr.com • www.facebook.com/LiebherrConstruction