

# ICNh 5133

Integrated fridge-freezer with  
EasyFresh and NoFrost  
◇ Plus

# LIEBHERR

Fully Integrated



 Made  
in Germany



Fully Integrated

**LIEBHERR**

# ICNh 5133

Integrated fridge-freezer with  
EasyFresh and NoFrost

◆ Plus

↑  
**178**  
↓



**G** Made  
in Germany



Type	Fixed door / Built-in appliance for integrated use
Total volume	254 l <sup>1</sup>
Total net	Fridge: 182 l / Freezer compartment: 67 l
Noise output	34 dB(A)
Frequency / voltage	50-60 Hz / 220-240 V~
Connection Rating	1.4 A 183 W
Aperture dimensions in cm (h / w / d)	177.2-178.8 / 56-57 / min. 55
<b>Controls</b>	
Type of Control	LC monochrome display, touch electronic Digital temperature display for fridge and freezer compartments
Interface	SmartDeviceBox: optional accessory (Only available in selected countries)
Door alarm	visual and acoustic
Alarm in case of malfunction	visual and acoustic
<b>Fridge compartment</b>	
Forced air system	PowerCooling with FreshAir activated charcoal filter
Door interior	Plastic door shelves with bottle holder, egg tray
VarioSafe	yes
Bottle shelf	3-bottle shelf
Interior light	LED ceiling lighting
Fruit and vegetable bins	1 EasyFresh safe on integrated drawer guide
<b>Freezer compartment</b>	
Star coding	****
Number of drawers	3 drawers, VarioSpace
IceMaker	with water tank
Ice cube capacity in 24 hours	1.2 kg
Ice cube stock	5.0 kg
Freezing capacity in 24 hours	6 kg
<b>Features</b>	
Side-by-Side concept	Side-panel heating on both sides, suitable for combination with other fridges, freezers and/or wine appliances
Door hinges	Reversible door hinging, right
Replaceable door seal	yes
EAN-Nr.	4016803117698

<sup>1</sup> In accordance with Regulation EU 2019/2016 we indicate the total volume to the nearest integer (rounded off) and the volume of the frozen compartments and refrigeration compartments to one place after the decimal point.

## Features

---



**EasyFresh**

The guarantee of market freshness in the home is our EasyFresh-Safe. Whether it's unpackaged vegetables or fruit, this ensures optimal storage for everything. Thanks to the air-tight closure, the food causes the humidity in the safe to rise. This keeps the food fresh for a long time.



**NoFrost**

When you open your freezer, you want to see frozen food – and certainly not ice and frost. NoFrost protects the freezer compartment from unwanted icing, which consumes a lot of energy and can be expensive. NoFrost means no more tedious and time-consuming defrosting of the freezer compartment, more time for other things – and saving money.



**DuoCooling**

DuoCooling uses two completely separate refrigeration circuits to ensure no air is exchanged between the fridge and freezer compartments. The food neither dries out nor is odour transferred. This means throwing less away, shopping less often, but saving more and greater enjoyment.



**Touch display**

Fingertip control: the touch display enables easy and intuitive operation of your Liebherr. All functions are clearly arranged on the display. By gently tapping a finger, for example, you can easily select the functions or check the current temperature of your refrigerator.



**SmartSteel rear wall**

The rear wall in elegant SmartSteel gives your Liebherr a stylish look and feel. Your food will also love SmartSteel as stainless steel is food-safe and hygienic. SmartSteel also reduces the visibility of fingerprints – making the appearance even more pleasing.



**IceMaker with water tank**

Whether it's for a party or a spontaneous cocktail, the integrated IceMaker means you always have enough ice cubes in stock. With the IceMaker with water tank, you simply fill the removable water tank with water. The MaxIce function allows you to produce up to 1.5 kg of ice cubes a day. The ice compartment separator helps to divide the drawer as you wish, for example, ice cubes on the left, ice cream on the right.

# Technical drawing

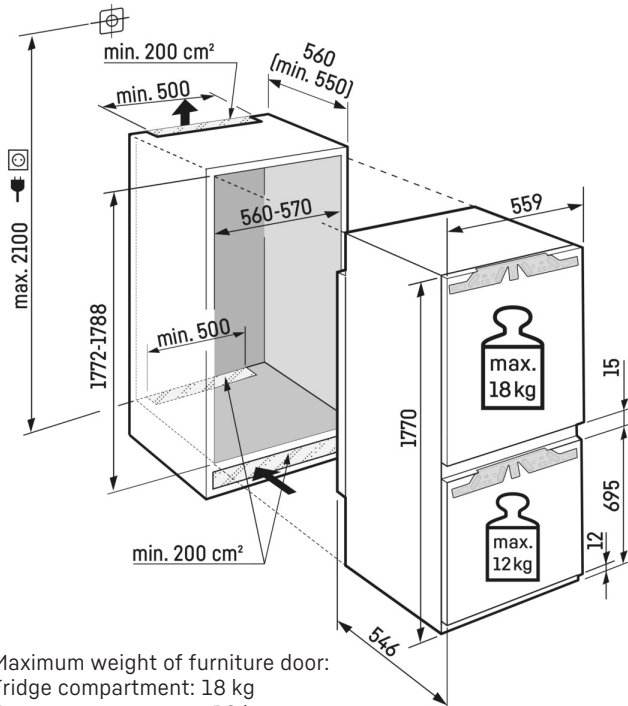

Maximum weight of furniture door:  
Fridge compartment: 18 kg  
Freezer compartment: 12 kg

Products and their details are staged for advertising purposes. Whilst every effort is made to ensure all specifications and information in this flyer are accurate, Liebherr reserves the right to make changes without notification. Where actual appliance measurements, specifications, and ratings are crucial, we recommend that the actual appliance installation instructions that accompany each appliance be checked. Liebherr will not be liable for any damage. (04.03.2025)

