

ES



LR 1200.1

LR 1004.03.08

www.liebherr.com

LIEBHERR

Grúas sobre cadenas

Concepto y características	3
Descripción técnica	6
Dimensiones	8
Dimensiones y pesos de transporte	9
Sistema de auto-montaje	14
Configuraciones de pluma	16
Pluma principal 2320.xx	18
Plumín abatible 1713.xx	20
Plumín abatible 1916.xx	26
Plumín fijo 1008.xx	32
Plumín fijo 0806.xx	35
Plumín fijo 0906.21	38

Observaciones

- Las mencionadas capacidades de carga son válidas para trabajos de elevación (corresponden según clasificación de grúas ISO 4301-1, grupo de grúas A1).
- La grúa debe estar situada sobre un terreno horizontal y firme.
- Los pesos de los implementos de elevación (tales como cables de elevación, ganchos, cuñeros etc.) se tienen que deducir de los valores de carga.
- Equipos adicionales montados en la pluma (tales como pasarelas etc.) se tienen que deducir de los valores de carga.
- Se puede preseleccionar, en el software de LML, la velocidad máxima permitida del viento quedando así reflejada en el tabla de carga.
- El radio de trabajo se mide desde el centro de la corona.
- Las capacidades de carga están indicadas en toneladas y son válidas para 360 grados de giro.
- El cálculo de estabilidad bajo la carga está basado en ISO 4305 tabla 1 + 2 + 3, valor vuelco 4°.
- Las estructuras están calculadas según EN 13001-1; EN 13001-2.
- Los últimos dígitos de las dimensiones proporcionados están redondeados (0 y 5). Estos pueden diferir de las dimensiones reales.
- Los pesos pueden variar dependiendo de la configuración de la máquina, el llenado de los tanques y el espesor de acero usado en su construcción.
- Las cifras de este folleto pueden incluir opciones, que no están dentro del suministro estándar de entrega de la máquina.

Concepto y características

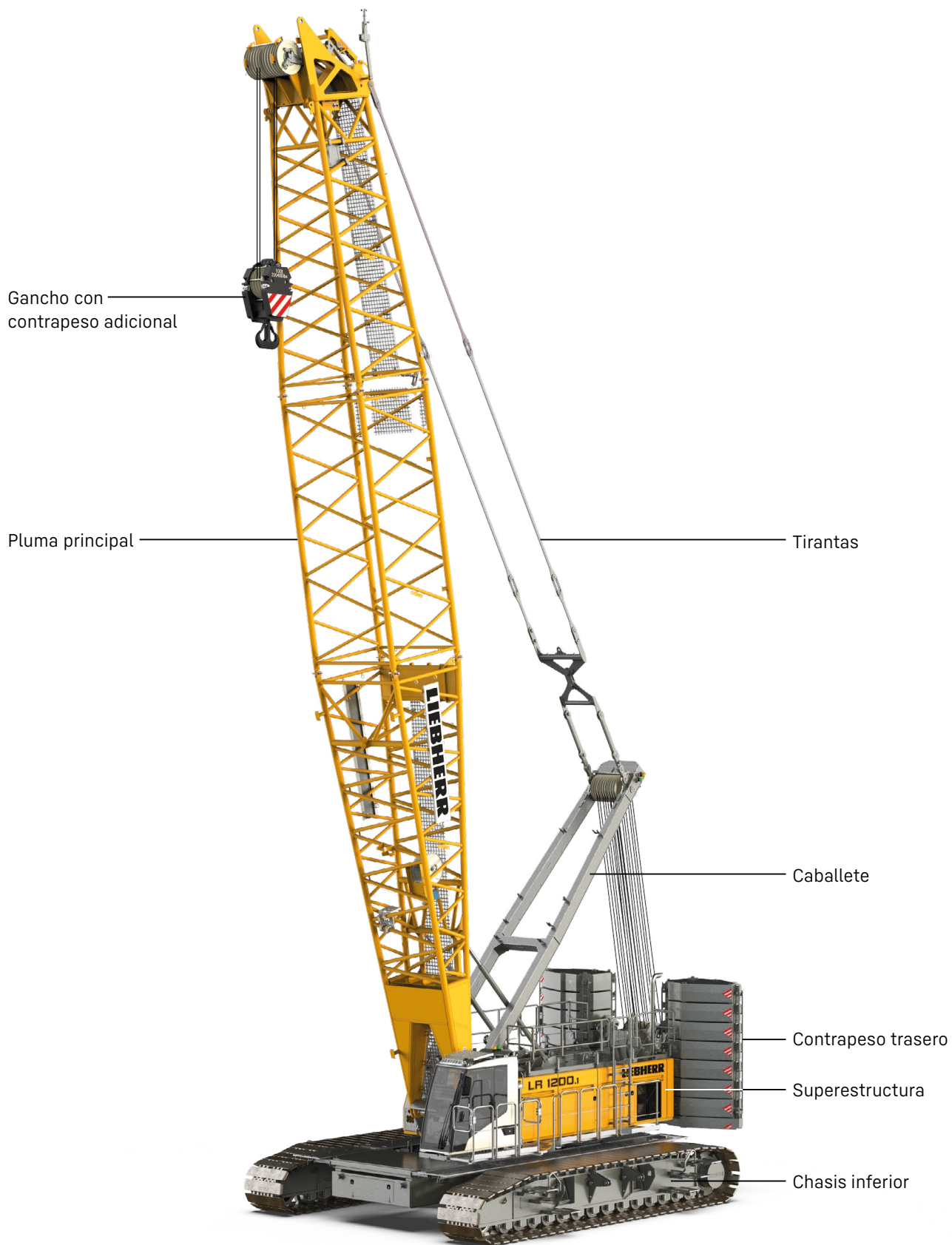

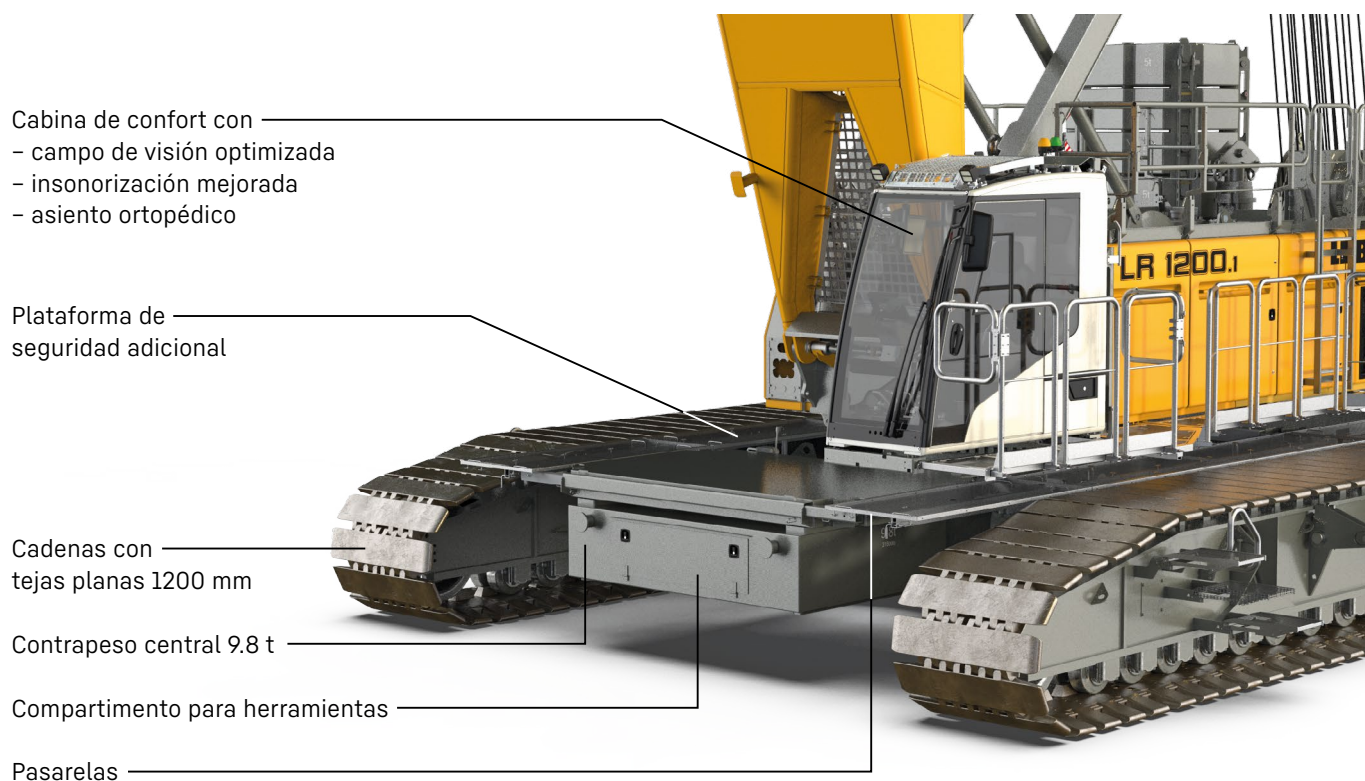

Cabina de confort con
 - campo de visión optimizada
 - insonorización mejorada
 - asiento ortopédico

Plataforma de
 seguridad adicional

Cadenas con
 tejas planas 1200 mm

Contrapeso central 9.8 t

Compartimento para herramientas

Pasarelas

Gran potencia

Los potentes, eficientes y fiables motores diésel de última generación permiten un elevado rendimiento y la ejecución simultánea de varios movimientos.

Presión sobre el suelo

La presión de suelo actual se calcula acorde a la configuración y posición de la máquina en la cabina del operador. Usando la opción del software Crane Planner de Liebherr ya se puede calcular y visualizar la presión real del suelo en la fase de preparación.

Cabina con el máximo confort

La visibilidad optimizada se une a un especial confort proporcionado, por ejemplo, por el asiento ortopédico con función de calefacción y refrigeración y las palancas de control sensibles y ergonómicas.

Sistema de control

Manejo sencillo e intuitivo de las funciones de control y mantenimiento de la máquina en un monitor en color de gran tamaño que presenta la información de forma clara. Diseñado para condiciones ambientales extremas.

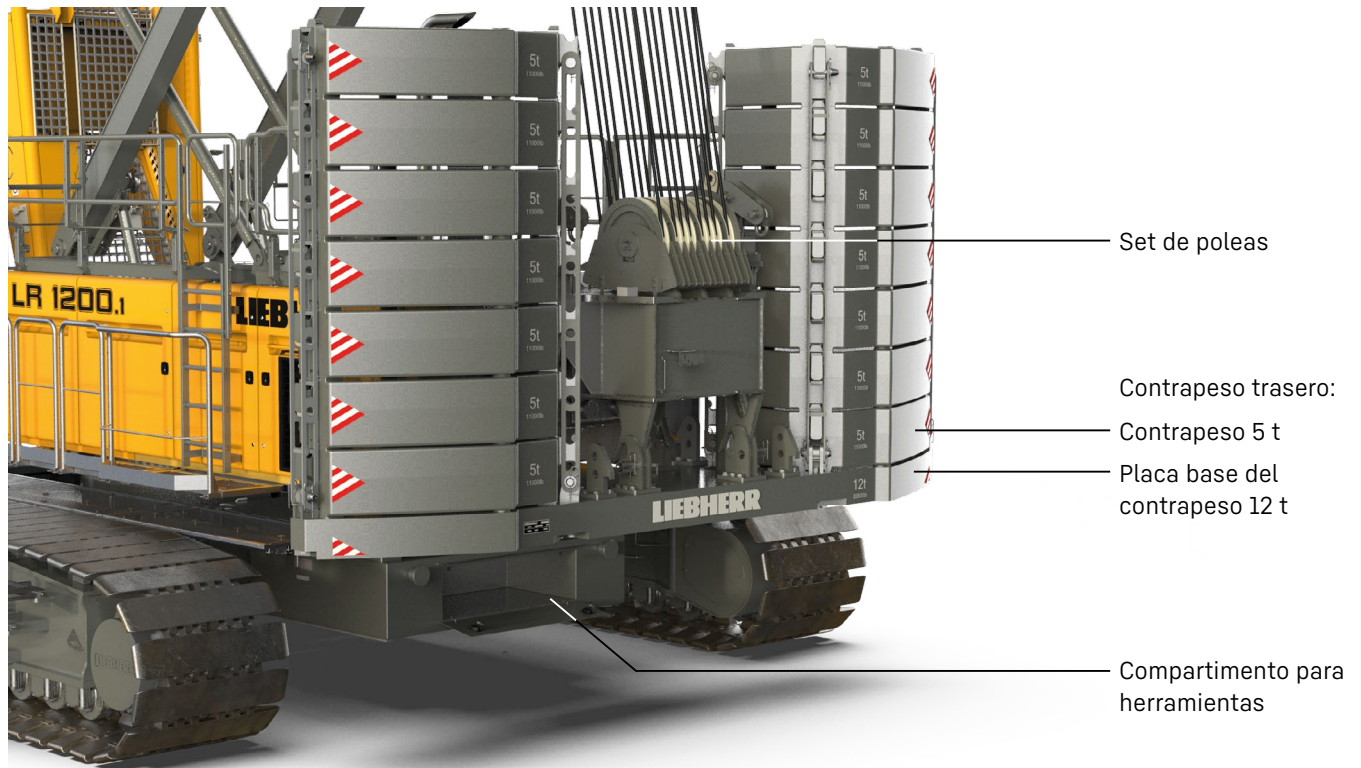

Sistema de auto-montaje eficiente y tiempos de montaje reducidos

El sistema de auto-montaje permite montar y desmontar las cadenas de forma segura, independiente y rápida, así como los contrapesos central y trasero y los elementos de la pluma.

Movilidad

Movilidad máxima gracias a la optimización de las piezas de la grúa para el transporte. El ancho máximo de transporte es de 3 m.

Mantenimiento sencillo

El diseño facilita tanto su mantenimiento como acceso seguro a los componentes.

Pluma/plumín

La variedad de sistemas de pluma y configuraciones permite optimizar su uso en las obras más diversas.

Descripción técnica



Motor diésel

Potencia controlada de acuerdo a la norma ISO 9249	230 kW (313 cv) a 1700 r.p.m.
Modelo	Liebherr D 944 A7-05
Capacidad de tanque	790 l capacidad con indicador continuo de nivel y de reserva
Certificación de escapes	97/68 CE Stage IV; EPA/CARB Tier 4f 97/68 CE Stage IV; EPA/CARB Tier 4f ECE-R.96 Power Band H normativa de emisiones no certificada



Emisión de sonidos y vibración

Emisiones de sonidos	corresponden con la normativa 2000/14/CE	
Nivel de presión acústica de emisión L_{PA}	74.0 dB(A)	(en la cabina)
Nivel de potencia de sonido L_{WA} garantizado	105 dB(A)	(de la máquina)
Vibración transmitida al operador	< 2.5 m/s ²	(al tronco superior)
	< 0.5 m/s ²	(a todo el cuerpo)



Sistema hidráulico

Bombas hidráulicas	una bomba doble de desplazamiento axial mantiene el sistema hidráulico de circuito abierto, permitiendo realizar todas las funciones de forma simultánea se incorpora una válvula de corte en la bomba para evitar picos de presión hidráulica
Tanque de hidráulico	650 l
Presión máx.	350 bar
Aceite hidráulico	todos los filtros están controlados electrónicamente existe la posibilidad de utilizar aceites sintéticos ecológicos



Sistema de control

Sistema de control	incluye todas las funciones de control y monitorización, diseñado para superar condiciones ambientales más adversas y para trabajar en tareas de extrema dureza
Visualización	pantalla de alta resolución en la cabina del operador, todos los datos relevantes de la operativa de la máquina, así como los mensajes de error y avisos, se visualizan en el idioma requerido
Operación	se pueden realizar varios movimientos simultáneamente gracias al control proporcional electro-hidráulico, todas las categorías de cargas se pueden posicionar con la máxima precisión



Mecanismo de traslación

Accionamiento	con motores hidráulicos de pistones axiales
Cadenas	libre de mantenimiento, tensor de cadenas hidráulico
Freno	freno de discos múltiples con accionamiento hidráulico y con resorte
Velocidad de traslación	0-1.6 km/h
Tejas planas	ancho 1200 mm



Mecanismo de giro

Accionamiento	con motores hidráulicos de pistones axiales, engranaje planetario y piñón
Corona giratoria	corona de giro de rodamientos con dientes exteriores
Freno	freno de discos múltiples con accionamiento hidráulico y con resorte
Velocidad de giro	0-3 r.p.m., regulable sin escalonamientos
Preselección de velocidad	el giro se puede accionar preseleccionando una velocidad o mediante el giro libre cuando se selecciona una velocidad: el freno de disco (freno de parada) se cierra, si no se efectúa ningún movimiento de giro



Cabrestantes

Cabrestantes de grúa 1 y 2 estándares	consisten de un engranaje planetario interno, bañado en aceite y de mantenimiento mínimo. Para los cabrestantes se utilizan motores de control de alta presión y caudal variable. Este sistema dispone de sensores que automáticamente ajustan el caudal de aceite para alcanzar la máxima velocidad dependiendo de la carga suspendida
Tiro (7a capa)	120 kN
Diámetro cables	26 mm
Diámetro del tambor	580 mm
Velocidad del cable	0-136 m/min
Longitud de cable en 7 capas	489 m
Opción - cabrestante con caída libre	Caída libre: la función de freno y de embrague se realiza solo con el freno de trabajo (freno de discos múltiples de diseño compacto, de bajo desgaste y sin necesidad de mantenimiento)







Cabrestantes de pluma/plumín

Pluma principal	
Tiro	máx. 180 kN
Diámetro cables	24 mm
Velocidad	15-86° en 130 s
Plumín	
Tiro	máx. 105 kN
Diámetro cables	20 mm
Velocidad	15-78° en 51 s

Peso operacional

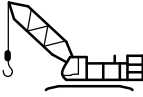
Composición del peso operacional	Máquina base con cadenas Cabrestantes 1 + 2, caballete pluma principal de 20 m, que se compone de un pie de pluma (10 m), cabeza de pluma (7 m) y tramo de pluma (3 m) contrapeso trasero 82.3 t (14 × 5 t + 1 × 12 t + 0.3 t) contrapeso central 36 t (2 × 9.8 t + 2 × 8.3 t) gancho 250 t
Peso total	aprox. 210 t

Modos de aplicación

	 Elevación	 Cuchara	 Elevación de personas
 Tierra	✓	✓	✓
 Estructura flotante (barcaza)	✓	✓	✓ *

* sólo para barcazas elevadoras

Equipo opcional

Máquina base

Cabrestantes principales 12 t con caída libre
Pintura según petición cliente
Ganchos 12.5 / 40 / 80 / 100 / 160 / 250 t

Economía y ecología

Kit Eco-Silent
Unidad de potencia auxiliar (APU 2.8 kW)

Pluma/plumín

Plumín abatible: Cabrestantes de pluma/plumín
Tirantes en fibra de carbono CFK

Accesorios para pluma

Pasarela para pie de pluma, protección anticaída incluido
Pasarela para cabeza de pluma, protección anticaída incluido
Guía de cable para pasarela de pluma principal, protección anticaída incluido
Arnés adicional para protección anticaída para 1 persona
Pasarela para tramos de pluma 3 / 6 / 12 m
Pasarela para tramos de pluma 3 / 6 / 12 m, protección anticaída incluida

Paquetes de aplicaciones

Modo de aplicación: elevación de personas (O)
Modo de aplicación: barcaza (O)
Modo de aplicación: cimentaciones especiales (O)
Modo de aplicación: preselección velocidad del viento
Modo de aplicación: preselección marcha con carga (S)

Sincronización de cabrestantes
Radio control remoto
Enrollamiento de cable por control remoto
Radio control remoto para montaje
Usar el cabrestante de plumín abatible como cabrestante auxiliar
Elemento antigiro 2 t caída libre
Cabrestante principal tensión constante
Operación con 2 ganchos
Dispositivo para elevación de cabina hidráulico (6 m)

Funciones adicionales

Crane Planner 2.0
LiDAT

Auto-montaje

Sistema de auto-descarga estándar / telescópica
Sistema de auto-montaje contrapeso
Sistema de auto-montaje
Cabrestante auxiliar reenvíos
Ancho de vías, accionamiento hidráulico

Paquete de servicios

Bomba de repostaje Diesel / AdBlue
Kit para frío -25 °C / -40 °C
Filtro de aceite hidráulico de bypass
Engrase automático de corona de giro - rodamientos
Aceite hidráulico Plus (longlife & bio)
Aceite hidráulico Plus bajas temperaturas (longlife & bio)
Aceite hidráulico Plus bajas temperaturas (longlife)

Seguridad adicional

Sistema de asistencia: Boom Up-and-Down Assistant
Sistema de asistencia: Estabilizador de carga horizontal (Horizontal Load Path)
Sistema de asistencia: Vertical Line Finder
Sistema de asistencia: Indicación y visualización de la presión sobre el suelo
Cámara adicional trasera y lateral
Cámara cabrestante
Cámara con zoom cabeza de pluma
Pasarelas y barandillas en superestructura, ancho 570 mm
Escalera adicional para el montaje de la pluma
Barandillas plegables para la superestructura
Barandillas para pasarela de la cabina
Protección del techo de la cabina FOPSI
Protección cabina anti-vandalismo
Indicador de altura de trabajo para los dos cabrestantes de elevación
Grupo de emergencia diesel-hidráulico 18.4 kW, Plug&Play
Dispositivo limitador de radio de pluma y giro
Piloto de aviso aéreo
Indicador luminoso de aviso de giro
Pararrayos
Indicador mecánico de ángulo
Válvula de cierre de entrada de aire
Control de acceso

Comodidad para el operario

Escalera adicional
Luces adicionales
Aire acondicionado cabina
Dispositivo hidráulico para inclinación de cabina
Avisador de nivel del aceite para engranajes
Idioma adicional monitor

(S) estándar, (O) opción

Dimensiones

Máquina base con chasis inferior

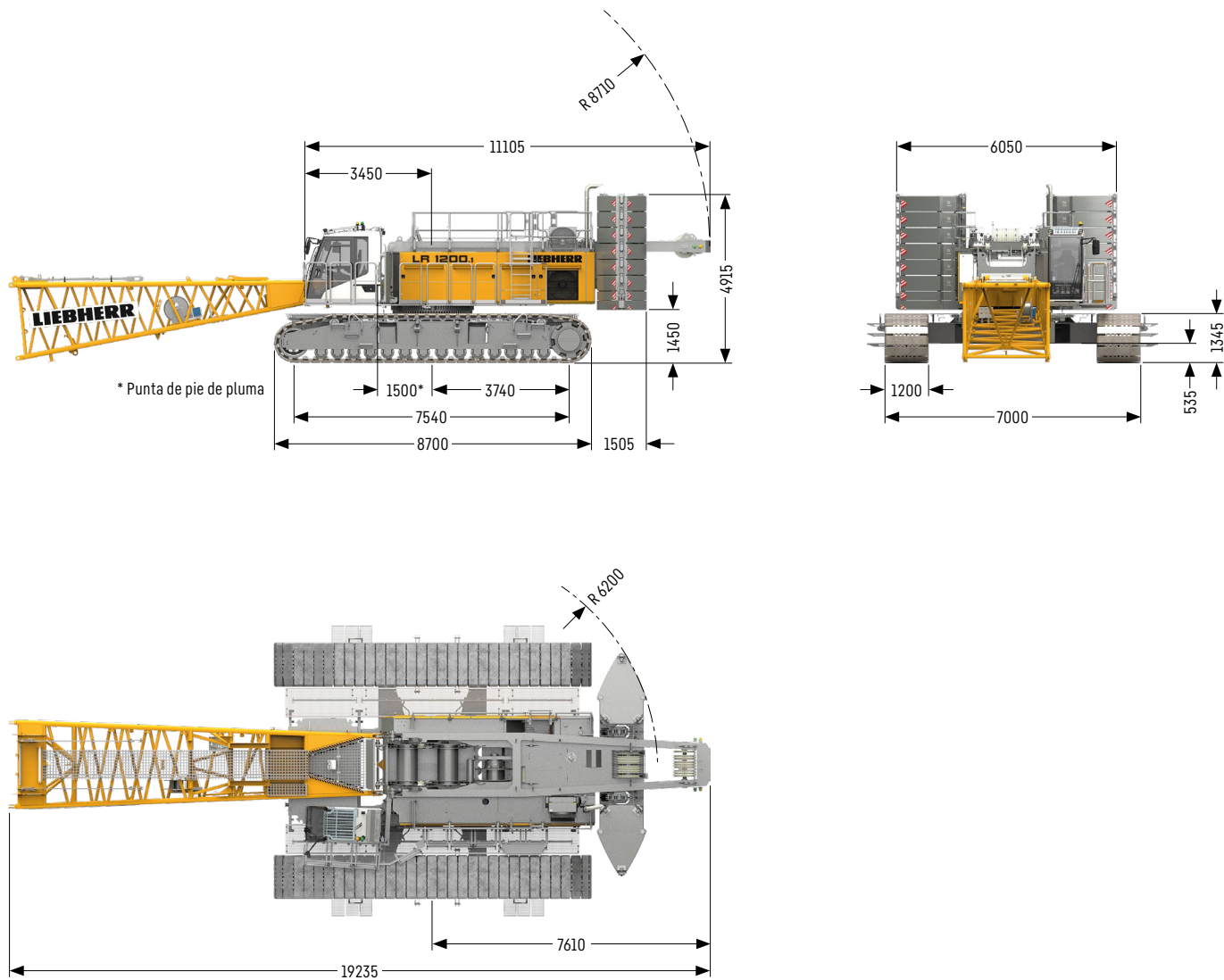

Dimensiones y pesos de transporte

Máquina base y pluma principal 2320.xx

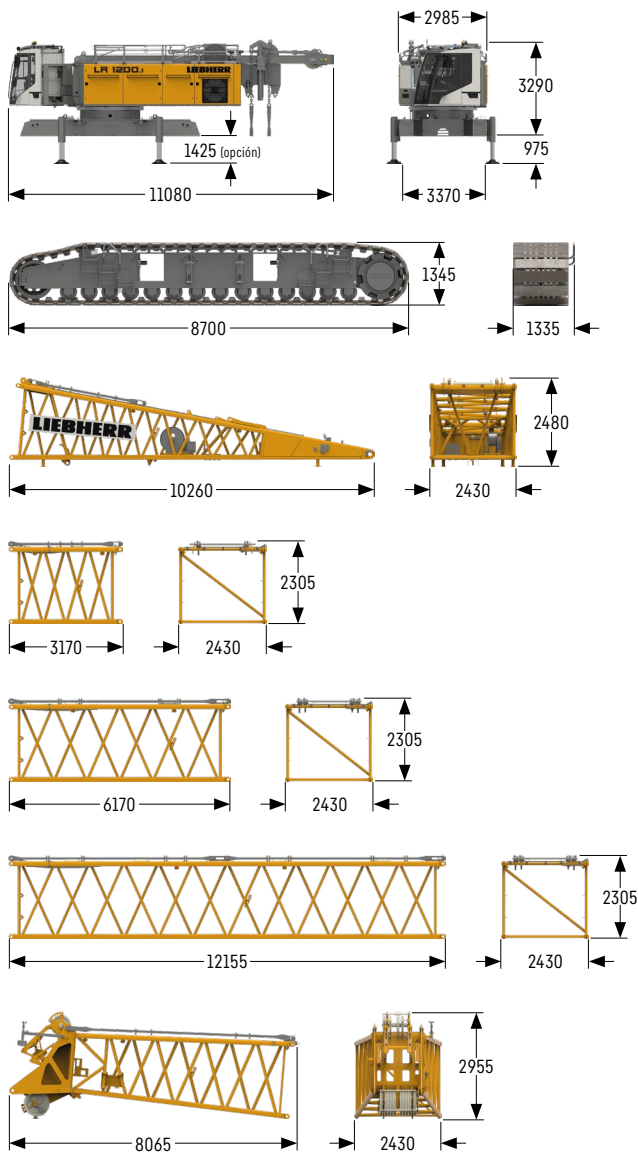

Máquina base

Peso sin cables de carga	kg	37228
Peso de los cables de carga	kg/m	3.4

con caballete 1, cabrestantes 1 + 2 (2x 120 kN), sin pie de pluma, sin contrapeso trasero, sin contrapeso central y cadenas

Cadenas

Peso de las tejas planas 1200 mm	kg	19658
----------------------------------	----	-------

Pie de pluma 10 m (No. 2320.25)

Peso con cabrestante	kg	4827
Peso sin cabrestante	kg	3737

Tramo de pluma 3 m (No. 2320.23)

Peso con tirantes de pluma	kg	871
Peso con HPT ¹⁾ y NDL ²⁾	kg	959

Tramo de pluma 6 m (No. 2320.20)

Peso con tirantes de pluma	kg	1180
Peso con HPT ¹⁾ y NDL ²⁾	kg	1333

Tramo de pluma 12 m (No. 2320.20)

Peso con tirantes de pluma	kg	2109
Peso con HPT ¹⁾ y NDL ²⁾	kg	2412

Cabeza de pluma 7 m (No. 2320.23)

Peso con tirantes de pluma	kg	3613
----------------------------	----	------

¹⁾ HPT: Tirantes de pluma

²⁾ NDL: Tirantes de plumin

Opción de transporte 2320.xx / 1916.xx

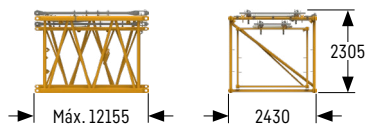

Opción de transporte (No. 2320.xx / 1916.xx)

No. 2320.xx / 1916.xx	m	3 / 3	6 / 6	12 / 12
Peso incluido tirantes	kg	1453	2064	3699

Plumín fijo 1008.xx

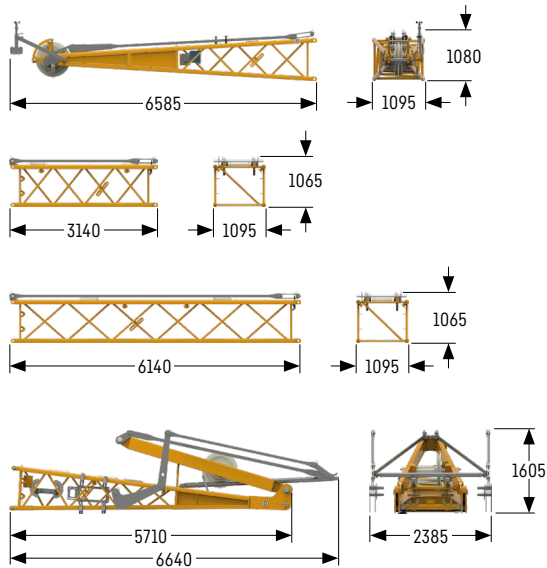

Cabeza de pluma 5.5 m (No. 1008.20)

Peso incluido tirantas	kg 873
------------------------	--------

Tramo de plumín fijo 3 m (No. 1008.17)

Peso incluido tirantas	kg 267
------------------------	--------

Tramo de plumín fijo 6 m (No. 1008.17)

Peso incluido tirantas	kg 448
------------------------	--------

Pie de plumín fijo 5.5 m con caballete (No. 1008.20)

Peso incluido tirantas	kg 2110
------------------------	---------

Plumín fijo 0806.xx

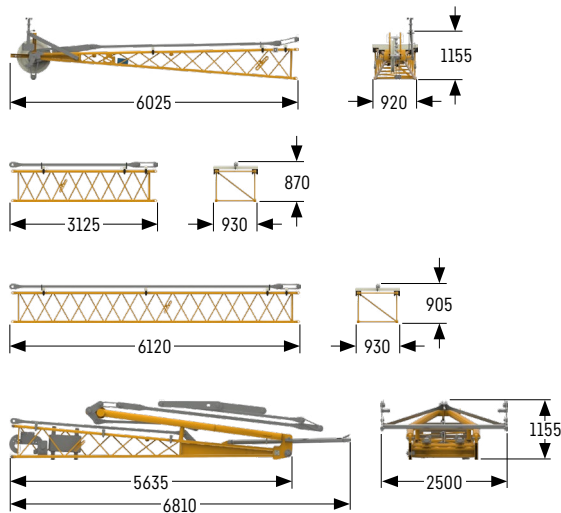

Cabeza de pluma 5.5 m (No. 0806.16)

Peso incluido tirantas	kg 442
------------------------	--------

Tramo de plumín fijo 3 m (No. 0806.15)

Peso incluido tirantas	kg 141
------------------------	--------

Tramo de plumín fijo 6 m (No. 0806.15)

Peso incluido tirantas	kg 249
------------------------	--------

Pie de plumín fijo 5.5 m con caballete (No. 0806.16)

Peso incluido tirantas	kg 1017
------------------------	---------

Plumín fijo 0906.21

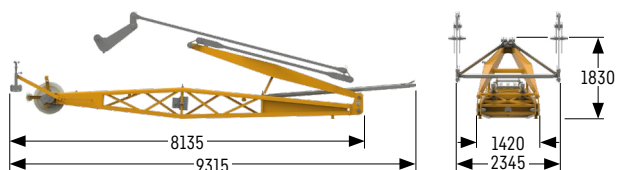

Plumín fijo 7 m (No. 0906.21)

Peso incluido tirantas	kg 2413
------------------------	---------

Plumín abatible 1713.xx

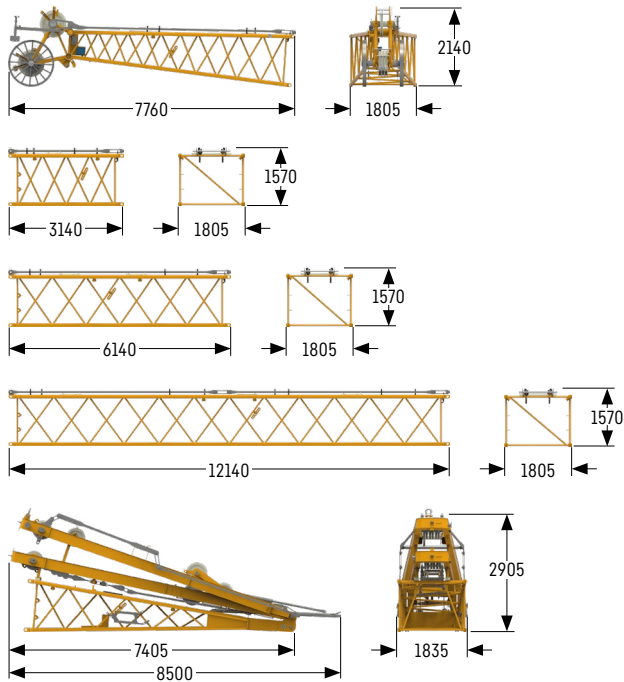

Cabeza de plumín abatible 7 m (No. 1713.21)

Peso incluido tirantas	kg 1376
------------------------	---------

Tramo de plumín abatible 3 m (No. 1713.18)

Peso incluido tirantas	kg 394
------------------------	--------

Tramo de plumín abatible 6 m (No. 1713.18)

Peso incluido tirantas	kg 624
------------------------	--------

Tramo de plumín abatible 12 m (No. 1713.18)

Peso incluido tirantas	kg 1122
------------------------	---------

Pie de plumín abatible 7 m con caballetes 2 + 3 (No. 1713.22)

Peso incluido tirantas	kg 4763
------------------------	---------

Plumín abatible 1916.xx

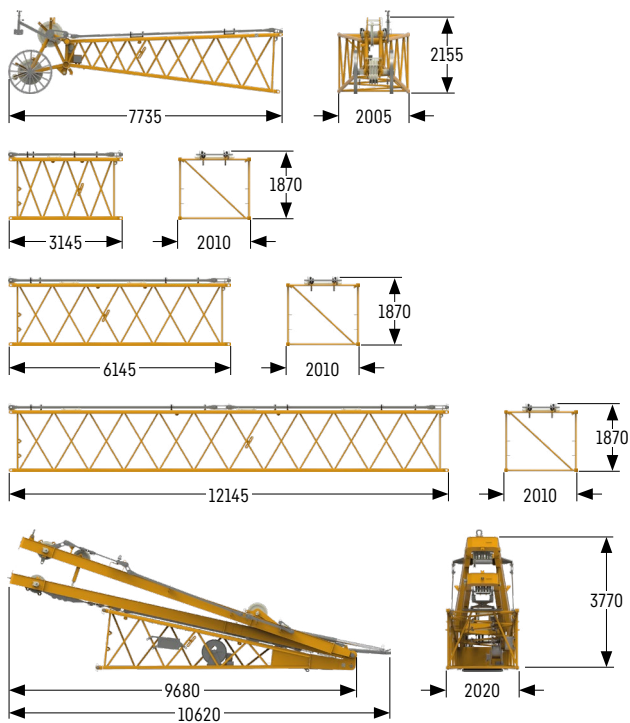

Cabeza de plumín abatible 7 m (No. 1916.21)

Peso incluido tirantas	kg 1520
------------------------	---------

Tramo de plumín abatible 3 m (No. 1916.18)

Peso incluido tirantas	kg 494
------------------------	--------

Tramo de plumín abatible 6 m (No. 1916.18)

Peso incluido tirantas	kg 731
------------------------	--------

Tramo de plumín abatible 12 m (No. 1916.18)

Peso incluido tirantas	kg 1287
------------------------	---------

Pie de plumín abatible 7 m con caballetes 2 + 3 (No. 1916.22)

Peso incluido tirantas	kg 6237
------------------------	---------

Contrapeso

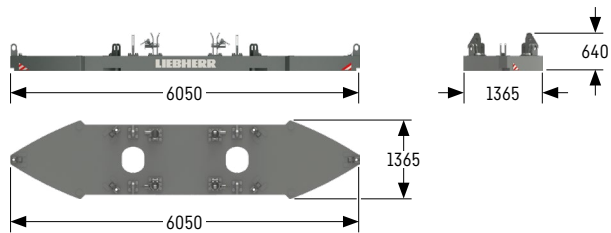

Placa base del contrapeso sin sujeciones (1x)

Peso	kg 12000
------	----------

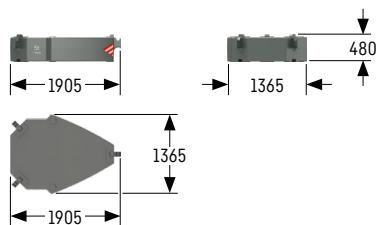

Contrapeso (14x)

Peso	kg 5000
------	---------

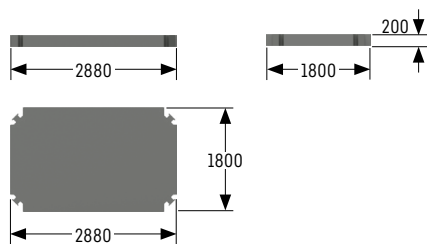

Contrapeso central (2x)

Peso	kg 8300
------	---------

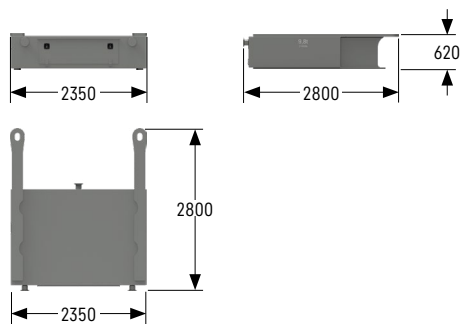

Contrapeso central (2x)

Peso	kg 9800
------	---------

Ganchos con peso adicional / ganchos simples

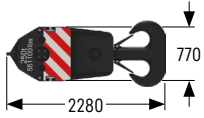

Gancho 250 t - 11 poleas

Ancho	mm	1250
Peso	kg	2300 / 3200

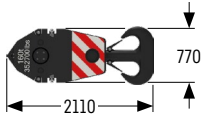

Gancho 160 t - 7 poleas

Ancho	mm	885
Peso	kg	1500 / 2250 / 3000

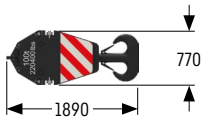

Gancho 100 t - 5 poleas

Ancho	mm	745
Peso	kg	1300 / 1800 / 2300

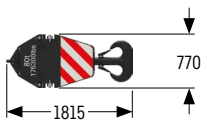

Gancho 80 t - 3 poleas

Ancho	mm	565
Peso	kg	1000 / 1500 / 2000

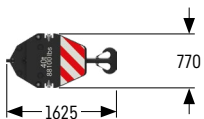

Gancho 40 t - 1 polea

Ancho	mm	490
Peso	kg	700 / 1100 / 1500

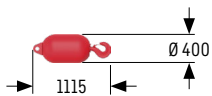

Gancho 12.5 t

Peso	kg	600
------	----	-----

Sistema de auto-montaje

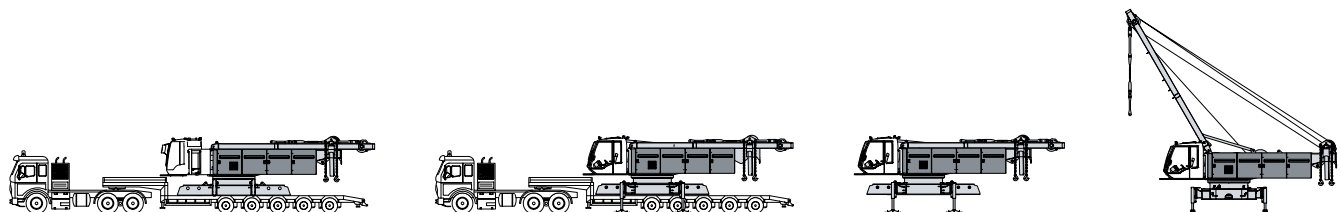

Descarga de la máquina base

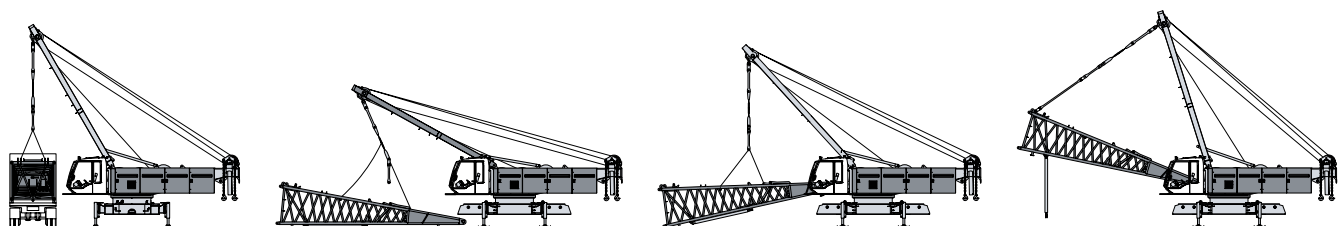

Descarga y montaje del pie de pluma

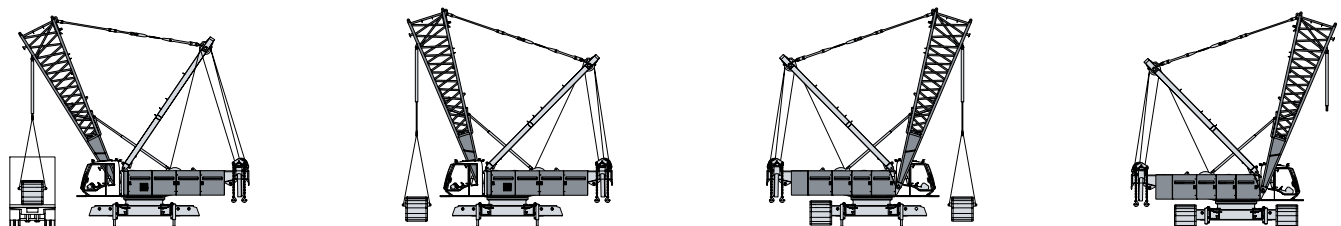

Descarga y montaje de las cadenas

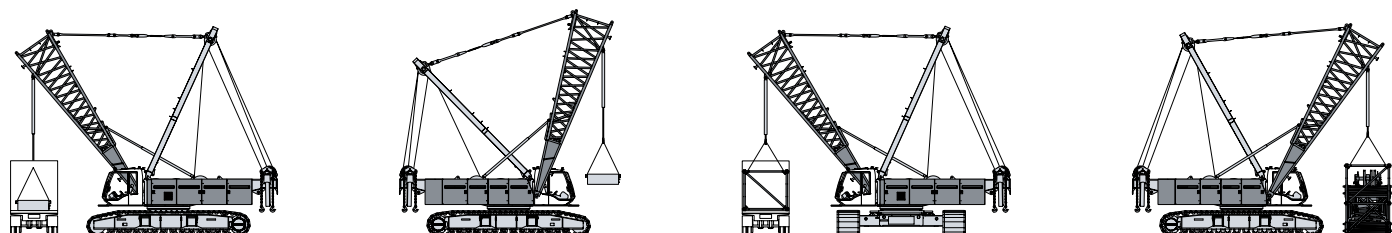

Descarga y montaje del contrapeso central

Descarga y montaje de la pluma

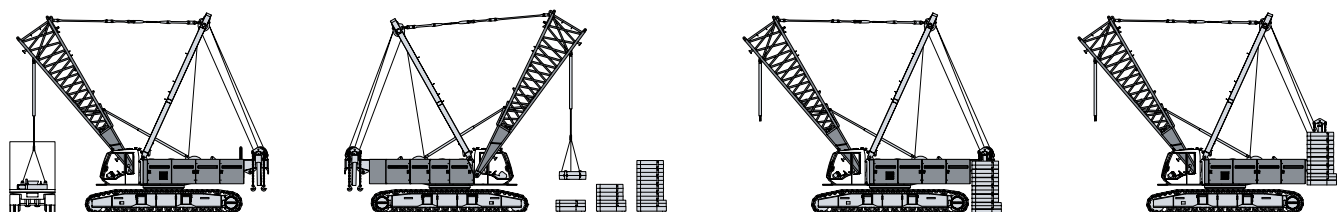

Descarga y montaje del contrapeso

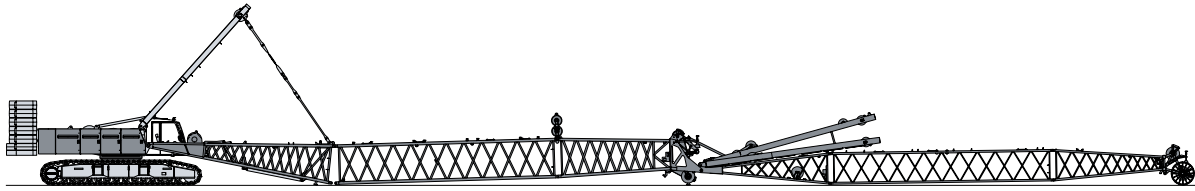

Montaje de la pluma

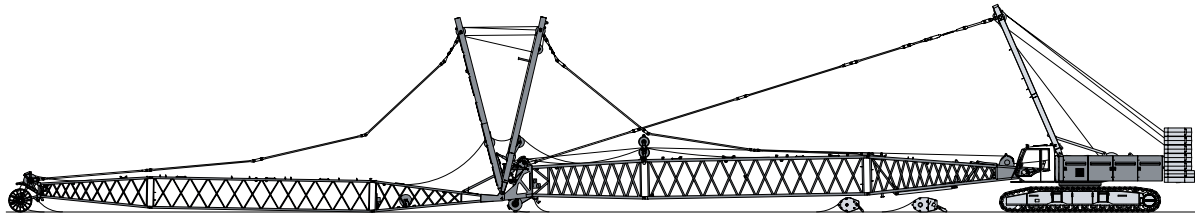

Montaje de los cables de elevación de la pluma principal y del plumín abatible

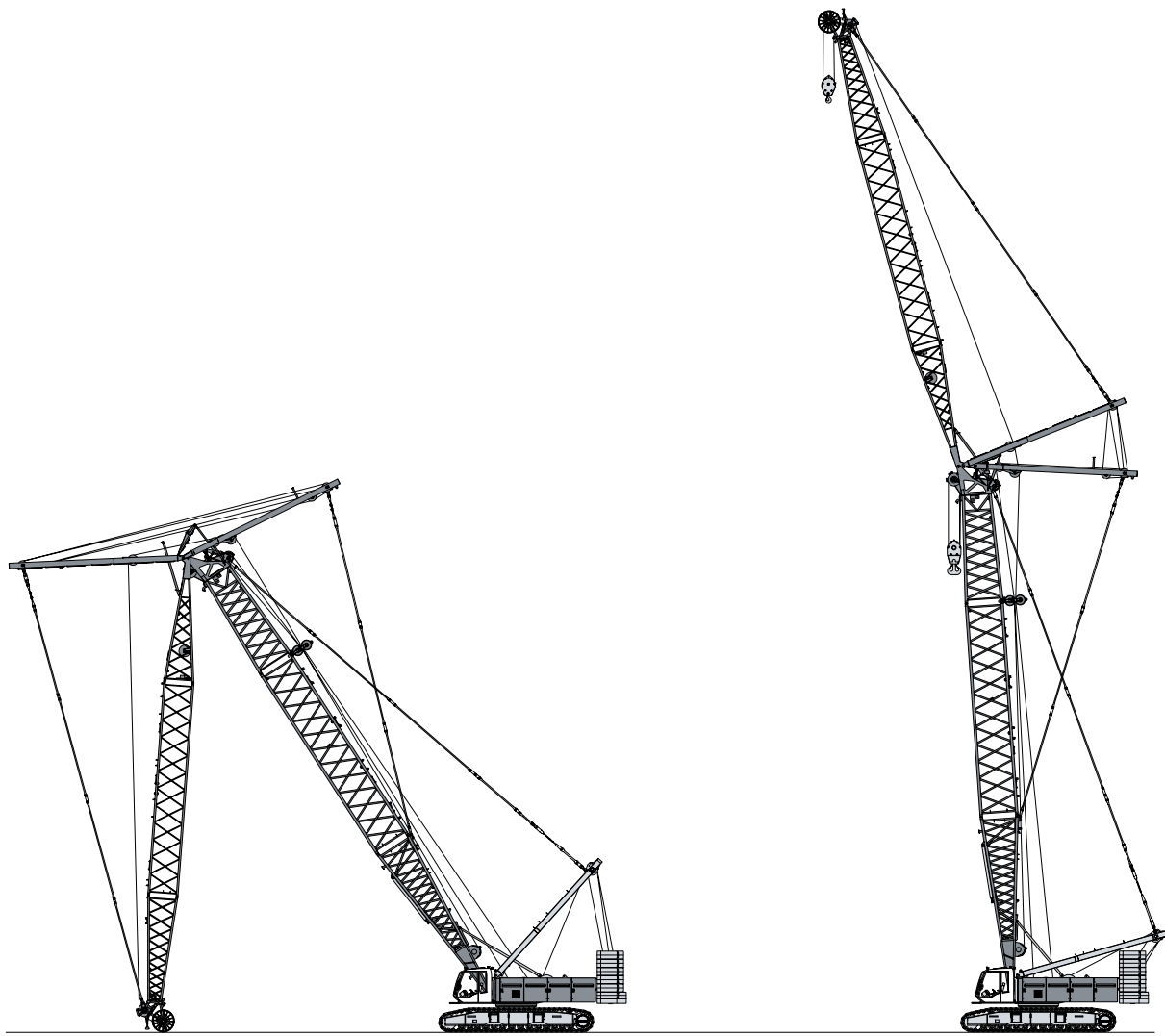

Elevación de la pluma principal y del plumín abatible

Configuraciones de pluma

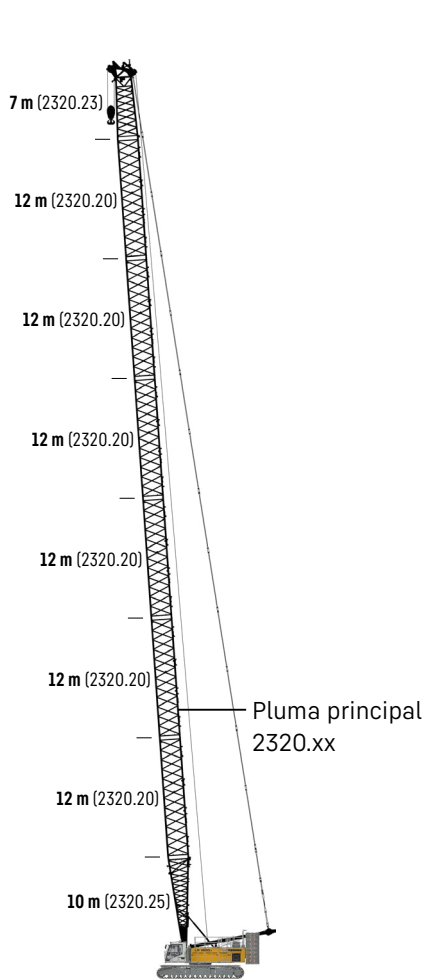

Pluma principal

Modo 1

Longitud máx.

2320.xx m 89

Más información en la página 18.

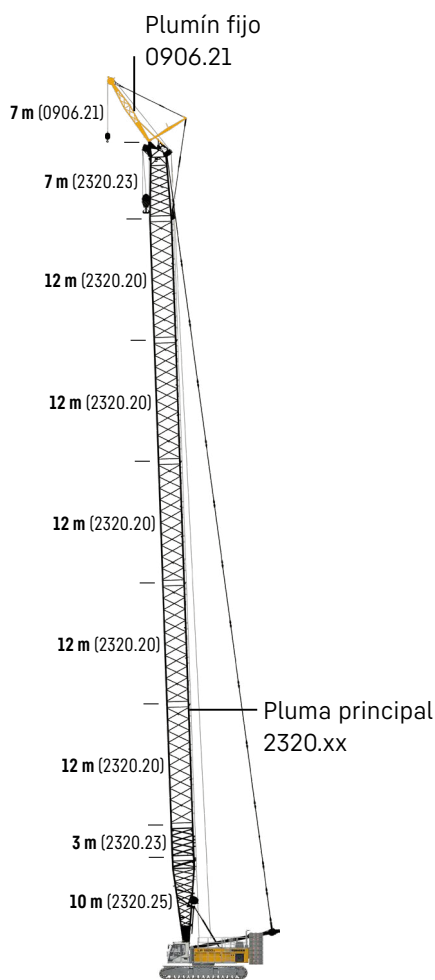

Pluma principal + plumín fijo

Modo 3

Combinación máx.

2320.xx m 80

0906.21 m 7

Longitud total m 87

Más información en la página 38.

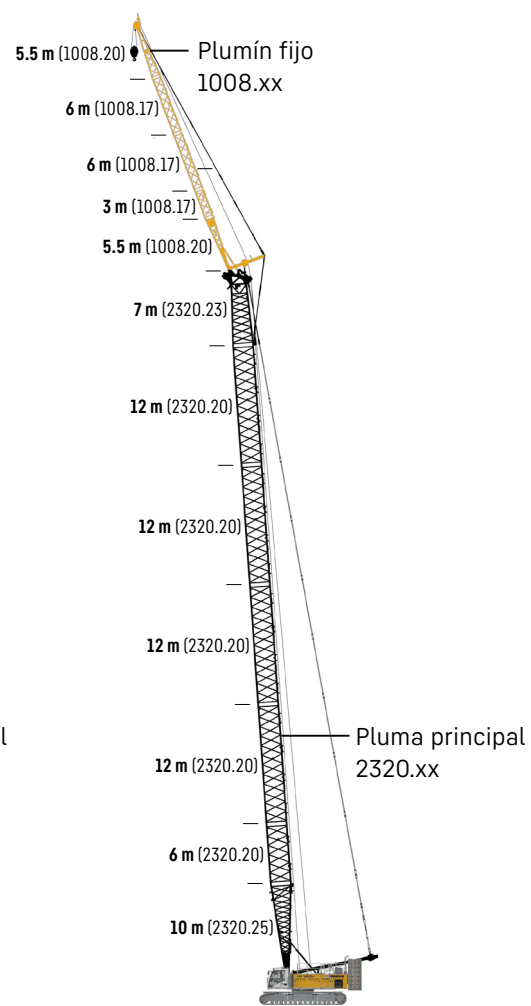

Pluma principal + plumín fijo

Modo 3

Combinaciones máx.

2320.xx m 71 74 77

1008.xx m 26 23 17

Longitud total m 97 97 94

Más información en la página 32.

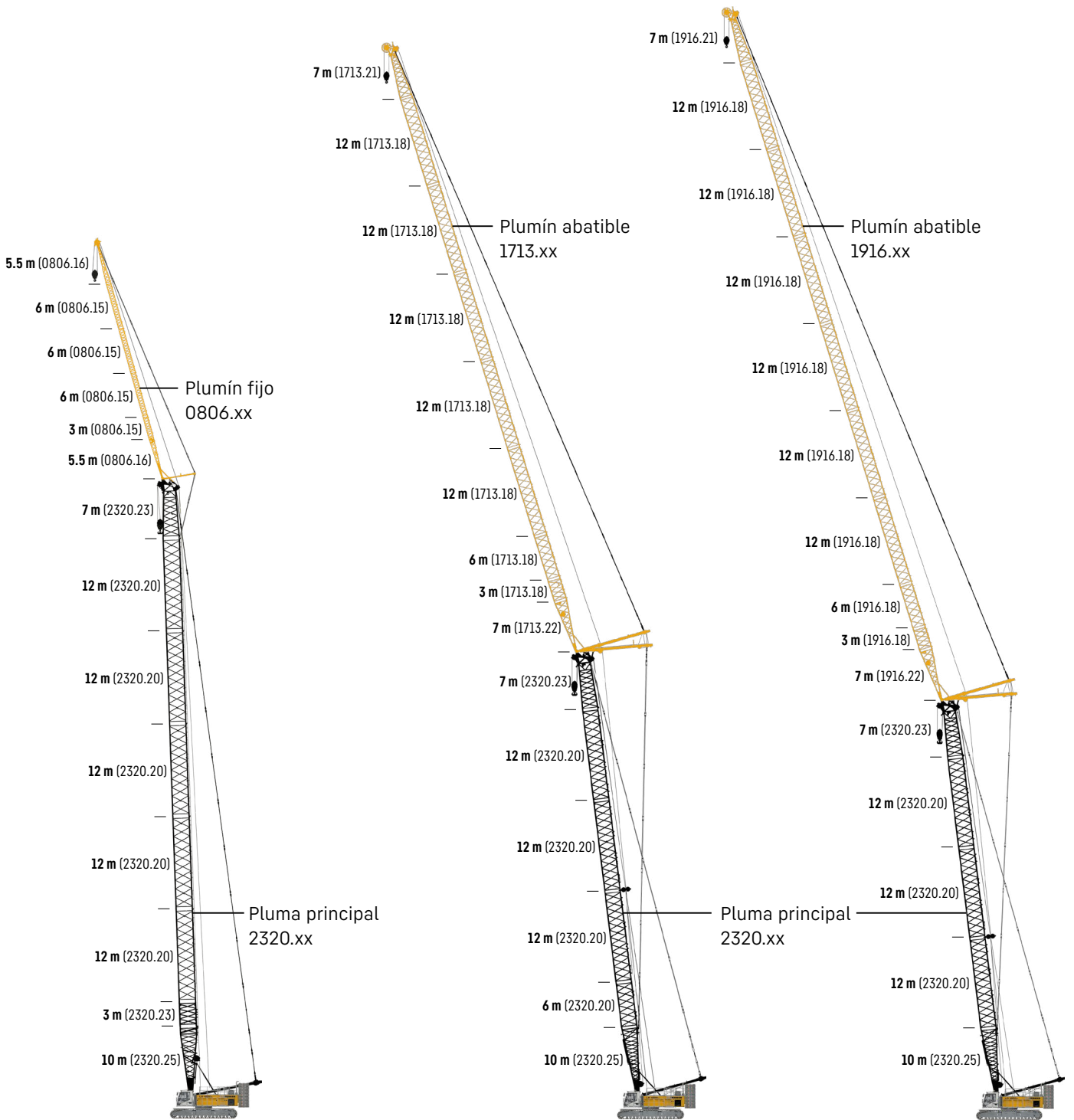

Pluma principal + plumín fijo

Modo 3

Combinaciones máx.

2320.xx	m	80	83
0806.xx	m	32	23
Longitud total	m	112	106

Más información en la página 35.

Pluma principal + plumín abatible

Modo 4

Combinaciones máx.

2320.xx	m	59	62	65
1713.xx	m	83	74	53
Longitud total	m	142	136	118

Más información en la página 20.

Pluma principal + plumín abatible

Modo 4

Combinaciones máx.

2320.xx	m	53	56	59
1916.xx	m	95	80	62
Longitud total	m	148	136	121

Más información en la página 26.

Pluma principal 2320.xx

Longitud de plumín 20-89 m

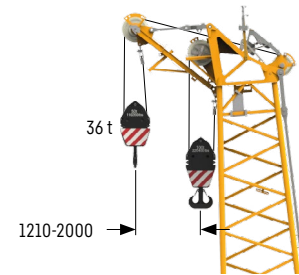
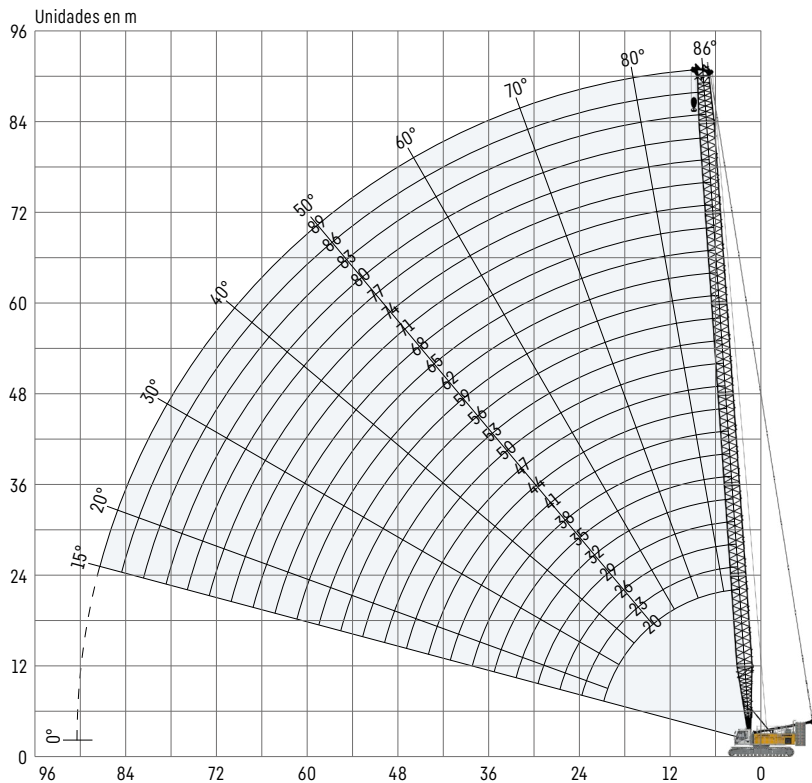

Plumín auxiliar fijo 36 t (opción)

La carga máx. del plumín auxiliar es de 36 t. Este plumín tiene su propia tabla de carga y requiere su correcta selección en el programa del limitador de carga en la cabina.

Configuración de pluma principal 2320.xx

Tramos de pluma	Número de tramos de pluma											
	1	2	3	4	5	6	7	8	9	10	11	12
Pie de pluma 10 m	1	1	1	1	1	1	1	1	1	1	1	1
Tramo de pluma 3 m	1		1		1		1		1		1	
Tramo de pluma 6 m		1	1			1	1			1	1	
Tramo de pluma 12 m				1	1	1	1	2	2	2	2	3
Cabeza de pluma 7 m	1	1	1	1	1	1	1	1	1	1	1	1
Longitud de pluma [m]	20	23	26	29	32	35	38	41	44	47	50	53
Plumín auxiliar fijo	✓	✓	✓	✓	✓	✓	✓	✓	✓	✓	✓	✓
Pie de pluma 10 m	1	1	1	1	1	1	1	1	1	1	1	1
Tramo de pluma 3 m	1		1		1		1		1		1	
Tramo de pluma 6 m		1	1			1	1			1	1	
Tramo de pluma 12 m	3	3	3	4	4	4	4	5	5	5	5	6
Cabeza de pluma 7 m	1	1	1	1	1	1	1	1	1	1	1	1
Longitud de pluma [m]	56	59	62	65	68	71	74	77	80	83	86	89
Plumín auxiliar fijo	✓	✓	✓	✓	✓	✓	✓	✓	✓	✓	✓	✓

Capacidades con pluma principal

Tabla de carga [t] con contrapeso trasero 82.3 t y contrapeso central 36 t

Radio [m]	Longitud de pluma [m]											
	20	26	32	38	44	50	56	62	68	74	80	89
6					114.8							
7				129.5	107.8	90.1	80.2	65.4				
8		141.2	132.6	118.8	100.9	83.7	77.6	64.9	52.0	45.0		
9	129.7	122.8	116.0	109.8	93.2	78.8	74.8	62.1	50.3	44.7	37.0	26.6
10	114.2	108.5	103.0	98.0	87.2	73.6	71.9	60.2	48.3	43.1	36.0	26.6
14	70.5	70.5	70.5	67.7	65.2	59.2	60.4	52.3	41.4	38.1	31.7	24.0
20	43.3	43.5	43.5	43.2	43.0	42.4	41.0	39.5	33.7	32.6	27.0	20.4
22		38.3	38.3	38.0	37.8	37.5	36.7	35.5	32.0	31.1	25.6	19.4
24		34.0	34.0	33.8	33.6	33.3	33.0	32.0	30.2	29.8	24.5	18.5
26		30.4	30.5	30.3	30.1	29.8	29.5	29.1	28.1	27.1	23.5	17.7
32			22.8	22.7	22.5	22.1	21.9	21.5	21.2	20.7	19.9	16.1
38				17.5	17.4	17.1	16.8	16.5	16.2	15.8	15.4	14.3
44					13.8	13.5	13.3	12.9	12.6	12.2	11.9	11.1
46						12.5	12.3	12.0	11.7	11.3	10.9	10.3
48						11.7	11.5	11.1	10.8	10.4	10.1	9.4
50						10.9	10.6	10.3	10.0	9.6	9.2	8.7
55							8.8	8.5	8.2	7.8	7.5	6.9
60								7.0	6.7	6.4	6.0	5.5
65									5.5	5.1	4.8	4.3
70										4.1	3.7	3.2
75											2.8	2.3

Tabla de carga [t] con contrapeso trasero 72.3 t y contrapeso central 36 t

Radio [m]	Longitud de pluma [m]											
	20	26	32	38	44	50	56	62	68	74	80	89
4.1	219.1											
5	216.9	162.8	153.6									
6	194.3	159.0	150.7	140.3	114.8							
7	164.9	152.5	141.8	129.5	107.8	90.1	80.2	65.4				
8	138.9	129.8	121.8	114.5	100.9	83.7	77.6	64.9	52.0	45.0		
9	119.8	112.8	106.5	100.8	93.2	78.8	74.8	62.1	50.3	44.7	37.0	26.6
16	53.7	53.7	53.6	53.3	51.4	49.5	47.7	45.9	38.8	36.2	29.9	22.5
18	45.7	45.7	45.7	45.5	45.0	43.4	41.9	40.4	36.0	34.3	28.5	21.3
20	39.5	39.6	39.6	39.4	39.2	38.5	37.2	35.8	33.7	32.6	27.0	20.4
26		27.6	27.7	27.4	27.2	26.9	26.6	26.2	25.2	24.3	23.3	17.7
28			24.9	24.7	24.5	24.2	23.9	23.6	23.0	22.0	21.2	17.1
32			20.5	20.4	20.2	19.9	19.6	19.2	18.9	18.4	17.6	16.1
34				18.6	18.5	18.1	17.9	17.5	17.2	16.8	16.1	14.8
40					14.3	14.0	13.7	13.4	13.1	12.7	12.3	11.3
46						11.1	10.8	10.5	10.2	9.8	9.4	8.6
48						10.2	10.0	9.6	9.3	8.9	8.6	7.9
50						9.5	9.2	8.9	8.6	8.2	7.8	7.2
55							7.6	7.3	6.9	6.6	6.2	5.7
60								5.9	5.6	5.2	4.9	4.3
65									4.4	4.1	3.7	3.2
70										3.1	2.8	2.2



TLT 13147978. Estas tablas de cargas sirven únicamente como información. Para trabajos de elevación consultar las tablas de cargas de la cabina o el manual. De lo contrario, lo recomendamos que planifique su trabajo de elevación con Crane Planner 2.0.

www.liebherr.com/CranePlanner

Crane Planner 2.0

Plumín abatible 1713.xx

Longitud de plumín 20-83 m

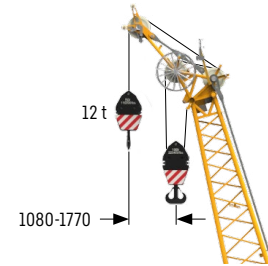
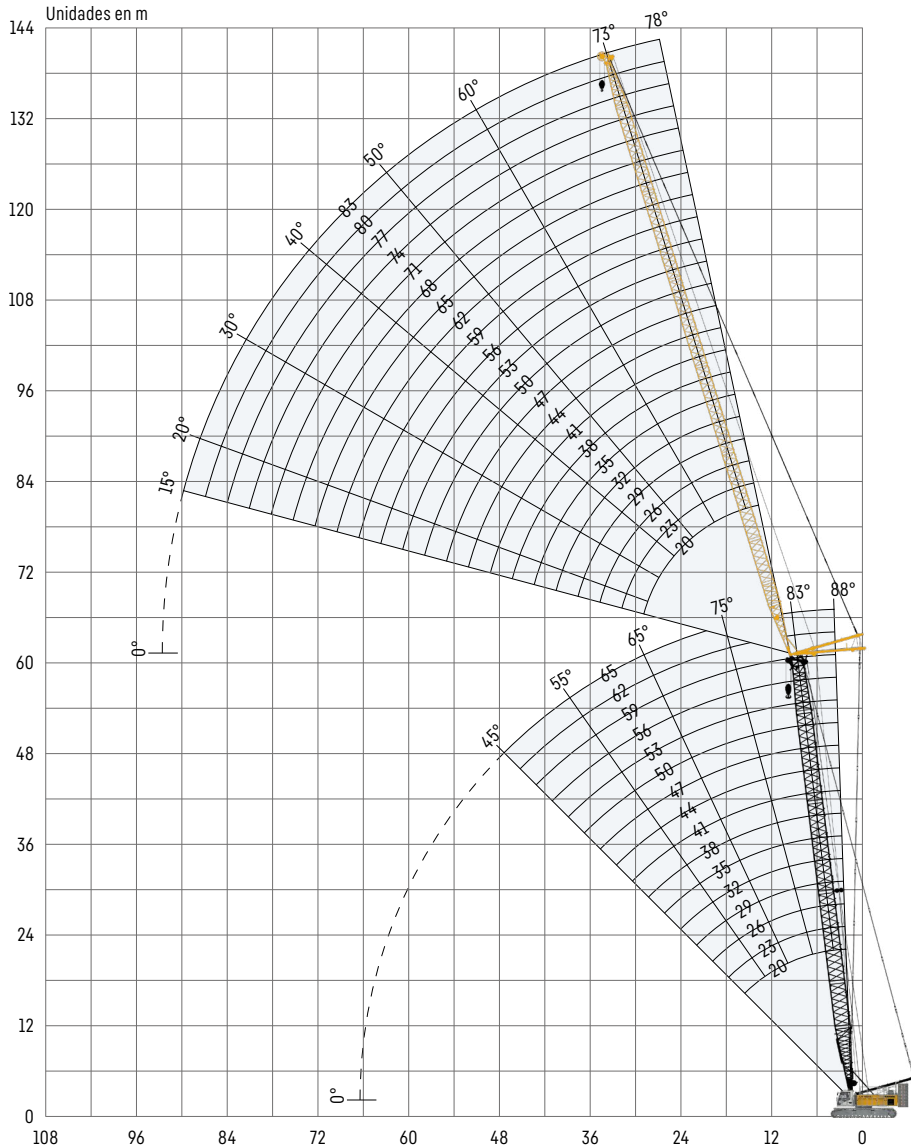

Plumín auxiliar fijo 12 t (opción)
La carga máx. del plumín auxiliar es de 12 t.

Configuración de plumín abatible 1713.xx

Tramos de plumín	Número de tramos de plumín																						
	1	1	1	1	1	1	1	1	1	1	1	1	1	1	1	1	1	1	1	1			
Pie de plumín 7 m	1	1	1	1	1	1	1	1	1	1	1	1	1	1	1	1	1	1	1	1			
Tramo de plumín 3 m		1		1		1		1		1		1		1		1		1		1			
Tramo de plumín 6 m	1	1			1	1			1	1			1	1			1	1		1			
Tramo de plumín 12 m				1	1	1	1	2	2	2	2	3	3	3	3	4	4	4	4	5	5	5	5
Cabeza de plumín 7 m	1	1	1	1	1	1	1	1	1	1	1	1	1	1	1	1	1	1	1	1	1	1	1
Longitud de plumín [m]	20	23	26	29	32	35	38	41	44	47	50	53	56	59	62	65	68	71	74	77	80	83	
Plumín auxiliar fijo	✓	✓	✓	✓	✓	✓	✓	✓	✓	✓	✓	✓	✓	✓	✓	✓	✓	✓	✓	✓	✓	✓	✓

Para conocer la configuración de pluma principal, consultar la tabla en la página 18.

Capacidades con plumín abatible

Tabla de carga [t] con pluma principal 20 m, ángulo de 88°

Radio [m]	Longitud de plumín [m]					
	20	32	44	56	68	83
9	60.0					
11	52.2	46.1				
13	42.1	37.8	30.3			
16	32.1	29.4	26.8	18.8		
18	27.6	25.2	22.8	17.9	12.0	
20	23.9	22.5	20.2	16.8	11.6	
22	19.7	19.7	18.0	15.7	11.0	6.9
24		17.7	16.2	14.7	10.5	6.7
36			9.9	8.7	7.7	5.4
48				5.9	5.0	3.9
60					3.4	2.4
65					2.8	

Contrapeso trasero de 82.3 t y contrapeso central de 36 t

Tabla de carga [t] con pluma principal 29 m, ángulo de 88°

Radio [m]	Longitud de plumín [m]					
	20	32	44	56	68	83
8.1	60.0					
11	53.6	43.3				
14	40.4	35.5	27.7			
16	34.2	30.9	26.1	17.6		
20	25.6	23.6	21.4	16.1	11.0	
22	22.2	20.7	18.9	15.3	10.4	6.4
24		18.6	17.0	14.7	10.0	6.3
32		13.3	12.1	10.7	8.5	5.6
36			10.4	9.1	8.0	5.3
46			7.4	6.6	5.6	4.3
48				6.3	5.2	4.0
65					3.0	2.2

Contrapeso trasero de 82.3 t y contrapeso central de 36 t

Tabla de carga [t] con pluma principal 41 m, ángulo de 88°

Radio [m]	Longitud de plumín [m]					
	20	32	44	56	68	83
8.6	52.2					
11	46.1	34.9				
14	38.8	31.4	23.7			
18	29.7	25.6	21.2	15.3		
20	26.3	23.3	20.0	14.7	9.8	
22	23.2	20.8	18.3	13.9	9.5	5.5
32		13.6	12.2	11.0	8.1	5.1
38			10.0	8.7	7.4	4.7
46			7.7	6.8	5.7	4.2
48				6.4	5.4	4.0
60					3.7	2.9
70					2.4	

Contrapeso trasero de 82.3 t y contrapeso central de 36 t

Tabla de carga [t] con pluma principal 50 m, ángulo de 88°

Radio [m]	Longitud de plumín [m]					
	20	32	44	56	68	83
8.9	39.8					
11	35.8					
12	34.0	27.4				
14	30.6	25.3	19.3			
18	25.4	21.2	17.1	13.0		
20	23.4	19.8	16.0	12.2	8.7	
22	21.9	18.2	14.9	11.5	8.5	4.8
24		16.9	14.0	10.8	8.4	4.8
36			10.5	8.6	6.7	4.5
55				5.1	4.4	3.1
65					3.2	2.3
70					2.5	

Contrapeso trasero de 82.3 t y contrapeso central de 36 t

Tabla de carga [t] con pluma principal 65 m, ángulo de 88°

Radio [m]	Longitud de plumín [m]					
	20	29	35	41	47	53
9.4	26.2					
12	23.6	20.0				
13	22.5	19.2	16.7			
14	21.5	18.4	16.1	14.1		
16	19.8	17.1	14.9	13.4	11.9	
20	17.1	14.8	12.9	11.8	10.5	9.3
26		12.4	10.8	9.8	8.8	7.8
32		11.2	9.6	8.7	7.8	7.0
38			8.9	7.9	7.0	6.2
44				7.3	6.4	5.6
50					4.7	5.1
55						4.8

Contrapeso trasero de 82.3 t y contrapeso central de 36 t

TLT 13147978. Estas tablas de cargas sirven únicamente como información. Para trabajos de elevación consultar las tablas de cargas de la cabina o el manual. De lo contrario, lo recomendamos que planifique su trabajo de elevación con Crane Planner 2.0.



www.liebherr.com/CranePlanner

Crane Planner 2.0

Capacidades con plumín abatible

Tabla de carga [t] con pluma principal 20 m, ángulo de 83°

Radio [m]	Longitud de plumín [m]					
	20	32	44	56	68	83
11.3	59.9					
16	36.9	33.5				
20	27.2	24.5	22.1			
22	23.8	21.7	19.6	16.3		
24	20.4	19.3	17.4	15.7		
26		17.6	15.8	14.3	10.2	
28		16.0	14.4	13.0	10.0	
30		14.7	13.1	11.8	9.7	6.1
46			7.5	6.6	5.6	4.6
55				5.1	4.2	3.1
65					3.1	2.1
70					2.5	

Contrapeso trasero de 82.3 t y contrapeso central de 36 t

Tabla de carga [t] con pluma principal 29 m, ángulo de 83°

Radio [m]	Longitud de plumín [m]					
	20	32	44	56	68	83
12.4	56.3					
16	42.7	36.2				
20	30.7	27.5	24.0			
22	26.6	24.1	21.7			
24	23.6	21.5	19.5	15.3		
28		17.4	15.9	14.1	9.7	
32		14.7	13.2	11.9	9.1	5.8
38			10.6	9.4	8.0	5.4
48			7.6	6.8	5.7	4.5
55				5.5	4.6	3.5
60				4.7	3.9	3.0
70					2.8	2.0

Contrapeso trasero de 82.3 t y contrapeso central de 36 t

Tabla de carga [t] con pluma principal 41 m, ángulo de 83°

Radio [m]	Longitud de plumín [m]					
	20	32	44	56	68	83
13.8	42.7					
18	34.9	29.0				
22	27.8	24.0	20.3			
26	22.7	20.1	17.6	13.6		
28		18.7	16.4	13.2	8.9	
36		13.4	12.1	10.8	8.1	5.2
44			9.3	8.1	6.8	4.6
48			8.2	7.2	6.0	4.4
55				5.9	4.8	3.6
60				5.0	4.1	3.2
65					3.6	2.7
70					3.0	2.2

Contrapeso trasero de 82.3 t y contrapeso central de 36 t

Tabla de carga [t] con pluma principal 50 m, ángulo de 83°

Radio [m]	Longitud de plumín [m]					
	20	32	44	56	68	83
14.9	31.8					
20	25.2	21.4				
22	23.3	19.7	15.7			
26	20.5	17.2	14.3	11.1		
28	19.5	16.4	13.6	10.7		
30		15.7	13.1	10.4	8.0	
34		14.4	12.0	9.6	7.6	4.7
40			10.5	8.6	6.8	4.5
48			8.4	7.2	5.8	4.0
55				5.9	5.0	3.5
60				5.1	4.3	3.2
70					3.2	2.3

Contrapeso trasero de 82.3 t y contrapeso central de 36 t

Tabla de carga [t] con pluma principal 65 m, ángulo de 83°

Radio [m]	Longitud de plumín [m]					
	20	29	38	44	50	53
16.8	21.2					
20	18.8	16.4				
24	16.3	14.2	11.9	10.5		
26	15.5	13.4	11.2	10.2	9.1	
28	14.9	12.8	10.8	9.8	8.8	8.3
34		11.4	9.6	8.7	7.9	7.3
40			8.7	7.8	7.0	6.5
44			8.2	7.3	6.5	6.1
48				6.9	6.1	5.7
50				6.7	5.9	5.5
55					5.5	5.1
60						4.7

Contrapeso trasero de 82.3 t y contrapeso central de 36 t

TLT 13147978. Estas tablas de cargas sirven únicamente como información. Para trabajos de elevación consultar las tablas de cargas de la cabina o el manual. De lo contrario, lo recomendamos que planifique su trabajo de elevación con Crane Planner 2.0.

Capacidades con plumín abatible

Tabla de carga [t] con pluma principal 20 m, ángulo de 75°

Radio [m]	Longitud de plumín [m]					
	20	32	44	56	68	83
18	39.5					
20	33.4					
22	28.8	25.5				
24	25.2	22.9				
32		14.9	13.6	11.7		
36		12.8	11.6	10.2		
38		12.0	10.7	9.5	8.1	
44			8.6	7.7	6.6	5.1
50			7.2	6.2	5.2	4.2
60				4.7	3.7	2.8
65					3.2	2.3
70					2.7	

Contrapeso trasero de 82.3 t y contrapeso central de 36 t

Tabla de carga [t] con pluma principal 29 m, ángulo de 75°

Radio [m]	Longitud de plumín [m]					
	20	32	44	56	68	83
19	44.8					
24	30.6	24.0				
28	23.9	21.4				
30		18.9	17.2			
36		14.4	13.1	11.9		
40		12.5	11.4	10.1	8.4	
46			9.1	8.1	7.0	4.9
48			8.6	7.6	6.4	4.9
50			8.2	7.1	6.0	4.7
55				6.0	5.1	4.1
70					3.2	2.3
75					2.7	

Contrapeso trasero de 82.3 t y contrapeso central de 36 t

Tabla de carga [t] con pluma principal 41 m, ángulo de 75°

Radio [m]	Longitud de plumín [m]					
	20	32	44	56	68	83
22.1	31.8					
28	25.8	22.7				
30	24.0	20.8				
34		18.0	16.0			
36		16.5	14.8			
38		15.1	13.7	11.8		
42		13.1	11.9	10.4		
44		12.2	11.0	9.7	7.8	
50			9.0	7.9	6.8	4.5
55			7.8	6.7	5.7	4.2
65				5.1	4.1	3.2
75					3.1	2.2

Contrapeso trasero de 82.3 t y contrapeso central de 36 t

Tabla de carga [t] con pluma principal 50 m, ángulo de 75°

Radio [m]	Longitud de plumín [m]					
	20	32	44	56	68	83
24.4	22.7					
30	19.6	16.8				
34	17.8	15.3				
36		14.7	12.4			
40		13.4	11.4	9.0		
46		12.1	10.2	8.3	6.5	
48			9.7	8.0	6.5	
55			8.3	6.9	5.7	3.8
60				6.0	5.2	3.6
70				4.3	3.8	2.9
75					3.3	2.4
80					2.8	

Contrapeso trasero de 82.3 t y contrapeso central de 36 t

Tabla de carga [t] con pluma principal 65 m, ángulo de 75°

Radio [m]	Longitud de plumín [m]					
	20	26	32	38	44	53
28.3	16.2					
32	15.0	13.9				
34	14.4	13.2	12.1			
36	13.9	12.7	11.7	10.1		
38	13.3	12.2	11.2	9.9		
40		11.7	10.8	9.6	8.7	
44		10.9	10.0	8.9	8.1	6.9
50			9.1	7.9	7.3	6.1
55				7.4	6.6	5.6
60					6.2	5.1
65						4.7
70						4.3

Contrapeso trasero de 82.3 t y contrapeso central de 36 t

TLT 13147978. Estas tablas de cargas sirven únicamente como información. Para trabajos de elevación consultar las tablas de cargas de la cabina o el manual. De lo contrario, lo recomendamos que planifique su trabajo de elevación con Crane Planner 2.0.

Capacidades con plumín abatible

Tabla de carga [t] con pluma principal 20 m, ángulo de 65°

Radio [m]	Longitud de plumín [m]					
	20	32	44	56	68	83
22.9	24.0					
30	21.2	18.9				
36		14.4				
38		13.4	12.1			
42		11.6	10.3			
44			9.5	8.3		
50			8.0	6.9		
55				5.8	4.9	
60				5.1	4.2	3.0
65				4.4	3.5	2.5
70					3.0	2.1
75					2.6	

Contrapeso trasero de 82.3 t y contrapeso central de 36 t

Tabla de carga [t] con pluma principal 32 m, ángulo de 65°

Radio [m]	Longitud de plumín [m]					
	20	32	44	56	68	83
30	25.0					
32	23.1					
36		18.9				
42		14.4	12.7			
44		13.5	12.1			
46		12.6	11.2			
50			9.7	8.6		
55			8.4	7.3		
65				5.5	4.4	3.3
70				4.8	3.8	2.8
75					3.3	2.3
80					2.9	

Contrapeso trasero de 82.3 t y contrapeso central de 36 t

Tabla de carga [t] con pluma principal 44 m, ángulo de 65°

Radio [m]	Longitud de plumín [m]					
	20	32	44	56	68	83
33	20.3					
34	19.6					
40	16.1	15.5				
48		12.3	11.7			
50		11.7	11.1			
55			9.7	8.5		
60			8.5	7.3		
65				6.3	5.2	
70				5.5	4.5	3.2
75				4.8	3.8	2.9
80					3.3	2.4
85					2.9	

Contrapeso trasero de 82.3 t y contrapeso central de 36 t

Tabla de carga [t] con pluma principal 56 m, ángulo de 65°

Radio [m]	Longitud de plumín [m]					
	20	32	44	56	68	83
38.1	15.1					
46	12.0	11.3				
48		10.7				
50		10.2				
55		9.0	8.2			
60			7.3	6.4		
65			6.5	5.7		
70				5.1	4.2	
75				4.6	3.7	2.5
80				4.1	3.3	2.2
85					2.9	
90					2.5	

Contrapeso trasero de 82.3 t y contrapeso central de 36 t

Tabla de carga [t] con pluma principal 65 m, ángulo de 65°

Radio [m]	Longitud de plumín [m]					
	20	32	38	44	50	53
41.9	11.6					
42	11.6					
44	11.0					
46	10.5					
48	10.0					
50		8.5				
55		7.6	7.2			
60		6.8	6.4	5.9	5.4	
65			5.7	5.3	4.8	4.5
70				4.7	4.3	4.0
75					3.8	3.6
80						3.2

Contrapeso trasero de 82.3 t y contrapeso central de 36 t

TLT 13147978. Estas tablas de cargas sirven únicamente como información. Para trabajos de elevación consultar las tablas de cargas de la cabina o el manual. De lo contrario, lo recomendamos que planifique su trabajo de elevación con Crane Planner 2.0.

Plumín abatible 1916.xx

Longitud de plumín 20-95 m

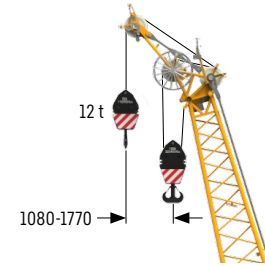
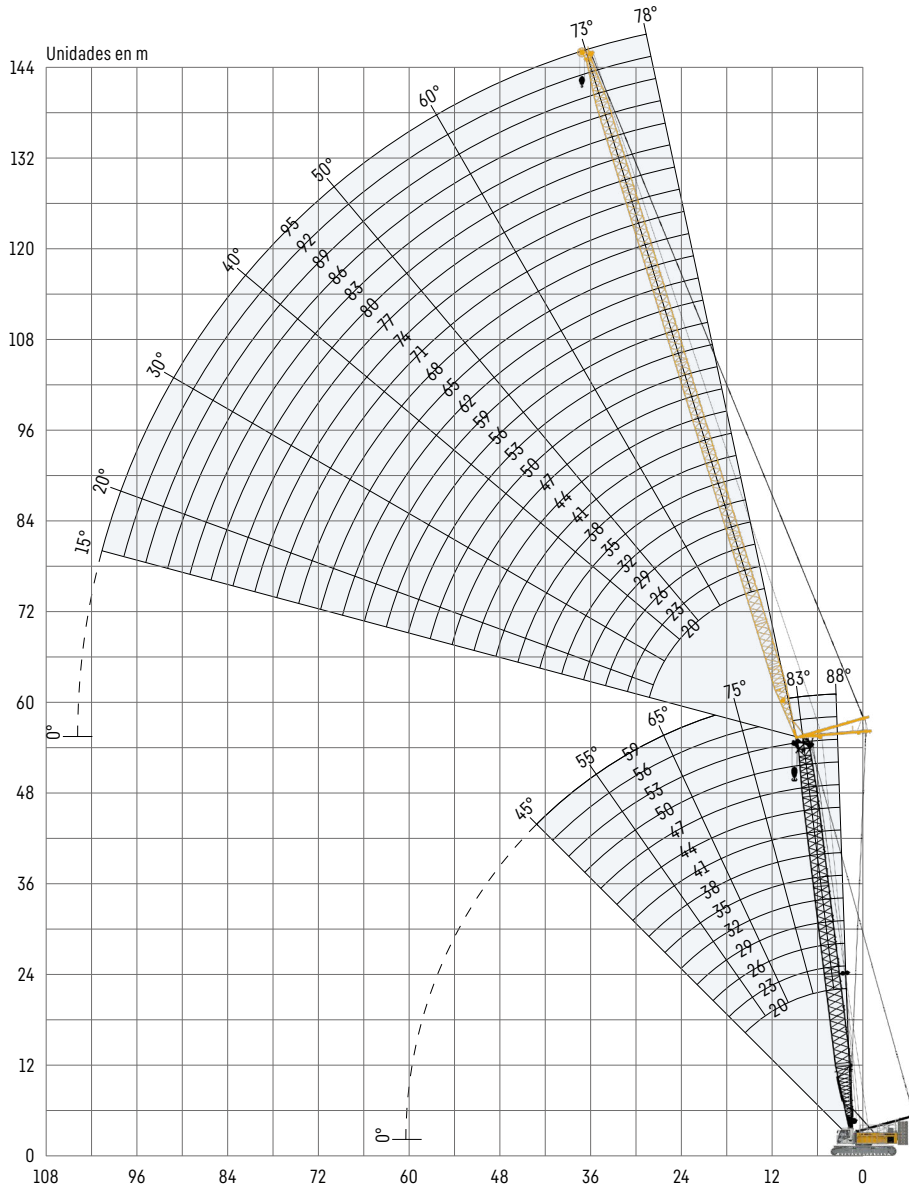

Plumín auxiliar fijo 12 t (opción)
La carga máx. del plumín auxiliar es de 12 t.

Configuración de plumín abatible 1916.xx

Tramos de plumín	Número de tramos de plumín																									
Pie de plumín 7 m	1	1	1	1	1	1	1	1	1	1	1	1	1	1	1	1	1	1	1	1						
Tramo de plumín 3 m		1		1		1		1		1		1		1		1		1		1						
Tramo de plumín 6 m	1	1			1	1		1	1		1	1		1	1		1	1		1						
Tramo de plumín 12 m			1	1	1	1	2	2	2	2	3	3	3	3	4	4	4	4	5	5	5	5	6	6	6	6
Cabeza de plumín 7 m	1	1	1	1	1	1	1	1	1	1	1	1	1	1	1	1	1	1	1	1	1	1	1	1	1	1
Longitud de plumín [m]	20	23	26	29	32	35	38	41	44	47	50	53	56	59	62	65	68	71	74	77	80	83	86	89	92	95
Plumín auxiliar fijo	✓	✓	✓	✓	✓	✓	✓	✓	✓	✓	✓	✓	✓	✓	✓	✓	✓	✓	✓	✓	✓	✓	✓	✓	✓	✓

Para conocer la configuración de pluma principal, consultar la tabla en la página 18.

Capacidades con plumín abatible

Tabla de carga [t] con pluma principal 20 m, ángulo de 88°

Radio [m]	Longitud de plumín [m]					
	20	35	50	65	80	95
9	70.7					
11	70.7	49.6				
16	47.7	40.2	28.5			
18	39.9	34.6	27.0	16.7		
22	28.4	26.9	23.7	15.4	9.7	
24		23.7	21.3	14.7	9.4	5.3
32		16.5	15.0	12.8	8.6	5.1
38			12.1	10.6	8.0	4.8
46			9.5	8.0	6.7	4.3
60				5.3	4.3	3.0
70					3.1	2.0
75					2.5	

Contrapeso trasero de 82.3 t y contrapeso central de 36 t

Tabla de carga [t] con pluma principal 29 m, ángulo de 88°

Radio [m]	Longitud de plumín [m]					
	20	35	50	65	80	95
8.1	69.2					
12	50.3	42.1				
16	38.3	33.1	25.8			
18	34.2	29.4	24.3	15.0		
20	30.8	26.7	22.1	14.7		
22	28.2	24.4	20.5	14.3	8.8	
24		22.3	19.0	13.8	8.7	4.8
32		17.3	15.0	11.8	8.2	4.7
38			13.0	10.4	7.6	4.6
46			10.9	8.9	6.8	4.1
65				6.2	4.8	3.0
80					3.6	2.1

Contrapeso trasero de 82.3 t y contrapeso central de 36 t

Tabla de carga [t] con pluma principal 41 m, ángulo de 88°

Radio [m]	Longitud de plumín [m]					
	20	35	50	65	80	95
8.6	55.5					
12	46.8	34.6				
16	37.7	29.7	21.8			
18	34.3	27.5	20.8	12.6		
20	31.2	25.5	19.5	12.4		
22	28.5	23.8	18.5	12.2	7.6	
24		22.1	17.6	12.0	7.4	
34		16.3	14.2	10.7	7.2	4.0
48			10.4	8.4	6.3	3.7
55				7.1	5.8	3.3
70					3.9	2.3
80					3.0	

Contrapeso trasero de 82.3 t y contrapeso central de 36 t

Tabla de carga [t] con pluma principal 50 m, ángulo de 88°

Radio [m]	Longitud de plumín [m]					
	20	35	50	65	80	95
8.9	42.2					
12	36.5	27.2				
16	30.2	23.6	17.5			
20	25.7	20.3	15.2	10.8		
22	24.1	19.1	14.4	10.5	6.4	
24		17.9	13.6	10.2	6.4	
26		16.9	13.0	9.8	6.3	3.3
34		14.5	11.3	8.6	6.1	3.3
40			10.2	7.8	5.6	3.2
48			8.8	6.9	4.9	2.8
65				5.0	3.5	2.0
80					2.4	

Contrapeso trasero de 82.3 t y contrapeso central de 36 t

Tabla de carga [t] con pluma principal 59 m, ángulo de 88°

Radio [m]	Longitud de plumín [m]					
	20	29	38	47	56	62
9.2	33.4					
12	29.7	24.9				
13	28.3	24.0	19.8			
16	25.0	21.3	18.0	15.1		
18	23.3	19.7	16.8	14.2	11.9	10.1
24	12.1	16.3	13.7	11.8	10.0	9.0
26		15.5	13.1	11.3	9.6	8.6
36			11.0	9.5	8.1	7.2
42				8.6	7.4	6.5
50				7.2	6.5	5.8
55					6.1	5.4
60						4.9

Contrapeso trasero de 82.3 t y contrapeso central de 36 t

TLT 13147978. Estas tablas de cargas sirven únicamente como información. Para trabajos de elevación consultar las tablas de cargas de la cabina o el manual. De lo contrario, lo recomendamos que planifique su trabajo de elevación con Crane Planner 2.0.



www.liebherr.com/CranePlanner

Crane Planner 2.0

Capacidades con plumín abatible

Tabla de carga [t] con pluma principal 20 m, ángulo de 83°

Radio [m]	Longitud de plumín [m]					
	20	35	50	65	80	95
11.3	70.7					
14	69.9					
18	47.6	39.4				
22	34.0	32.7	25.0			
26		24.4	22.4	14.6		
30		20.1	20.1	13.9	9.0	
32		18.5	18.0	13.5	8.8	
38		14.6	13.8	12.1	8.2	4.9
46			10.6	9.5	7.3	4.4
65				5.1	4.4	3.1
75					3.1	2.0
80					2.4	

Contrapeso trasero de 82.3 t y contrapeso central de 36 t

Tabla de carga [t] con pluma principal 29 m, ángulo de 83°

Radio [m]	Longitud de plumín [m]					
	20	35	50	65	80	95
12.4	57.7					
18	38.8	34.1				
20	34.6	30.4				
24	28.5	25.0	21.2			
28		21.5	18.5	13.5		
30		20.1	17.6	13.2	8.5	
36		16.9	14.8	12.0	8.0	4.7
38		16.0	14.1	11.6	7.8	4.6
50			10.7	8.9	6.8	4.0
65				6.6	5.2	3.2
80					3.9	2.3
85						2.1

Contrapeso trasero de 82.3 t y contrapeso central de 36 t

Tabla de carga [t] con pluma principal 41 m, ángulo de 83°

Radio [m]	Longitud de plumín [m]					
	20	35	50	65	80	95
13.8	45.6					
20	34.8	27.6				
24	29.5	24.1	18.8			
26	27.9	22.9	18.0			
30		20.9	16.8	11.8		
34		18.7	15.7	11.5	7.3	
40		16.4	14.2	10.7	7.1	4.0
42			13.6	10.4	7.0	4.0
48			12.0	9.6	6.7	3.8
60				7.7	5.9	3.2
75					4.6	2.4
85					3.4	

Contrapeso trasero de 82.3 t y contrapeso central de 36 t

Tabla de carga [t] con pluma principal 50 m, ángulo de 83°

Radio [m]	Longitud de plumín [m]					
	20	35	50	65	80	95
14.9	34.4					
20	27.6	22.2				
24	23.9	19.3	14.4			
28	21.8	17.4	13.5			
32		16.2	12.6	9.7		
34		15.6	12.2	9.4	6.3	
38		14.6	11.4	8.8	6.2	3.2
44			10.4	8.0	5.7	3.2
50			9.6	7.4	5.3	3.0
60				6.3	4.5	2.6
75					3.5	
85					2.9	

Contrapeso trasero de 82.3 t y contrapeso central de 36 t

Tabla de carga [t] con pluma principal 59 m, ángulo de 83°

Radio [m]	Longitud de plumín [m]					
	20	29	38	47	56	62
16	27.3					
20	23.6	20.2				
22	21.8	18.7	16.0			
24	20.5	17.7	14.9	12.6		
28	18.8	16.0	13.6	11.8	10.1	
30		15.4	13.1	11.4	9.8	8.8
36		14.0	11.8	10.2	8.9	7.9
40			11.1	9.6	8.3	7.4
48				8.5	7.3	6.5
60					6.2	5.5
65						5.1
70						4.3

Contrapeso trasero de 82.3 t y contrapeso central de 36 t

TLT 13147978. Estas tablas de cargas sirven únicamente como información. Para trabajos de elevación consultar las tablas de cargas de la cabina o el manual. De lo contrario, lo recomendamos que planifique su trabajo de elevación con Crane Planner 2.0.

Capacidades con plumín abatible

Tabla de carga [t] con pluma principal 20 m, ángulo de 75°

Radio [m]	Longitud de plumín [m]					
	20	35	50	65	80	95
18	51.8					
24	36.3	34.4				
26	32.2	32.3				
30		25.3	22.6			
34		20.4	21.4			
36		18.4	19.4	13.2		
48			11.8	11.3	7.5	
55			9.2	8.8	7.0	4.0
60				7.1	6.6	3.7
70				5.1	4.6	3.0
80					3.2	2.4
85					2.4	2.1

Contrapeso trasero de 82.3 t y contrapeso central de 36 t

Tabla de carga [t] con pluma principal 29 m, ángulo de 75°

Radio [m]	Longitud de plumín [m]					
	20	35	50	65	80	95
19	45.5					
26	30.5	27.8				
28	28.2	25.5				
32		21.9	19.5			
36		19.2	17.4			
42		16.2	14.7	12.0		
44		15.3	13.9	11.7		
50			11.9	10.1	7.2	
55			10.7	9.1	6.9	3.9
70				6.6	5.5	3.1
85					4.0	2.3
90						2.0

Contrapeso trasero de 82.3 t y contrapeso central de 36 t

Tabla de carga [t] con pluma principal 41 m, ángulo de 75°

Radio [m]	Longitud de plumín [m]					
	20	35	50	65	80	95
22.1	34.2					
30	25.6	23.0				
32	23.7	22.0				
36		19.9	16.8			
42		16.4	15.3	11.0		
46		14.5	13.9	10.8		
48			13.2	10.6	6.8	
55			11.0	9.9	6.5	3.7
60			9.7	8.9	6.3	3.5
70				7.0	5.8	3.0
85					4.3	2.3
90					3.7	2.1

Contrapeso trasero de 82.3 t y contrapeso central de 36 t

Tabla de carga [t] con pluma principal 50 m, ángulo de 75°

Radio [m]	Longitud de plumín [m]					
	20	35	50	65	80	95
24.4	25.5					
32	21.5	17.6				
34	20.6	16.9				
36		16.2				
42		14.6	11.8			
44		14.1	11.3	8.8		
48		13.0	10.7	8.4		
50			10.3	8.3	5.6	
60			9.0	7.1	5.2	2.9
65				6.5	4.8	2.8
80					3.7	2.1
90					3.1	

Contrapeso trasero de 82.3 t y contrapeso central de 36 t

Tabla de carga [t] con pluma principal 59 m, ángulo de 75°

Radio [m]	Longitud de plumín [m]					
	20	35	44	50	56	62
28	20.6					
34	18.1	14.1				
40		12.6	11.2	10.3		
42		12.1	10.9	10.0	8.9	
44		11.7	10.5	9.7	8.9	
46		11.4	10.2	9.4	8.6	7.7
50		10.8	9.5	8.9	8.0	7.2
55			8.9	8.2	7.4	6.6
60			8.2	7.6	6.8	6.1
65				7.1	6.4	5.6
70					6.0	5.2
75						4.9

Contrapeso trasero de 82.3 t y contrapeso central de 36 t

TLT 13147978. Estas tablas de cargas sirven únicamente como información. Para trabajos de elevación consultar las tablas de cargas de la cabina o el manual. De lo contrario, lo recomendamos que planifique su trabajo de elevación con Crane Planner 2.0.

Capacidades con plumín abatible

Tabla de carga [t] con pluma principal 20 m, ángulo de 65°

Radio [m]	Longitud de plumín [m]					
	20	35	50	65	80	95
24	34.8					
28	28.8					
30	26.5					
38		19.3				
42		17.0	16.4			
46			14.6			
50			13.0	11.8		
55			11.5	10.7		
60				9.4	6.9	
70				6.6	6.2	3.2
85					3.8	2.4
90						2.1

Contrapeso trasero de 82.3 t y contrapeso central de 36 t

Tabla de carga [t] con pluma principal 29 m, ángulo de 65°

Radio [m]	Longitud de plumín [m]					
	20	35	50	65	80	95
28	27.4					
34	21.5					
36		19.4				
40		17.0				
44		15.1	14.4			
48		13.4	12.8			
55			10.7	9.9		
65				7.6	6.5	
70				6.7	6.0	3.2
75				6.0	5.2	3.0
85					4.1	2.5
95						2.1

Contrapeso trasero de 82.3 t y contrapeso central de 36 t

Tabla de carga [t] con pluma principal 41 m, ángulo de 65°

Radio [m]	Longitud de plumín [m]					
	20	35	50	65	80	95
31.7	21.4					
34	19.7					
36	18.3					
38	17.1					
42		14.3				
50		11.4	10.7			
60			8.2	7.3		
70				5.7	4.6	
75				5.0	4.0	2.8
85					3.0	
90					2.6	
95					2.2	

Contrapeso trasero de 82.3 t y contrapeso central de 36 t

Tabla de carga [t] con pluma principal 50 m, ángulo de 65°

Radio [m]	Longitud de plumín [m]					
	20	35	50	65	80	86
35.5	17.0					
36	16.7					
38	15.7					
42	13.8					
46		11.4				
50		10.2				
55		8.9	8.0			
65			6.3	5.1		
70			5.6	4.4	3.3	
75				3.9	2.8	2.4
80				3.4	2.3	
85				3.0		

Contrapeso trasero de 82.3 t y contrapeso central de 36 t

Tabla de carga [t] con pluma principal 59 m, ángulo de 65°

Radio [m]	Longitud de plumín [m]					
	20	29	41	50	59	62
39.4	13.1					
40	12.8					
42	12.1					
44	11.5					
46	11.0	10.1				
55		8.1	7.1			
60			6.3	5.6		
65			5.6	5.0	4.1	4.0
70				4.4	3.6	3.4
75				3.9	3.1	3.0
80					2.7	2.5
85					2.3	2.2

Contrapeso trasero de 82.3 t y contrapeso central de 36 t

TLT 13147978. Estas tablas de cargas sirven únicamente como información. Para trabajos de elevación consultar las tablas de cargas de la cabina o el manual. De lo contrario, lo recomendamos que planifique su trabajo de elevación con Crane Planner 2.0.

Plumín fijo 1008.xx

Longitud de plumín 11-26 m

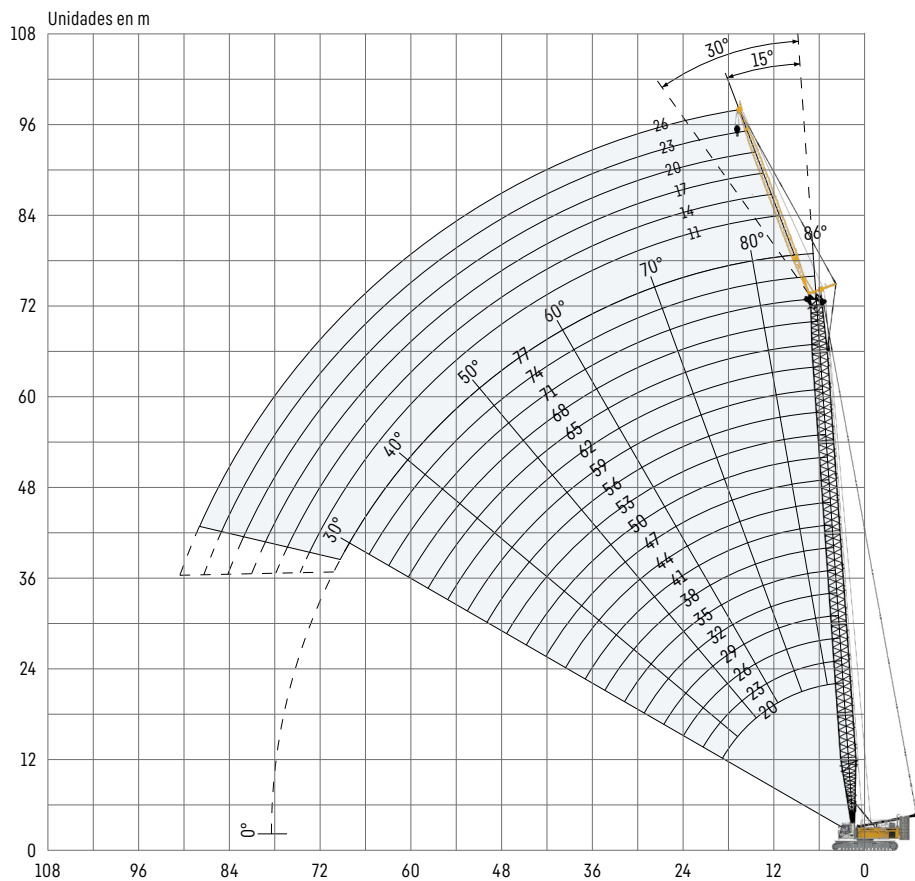

Configuración de plumín fijo 1008.xx

Tramos de plumín	Número de tramos de plumín					
	1	1	1	1	1	1
Pie de plumín 5.5 m	1	1	1	1	1	1
Tramo de plumín 3 m		1		1		1
Tramo de plumín 6 m			1	1	2	2
Cabeza de plumín 5.5 m	1	1	1	1	1	1
Longitud de plumín [m]	11	14	17	20	23	26

Para conocer la configuración de pluma principal, consultar la tabla en la página 18.

Capacidades con plumín fijo 15°

Tabla de carga [t] con pluma principal 20 m

Radio [m]	Longitud de plumín [m]			
	11	14	20	26
9	35.9			
10	35.9	34.1		
11	35.9	33.3	27.4	
12	35.9	32.6	26.4	19.7
18	34.3	28.2	21.1	16.3
26	25.6	22.2	15.8	12.6
32		18.3	13.0	10.5
34			12.4	9.9
36			12.1	9.4
38			11.5	9.0
42				8.3
44				8.0

Contrapeso trasero de 82.3 t y contrapeso central de 36 t

Tabla de carga [t] con pluma principal 35 m

Radio [m]	Longitud de plumín [m]			
	11	14	20	26
7	35.9			
8	35.9	35.4		
10	35.9	34.2	27.9	
13	35.9	32.7	25.5	18.7
22	35.5	29.2	20.4	15.1
32	23.1	23.4	16.0	12.3
40	16.6	16.9	13.3	10.4
44		14.6	12.4	9.6
46		13.6	12.1	9.2
48			12.0	8.9
50			11.6	8.7
55				8.1

Contrapeso trasero de 82.3 t y contrapeso central de 36 t

Tabla de carga [t] con pluma principal 50 m

Radio [m]	Longitud de plumín [m]			
	11	14	20	26
6.7	35.9			
8	35.9	34.3		
11	35.9	33.4	26.2	
13	35.9	32.6	25.1	17.8
20	34.4	30.2	21.6	15.6
30	24.3	24.6	18.9	13.5
40	15.7	16.0	15.7	11.7
50	10.7	10.9	11.4	9.9
55	8.9	9.1	9.5	9.2
60			8.0	8.3
65			6.7	7.0
70				5.9

Contrapeso trasero de 82.3 t y contrapeso central de 36 t

Tabla de carga [t] con pluma principal 65 m

Radio [m]	Longitud de plumín [m]			
	11	14	20	26
7.2	35.9			
9	35.9	31.7		
11	34.7	30.7	22.6	
14	30.8	28.4	21.8	16.1
24	23.1	21.9	18.1	13.9
36	17.6	17.7	15.9	12.5
40	14.8	15.1	14.8	12.3
50	9.8	10.0	10.5	10.8
65	5.3	5.4	5.8	6.2
70		4.4	4.7	5.0
75			3.7	4.1
80				3.2

Contrapeso trasero de 82.3 t y contrapeso central de 36 t

Tabla de carga [t] con pluma principal 77 m

Radio [m]	Longitud de plumín [m]		
	11	14	17
7.7	26.7		
9	26.7	23.8	
10	25.8	23.8	21.4
18	19.8	18.8	17.8
32	15.0	14.4	13.8
44	11.7	11.8	11.8
48	9.9	10.1	10.3
60	5.7	5.9	6.2
65	4.5	4.7	4.9
70	3.4	3.6	3.8
75	2.5	2.6	2.8
80			2.0

Contrapeso trasero de 82.3 t y contrapeso central de 36 t

TLT 13147978. Estas tablas de cargas sirven únicamente como información. Para trabajos de elevación consultar las tablas de cargas de la cabina o el manual. De lo contrario, lo recomendamos que planifique su trabajo de elevación con Crane Planner 2.0.



www.liebherr.com/CranePlanner

Crane Planner 2.0

Capacidades con plumín fijo 30°

Tabla de carga [t] con pluma principal 20 m

Radio [m]	Longitud de plumín [m]			
	11	14	20	26
11	34.8			
14	29.8	24.7		
16	27.1	23.7	16.4	
18	25.1	21.6	15.1	12.1
20	24.0	20.1	14.0	11.3
24	21.5	17.6	12.3	9.8
28	19.6	15.9	11.3	8.7
30	19.0	15.2	10.7	8.3
32		14.8	10.2	7.9
34		14.4	9.8	7.6
40			9.1	6.8
46				6.4

Contrapeso trasero de 82.3 t y contrapeso central de 36 t

Tabla de carga [t] con pluma principal 35 m

Radio [m]	Longitud de plumín [m]			
	11	14	20	26
10	35.9			
11	35.9	28.2		
16	30.7	24.8	16.9	
20	27.2	22.9	15.1	11.7
28	23.4	18.7	12.4	9.5
36	19.7	16.1	10.9	8.2
40	16.8	15.2	10.2	7.7
42	15.5	15.0	9.9	7.5
44	14.4	14.7	9.7	7.3
46		13.7	9.5	7.1
50			9.3	6.8
55				6.6

Contrapeso trasero de 82.3 t y contrapeso central de 36 t

Tabla de carga [t] con pluma principal 50 m

Radio [m]	Longitud de plumín [m]			
	11	14	20	26
9.4	35.9			
12	35.9	28.8		
16	32.9	26.7	17.6	
20	29.8	24.3	15.9	11.9
28	25.3	21.1	13.6	9.9
36	18.9	18.0	12.1	8.8
44	13.7	14.0	11.0	7.9
46	12.6	12.9	10.7	7.7
55	9.0	9.2	9.7	7.0
60		7.6	8.2	6.8
65			6.8	6.6
70				6.0

Contrapeso trasero de 82.3 t y contrapeso central de 36 t

Tabla de carga [t] con pluma principal 65 m

Radio [m]	Longitud de plumín [m]			
	11	14	20	26
9.9	31.9			
12	31.4	25.5		
16	28.6	24.1	16.8	
20	25.6	22.3	15.9	11.6
28	21.6	18.7	13.8	10.3
36	18.2	17.0	12.4	9.2
50	10.1	10.4	10.6	7.8
55	8.2	8.5	9.1	7.5
60	6.7	6.9	7.5	7.2
70	4.2	4.4	4.9	5.3
75			3.9	4.3
85				2.5

Contrapeso trasero de 82.3 t y contrapeso central de 36 t

Tabla de carga [t] con pluma principal 77 m

Radio [m]	Longitud de plumín [m]		
	11	14	17
10.3	24.2		
13	23.3	21.0	
14	22.4	21.0	18.5
22	17.7	16.9	15.9
30	15.3	14.6	14.1
40	13.6	13.4	12.8
42	12.9	12.8	12.7
46	11.1	11.4	11.6
60	6.0	6.2	6.5
65	4.7	4.9	5.2
75	2.6	2.8	3.0
80			2.1

Contrapeso trasero de 82.3 t y contrapeso central de 36 t

TLT 13147978. Estas tablas de cargas sirven únicamente como información. Para trabajos de elevación consultar las tablas de cargas de la cabina o el manual. De lo contrario, recomendamos que planifique su trabajo de elevación con Crane Planner 2.0.

Plumín fijo 0806.xx

Longitud de plumín 11-32 m

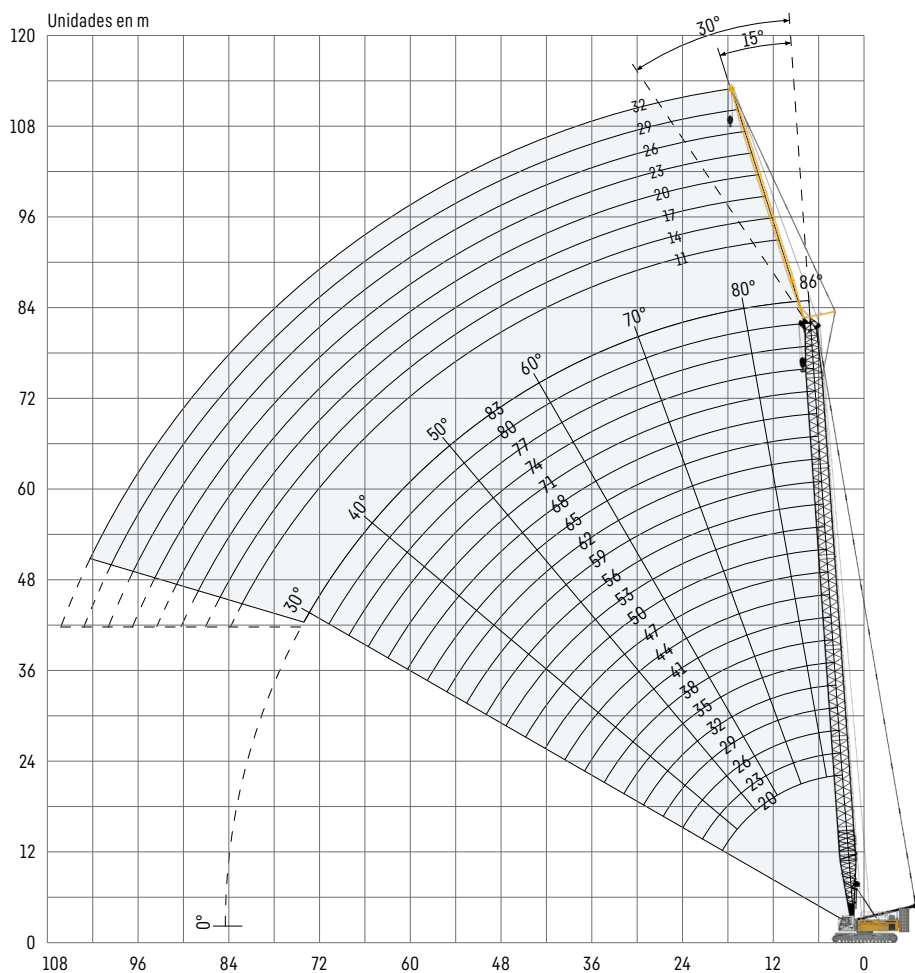

Configuración de plumín fijo 0806.xx

Tramos de plumín	Número de tramos de plumín							
	1	1	1	1	1	1	1	1
Pie de plumín 5.5 m	1	1	1	1	1	1	1	1
Tramo de plumín 3 m		1		1		1		1
Tramo de plumín 6 m			1	1	2	2	3	3
Cabeza de plumín 5.5 m	1	1	1	1	1	1	1	1
Longitud de plumín [m]	11	14	17	20	23	26	29	32

Para conocer la configuración de pluma principal, consultar la tabla en la página 18.

Capacidades con plumín fijo 15°

Tabla de carga [t] con pluma principal 20 m

Radio [m]	Longitud de plumín [m]				
	11	17	23	29	32
11	20.5				
13	19.6	12.5			
16	18.4	11.8	9.1	6.5	
18	17.7	11.3	8.8	6.2	5.1
20	15.1	9.7	7.5	5.2	4.1
28	14.6	9.5	7.3	5.0	4.0
36		8.6	6.8	4.6	3.6
38			6.5	4.5	3.5
42			6.0	4.3	3.3
46				4.2	3.2
48				4.1	3.2
50					3.1

Contrapeso trasero de 82.3 t y contrapeso central de 36 t

Tabla de carga [t] con pluma principal 35 m

Radio [m]	Longitud de plumín [m]				
	11	17	23	29	32
9	22.3				
11	21.7	13.4			
12	21.3	13.1	9.6		
14	20.9	12.7	9.4	6.7	
16	20.2	12.3	9.2	6.5	5.3
28	17.3	10.5	8.0	5.5	4.3
40	15.1	9.4	7.1	4.7	3.7
42	14.7	9.3	7.0	4.6	3.6
44		9.0	6.9	4.5	3.5
48		8.7	6.6	4.4	3.4
55			6.0	4.2	3.2
60				4.1	3.1

Contrapeso trasero de 82.3 t y contrapeso central de 36 t

Tabla de carga [t] con pluma principal 50 m

Radio [m]	Longitud de plumín [m]				
	11	17	23	29	32
6.7	20.8				
10	20.2	12.5			
12	19.9	12.2	8.7		
14	19.4	11.9	8.5	6.0	
16	19.1	11.7	8.4	5.9	4.9
32	17.1	10.2	7.5	5.1	4.1
46	13.1	9.4	6.9	4.6	3.6
48	12.2	9.3	6.9	4.5	3.5
60		8.7	6.4	4.1	3.2
65			6.1	4.1	3.1
70				4.0	3.1
75					3.1

Contrapeso trasero de 82.3 t y contrapeso central de 36 t

Tabla de carga [t] con pluma principal 65 m

Radio [m]	Longitud de plumín [m]				
	11	17	23	29	32
7.2	18.1				
10	17.8	11.4			
13	17.5	11.2	7.6		
16	17.2	11.0	7.5	5.2	4.3
34	15.9	9.9	6.8	4.7	3.9
50	10.6	9.2	6.4	4.4	3.5
60	7.3	7.8	6.3	4.2	3.4
65	6.0	6.5	6.2	4.1	3.3
75		4.5	4.9	4.0	3.1
80			4.1	4.0	3.1
85				3.7	3.1
90					3.1

Contrapeso trasero de 82.3 t y contrapeso central de 36 t

Tabla de carga [t] con pluma principal 83 m

Radio [m]	Longitud de plumín [m]				
	11	14	17	20	23
8	13.6				
10	13.4	10.5			
11	13.4	10.5	8.2		
12	13.3	10.4	8.1	6.8	
13	13.1	10.4	8.1	6.8	5.5
30	12.0	9.5	7.6	6.5	5.2
46	10.8	9.1	7.2	6.2	5.1
65	4.8	5.1	5.4	5.6	4.9
70	3.8	4.0	4.3	4.5	4.7
75	2.8	3.1	3.3	3.6	3.8
80	2.0	2.3	2.5	2.7	2.9
85					2.2

Contrapeso trasero de 82.3 t y contrapeso central de 36 t

TLT 13147978. Estas tablas de cargas sirven únicamente como información. Para trabajos de elevación consultar las tablas de cargas de la cabina o el manual. De lo contrario, lo recomendamos que planifique su trabajo de elevación con Crane Planner 2.0.



www.liebherr.com/CranePlanner

Crane Planner 2.0

Capacidades con plumín fijo 30°

Tabla de carga [t] con pluma principal 20 m

Radio [m]	Longitud de plumín [m]				
	11	17	23	29	32
13	17.6				
16	16.8	10.6			
18	16.4	10.4			
20	16.0	10.1	7.8		
22	15.5	9.9	7.6	5.3	
30	12.9	8.8	6.8	4.7	3.7
36		8.0	6.1	4.4	3.4
42			5.7	4.2	3.3
44				4.2	3.2
46				4.2	3.1
48				4.1	3.1
50					3.1

Contrapeso trasero de 82.3 t y contrapeso central de 36 t

Tabla de carga [t] con pluma principal 35 m

Radio [m]	Longitud de plumín [m]				
	11	17	23	29	32
11	18.9				
14	18.2	11.1			
18	17.4	10.6	8.1		
22	16.7	10.3	7.8	5.4	4.2
34	14.2	9.4	7.0	4.7	3.7
44	11.0	8.4	6.2	4.4	3.3
46		8.2	6.0	4.3	3.3
48		8.0	5.9	4.3	3.3
50		8.0	5.9	4.3	3.2
55			5.7	4.2	3.2
60				4.2	3.1
65					3.1

Contrapeso trasero de 82.3 t y contrapeso central de 36 t

Tabla de carga [t] con pluma principal 50 m

Radio [m]	Longitud de plumín [m]				
	11	17	23	29	32
9.4	18.0				
14	17.5	10.7			
18	17.2	10.4	7.6		
22	16.9	10.1	7.5	5.2	
24	16.8	10.1	7.4	5.1	4.0
36	15.6	9.5	7.0	4.7	3.6
46	13.4	8.9	6.6	4.4	3.4
55	9.7	8.3	6.0	4.2	3.2
60		8.1	5.9	4.2	3.2
65			5.7	4.1	3.1
70				4.1	3.1
75				4.1	3.1

Contrapeso trasero de 82.3 t y contrapeso central de 36 t

Tabla de carga [t] con pluma principal 65 m

Radio [m]	Longitud de plumín [m]				
	11	17	23	29	32
9.9	16.3				
14	16.1	10.1			
18	16.0	9.9	7.0		
22	15.8	9.8	6.9	4.7	
24	15.8	9.7	6.8	4.7	3.9
36	15.4	9.3	6.7	4.5	3.6
48	11.7	9.1	6.5	4.4	3.4
70	5.0	5.6	5.9	4.2	3.2
75		4.6	5.1	4.2	3.2
80			4.2	4.2	3.2
85				3.8	3.2
90					3.2

Contrapeso trasero de 82.3 t y contrapeso central de 36 t

Tabla de carga [t] con pluma principal 83 m

Radio [m]	Longitud de plumín [m]				
	11	14	17	20	23
10.5	12.7				
13	12.6	10.1			
16	12.4	10.0	7.9		
18	12.3	9.9	7.8	6.8	5.5
34	11.8	9.6	7.6	6.7	5.4
48	10.4	9.5	7.5	6.6	5.3
50	9.6	9.4	7.5	6.6	5.3
55	7.9	8.2	7.5	6.6	5.3
60	6.4	6.7	7.0	6.6	5.3
65	5.1	5.4	5.7	6.0	5.3
80	2.1	2.4	2.7	2.9	3.2
85				2.1	2.4

Contrapeso trasero de 82.3 t y contrapeso central de 36 t

TLT 13147978. Estas tablas de cargas sirven únicamente como información. Para trabajos de elevación consultar las tablas de cargas de la cabina o el manual. De lo contrario, lo recomendamos que planifique su trabajo de elevación con Crane Planner 2.0.

Plumín fijo 0906.21

Longitud de plumín 7 m

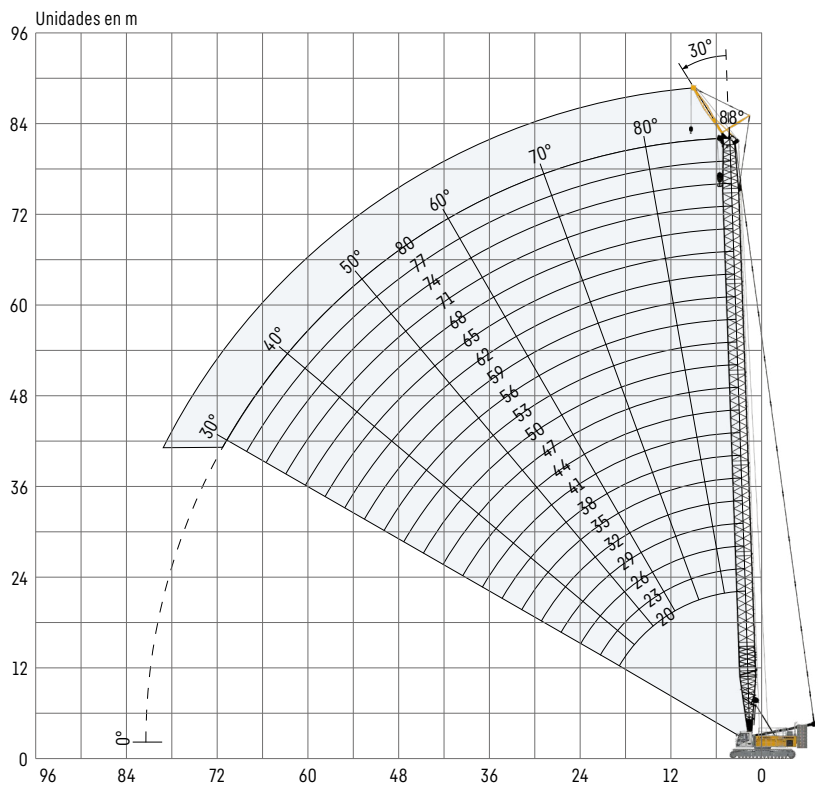

La longitud de plumín es de 7 m. Para conocer la configuración de pluma principal, consultar la tabla en la página 18.

Capacidades con plumín fijo 30°

Tabla de carga [t] con pluma principal 20 m

Radio [m]	Longitud de plumín 7 m
10	59.2
11	57.6
12	56.2
13	54.7
14	53.6
16	51.6
18	50.0
20	44.3
22	39.0
24	34.6
26	30.9

Contrapeso trasero de 82.3 t y contrapeso central de 36 t

Tabla de carga [t] con pluma principal 35 m

Radio [m]	Longitud de plumín 7 m
9	56.7
11	53.3
13	50.4
16	47.1
20	43.5
24	34.2
28	27.6
32	22.8
36	19.1
38	17.6
40	16.2

Contrapeso trasero de 82.3 t y contrapeso central de 36 t

Tabla de carga [t] con pluma principal 50 m

Radio [m]	Longitud de plumín 7 m
7.9	50.6
9	49.9
11	47.8
16	43.1
24	33.3
28	26.8
32	22.0
36	18.4
40	15.5
44	13.1
50	10.3

Contrapeso trasero de 82.3 t y contrapeso central de 36 t

Tabla de carga [t] con pluma principal 65 m

Radio [m]	Longitud de plumín 7 m
8.4	39.1
10	38.4
14	34.4
22	28.8
30	23.1
38	16.1
46	11.4
50	9.6
55	7.8
60	6.2
65	4.9

Contrapeso trasero de 82.3 t y contrapeso central de 36 t

Tabla de carga [t] con pluma principal 80 m

Radio [m]	Longitud de plumín 7 m
9	26.4
16	23.9
26	19.3
36	15.9
44	11.3
48	9.5
50	8.7
55	6.8
60	5.3
65	4.0
70	2.9

Contrapeso trasero de 82.3 t y contrapeso central de 36 t

TLT 13147978. Estas tablas de cargas sirven únicamente como información. Para trabajos de elevación consultar las tablas de cargas de la cabina o el manual. De lo contrario, lo recomendamos que planifique su trabajo de elevación con Crane Planner 2.0.



www.liebherr.com/CranePlanner

 **Crane Planner 2.0**



Descarguen la ficha técnica



Por favor contáctenos.

Liebherr-Werk Nenzing GmbH · Dr. Hans Liebherr Str. 1 · 6710 Nenzing, Austria
Phone +43 50809 41-473 · crawler.crane@liebherr.com · www.liebherr.com
facebook.com/LiebherrConstruction