Uncompromising Freshness, Unrivalled Luxury

Discover our freestanding and
fully-integrated appliances.

LIEBHERR

Refrigeration and freezing





Contents

Liebherr Group	4
Quality	5
Freshness technology	6
BioFresh Professional with HydroBreeze	8
BioFresh Professional with Fish & Seafood safe	10
Product responsibility	12
Freestanding appliances	14
Series	16
Unique features	18
Appliances specifications	100
Fully integrated appliances	28
Series	30
Unique features	32
Cooling and freezing: an amazing duo	34
Appliances specifications	105
Wine cabinets	58
Qualities that surpass even a wine cellar	60
Unique features	62
Appliances specifications	114
Liebherr Barrique	82
Unique features	84
Appliances specifications	120
Design and Lifestyle	94
Unique features	96
Appliances specifications	122

German Engineering – then, as now

We prioritise uncompromising quality – down to the tiniest screw. And we have done so from the very start. We have been manufacturing high-quality refrigerators and freezers and selling them worldwide since 1954. However, at heart we are still a family business with deep roots in Germany. It is here that we continue to develop all our products just as before. German engineering – out of loyalty to our founder and with the knowledge built up by generations of engineers.



“My life has led me to consider that, with a strong will to do good work and fulfill different customer requirements to the best of your ability, you can also achieve goals that at first seem almost unimaginable. Don’t allow yourself to be disheartened by set-backs, having faith can move mountains”.

Dr.-Ing. h.c. Hans Liebherr (1915 – 1993)



In the 1960s, the L 319 was the “traveling showcase” for Liebherr domestic appliances. The specially converted bus was on the road in Germany until 1968, advertising modern refrigerators and freezers from Upper Swabia.

Even the smallest detail deserves the utmost attention.

You can experience our quality standards in the smallest of details. For example, before a door hinge is approved by us, it must pass through at least 100,000 opening cycles. This corresponds to a usage period of more than 15 years. We also test all other functional parts to ensure that they can last just as long.

Built to last

And if, contrary to expectations, a small detail no longer meets your requirements, you or our premium service partners can usually correct it quickly. Because all our appliances are extremely repair-friendly. We keep all essential spare parts in stock for well over 10 years. This practice is not just sustainable, it also saves you money on minor repairs or the purchase of a new appliance.



EasyFresh for fruit and vegetables from the Pure series upwards.

We don't just say it. We also guarantee it.

During manufacturing we inspect all components of our refrigerators with great care and test them far more rigorously than required by law – and we do this for the last time just before they are packaged. It is only then that our appliances can relax a little. All of our manufacturing sites are certified in accordance with the international standards for quality ISO 9001, energy management ISO 50001 and environmental management ISO 14001. Therefore, nothing could be easier for us than to guarantee for at least two years that our products are free of material and manufacturing faults and are particularly easy to install.

In short: one thing is certain – you will be able to enjoy your Liebherr for a long time.



Magnetic door gasket ensures safe closing.

Uncompromising freshness

You don't compromise when you're shopping. You look for natural ingredients, the best quality and maximum freshness. Of course, anyone who values good food wants to keep it fresh for as long as possible. That is precisely why we have developed innovative freshness technologies and improve them year after year, so your food still tastes fresh after some time in the refrigerator.



EasyFresh – ideal for fruit and vegetables

Unpackaged fruit and vegetables feel right at home here. Stored at the same temperature as the fridge compartment and sealed airtight in the safe, lettuce, for example, is still crisp and fresh after 7 days.



BioFresh – our all-rounder

The reliable BioFresh technology stores groceries at a temperature just above 0 °C, much cooler than in the rest of the appliance. With the ideal humidity, fruit and vegetables stay fresh even longer in the airtight Fruit & Vegetable safe. Meat, fish and dairy products can enjoy ideal conditions in the Meat & Dairy safe.



BioFresh Professional with HydroBreeze

A cold mist that covers fruit and vegetables like a protective balm. It ensures crisp freshness and improves structure – the special wow effect for fruit and vegetables in the BioFresh Professional safe.



BioFresh Professional with Fish & Seafood safe.

Particularly delicate foods like fish and seafood are best stored in icy temperatures and at low humidity. The constant temperature of -2 °C in the Fish & Seafood safe is therefore ideal to keep these items tasting fresh for longer.



DuoCooling – no drying out

The two completely separate refrigeration circuits ensure that there is no air exchange between the fridge and freezer compartments. Groceries do not dry out nor spread odour.



NoFrost – no more defrosting

The automatic defrosting function guarantees that frozen foods remain fresh. There is no longer a need to store frozen food temporarily during manual defrosting. The constant optimal freezing remains the same without interruptions.

Cool and misty. Ideal weather for your vegetables.

Our HydroBreeze feature exemplifies our highest standard of freshness. A cold mist covers fruit and vegetables like a protective balm in the BioFresh Professional safe. The mist ensures crisp freshness, improves structure and keeps produce with fine leaves fresh for longer. It also creates an optical wow effect in the BioFresh Professional safe.



Nature's freshness secret

The Salinas valley in California is known as the salad bowl of the USA. And that is because of the particularly favourable climatic conditions. Its proximity to the cool waters of the Pacific means a fine, moist mist covers the valley and its fields in summer. This prevents the crops growing here from drying out. It is precisely this idea which inspired our BioFresh Professional with HydroBreeze.



Every time the door is opened, a fresh, cold mist is generated.

Hydro
Breeze

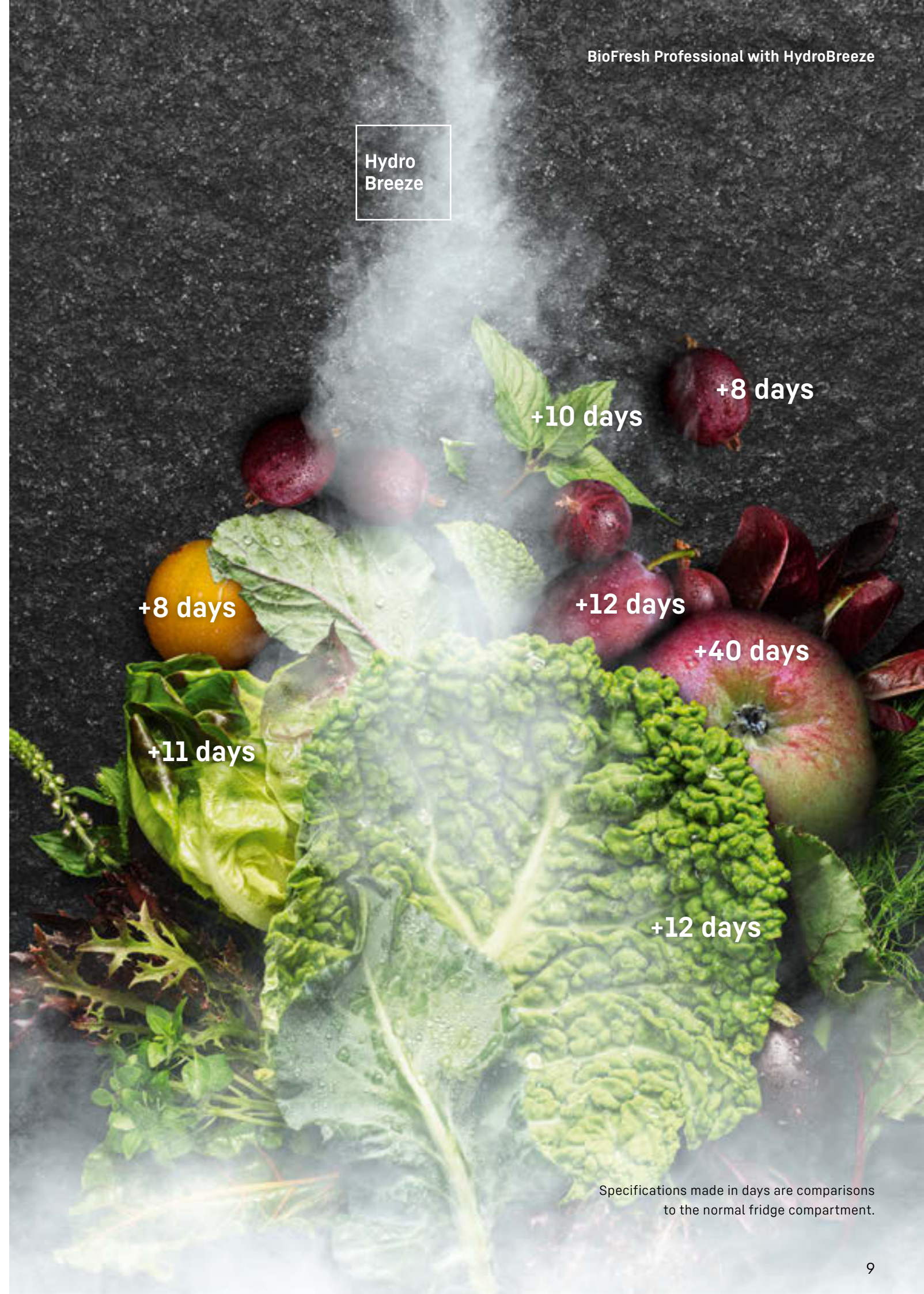

Specifications made in days are comparisons to the normal fridge compartment.

Relish the freshness of the sea.

To keep fish and seafood tasting as fresh as at the market stall, even after a few days, you need a fridge compartment which maintains their freshness; such as our Fish & Seafood safe. Fish and seafood can be stored here at $-2\text{ }^{\circ}\text{C}$ and low humidity. Ideal conditions to enjoy that freshly caught flavour for much longer.



Specifications made in days are comparisons to the normal fridge compartment.



Flexible use
The surface of the BioFresh Professional safe can be adjusted to individual requirements. The $-2\text{ }^{\circ}\text{C}$ can be partially or even completely adjusted to a temperature zone at just above $0\text{ }^{\circ}\text{C}$. This is the optimal storage environment for meat and dairy products. We have illustrated these four options below:

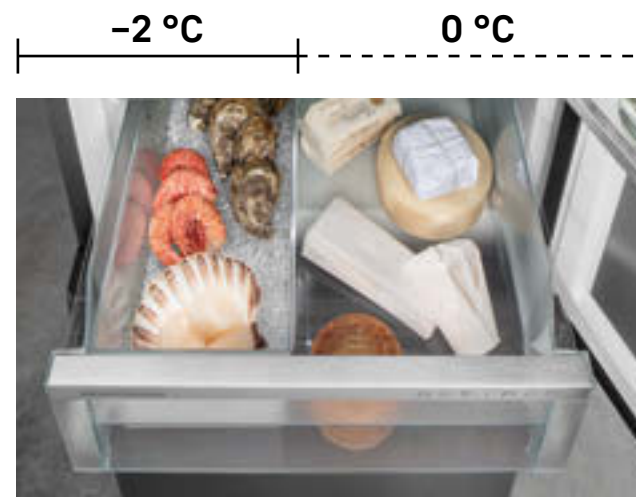
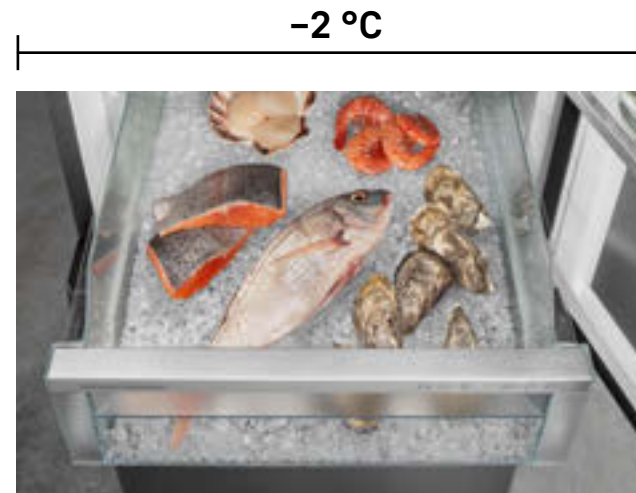

Thinking beyond just today

We are fastidious in adopting a holistic approach to sustainability when designing our appliances. The key elements of this are the durability of our appliances, maximum energy efficiency and reducing food waste. Why do we do all this? Because a holistic approach is needed to protect both people and the environment in equal measure.

Reducing food waste

Everyone who stores food in the optimum climate plays a big part in reducing unnecessary food waste. Our appliances make this possible – with a combination of innovative features:

First: Our freshness technologies. DuoCooling in our fridge-freezers, for example, prevents your groceries from drying out faster than need be. Innovative freshness technologies such as BioFresh ensure ideal storage conditions that significantly extend product life and freshness. So there's no need to throw food away before its time, and you don't need to go shopping so often. And the largest zero-degree compartments on the market provide enough space for extra-large amounts of groceries.

Second: Our SmartDevice app also helps you to store your food properly, giving your food a longer shelf life so you can enjoy it for even longer.

Third: Our appliances are intelligent and let you know if ideal storage for your groceries is at risk. For example, by using a door alarm to tell you if the appliance door is still open.

Thoroughly thought out: a powerful, complete package

Our fridges are real all-rounders. Along with their low power consumption, they also have impressively low noise levels, plenty of space for groceries, a long service life and reliable power reserves for when it really matters. We take account of a great many factors during the development stage and can offer an ideally balanced appliance. Or to put it another way: all good things come in fours.

Energy consumption

Our refrigerators and freezers occupy top positions in the efficiency rankings. In this way, they protect the precious resources of our environment and – thanks to low electricity costs – your wallet too.

Cooling volume

We have the ideal appliance for all family sizes, lifestyles and niche heights. We make sure that we do not waste a single litre of capacity in the extra-large drawers – right down to the smallest detail, for example with the lighting solutions that have been integrated in the housing to save space.

Noise level

The boundaries between the kitchen and living areas are becoming ever more blurred in modern households. This underlines the importance of particularly quiet appliances. Our range of refrigerators and freezers therefore offers a wide selection of extremely quiet appliances. In some cases, it even reaches the ultra-quiet noise level of 32 db.

Cooling performance

Intelligent sensor technology constantly adapts the cooling performance to current use, making our refrigerators and freezers very energy-efficient and economical in everyday use. At the same time they also have plenty of power in reserve, for example to cool down a large quantity of groceries after the weekly shop.

Freestanding appliances



For a clear overview.
Even before you
open the fridge.



StainlessSteel dry rear wall



EasyTwist Ice

◆ Plus series

The Plus series builds on our Pure series and has many impressive additional details. Above all, Plus means a plus in comfort. The appliances not only provide first-class refrigeration and freezing, they are also just that little bit smarter. They help make operation a little easier.

○ Prime series

With the Prime series things get much more classy. It makes an unmistakable mark in terms of design and material. Above all, genuine quality materials are used inside the appliances, such as stainless steel. But special lighting solutions also make the appliances in this series particularly appealing.

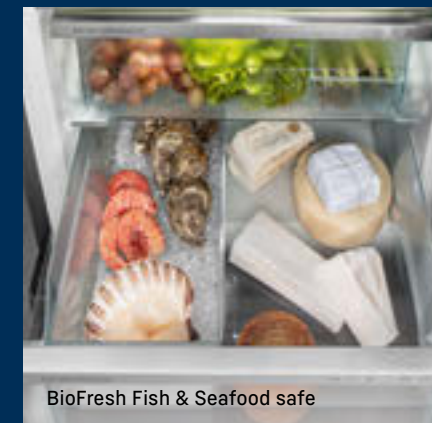

BioFresh Fish & Seafood safe



Touch & Swipe

◆ Plus ○ Prime



LightTower



SoftSystem

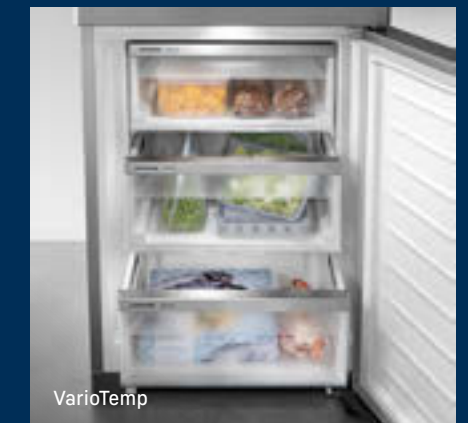

VarioTemp

BioFresh Professional 0°C



-2°C

Fish & Seafood



PowerCooling

Do you want to be sure that the cold is distributed as evenly as possible in your refrigerator? If so, the PowerCooling system is what you need. The fan – as powerful as it is quiet – distributes the cold air efficiently throughout the entire refrigeration compartment.



IceTower

You will never run out of cold drinks at your party. The IceTower, which holds 8 kg of ice cubes, makes sure of that. The ice cube scoop and the pull-out tray on telescopic rails allow easy access to the ice cubes. An extra insert tray means you can also store less ice and make room for frozen food underneath. The adjacent drawer provides storage space for frozen goods.



VarioTemp

VarioTemp means you have plenty of scope when storing food in your fridge freezer. This is because you can also set the accurate temperature in the freezer compartment in a range between -2 °C and +14 °C – and therefore also use this compartment as a further cooling zone. For example, it can be used over the short term for drinks and snacks at parties – or over the long term as a cellar compartment for storing potatoes.



Fish & Seafood safe

Love fish? Your Liebherr keeps fish fresh! The Fish & Seafood safe stores fish and seafood at the optimum temperature of -2 °C; as professionally as your fishmonger. Adjust the size of the -2 °C zone as much as you want – and store the remaining meat and dairy products at the optimum 0 °C. An LED display indicates that the -2 °C zone is currently active.

Your exclusive gourmet market

The XRCsdh 5266 is another spacious option that widens the range of freestanding side-by-side solutions: a full-size refrigerator paired with a combined fridge-freezer.

With a total of five BioFresh safes and a drawerless full BioFresh zone above the freezer, the two appliances offer plenty of space to keep your entire week's groceries fresh. The special Fruit & Vegetable and Meat & Dairy safes provide the ideal climate with temperatures close to 0 °C. Even delicate fish and seafood have a prolonged shelf life in their dedicated BioFresh safe with a constant temperature around -2 °C.

In addition to comfort features like the IceMaker and variable temperature control, the freezer also has NoFrost to protect it from icing up.



Bio Fresh Professional	Fish & Seafood	Bio Fresh	No Frost	Super Frost	Super Cool	Vario Temp
Soft System	Soft-Telescopic Rails	Touch & Swipe-Display	Glass & Steel Interior	Light Tower	Ice Maker	Smart Device ready

For the cool gastronomist

The BluPerformance XRFsdh 5265 doesn't just unite a fridge and a freezer into a unique side-by-side solution, but also combines modern aesthetics with pioneering functionality.

For example, the spacious refrigerator has variable BioFresh safes that ensure your food stays fresh for a very long time at temperatures just above 0 °C. NoFrost saves you costly and time-consuming freezer defrosting. And with the extra large SpaceBox you can store big products like layered cakes or even a whole turkey for your next party without removing any drawers or shelves.



- | | | | | | | | |
|------------------------|----------------|-------------|-------------|------------|-------------|-----------------------|-----------------------|
| Bio Fresh Professional | Fish & Seafood | No Frost | Super Frost | Super Cool | Soft System | Soft-Telescopic Rails | Touch & Swipe-Display |
| Glass & Steel Interior | Space Box | Vario Space | Easy Open | LED | Light Tower | Ice Tower | Smart Device ready |



The epicurean's dream kitchen

The XCCsdh 5250 side-by-side combination has everything that distinguishes premium refrigerators and freezers: top-quality design and technology down to the finest detail. And all that twice over.

The easily accessible refrigerators in the top part each have a spacious EasyFresh safe, where fruit and vegetables stay as fresh and vitamin-rich as if they were straight from the market. NoFrost technology in the two freezer units below ensures that your food is protected from icing up.

With two separate refrigeration circuits, DuoCooling prevents air exchange between the refrigerator and freezer compartments, thus protecting your food from transferred odours and drying out.



Easy Fresh

Duo Cooling

No Frost

Super Cool

Super Frost

Vario Temp



Soft System

Touch & Swipe-Display

Vario Space

Glass & Steel Interior

Light Tower

Smart Device ready

XCCsdh 5250 ◊ Prime series

Introducing a new dimension of freshness

With the new 75 cm wide CBNsdh 7653 Fridge-Freezer Combination from the Prime series, we are adding another option to our portfolio. And a few more liters capacity for your food supplies. Despite its generous size, the elegant SmartSteel appliance fits seamlessly into the kitchen décor.

The Refrigerator in the upper section has height-adjustable shelves and a BioFresh compartment that preserves the natural freshness of fruits, salads and vegetables. All clearly illuminated by the innovative LightTower on both sides of the interior. Underneath is the Freezer with the EasyTwist IceMaker and patented NoFrost technology, which eliminates the need for tedious defrosting.

Two separate refrigeration circuits prevent air exchange between the Refrigerator and Freezer compartments. As a result, food does not dry out or absorb unpleasant odors.

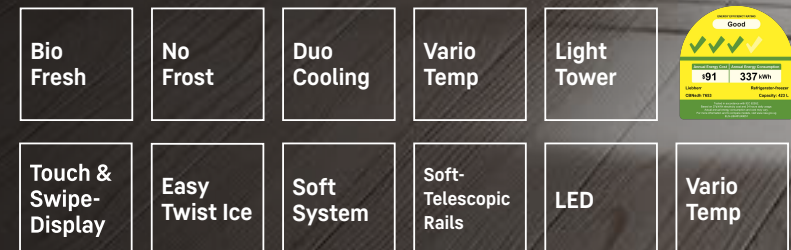

Sweet taste of freshness

The BluPerformance SCNsdh 5253 fridge-freezer is a reliable companion for everyday use. The integrated appliance is compact in size, but all the more versatile in the options it offers you.

The refrigerator compartment in the upper part has variable height-adjustable shelves, clearly illuminated by the innovative LightTower. An EasyFresh safe ensures that unpackaged foods such as fruit, salads or vegetables retain their natural freshness. And the patented NoFrost technology permanently eliminates the chore of defrosting the freezer.

The two parts of the appliance are cooled by completely separate refrigeration circuits. This technology known as DuoCooling prevents air exchange between the refrigerator and freezer compartments, so your food won't dry out or absorb any unwanted odours.



SCNsdh 5253 ○ Prime series



- | | | | | | |
|-------------|-----------------------|-------------|------------------------|-------------|--------------------|
| Easy Fresh | Duo Cooling | No Frost | Super Cool | Super Frost | Vario Temp |
| Soft System | Touch & Swipe-Display | Vario Space | Glass & Steel Interior | Light Tower | Smart Device ready |

Fully integrated appliances



For a clear overview.
Even before you
open the fridge.

○ Pure ◇ Plus △ Peak

○ Pure series

The Pure series is our basic class. Simple, clear and nicely equipped for all essential needs. The Pure series has been reduced to the essentials. But full to the brim with the highest level of Liebherr quality.

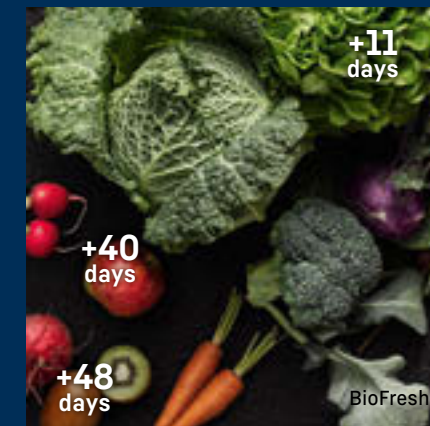

◇ Plus series

The Plus series builds on our Pure series and has many impressive additional details. Above all, plus means a plus in comfort. The appliances not only provide first-class refrigerating and freezing, they are also just that little bit smarter. They help make much of the handling a little easier.

△ Peak series

The Peak series sits at the top of our series. Here the best is combined with the best. There is no compromise. Innovative Liebherr technology meets high-end design and comfort solutions that are simply first in its class. Appliances in this series are for those who want everything.





**Bio
Fresh
Professional**



PowerCooling

Do you want to be sure that the cold is distributed as evenly as possible in your refrigerator? If so, the PowerCooling system is what you need. The fan – as powerful as it is quiet – distributes the cold air efficiently throughout the entire refrigeration compartment.



IceMaker

Are there any ice cubes left? An IceMaker means you never have to ask. With the IceMaker with fixed water connection, the water comes directly from the tap. The MaxIce function allows you to produce up to 1.5 kg of ice cubes a day. The ice cube separator helps to divide the drawer into any size you want – for example, ice cubes on the left, ice cream on the right – or just for ice cubes.



Touch & Swipe Display

Control of your Liebherr at your fingertips: thanks to the Touch & Swipe display, you can operate your refrigerator intuitively and with ease. Simply select functions such as SuperCool on the colour display by tapping and swiping. The temperature is controlled just as easily. And, what if you are not actively using the display? Well, it then shows you the actual temperature.



SuperSilent

Shhh – listen carefully. Your Liebherr is so quiet that you have to strain your ears to hear it. How is this achieved? All refrigeration components such as compressors, valves, fans and evaporators are optimised and nicely adapted to one another. This means you only hear what you want to hear in your kitchen.

Cooling and freezing: an amazing duo



ICNh 5173 Δ Peak series | ICBNh 5173 Δ Peak series

Or trio?

There are endless possibilities for combining our refrigerators and freezers depending on space and requirements. With our side-by-side solutions, we ensure that they also fit seamlessly next to each other as a built-in combination.



SIFNh 5188 Δ Peak series | EWTdf 3553 Vinidor | IRBPh 5170 Δ Peak series

Or quartet? Freshness is stackable!

Even if it doesn't look like it, our refrigerators are extremely flexible because they can be freely combined and stacked with the side-by-side concept. Refrigerators, freezers, wine appliances or full-capacity BioFresh can be combined to create a completely individual freshness centre consisting of several individual elements and cooling zones. Ask your Liebherr dealer for advice on an individual solution for your fitted kitchen.



SIFNh 5188 Δ Peak series | EWTdf 3553 Vinidor
IRBh 5170 Δ Peak series | IRBPh 5170 Δ Peak series

The ultimate indulgence

In the IRBh 5170 refrigerator, cold mist from HydroBreeze covers fruit and vegetable like a protective balm in the BioFresh Professional safe. Adjust the temperature down to $-2\text{ }^{\circ}\text{C}$ to create a low humidity environment for retaining the freshness of your catch of the day in the Fish & Seafood safe.

For parties and gatherings, IceTower in the SIFNh 5188 freezer produces up to 1.2 kg of ice cubes daily whereas VarioSpace provides added flexibility for large cakes.

The insulated triple glazed door of our EWTdf 3553 dual-zone wine cellar protects your finest collection from UV exposure. Handcrafted beechwood shelves on telescopic rails reduces vibrations, allowing wines to develop in peace.



Bio Fresh Professional	Hydro Breeze	Fish & Seafood	No Frost	Super Frost	Super Cool	Vario Space	Wine	2 Zones	Humidity Select	Fresh Air
Steel Interior	Presentation Board	Soft System	LED	Telescopic Rails	Soft-Telescopic Rails	Touch & Swipe-Display	Glass & Steel Interior	Light Tower	Ice Tower	Smart Device ready



Unrivalled haven of luxury

The IRBPh 5170 fits seamlessly into your kitchen cabinet. This premium refrigerator reveals its qualities as soon as you look the interior, which is perfectly beautifully by the innovative LightTower system.

OpenStage drawers of different heights not only offer ample space for food and a secure hold for drinks, but also a full view of them. The smooth-running telescopic rails make it easy to put things in and take them out.

Below them, the BioFresh safes live up to their name. Special compartments for fruit and vegetables as well as for meat and dairy products ensure optimum conditions with temperatures near 0 °C to preserve the natural freshness of the food.

And with the intuitive Touch & Swipe Display the fridge's features and settings, like the SuperCool mode, and all information about your appliance are just one swipe away.



reddot winner 2022



IRBPh 5170 Δ Peak series



Bio Fresh

Super Cool

Soft System

Touch & Swipe-Display

Open Stage

Glass & Steel Interior

Light Tower

Smart Device ready

See food in a new light.

Our most premium range of new Fully Integrated appliances: Meet the ICNh 5173 and ICBNh 5173.

One highlight exclusive to the ICBNh 5173 is the brand new HydroBreeze which produces a fresh, cold mist that coats fruits and vegetables to ensure their crisp freshness. And the IceMaker provides plenty of ice cubes for refreshing drinks all day long.

The ICNh 5173 Fridge-Freezer with EasyFresh safes offers plenty of space for your favourite food and ingredients.

Both models in this combination are equipped with a high-resolution Touch & Swipe display. Their exquisite interior craftsmanship of glass and stainless steel illuminated by our new LightTower makes every peek inside a visual experience.



ICNh 5173 Δ Peak series | ICBNh 5173 Δ Peak series



Bio Fresh Professional	Hydro Breeze	Easy Fresh	Duo Cooling	No Frost	Super Silent
Soft System	Glass & Steel Interior	Light Tower	LED	Ice Maker	Touch & Swipe-Display

Built-in luxury

ICNh 5123 and ICNh 5133: models from our new Fully Integrated selection.

This side-by-side fridge-freezer combination offers plenty of storage space with EasyFresh safes that allow different humidity modes for a wide array of fresh groceries.

NoFrost technology ensures a permanently frost-free freezer compartment. Thanks to Liebherr's door-on-door technology, our fully integrated appliances fit seamlessly into spacious kitchens and integrate seamlessly into your existing cabinetry.

Being SuperSilent models due to the special design and low-noise components, this combination is extremely quiet. Thanks to our SoftSystem the appliance doors always close gently even when fully loaded.



- Easy Fresh
- Duo Cooling
- No Frost
- Super Cool
- Super Frost
- Soft System
- Touch Display
- Vario Space
- Ice Maker Water tank
- Smart Device ready



ICNh 5123 ◊ Plus series | ICNh 5133 ◊ Plus series

Wonderfully fresh, always

The sophisticated ICNh 5103 fits seamlessly into your kitchen: Elegant, slim, full of innovative features.

In the EasyFresh safe, you can store fresh fruits and vegetables in the best possible way. With its airtight seal, no moisture can escape and groceries stay as fresh and appetising as at the market stand.

Thanks to DuoCooling technology, this built-in fridge-freezer has two completely separate cooling circuits. This prevents any air exchange between the refrigerator and freezer compartments, keeping your food from drying out and eliminating odour transfers. Want to keep your homemade pizza or cake fresh? The ICNh 5103 even has room for a whole baking tray!



Easy
Fresh

Duo
Cooling

No
Frost

Super
Silent

LED



ICNh 5103 ○ Pure series

Fresh on the inside, sleek on the outside

Behold the ECBN 8872 Fridge-Freezer with its magnificent French doors. They open up unlimited possibilities for storing large quantities of food in ideal conditions.

Premium GlassLine shelves and door racks with brushed stainless steel rails provide a clean overview. And two BioFresh safes preserve the natural freshness of fruit, salads and vegetables.

Below, but also technically on top, are two smooth-running NoFrost freezer compartments with a powerful plumb-in IceMaker that provides an inexhaustible supply of crystal-clear ice cubes. Our innovative DuoCooling system eliminates any odour transfers between the Fridge and Freezer compartments.

ECBN 8872



Bio
Fresh

Duo
Cooling

Ice
Maker

Super
Frost

No
Frost

Super
Cool

More space for fresh ideas

Enjoying the built-in ECBN 7870 Fridge-Freezer starts with the 75 cm wide door opening effortlessly thanks to its SoftSystem. Beautifully illuminated by LED light towers on both sides of the interior, the GlassLine shelves and door racks with brushed stainless steel rails are a delight to the eye.

Two BioFresh safes not only provide plenty of space for fresh food, but also the ideal conditions to keep it that way. And in the summer heat, you'll be happy to know that the IceMaker with the enlarged TwistTray dispenses 12 ice cubes at a time. Fun fact: Our innovative NoFrost technology saves you the hassle of defrosting forever.



Bio
Fresh

Duo
Cooling

Ice
Maker

Super
Frost

No
Frost

Super
Cool



ECBN 7870

The smooth operator

A unique pull-out model, the SUIKo 1550 Undercounter Fridge serves as a great option for kitchen islands.

Mounted on soft telescopic rails to enhance user-friendliness and convenience, it comes with a practical bottle shelf and a large fruit and vegetable drawer. The drawer can also be divided into two equal-sized compartments, with further storage space underneath.

SuperCool function quickly reduces temperature which is ideal for rapidly cooling down freshly stored food. The innovative LED light and special satin finish of the light cover produces a pleasant lighting atmosphere.

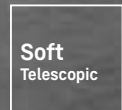

SUIKo 1550

Convenience at your fingertips

Our space-saving undercounter appliances are the practical choice for compact living spaces. The SUIK 1510 Undercounter Fridge is great for fresh produce with height-adjustable glass shelves to ensure maximise storage flexibility.

The superb companion for this undercounter fridge is the SUIG 1514 Undercounter Freezer with SmartFrost technology, allowing food to freeze faster and reducing ice build-up to make defrosting simpler and quicker.

Both models are equipped with innovative SoftSystem technology which ensures that the appliance door closes gently and automatically from an opening angle of approximately 30°. No ventilation grill is needed in your worktop as airflow enters and exits from the front of both undercounter models.



Soft
System

Smart
Frost



SUIG 1514 | SUIK 1510

Wine cabinets



Qualities that surpass even a wine cellar.

To preserve what connoisseurs treasure, Liebherr wine cabinets have some exceptional features. They not only match wine cellars in terms of the five essentials of storage, but surpass them thanks to our engineering expertise.

We take care of every detail.



Constant temperatures protect the character of the wine.



Temp Protect Plus

Liebherr wine cabinets have TempProtect Plus for double temperature protection.

The right humidity keeps corks supple to protect the wine.



Humidity Select
Humidity Control

With HumiditySelect or HumidityControl, the humidity in Liebherr wine cabinets can be individually adjusted.

Keeping out ultraviolet light protects the wine from ageing badly.



UV Protect
UV Protect Plus

Liebherr glass door models have unique double or even triple anti-ultraviolet glazing.

Keeping out foreign odours stops them from spoiling the taste of the wine.



Fresh Air

The FreshAir activated char coal filter in a Liebherr wine cabinets neutralises foreign odours.

Preventing vibrations allows the wine to mature undisturbed.



Vibrate Safe

Liebherr wine cabinets have a fully vibration-insulated cooling system.



For a protected view inside

To minimise the effect of harmful ultraviolet light, all glass doors in Liebherr wine cabinets are made of special UV-resistant insulated glass. On models with UV-Protect, the protection comes from a special two-pane construction with a tinted pane on the inside and a metallised Low-E pane on the outside.



Triple protection

For long-term storage, our wine storage cabinets with UVProtect Plus offer unprecedented and unique protection against ultraviolet light. Three protective layers consisting of tinted glass and a double layer of vacuum-deposited metal (Low-E).

Safe light

We use high-quality LEDs to ensure even lighting of the interior. That's because their spectrum does not contain any ultraviolet light. And because the LEDs generate very little heat, wines can be lit for lengthy periods without affecting their temperature.



Presented in the best light

The vertically positioned LightColumn evenly illuminates the interior of your Liebherr wine cabinets when the door is open. In addition, the dimmable presentation lighting artfully shows off your wines even when the door is closed.



Providing a clear view

Solid door models have a space-saving LED light recessed into the ceiling.

Each wine within its own comfort zone

If it weren't for its attractive appearance, you'd hardly notice the super-silent WPgbh 7473 from the Vinidor Selection Series.

This Multi-Temperature wine cabinet is a real statement piece that showcases your taste in wine and design at the same time. With three temperature zones that can be adjusted separately to the degree from +5 °C to +20 °C, it allows you to serve different wines at their ideal drinking temperature.

Behind the UV-resistant black glass door, your treasures are safely stored in controlled humidity and beautifully displayed on hand-crafted wooden shelves. Easy-to-change activated charcoal filters ensure that the bouquet of the wines is not affected by any foreign odours.

eDoor Lock	Light Tower	3 Zones	Glass Door	Recess Grip	Touch & Swipe-Display	Flex Fit
Soft Telescopic	Soft System	Smart Device ready	Humidity Select	Temp Protect Plus	Fresh Air	

Take wine tempering to the next level. On every shelf.

A new wine cabinet is the perfect occasion to have guests over. Especially when it's as prestigious as the WPbs 5262 from the Vinidor Series.

Its sleek BlackSteel finish alone makes it an eye-catcher at any party. The glass door provides a clear view of the well-illuminated wines displayed on wooden shelves. Up to 155 red and white wines can be kept at the perfect drinking temperature between +5 °C and +20 °C in two separately adjustable temperature zones.

Behind the scenes, quality enhancing features such as HumiditySelect, FreshAir activated charcoal filter, VibrateSafe and TempProtect Plus work their magic. As a result, the WPbs 5262 takes wine storage to a whole new level – from bottom to top shelf.



Fresh Air	Easy Fill	Self Closing Door	UV Protect Plus	Vibrate Safe	Soft System	Temp Protect Plus
eDoor Lock	Smart Device ready	Humidity Select	2 Zones	LED	Steel Interior	Touch & Swipe-Display

WPbs 5262



Perfectly presented, exquisitely served

Present your wines in the best light while storing them at the ideal temperature in the WPsd 5262 from the Vinidor series.

This stainless steel wine cabinet, with its large UV-resistant glass door, is an impressive showpiece that simultaneously reflects your passion for wine and style. Display your wines at their best on the height-adjustable wooden shelves.

Thanks to the two independent temperature zones, which you can set to the exact degree from +5 °C to +20 °C, your wine is always at the ideal perfect serving temperature. And thanks to the ideal humidity and the activated charcoal filter, you don't have to worry about unwanted changes in the flavour of your fine wines.

2 Zones	Temp Protect Plus	Humidity Select	Fresh Air	UV Protect Plus	Soft System
Smart Device ready	Vibrate Safe	Steel Interior	LED	Touch & Swipe-Display	eDoor Lock

WPsd 5262

Enjoy your wine even before you serve it.

With the medium-sized WPsd 4652 from the Vinidor series, the pleasure of wine begins long before the first sip. Looking through the UV-resistant glass door is enough to get excited.

Inside the sleek stainless steel Wine Presentation Cabinet, up to 107 bottles are stored in ideal climatic conditions on vibration-free wooden shelves. They are not only ready to hand, but also ready to serve. Two separate zones, each adjustable between +5 °C and +20 °C, ensure that red and white wines are always at the ideal drinking temperature.

In addition to state-of-the-art features such as LED lighting, Touch Display, FreshAir activated charcoal filter and TempProtect Plus, the WPsd 4652 Wine Cabinet has another unique highlight built in: the anticipation of delicious wines.

Humidity Control	UV Protect Plus	Easy Fill	Fresh Air	Touch Display
Smart Device ready	Door Lock	LED	Self Closing Door	Temp Protect Plus

WPsd 4652



Raise a glass to ideal wine storage!

As your passion for wine grows, so does your collection. With the WSbl 7731 wine storage cabinet from the GrandCru Selection Series, you have plenty of space for it. Its generous dimensions allow neck-to-neck storage of 324 Bordeaux bottles.

TempProtect Plus uses two sensors to ensure that the wines mature at a constant temperature between +10 °C and +12 °C until they reach their full potential. And because they must not be disturbed during this process, the bottles are stored on vibration-absorbing wooden shelves. Extremely quiet compressors do the rest.

As every wine connoisseur knows, even a small detail like the cork is highly important for the quality of the wine. That's why the WSbl 7731 has an activated charcoal filter for better air quality, while HumidityControl keeps the humidity at a constant ideal level between 50% and 80% RH.

And when the time comes for a special bottle from the Liebherr cellar, please raise a glass to you and your taste!

Humidity Control	Easy Fill	Fresh Air	Touch Display	LED
Smart Device ready	Door Lock	Steel Interior	Self Closing Door	Temp Protect Plus

WSbl 7731



For wines, it is heaven

There is no need to hide your precious wines in the cellar anymore. On the contrary, the WPbli 5231 wine storage cabinet from the GrandCru Selection Series deserves all the attention it gets.

Firstly, for its iconic design, combining a black steel body and a black framed glass door on the outside with handcrafted wooden shelves and a sleek metal rear panel on the inside.

Secondly, for the dimmable presentation lighting that ideal showcases your wine collection even when the door is closed.

And finally, for FreshAir activated charcoal filter, UVProtect Plus, HumidityControl, VibrateSafe, TempProtect Plus and many other outstanding features that ensure optimal wine storage and maturation – right in your living room, if you like.

Humidity Control	UV Protect Plus	Easy Fill	Fresh Air	Touch Display	Smart Device
Light Column	Door Lock	LED	Self Closing Door	Temp Protect Plus	

WPbli 5231



A cabinet full of treasures

The UWKes 1752 Undercounter wine cabinet is ideal for storing wines for extended periods, allowing them to mature flawlessly. Its LED lighting ensures uniform illumination of the interior without any damages caused by UV light.

If you like reds, whites, as well as champagne, pair the UWKes 1752 with our dual-temperature zone model UWTes 1672. Now enjoy your favourite bottles all stored at their desired temperatures between +5 °C to +20 °C!

LED

Telescopic
Rails

UWTes 1672 | UWKes 1752

Savour the difference with a Liebherr.

Like a shaken bottle of champagne, the EWTdf 3553 dual-zone wine cellar is absolutely exploding and overflowing with innovative features.

Its touchscreen controls are integrated into the insulation layer between the temperature zones, allowing you to set two different temperatures within the unit and simultaneously store red and white wines, each at its optimum drinking temperature. An insulated glass door protects your favourite collection from UV exposure while handcrafted beechwood shelves on telescopic rails reduces vibrations, allowing wines to develop in peace.

Seamlessly fit this built-in model into your customised kitchen décor or turn it into a stainless steel masterpiece with our selection of accessories.



EWTdf 3553

- 2 Zones
- Humidity Select
- Fresh Air
- Soft System
- Telescopic Rails
- Presentation Board
- LED
- Steel Interior



Classic and sleek, fits anywhere

Take advantage of the design flexibility of Liebherr's fully integrated WKEes 553 Wine Cabinet – Place this sleek, modular model anywhere in your home and proudly display your best wine collection at eye level.

Temperature is adjustable from +5 °C to +20 °C and the LED ceiling light is dimmable to cast a cool glow across the room. The insulated glass door with UV protection and activated charcoal filter protects your wine from light and odour. This compact unit holds up to 18 Bordeaux bottles in an ideal storage environment.

LED

Telescopic
Rails

WKEes 553



Liebherr Barrique



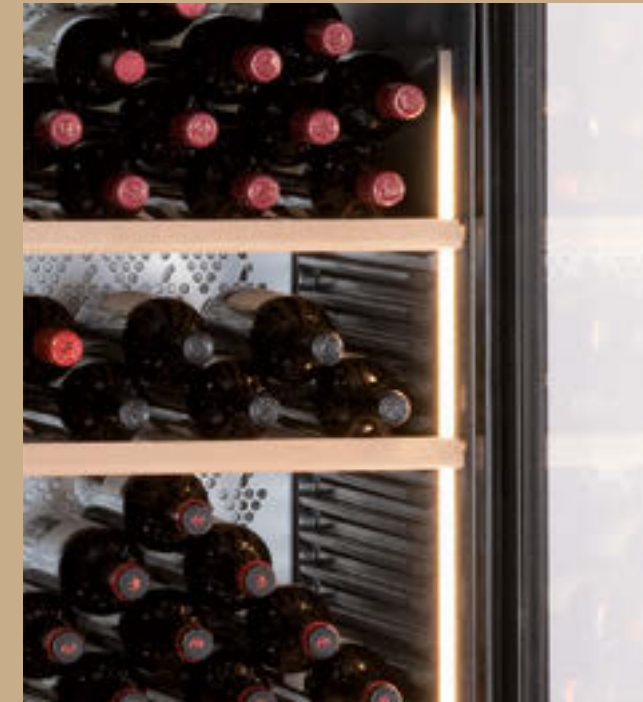

LED lighting

The tinted glass door provides not only a ideal UV protection, but also an optimum glance at wine. The integrated LED lighting ensures a pleasant illumination of the complete interior.



Presentation shelf

The presentation shelf, equipped with wooden angles, is ideal for presenting wine and storing open bottles safely. Up to 6 bottles can be set upright on the flexible shelf. In addition further bottles can be stored lying down either behind or at the side.



Activated charcoal filter

The easy replaceable active charcoal filter purifies the incoming air to obtain an optimum odour-free interior.



Precision electronics

The precise electronic control system is equipped with a digital temperature display. The door and temperature alarm alerts of any irregularities, e.g. when the door is left open. The integrated lock on the front panel prevents unwanted access to the stored bottles.

Clear display for all your favourites

With the capacity to hold 195 Bordeaux bottles, the spacious Liebherr Barrique WKb 4612 Wine Cabinet is ideal for the long-term storage and maturation of wines.

Constant temperature can be set as desired between +5 °C to +20 °C via the intuitive control system with digital temperature display.

Thanks to its coated glass door, wines will always be well-protected from UV radiation. Efficient LED lighting ensures that the interior is illuminated evenly and pleasantly, allowing you to proudly showcase your prized collection.



WKb 4612

LED

Fresh
Air

Wine storage sophistication for your home

The WKb 4611 Wine Cabinet mimics the conditions of an underground wine cellar where its solid door creates a dark, undisturbed environment with zero exposure to UV light and heat fluctuations – ideal for maturing wines.

When humidity level falls below 50%, natural corks begin to shrink, causing oxygen to enter the bottle and damage stored wines. With a humidity range between 50% – 80%, Liebherr wine cabinets guarantee the ideal conditions to preserve the suppleness of wine corks which in turn prevents oxidation.

Your wines are always stored safely on our untreated beech wood shelves while an activated charcoal filter provides optimal air quality.

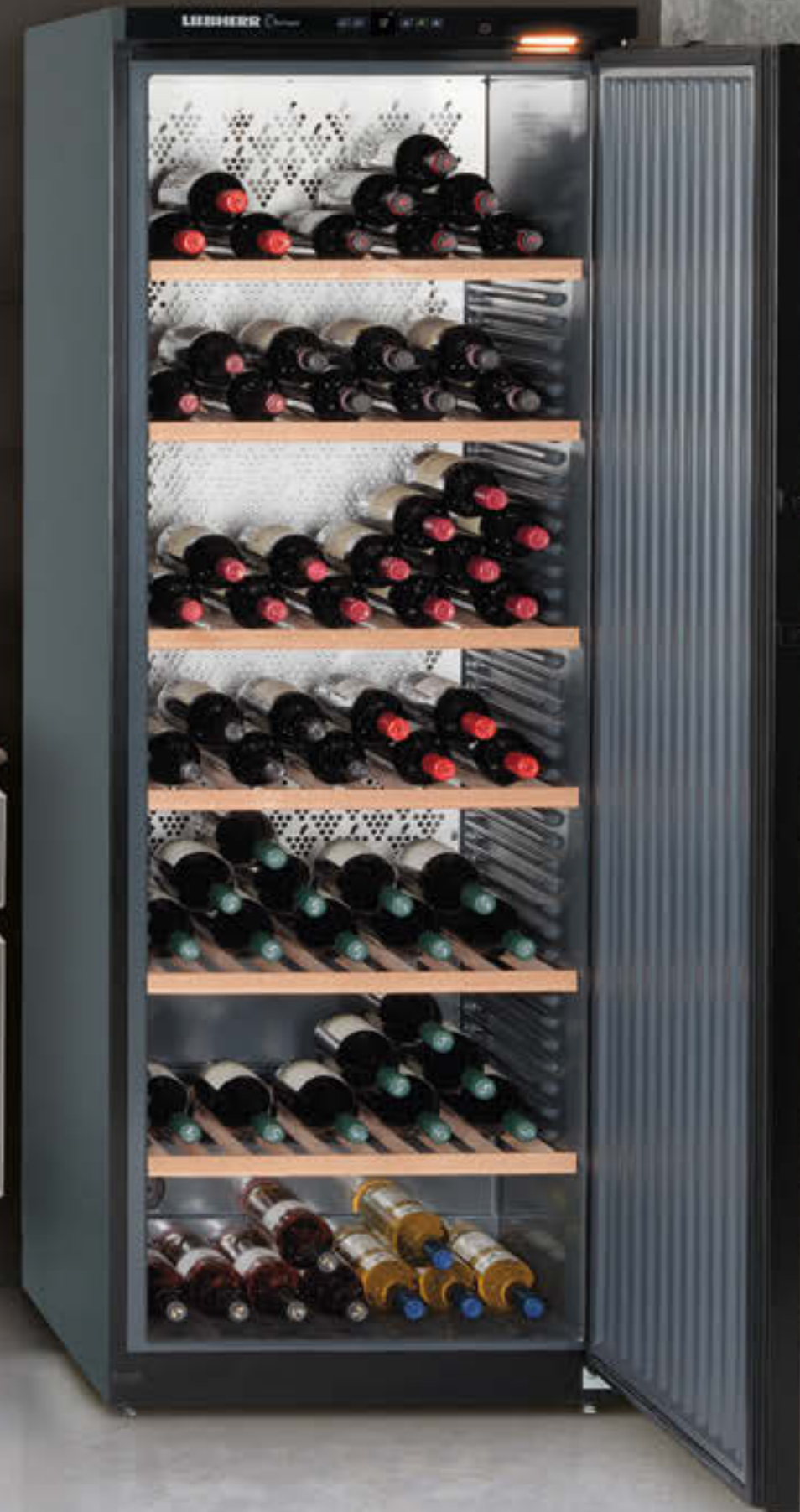

The storage choice for wine aficionados

The Liebherr Barrique WKb 4112 Wine Cabinet features an insulated glass door that provides protection from UV radiation and preserves the quality of wine.

Temperature can be adjusted between +5 °C to +20 °C and is ideal for the long-term storage of fine wines – be it for maturing or storage. Our integrated activated carbon filter absorbs odours from the ambient air and prevents the taste of fine wines from being impaired.



WKb 4112

LED

Fresh Air

Superb conditions for fine wines

Our most compact model from the Liebherr Barrique series, the WKb 1712 Wine Cabinet can store up to 60 Bordeaux bottles. Wines are stored optimally on three untreated, height-adjustable beech wood shelves.

Wines are well protected from UV radiation thanks to a tinted insulated glass door while the activated charcoal filter provides optimum air quality and is easy to replace.

Energy-efficient LED lighting ensures even and pleasant illumination so that your favourite bottles are seen in the best light.



LED

Fresh
Air

WKb 1712

Design and lifestyle





Touch electronic control system

The best wine storage temperature is +8 °C to +12 °C. White wine should ideally be stored below +10 °C and red wine at up to +18 °C. Our electronic control system allows temperature to be set to the exact degree required between +5 °C to +20 °C.



Ideal humidity

The integrated water tray can accommodate one liter of distilled water for ideal humidity. Sensors regulate precise humidity level selected. The display informs when water needs to be replenished.



Fine cedar wood

Our ZKes 453 humidor features two presentation boxes and two wooden shelves crafted from Spanish cedar wood. The presentation boxes are ideal for storing loose cigars.



Wall mount option

Both the WKes 653 wine cabinet and ZKes 453 humidor can be wall-mounted as an attractive eye-catcher with convenient access for serving.



The pinnacle of indulgence

The ZKes 453 Humidor offers the ideal micro-climate for storing beloved cigars through fully-customisable humidity settings. Natural, handmade cigars are both delicate and sensitive, requiring a balanced mix of temperature and humidity to achieve the optimum flavour. The compartments in our humidor are crafted from Spanish cedar wood which allows its aroma to enhance the unique flavour of refined cigars.

For the ideal indulgence, pair the humidor with our WKes 653 Wine Cabinet. It has a compact footprint yet manages to hold up to 12 Bordeaux bottles. LED lighting and dimmer function ensures clear illumination for your selection of coveted wines.

Coated with a beautiful SmartSteel surface, both units are easy to clean and maintain. Opt to wall-mount this stunning pair to give it the attention it deserves.

LED

Wine

Smart
Steel

Cigar

WKes 653 | ZKes 453

Freestanding



←121→

XRCsdh 5266

Prime



SBNsdh 5264

Energy consumption (kWh/y)	195
Refrigerator capacity litre	177
BioFresh comp. litre	177
Freezer capacity litre	121
Number of shelves	2
Number of door racks	1
Number of freezer drawers	4 with LED lighting
Number of BioFresh drawers	2 with LED lighting
Electronic control	2.4" TFT-colour display, Touch & Swipe
Door / side walls	stainless steel with SmartSteel / silver
Refrigerator temperature range °C	+2°C to +14°C
Freezer temperature range °C	-15°C to -26°C
Temperature alarm	visual and acoustic
Defrost type	automatic
Interior light	LED ceiling lighting
Door alarm	visual and acoustic
IceMaker	fixed water connection 3/4"
Ice cube output kg/24h	1.2
SoftSystem	yes
Door hinges	left, reversible
Product dimensions (H/W/D) cm	185.5 / 59.7 / 67.5
Net weight kg	85.9
Voltage V/Hz	220-240/50-60

SRBsdh 5260

Energy consumption (kWh/y)	136
Refrigerator capacity litre	378
BioFresh comp. litre	133
Number of shelves	6
Number of door racks	4
Number of BioFresh drawers	3 with LED lighting
Electronic control	2.4" TFT-colour display, Touch & Swipe
Door / side walls	stainless steel with SmartSteel / silver
Refrigerator temperature range °C	+3°C to +9°C
Defrost type	automatic
Interior light	LED light panel on both sides
Door alarm	visual and acoustic
SoftSystem	yes
Door hinges	right, reversible
Product dimensions (H/W/D) cm	185.5 / 59.7 / 67.5
Net weight kg	83.9
Voltage V/Hz	220-240/50-60



Installation Diagram

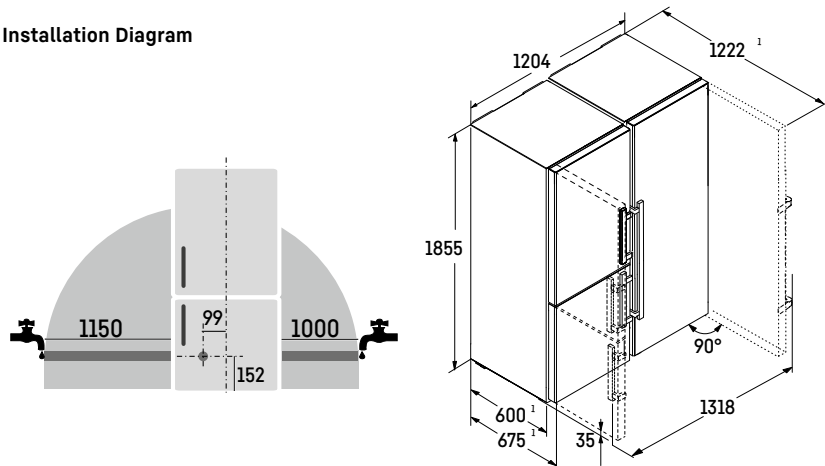

Freestanding

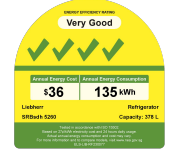

←121→

XRFsdh 5265

Prime



SFNSdh 5267

Energy consumption (kWh/y)	256
Freezer capacity litre	262
Number of freezer drawers	7
Electronic control	2.4" TFT-colour display, Touch & Swipe
Door / side walls	stainless steel with SmartSteel / silver
Freezer temperature range °C	-15°C to -28°C
Temperature alarm	visual and acoustic
Defrost type	automatic
Interior light	LED interior lighting
Door alarm	visual and acoustic
IceMaker	fixed water connection 3/4"
Ice cube output kg/24h	0.8
SoftSystem	yes
Door hinges	left, reversible
Product dimensions (H/W/D) cm	185.5 / 59.7 / 67.5
Net weight kg	83.3
Voltage V/Hz	220-240/50-60

SRBsdh 5260

Energy consumption (kWh/y)	136
Refrigerator capacity litre	378
BioFresh comp. litre	133
Number of shelves	6
Number of door racks	4
Number of BioFresh drawers	3 with LED lighting
Electronic control	2.4" TFT-colour display, Touch & Swipe
Door / side walls	stainless steel with SmartSteel / silver
Refrigerator temperature range °C	+3°C to +9°C
Defrost type	automatic
Interior light	LED light panel on both sides
Door alarm	visual and acoustic
SoftSystem	yes
Door hinges	right, reversible
Product dimensions (H/W/D) cm	185.5 / 59.7 / 67.5
Net weight kg	83.9
Voltage V/Hz	220-240/50-60



Installation Diagram

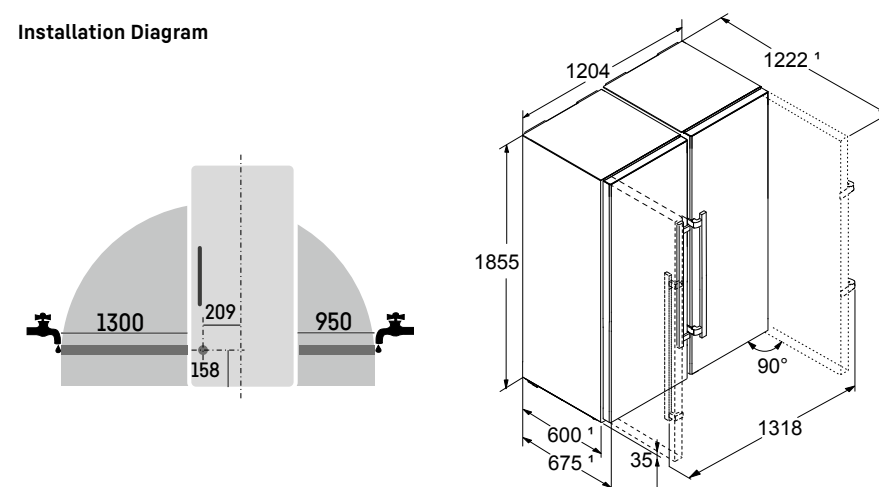



Freestanding



←121→

XCCsdh 5250

Prime



SCNsdh 5253

Energy consumption (kWh/y)	227
Refrigerator capacity litre	217
Freezer capacity litre	94
Number of shelves	5
Number of door racks	2
Number of freezer drawers	3 with LED lighting
Number of EasyFresh drawers	1
Electronic control	2.4" TFT-colour display, Touch & Swipe
Door / side walls	stainless steel with SmartSteel / silver
Refrigerator temperature range °C	+2°C to +9°C
Freezer temperature range °C	-15°C to -26°C
Temperature alarm	visual and acoustic
Defrost type	automatic
Interior light	LED light panel on both sides
Door alarm	visual and acoustic
SoftSystem	yes
Door hinges	left, reversible
Product dimensions (H/W/D) cm	185.5 / 59.7 / 67.5
Net weight kg	85.5
Voltage V/Hz	220-240/50-60

SCNsdh 5253

Energy consumption (kWh/y)	227
Refrigerator capacity litre	217
Freezer capacity litre	94
Number of shelves	5
Number of door racks	2
Number of freezer drawers	3 with LED lighting
Number of EasyFresh drawers	1
Electronic control	2.4" TFT-colour display, Touch & Swipe
Door / side walls	stainless steel with SmartSteel / silver
Refrigerator temperature range °C	+2°C to +9°C
Freezer temperature range °C	-15°C to -26°C
Temperature alarm	visual and acoustic
Defrost type	automatic
Interior light	LED light panel on both sides
Door alarm	visual and acoustic
SoftSystem	yes
Door hinges	right, reversible
Product dimensions (H/W/D) cm	185.5 / 59.7 / 67.5
Net weight kg	83.7
Voltage V/Hz	220-240/50-60

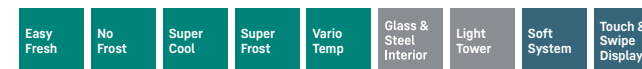

Installation Diagram

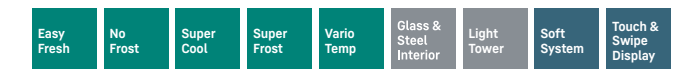
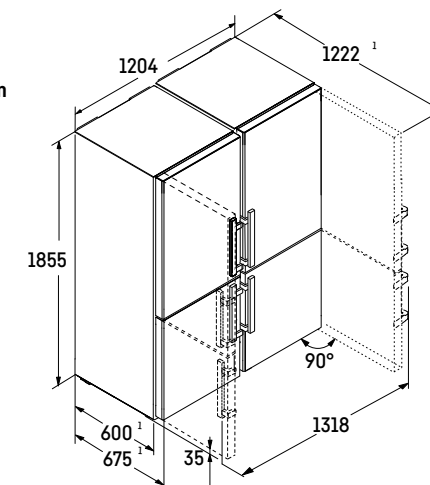

Freestanding



← 75 →

CBNsdh 7653
Prime

Energy consumption (kWh/y)	228
Refrigerator capacity litre	282
BioFresh comp. litre	71
Freezer capacity litre	128
Number of shelves	6
Number of door racks	2
Number of freezer drawers	3 with LED lighting
Number of BioFresh drawers	1 with LED lighting
Electronic control	2.4" TFT-colour display, Touch & Swipe
Door / side walls	stainless steel with SmartSteel / silver
Refrigerator temperature range °C	+3°C to +9°C
Freezer temperature range °C	-15°C to -26°C
Temperature alarm	visual and acoustic
Defrost type	automatic
Interior light	LED light panel on both sides
Door alarm	visual and acoustic
SoftSystem	yes
Door hinges	right, reversible
Product dimensions (H/W/D) cm	185.5 / 74.7 / 67.5
Net weight kg	98.4
Voltage V/Hz	220-240/50-60

Bio Fresh	Duo Cooling	No Frost	Super Cool	Super Frost	Glass & Steel Interior	Light Tower	Easy Twist Ice	Soft System
Soft-Telescopic Rails	Touch & Swipe Display	Vario Space						

Installation Diagram

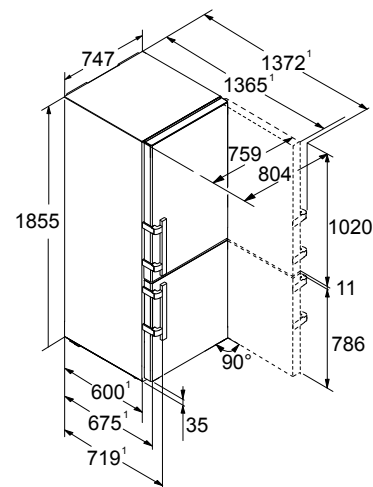

← 60 →

SCNsdh 5253
Prime

Energy consumption (kWh/y)	227
Refrigerator capacity litre	229
Freezer capacity litre	103
Number of shelves	5
Number of door racks	2
Number of freezer drawers	3 with LED lighting
Number of EasyFresh drawers	1
Electronic control	2.4" TFT-colour display, Touch & Swipe
Door / side walls	stainless steel with SmartSteel / silver
Refrigerator temperature range °C	+3°C to +9°C
Freezer temperature range °C	-15°C to -26°C
Temperature alarm	visual and acoustic
Defrost type	automatic
Interior light	LED light panel on both sides
Door alarm	visual and acoustic
SoftSystem	yes
Door hinges	right, reversible
Product dimensions (H/W/D) cm	185.5 / 59.7 / 67.5
Net weight kg	83.7
Voltage V/Hz	220-240/50-60

Easy Fresh	Duo Cooling	No Frost	Super Cool	Super Frost	Glass & Steel Interior	Light Tower	Soft System	Touch & Swipe Display
Vario Space								

Installation Diagram

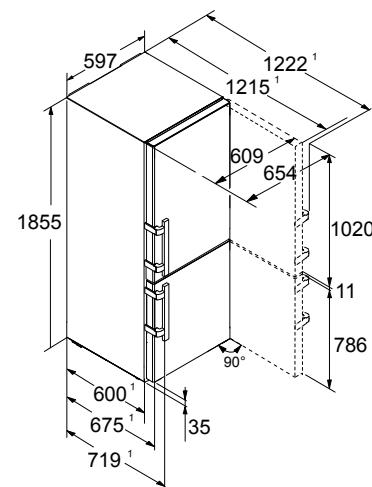

↑ 178 ↓

ICBNh 5173
Peak

Energy consumption (kWh/y)	181
Refrigerator capacity litre	172
BioFresh comp. litre	69
Freezer capacity litre	67
Number of shelves	4
Number of door racks	2
Number of freezer drawers	3 with LED lighting
Number of BioFresh drawers	2 with LED lighting
Electronic control	2.4" TFT-colour display, Touch & Swipe
Refrigerator temperature range °C	+3°C to +9°C
Freezer temperature range °C	-15°C to -26°C
Temperature alarm	visual and acoustic
Defrost type	automatic
Interior light	LED light panel on both sides
Door alarm	visual and acoustic
IceMaker	fixed water connection 3/4"
Ice cube output kg/24h	1.2
SoftSystem	yes
Door hinges	left, reversible
Product dimensions (H/W/D) cm	177 / 55.9 / 54.6
Cut out dimensions (H/W/D) cm	177.2-178.8 / 56-57 / 55
Net weight kg	77.4
Voltage V/Hz	220-240/50-60

Bio Fresh Professional	Hydro Breeze	Duo Cooling	No Frost	Super Cool	Super Frost	Glass & Steel Interior	Light Tower	Ice Maker
Soft System	Soft-Telescopic Rails	Touch & Swipe Display	Vario Space					

Installation Diagram

NB: The cupboard door is attached to the appliance door (door on door assembly). No cupboard hinges required.

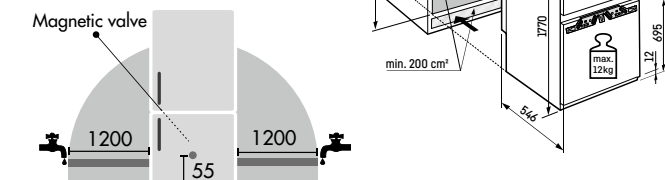

Fully Integrated



↑ 178 ↓

ICNh 5173
Peak

Energy consumption (kWh/y)	176
Refrigerator capacity litre	174
Freezer capacity litre	69
Number of shelves	6
Number of door racks	3
Number of freezer drawers	3 with LED lighting
Number of EasyFresh drawers	1
Electronic control	2.4" TFT-colour display, Touch & Swipe
Refrigerator temperature range °C	+2°C to +9°C
Freezer temperature range °C	-15°C to -26°C
Temperature alarm	visual and acoustic
Defrost type	automatic
Interior light	LED light panel on both sides
Door alarm	visual and acoustic
SoftSystem	yes
Door hinges	right, reversible
Product dimensions (H/W/D) cm	177 / 55.9 / 54.6
Cut out dimensions (H/W/D) cm	177.2-178.8 / 56-57 / 55
Net weight kg	73.5
Voltage V/Hz	220-240/50-60

Easy Fresh	Duo Cooling	No Frost	Super Cool	Super Frost	Glass & Steel Interior	Light Tower	Soft System	Touch & Swipe Display
Vario Space								

Installation Diagram

NB: The cupboard door is attached to the appliance door (door on door assembly). No cupboard hinges required.

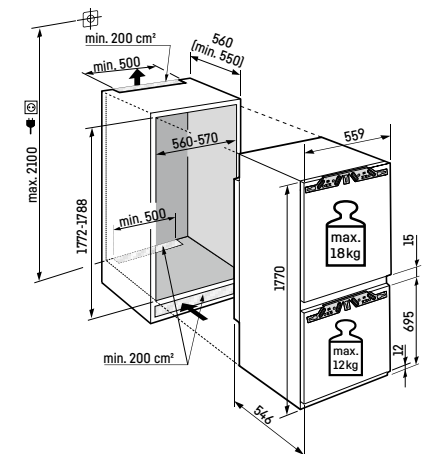

Fully Integrated



ICNh 5133
Plus

Energy consumption (kWh/y)	182
Refrigerator capacity litre	182
Freezer capacity litre	67
Number of shelves	5
Number of door racks	3
Number of freezer drawers	3
Number of EasyFresh drawers	1
Electronic control	LCD display monochrome, touch electronic
Refrigerator temperature range °C	+2°C to +9°C
Freezer temperature range °C	-15°C to -26°C
Temperature alarm	visual and acoustic
Defrost type	automatic
Interior light	LED ceiling lighting
Door alarm	visual and acoustic
IceMaker	watertank
Ice cube output kg/24h	1.2
SoftSystem	yes
Door hinges	right, reversible
Product dimensions (H/W/D) cm	177 / 55.9 / 54.6
Cut out dimensions (H/W/D) cm	177.2-178.8 / 56-57 / 55
Net weight kg	68.5
Voltage V/Hz	220-240/50-60

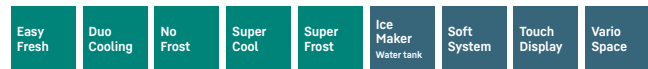

Installation Diagram

NB: The cupboard door is attached to the appliance door (door on door assembly). No cupboard hinges required.

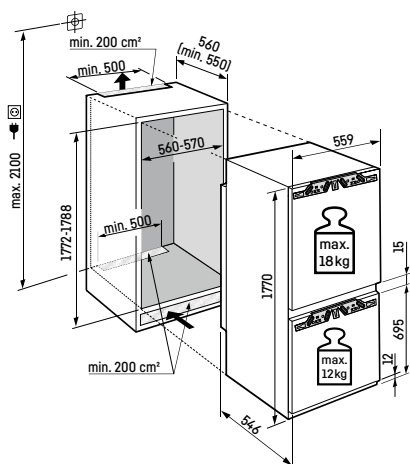

Fully Integrated



ICNh 5123
Plus

Energy consumption (kWh/y)	176
Refrigerator capacity litre	182
Freezer capacity litre	69
Number of shelves	6
Number of door racks	3
Number of freezer drawers	3
Number of EasyFresh drawers	1
Electronic control	LCD display monochrome, touch electronic
Refrigerator temperature range °C	+2°C to +9°C
Freezer temperature range °C	-15°C to -26°C
Temperature alarm	visual and acoustic
Defrost type	automatic
Interior light	LED ceiling lighting
Door alarm	visual and acoustic
SoftSystem	yes
Door hinges	right, reversible
Product dimensions (H/W/D) cm	177 / 55.9 / 54.6
Cut out dimensions (H/W/D) cm	177.2-178.8 / 56-57 / 55
Net weight kg	66.9
Voltage V/Hz	220-240/50-60



Installation Diagram

NB: The cupboard door is attached to the appliance door (door on door assembly). No cupboard hinges required.

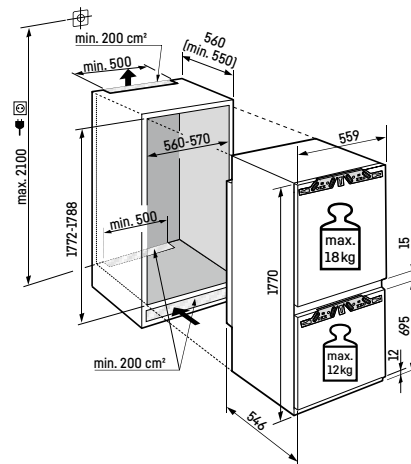

ICNh 5103
Pure

Energy consumption (kWh/y)	252
Refrigerator capacity litre	182
Freezer capacity litre	69
Number of shelves	4
Number of door racks	3
Number of freezer drawers	3
Number of EasyFresh drawers	1
Electronic control	LCD display monochrome, touch electronic
Refrigerator temperature range °C	+2°C to +9°C
Freezer temperature range °C	-15°C to -26°C
Temperature alarm	visual and acoustic
Defrost type	automatic
Interior light	LED ceiling lighting
Door alarm	visual and acoustic
Door hinges	right, reversible
Product dimensions (H/W/D) cm	177 / 55.9 / 54.6
Cut out dimensions (H/W/D) cm	177.2-178.8 / 56-57 / 55
Net weight kg	62.2
Voltage V/Hz	220-240/50-60



Installation Diagram

NB: The cupboard door is attached to the appliance door (door on door assembly). No cupboard hinges required.

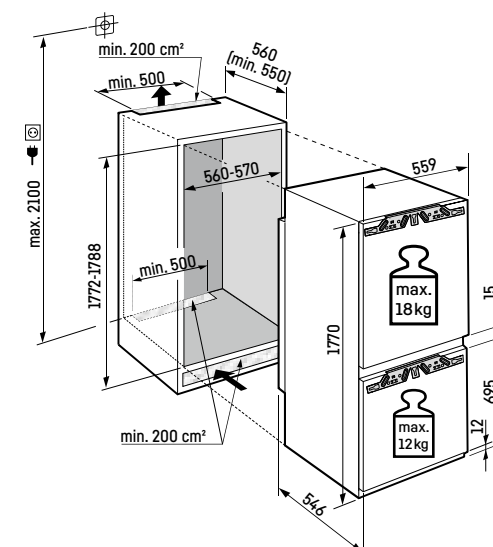

Fully Integrated

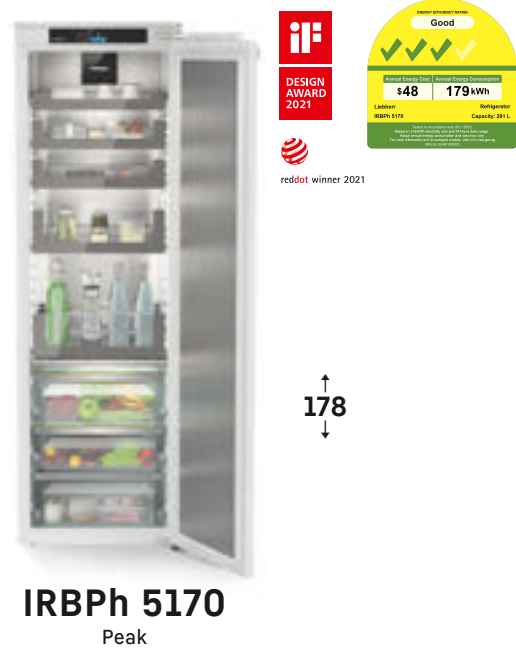

IRBPh 5170
Peak

Energy consumption (kWh/y)	164
Refrigerator capacity litre	291
BioFresh comp. litre	96
Number of OpenStage drawers	5
Number of BioFresh drawers	3 with LED lighting
Electronic control	2.4" TFT-colour display, Touch & Swipe
Refrigerator temperature range °C	+3 °C to +9 °C
Defrost type	automatic
Interior light	LED light panel on both sides
Door alarm	visual and acoustic
SoftSystem	yes
Door hinges	right, reversible
Product dimensions (H/W/D) cm	177 / 55.9 / 54.6
Cut out dimensions (H/W/D) cm	177.2-178.8 / 56-57 / 55
Net weight kg	99.9
Voltage V/Hz	220-240/50-60

- Bio Fresh
- Super Cool
- Open Stage
- Glass & Steel Interior
- Light Tower
- Soft System
- Soft-Telescopic Rails
- Touch & Swipe Display

Installation Diagram

NB: The cupboard door is attached to the appliance door (door on door assembly).
No cupboard hinges required.

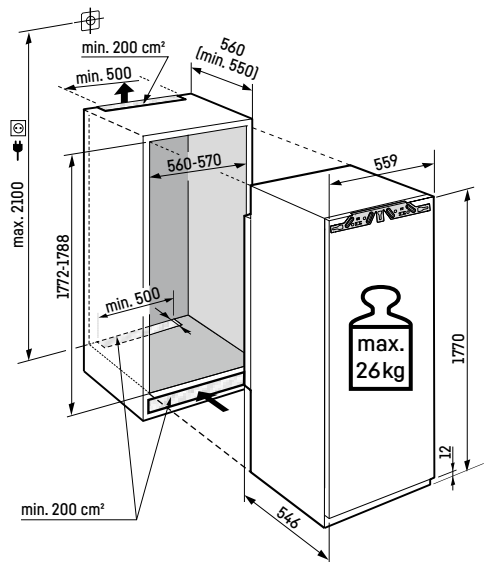

Fully Integrated



SIFNh 5188
Peak

Energy consumption (kWh/y)	398
Freezer capacity litre	200
Number of freezer drawers	8
Electronic control	2.4" TFT-colour display, Touch & Swipe
Freezer temperature range °C	-15 °C to -28 °C
Temperature alarm	visual and acoustic
Defrost type	automatic
Interior light	LED interior lighting
Door alarm	visual and acoustic
IceMaker	fixed water connection 3/4"
Ice cube output kg/24h	1.2
SoftSystem	yes
Door hinges	left, reversible
Product dimensions (H/W/D) cm	177 / 55.9 / 54.6
Cut out dimensions (H/W/D) cm	177.2-178.8 / 56-57 / 55
Net weight kg	74
Voltage V/Hz	220-240/50-60

- No Frost
- Super Frost
- LED
- Ice Tower
- Soft System
- Telescopic Rails
- Touch & Swipe Display
- Vario Space

Installation Diagram

NB: The cupboard door is attached to the appliance door (door on door assembly).
No cupboard hinges required.

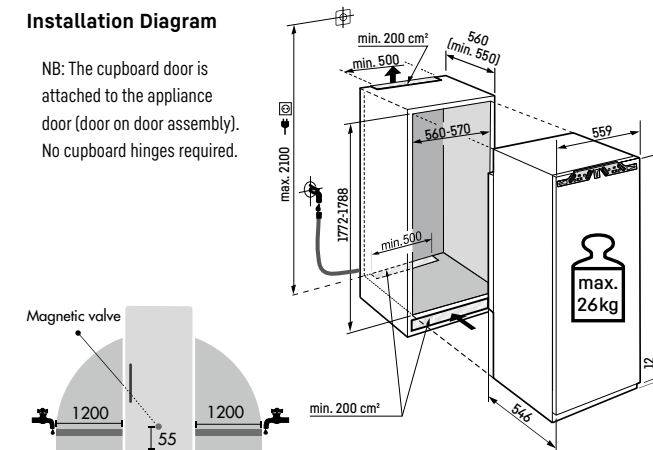

IRBh 5170
Peak

Energy consumption (kWh/y)	164
Refrigerator capacity litre	287
BioFresh comp. litre	92
Number of shelves	8
Number of door racks	4
Number of BioFresh drawers	3 with LED lighting
Electronic control	2.4" TFT-colour display, Touch & Swipe
Refrigerator temperature range °C	+3 °C to +9 °C
Defrost type	automatic
Interior light	LED light panel on both sides
Door alarm	visual and acoustic
SoftSystem	yes
Door hinges	right, reversible
Product dimensions (H/W/D) cm	177 / 55.9 / 54.6
Cut out dimensions (H/W/D) cm	177.2-178.8 / 56-57 / 55
Net weight kg	76.5
Voltage V/Hz	220-240/50-60

- Bio Fresh Professional
- Hydro Breeze
- Fish & Seafood
- Super Cool
- Glass & Steel Interior
- Light Tower
- Soft System
- Soft-Telescopic Rails
- Touch & Swipe Display

Installation Diagram

NB: The cupboard door is attached to the appliance door (door on door assembly).
No cupboard hinges required.

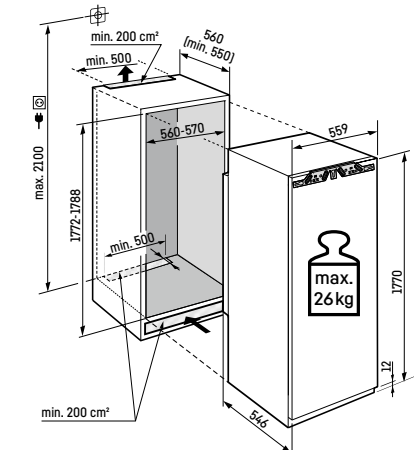



Fully Integrated



ECBN 8872



ECBN 7870

Energy consumption (kWh/y)	338
Refrigerator capacity litre	357
BioFresh comp. litre	68
Freezer capacity litre	114
Number of shelves	4
Number of door racks	6
Number of freezer drawers	2 with LED lighting
Number of BioFresh drawers	2 with LED lighting
Electronic control	MagicEye with digital temp. display, touch electronic
Refrigerator temperature range °C	+3°C to +7°C
Freezer temperature range °C	-14°C to -27°C
Temperature alarm	visual and acoustic
Defrost type	automatic
Interior light	LED light column on both sides and LED ceiling lighting
Door alarm	acoustic
Water filter	yes
IceMaker	fixed water connection 3/4"
Ice cube output kg/24h	1.4
SoftSystem	yes
Door hinges	left / right
Product dimensions (H/W/D) cm	202.7 / 91 / 61
Cut out dimensions (H/W/D) cm	203.2-207.2 / 91.5 / 63.5
Net weight kg	160
Voltage V/Hz	220-240/50/60

Bio Fresh	Duo Cooling	No Frost	Super Cool	Super Frost	Light Tower	Ice Maker	Flex Door System	Soft System
-----------	-------------	----------	------------	-------------	-------------	-----------	------------------	-------------

Installation Diagram

Reinforced flexible hose (3m) for appliances with a 3/4" plumbed-in connection.
 NB: The cupboard door is attached to the appliance door (door on door assembly).
 No cupboard hinges required.

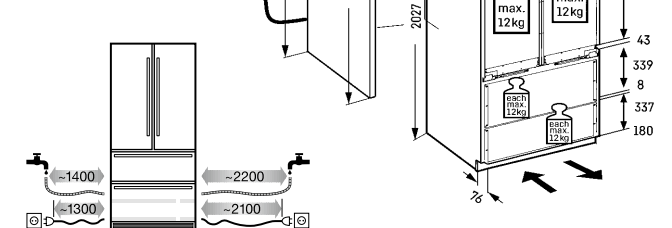

Energy consumption (kWh/y)	326
Refrigerator capacity litre	276
BioFresh comp. litre	57
Freezer capacity litre	103
Number of shelves	4
Number of door racks	3
Number of freezer drawers	2 with LED lighting
Number of BioFresh drawers	2 with LED lighting
Electronic control	MagicEye with digital temp. display, touch electronic
Refrigerator temperature range °C	+3°C to +7°C
Freezer temperature range °C	-14°C to -27°C
Temperature alarm	visual and acoustic
Defrost type	automatic
Interior light	LED light column on both sides
Door alarm	acoustic
Water filter	yes
IceMaker	fixed water connection 3/4"
Ice cube output kg/24h	1.2
SoftSystem	yes
Door hinges	right, reversible
Product dimensions (H/W/D) cm	202.7 / 75.7 / 61
Cut out dimensions (H/W/D) cm	203.2-207.2 / 76.2 / 63.5
Net weight kg	145
Voltage V/Hz	220-240/50/60

Bio Fresh	Duo Cooling	No Frost	Super Cool	Super Frost	Ice Maker	Soft System
-----------	-------------	----------	------------	-------------	-----------	-------------

Installation Diagram

Reinforced flexible hose (3m) for appliances with a 3/4" plumbed-in connection.
 NB: The cupboard door is attached to the appliance door (door on door assembly).
 No cupboard hinges required.

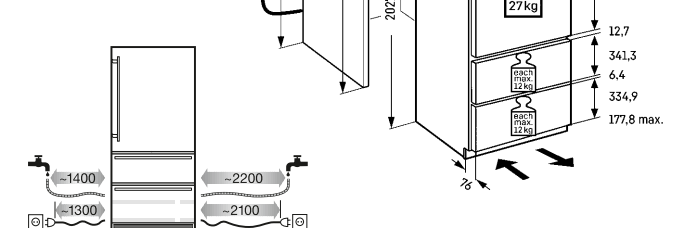



Side by Side

82-88

SUIKo 1550
Premium

Energy consumption (kWh/y)	158
Refrigerator capacity litre	124
Number of shelves	2
Number of fruit and vegetable drawers	1
Electronic control	MagicEye with LCD temp. display, key electronic
Refrigerator temperature range °C	+2°C to +9°C
Defrost type	automatic
Interior light	LED ceiling lighting
Door alarm	visual and acoustic
Door type	steel
Door hinges	pullout
Product dimensions (H/W/D) cm	82 / 59.7 / 55
Cut out dimensions (H/W/D) cm	82-88 / 60 / 55
Net weight kg	43.6
Voltage V/Hz	220-240/50

Super Cool Soft-Telescopic Rails

Installation Diagram

NB: The cupboard door is attached to the appliance door (door on door assembly). No cupboard hinges required. Plinth height at appliance height of 820 mm (height of worktop 850 mm) adjustable between 100 and 160 mm, or between 163 and 223 mm at appliance height of 880 mm (height of worktop 900 mm). Depth of plinth 22-77 mm.

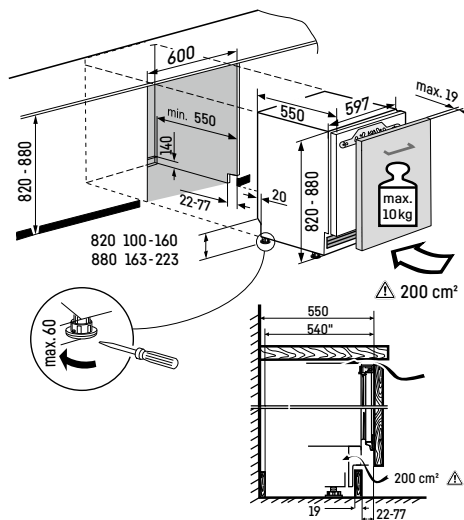

Side by Side

82-88

SUIG 1514
Comfort

Energy consumption (kWh/y)	168
Freezer capacity litre	95
Number of freezer drawers	3
Electronic control	MagicEye with LCD temp. display, key electronic
Freezer temperature range °C	-14°C to -26°C
Temperature alarm	visual and acoustic
Defrost type	manual
Door alarm	visual and acoustic
Door type	steel
SoftSystem	yes
Door hinges	left, reversible
Product dimensions (H/W/D) cm	82 / 59.7 / 55
Cut out dimensions (H/W/D) cm	82-88 / 60 / 55
Net weight kg	41
Voltage V/Hz	220-240/50

Smart Frost Super Frost Soft System Vario Space

Installation Diagram

NB: The cupboard door is attached to the appliance door (door on door assembly). No cupboard hinges required. Plinth height at appliance height of 820 mm (height of worktop 850 mm) adjustable between 100 and 160 mm, or between 163 and 223 mm at appliance height of 880 mm (height of worktop 900 mm). Depth of plinth 22-77 mm.

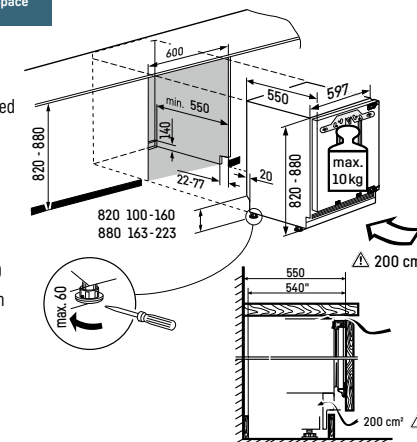

Side by Side

82-88

SUIK 1510
Comfort

Energy consumption (kWh/y)	147
Refrigerator capacity litre	136
Number of shelves	4
Number of door racks	2
Number of fruit and vegetable drawers	1
Electronic control	MagicEye with LCD temp. display, key electronic
Refrigerator temperature range °C	+2°C to +9°C
Defrost type	automatic
Interior light	LED interior lighting
Door alarm	visual and acoustic
Door type	steel
SoftSystem	yes
Door hinges	right, reversible
Product dimensions (H/W/D) cm	82 / 59.7 / 55
Cut out dimensions (H/W/D) cm	82-88 / 60 / 55
Net weight kg	36.5
Voltage V/Hz	220-240/50/60

Super Cool Soft System

Installation Diagram

NB: The cupboard door is attached to the appliance door (door on door assembly). No cupboard hinges required. Plinth height at appliance height of 820 mm (height of worktop 850 mm) adjustable between 100 and 160 mm, or between 163 and 223 mm at appliance height of 880 mm (height of worktop 900 mm). Depth of plinth 22-77 mm.

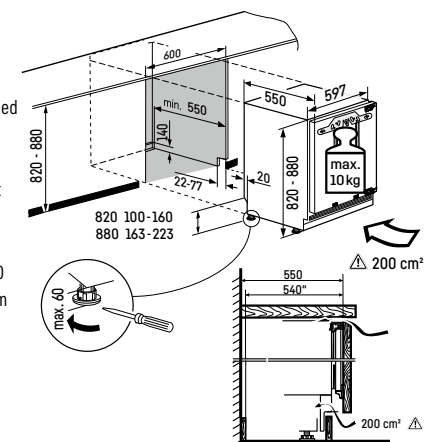



← 70 →

WPgbh 7473
Vinidor Selection

Total capacity litre	562
Max. No. of Bordeaux bottles (0.75l) *	182
Total no. of storage shelves (incl. bottom compartment)	12
Shelves on telescopic rails	9
Shelf material	beech wood shelves
Electronic control	2.4" TFT-colour display for 3 wine zones, Touch & Swipe
Temperature range °C	+5 °C to +20 °C
Temperature zones	3
Temperature alarm	visual and acoustic
Interior light	LED light panel, both sides permanently on, dimmable
Door alarm	visual and acoustic
Door type	insulated glass door with BlackSteel frame
Integrated lock	yes
SoftSystem	yes
Door hinges	right, reversible
Product dimensions (H/W/D) cm	201.3 / 69.7 / 76.4
Net weight kg	150.6
Voltage V/Hz	220-240/50-60

3 Zones	Temp Protect Plus	Storage Zone	Fresh Air	UV Protect Plus	Flex Fit	Vibrate Safe	Steel Interior	Light Tower
Soft System	Telescopic Rails	Touch & Swipe Display	eDoor Lock					

Installation Diagram

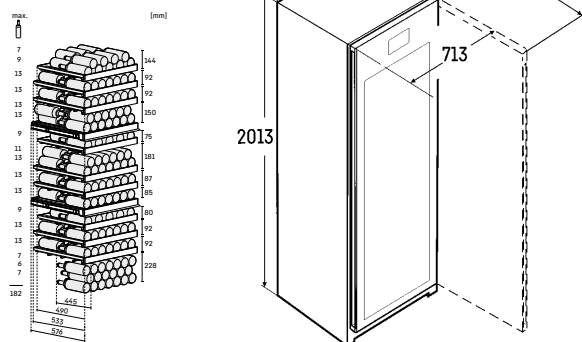

← 60 →

WPbs 5262
Vinidor

Total capacity litre	368
Max. No. of Bordeaux bottles (0.75l) *	155
Total no. of storage shelves (incl. bottom compartment)	8
Shelf material	beech wood shelves
Presentation shelf	1
Electronic control	2.4" TFT-colour display for both wine zones, Touch & Swipe
Temperature range °C	+5 °C to +20 °C
Temperature zones	2
Temperature alarm	visual and acoustic
Interior light	LED zone lighting permanently on, dimmable
Door alarm	visual and acoustic
Door type	insulated glass door with BlackSteel frame
Integrated lock	yes
Door hinges	right, reversible
Product dimensions (H/W/D) cm	185.4 / 59.7 / 67.5
Net weight kg	94
Voltage V/Hz	220-240/50-60

2 Zones	Temp Protect Plus	Humidity Select	Fresh Air	UV Protect Plus	Vibrate Safe	Steel Interior	LED	Touch & Swipe Display
eDoor Lock								

Installation Diagram

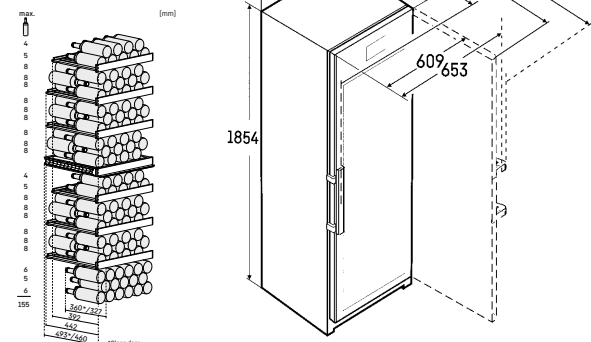

← 60 →

WPsd 5262
Vinidor

Total capacity litre	368
Max. No. of Bordeaux bottles (0.75l) *	155
Total no. of storage shelves (incl. bottom compartment)	8
Shelf material	beech wood shelves
Electronic control	2.4" TFT-colour display for both wine zones, Touch & Swipe
Temperature range °C	+5 °C to +20 °C
Temperature zones	2
Temperature alarm	visual and acoustic
Interior light	LED zone lighting permanently on, dimmable
Door alarm	visual and acoustic
Door type	glass door with stainless steel frame and SmartSteel
Integrated lock	yes
SoftSystem	yes
Door hinges	right, reversible
Product dimensions (H/W/D) cm	185.4 / 59.7 / 67.5
Net weight kg	94.3
Voltage V/Hz	220-240/50-60

2 Zones	Temp Protect Plus	Humidity Select	Fresh Air	UV Protect Plus	Vibrate Safe	Steel Interior	LED	Soft System
Touch & Swipe Display	eDoor Lock							

Installation Diagram

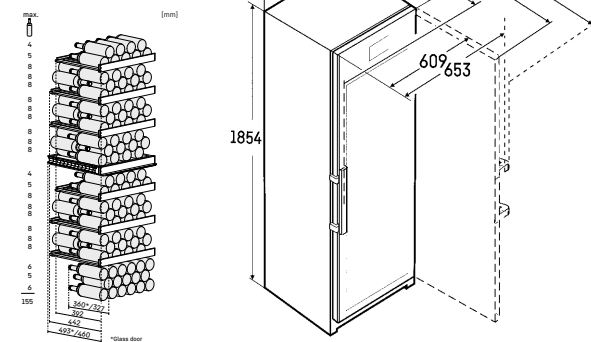

← 60 →

WPsd 4652
Vinidor

Total capacity litre	272
Max. No. of Bordeaux bottles (0.75l) *	107
Total no. of storage shelves (incl. bottom compartment)	6
Shelf material	beech wood shelves
Electronic control	LCD display monochrome for both wine zones, touch electronic
Temperature range °C	+5 °C to +20 °C
Temperature zones	2
Temperature alarm	visual and acoustic
Interior light	LED zone lighting permanently on, dimmable
Door alarm	visual and acoustic
Door type	glass door with stainless steel frame and SmartSteel
Integrated lock	yes
Door hinges	right, reversible
Product dimensions (H/W/D) cm	145.4 / 59.7 / 67.5
Net weight kg	77.7
Voltage V/Hz	220-240/50-60

2 Zones	Temp Protect Plus	Humidity Select	Fresh Air	UV Protect Plus	Vibrate Safe	Steel Interior	LED	Touch Display
---------	-------------------	-----------------	-----------	-----------------	--------------	----------------	-----	---------------

Installation Diagram

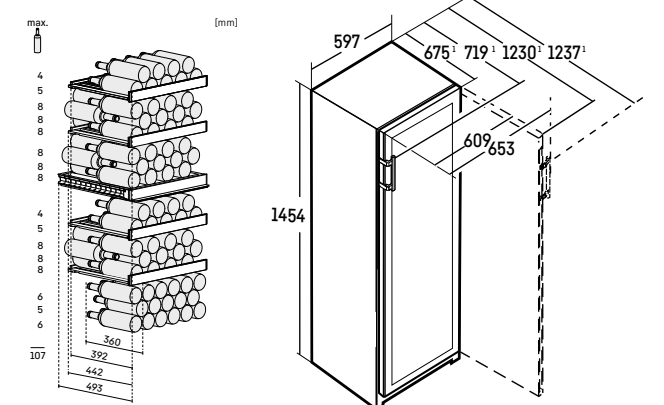



WSbl 7731
GrandCru Selection

Total capacity litre	627
Max. No. of Bordeaux bottles (0.75l) *	324
Total no. of storage shelves (incl. bottom compartment)	7
Shelf material	beech wood shelves
Electronic control	LCD display monochrome, touch electronic
Refrigerator temperature range °C	+5°C to +20°C
Temperature range °C	+5°C to +20°C/+5°C to +20°C
Temperature zones	1
Temperature alarm	visual and acoustic
Interior light	LED ceiling light
Door alarm	visual and acoustic
Door type	full door, black
Integrated lock	yes
Door hinges	right, reversible
Product dimensions (H/W/D) cm	204.4 / 74.7 / 76.3
Net weight kg	91
Voltage V/Hz	220-240/50/60

- 1 Zone
- Temp Protect Plus
- Humidity Control
- Fresh Air
- Vibrate Safe
- Steel Interior
- LED
- Touch Display
- eDoor Lock

- Self Closing Door
- Easy Fill

Installation Diagram

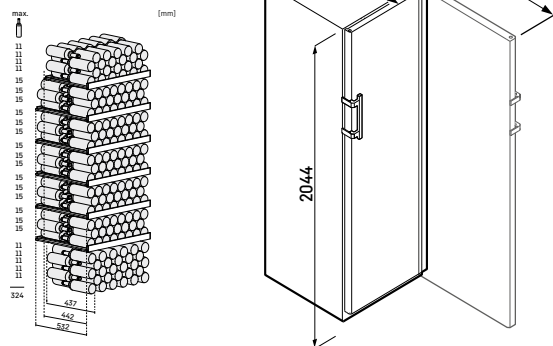

WPbli 5231
GrandCru Selection

Total capacity litre	442
Max. No. of Bordeaux bottles (0.75l) *	229
Total no. of storage shelves (incl. bottom compartment)	6
Shelf material	beech wood shelves
Electronic control	LCD display monochrome, touch electronic
Refrigerator temperature range °C	+5°C to +20°C
Temperature range °C	+5°C to +20°C/+5°C to +20°C
Temperature zones	1
Temperature alarm	visual and acoustic
Interior light	LED light one-sided permanently on, dimmable
Door alarm	visual and acoustic
Door type	insulated glass door, frame black
Integrated lock	yes
Door hinges	right, reversible
Product dimensions (H/W/D) cm	188.4 / 59.7 / 76.3
Net weight kg	91
Voltage V/Hz	220-240/50/60

- 1 Zone
- Temp Protect Plus
- Humidity Control
- Fresh Air
- Vibrate Safe
- Steel Interior
- Light Column
- Presentation Light
- Touch Display

- Door Lock
- Self Closing Door
- Easy Fill

Installation Diagram

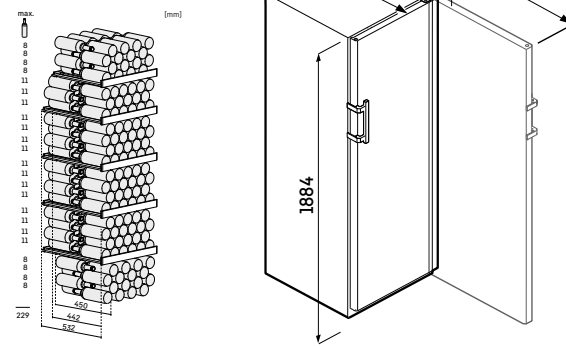

EWTdf 3553
Vinidor

Total capacity litre	256
Max. No. of Bordeaux bottles (0.75l) *	80
Total no. of storage shelves (incl. bottom compartment)	10
Shelves on telescopic rails	8
Shelf material	beech wood shelves
Presentation shelf	1
Electronic control	LCD temp. display for both wine zones, touch electronic
Temperature range °C	+5°C to +20°C
Temperature zones	2
Temperature alarm	visual and acoustic
Interior light	LED lighting permanently on, dimmable
Door alarm	acoustic
Safety thermostat	yes
Activated Charcoal filter	yes
Door type	panel ready or stainless steel panel as accessory
SoftSystem	yes
Door hinges	right, reversible
Product dimensions (H/W/D) cm	177 / 55.7 / 55.3
Cut out dimensions (H/W/D) cm	177.2-178 / 56-57 / 55
Net weight kg	94
Voltage V/Hz	220-240/50/60

- 2 Zones
- Humidity Select
- Fresh Air
- UV Protect
- Vibrate Safe
- Steel Interior
- LED
- Soft System
- Telescopic Rails

- Presentation Board

Installation Diagram

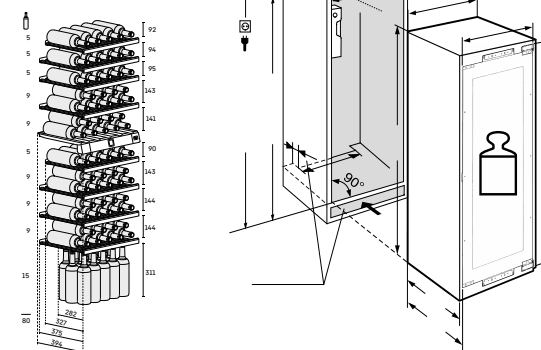



UWTes 1672
Vinidor

Energy consumption (kWh/y)	190
Total capacity litre	94
Max. No. of Bordeaux bottles (0.75l) *	34
Total no. of storage shelves (incl. bottom compartment)	5
Shelves on telescopic rails	3
Shelf material	beech wood shelves
Electronic control	MagicEye with digital temp. display for both wine zones, key electronic
Temperature range °C	+5°C to +20°C
Temperature zones	2
Temperature alarm	visual and acoustic
Interior light	LED lighting permanently on, dimmable
Door alarm	acoustic
Safety thermostat	yes
Activated Charcoal filter	yes
Door type	glass door with stainless steel frame
Integrated lock	yes
Door hinges	right, reversible
Product dimensions (H/W/D) cm	81.8 / 59.7 / 57.7
Cut out dimensions (H/W/D) cm	82-87 / 60 / 58
Net weight kg	49
Voltage V/Hz	220-240/50



UWKes 1752
GrandCru

Energy consumption (kWh/y)	145
Total capacity litre	112
Max. No. of Bordeaux bottles (0.75l) *	46
Total no. of storage shelves (incl. bottom compartment)	4
Shelves on telescopic rails	3
Shelf material	beech wood shelves
Electronic control	MagicEye with digital temp. display, key electronic
Temperature range °C	+5°C to +20°C
Temperature zones	1
Temperature alarm	visual and acoustic
Interior light	LED lighting permanently on
Door alarm	acoustic
Safety thermostat	yes
Activated Charcoal filter	yes
Door type	glass door with stainless steel frame
Integrated lock	yes
Door hinges	right, reversible
Product dimensions (H/W/D) cm	81.8 / 59.7 / 57.7
Cut out dimensions (H/W/D) cm	82-87 / 60-61 / 58
Net weight kg	44
Voltage V/Hz	220-240/50



WKES 553
GrandCru

Energy consumption (kWh/y)	106
Total capacity litre	47
Max. No. of Bordeaux bottles (0.75l) *	18
Total no. of storage shelves (incl. bottom compartment)	3
Shelves on telescopic rails	2
Shelf material	beech wood shelves
Electronic control	LCD temp. display, touch electronic
Temperature range °C	+5°C to +20°C
Temperature zones	1
Temperature alarm	visual and acoustic
Interior light	LED lighting permanently on, dimmable
Door alarm	acoustic
Activated Charcoal filter	yes
Door type	glass door with stainless steel frame
Door hinges	right, reversible
Product dimensions (H/W/D) cm	45.5 / 59.1 / 52.2
Cut out dimensions (H/W/D) cm	45 / 56 / 55
Net weight kg	30
Voltage V/Hz	220-240/50



Installation Diagram

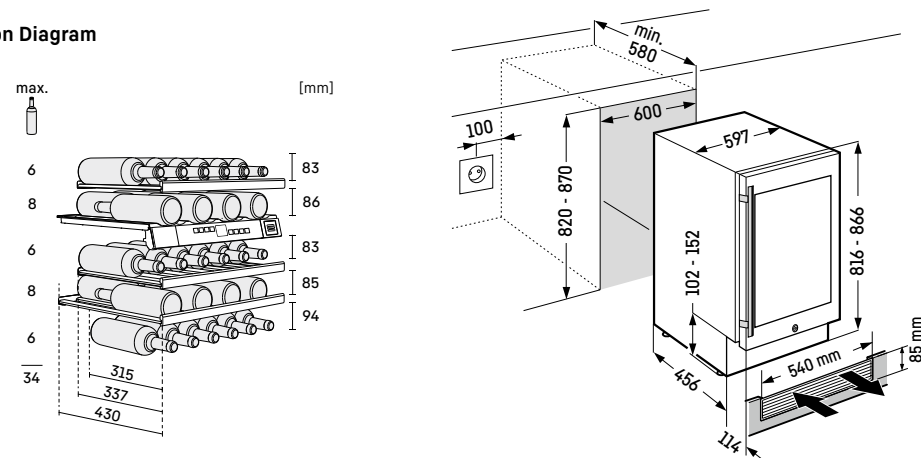

Installation Diagram

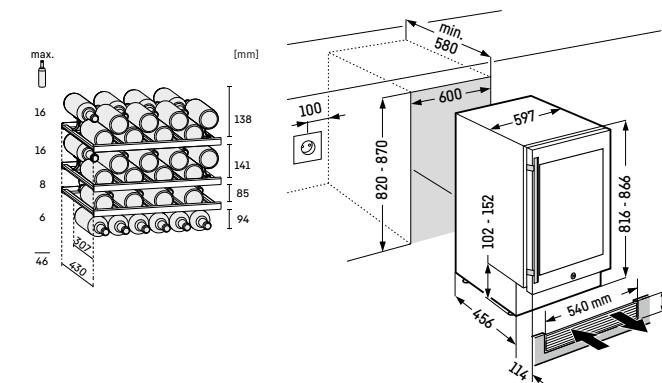

Installation Diagram

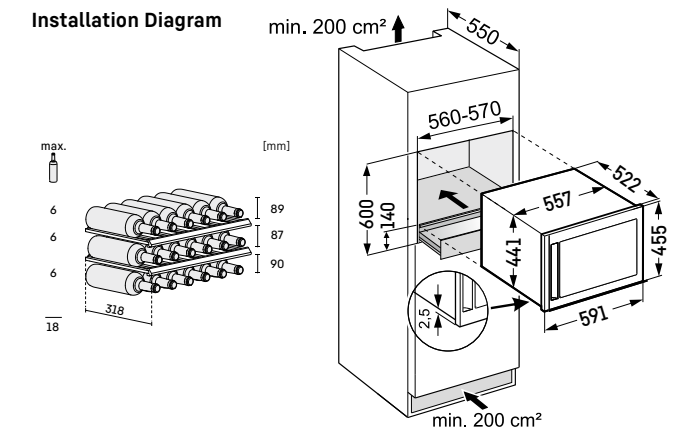



WKb 4612
Barrique

Energy consumption (kWh/y)	204
Total capacity litre	336
Max. No. of Bordeaux bottles (0.75l) *	195
Total no. of storage shelves (incl. bottom compartment)	7
Shelf material	beech wood shelves
Presentation shelf	1
Electronic control	MagicEye with digital temp. display, key electronic
Temperature range °C	+5 °C to +20 °C
Temperature zones	1
Temperature alarm	visual and acoustic
Interior light	LED interior lighting
Door alarm	acoustic
Safety thermostat	yes
Activated Charcoal filter	yes
Door type	insulated glazed door, black frame
Integrated lock	yes
Door hinges	right, reversible
Product dimensions (H/W/D) cm	184.2 / 65.7 / 66.3
Net weight kg	86
Voltage V/Hz	220-240/50



Installation Diagram

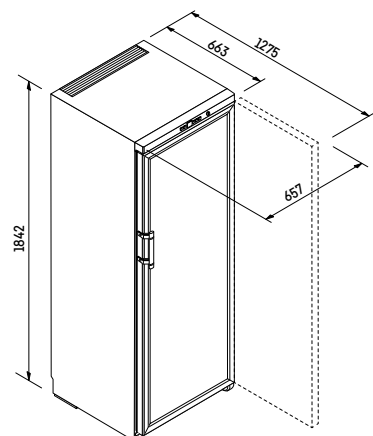

WKb 4611
Barrique

Energy consumption (kWh/y)	175
Total capacity litre	336
Max. No. of Bordeaux bottles (0.75l) *	195
Total no. of storage shelves (incl. bottom compartment)	7
Shelf material	beech wood shelves
Electronic control	MagicEye with digital temp. display, key electronic
Temperature range °C	+5 °C to +20 °C
Temperature zones	1
Temperature alarm	visual and acoustic
Interior light	light bulb
Door alarm	acoustic
Safety thermostat	yes
Activated Charcoal filter	yes
Door type	full door with handle, black
Integrated lock	yes
Door hinges	right, reversible
Product dimensions (H/W/D) cm	184.2 / 65.7 / 66.3
Net weight kg	68.5
Voltage V/Hz	220-240/50



Installation Diagram

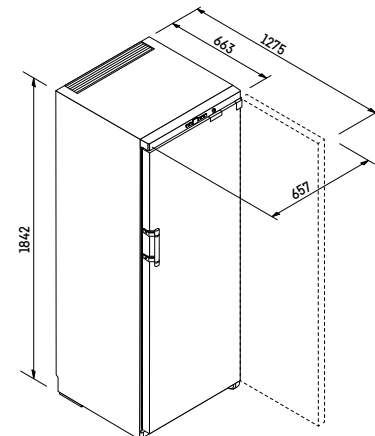

WKb 4112
Barrique

Energy consumption (kWh/y)	178
Total capacity litre	293
Max. No. of Bordeaux bottles (0.75l) *	168
Total no. of storage shelves (incl. bottom compartment)	6
Shelves on telescopic rails	1
Shelf material	beech wood shelves
Presentation shelf	1
Electronic control	MagicEye with digital temp. display, key electronic
Temperature range °C	+5 °C to +20 °C
Temperature zones	1
Temperature alarm	visual and acoustic
Interior light	LED interior lighting
Door alarm	acoustic
Safety thermostat	yes
Activated Charcoal filter	yes
Door type	insulated glazed door, black frame
Integrated lock	yes
Door hinges	right, reversible
Product dimensions (H/W/D) cm	164.6 / 65.7 / 66.3
Net weight kg	78
Voltage V/Hz	220-240/50



Installation Diagram

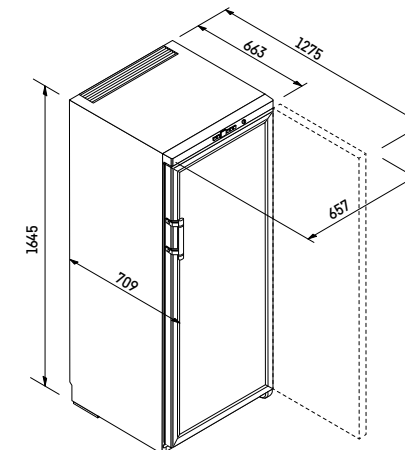

WKb 1712
Barrique

Energy consumption (kWh/y)	149
Total capacity litre	121
Max. No. of Bordeaux bottles (0.75l) *	60
Total no. of storage shelves (incl. bottom compartment)	3
Shelf material	beech wood shelves
Electronic control	MagicEye with digital temp. display, key electronic
Temperature range °C	+5 °C to +20 °C
Temperature zones	1
Temperature alarm	visual and acoustic
Interior light	LED interior lighting
Door alarm	acoustic
Safety thermostat	yes
Activated Charcoal filter	yes
Door type	insulated glazed door, black frame
Integrated lock	yes
Door hinges	right, reversible
Product dimensions (H/W/D) cm	85 / 65.7 / 66.3
Net weight kg	45
Voltage V/Hz	220-240/50



Installation Diagram

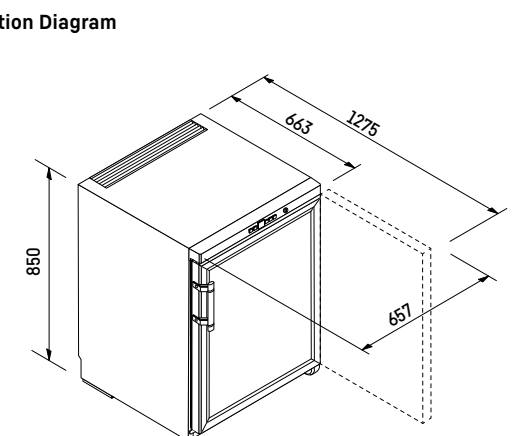



WKes 653
GrandCru

Energy consumption (kWh/y)	75
Total capacity litre	38
Max. No. of Bordeaux bottles (0.75l) *	12
Total no. of storage shelves (incl. bottom compartment)	3
Shelf material	beech wood shelves
Electronic control	LCD temp. display, touch electronic
Temperature range °C	+5°C to +20°C
Temperature zones	1
Temperature alarm	visual and acoustic
Interior light	LED lighting permanently on, dimmable
Door alarm	acoustic
Activated Charcoal filter	yes
Door type	glass door with stainless steel frame and SmartSteel
Integrated lock	yes
Door hinges	right
Product dimensions (H/W/D) cm	61.2 / 42.5 / 47.8
Net weight kg	29
Voltage V/Hz	220-240/50



Installation Diagram

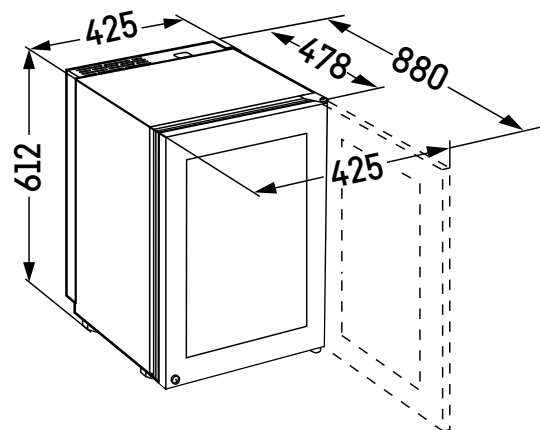
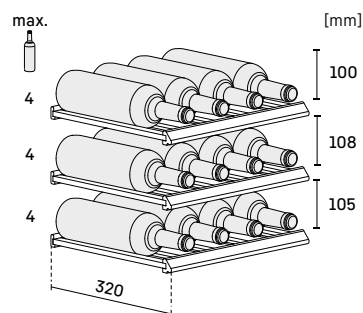

* These models are only bound for storing wine. Maximum DIN norm bordeaux bottles capacity (0.75 l) as per norm NF H 35-124 (H: 300.5 mm, Ø 76.1 mm).



ZKes 453
Humidor

Energy consumption (kWh/y)	162
Total capacity litre	39
Total no. of storage shelves (incl. bottom compartment)	2
Shelf material	Spanish cedar wood shelves
Electronic control	LCD temp. display, touch electronic
Temperature range °C	+16°C to +20°C
Temperature zones	1
Temperature alarm	visual and acoustic
Defrost type	automatic
Interior light	LED lighting permanently on, dimmable
Door alarm	acoustic
Activated Charcoal filter	yes
Door type	glass door with stainless steel frame and SmartSteel
Integrated lock	yes
Door hinges	right
Product dimensions (H/W/D) cm	61.2 / 42.5 / 47.8
Net weight kg	30
Voltage V/Hz	220-240/50



Installation Diagram

