Opening up New Horizons

PR 746 G8 – PR 756 G8

LIEBHERR

Crawler dozers



Precision and speed³

Generation 8



Liebherr Operator Assistance Systems



Be creative.

Active Blade Stabilisation for free grading.



Achieve high standards.

Active Blade Positioning, position display and control. For levelling ground with specified longitudinal grade and cross slope.

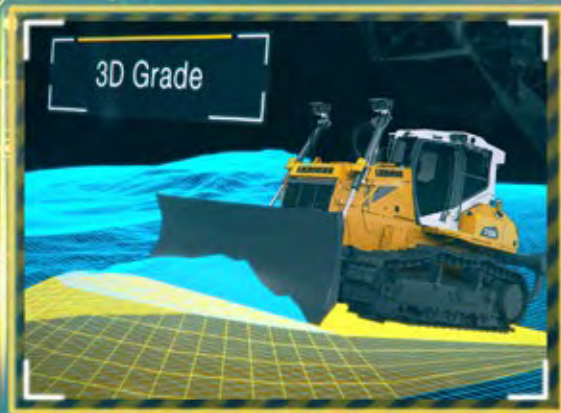

Precision in every dimension.

Roof-mounted TOPCON as an option 3D machine control ex-works for creating complex 3D site models.

Performance

When you have big plans you want the big Liebherr performance.

Profitability

The best investment for cost-effective construction.

Reliability

You can rely on your equipment 100%.

Comfort

Liebherr Silent Design:
A comfortable operator is a productive operator.

Service

On-site for you:
A worldwide service network.

The driver's dozer

Moving the earth and shaping horizons.





PR 746 G8 Litronic

Operating weight

25.900–31.500 kg / 57,100–69,446 lb

Engine rating

190 kW / 258 HP

Stage IIIA, V / Tier 4f

Blade capacity

6.00–7.20 m³ / 7.85–9.42 yd³

PR 756 G8 Litronic

Operating weight

35,400–43,000 kg / 78,044–94,799 lb

Engine rating

260 kW / 353 HP

Stage IIIA, V / Tier 4f

Blade capacity

8.92–11.80 m³ / 11.67–15.43 yd³

Performance



When you have big plans you need a big performance.

These dozers will shift huge volumes of material quickly, regardless of weather or ground conditions. Whether you're developing a site or working in a mine you'll get impressive pushing speed from the hydrostatic drive and peak productivity using the operator assistance systems.

Liebherr mining performance in the 30- and 40-tonne classes.

Your goal is peak performance.

Every manoeuvre should demand the ideal combination of speed and traction. Liebherr crawler dozers let you choose the highest possible speed for the operating conditions and will call up full thrust at any time via the joystick.

Fully automatic without compromise means perfect breakout force on any terrain.

With Liebherr hydrostatic drive, the machine automatically and continuously delivers the correct traction when ripping and without any gear changes. At the end of ripping, the first strip, the rear ripper is raised automatically at the push of a button. The undercarriage design provides a low centre of gravity while the fixed ripper control with mini joystick ensures stability when tackling stony or steep terrains. *

A bonus in pushing speed.

If the ground is loose, simply select a higher speed range. Thanks to the electronic pilot control you can not set the machine's speed but select the reactivity and speed of the operating hydraulics in the display. Generation 8 crawler dozers can be equipped with Liebherr's tough heavy-duty blade.

Keep mining operations on track.

Safe on slopes at top speed.

When operating on slopes and embankments, the machine assists via automatic speed monitoring. The Hill Assist function with automatic parking brake makes light work of hill starts and the Liebherr drive system eliminates the need for a wear-intensive foot brake.

Finish faster with Liebherr Assistance Systems.

The standard Liebherr Free Grade provides active blade stabilisation when grading surfaces, ramps and embankments with longitudinal and transverse slopes. Together with two other modes – Definition Grade and 3D Grade (optional) – this system will help even experienced operators to boost productivity and save time. In addition, you can keep an eye on all mining parameters to maintain cost-effective and productive control of your operations.

Effective power and economy in eco mode.

Re-cultivate the site after extracting materials of value by switching to the environment-friendly eco mode for light work and material transfer. This enables you to achieve both the required pushing performance but with the best fuel economy.



More powerful Liebherr diesel engine.

We install our own diesel engines – designed specifically for heavy construction machinery – in our crawler dozers and in tandem with the hydrostatic drive that means your machine will generate top tractive power at any speed.



Automate operating movements.

- Quick Drop: Rapid lowering of the blade
- Auto Blade: Automatic raising and lowering of the blade.
- Automatic lifting of the rear ripper at the push of a button



Assistance systems as standard.

'Free Grade' and 'Definition Grade' assistance systems make life easier on road construction, maintenance or mining operations. And they come fitted as standard – without complex 3D machine control.

* Now included as standard for the PR 736 to PR 776 size crawler dozers.

Profitability



Seize the Day: join Liebherr to create the infrastructure and Earth of tomorrow

Wind, water and mobility are all aspects of the energy transition where the Liebherr Group applies key technologies and components to make a valuable contribution. The latest generation of crawler dozer can play a vital role in infrastructure projects through cost-effective operations, supported by intelligent assistance systems and standard ECO-Mode, to Smart construction site management using myLiebherr.

Leave nothing to chance.

Profitable operation starts with transportation.

At Liebherr, we focus our development on the over-all process because cost-effective crawler dozer use is determined by all the processes in daily work situations. As a result, your new Liebherr machine and its 6-way folding blade can be transported without the use of special tools or a special transport permit. Also, the operation of a hydro-statically controlled machine is so simple and intuitive that every truck driver can load it safely. And manoeuvring is made even easier using the optional reversing camera.

Your choice.

You decide how much 'power' the Liebherr crawler dozer will give you.

If large quantities of material require to be shifted, the hydrostatic drive works at constant engine speed to save resources and minimise costs.

The larger blade capacities of the Generation 8 machines give additional reserves of power but when a lighter touch is called for, the operator can switch to the Eco mode. Generation 8 ranks particularly well in heavily built-up commercial areas due to its low noise emissions...and that means less damage to the environment every time.

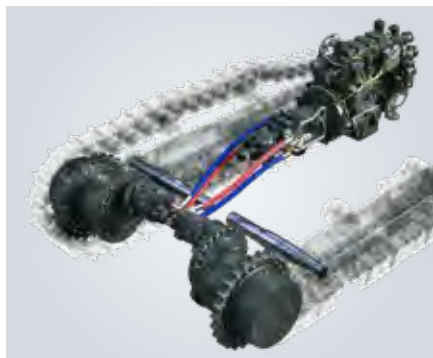

Advanced ideas and innovation.

With ground-breaking concepts such as stepless drive with adaptive tractive force adjustment, joystick control, Drive by Wire and automatic speed control, we always impress our customers.

Machine intelligence that supports you.

Definition Grade – the new site laser.

In level 2 of the new Liebherr Operator Assistance Systems, Definition Grade allows you to model a 2D surface without a rotating laser; all that's required is a reference point from the site surveyor.

With the blade automatically lowering to the reference measurement, the creation of a precise 2D surface is child's play, even over large distances and in different pushing directions. And all this without the need for a laser or complex machine controls with satellite connection. At the same time, Liebherr technology enables grading speeds that previously could not be achieved.

Smart service logistics – myLiebherr.

Know where you stand with LiDAT, a fleet management tool that provides information on location as well as operation of your construction machinery.

That information includes the machine's position, its operating and usage duration, fuel consumption and service interval information. With LiDAT you can plan your next service and be prepared for upcoming maintenance. For more urgent support just notify your service partner and order the right spare part from your mobile phone via myLiebherr and it will be on its way with express delivery.



HVO Ready

Liebherr engines are suitable for operation with plant-based alternative fuels (HVO) to help make an important contribution to a significant reduction of a customer's CO₂ footprint.



Liebherr Remote Control (Lirecon) is productive, efficient and reliable

- Quick shift changes between drivers
- Reduced downtime
- Safe work in danger zones

Reliability



Equipment you can rely on to make the Earth move.

Liebherr dozers can be programmed to precisely match your working conditions and to reach the pinnacle of production. The high-quality engineering inherent in Generation 8 extends across the entire life of the machine.

Safety without compromise.

Check: All systems are go.

Demanding tasks require your full attention. With a glance at the new 9-inch touch display you'll be comfortable knowing that all operating parameters are in the green range. And whether for CB radio, a tablet or kettle, the full 12- and 24-volt supply with two USB sockets ensures everyone is connected.

Dependable on any terrain.

The continuously variable hydrostatic Liebherr drive shows its strengths particularly when driving on extremely soft ground. With permanent traction on both drive tracks, the machine can be manoeuvred without changing gear, free from jerking. In combination with good weight distribution, the dozer is always safe and sure-footed on the move.

Minimise risk.

When spreading material, you'll be surprised at the ground clearance; the compact design of the hydrostatic drive components means the centre of gravity is very low. Normal drive (low drive) operates particularly well on softer ground with the bonus of exceptionally low noise levels. A demand-driven hydrostatic fan saves energy and lowers noise levels even further.

Be properly equipped.

Long-lasting drive.

You can rely on the standard tracks from Liebherr for all jobs and all sites. Fitting a wide drive for the lowest ground pressure and a FTB (Free Turning Bushings) track will pay dividends on high abrasion applications. Track bushes on the FTB undercarriage are free turning and base plates are provided with cleaning holes to extend the service life of the track and sprockets.

Man and machine in harmony.

We focus our design development on the way you, the customer, works. Once in the driving seat, you will experience the perfect integration of your workplace into the surrounding environment with clear visibility to all sides. Familiarise yourself with the intuitive control, because all driving functions have been reduced to a central control element. The cutting-edge drive system always delivers the necessary thrust when asked and maintains the selected speed, even when the going gets tough – the only limits are physical constraints and your own creativity. Operators are protected by the restraint system and integrated ROPS/FOPS protection. The integrated, electronically controlled protection mechanisms with automatic maximum load control and on-board monitoring allows the freedom to fully exploit the dozer's potential over prolonged periods.

Advanced digital development, tried and tested on site

From stability analyses, to visual and operating simulations and vibration behaviour: Our products are put through numerous tests as virtual prototypes, in combination with the full range of digital 3D engineering design tools, and in daily use on construction sites they prove themselves all over the world.

Tough machines demand tough equipment

Particularly high grade materials are used on the face and cutting edges of Liebherr blade equipment. The perfect solution for every application is available from the wide selection and varied range of equipment offered.

The highest level of quality, in everything we do

The Liebherr promise: the highest level of quality and a real contribution to the success and profitability of our customers. This is our top priority. To do this, we adapt the latest manufacturing methods to meet the specific requirements of our products and continuously invest in the modernisation of our production facilities.

Comfort



Liebherr Silent Design: Making sense of your senses

Crawler dozer operators depend on their senses as well as their machines. With effective shock absorption, the latest Generation 8 dozer filters out vibrations but you still have the full feedback to form the perfect level. Reassuring Operator Assistance Systems help you to achieve and exceed your goals for productivity and precision. The digital display interface means you always keep your objective in sight.

From workplace to workspace.

Start your shift in safety and comfort.

As a crawler dozer operator, you play a leading role on a construction site and are frequently one of the first into action. So we at Liebherr make sure your machine is ready and waiting with lighting for access and exit as well as in the engine compartment while centralised maintenance points mean faster and easier early morning inspections.

Setting up your 'office'.

From the start, you'll feel at home in the spacious cabin by adjusting the seat and joysticks to match your own ergonomic needs. A seat contact switch will detect your presence, so belt up and get dozing. The new 9-inch touch display provides access to all key parameters and individual settings for the drive and operating hydraulics.

Seeing is believing

An advanced lighting layout illuminates even the outermost corners around the machine. With large glass surfaces, sloping shapes for containers and carefully considered positioning of exhaust pipe and driver's seat, you have a clear overview even in tight spaces.

Your strength. Your versatility.

The digital construction site.

Now you can model simple 2D surfaces instantly and be prepared for complex construction jobs. With location sharing, our LiDAT fleet management and configuration with the integrated 3D technology, all necessary 3D data for your project can be imported and displayed directly via Sitelink 3D.

Work in high definition.

Topcon's optional roof-mounted 3D kit is already fitted and calibrated ex-works and the fully automatic machine control positions the 6-way blade exactly in all three dimensions. The open architecture and standardised terrain models enable simple integration into digital construction site processes.

'Ready' for Trimble and Leica.

Pre-installed kits are available as an option for setting up the latest 2D and 3D machine controls from manufacturers Trimble and Leica. The Ready Kits give you option to upgrade the dozer at any time.



New 9-inch Touch user interface.

- Operating status
- Service notifications
- Configuration of drive and operating hydraulics
- ECO Mode
- Liebherr Operator Assistance



Intelligent Liebherr control.

In a Generation 8 crawler dozer you're ready for the future:

- Highly automated stepless drive
- Electronically controlled operating hydraulics
- Automated operating movements
- Advanced machine interface



Spacious, quiet and comfortable cabin.

- Access and exit step lighting
- Climate control
- Cold storage compartment
- 12 V and 24 V plug socket
- 2 USB sockets

Service



At your service on site: our worldwide service network

Our focus on customer satisfaction is in our genetic profile. That is why Liebherr service is just a phone call away - regardless of where you are in the world. Our network of service partners guarantees quick and professional support directly on site. For Liebherr, speed and reliability are an integral part of our service provision. Because short reaction times directly reduce downtime and contribute restoring your machine's productivity quickly.

A perfect start to the working day.

Keep it simple

Daily maintenance before start-up should never be a chore; it is, after all, a vital factor for long machine service life. As the key points of maintenance are centralised, daily inspection is simple, quick and easy.

Focus on serviceability.

All service points are readily accessible via easy grips and steps that let the service engineer start his work quickly and safely. With engine compartment lighting and diagnostic ports routed out for access, an overview of the machine status can be gained quickly and without fuss. The standard hydraulically tilting cab has easy access to the drive components, even in the field.

Service when it counts.

Breakdown is not an option.

A service notification will interrupt usual daily progress and that's why the objective of the Liebherr service chain is maximum machine availability. Short response times and fast deliveries are critical.

Time saved = money saved.

Through LiDAT fleet management, the Liebherr service technician will, with your consent, call up the location of the machine directly and receive information on upcoming service tasks. Via the myLiebherr customer portal you can gain online access to the latest spare parts documentation for the machine and order directly from your Liebherr service partner.

Strong service partner.

Depend on us today...and tomorrow.

With Liebherr you can rely on long-term support and certainty. Liebherr and our service partners are the guarantors for this back-up.

Worldwide service network.

Service support points all over the world make 'close to you' a reality. Technical experts from Liebherr's service partners are always ready to provide support.

Tailor-made service agreements.

A single source for all service needs, Liebherr's service agreements provide for secure investment and increased profitability from your machine.



Simple cleaning of the radiator.

Liebherr crawler dozers are fitted with a swivelling fan as standard and with a quick-release fastener as an option. This allows cleaning from the outside in double-quick time. An optional reversible fan is recommended for self-cleaning, particularly in dust-intensive applications.



Trained service engineer.

All customer service technicians undergo intensive training and continuous professional development. This embraces remote diagnostics and fault analysis as well as a fast answer on the correct solution.



Spare parts over 30 hectares.

The high-bay warehouse in our international logistics centre has around 60,000 automated pallets and 33,000 manual storage spaces and the small parts warehouse has 122,000 container storage spaces. This is where we store spare parts of weights from one gram to 40 tonnes.

The driver's dozer



Move the earth. Shift horizons.

As a driver, you are at the centre of operations and share responsibility for the success of projects. You fulfil the specified requirements on time and always find appropriate solutions. A Liebherr Generation 8 crawler dozer lets you use your skills and capability to the full. You are goal-orientated and creative in your work and will benefit from the latest digital dozer technology on each assignment.



Be ambitious.

On site, you call the shots:

Where every tonne makes a difference and cost-effective operations are crucial, a dozer operator will make a major contribution, from supply of material to site and storage capacity management. You will adapt a Liebherr crawler dozer to the demands of the job.

Shape and form the terrain.

The powerful features of Liebherr Assistance Systems are evident when creating the vehicle's site access. Definition Grade lets you create a precise formation level including the required surface inclination.

With the optional 3D Grade machine control, simple 3D surface models can be created directly on the display for execution in automatic mode.

Make complex tasks look easy.

For stockpiling, the extended blade will speed up work and on loose aggregate and softer ground, the new Generation 8 dozer proves its worth: With a low centre of gravity and consistent power to both tracks, even cross-slope pushing looks easy.

Sensors maintain your current driving speed and keep you perfectly in line. Active braking downhill is not necessary.

High standards.

You'll love your new workplace.

Even under the most extreme operations and all types of weather, you'll be impressed by the creature comforts. The advanced cabin, with hydro-elastic mountings, offers the lowest sound levels and effective absorption of vibrations and together with first-class seating and joystick ergonomics, even long working days can be taken in your stride.

Service the machine quickly and safely.

Whatever the weather, maintenance of the Liebherr crawler dozers is quick, easy and safe, a particular emphasis in our product development. It starts out with the engineering design, where technicians design and then test the positioning of maintenance points using virtual reality. Features include a readily accessible dipstick and fluid filler nozzles, exposed lubrication points for the equaliser bar and maintenance-free bearings.

The importance of sustainability.

Even when your work is done, there are still features of the new Liebherr crawler dozer that will come as a pleasant surprise. With real-time Load Sensing*, the machine calls up only the hydraulic power currently needed. Excess energy, however, is not dissipated, as is normally the case with conventional systems. This protects the components and reduces diesel consumption. Also, the high-temperature combustion in the Liebherr diesel engine and exhaust gas after-treatment with the SCR filter (combined diesel particle filter and selective catalyst with AdBlue injection)* helps protect the environment.

* Depending on model

Highlights Generation 8

Precision and speed

- Exceptional grading performance
- Liebherr Operator Assistance Systems (OAS)

Intelligent, efficient and productive

- Electronically controlled drive with ECO mode

Relaxed work environment

- Liebherr Silent Design
- Premium comfort cab





Flexible, adapts to the way you work

- Electronically controlled operating hydraulics
- Human-machine interaction

Future-proof technology

- Advanced Liebherr diesel engine
- "BIM ready"
- 3D site modelling (3D Grade)
- MyLiebherr service portal



Technical data PR 746

Engine

Liebherr Diesel engine	D 936 A7 Emission regulations according to 97/68/EC, 2004/26/EC stage V/stage IIIA, EPA/CARB Tier 4f
Rated power (net) ISO 9249 SAE J1349	190 kW / 258 HP 190 kW / 254 HP
Maximum power (net) ISO 9249 SAE J1349	210 kW / 286 HP 210 kW / 281 HP
Rated speed	1,600 rpm
Displacement	10.5 l / 641 in ³
Design	6 cylinder in-line engine, water-cooled, turbocharged, air-to-air intercooler
Injection system	Direct fuel injection, Common Rail, electronic control
Lubrication	Pressurised lube system, engine lubrication guaranteed for inclinations up to 45°, on all sides
Operating voltage	24 V
Alternator	140 A
Starter	7.8 kW / 11 HP
Batteries	2 x 180 Ah / 12 V
Air cleaner	Dry type air filter with vacuum indicator and automatic dust ejector, main and safety element
Cooling system	Combi radiator, comprising radiators for water and charge air. Hydrostatic fan drive

Hydraulics

Hydraulic system	Load sensing (demand-controlled)
Pump type	Swash plate piston pump
Pump flow, max.	256 l/min. / 67.6 gpm / 56.3 Imp.gpm
Pressure limitation	260 bar / 3,770 psi
Control valve	2 segments, expandable to 4
Filter system	Return filter with magnetic rod in the hydraulic tank
Control	Single joystick for all blade functions

Travel drive

Transmission system	Infinitely variable hydrostatic travel drive, independent drive for each track
Travel speed* Speed range 1: Speed range 2: Speed range 3:	Continuously variable 0 - 6.5 km/h / 4.0 mph (forward & reverse) 0 - 8.5 km/h / 5.3 mph (forward & reverse) 0 - 11.0 km/h / 6.8 mph (forward & reverse) *Travel speed ranges can be set on the travel joystick (memory function)
Electronic system	The electronic system automatically adjusts travel speed and drawbar pull to match changing load conditions
Steering	Hydrostatic
Service brake	Hydrostatic (self-locking), wear-free
Parking brake	Multi-disc brake, wear-free, automatically applied with neutral joystick position
Cooling system	Separate oil cooler, hydraulic fan drive
Filter system	Micro cartridge filter in replenishing circuit
Final drive	Combination spur gear with planetary gear, double-sealed (duo cone seals) with temperature indicator
Control	Single proportional joystick for all travel and steering functions

Operator's cab

Cab	Hydro-elastic mounted cab with positive pressure ventilation, can be tilted with hand pump 40° to the rear. With integrated ROPS Rollover Protective Structure (EN ISO 3471) and FOPS Falling Objects Protective Structure (EN ISO 3449)
Operator's seat	Air suspended comfort seat, fully adjustable
Monitoring	Touch screen: display of current machine information, automatic monitoring of operating conditions, individual setting of machine parameters
Vibration emission Hand / arm vibrations Whole-body vibrations	< 2.5 m/s ² , according with ISO 5349-1:2001 0.24 - 1.31 m/s ² , complies with technical report ISO/TR 25398:2006
Measuring inaccuracy	According with standard EN 12096:1997

Undercarriage

	L	LGP
Design	Undercarriage with rigid bottom rollers	
Mounting	Via separate pivot shafts and equalizer bar	
Track chains	Lubricated, single-grouser shoes, tensioning via steel spring and grease tensioner	
Links, each side	41	44
Track rollers, each side	7	8
Carrier rollers, each side	2	2
Sprocket segments, each side	6	6
Track shoes, standard	610 mm / 24"	812 mm / 32"
Track shoes, optional	560 mm / 22" 711 mm / 28"	914 mm / 36"

Sound levels

Operator sound exposure ISO 6396	
L _{pA} (in the cab)	75 dB(A)
Exterior sound pressure 2000/14/EC	
L _{WA} (to the environment)	112 dB(A)

Refill capacities

Fuel tank	505 l / 133.3 gal / 111.1 Imp.gal
Diesel Exhaust Fluid (DEF) tank¹⁾	56.5 l / 14.9 gal / 12.4 Imp.gal
Cooling system	49 l / 12.9 gal / 10.8 Imp.gal
Engine oil, with filter	43 l / 11.4 gal / 9.5 Imp.gal
Splitter box	8.5 l / 2.2 gal / 1.9 Imp.gal
Hydraulic tank	112 l / 29.6 gal / 24.6 Imp.gal
Final drive L, each side	17 l / 4.5 gal / 3.7 Imp.gal
Final drive LGP, each side	18 l / 4.8 gal / 4.0 Imp.gal

¹⁾ only for stage V/Tier 4f

Drawbar pull

Max.	436 kN
at 1.5 km/h / 0.9 mph	385 kN
at 3.0 km/h / 1.9 mph	190 kN
at 6.0 km/h / 3.7 mph	95 kN
at 9.0 km/h / 5.6 mph	63 kN

Dimensions PR 746

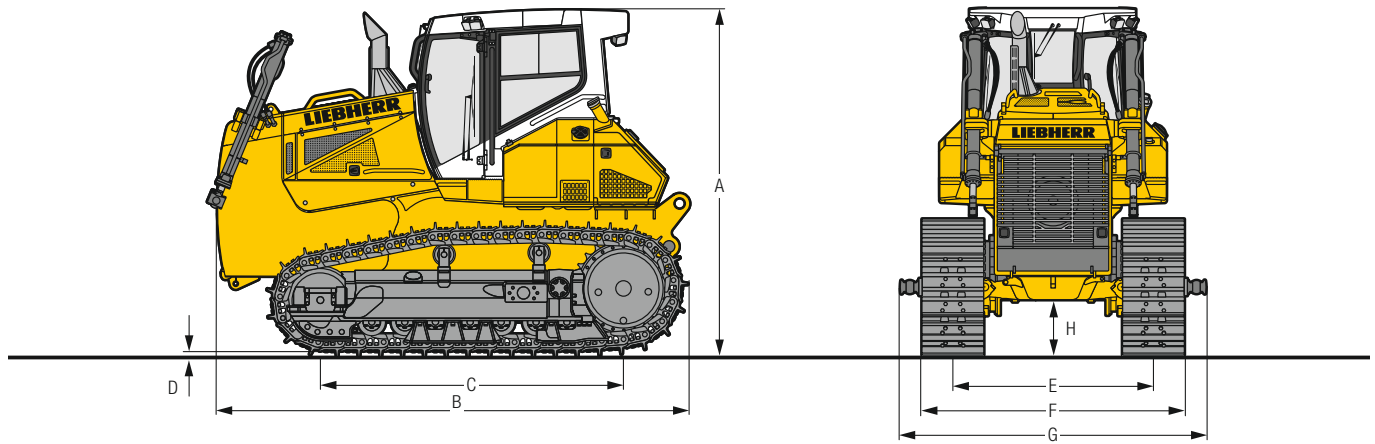

Dimensions

Undercarriage		L	LGP
A Height over cab	mm	3,435 ²⁾	3,435 ²⁾
	ft in	11'3"	11'3"
B Overall length without attachments	mm	4,671	4,671
	ft in	15'4"	15'4"
C Length of track on ground	mm	2,999	3,323
	ft in	9'10"	10'11"
D Height of grousers	mm	71.5	71.5
	ft in	2.81"	2.81"
H Ground clearance	mm	551	551
	ft in	1'10"	1'10"
E Track gauge	mm	1,980	2,180
	ft in	6'6"	7'2"
G Width over trunnions	mm	3,000	3,600
	ft in	9'10"	11'10"
F Track shoes 560 mm / 22"			
Width over tracks	mm / ft in	2,540 / 8'4"	-
Tractor shipping weight ¹⁾	kg / lb	21,644 / 47,717	-
F Track shoes 610 mm / 24"			
Width over tracks	mm / ft in	2,590 / 8'6"	-
Tractor shipping weight ¹⁾	kg / lb	21,998 / 48,497	-
F Track shoes 711 mm / 28"			
Width over tracks	mm / ft in	2,691 / 8'10"	-
Tractor shipping weight ¹⁾	kg / lb	22,705 / 50,056	-
F Track shoes 812 mm / 32"			
Width over tracks	mm / ft in	-	2,992 / 9'10"
Tractor shipping weight ¹⁾	kg / lb	-	22,769 / 50,197
F Track shoes 914 mm / 36"			
Width over tracks	mm / ft in	-	3,094 / 10'2"
Tractor shipping weight ¹⁾	kg / lb	-	23,344 / 51,465

¹⁾ Including coolant and lubricants, 20% fuel, ROPS/FOPS cab.

²⁾ Transport shipping height increases with optional equipment: preparation for Trimble & Leica +130 mm, amber beacon/beacon for back-up alarm +230 mm, dust filter overpressure system for cab +535 mm, protective cover for air conditioning condenser +170 mm, branch deflector (sweeps) +165 mm, other equipment on request.

Front attachments PR 746

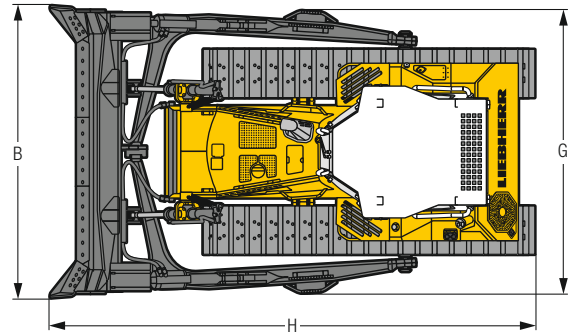
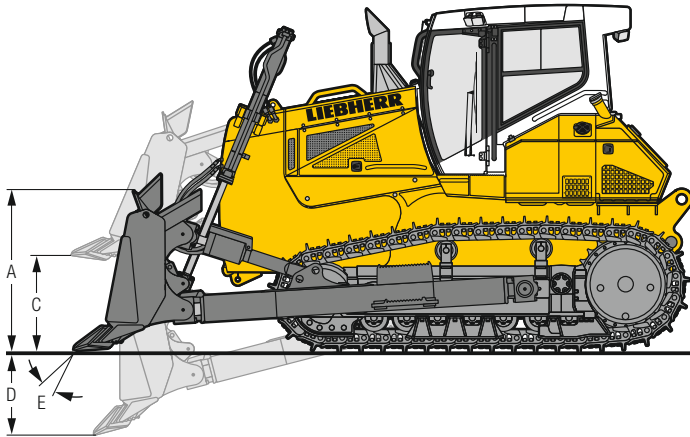

Semi-U-Blade, mechanical angle blade and straight blade

		Semi-U blade	Mechanical angle blade ²⁾	Straight blade ²⁾
Undercarriage				
Blade capacity, ISO 9246	m ³	7.20	4.33	6.00
	yd ³	9.42	5.67	7.85
A Height of blade	mm	1,544	1,130	1,320
	ft in	5'1"	3'8"	4'4"
B Width of blade	mm	3,690	4,620	4,518
	ft in	12'1"	15'2"	14'10"
Width of blade, angled	mm		4,198	
	ft in	-	3'8"	-
C Lifting height	mm	1,315	1,289	1,256
	ft in	4'1"	4'3"	4'1"
D Digging depth	mm	444	554	539
	ft in	1'5"	1'9"	1'9"
E Blade pitch adjustment		10°	-	10°
Blade angle adjustment		-	25°	-
Max. blade tilt	mm	462	672	466
	ft in	1'6"	2'2"	1'6"
G Width over push frame	mm	3,443	3,394	4,034
	ft in	11'4"	11'2"	13'3"
H Overall length, blade straight	mm	6,119	6,003	5,945
	ft in	20'1"	19'8"	19'6"
Overall length, blade angled	mm		6,919	
	ft in	-	22'8"	-
F Track shoes 560 mm / 22"				
Operating weight ¹⁾	kg / lb	25,886 / 57,069	26,018 / 57,360	-
Ground pressure, ISO16754 ¹⁾	kg/cm ² / psi	0.67 / 9.53	0.68 / 9.67	-
F Track shoes 610 mm / 24"				
Operating weight ¹⁾	kg / lb	26,240 / 57,849	26,372 / 58,140	-
Ground pressure, ISO16754 ¹⁾	kg/cm ² / psi	0.63 / 8.96	0.63 / 8.96	-
F Track shoes 711 mm / 28"				
Operating weight ¹⁾	kg / lb	26,947 / 59,408	27,079 / 59,699	-
Ground pressure, ISO16754 ¹⁾	kg/cm ² / psi	0.55 / 7.82	0.56 / 7.97	-
F Track shoes 812 mm / 32"				
Operating weight ¹⁾	kg / lb	-	-	27,257 / 60,091
Ground pressure, ISO16754 ¹⁾	kg/cm ² / psi	-	-	0.45 / 6.4
F Track shoes 914 mm / 36"				
Operating weight ¹⁾	kg / lb	-	-	27,832 / 61,359
Ground pressure, ISO16754 ¹⁾	kg/cm ² / psi	-	-	0.40 / 5.69

¹⁾ Including coolant and lubricants, 100% fuel, ROPS/FOPS cab, operator, Semi-U-, Mechanical Angle- or Straight Blade.

²⁾ Rear equipment or counterweight is recommended.

Rear attachments PR 746

1-Shank ripper

Parallelogram		hydraulic pitch adjustment	
A Ripping depth (max. / min.)	mm	829 / 499	
	ft in	2'9" / 1'8"	
B Lifting height (max. / min.)	mm	709 / 379	
	ft in	2'4" / 1'3"	
C Additional length, attachment raised	mm	1,509	
	ft in	4'11"	
D Additional length, attachment lowered	mm	1,876	
	ft in	6'2"	
E Overall beam width	mm	1,360	
	ft in	4'6"	
F Distance between shanks	mm	-	
	ft in	-	
Max. pitch adjustment		25°	
Weight	kg	2,730	
	lb	6,019	

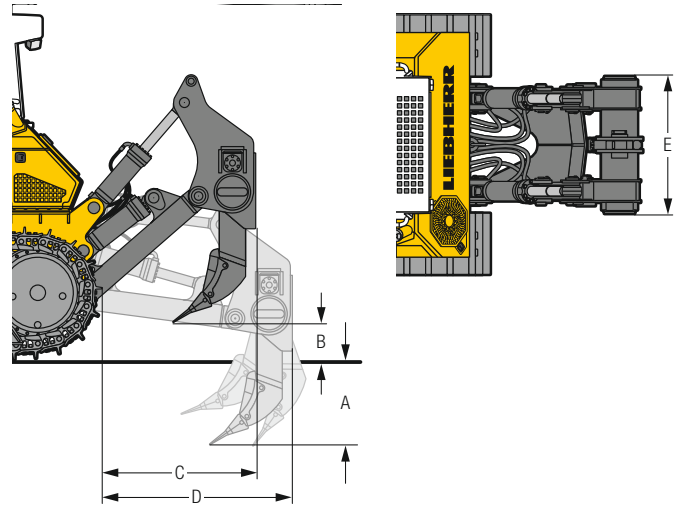

3-Shank ripper

Parallelogram		standard	hydraulic pitch adjustment
A Ripping depth (max. / min.)	mm	672 / 372	672 / 372
	ft in	2'2" / 1'3"	2'2" / 1'3"
B Lifting height (max. / min.)	mm	830 / 532	836 / 536
	ft in	2'9" / 1'9"	2'5" / 1'9"
C Additional length, attachment raised	mm	1,511	1,494
	ft in	4'11"	4'11"
D Additional length, attachment lowered	mm	1,862	1,861
	ft in	6'1"	6'1"
E Overall beam width	mm	2,184	2,184
	ft in	7'2"	7'2"
F Distance between shanks	mm	1,000	1,000
	ft in	3'3"	3'3"
Max. pitch adjustment		-	25°
Weight	kg	3,323	3,334
	lb	7,326	7,350

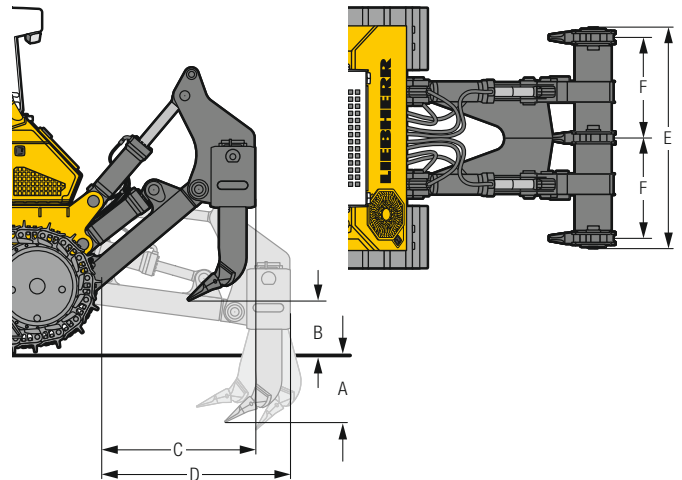

Drawbar

		rigid
A Additional length	mm	469
	ft in	1'6"
B Socket pin diameter	mm	50
	ft in	1.97"
C Height of jaw	mm	598
	ft in	2'
D Ground clearance	mm	490
	ft in	1'7"
Jaw opening	mm	95
	ft in	3.74"
Weight	kg	431
	lb	950

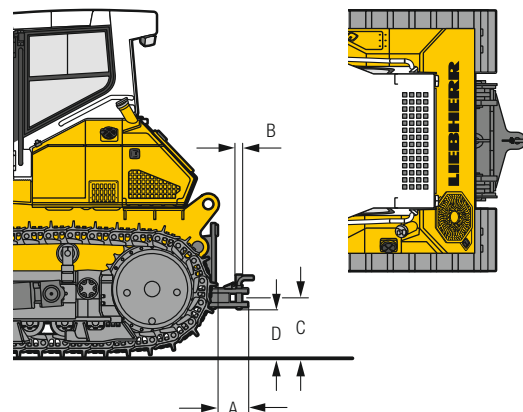

Technical data PR 756



Engine

Liebherr Diesel engine	D 946 A7 Emission regulations according to 97/68/EC, 2004/26/EG stage V / stage IIIA, EPA / CARB Tier 4f
Rated power (net) ISO 9249 SAE J1349	260 kW / 353 HP 260 kW / 349 HP
Maximum power (net) ISO 9249 SAE J1349	275 kW / 374 HP 275 kW / 369 HP
Rated speed	1,600 rpm
Displacement	12 l / 733 in ³
Design	6 cylinder in-line engine, water-cooled, turbocharged, air-to-air intercooler
Injection system	Direct fuel injection, Common Rail, electronic control
Lubrication	Pressurised lube system, engine lubrication guaranteed for inclinations up to 45°, on all sides
Operating voltage	24 V
Alternator	140 A
Starter	7.8 kW / 11 HP
Batteries	4 x 95 Ah / 12 V
Air cleaner	Dry type air filter with vacuum indicator and automatic dust ejector, main and safety element
Cooling system	Combi radiator, comprising radiators for water and charge air. Hydrostatic fan drive



Hydraulics

Hydraulic system	Load sensing (demand-controlled)
Pump type	Swash plate piston pump
Pump flow, max.	256 l/min. / 67.6 gpm / 56.3 Imp.gpm
Pressure limitation	260 bar / 3,770 psi
Control valve	2 segments, expandable to 4
Filter system	Return filter with magnetic rod in the hydraulic tank
Control	Single joystick for all blade functions



Travel drive

Transmission system	Infinitely variable hydrostatic travel drive, independent drive for each track
Travel speed* Speed range 1: Speed range 2: Speed range 3:	Continuously variable 0 - 4.0 km/h / 2.5 mph (forward & reverse) 0 - 6.0 km/h / 3.7 mph (forward & reverse) 0 - 11.0 km/h / 6.8 mph (forward & reverse) *Travel speed ranges can be set on the travel joystick (memory function)
Electronic system	The electronic system automatically adjusts travel speed and drawbar pull to match changing load conditions
Steering	Hydrostatic
Service brake	Hydrostatic (self-locking), wear-free
Parking brake	Multi-disc brake, wear-free, automatically applied with neutral joystick position
Cooling system	Separate oil cooler, hydraulic fan drive
Filter system	Micro cartridge filter in replenishing circuit
Final drive	Combination spur gear with planetary gear, double-sealed (duo cone seals) with temperature indicator
Control	Single proportional joystick for all travel and steering functions



Operator's cab

Cab	Hydro-elastic mounted cab with positive pressure ventilation, can be tilted with hand pump 40° to the rear. With integrated ROPS Rollover Protective Structure (EN ISO 3471) and FOPS Falling Objects Protective Structure (EN ISO 3449)
Operator's seat	Air suspended comfort seat, fully adjustable
Monitoring	Touch screen: display of current machine information, automatic monitoring of operating conditions, individual setting of machine parameters
Vibration emission Hand / arm vibrations Whole-body vibrations	< 2,5 m/s ² , according with ISO 5349-1:2001 0,24 - 1,31 m/s ² , complies with technical report ISO/TR 25398:2006
Measuring inaccuracy	According with standard EN 12096:1997

Undercarriage

	Standard	LGP
Design	Undercarriage with rigid bottom rollers or bogie suspension or oscillating idler	
Mounting	Via separate pivot shafts and equalizer bar	
Track chains	Lubricated, single grouser shoes, tensioning via steel spring and grease tensioner	
Links, each side	44	44
Track rollers, each side	7	7
Carrier rollers, each side	2	2
Sprocket segments, each side	5	5
Track shoes, standard	610 mm / 24"	914 mm / 3"
Track shoes, optional	560 mm / 22", 711 mm / 28"	965 mm / 3'2"

Sound levels

Operator sound exposure ISO 6396	
L_{pA} (in the cab)	75 dB(A)
Exterior sound pressure 2000 / 14 / EC	
L_{WA} (to the environment)	113 dB(A)

Refill capacities

Cooling system	55 l / 14.5 gal / 12.1 Imp.gal
Diesel Exhaust Fluid (DEF) tank	80 l / 21.1 gal / 17.6 Imp.gal
Engine oil, with filters	43 l / 11.4 gal / 9.5 Imp.gal
Final drive LGP, each side	26 l / 6.9 gal / 5.7 Imp.gal
Final drive Standard, each side	20 l / 5.3 gal / 4.4 Imp.gal
Fuel tank	660 l / 174.2 gal / 145.2 Imp.gal
Hydraulic tank	129 l / 34.1 gal / 28.4 Imp.gal
Splitter box	8.5 l / 2.2 gal / 1.9 Imp.gal

Drawbar pull

Max.	592 kN
at 1.5 km/h / 0.9 mph	522 kN
at 3.0 km/h / 1.9 mph	261 kN
at 6.0 km/h / 3.7 mph	133 kN
at 9.0 km/h / 5.6 mph	89 kN

Dimensions PR 756

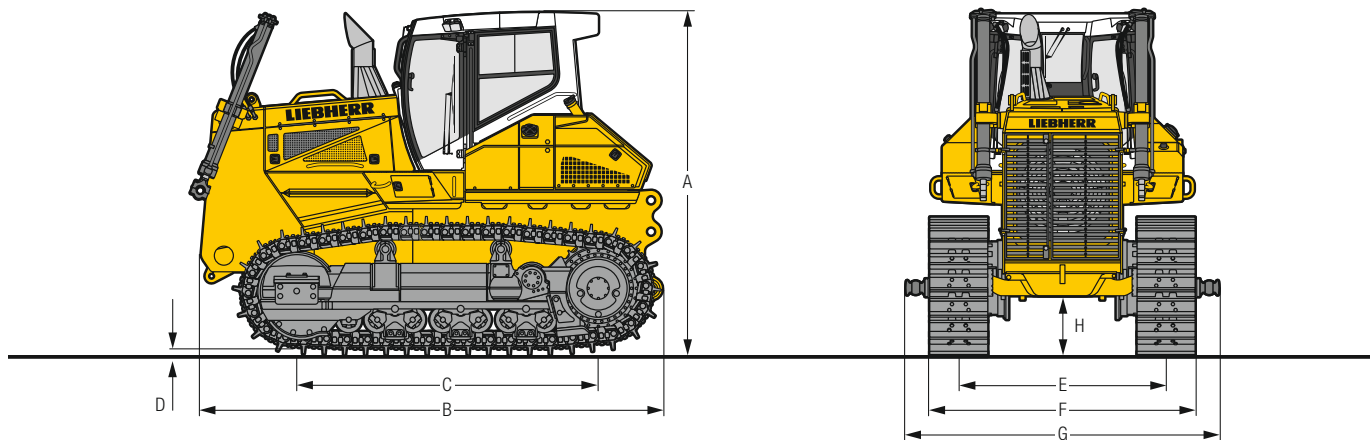

Dimensions

Undercarriage		Standard rigid bottom rollers	Standard bogie suspension	Standard oscillating idler double bogie suspension	LGP rigid bottom rollers
A Height over cab	mm ft in	3,610 ²⁾ 11'10"	3,610 ²⁾ 11'10"	3,610 ²⁾ 11'10"	3,610 ²⁾ 11'10"
B Overall length without attachments	mm ft in	4,885 16'0"	4,885 16'0"	4,885 16'0"	4,885 16'0"
C Length of track on ground	mm ft in	3,174 10'5"	3,174 10'5"	3,249 10'8"	3,174 10'5"
D Height of grousers	mm ft in	83 3.27"	83 3.27"	83 3.27"	83 3.27"
H Ground clearance	mm ft in	635 21"	644 21"	635 21"	635 21"
E Track gauge	mm ft in	2,180 7'2"	2,180 7'2"	2,180 7'2"	2,430 8'
G Width over trunnions	mm ft in	3,145 10'4"	3,145 10'4"	3,145 10'4"	3,575 11'9"
F Track shoes 560 mm / 22"					
Width over tracks	mm / ft in	2,740 / 9'	2,740 / 9'	2,740 / 9'	-
Tractor shipping weight ¹⁾	kg / lb	29,106 / 64,168	30,033 / 66,211	31,067 / 68,491	-
F Track shoes 610 mm / 24"					
Width over tracks	mm / ft in	2,790 / 9'2"	2,790 / 9'2"	2,790 / 9'2"	-
Tractor shipping weight ¹⁾	kg / lb	29,346 / 64,697	30,273 / 66,740	31,307 / 69,020	-
F Track shoes 711 mm / 28"					
Width over tracks	mm / ft in	2,891 / 9'6"	2,891 / 9'6"	2,891 / 9'6"	-
Tractor shipping weight ¹⁾	kg / lb	29,823 / 65,748	30,750 / 67,792	31,784 / 70,072	-
F Track shoes 914 mm / 3"					
Width over tracks	mm / ft in	-	-	-	3,344 / 11'
Tractor shipping weight ¹⁾	kg / lb	-	-	-	30,866 / 68,048
F Track shoes 965 mm / 3'2"					
Width over tracks	mm / ft in	-	-	-	3,395 / 11'2"
Tractor shipping weight ¹⁾	kg / lb	-	-	-	31,343 / 69,099

¹⁾ Including coolant and lubricants, 20% fuel, ROPS / FOPS cab.

²⁾ Transport shipping height increases with optional equipment: preparation for Trimble & Leica +130 mm, amber beacon/beacon for back-up alarm +230 mm, dust filter overpressure system for cab +535 mm, protective cover for air conditioning condenser +170 mm, branch deflector (sweeps) +165 mm, other equipment on request.

Front attachments PR 756

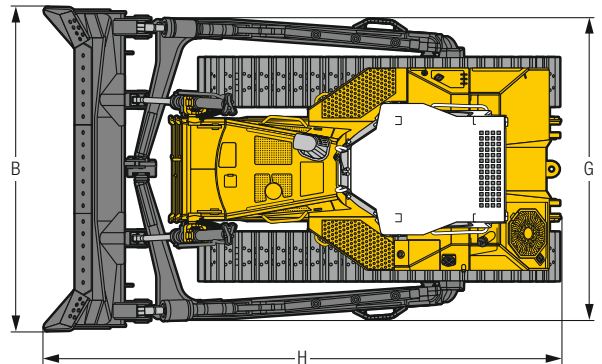
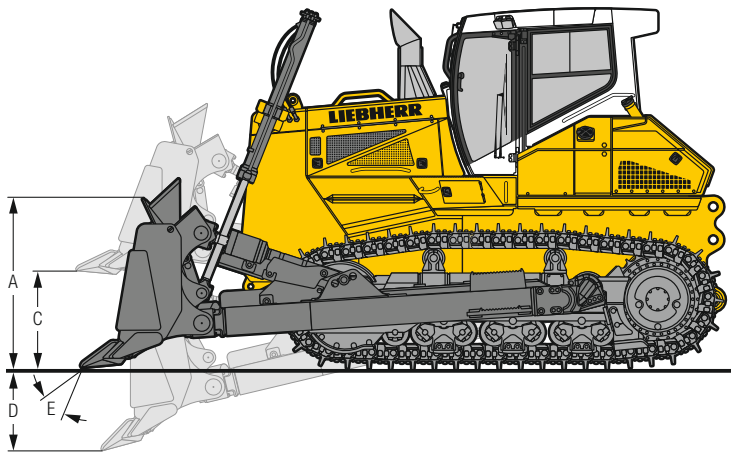

Semi-U blade

Undercarriage		Standard rigid bottom rollers	Standard bogie suspension	Standard oscillating idler double bogie suspension	LGP rigid bottom rollers
Blade capacity, ISO 9246	m ³	8.92		8.92	9.46
	yd ³	11.67		11.67	12.37
A Height of blade	mm	1,650		1,650	1,600
	ft in	5'5"		5'5"	5'3"
B Width of blade	mm	4,044		4,044	4,465
	ft in	13'3"		13'3"	14'8"
C Lifting height³⁾	mm	1,372		1,381	1,403
	ft in	4'6"		4'6"	4'7"
D Digging depth³⁾	mm	570		561	563
	ft in	1'10"		1'10"	1'10"
E Blade pitch adjustment		10°		10°	2)
Max. blade tilt	mm	993		993	481
	ft in	3'3"		1'10"	1'7"
G Width over push frame	mm	3,767		3,767	4,193
	ft in	12'4"		12'5"	13'9"
H Overall length	mm	6,449		6,449	6,452
	ft in	21'2"		21'2"	21'2"
F Track shoes 560 mm / 22"					
Operating weight ¹⁾	kg / lb	35,388 / 78,017	36,315 / 80,061	37,349 / 81,679	-
Ground pressure, ISO16754 ¹⁾	kg/cm ² / psi	0.87 / 12.37	0.89 / 12.66	0.90 / 12.8	
F Track shoes 610 mm / 24"					
Operating weight ¹⁾	kg / lb	35,628 / 78,546	36,555 / 79,928	37,589 / 78,385	-
Ground pressure, ISO16754 ¹⁾	kg/cm ² / psi	0.80 / 11.38	0.82 / 11.66	0.83 / 11.8	
F Track shoes 711 mm / 28"					
Operating weight ¹⁾	kg / lb	36,105 / 79,598	37,032 / 80,980	38,066 / 81,641	-
Ground pressure, ISO16754 ¹⁾	kg/cm ² / psi	0.70 / 9.96	0.71 / 10.1	0.72 / 10.24	
F Track shoes 914 mm / 3"					
Operating weight ¹⁾	kg / lb	-	-	-	37,170 / 81,946
Ground pressure, ISO16754 ¹⁾	kg/cm ² / psi	-	-	-	0.56 / 7.96
F Track shoes 965 mm / 3'2"					
Operating weight ¹⁾	kg / lb	-	-	-	37,410 / 82,475
Ground pressure, ISO16754 ¹⁾	kg/cm ² / psi	-	-	-	0.53 / 7.54

¹⁾ Including coolant and lubricants, 100% fuel, ROPS / FOPS cab, semi-U blade, operator.

²⁾ Mechanical blade pitch adjustment.

³⁾ The indicated dimensions include the height of the grouser shoe.

Front attachments PR 756

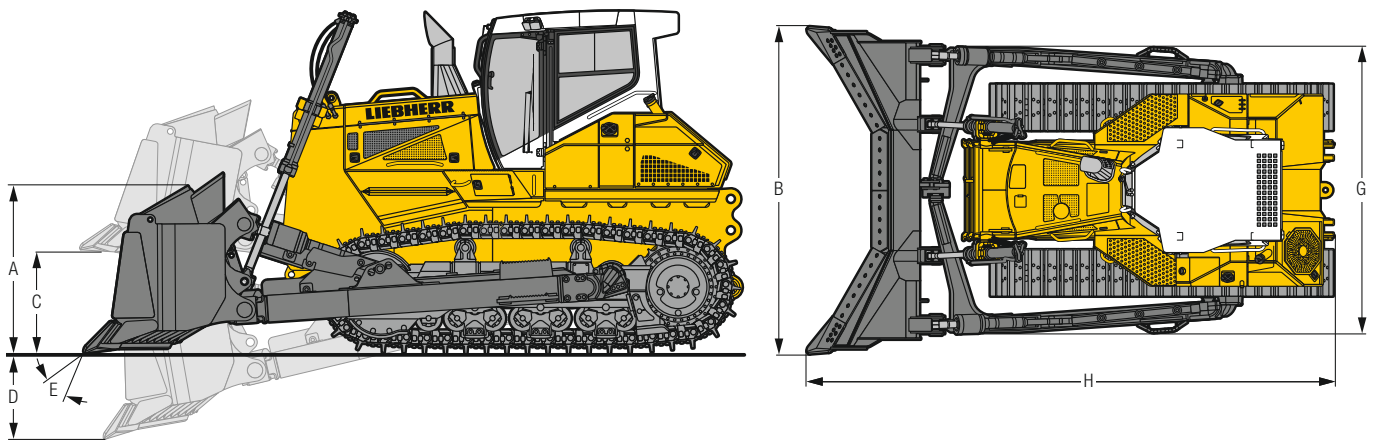

U-Blade

Undercarriage		Standard rigid bottom rollers	Standard bogie suspension	Standard oscillating idler double bogie suspension	
Blade capacity, ISO 9246	m ³		11.8	11.8	
	yd ³		15.43	15.43	
A Height of blade	mm		1,700	1,700	
	ft in		5'7"	5'7"	
B Width of blade	mm		4,281	4,281	
	ft in		14'1"	14'1"	
C Lifting height ²⁾	mm		1,361	1,370	
	ft in		4'6"	4'6"	
D Digging depth ²⁾	mm		565	556	
	ft in		1'10"	1'10"	
E Blade pitch adjustment			10°	10°	
	Max. blade tilt	mm	1,052	1,052	
	ft in		3'5"	3'5"	
G Width over push frame	mm		3,767	3,767	
	ft in		12'4"	12'4"	
H Overall length	mm		6,872	6,872	
	ft in		22'7"	22'7"	
F Track shoes 560 mm / 22"	Operating weight ¹⁾	kg / lb	35,358 / 77,951	36,285 / 79,995	37,319 / 82,274
	Ground pressure, ISO16754 ¹⁾	kg/cm ² / psi	0.87 / 12.37	0.89 / 12.66	0.90 / 12.80
F Track shoes 610 mm / 24"	Operating weight ¹⁾	kg / lb	35,598 / 78,480	36,525 / 80,524	37,559 / 82,803
	Ground pressure, ISO16754 ¹⁾	kg/cm ² / psi	0.80 / 11.38	0.82 / 11.66	0.83 / 11.80
F Track shoes 711 mm / 28"	Operating weight ¹⁾	kg / lb	36,075 / 79,532	37,002 / 81,575	38,036 / 83,855
	Ground pressure, ISO16754 ¹⁾	kg/cm ² / psi	0.68 / 9.67	0.71 / 10.1	0.72 / 10.24

¹⁾ Including coolant and lubricants, 100% fuel, ROPS/FOPS cab, U-Blade, operator.

²⁾ The indicated dimensions include the height of the grouser shoe.

Rear attachments PR 756

1-Shank ripper

Parallelogram		hydraulic pitch adjustment	
A Ripping depth (max. / min.)	mm	1,203 / 423	
	ft in	3'11" / 1'5"	
B Lifting height (max. / min.)	mm	1,040 / 260	
	ft in	3'5" / 0'10"	
C Additional length, attachment raised	mm	1,820	
	ft in	6'	
D Additional length, attachment lowered	mm	2,373	
	ft in	7'9"	
E Overall beam width	mm	1,370	
	ft in	4'6"	
F Distance between shanks	mm		
	ft in	-	
Max. pitch adjustment		31°	
Max. penetration force	kN	123.9	
	lbf	27,854	
Max. pryout force	kN	208.8	
	lbf	46,940	
Weight	kg	3,638	
	lb	8,020	

The indicated dimensions include the height of the grouser shoe.

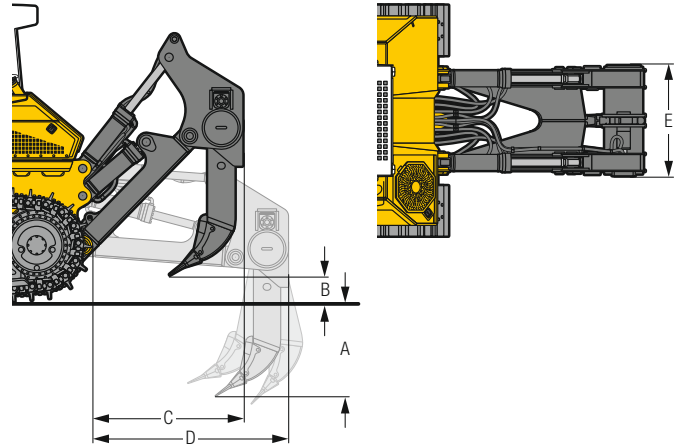

3-Shank ripper

Parallelogramm		hydraulic pitch adjustment	
A Ripping depth (max. / min.)	mm	796 / 481	
	ft in	2'7" / 1'7"	
B Lifting height (max. / min.)	mm	982 / 667	
	ft in	3'3" / 2'2"	
C Additional length, attachment raised	mm	1,820	
	ft in	6'	
D Additional length, attachment lowered	mm	2,373	
	ft in	7'9"	
E Overall beam width	mm	2,434	
	ft in	8'	
F Distance between shanks	mm	1,100	
	ft in	3'7"	
Max. pitch adjustment		31°	
Max. penetration force	kN	131.8	
	lbf	29,630	
Max. pryout force	kN	208.8	
	lbf	46,940	
Weight	kg	4,821	
	lb	10,628	

The indicated dimensions include the height of the grouser shoe.

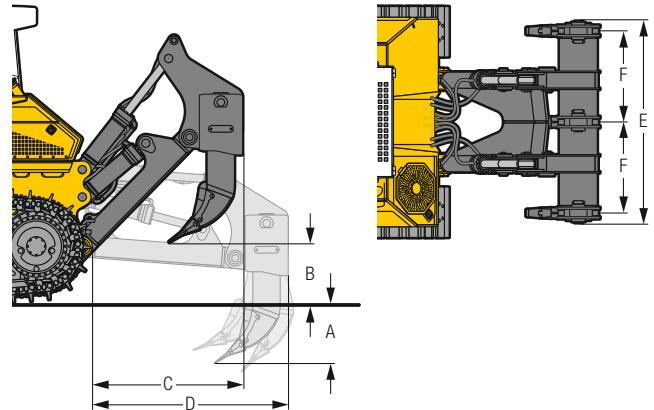

Drawbar

		rigid	
A Additional length	mm	463	
	ft in	1'6"	
B Socket pin diameter	mm	60	
	ft in	2.36"	
C Height of jaw	mm	629	
	ft in	2'1"	
D Ground clearance	mm	506	
	ft in	1'8"	
Jaw opening	mm	105	
	ft in	4.13"	
Weight	kg	576	
	lb	1,270	

The indicated dimensions include the height of the grouser shoe.

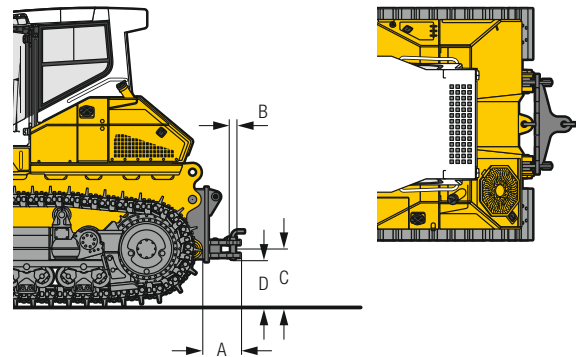

Equipment

	PR 746	PR 756
 Base machine		
Additional handle on treadplate	●	●
Air filter with automatic dust ejector	●	●
Air filter, dry type, dual step, with pre-filter	●	●
Air pre-cleaner Sy-Klone	+	+
Air pre-cleaner Top Air	+	+
Auto Idle	+	+
Automatic blade stabilization + inclination control	2)	2)
Automatic engine shut-off	+	+
Battery compartment, lockable	●	●
Coal arrangement	+	+
Cold environment arrangement	+	+
Cooling fan, front hinged	●	●
Cooling fan, hydraulically driven	●	●
Cooling fan, rear hinged	●	●
Cooling fan, reversible	+	+
DEF tank lockable	●	+
Engine compartment doors, lockable	●	●
Engine compartment lighting	●	●
Forestry arrangement	+	+
Fuel pre-filter	●	●
Fuel water separator	●	●
Fuel water separator, with electric heater	+	+
Grade control ready kit	+	+
Landfill arrangement	+	+
LiDAT – Data transmission system	●	●
Liebherr hydraulic oil, biologically degradable	+	+
Radiator guard, hinged	●	●
Radiator, wide-meshed	●	●
Refuelling pump, electric	+	+
Spade with mounting bracket	+	+
Special paint scheme	+	+
Tool kit, basic	●	●
Tool kit, extended	+	+
Towing hitch rear	●	●
Towing lug front	●	●
Woodchip arrangement	+	+

	PR 746	PR 756
 Hydraulics system		
Automatic lifting of the ripper into the parking position	●	●
Blade float function	●	●
Blade quick drop function	●	●
Blade shake feature	●	●
Electronic pilot control of the working hydraulics	●	●
Hydraulic kit for ripper	+	+
Hydraulic kit for winch	+	+
Load-Sensing control block and gear pump	●	●
Oil filter in hydraulic tank	●	●

	PR 746	PR 756
 Travel drive		
Emergency stop	●	●
Final drives planetary gear	●	●
Inching brake pedal	+	+
Load limit control, electronic	●	●
Machine-release switch	●	●
Parking brake, automatic	●	●
Seat contact switch	●	●
Travel control, 3 speed ranges	●	●
Travel drive joystick, detented	+	+
Travel drive joystick, proportional	●	●
Travel drive, hydrostatic	●	●

	PR 746	PR 756
 Operator's cab		
Access and exit step lighting	2)	2)
Armrests 3D adjustable	●	●
Automatic climate control	●	●
Cab heating	●	●
Coat hook	●	●
Dome light LED	●	●
Dust filter system pressurised	+	+
Extension of cab door footstep	+	+
Fire extinguisher	+	+
Foot support on front console	+	+
Joysticks, longitudinally adjustable	●	●
Noise-absorbing cab mounts	●	●
Operator's seat Comfort, air-suspended	●	●
Operator's seat Premium, air-suspended	+	+
Pressurised cab	●	●
Protective grid for rear window	+	+
Radio	+	+
Radio preparation kit	+	+
Rear-view camera	+	+
Rear-view mirror, inside	●	●
Rear-view mirrors, external	+	+
ROPS / FOPS integrated	●	●
Safety glass	●	●
Sliding window left	+	+
Sliding window right	+	+
Socket 12V + 24V	●	●
Storage nets	+	+
Stowage compartment, air-conditioned	●	●
Sun visor, front	+	+
Tilttable cab	●	●
Touch-controlled colour display	●	●
Windshield washer system	●	●
Windshield wipers front, rear, doors, with intermittent function	●	●

● = Standard

+ = Option

- = not available

2) Standard for stage V / Tier 4f, Optional for stage IIIA

Equipment

 Electrical system	PR 746	PR 756
	1 additional working light on each lift cylinder	+
1 additional working light on ripper	-	+
1 working light on each lift cylinder	●	●
2 additional working light on the cab, rear	+	+
2 batteries cold start	●	●
2 working lights on the cab, rear	●	●
4 working light on the cab, front	●	●
All working lights in LED version	+	+
Back-up alarm with broadband signal	+	+
Back-up alarm with broadband signal and visual	+	+
Back-up alarm, acoustic	+	+
Back-up alarm, acoustic and visual	+	+
Battery main switch	●	●
Battery main switch, lockable	+	+
Beacon	+	+
Horn	●	●
Immobiliser, electronic	+	+
On-board voltage 24 V	●	●

 Undercarriage	PR 746	PR 756
	Master link, two-piece	●
Sprocket segments with recesses	+	●
Sprocket segments, bolted	●	●
Track frame, closed	●	●
Track guard, full length	+	+
Track guide centre part	+	+
Track guide, front and rear	●	●
Track pads with mud holes ²⁾	+	+
Tracks, oil-lubricated	●	●
Undercarriage L	+	-
Undercarriage LGP	+	+
Undercarriage Standard	-	+
Undercarriage with bogie suspension	-	+
Undercarriage with double bogie suspension and oscillating idlers	-	+
Undercarriage with rigid bottom rollers	●	●

 Attachments front	PR 746	PR 756
	Hydraulic pitch angle adjustment	+
Mechanical angle blade	+	+
Semi-U blade	+	+
Spill plate	+	+
Straight blade	+	-
Trash rack	+	+
U blade	1)	+
Wear plates on push frame	+	+
Wear plates on semi-U blade	+	+

 Attachments rear	PR 746	PR 756
	Counterweight, rear (3,200 kg / 7,055 lb / 4,000 kg / 8,818 lb)	+
Drawbar rear, rigid	+	+
Mounting plate for third-party equipment	+	+
Ripper, 1 shank	+	+
Ripper, 1 shank with pin puller	-	+
Ripper, 3 shank	+	+
Winch	+	+

- = Standard
- + = Option
- = not available
- 1) on demand at your dealer
- 2) available track shoes on demand at your dealer

Options and/or special attachments, supplied by vendors other than Liebherr, are only to be installed with the knowledge and approval of Liebherr in order to retain warranty.

 **WARNING**

Breathing diesel engine exhaust exposes you to chemicals known to the State of California to cause cancer and birth defects or other reproductive harm.

- Always start and operate the engine in a well-ventilated area.
- If in an enclosed area, vent the exhaust to the outside.
- Do not modify or tamper with exhaust system.
- Do not idle the engine except as necessary.

For more information go to www.P65warnings.ca.gov/diesel.

 **WARNING**

This product can expose you to chemicals including lead and lead compounds, which are known to the State of California to cause cancer and birth defects or other reproductive harm.

For more information go to www.P65warnings.ca.gov.

Liebherr-Werk Telfs GmbH

Hans-Liebherr-Straße 35 • 6410 Telfs, Austria • Phone +43 50809 6-100 • Fax +43 50809 6-7772
 lwt.marketing@liebherr.com • www.liebherr.com • www.facebook.com/LiebherrConstruction