A 920 Litronic

LIEBHERR

Wheeled excavator



Generation
6

Engine
129 kW / 175 HP
Stufe V
Tier 4 Final

Operating weight
18,300–21,900 kg

Bucket capacity
0.55–1.20 m³

Performance

Robustly stable power, strength and precision

Economy

A sound investment – optimum economy and environmentally friendly

Reliability

Competence, consistency, innovation – proven experience

Comfort

Ergonomic excellence – superior cabin design for operator comfort and wellbeing

Maintainability

Service every step of the way – simple, fast and reliable

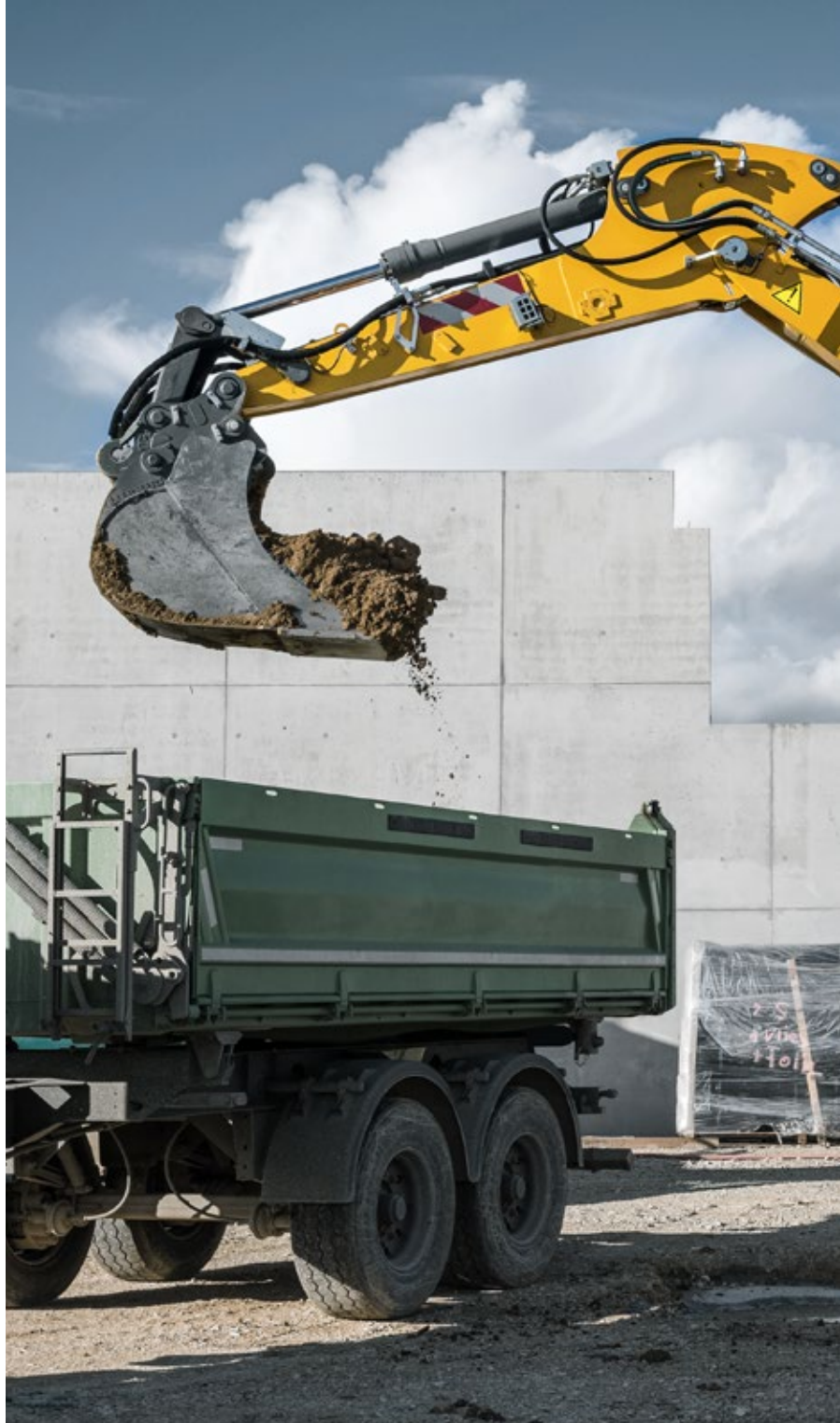



A 920 Litronic

Operating weight

18,300–21,900 kg

Engine

129 kW / 175 HP

Stage V

Tier 4 Final

Bucket capacity

0.55–1.20 m³

Performance



Robustly stable power, strength and precision

Liebherr wheeled excavators are designed for maximum productivity. Large grab capacity, high payloads and rapid working cycles satisfy all the requirements for efficient site operations. A wide range of equipment versions enhances excavator use.

Maximum performance

Versatile & strong

Through its productivity and efficiency, the powerful Liebherr A 920 excels in all fields of application. Its machine concept is ideally suited to road, canal and pipeline construction as well as to conventional earthmoving work. The A 920's range of applications can be further extended thanks to a wide variety of optional equipment. This makes the machine a powerful and cost-effective all-rounder that improves capacity and significantly boosts productivity.

Working faster

Many years of experience in the development and production of hydraulic excavators and systems allow us to harmonise the components perfectly. As a result, Liebherr hydraulic excavators feature rapid, fluid movements combined with high precision. These properties are also available when simply driving the machine. The speed and precision of the machine can be adjusted using the MODE switch to suit a new task, which also saves fuel.

Precise work

Working with precision

The Liebherr joysticks enable the operator to intuitively and sensitively control the Liebherr hydraulic system to complete even the most challenging tasks quickly, not only with reduced speed but also with maximum power output. This means the machine operator can carry out the most challenging tasks in a short time, not only at reduced speed but also with maximum performance output from the machine. Liebherr has been using an infinitely variable proportional controller with four axes for many years. The slim, ergonomically designed proportional sensors deliver additional functionality to the classic machine controller without having to reach for additional controls. Typical functions include high and medium pressure movements for attachments, the control of height and sideways-adjustable booms as well as lowering the machine outrigger. The mini-joysticks can also be used optionally to steer the entire machine. Buttons on the joysticks, which the operator can configure, deliver additional convenience and functions.



Constant power

- Powerful and robust construction machinery motor for continuous use at full load
- 4.5 l long-stroke engine for high torque and fuel-efficient work at low speeds
- Efficient turbo loader with inter-cooling - high output at low fuel consumption



Digging force

- High digging and breakout force
- Continuously high digging performance even in tough ground
- More digging force for faster results



The perfect attachment for any use

- Large selection of different attachments
- Careful and precise coordination of bucket shape and tooth design for the required application
- Liebherr attachments are developed and manufactured in-house. A well-thought-out choice of materials, special heat treatment and the lowest production tolerances ensure exceptional robustness and a long service life

Economy



A sound investment – optimum economy and environmentally friendly

Liebherr wheeled excavators combine high productivity and flexibility with economy in factory-standard configurations. On request, the efficiency of each wheeled excavator can be further boosted with a Liebherr productive bucket, fuel-saving Liebherr hydraulic oil or a Liebherr quick coupling system, resulting in more return from each machine operator hour.

Maximum efficiency

Strong construction machinery engine

For the A 920 Litronic, Liebherr uses a sturdy four-cylinder inline engine designed for maximum performance at all times. Intensive long-term tests have proved the resilience and quality of the installed components. The engines fulfil our high quality standards, even in the toughest working conditions. This enables reliable service over the entire life-time of the machine. Consistently powerful machines boost productivity.

Fuel efficiency and exhaust emissions treatment

The robust D924 diesel engine complies with the stringent emissions regulations of Stage V / Tier 4 Final and protects the environment as well as its resources through its low fuel consumption and reduced emissions. Liebherr uses SCRonly technology to comply with Tier 4 Final regulations. A new SCR (selective catalytic reduction) system with an integral particulate filter is used for emissions Stage V. Both systems reduce emissions effectively and do not result in any reduction in power.

Increased productivity

Immediately ready for use

Optional electrical preheating of coolant, hydraulic oil and fuel shortens the warm-up phase for the machine dramatically. This ensures a reliable and gentle engine start even at low temperatures. You can now say goodbye to temporary machine downtimes due to clogged diesel.

Efficient management

LiDAT, Liebherr's own data transmission and positioning system, facilitates efficient management, monitoring and control of the entire fleet in terms of machinery data recording, data analysis, fleet management and service. All of the important machinery data can be viewed at any time in a web browser. LiDAT provides you comprehensive work deployment documentation, greater availability thanks to shorter downtimes, faster support from the manufacturer, quicker detection of strain / overload and subsequently a longer service life of the machine as well as greater planning efficiency.

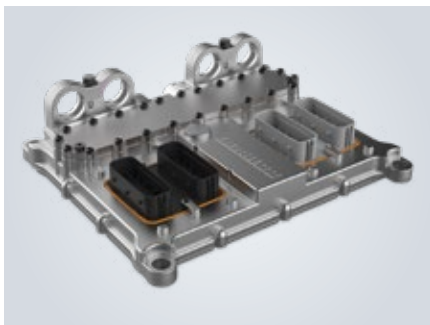

Liebherr Power Efficiency (LPE) System

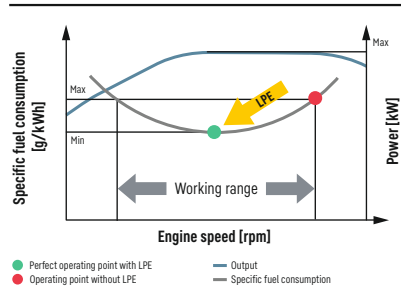

Controlled maximum power

- The engine control unit has been specially developed for Common-Rail injection systems
- All engine functions are continuously managed by the control unit, resulting in a smooth interaction between hardware and software
- The engine control unit contains diverse diagnostics programmes, thereby ensuring an increased engine service life

Low fuel consumption thanks to intelligent machine control

- Liebherr-Power Efficiency (LPE) optimises the interaction of the drive components in terms of efficiency
- LPE enables machine operation in the area of the lowest specific fuel use for less consumption and greater efficiency with the same performance

Liebherr quick coupling system Solidlink

- Faster and safer changing of mechanical and hydraulic attachments from the operator's cab
- Machine utilisation increased to up to 90% thanks to extended deployment options
- Visual and acoustic check of correct locking position of attachment at quick coupling system by two proximity sensors

Reliability



Competence, consistency, innovation – proven experience

Reliability offers safety. Safety that significantly influences the success of a project. Whatever the weather, Liebherr stands for safety – with reliable construction machines and customer-oriented sales and service partners. This means a Liebherr construction machine is exactly what it should be: an investment that pays off.

High machine availability

Quality and competence

Our product experience, our understanding of technical design and feedback from customers, sales and service form the basis for the use of pioneering ideas and have always been an integral part of our recipe for success. In addition, Liebherr has been delivering great production depth and system solutions for decades. Key components such as electronic components, slewing ring, slewing drive and hydraulic cylinders are developed and manufactured inhouse. Our great production depth guarantees the highest quality possible and allows the components to be coordinated perfectly.

Robust construction

All steel components are designed and manufactured by Liebherr. High strength steel sheets designed to withstand the harshest requirements guarantee high torsion resistance and excellent absorption of forces to ensure a long service life.

Wear minimisation

Continuous filtration of the hydraulic oil via an optional external bypass filter provides extra protection for hydraulic components while minimising wear. This also extends the service life of the hydraulic oil.

More safety

Safety

In addition to the performance and economy of a wheeled excavator, the other main focus is on the safety of personnel and the machine. A wide range of equipment such as pipe fracture safety devices on lifting and stick cylinders, load holding valves on outriggers, lift limitation in height, overload warning device, roll-over protection system (ROPS) and the emergency exit through the rear window deliver maximum safety for every job.

Maximum stability

Various undercarriage versions with securely welded outriggers deliver safe footing, maximum stability and a long service life. The stabilizer blade as well as the outriggers have been designed for the toughest scenarios, allowing the machine to reliably carry out its work at full load.



QPDM – Quality and process data management

- QPDM allows production data to be logged, documented and evaluated
- Automation of documentation and test specifications
- Ability to handle large quantities and maintain uniform high quality

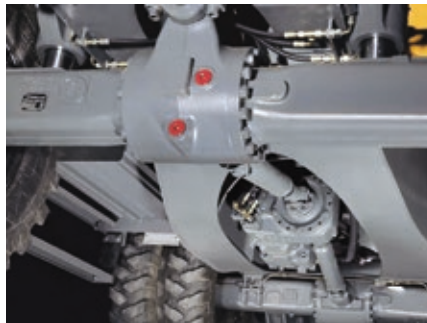

Effective undercarriage concept

- Liebherr undercarriages provide the best stability, greater lifting power and high levels of driving comfort thanks to their long wheel base and optimal weight distribution
- An oscillating axle as standard ensures stability in all positions
- To prevent damage to the travel drive, all components on the undercarriage with a stabilizer blade are installed in the sturdy undercarriage frame



Liebherr twin tyres EM 22 without intermediate ring

- Specially developed twin tyres for increased stability when not supported
- Long service life through increased wear resistance
- Best traction on soft and sandy terrain
- Unique in its class: The dimensions correspond to the 10-set twin tyres and do not exceed the permissible width

Comfort



Ergonomic excellence – superior cabin design for operator comfort and wellbeing

The Liebherr excavator cab comes with generous dimensions and an ergonomic design. The operator's seat is individually adjustable, the control panel is arranged clearly and helpfully and the all-round visibility is perfect. Automatic air-conditioning ensures the right temperature at all times in the "Liebherr feel-good cab".

First-class cab

Productive working environment

The spacious Liebherr cab offers plenty of room for long working days and ensures the best platform for all-round visibility thanks to large window areas and narrow bars. All gear levers and control panels are located within reach and fit the ergonomic concept of the operator's cab perfectly. The temperature, fan setting and the standard automatic air-conditioning's head, chest and foot level air vents can be adjusted with ease using touchscreen control.

Operator seats

The Standard, Comfort and Premium operator's seat versions deliver maximum comfort. Even the Standard operator's seat has been manufactured with high-quality materials and has an extensive selection of standard equipment including pneumatic suspension, seat heating, headrest, lumbar support and much more. A luxury which we believe every construction machine should provide.

Smooth operation

The use of visco-elastic mounts, good noise insulation and modern, smooth diesel engines minimise noise emissions and vibrations.

Comfortable operation

Radio with hands-free device

The optional Liebherr radio is MP3-compatible, has a USB connection, can receive digital radio (DAB+ depending on country) and can be used as interface for the integral hands-free kit. If a smartphone is connected using Bluetooth, phone calls can also be controlled via the touchscreen. This means that all media are controlled using a central unit which provides greater clarity, simplicity and comfort.

Control unit

The large touchscreen provides the operator with a fast, uncomplicated interface which delivers all the information required for working with the machine. A flat, intuitive menu system ensures that it can be readily understood so that the control unit can be used in a highly productive way.

Pleasant climate

The use of an efficient auxiliary heater significantly enhances cab comfort, productive work time and safety. The upstream warm-up phase also protects the engine components and reduces wear.



Refuelling

- Using the optional refuelling pump, the machine can be refuelled directly from a fuel container
- An integral tank hose and an automatic shut off when the tank is full deliver greater comfort and short refuelling times
- Topping up – simple, quick and safe



Sliding two-piece windscreen

- Unrestricted view of the working area by sliding in the windscreen
- Simple mechanism for rapid and intuitive opening
- Windscreen can be split in two



Intuitive operation

- Display of the machine data and camera image on the 9-inch indicating unit with touchscreen and direct access via menu bar
- 20 user-programmable memory slots for attachments, which can be used for quickly and easily setting the oil pressure and oil flow at the push of a button when changing attachments
- Rear and side area monitoring provide optimum visibility of the working area at all times; equipped as standard

Maintainability



Service every step of the way – simple, fast and reliable

Liebherr wheeled excavators are not only powerful, robust, precise and efficient, they also impress with the service-orientated machine design. Maintenance is performed quickly, simply and safely. This reduces maintenance costs and keeps machine downtimes to a minimum.

Simplified maintenance concept

Service-based machine design

The service-based machine design guarantees short servicing times, thus minimising maintenance costs due to less downtime. All the maintenance points are easily accessible from the ground and easy to reach due to the large, wide-opening service doors. The enhanced service concept places the maintenance points close to each other and reduces their number to a minimum.

Hydraulic oils with added value

Liebherr hydraulic oils achieve a service life of 6,000 operating hours plus. Instead of having defined change intervals, the results of the oil analysis (every 1,000 operating hours or after one year) determine when the oil needs to be changed. The unique Liebherr Hydraulic Plus oil can even achieve a service life of 8,000 operating hours plus at the same time as reducing fuel consumption by up to 5%.

Retrofitting with new technologies

New emission standards, amended safety regulations or different areas of deployment – the demands on your machine can change as years go by. Protective grilles, additional filter systems and options for hydraulics are just a small selection from the Liebherr retrofit program with which we offer you an effective way to modify or retrofit your machine.



Lubrication during operation

- Fully automatic central lubrication system for the equipment and swing ring
- Can be expanded to the connecting link and quick coupler
- Lubrication without interrupting work for higher productivity



Excellent service access

- Large, wide-opening service doors
- Engine oil, fuel, air and cab air filters are easily and safely accessible from the ground
- The oil level in the hydraulic tank can be checked from the cab
- Standard magnetic rod in the hydraulic tank as reliable service indicator

Your competent service partner

Remanufacturing

The Liebherr remanufacturing program offers cost-effective reconditioning of components to the highest quality standards. Various reconditioning levels are available including replacement components and general overhaul or repair. The customer receives components with original part quality at a reduced cost.

Competent advice and service

Competent advice is a given at Liebherr. Experienced specialists provide advice for your specific requirements: application-oriented sales support, service agreements, cost effective repair alternatives, original parts management, as well as remote data transmission for machine planning and fleet management.



Rapid spare parts service

- 24-hour delivery: Spare parts service is available for our dealers around the clock
- Electronic spare parts catalogue: Fast and reliable selection and ordering via the Liebherr online portal
- With online tracking, the current processing status of your order can be viewed at any time

Wheeled excavator

A 920 Litronic overview

Excellent machine concept for maximum reliability

- Robust design made of high strength steel
- Various welded outrigger versions available
- Load holding valves on all outriggers
- Liebherr hydraulic cylinders with standard pipe fracture safety devices for lifting and stick cylinders
- Overload warning device
- Roll-over protection system (ROPS)
- Electronic lift limitation (optional)
- Integral travel drive protection
- Liebherr twin tyres without intermediate ring (optional)

Superior technology for highest economy

- Diesel engine with up to date emissions Stage V and Tier 4 Final
- Emissions treatment with Liebherr-SCR technology (Stage V) / Liebherr-SCR technology (Stage Tier 4 Final)
- Liebherr-Power-Efficiency (LPE) – Liebherr’s smart engine controller
- Sensor-controlled automatic idling system
- Load-sensing-control
- Liebherr quick coupling system Solidlink
- LiDAT – Liebherr’s information system for the efficient management and evaluation of the fleet

Simplified maintenance concept for maximum productivity

- Service-enhanced machine structure with easy access to the maintenance points
- Fully automatic central lubrication system for uppercarriage, slewing ring and equipment
- Liebherr Hydraulic Plus – oil with an extended service life of up to 8,000 operating hours
- Highly qualified, experienced trained personnel provide competent care
- 24 / 7 Spare parts service with 24 hour deliveries





Ergonomic operator's work station for maximum comfort

- High quality operator's seats in a range of versions
- Control console connected to the seat and ergonomic joysticks
- Folding control console, left
- Joystick steering (optional)
- Proportional control with 4-way mini-joystick
- Automatic air-conditioning system
- 9" high resolution colour display with touch-screen operation
- Rear and side monitor
- Convenient radio control with hands-free kit
- Tool Control for attachments
- LED headlights (optional)
- Large windows
- Sliding two-piece windscreen

Perfect combination for highest possible performance

- Powerful 4-cylinder in-line engine with Common-Rail injection system
- Liebherr hydraulic system for high digging and breakout forces with combined, fluid movements
- Flexible configuration of the machine with various equipment and attachment versions and options
- Equipment for large reach depths of up to 18 m (optional)
- Wide undercarriage measuring 2.75 m (optional)

Technical data



Diesel engine

Rating per ISO 9249	129 kW (175 HP) at 1,800 RPM*
Model	D924 - FPT motor designed for Liebherr
Type	4 cylinder in-line
Bore / Stroke	104 / 132 mm
Displacement	4.5 l
Engine operation	4-stroke diesel Common-Rail Turbo-charged and after-cooled Reduced emissions
Air cleaner	Dry-type air cleaner with pre-cleaner, primary and safety elements
Engine idling	Sensor controlled
Electrical system	
Voltage	24 V
Batteries	2 x 135 Ah / 12 V
Alternator	Three-phase current 28 V / 140 A
Stage V	
Harmful emissions values	According to regulation (EU) 2016/1628
Emission control	Liebherr-SCRT technology
Fuel tank	368 l
Urea tank	46 l
Tier 4 Final	
Harmful emissions values	In accordance with 40CFR1039 (EPA) / 13CCR (CARB)
Emission control	Liebherr-SCR technology
Fuel tank	368 l
Urea tank	46 l



Cooling system

Diesel engine	Water-cooled Compact cooling system consisting cooling unit for water, hydraulic oil and charge air with stepless thermostatically controlled fan, fans for radiator cleaning can be completely folded away
----------------------	--



Hydraulic controls

Power distribution	Via control valves with integrated safety valves, simultaneous and independent actuation of chassis, swing drive and equipment
Servo circuit	
Equipment and swing	With hydraulic pilot control and proportional joystick levers
Chassis	Electro-proportional via foot pedal
Additional functions	Via switch or electro-proportional foot pedals
Proportional control	Proportionally acting transmitters on the joysticks for additional hydraulic functions



Hydraulic system

Hydraulic pump	Liebherr axial piston variable displacement pump
For equipment and travel drive	Liebherr axial piston variable displacement pump
Max. flow	400 l/min.
Max. pressure	350 bar
Hydraulic pump regulation and control	Liebherr-Synchron-Comfort-system (LSC) with electronic engine speed sensing regulation, pressure and flow compensation, torque controlled swing drive priority
Hydraulic tank	160 l
Hydraulic system	max. 350 l
Filtration	1 main return filter with integrated partial micro filtration (5 µm)
MODE selection	Adjustment of engine and hydraulic performance via a mode pre-selector to match application, e.g. for especially economical and environmentally friendly operation or for maximum digging performance and heavy-duty jobs
S (Sensitive)	Mode for precision work and lifting through very sensitive movements
E (Eco)	Mode for especially economical and environmentally friendly operation
P (Power)	Mode for high performance with low fuel consumption
P+ (Power-Plus)	Mode for highest performance and for very heavy duty applications, suitable for continuous operation
Engine speed and performance setting	Stepless alignment of engine output and hydraulic power via engine speed
Option	Tool Control** : 20 pre-adjustable pump flows and pressures for add-on attachments



Swing drive

Drive	Liebherr axial piston motor with integrated brake valve and torque control, Liebherr planetary reduction gear
Swing ring	Liebherr, sealed race ball bearing swing ring, internal teeth
Swing speed	0-10.0 RPM stepless
Swing torque	54 kNm
Holding brake	Wet multi-disc (spring applied, pressure released)
Option	Pedal controlled positioning swing brake Slewing gear brake Comfort

* engine speed for road travel max. 1,900 RPM

** standard for all hydraulic excavators with high pressure circuit

Cab

Cab	ROPS safety cab structure (roll-over protection system) with individual windscreens or featuring a slide-in sub-part under the ceiling, work headlights integrated in the ceiling, a door with a sliding window (can be opened on both sides), large stowing and depositing possibilities, shock-absorbing suspension, sound damping insulating, tinted laminated safety glass, separate window shades for the sunroof window and windscreen
Operator's seat Standard	Air cushioned operator's seat with 3D-adjustable arm-rests, headrest, lap belt, seat heater, manual weight adjustment, adjustable seat cushion inclination and length and mechanical lumbar vertebrae support
Operator's seat Comfort (Option)	In addition to operator's seat standard: lockable horizontal suspension, automatic weight adjustment, adjustable suspension stiffness, pneumatic lumbar vertebrae support and passive seat climatisation with active coal
Operator's seat Premium (Option)	In addition to operator's seat comfort: active electronic weight adjustment (automatic readjustment), pneumatic low frequency suspension and active seat climatisation with active coal and ventilator
Arm consoles	Joysticks with control consoles and swivel seat, folding left control console
Operation and displays	Large high-resolution operating unit, self-explanatory, colour display with touchscreen, video-compatible, numerous setting, control and monitoring options, e.g. air conditioning control, fuel consumption, machine and attachment parameters
Air-conditioning	Automatic air-conditioning, recirculated air function, fast de-icing and demisting at the press of a button, air vents can be operated via a menu; recirculated air and fresh air filters can be easily replaced and are accessible from the outside; heating-cooling unit, designed for extreme outside temperatures, sensors for solar radiation, inside and outside temperatures (country-dependent)
Refrigerant	R134a
Global warming potential	1,430
Quantity at 25 °C	1,300g
CO ₂ equivalent	1.859t
Vibration emission*	
Hand / arm vibrations	< 2.5 m/s ²
Whole-body vibrations	< 0.5 m/s ²
Measuring inaccuracy	According with standard EN 12096:1997

Undercarriage

Drive	Oversized two speed power shift transmission with additional creeper speed, Liebherr axial piston motor with functional brake valve on both sides
Pulling force	127 kN
Travel speed	0- 3.5 km/h stepless (creeper speed off-road) 0- 7.0 km/h stepless (off-road) 0-13.0 km/h stepless (creeper speed on-road) 0-20.0 km/h stepless (road travel) 0-max. 25.0 or 37.0 km/h Speeder (option)**
Driving operation	Automotive driving using accelerator pedal, cruise control function: storage of variable accelerator pedal positions, both off-road and on-road
Axles	Manual or automatic hydraulically controlled front axle oscillation lock
Service brake	Two circuit travel brake system with accumulator; wet and backlash-free disc brake
Automatic digging brake	Works automatically when driving off (accelerator pedal actuation) and when the machine is stationary (engagement); the digging brake engages automatically - can be coupled with automatic swing axle lock
Holding brake	Wet multi-disc (spring applied, pressure released)
Stabilization	Rear stabilizer blade (adjustable during travel for dozing) Rear stabilizer blade + front outriggers Rear outriggers + front stabilizer blade Rear + front outriggers
Option	EW undercarriage 2.75 m / 9'

Equipment

Type	High-strength steel plates at highly-stressed points for the toughest requirements. Complex and stable mountings of equipment and cylinders
Hydraulic cylinders	Liebherr cylinders with special sealing and guide system and, depending on cylinder type, shock absorption
Bearings	Sealed, low maintenance

Complete machine

Lubrication	Liebherr central lubrication system for uppercarriage and equipment, automatically
Noise emission	
ISO 6396	71 dB(A) = L _{pA} (inside cab)
2000/14/EC	101 dB(A) = L _{WA} (surround noise)

* for risk assessment according to 2002/44/EC see ISO/TR 25398:2006

** country-dependent

Dimensions

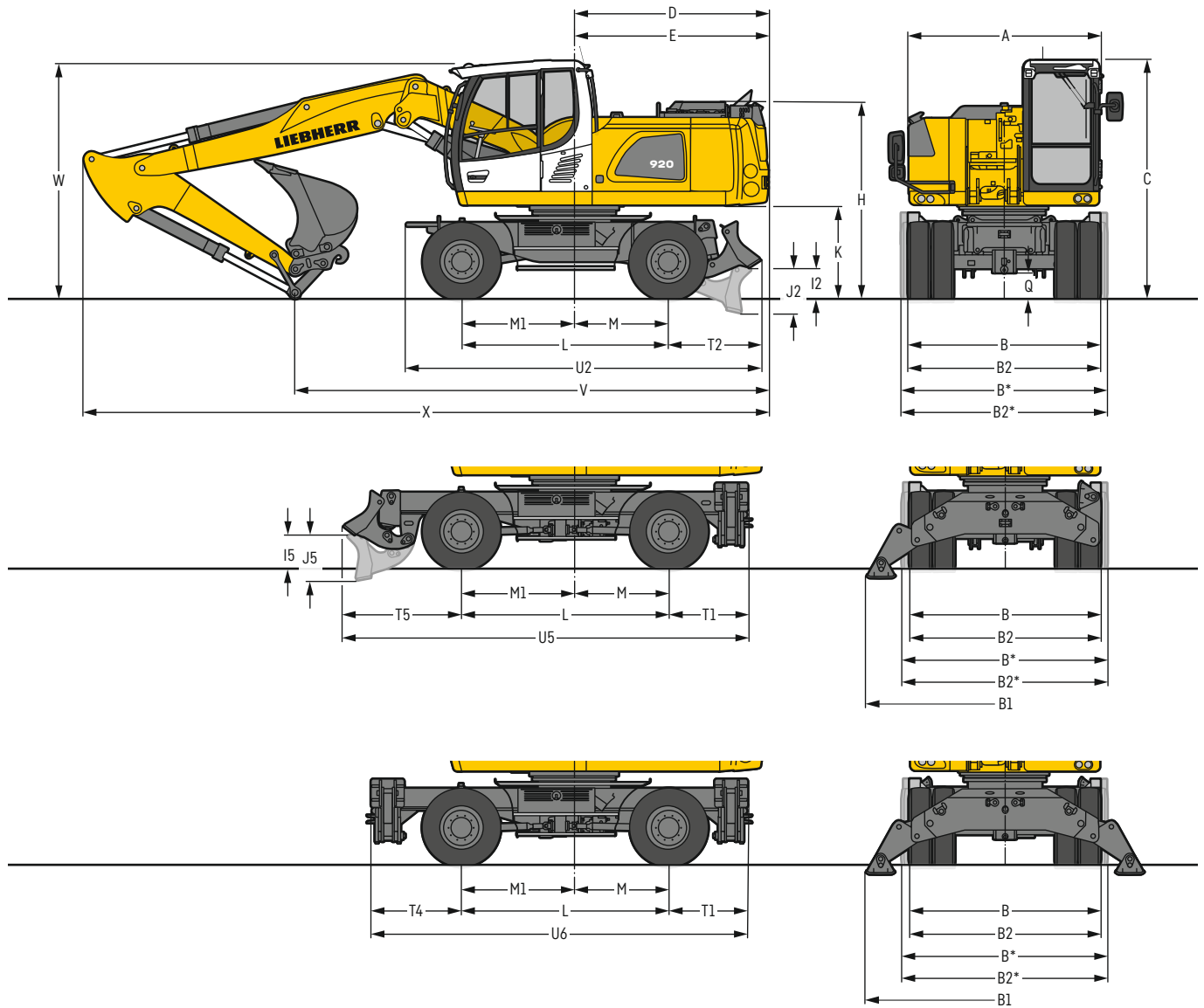

	mm
A	2,525
B	2,550
B*	2,750
B1	3,710
B2	2,550
B2*	2,750
C	3,150 / 3,160 ¹⁾
D	2,580
E	2,580
H	2,595 / 2,610 ¹⁾
I2	420
I5	450
J2	605
J5	590
K	1,215 / 1,230 ¹⁾
L	2,750
M	1,250
M1	1,500
Q	340 / 350 ¹⁾
T1	1,040
T2	1,230
T4	1,190
T5	1,560
U2	4,720
U5	5,350
U6	4,980

* EW undercarriage

¹⁾ Undercarriage version stabilizer blade rear

E = Tail radius

Tyres 10.00-20

	Stick	Two-piece boom 5.40 m			Mono boom 5.60 m		
		Rear blade	Rear outriggers + front blade	Rear + front outriggers	Rear blade	Rear outriggers + front blade	Rear + front outriggers
	m	mm	mm	mm	mm	mm	mm
V	2.25	6,700	6,700	6,700	6,650	6,650	6,650
	2.45	6,300	6,350	6,350	6,350	6,350	6,350
	2.65	6,200	6,700*	6,200	6,250	6,250	6,250
W	3.05	5,750	6,250*	5,950*	5,700	6,200*	5,900*
	2.25	3,150	3,150	3,150	3,300	3,300	3,300
	2.45	3,150	3,150	3,150	3,300	3,300	3,300
X	2.65	3,200	3,200*	3,200	3,350	3,350	3,350
	3.05	3,200	3,200*	3,200*	3,350	3,350*	3,350*
	2.25	9,100	9,100	9,100	9,250	9,250	9,250
	2.45	9,150	9,150	9,150	9,250	9,250	9,250
	2.65	9,150	9,600*	9,150	9,250	9,250	9,250
	3.05	9,100	9,600*	9,250*	9,250	9,700*	9,400*

Dimensions are with equipment over steering axle

* Equipment over digging axle for shorter transport dimensions

W = Max. ground clearance including approx. 150mm piping

Lift capacities

with two-piece boom 5.40 m

Stick 2.25 m

m	Undercarriage stabilized		3.0m		4.5m		6.0m		7.5m		m
	rear	front	rear	front	rear	front	rear	front	rear	front	
9.0	-	-									
	Blade	-									
	Outriggers	Blade									
7.5	-	-			5.1	5.5*			3.3	3.4*	
	Blade	-			5.5*	5.5*			3.4*	3.4*	
	Outriggers	Blade			5.5*	5.5*			3.4*	3.4*	5.7
6.0	-	-			5.8*	5.8*	3.2	5.2	2.3	3.1*	
	Blade	-			5.6	5.8*	3.5	5.4*	2.5	3.1*	
	Outriggers	Blade			5.8*	5.8*	5.2	5.4*	3.1*	3.1*	7.0
4.5	-	-	8.3*	8.3*	4.9	7.6*	3.2	5.2	2.0	3.4	
	Blade	-	8.3*	8.3*	5.4	7.6*	3.5	6.3*	2.2	4.0*	
	Outriggers	Blade	8.3*	8.3*	7.6*	7.6*	5.2	6.2*	3.5	4.0*	7.7
3.0	-	-	8.3*	8.3*	7.6*	7.6*	6.1	6.2*	4.0*	4.0*	
	Blade	-	8.5	13.1*	4.7	7.8	3.2	5.1	2.0	3.4	
	Outriggers	Blade	13.1*	13.1*	7.8	9.0*	5.2	6.8*	3.5	5.7*	8.1
1.5	-	-	8.3	13.0*	4.6	7.7	3.1	5.1	1.9	3.3	
	Blade	-	9.3	13.0*	5.1	10.1*	3.4	7.3*	2.1	5.8	
	Outriggers	Blade	13.0*	13.0*	7.7	10.1*	5.1	7.3*	3.4	5.8*	8.2
0	-	-	8.0	15.0*	4.5	7.7	2.8	4.9	1.8	3.2	
	Blade	-	9.0	15.0*	4.9	10.3*	3.1	7.5*	2.0	5.7	
	Outriggers	Blade	14.8	14.9*	7.7	10.3*	5.0	7.4*	3.3	5.8*	8.0
-1.5	-	-	7.6	15.4	4.2	7.6	2.6	4.6	1.7	3.1	
	Blade	-	8.5	16.8*	4.7	10.5*	2.9	7.6*	1.9	4.4*	
	Outriggers	Blade	15.2	16.8*	7.6	10.4*	4.6	7.6*	3.2	4.4*	7.5
-3.0	-	-	7.5	15.4	3.9	7.2	2.4	4.4	2.1	3.8	
	Blade	-	8.4	17.4*	4.3	10.6*	2.7	6.3*	2.3	4.5*	
	Outriggers	Blade	15.0	17.3*	7.2	10.6*	4.4	6.2*	3.9	4.4*	6.5
-4.5	-	-	7.2	11.8*					4.4*	4.4*	
	Blade	-	8.1	11.8*					4.7	7.5*	
	Outriggers	Blade	11.7*	11.7*					7.4*	7.4*	3.9

Stick 2.45 m

m	Undercarriage stabilized		3.0m		4.5m		6.0m		7.5m		m
	rear	front	rear	front	rear	front	rear	front	rear	front	
9.0	-	-									4.1*
	Blade	-									4.1*
	Outriggers	Blade									4.1*
7.5	-	-									3.0
	Blade	-			5.1*	5.1*			3.0	3.1*	
	Outriggers	Blade			5.1*	5.1*	3.1*	3.1*	3.1*	3.1*	6.0
6.0	-	-									2.2
	Blade	-			5.3*	5.3*	3.5	5.1*	2.4	2.8*	
	Outriggers	Blade			5.3*	5.3*	5.1*	5.1*	2.8*	2.8*	7.2
4.5	-	-	6.5*	6.5*	4.9	6.6*	3.2	5.2	2.0	3.5	
	Blade	-	6.5*	6.5*	5.4	6.6*	3.5	6.1*	2.2	4.3*	
	Outriggers	Blade	6.5*	6.5*	6.6*	6.6*	5.2	6.1*	3.5	4.3*	7.9
3.0	-	-	8.5	13.3*	4.7	7.8	3.1	5.1	2.0	3.4	
	Blade	-	9.5	13.3*	5.2	8.8*	3.4	6.7*	2.2	5.6*	
	Outriggers	Blade	13.3*	13.3*	7.8	8.8*	5.1	6.7*	3.5	5.6*	8.3
1.5	-	-	8.3	12.8*	4.6	7.6	3.1	5.0	1.9	3.4	
	Blade	-	9.2	12.8*	5.1	10.0*	3.4	7.2*	2.1	5.7*	
	Outriggers	Blade	12.8*	12.8*	7.6	10.0*	5.1	7.2*	3.4	5.7*	8.4
0	-	-	8.1	14.6*	4.5	7.6	2.9	4.9	1.8	3.2	
	Blade	-	9.1	14.6*	4.9	10.3*	3.2	7.4*	2.0	5.7	
	Outriggers	Blade	14.6*	14.6*	7.7	10.2*	5.0	7.4*	3.3	5.8*	8.2
-1.5	-	-	7.6	15.3	4.2	7.6	2.6	4.6	1.6	3.1	
	Blade	-	8.5	16.6*	4.7	10.4*	2.9	7.5*	1.9	5.1*	
	Outriggers	Blade	15.1	16.6*	7.6	10.3*	4.7	7.5*	3.1	5.1*	7.7
-3.0	-	-	7.4	15.3	3.9	7.2	2.4	4.4	1.9	3.6	
	Blade	-	8.4	17.2*	4.4	10.7*	2.7	6.7*	2.2	4.4*	
	Outriggers	Blade	15.0	17.1*	7.2	10.7*	4.4	6.7*	3.6	4.3*	6.8
-4.5	-	-	7.1	13.3*	3.7	6.4*			4.3*	4.3*	
	Blade	-	8.1	13.3*	4.2	6.4*			3.6	6.0*	
	Outriggers	Blade	13.2*	13.2*	6.4*	6.4*			6.0*	6.0*	4.6

Height Can be slewed through 360° In longitudinal position of undercarriage Max. reach * Limited by hydr. capacity

The lift capacities on the load hook of the Liebherr quick coupler SWA 48 without attachment are stated in metric tons (t) and are valid on a firm, level supporting surface with blocked oscillating axle. These capacities can be slewed through 360° with the undercarriage in the transverse position. Capacities in the longitudinal position of the undercarriage ($\pm 15^\circ$) are specified over the steering axle with the stabilizers raised and over the rigid axle with the stabilizers down. The values apply when the adjusting cylinder is in the optimal position. Indicated loads based on the ISO 10567 standard and do not exceed 75% of tipping or 87% of hydraulic capacity, or are limited by the permissible load of the load hook on the quick coupler (max. 12t). Without the quick coupler, lift capacities will increase by up to 226 kg.

In accordance with the harmonised European Standard EN 474-5, hydraulic excavators used for lifting operations must be equipped with pipe fracture safety valves, an overload warning device, a load hook and a lift capacity chart.

Lift capacities

with two-piece boom 5.40 m

Stick 2.65 m

m	Undercarriage stabilized		3.0m		4.5m		6.0m		7.5m		m
	rear	front	rear	front	rear	front	rear	front	rear	front	
9.0	-	-							3.7*	3.7*	4.3
	Blade	-							3.7*	3.7*	
	Outriggers	Blade							3.6*	3.6*	
7.5	-	-					3.1	3.7*	2.8	2.9*	6.3
	Blade	-					3.4	3.7*	2.9*	2.9*	
	Outriggers	Blade			3.7*	3.7*			2.9*	2.9*	
6.0	-	-					3.2	4.8*	2.0	2.6*	7.4
	Blade	-					3.5	4.8*	2.2	2.6*	
	Outriggers	Blade			4.8*	4.8*			2.6*	2.6*	
4.5	-	-			4.9	5.8*	3.2	5.2	2.0	3.5	8.1
	Blade	-			5.4	5.8*	3.5	5.7*	2.3	4.4*	
	Outriggers	Blade			5.8*	5.8*	5.2	5.7*	3.5	4.4*	
3.0	-	-	8.6	13.4*	4.7	7.8	3.1	5.1	2.0	3.5	8.5
	Blade	-	9.5	13.4*	5.2	8.5*	3.4	6.6*	2.2	5.5*	
	Outriggers	Blade	13.4*	13.4*	7.8	8.5*	5.1	6.5*	3.5	5.5*	
1.5	-	-	8.2	12.8*	4.6	7.6	3.1	5.0	1.9	3.4	8.6
	Blade	-	9.2	12.8*	5.0	9.8*	3.4	7.1*	2.1	5.7*	
	Outriggers	Blade	12.8*	12.8*	7.6	9.8*	5.1	7.1*	3.4	5.7*	
0	-	-	8.1	14.3*	4.5	7.6	2.9	5.0	1.8	3.2	8.4
	Blade	-	9.1	14.3*	5.0	10.2*	3.2	7.4*	2.0	5.7	
	Outriggers	Blade	14.3*	14.3*	7.6	10.2*	5.0	7.3*	3.3	5.7*	
-1.5	-	-	7.6	15.2	4.2	7.6	2.6	4.7	1.6	3.1	7.9
	Blade	-	8.5	16.4*	4.6	10.3*	2.9	7.5*	1.9	5.4*	
	Outriggers	Blade	14.9	16.3*	7.6	10.3*	4.7	7.4*	3.1	5.3*	
-3.0	-	-	7.4	15.2	3.9	7.3	2.4	4.4			7.0
	Blade	-	8.3	17.0*	4.4	10.7*	2.7	7.0*	2.0	4.3*	
	Outriggers	Blade	14.9	17.0*	7.3	10.7*	4.4	7.0*	3.4	4.3*	
-4.5	-	-	7.1	14.6*	3.7	7.0					5.1
	Blade	-	8.1	14.6*	4.1	7.5*			3.0	5.2*	
	Outriggers	Blade	14.5*	14.5*	7.0	7.5*			5.2*	5.2*	

Stick 3.05 m

m	Undercarriage stabilized		3.0m		4.5m		6.0m		7.5m		m
	rear	front	rear	front	rear	front	rear	front	rear	front	
9.0	-	-			3.1*	3.1*					4.6
	Blade	-			3.1*	3.1*					
	Outriggers	Blade			3.1*	3.1*					
7.5	-	-					3.2	3.2*			6.5
	Blade	-					3.2*	3.2*			
	Outriggers	Blade					3.2*	3.2*			
6.0	-	-					3.3	4.1*	2.0	2.5*	7.6
	Blade	-					3.6	4.1*	2.3	2.5*	
	Outriggers	Blade			4.1*	4.1*	2.5*	2.5*	2.2*	2.2*	
4.5	-	-			4.9	5.2*	3.2	5.0*	2.1	3.5	8.3
	Blade	-			5.2*	5.2*	3.5	5.0*	2.3	3.9*	
	Outriggers	Blade			5.2*	5.2*	5.0*	5.0*	3.6	3.9*	
3.0	-	-	8.6	12.4*	4.7	7.8	3.1	5.0	2.0	3.5	8.7
	Blade	-	9.6	12.4*	5.2	8.0*	3.4	6.3*	2.3	4.9*	
	Outriggers	Blade	12.4*	12.4*	7.8	8.0*	5.1	6.3*	3.5	4.9*	
1.5	-	-	8.2	13.3*	4.5	7.5	3.0	5.0	1.9	3.4	8.7
	Blade	-	9.1	13.3*	5.0	9.5*	3.3	6.9*	2.2	5.6*	
	Outriggers	Blade	13.3*	13.3*	7.6	9.5*	5.0	6.9*	3.4	5.5*	
0	-	-	8.1	14.2*	4.5	7.5	2.9	5.0	1.8	3.2	8.5
	Blade	-	9.1	14.2*	5.0	10.1*	3.2	7.3*	2.0	5.7	
	Outriggers	Blade	14.1*	14.1*	7.5	10.1*	5.0	7.3*	3.3	5.6*	
-1.5	-	-	7.6	14.9	4.2	7.6	2.6	4.7	1.6	3.1	8.1
	Blade	-	8.6	16.0*	4.6	10.2*	2.9	7.3*	1.8	5.5*	
	Outriggers	Blade	14.7	15.9*	7.6	10.2*	4.7	7.3*	3.1	5.5*	
-3.0	-	-	7.3	15.2	3.9	7.3	2.3	4.4			7.2
	Blade	-	8.3	16.8*	4.4	10.5*	2.6	7.3*			
	Outriggers	Blade	14.9	16.7*	7.3	10.4*	4.4	7.3*			
-4.5	-	-	7.0	14.7	3.6	6.9					5.8
	Blade	-	7.9	15.8*	4.0	8.7*					
	Outriggers	Blade	14.4	15.7*	6.8	8.6*					

Height Can be slewed through 360° In longitudinal position of undercarriage Max. reach * Limited by hydr. capacity

The lift capacities on the load hook of the Liebherr quick coupler SWA 48 without attachment are stated in metric tons (t) and are valid on a firm, level supporting surface with blocked oscillating axle. These capacities can be slewed through 360° with the undercarriage in the transverse position. Capacities in the longitudinal position of the undercarriage (±15°) are specified over the steering axle with the stabilizers raised and over the rigid axle with the stabilizers down. The values apply when the adjusting cylinder is in the optimal position. Indicated loads based on the ISO 10567 standard and do not exceed 75% of tipping or 87% of hydraulic capacity, or are limited by the permissible load of the load hook on the quick coupler (max. 12t). Without the quick coupler, lift capacities will increase by up to 226 kg.

In accordance with the harmonised European Standard EN 474-5, hydraulic excavators used for lifting operations must be equipped with pipe fracture safety valves, an overload warning device, a load hook and a lift capacity chart.

Lift capacities

with two-piece boom 5.40 m, EW undercarriage

Stick 2.25 m

m	Undercarriage stabilized		3.0 m		4.5 m		6.0 m		7.5 m		m
	rear	front									
9.0	-	-									
	Blade	-									
	Outriggers	Blade									
7.5	-	-			5.5*	5.5*			3.4*	3.4*	5.7
	Blade	-			5.5*	5.5*			3.4*	3.4*	
	Outriggers	Blade			5.5*	5.5*			3.4*	3.4*	
6.0	-	-			5.6	5.8*	3.5	5.2	2.5	3.1*	7.0
	Blade	-			5.8*	5.8*	3.8	5.4*	2.8	3.1*	
	Outriggers	Blade			5.8*	5.8*	5.4*	5.4*	3.1*	3.1*	
4.5	-	-	8.3*	8.3*	5.4	7.6*	3.5	5.2	2.2	3.5	7.7
	Blade	-	8.3*	8.3*	5.9	7.6*	3.9	6.3*	2.4	4.0*	
	Outriggers	Blade	8.3*	8.3*	7.6*	7.6*	5.5	6.2*	3.7	4.0*	
3.0	-	-	9.5	13.1*	5.2	7.8	3.5	5.1	2.2	3.5	8.1
	Blade	-	10.5	13.1*	5.7	9.0*	3.8	6.8*	2.4	5.7*	
	Outriggers	Blade	13.1*	13.1*	8.1	9.0*	5.4	6.8*	3.6	5.7*	
1.5	-	-	9.3	13.0*	5.1	7.7	3.4	5.1	2.1	3.4	8.2
	Blade	-	10.3	13.0*	5.6	10.1*	3.7	7.3*	2.3	5.8*	
	Outriggers	Blade	13.0*	13.0*	8.0	10.1*	5.4	7.3*	3.6	5.8*	
0	-	-	9.1	15.0*	5.0	7.8	3.2	4.9	2.0	3.2	8.0
	Blade	-	10.2	15.0*	5.5	10.3*	3.5	7.5*	2.2	5.8*	
	Outriggers	Blade	14.9*	14.9*	8.1	10.3*	5.2	7.4*	3.4	5.8*	
-1.5	-	-	8.6	15.5	4.7	7.6	2.9	4.7	1.9	3.2	7.5
	Blade	-	9.7	16.8*	5.2	10.5*	3.2	7.6*	2.1	4.4*	
	Outriggers	Blade	15.9	16.8*	8.0	10.4*	4.9	7.6*	3.4	4.4*	
-3.0	-	-	8.5	15.5	4.4	7.2	2.7	4.5	2.3	3.9	6.5
	Blade	-	9.6	17.4*	4.9	10.6*	3.0	6.3*	2.6	4.5*	
	Outriggers	Blade	16.1	17.3*	7.6	10.6*	4.7	6.2*	4.1	4.4*	
-4.5	-	-	8.2	11.8*					5.3	7.5*	3.9
	Blade	-	9.3	11.8*					5.9	7.5*	
	Outriggers	Blade	11.7*	11.7*					7.4*	7.4*	

Stick 2.45 m

m	Undercarriage stabilized		3.0 m		4.5 m		6.0 m		7.5 m		m
	rear	front									
9.0	-	-									3.9
	Blade	-									
	Outriggers	Blade									
7.5	-	-			5.1*	5.1*			3.1*	3.1*	6.0
	Blade	-			5.1*	5.1*			3.1*	3.1*	
	Outriggers	Blade			5.1*	5.1*	3.1*	3.1*	3.1*	3.1*	
6.0	-	-			5.3*	5.3*	3.5	5.1*	2.4	2.8*	7.2
	Blade	-			5.3*	5.3*	3.9	5.1*	2.7	2.8*	
	Outriggers	Blade			5.3*	5.3*	5.1*	5.1*	2.8*	2.8*	
4.5	-	-	6.5*	6.5*	5.4	6.6*	3.5	5.2	2.2	3.5	7.9
	Blade	-	6.5*	6.5*	5.9	6.6*	3.9	6.1*	2.5	4.3*	
	Outriggers	Blade	6.5*	6.5*	6.6*	6.6*	5.4	6.1*	3.7	4.3*	
3.0	-	-	9.5	13.3*	5.2	7.8	3.5	5.1	2.2	3.5	8.3
	Blade	-	10.5	13.3*	5.7	8.8*	3.8	6.7*	2.4	5.6*	
	Outriggers	Blade	13.3*	13.3*	8.1	8.8*	5.3	6.7*	3.7	5.6*	
1.5	-	-	9.3	12.8*	5.1	7.7	3.4	5.1	2.1	3.4	8.4
	Blade	-	10.2	12.8*	5.6	10.0*	3.8	7.2*	2.4	5.7*	
	Outriggers	Blade	12.8*	12.8*	8.0	10.0*	5.3	7.2*	3.6	5.7*	
0	-	-	9.1	14.6*	5.0	7.7	3.2	5.0	2.0	3.3	8.2
	Blade	-	10.3	14.6*	5.5	10.3*	3.5	7.4*	2.2	5.8*	
	Outriggers	Blade	14.6*	14.6*	8.0	10.2*	5.2	7.4*	3.4	5.8*	
-1.5	-	-	8.6	15.4	4.7	7.6	2.9	4.7	1.9	3.1	7.7
	Blade	-	9.7	16.6*	5.2	10.4*	3.2	7.5*	2.1	5.1*	
	Outriggers	Blade	15.8	16.6*	8.0	10.3*	4.9	7.5*	3.3	5.1*	
-3.0	-	-	8.4	15.4	4.4	7.3	2.7	4.5	2.2	3.6	6.8
	Blade	-	9.5	17.2*	4.9	10.7*	3.0	6.7*	2.4	4.4*	
	Outriggers	Blade	16.0	17.1*	7.6	10.7*	4.7	6.7*	3.8	4.3*	
-4.5	-	-	8.1	13.3*	4.2	6.4*			4.0	6.0*	4.6
	Blade	-	9.2	13.3*	4.7	6.4*			4.5	6.0*	
	Outriggers	Blade	13.2*	13.2*	6.4*	6.4*			6.0*	6.0*	

Height Can be slewed through 360° In longitudinal position of undercarriage Max. reach * Limited by hydr. capacity

The lift capacities on the load hook of the Liebherr quick coupler SWA 48 without attachment are stated in metric tons (t) and are valid on a firm, level supporting surface with blocked oscillating axle. These capacities can be slewed through 360° with the undercarriage in the transverse position. Capacities in the longitudinal position of the undercarriage ($\pm 15^\circ$) are specified over the steering axle with the stabilizers raised and over the rigid axle with the stabilizers down. The values apply when the adjusting cylinder is in the optimal position. Indicated loads based on the ISO 10567 standard and do not exceed 75% of tipping or 87% of hydraulic capacity, or are limited by the permissible load of the load hook on the quick coupler (max. 12 t). Without the quick coupler, lift capacities will increase by up to 226 kg.

In accordance with the harmonised European Standard EN 474-5, hydraulic excavators used for lifting operations must be equipped with pipe fracture safety valves, an overload warning device, a load hook and a lift capacity chart.

Lift capacities

with two-piece boom 5.40 m, EW undercarriage

Stick 2.65 m

m	Undercarriage stabilized		3.0m		4.5m		6.0m		7.5m		m
	rear	front									
9.0	-	-							3.7*	3.7*	4.3
	Blade	-							3.7*	3.7*	
	Outriggers	Blade							3.6*	3.6*	
7.5	-	-					3.4	3.7*	2.9*	2.9*	6.3
	Blade	-					3.7*	3.7*	2.9*	2.9*	
	Outriggers	Blade					3.7*	3.7*	2.9*	2.9*	
6.0	-	-					3.6	4.8*	2.3	2.6*	7.4
	Blade	-					3.9	4.8*	2.5	2.6*	
	Outriggers	Blade					4.8*	4.8*	2.6*	2.6*	
4.5	-	-			5.4	5.8*	3.5	5.2	2.3	3.5	8.1
	Blade	-			5.8	5.8*	3.8	5.7*	2.5	4.4*	
	Outriggers	Blade			5.8*	5.8*	5.4	5.7*	3.7	4.4*	
3.0	-	-	9.5	13.4*	5.2	7.8	3.4	5.1	2.2	3.5	8.5
	Blade	-	10.5	13.4*	5.7	8.5*	3.8	6.6*	2.5	5.5*	
	Outriggers	Blade	13.4*	13.4*	8.1	8.5*	5.3	6.5*	3.7	5.5*	
1.5	-	-	9.2	12.8*	5.1	7.6	3.4	5.0	2.1	3.4	8.6
	Blade	-	10.2	12.8*	5.6	9.8*	3.8	7.1*	2.4	5.7*	
	Outriggers	Blade	12.8*	12.8*	7.9	9.8*	5.3	7.1*	3.6	5.7*	
0	-	-	9.2	14.3*	5.0	7.6	3.2	5.0	2.0	3.3	8.4
	Blade	-	10.2*	14.3*	5.5	10.2*	3.6	7.4*	2.2	5.7*	
	Outriggers	Blade	14.3*	14.3*	8.0	10.2*	5.3	7.3*	3.5	5.7*	
-1.5	-	-	8.6	15.2	4.7	7.6	2.9	4.7	1.9	3.1	7.9
	Blade	-	9.7	16.4*	5.2	10.3*	3.3	7.5*	2.1	5.4*	
	Outriggers	Blade	15.7	16.3*	8.0	10.3*	5.0	7.4*	3.3	5.3*	
-3.0	-	-	8.4	15.4	4.4	7.3	2.7	4.5			7.0
	Blade	-	9.5	17.0*	4.9	10.7*	3.0	7.0*			
	Outriggers	Blade	16.0	17.0*	7.7	10.7*	4.7	7.0*			
-4.5	-	-	8.1	14.6*	4.2	7.0			3.4	5.2*	5.1
	Blade	-	9.2	14.6*	4.7	7.5*			3.8	5.2*	
	Outriggers	Blade	14.5*	14.5*	7.4	7.5*			5.2*	5.2*	

Stick 3.05 m

m	Undercarriage stabilized		3.0m		4.5m		6.0m		7.5m		m
	rear	front									
9.0	-	-									4.6
	Blade	-			3.1*	3.1*					
	Outriggers	Blade			3.1*	3.1*					
7.5	-	-					3.2*	3.2*			6.5
	Blade	-					3.2*	3.2*			
	Outriggers	Blade					3.2*	3.2*			
6.0	-	-					3.6	4.1*	2.3	2.5*	7.6
	Blade	-					3.9	4.1*	2.5*	2.5*	
	Outriggers	Blade					4.1*	4.1*	2.5*	2.5*	
4.5	-	-					5.2*	5.2*	3.5	5.0*	8.3
	Blade	-					5.2*	5.2*	3.8	5.0*	
	Outriggers	Blade					5.2*	5.2*	5.0*	5.0*	
3.0	-	-	9.6	12.4*	5.2	7.8	3.4	5.1	2.3	3.5	8.7
	Blade	-	10.6	12.4*	5.7	8.0*	3.7	6.3*	2.5	4.9*	
	Outriggers	Blade	12.4*	12.4*	8.0*	8.0*	5.3	6.3*	3.7	4.9*	
1.5	-	-	9.2	13.3*	5.0	7.6	3.4	5.0	2.2	3.4	8.7
	Blade	-	10.1	13.3*	5.5	9.5*	3.7	6.9*	2.4	5.6*	
	Outriggers	Blade	13.3*	13.3*	7.9	9.5*	5.2	6.9*	3.6	5.5*	
0	-	-	9.1	14.2*	5.0	7.6	3.2	5.0	2.0	3.3	8.5
	Blade	-	10.1	14.2*	5.5	10.1*	3.6	7.3*	2.2	5.7*	
	Outriggers	Blade	14.1*	14.1*	7.9	10.1*	5.2	7.3*	3.5	5.6*	
-1.5	-	-	8.6	15.0	4.7	7.6	2.9	4.7	1.8	3.1	8.1
	Blade	-	9.7	16.0*	5.2	10.2*	3.3	7.3*	2.1	5.5*	
	Outriggers	Blade	15.5	15.9*	8.0	10.2*	5.0	7.3*	3.3	5.5*	
-3.0	-	-	8.3	15.3	4.4	7.3	2.6	4.4			7.2
	Blade	-	9.4	16.8*	4.9	10.5*	3.0	7.3*			
	Outriggers	Blade	15.9	16.7*	7.7	10.4*	4.6	7.3*			
-4.5	-	-	8.0	14.8	4.1	6.9					5.8
	Blade	-	9.1	15.8*	4.6	8.7*					
	Outriggers	Blade	15.4	15.7*	7.2	8.6*					

Height Can be slewed through 360° In longitudinal position of undercarriage Max. reach * Limited by hydr. capacity

The lift capacities on the load hook of the Liebherr quick coupler SWA 48 without attachment are stated in metric tons (t) and are valid on a firm, level supporting surface with blocked oscillating axle. These capacities can be slewed through 360° with the undercarriage in the transverse position. Capacities in the longitudinal position of the undercarriage ($\pm 15^\circ$) are specified over the steering axle with the stabilizers raised and over the rigid axle with the stabilizers down. The values apply when the adjusting cylinder is in the optimal position. Indicated loads based on the ISO 10567 standard and do not exceed 75% of tipping or 87% of hydraulic capacity, or are limited by the permissible load of the load hook on the quick coupler (max. 12 t). Without the quick coupler, lift capacities will increase by up to 226 kg.

In accordance with the harmonised European Standard EN 474-5, hydraulic excavators used for lifting operations must be equipped with pipe fracture safety valves, an overload warning device, a load hook and a lift capacity chart.

Lift capacities

with two-piece boom 5.40 m (heavy counterweight)

Stick 2.25 m

m	Undercarriage stabilized		3.0m		4.5m		6.0m		7.5m		m	
	rear	front										
9.0	Blade	-										
	Outriggers	Blade										
7.5	Blade	-			5.5	5.5*				3.4*	3.4*	
	Outriggers	Blade			5.5*	5.5*				3.4*	3.4*	
6.0	Blade	-			5.4	5.8*	3.4	5.4*		2.5	3.1*	
	Outriggers	Blade			5.8*	5.8*	5.4*	5.4*		3.1*	3.1*	
4.5	Blade	-	8.4*	8.4*	5.2	7.6*	3.5	5.5	2.2	3.7	2.0	3.0*
	Outriggers	Blade	8.4*	8.4*	5.7	7.6*	3.8	6.3*	2.4	4.0*	2.2	3.0*
3.0	Blade	-	9.1	13.1*	5.1	8.2	3.4	5.4	2.1	3.7	1.8	3.1*
	Outriggers	Blade	13.0*	13.0*	8.2	9.0*	5.4	6.8*	3.7	5.7*	3.1*	3.1*
1.5	Blade	-	8.9	13.0*	5.0	8.0	3.3	5.4	2.1	3.6	1.7	3.0
	Outriggers	Blade	13.0*	13.0*	8.1	10.1*	5.4	7.3*	3.6	5.8*	3.1	3.3*
0	Blade	-	8.6	15.0*	4.8	8.1	3.1	5.2	1.9	3.5	1.7	3.1
	Outriggers	Blade	15.0*	15.0*	8.1	10.3*	5.2	7.4*	3.5	5.8*	3.1	3.6*
-1.5	Blade	-	8.2	16.1	4.6	8.0	2.8	4.9			1.9	3.4
	Outriggers	Blade	15.8	16.8*	8.0	10.4*	4.9	7.6*			3.4	4.4*
-3.0	Blade	-	8.1	16.3	4.2	7.6	2.6	4.7			2.3	4.1
	Outriggers	Blade	15.9	17.3*	7.6	10.5*	4.8	6.2*			2.6	4.4*
-4.5	Blade	-	7.8	11.7*							5.2	7.6*
	Outriggers	Blade	11.6*	11.6*							7.6*	7.6*

Stick 2.45 m

m	Undercarriage stabilized		3.0m		4.5m		6.0m		7.5m		m	
	rear	front										
9.0	Blade	-									4.1*	4.1*
	Outriggers	Blade									4.1*	4.1*
7.5	Blade	-					5.1*	5.1*	3.2*	3.2*	3.1*	3.1*
	Outriggers	Blade					5.1*	5.1*	3.2*	3.2*	3.1*	3.1*
6.0	Blade	-					5.3*	5.3*	3.5	5.1*	2.3	2.8*
	Outriggers	Blade					5.3*	5.3*	5.1*	5.1*	2.6	2.8*
4.5	Blade	-	6.6*	6.6*	5.2	6.6*	3.4	5.4	2.2	3.7	1.9	2.7*
	Outriggers	Blade	6.6*	6.6*	5.7	6.6*	3.8	6.1*	2.4	4.3*	2.1	2.7*
3.0	Blade	-	9.1	13.3*	5.0	8.1	3.4	5.3	2.2	3.7	1.7	2.8*
	Outriggers	Blade	13.3*	13.3*	8.2	8.8*	5.4	6.7*	3.7	5.6*	2.8*	2.8*
1.5	Blade	-	8.9	12.9*	4.9	8.0	3.3	5.3	2.1	3.6	1.6	2.9
	Outriggers	Blade	12.9*	12.9*	8.0	10.0*	5.4	7.2*	3.6	5.7*	2.9	2.9*
0	Blade	-	8.7	14.6*	4.8	8.0	3.1	5.2	1.9	3.5	1.6	2.9
	Outriggers	Blade	14.6*	14.6*	8.0	10.2*	5.3	7.4*	3.5	5.8*	3.0	3.3*
-1.5	Blade	-	8.2	15.9	4.5	8.0	2.8	4.9	1.8	3.3	1.8	3.2
	Outriggers	Blade	15.7	16.6*	8.0	10.4*	5.0	7.5*	2.1	5.1*	2.0	3.9*
-3.0	Blade	-	8.0	16.2	4.2	7.7	2.6	4.7			2.1	3.9
	Outriggers	Blade	15.9	17.2*	7.7	10.7*	4.7	6.7*			2.4	4.4*
-4.5	Blade	-	7.7	13.2*	4.1	6.4*					4.0	6.1*
	Outriggers	Blade	13.1*	13.1*	6.3*	6.3*					4.4	6.1*

Height Can be slewed through 360° In longitudinal position of undercarriage Max. reach * Limited by hydr. capacity

The lift capacities on the load hook of the Liebherr quick coupler SWA 48 without attachment are stated in metric tons (t) and are valid on a firm, level supporting surface with blocked oscillating axle. These capacities can be slewed through 360° with the undercarriage in the transverse position. Capacities in the longitudinal position of the undercarriage (±15°) are specified over the steering axle with the stabilizers raised and over the rigid axle with the stabilizers down. The values apply when the adjusting cylinder is in the optimal position. Indicated loads based on the ISO 10567 standard and do not exceed 75% of tipping or 87% of hydraulic capacity, or are limited by the permissible load of the load hook on the quick coupler (max. 12 t). Without the quick coupler, lift capacities will increase by up to 226 kg.

In accordance with the harmonised European Standard EN 474-5, hydraulic excavators used for lifting operations must be equipped with pipe fracture safety valves, an overload warning device, a load hook and a lift capacity chart.

Stick 2.65 m

m	Undercarriage stabilized		3.0m		4.5m		6.0m		7.5m		m
	rear	front									
9.0	-	-							3.6*	3.6*	4.3
	Blade	-							3.6*	3.6*	
7.5	Outriggers	Blade							2.9*	2.9*	6.3
	-	-							2.9*	2.9*	
6.0	Blade	-							2.2	2.6*	7.4
	Outriggers	Blade							2.4	2.6*	
4.5	-	-							1.8	2.5*	8.1
	Blade	-							2.0	2.5*	
3.0	Outriggers	Blade							2.5*	2.5*	8.5
	-	-	9.2	13.5*	5.0	8.1	3.4	5.3	2.2	3.7	
1.5	Blade	-	10.0	13.5*	5.5	8.6*	3.7	6.6*	2.4	5.5*	8.6
	Outriggers	Blade	13.4*	13.4*	8.2	8.6*	5.4	6.5*	3.7	5.5*	
0	-	-	8.8	12.8*	4.9	8.0	3.3	5.3	2.1	3.6	8.4
	Blade	-	9.7	12.8*	5.4	9.8*	3.7	7.1*	2.3	5.7*	
-1.5	Outriggers	Blade	12.8*	12.8*	8.0	9.8*	5.3	7.1*	3.7	5.7*	7.9
	-	-	8.7	14.3*	4.8	8.0	3.2	5.3	2.0	3.5	
-3.0	Blade	-	9.7	14.3*	5.3	10.2*	3.5	7.4*	2.2	5.7*	7.0
	Outriggers	Blade	14.3*	14.3*	8.0	10.2*	5.3	7.3*	3.5	5.7*	
-4.5	-	-	8.2	15.8	4.5	8.0	2.9	5.0	1.8	3.3	5.1
	Blade	-	9.2	16.4*	5.0	10.3*	3.2	7.5*	2.1	5.4*	
-3.0	Outriggers	Blade	15.6	16.4*	8.0	10.3*	5.0	7.4*	3.4	5.3*	7.0
	-	-	8.0	16.2	4.3	7.7	2.6	4.7			
-4.5	Blade	-	9.0	17.0*	4.8	10.7*	2.9	7.0*	2.2	4.3*	5.1
	Outriggers	Blade	15.8	17.0*	7.7	10.7*	4.7	7.0*	3.7	4.3*	
-4.5	-	-	7.7	14.5*	4.0	7.4			3.3	5.3*	5.8
	Blade	-	8.7	14.5*	4.5	7.5*			3.7	5.3*	
-4.5	Outriggers	Blade	14.4*	14.4*	7.4	7.4*			5.2*	5.2*	5.1
	-	-									

Stick 3.05 m

m	Undercarriage stabilized		3.0m		4.5m		6.0m		7.5m		m
	rear	front									
9.0	-	-									4.7
	Blade	-									
7.5	Outriggers	Blade									6.5
	-	-									
6.0	Blade	-									7.6
	Outriggers	Blade									
4.5	-	-									8.3
	Blade	-									
3.0	Outriggers	Blade									8.7
	-	-	9.2	12.4*	5.0	8.1*	3.3	5.3	2.2	3.7	
1.5	Blade	-	10.1	12.4*	5.5	8.1*	3.6	6.3*	2.5	5.0*	8.7
	Outriggers	Blade	12.4*	12.4*	8.1*	8.1*	5.3	6.3*	3.7	5.0*	
0	-	-	8.8	13.3*	4.9	7.9	3.3	5.2	2.1	3.6	8.7
	Blade	-	9.7	13.3*	5.4	9.5*	3.6	6.9*	2.4	5.6*	
-1.5	Outriggers	Blade	13.3*	13.3*	7.9	9.5*	5.3	6.9*	3.7	5.5*	8.5
	-	-	8.7	14.2*	4.8	7.9	3.2	5.2	2.0	3.5	
-3.0	Blade	-	9.6	14.2*	5.3	10.1*	3.5	7.3*	2.2	5.7*	8.1
	Outriggers	Blade	14.2*	14.2*	7.9	10.1*	5.3	7.3*	3.5	5.6*	
-4.5	-	-	8.2	15.6	4.5	8.0	2.9	5.0	1.8	3.3	7.2
	Blade	-	9.2	16.0*	5.0	10.2*	3.2	7.3*	2.0	5.5*	
-3.0	Outriggers	Blade	15.4	15.9*	8.0	10.2*	5.0	7.3*	3.3	5.5*	7.2
	-	-	7.9	16.1	4.3	7.7	2.6	4.7			
-4.5	Blade	-	8.9	16.8*	4.7	10.5*	2.9	7.3*	2.1	4.4*	5.8
	Outriggers	Blade	15.8	16.7*	7.7	10.4*	4.7	7.3*	3.4	4.4*	
-4.5	-	-	7.6	15.7	3.9	7.3			2.6	4.4*	5.8
	Blade	-	8.5	15.7*	4.4	8.6*			3.0	4.4*	
-4.5	Outriggers	Blade	15.3	15.6*	7.3	8.6*			4.4*	4.4*	5.1
	-	-									

Height Can be slewed through 360° In longitudinal position of undercarriage Max. reach * Limited by hydr. capacity

The lift capacities on the load hook of the Liebherr quick coupler SWA 48 without attachment are stated in metric tons (t) and are valid on a firm, level supporting surface with blocked oscillating axle. These capacities can be slewed through 360° with the undercarriage in the transverse position. Capacities in the longitudinal position of the undercarriage ($\pm 15^\circ$) are specified over the steering axle with the stabilizers raised and over the rigid axle with the stabilizers down. The values apply when the adjusting cylinder is in the optimal position. Indicated loads based on the ISO 10567 standard and do not exceed 75% of tipping or 87% of hydraulic capacity, or are limited by the permissible load of the load hook on the quick coupler (max. 12 t). Without the quick coupler, lift capacities will increase by up to 226 kg.

In accordance with the harmonised European Standard EN 474-5, hydraulic excavators used for lifting operations must be equipped with pipe fracture safety valves, an overload warning device, a load hook and a lift capacity chart.

Lift capacities

with two-piece boom 5.40 m (heavy counterweight), EW undercarriage

Stick 2.25 m

m	Undercarriage stabilized		3.0m		4.5m		6.0m		7.5m		m	
	rear	front										
9.0	Blade	-										
	Outriggers	Blade										
7.5	Blade	-			5.5*	5.5*				3.4*	3.4*	
	Outriggers	Blade			5.5*	5.5*				3.4*	3.4*	
6.0	Blade	-			5.8*	5.8*	3.7	5.4*		2.8	3.1*	
	Outriggers	Blade			5.8*	5.8*	5.4*	5.4*		3.1*	3.1*	
4.5	Blade	-	8.4*	8.4*	5.8	7.6*	3.8	5.5	2.4	3.7	2.2	3.0*
	Outriggers	Blade	8.4*	8.4*	6.3	7.6*	4.1	6.3*	2.6	4.0*	2.5	3.0*
3.0	Blade	-	10.1	13.1*	5.6	8.2	3.7	5.4	2.4	3.7	2.0	3.1*
	Outriggers	Blade	10.1	13.1*	6.1	9.1*	4.1	6.8*	2.6	5.7*	2.2	3.1*
1.5	Blade	-	9.8	13.0*	5.5	8.1	3.7	5.4	2.3	3.6	1.9	3.0
	Outriggers	Blade	9.8	13.0*	6.0	10.1*	4.0	7.3*	2.5	5.8*	2.1	3.3*
0	Blade	-	9.7	15.0*	5.3	8.1	3.4	5.2	2.2	3.5	1.9	3.1
	Outriggers	Blade	9.7	15.0*	5.9	10.3*	3.7	7.5*	2.4	5.8*	2.1	3.6*
-1.5	Blade	-	9.2	16.2	5.1	8.1	3.1	5.0			2.1	3.4
	Outriggers	Blade	9.2	16.2	5.1	8.1	3.1	5.0			2.1	3.4
-3.0	Blade	-	10.3	17.4*	5.2	10.6*	3.3	6.2*			2.9	4.4*
	Outriggers	Blade	10.3	17.4*	5.2	10.6*	3.3	6.2*			2.9	4.4*
-4.5	Blade	-	8.8	11.7*							5.8	7.6*
	Outriggers	Blade	8.8	11.7*							5.8	7.6*

Stick 2.45 m

m	Undercarriage stabilized		3.0m		4.5m		6.0m		7.5m		m	
	rear	front										
9.0	Blade	-									4.1*	4.1*
	Outriggers	Blade									4.1*	4.1*
7.5	Blade	-			5.1*	5.1*	3.2*	3.2*			3.1*	3.1*
	Outriggers	Blade			5.1*	5.1*	3.2*	3.2*			3.1*	3.1*
6.0	Blade	-			5.3*	5.3*	3.8	5.1*			2.6	2.8*
	Outriggers	Blade			5.3*	5.3*	5.1*	5.1*			2.8*	2.8*
4.5	Blade	-	6.6*	6.6*	5.8	6.6*	3.8	5.5	2.4	3.7	2.1	2.7*
	Outriggers	Blade	6.6*	6.6*	6.3	6.6*	4.1	6.1*	2.7	4.3*	2.4	2.7*
3.0	Blade	-	10.1	13.3*	5.6	8.2	3.7	5.4	2.4	3.7	1.9	2.8*
	Outriggers	Blade	10.1	13.3*	6.1	8.8*	4.1	6.7*	2.7	5.6*	2.1	2.8*
1.5	Blade	-	9.8	12.9*	5.4	8.1	3.7	5.3	2.3	3.6	1.8	2.9
	Outriggers	Blade	9.8	12.9*	5.9	10.0*	4.0	7.2*	2.6	5.8*	2.0	2.9*
0	Blade	-	9.7	14.6*	5.3	8.1	3.5	5.3	2.2	3.5	1.8	3.0
	Outriggers	Blade	9.7	14.6*	5.9	10.3*	3.8	7.4*	2.4	5.8*	2.0	3.3*
-1.5	Blade	-	9.2	16.0	5.0	8.1	3.1	5.0	2.1	3.4	2.0	3.2
	Outriggers	Blade	9.2	16.0	5.0	8.1	3.1	5.0	2.1	3.4	2.0	3.2
-3.0	Blade	-	10.2	17.2*	5.3	10.7*	3.3	6.7*			2.7	4.4*
	Outriggers	Blade	10.2	17.2*	5.3	10.7*	3.3	6.7*			2.7	4.4*
-4.5	Blade	-	8.8	13.2*	4.6	6.4*					4.4	6.1*
	Outriggers	Blade	8.8	13.2*	4.6	6.4*					4.4	6.1*

Height Can be slewed through 360° In longitudinal position of undercarriage Max. reach * Limited by hydr. capacity

The lift capacities on the load hook of the Liebherr quick coupler SWA 48 without attachment are stated in metric tons (t) and are valid on a firm, level supporting surface with blocked oscillating axle. These capacities can be slewed through 360° with the undercarriage in the transverse position. Capacities in the longitudinal position of the undercarriage (±15°) are specified over the steering axle with the stabilizers raised and over the rigid axle with the stabilizers down. The values apply when the adjusting cylinder is in the optimal position. Indicated loads based on the ISO 10567 standard and do not exceed 75% of tipping or 87% of hydraulic capacity, or are limited by the permissible load of the load hook on the quick coupler (max. 12 t). Without the quick coupler, lift capacities will increase by up to 226 kg.

In accordance with the harmonised European Standard EN 474-5, hydraulic excavators used for lifting operations must be equipped with pipe fracture safety valves, an overload warning device, a load hook and a lift capacity chart.

Stick 2.65 m

m	Undercarriage stabilized		3.0m		4.5m		6.0m		7.5m		m
	rear	front									
9.0	-	-							3.6*	3.6*	4.3
	Blade	-							3.6*	3.6*	
7.5	Outriggers	Blade							2.9*	2.9*	6.3
	-	-							2.9*	2.9*	
6.0	Blade	-							2.4	2.6*	7.4
	Outriggers	Blade							2.6*	2.6*	
4.5	-	-							2.0	2.5*	8.1
	Blade	-							2.2	2.5*	
3.0	Outriggers	Blade							1.8	2.5*	8.5
	-	-							1.8	2.5*	
1.5	Blade	-							1.7	2.7*	8.6
	Outriggers	Blade							1.7	2.7*	
0	-	-							1.7	2.8	8.4
	Blade	-							1.9	3.0*	
-1.5	Outriggers	Blade							1.9	3.1	7.9
	-	-							2.2	3.7	
-3.0	Blade	-							2.5	4.3*	7.0
	Outriggers	Blade							3.9	4.3*	
-4.5	-	-							3.7	5.3*	5.1
	Blade	-							4.1	5.3*	
	Outriggers	Blade							5.2*	5.2*	
	-	-									

Stick 3.05 m

m	Undercarriage stabilized		3.0m		4.5m		6.0m		7.5m		m
	rear	front									
9.0	-	-									4.7
	Blade	-									
7.5	Outriggers	Blade									6.5
	-	-									
6.0	Blade	-									7.6
	Outriggers	Blade									
4.5	-	-									8.3
	Blade	-									
3.0	Outriggers	Blade									8.7
	-	-									
1.5	Blade	-									8.7
	Outriggers	Blade									
0	-	-									8.5
	Blade	-									
-1.5	Outriggers	Blade									8.1
	-	-									
-3.0	Blade	-									7.2
	Outriggers	Blade									
-4.5	-	-									5.8
	Blade	-									
	Outriggers	Blade									
	-	-									

Height Can be slewed through 360° In longitudinal position of undercarriage Max. reach * Limited by hydr. capacity

The lift capacities on the load hook of the Liebherr quick coupler SWA 48 without attachment are stated in metric tons (t) and are valid on a firm, level supporting surface with blocked oscillating axle. These capacities can be slewed through 360° with the undercarriage in the transverse position. Capacities in the longitudinal position of the undercarriage ($\pm 15^\circ$) are specified over the steering axle with the stabilizers raised and over the rigid axle with the stabilizers down. The values apply when the adjusting cylinder is in the optimal position. Indicated loads based on the ISO 10567 standard and do not exceed 75% of tipping or 87% of hydraulic capacity, or are limited by the permissible load of the load hook on the quick coupler (max. 12 t). Without the quick coupler, lift capacities will increase by up to 226 kg.

In accordance with the harmonised European Standard EN 474-5, hydraulic excavators used for lifting operations must be equipped with pipe fracture safety valves, an overload warning device, a load hook and a lift capacity chart.

Backhoe bucket

with mono boom 5.60 m

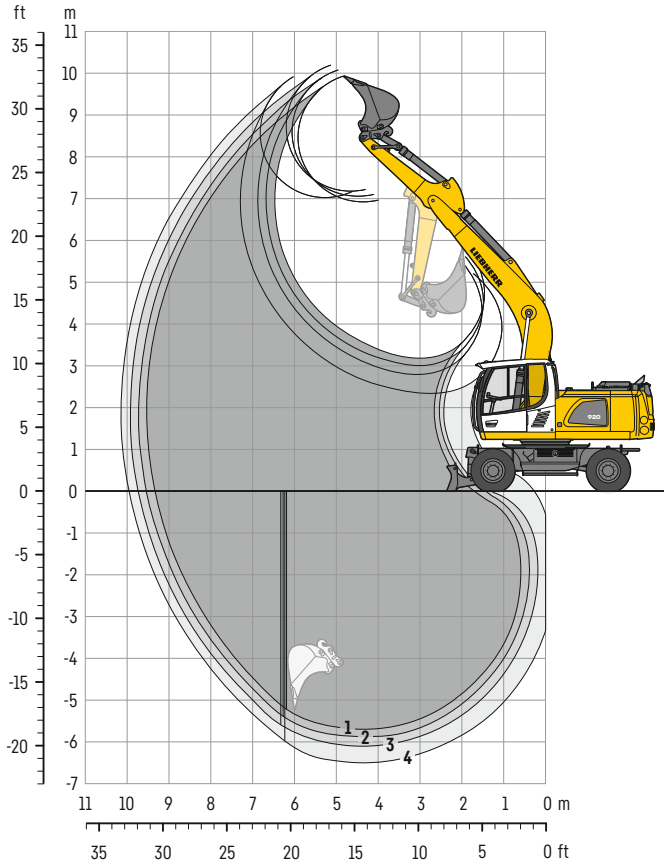

Digging envelope

with quick coupler		1	2	3	4
Stick length	m	2.25	2.45	2.65	3.05
Max. digging depth	m	5.70	5.90	6.10	6.50
Max. reach at ground level	m	9.35	9.55	9.75	9.95
Max. dumping height	m	6.95	7.05	7.20	7.05
Max. teeth height	m	9.95	10.00	10.20	9.95
Min. equipment radius	m	3.38	3.41	3.44	3.43

Digging forces

without quick coupler		1	2	3	4
Max. digging force (ISO 6015)	kN	98.7	92.6	87.2	78.2
	t	10.1	9.4	8.9	8.0
Max. breakout force (ISO 6015)	kN	124.6	124.6	124.6	124.6
	t	12.7	12.7	12.7	12.7

Max. breakout force with ripper bucket

156.9kN (16.0t)

Operating weight

The operating weight includes the basic machine with 8 tyres plus intermediate rings, mono boom 5.60 m, stick 2.45 m, quick coupler SWA 48 and bucket 1,050 mm / 0.80 m³.

Undercarriage versions	Weight (kg)
A 920 Litronic with rear blade	18,300
A 920 Litronic with rear outriggers + front blade	20,000
A 920 Litronic with rear + front outriggers	20,100

Buckets Machine stability per ISO 10567* (75% of tipping capacity)

Cutting width mm	Capacity ISO 7451 ¹⁾ m ³	Weight kg	Stabilizers raised				Rear blade down				Rear outriggers + front blade down				Rear + front outriggers down			
			Stick length (m)				Stick length (m)				Stick length (m)				Stick length (m)			
			2.25	2.45	2.65	3.05	2.25	2.45	2.65	3.05	2.25	2.45	2.65	3.05	2.25	2.45	2.65	3.05
650 ²⁾	0.55	520	■	■	■	■	■	■	■	■	■	■	■	■	■	■	■	■
850 ²⁾	0.60	560	■	■	■	■	■	■	■	■	■	■	■	■	■	■	■	■
1,050 ²⁾	0.80	640	■	■	△	△	■	■	■	△	■	■	■	■	■	■	■	■
1,250 ²⁾	1.00	730	△	-	-	-	△	△	△	-	■	■	■	■	■	■	■	■
1,400 ²⁾	1.15	800	-	-	-	-	-	-	-	-	■	■	■	△	■	■	■	△
650 ³⁾	0.55	580	■	■	■	■	■	■	■	■	■	■	■	■	■	■	■	■
850 ³⁾	0.60	620	■	■	■	■	■	■	■	■	■	■	■	■	■	■	■	■
1,050 ³⁾	0.80	710	■	△	△	△	■	■	■	△	■	■	■	■	■	■	■	■
1,250 ³⁾	1.00	810	-	-	-	-	△	△	-	-	■	■	■	■	■	■	■	■
1,400 ³⁾	1.15	890	-	-	-	-	-	-	-	-	■	■	■	△	■	■	■	△
650 ⁴⁾	0.60	540	■	■	■	■	■	■	■	■	■	■	■	■	■	■	■	■
850 ⁴⁾	0.65	590	■	■	■	■	■	■	■	■	■	■	■	■	■	■	■	■
1,050 ⁴⁾	0.85	670	△	△	△	-	■	■	■	△	■	■	■	■	■	■	■	■
1,250 ⁴⁾	1.05	770	-	-	-	-	△	△	-	-	■	■	■	■	■	■	■	■
1,400 ⁴⁾	1.20	840	-	-	-	-	-	-	-	-	■	■	■	△	■	■	■	△

* Indicated loads are based on ISO 10567 and do not exceed 75% of tipping or 87% of hydraulic capacity, max. stick length without quick coupler, lifted 360° on firm with blocked oscillating axle

¹⁾ comparable with SAE (heaped)

²⁾ Bucket with teeth ³⁾ Bucket with teeth in HD version ⁴⁾ Bucket with cutting edge (also available in HD version)

Max. material weight ■ = ≤ 1.8t/m³, ■ = ≤ 1.5t/m³, △ = ≤ 1.2t/m³, - = not authorised

Lift capacities

with mono boom 5.60 m

Stick 2.25 m

m	Undercarriage stabilized		3.0m		4.5m		6.0m		7.5m		m	
	rear	front										
7.5	-	-									2.6*	2.6*
	Blade	-									2.6*	2.6*
	Outriggers	Blade									2.6*	2.6*
6.0	-	-					3.1	5.1			2.2	2.4*
	Blade	-					3.3	5.1*			2.4*	2.4*
	Outriggers	Blade					5.1	5.1*			2.4*	2.4*
4.5	-	-			4.6	6.7*	2.9	4.9	2.0	3.4	1.8	2.3*
	Blade	-			5.0	6.7*	3.2	5.6*	2.2	4.0*	2.0	2.3*
	Outriggers	Blade			6.7*	6.7*	5.0	5.6*	3.4	4.0*	2.3*	2.3*
3.0	-	-			4.1	7.3	2.7	4.7	1.9	3.3	1.6	2.4*
	Blade	-			4.5	8.2*	3.0	6.2*	2.1	5.2*	1.8	2.4*
	Outriggers	Blade			7.3	8.2*	4.7	6.2*	3.3	5.2*	2.4*	2.4*
1.5	-	-			3.6	6.8	2.5	4.4	1.8	3.2	1.5	2.6*
	Blade	-			4.1	9.4*	2.7	6.8*	2.0	5.5*	1.7	2.6*
	Outriggers	Blade			6.8	9.4*	4.5	6.8*	3.2	5.5*	2.6*	2.6*
0	-	-			8.4	9.4*	5.4	6.8*	3.9	5.5*	2.6*	2.6*
	Blade	-			3.4	6.6	2.3	4.3	1.7	3.1	1.5	2.8
	Outriggers	Blade			3.9	9.7*	2.6	7.1*	1.9	5.5*	1.7	2.9*
-1.5	-	-	6.3	8.4*	3.4	6.5	2.3	4.2	1.7	3.1	1.7	3.1
	Blade	-	7.2	8.4*	3.8	9.2*	2.5	6.8*	1.9	3.6*	1.9	3.5*
	Outriggers	Blade	8.4*	8.4*	6.5	9.2*	4.3	6.8*	3.1	3.6*	3.1	3.5*
-3.0	-	-	8.4*	8.4*	8.1	9.2*	5.2	6.8*	3.6*	3.6*	3.5*	3.5*
	Blade	-	6.5	10.5*	3.5	6.6	2.3	4.3			2.1	3.8
	Outriggers	Blade	7.4	10.5*	3.9	7.8*	2.6	5.8*			2.3	4.8*
-4.5	-	-	10.5*	10.5*	6.6	7.8*	4.3	5.7*			3.8	4.8*
	Blade	-	10.5*	10.5*	7.8*	7.8*	5.2	5.7*			4.6	4.8*
	Outriggers	Blade			3.7	5.1*					3.2	4.2*
-7.5	-	-			4.1	5.1*					3.5	4.2*
	Blade	-			5.0*	5.0*					4.2*	4.2*
	Outriggers	Blade			5.0*	5.0*					4.2*	4.2*

Stick 2.45 m

m	Undercarriage stabilized		3.0m		4.5m		6.0m		7.5m		m	
	rear	front										
7.5	-	-					3.1	3.3*			2.4*	2.4*
	Blade	-					3.3*	3.3*			2.4*	2.4*
	Outriggers	Blade					3.3*	3.3*			2.4*	2.4*
6.0	-	-					3.1	5.0*			2.1	2.2*
	Blade	-					3.4	5.0*			2.2*	2.2*
	Outriggers	Blade					5.0*	5.0*			2.2*	2.2*
4.5	-	-			4.6	6.4*	2.9	4.9	2.0	3.4	1.7	2.1*
	Blade	-			5.1	6.4*	3.2	5.4*	2.2	4.3*	1.9	2.1*
	Outriggers	Blade			6.4*	6.4*	5.0	5.4*	3.4	4.3*	2.1*	2.1*
3.0	-	-			4.1	7.3	2.7	4.7	1.9	3.3	1.5	2.2*
	Blade	-			4.5	8.0*	3.0	6.1*	2.1	5.1*	1.7	2.2*
	Outriggers	Blade			7.4	8.0*	4.7	6.1*	3.3	5.1*	2.2*	2.2*
1.5	-	-			3.6	6.8	2.4	4.4	1.7	3.2	1.4	2.3*
	Blade	-			4.1	9.2*	2.7	6.7*	2.0	5.4*	1.6	2.3*
	Outriggers	Blade			6.8	9.2*	4.5	6.7*	3.2	5.4*	2.3*	2.3*
0	-	-			8.4	9.2*	5.4	6.7*	3.8	5.4*	2.3*	2.3*
	Blade	-			4.8*	4.8*	3.4	6.5	2.3	4.2	1.7	3.1
	Outriggers	Blade			4.8*	4.8*	3.8	9.7*	2.6	7.0*	1.9	5.5*
-1.5	-	-			4.8*	4.8*	6.6	9.7*	4.3	7.0*	3.1	5.5*
	Blade	-			4.8*	4.8*	8.1	9.7*	5.2	7.0*	3.8	5.5*
	Outriggers	Blade			6.2	8.1*	3.3	6.5	2.2	4.2	1.6	3.0
-3.0	-	-			7.1	8.1*	3.8	9.2*	2.5	6.8*	1.8	5.1*
	Blade	-			8.1*	8.1*	6.5	9.2*	4.2	6.8*	3.1	5.1*
	Outriggers	Blade			8.1*	8.1*	8.0	9.2*	5.1	6.8*	3.7	5.1*
-4.5	-	-			6.4	11.0*	3.4	6.5	2.3	4.2	1.9	3.5
	Blade	-			7.3	11.0*	3.8	8.0*	2.5	5.9*	2.2	4.2*
	Outriggers	Blade			11.0*	11.0*	6.6	8.0*	4.3	5.9*	3.6	4.2*
-7.5	-	-			11.0*	11.0*	8.0*	8.0*	5.2	5.9*	4.2*	4.2*
	Blade	-			3.6	5.5*					2.8	4.2*
	Outriggers	Blade			4.0	5.5*					3.2	4.2*

Height Can be slewed through 360° In longitudinal position of undercarriage Max. reach * Limited by hydr. capacity

The lift capacities on the load hook of the Liebherr quick coupler SWA 48 without attachment are stated in metric tons (t) and are valid on a firm, level supporting surface with blocked oscillating axle. These capacities can be slewed through 360° with the undercarriage in the transverse position. Capacities in the longitudinal position of the undercarriage (±15°) are specified over the steering axle with the stabilizers raised and over the rigid axle with the stabilizers down. Indicated loads based on the ISO 10567 standard and do not exceed 75% of tipping or 87% of hydraulic capacity, or are limited by the permissible load of the load hook on the quick coupler (max. 12t). Without the quick coupler, lift capacities will increase by up to 226 kg. In accordance with the harmonised European Standard EN 474-5, hydraulic excavators used for lifting operations must be equipped with pipe fracture safety valves, an overload warning device, a load hook and a lift capacity chart.

Lift capacities

with mono boom 5.60 m

Stick 2.65 m

m	Undercarriage stabilized		3.0 m		4.5 m		6.0 m		7.5 m		m
	rear	front									
7.5	-	-			3.1	3.6*			2.2*	2.2*	6.5
	Blade	-			3.4	3.6*			2.2*	2.2*	
	Outriggers	Blade			3.6*	3.6*			2.2*	2.2*	
6.0	-	-			3.1	4.8*	2.0	2.4*	2.0	2.0*	7.6
	Blade	-			3.4	4.8*	2.2	2.4*	2.0*	2.0*	
	Outriggers	Blade			4.8*	4.8*	2.4*	2.4*	2.0*	2.0*	
4.5	-	-			2.9	4.9	2.0	3.4	1.6	1.9*	8.2
	Blade	-			3.2	5.2*	2.2	4.3*	1.8	1.9*	
	Outriggers	Blade			5.0	5.2*	3.4	4.3*	1.9*	1.9*	
3.0	-	-			4.1	7.4	2.7	4.7	1.8	3.3	8.6
	Blade	-			4.6	7.7*	3.0	5.9*	2.1	5.0*	
	Outriggers	Blade			7.4	7.7*	4.7	5.9*	3.3	5.0*	
1.5	-	-			3.6	6.8	2.4	4.4	1.7	3.1	8.6
	Blade	-			4.1	9.1*	2.7	6.6*	1.9	5.3*	
	Outriggers	Blade			6.8	9.1*	4.5	6.6*	3.2	5.3*	
0	-	-			4.9*	4.9*	3.4	6.5	2.3	4.2	8.4
	Blade	-			4.9*	4.9*	3.8	9.6*	2.5	6.9*	
	Outriggers	Blade			4.9*	4.9*	6.5	9.6*	4.3	6.9*	
-1.5	-	-			6.1	7.8*	3.3	6.4	2.2	4.1	7.9
	Blade	-			7.0	7.8*	3.7	9.3*	2.5	6.8*	
	Outriggers	Blade			7.8*	7.8*	6.4	9.3*	4.2	6.8*	
-3.0	-	-			6.3	11.4*	3.3	6.5	2.2	4.2	7.1
	Blade	-			7.2	11.4*	3.8	8.2*	2.5	6.1*	
	Outriggers	Blade			11.4*	11.4*	6.5	8.2*	4.2	6.1*	
-4.5	-	-			6.6	8.0*	3.5	5.9*			5.7
	Blade	-			7.5	8.0*	4.0	5.9*			
	Outriggers	Blade			8.0*	8.0*	5.9*	5.9*			

Stick 3.05 m

m	Undercarriage stabilized		3.0 m		4.5 m		6.0 m		7.5 m		m
	rear	front									
7.5	-	-									6.7
	Blade	-									
	Outriggers	Blade									
6.0	-	-							2.0	2.3*	7.8
	Blade	-							2.3*	2.3*	
	Outriggers	Blade							2.3*	2.3*	
4.5	-	-					2.9	4.9*	2.0	3.4	8.4
	Blade	-					3.2	4.9*	2.2	3.8*	
	Outriggers	Blade					4.9*	4.9*	3.5	3.8*	
3.0	-	-			7.7	11.3*	4.2	7.2*	2.7	4.7	8.7
	Blade	-			8.6	11.3*	4.7	7.2*	3.0	5.6*	
	Outriggers	Blade			11.3*	11.3*	7.2*	7.2*	4.8	5.6*	
1.5	-	-			5.8*	5.8*	3.7	6.9	2.4	4.4	8.8
	Blade	-			5.8*	5.8*	4.1	8.7*	2.7	6.3*	
	Outriggers	Blade			5.8*	5.8*	6.9	8.7*	4.5	6.3*	
0	-	-			6.0	6.2*	3.4	6.5	2.2	4.2	8.6
	Blade	-			6.2*	6.2*	3.8	9.5*	2.5	6.8*	
	Outriggers	Blade			6.2*	6.2*	6.5	9.5*	4.3	6.8*	
-1.5	-	-			6.0	8.2*	3.2	6.3	2.1	4.1	8.1
	Blade	-			6.9	8.2*	3.7	9.4*	2.4	6.8*	
	Outriggers	Blade			8.2*	8.2*	6.4	9.4*	4.1	6.8*	
-3.0	-	-			6.1	11.2*	3.2	6.4	2.1	4.1	7.3
	Blade	-			7.0	11.2*	3.7	8.5*	2.4	6.3*	
	Outriggers	Blade			11.2*	11.2*	6.4	8.5*	4.1	6.3*	
-4.5	-	-			6.4	9.2*	3.4	6.5			5.9
	Blade	-			7.3	9.2*	3.8	6.6*			
	Outriggers	Blade			9.1*	9.1*	6.6	6.6*			

Height Can be slewed through 360° In longitudinal position of undercarriage Max. reach * Limited by hydr. capacity

The lift capacities on the load hook of the Liebherr quick coupler SWA 48 without attachment are stated in metric tons (t) and are valid on a firm, level supporting surface with blocked oscillating axle. These capacities can be slewed through 360° with the undercarriage in the transverse position. Capacities in the longitudinal position of the undercarriage (±15°) are specified over the steering axle with the stabilizers raised and over the rigid axle with the stabilizers down. Indicated loads based on the ISO 10567 standard and do not exceed 75% of tipping or 87% of hydraulic capacity, or are limited by the permissible load of the load hook on the quick coupler (max. 12t). Without the quick coupler, lift capacities will increase by up to 226 kg. In accordance with the harmonised European Standard EN 474-5, hydraulic excavators used for lifting operations must be equipped with pipe fracture safety valves, an overload warning device, a load hook and a lift capacity chart.

Clamshell grab

with two-piece boom 5.40 m

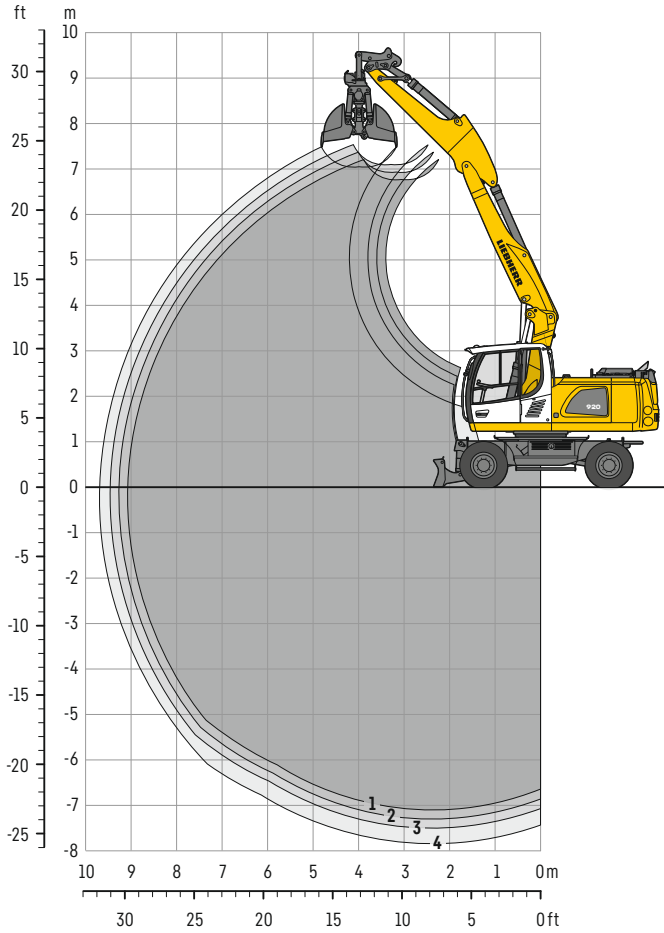

Digging envelope

with quick coupler	1	2	3	4
Stick length	m 2.25	2.45	2.65	3.05
Max. digging depth	m 7.10	7.30	7.50	7.85
Max. reach at ground level	m 9.05	9.25	9.45	9.65
Max. dumping height	m 6.80	6.95	7.10	7.05

Operating weight

The operating weight includes the basic machine with 8 tyres plus intermediate rings, two-piece boom 5.40 m, stick 2.45 m, quick coupler SWA 48 and clamshell grab GMZ 24 / 0.45 m³ (800 mm without ejector).

Undercarriage versions	Weight (kg)
A 920 Litronic with rear blade	19,600
A 920 Litronic with rear outriggers + front blade	21,500
A 920 Litronic with rear + front outriggers	21,600
A 920 EW Litronic with rear blade	19,800
A 920 EW Litronic with rear outriggers + front blade	21,700

Clamshell grabs GMZ 24 Machine stability per ISO 10567* (75% of tipping capacity)

Width of clamshells mm	Capacity m ³	Weight kg	Stabilizers raised				Rear blade down				Rear outriggers + front blade down				Rear + front outriggers down				EW Stabilizers raised				EW Rear blade down				EW Rear outriggers + front blade down								
			Stick length (m)				Stick length (m)				Stick length (m)				Stick length (m)				Stick length (m)				Stick length (m)				Stick length (m)								
			2.25	2.45	2.65	3.05	2.25	2.45	2.65	3.05	2.25	2.45	2.65	3.05	2.25	2.45	2.65	3.05	2.25	2.45	2.65	3.05	2.25	2.45	2.65	3.05	2.25	2.45	2.65	3.05	2.25	2.45	2.65	3.05	
320 ¹⁾	0.16	895	■	■	■	■	■	■	■	■	■	■	■	■	■	■	■	■	■	■	■	■	■	■	■	■	■	■	■	■	■	■	■	■	
400 ¹⁾	0.22	930	■	■	■	■	■	■	■	■	■	■	■	■	■	■	■	■	■	■	■	■	■	■	■	■	■	■	■	■	■	■	■	■	
600 ¹⁾	0.34	1,015	■	■	■	■	■	■	■	■	■	■	■	■	■	■	■	■	■	■	■	■	■	■	■	■	■	■	■	■	■	■	■	■	
800 ¹⁾	0.46	1,090	■	■	■	△	■	■	■	■	■	■	■	■	■	■	■	■	■	■	■	■	■	■	■	■	■	■	■	■	■	■	■	■	
1,000 ¹⁾	0.60	1,165	■	△	△	-	■	■	■	△	■	■	■	■	■	■	■	■	■	■	■	△	■	■	■	■	■	■	■	■	■	■	■	■	
320 ²⁾	0.16	950	■	■	■	■	■	■	■	■	■	■	■	■	■	■	■	■	■	■	■	■	■	■	■	■	■	■	■	■	■	■	■	■	
400 ²⁾	0.22	985	■	■	■	■	■	■	■	■	■	■	■	■	■	■	■	■	■	■	■	■	■	■	■	■	■	■	■	■	■	■	■	■	
600 ²⁾	0.34	1,075	■	■	■	■	■	■	■	■	■	■	■	■	■	■	■	■	■	■	■	■	■	■	■	■	■	■	■	■	■	■	■	■	
800 ²⁾	0.46	1,155	■	■	■	△	■	■	■	■	■	■	■	■	■	■	■	■	■	■	■	■	■	■	■	■	■	■	■	■	■	■	■	■	
1,000 ²⁾	0.60	1,235	△	△	-	-	■	■	△	△	■	■	■	■	■	■	■	■	■	■	■	△	△	■	■	■	■	■	■	■	■	■	■	■	■

* Indicated loads are based on ISO 10567 and do not exceed 75% of tipping or 87% of hydraulic capacity, max. stick length without quick coupler, lifted 360° on firm with blocked oscillating axle

¹⁾ without ejector

²⁾ with ejector

Max. material weight ■ = ≤ 1.8t/m³, ■ = ≤ 1.5t/m³, △ = ≤ 1.2t/m³, - = not authorised

Equipments

Clamshell grabs / tilt buckets

Clamshell grabs GMZ 24 Machine stability per ISO 10567* (75% of tipping capacity)

Width of clamshells mm	Capacity m ³	Weight kg	Stabilizers raised				Rear blade down				Rear outriggers + front blade down				Rear + front outriggers down				EW Stabilizers raised				EW Rear blade down				EW Rear outriggers + front blade down												
			Stick length (m)				Stick length (m)				Stick length (m)				Stick length (m)				Stick length (m)				Stick length (m)				Stick length (m)												
			2.25	2.45	2.65	3.05	2.25	2.45	2.65	3.05	2.25	2.45	2.65	3.05	2.25	2.45	2.65	3.05	2.25	2.45	2.65	3.05	2.25	2.45	2.65	3.05	2.25	2.45	2.65	3.05	2.25	2.45	2.65	3.05					
Two-piece boom 5.40 m (heavy counterweight)																																							
320 ¹⁾	0.16	895	■	■	■	■	■	■	■	■	■	■	■	■	■	■	-	-	-	-	■	■	■	■	■	■	■	■	■	■	■	■	■	■	■	■			
400 ¹⁾	0.22	930	■	■	■	■	■	■	■	■	■	■	■	■	■	■	-	-	-	-	■	■	■	■	■	■	■	■	■	■	■	■	■	■	■	■	■		
600 ¹⁾	0.34	1,015	■	■	■	■	■	■	■	■	■	■	■	■	■	■	-	-	-	-	■	■	■	■	■	■	■	■	■	■	■	■	■	■	■	■	■		
800 ¹⁾	0.46	1,090	■	■	■	■	■	■	■	■	■	■	■	■	■	■	-	-	-	-	■	■	■	■	■	■	■	■	■	■	■	■	■	■	■	■	■		
1,000 ¹⁾	0.60	1,165	■	△	△	-	■	■	■	■	■	■	■	■	■	■	-	-	-	-	■	■	■	■	■	■	■	■	■	■	■	■	■	■	■	■	■		
320 ²⁾	0.16	950	■	■	■	■	■	■	■	■	■	■	■	■	■	■	-	-	-	-	■	■	■	■	■	■	■	■	■	■	■	■	■	■	■	■	■		
400 ²⁾	0.22	985	■	■	■	■	■	■	■	■	■	■	■	■	■	■	-	-	-	-	■	■	■	■	■	■	■	■	■	■	■	■	■	■	■	■	■	■	
600 ²⁾	0.34	1,075	■	■	■	■	■	■	■	■	■	■	■	■	■	■	-	-	-	-	■	■	■	■	■	■	■	■	■	■	■	■	■	■	■	■	■	■	
800 ²⁾	0.46	1,155	■	■	■	■	■	■	■	■	■	■	■	■	■	■	-	-	-	-	■	■	■	■	■	■	■	■	■	■	■	■	■	■	■	■	■	■	
1,000 ²⁾	0.60	1,235	△	△	-	-	■	■	■	■	■	■	■	■	■	■	-	-	-	-	■	■	■	■	■	■	■	■	■	■	■	■	■	■	■	■	■	■	
Mono boom 5.60 m																																							
320 ¹⁾	0.16	895	■	■	■	■	■	■	■	■	■	■	■	■	■	■	-	-	-	-	-	-	-	-	-	-	-	-	-	-	-	-	-	-	-	-	-		
400 ¹⁾	0.22	930	■	■	■	■	■	■	■	■	■	■	■	■	■	■	-	-	-	-	-	-	-	-	-	-	-	-	-	-	-	-	-	-	-	-	-	-	
600 ¹⁾	0.34	1,015	■	■	■	■	■	■	■	■	■	■	■	■	■	■	-	-	-	-	-	-	-	-	-	-	-	-	-	-	-	-	-	-	-	-	-	-	-
800 ¹⁾	0.46	1,090	■	■	■	■	■	■	■	■	■	■	■	■	■	■	-	-	-	-	-	-	-	-	-	-	-	-	-	-	-	-	-	-	-	-	-	-	-
1,000 ¹⁾	0.60	1,165	■	△	△	-	■	■	■	■	■	■	■	■	■	■	-	-	-	-	-	-	-	-	-	-	-	-	-	-	-	-	-	-	-	-	-	-	-
320 ²⁾	0.16	950	■	■	■	■	■	■	■	■	■	■	■	■	■	■	-	-	-	-	-	-	-	-	-	-	-	-	-	-	-	-	-	-	-	-	-	-	-
400 ²⁾	0.22	985	■	■	■	■	■	■	■	■	■	■	■	■	■	■	-	-	-	-	-	-	-	-	-	-	-	-	-	-	-	-	-	-	-	-	-	-	-
600 ²⁾	0.34	1,075	■	■	■	■	■	■	■	■	■	■	■	■	■	■	-	-	-	-	-	-	-	-	-	-	-	-	-	-	-	-	-	-	-	-	-	-	-
800 ²⁾	0.46	1,155	■	■	■	■	■	■	■	■	■	■	■	■	■	■	-	-	-	-	-	-	-	-	-	-	-	-	-	-	-	-	-	-	-	-	-	-	-
1,000 ²⁾	0.60	1,235	△	△	-	-	■	■	■	■	■	■	■	■	■	■	-	-	-	-	-	-	-	-	-	-	-	-	-	-	-	-	-	-	-	-	-	-	-

* Indicated loads are based on ISO 10567 and do not exceed 75% of tipping or 87% of hydraulic capacity, max. stick length without quick coupler, lifted 360° on firm with blocked oscillating axle

¹⁾ without ejector

²⁾ with ejector

Max. material weight ■ = ≤ 1.8t/m³, ■ = ≤ 1.5t/m³, △ = ≤ 1.2t/m³, - = not authorised

Tilt buckets Machine stability per ISO 10567* (75% of tipping capacity)

Cutting width mm	Capacity ISO 7451 ¹⁾ m ³	Weight kg	Stabilizers raised				Rear blade down				Rear outriggers + front blade down				Rear + front outriggers down				EW Stabilizers raised				EW Rear blade down				EW Rear outriggers + front blade down													
			Stick length (m)				Stick length (m)				Stick length (m)				Stick length (m)				Stick length (m)				Stick length (m)				Stick length (m)													
			2.25	2.45	2.65	3.05	2.25	2.45	2.65	3.05	2.25	2.45	2.65	3.05	2.25	2.45	2.65	3.05	2.25	2.45	2.65	3.05	2.25	2.45	2.65	3.05	2.25	2.45	2.65	3.05	2.25	2.45	2.65	3.05						
Two-piece boom 5.40 m																																								
1,500 ²⁾	1.20	970	-	-	-	-	-	-	-	-	-	-	-	-	-	-	-	-	-	-	-	-	-	-	-	-	-	-	-	-	-	-	-	-	-	-	-			
1,600 ²⁾	0.80	820	△	△	△	-	■	■	■	■	■	■	■	■	■	■	■	■	■	■	■	■	■	■	■	■	■	■	■	■	■	■	■	■	■	■	■	■	■	
1,600 ²⁾	1.00	890	-	-	-	-	△	△	-	-	■	■	■	■	■	■	■	■	■	■	■	■	■	■	■	■	■	■	■	■	■	■	■	■	■	■	■	■	■	
Two-piece boom 5.40 m (heavy counterweight)																																								
1,500 ²⁾	1.20	970	-	-	-	-	-	-	-	-	-	-	-	-	-	-	-	-	-	-	-	-	-	-	-	-	-	-	-	-	-	-	-	-	-	-	-	-		
1,600 ²⁾	0.80	820	△	△	△	-	■	■	■	■	■	■	■	■	■	■	-	-	-	-	■	■	■	■	■	■	■	■	■	■	■	■	■	■	■	■	■	■	■	■
1,600 ²⁾	1.00	890	-	-	-	-	△	△	-	-	■	■	■	■	■	■	-	-	-	-	■	■	■	■	■	■	■	■	■	■	■	■	■	■	■	■	■	■	■	■
Mono boom 5.60 m																																								
1,500 ²⁾	1.20	970	-	-	-	-	-	-	-	-	-	-	-	-	-	-	-	-	-	-	-	-	-	-	-	-	-	-	-	-	-	-	-	-	-	-	-	-		
1,600 ²⁾	0.80	820	△	△	△	-	■	■	■	■	■	■	■	■	■	■	-	-	-	-	-	-	-	-	-	-	-	-	-	-	-	-	-	-	-	-	-	-	-	-
1,600 ²⁾	1.00	890	-	-	-	-	△	△	-	-	■	■	■	■	■	■	-	-	-	-	-	-	-	-	-	-	-	-	-	-	-	-	-	-	-	-	-	-	-	-

* Indicated loads are based on ISO 10567 and do not exceed 75% of tipping or 87% of hydraulic capacity, max. stick length without quick coupler, lifted 360° on firm with blocked oscillating axle

¹⁾ comparable with SAE (heaped)

²⁾ with 2 x 50° rotator

Max. material weight ■ = ≤ 1.8t/m³, ■ = ≤ 1.5t/m³, △ = ≤ 1.2t/m³, - = not authorised

Equipment

Undercarriage

Dual-circuit braking system	●
Rear stabilizer blade	+
Rear stabilizer blade + front outriggers ²⁾	+
Trailer coupling with bolt, automatic	+
Digging brake, automatic	●
Tyres (twin tyres) Liebherr EM 22 290/90-20	+
Individual control outriggers	+
Travel speed levels (four)	●
Hydraulic connection for tipping the trailer	+
Mudguards (rear and front) ¹⁾	+
Load holding valve on each stabilization cylinder	●
Powershift transmission, semiautomatic	●
Parking brake, maintenance-free	●
Rear outriggers + front stabilizer blade ²⁾	+
Rear + front outriggers ³⁾	+
Tyres, variants	+
Protection for piston rods, stabilizer cylinder	+
Speeder**	+
Storage compartment left	●
Storage compartment right	+
Power socket for lighting extension coupling, 24V (rear)	+
Undercarriage EW 2.75 m / 9'	+
Tool equipment, extended	+

Upper carriage

Upper carriage rear light, 2 pieces, LED	+
Upper carriage right side light, 1 piece, LED	+
Heavy counterweight	+
Standard counterweight	●
Refuelling system with filling pump	+
Main battery switch for electrical system	●
Engine hood with gas spring	●
Amber beacon, at upper carriage, LED double flash	+
Service doors, lockable	●

Hydraulic system

Shut-off valve between hydraulic tank and pump(s)	●
Pressure test fittings	●
Accumulator for controlled lowering of the equipment with the engine shut down	●
Hydraulic oil filter with integrated microfilter	●
Liebherr hydraulic oil from -20 °C to +40 °C	●
Liebherr hydraulic oil, biologically degradable	+
Liebherr hydraulic oil, specially for warm or cold regions	+
Bypass filter	+
Switchover high pressure circuit and tipping cylinder	+
Switchover high pressure circuit and two-piece boom	+

Diesel engine

Fuel anti-theft device	+
Liebherr particle filter (Stage V)	●
Reversible fan drive, fully automatic	+
Air pre-filter with dust discharge	+
Automatic engine shut-down (time adjustable)	+
Preheating fuel	+
Preheating coolant	+
Preheating engine oil	+

Cab

Storage compartment	●
Stabilizer, proportional control on left joystick	●
Cab lights rear, LED	+
Cab lights front, LED (above rain cover)	+
Cab lights front, LED (under rain cover)	+
Exterior mirror, electrical adjustable, with heating	+
Mechanical hour meters, readable from outside the cab	●
Roof window made from impact-resistant laminated safety glass	+
Slewing gear brake Comfort, button on the right joystick	+
Operator's seat Standard	●
Operator's seat Comfort	+
Operator's seat Premium	+
Driving alarm (acoustic signal is emitted during travel, can be switched ON / OFF)	+
Fire extinguisher	+
Front screen made from impact-resistant laminated safety glass – not adjustable	+
Windscreen retractable (including upper part)	●
Intermittent windscreen wiper with wiper washer	●
Cruise control	●
Rubber floor mat, removable	●
Dome light	●
Joystick steering	+
Joysticks Premium	+
Coat hook	●
Automatic air conditioning	●
Fuel consumption indicator	●
Electric cooler	+
Steering wheel, wide version (cost-neutral option)	+
Steering column telescopic	●
LiDAT, vehicle fleet management	●
Lightbar on cab, LED	+
Emergency exit rear window	●
Positioning swing brake	+
Proportional control	●
Radio Comfort, control via display with handsfree set	+
Preparation for radio installation	●
Rain cover over front window opening	●
ROPS cab protection	●
Back-up alarm (acoustic signal is emitted traveling backward, can not be switched off)	+
Amber beacon, on cab, LED double flash	+
Tinted windows	●
Windscreen wiper, roof	+
Windshield wiper, entire windscreen	●
Door with sliding window	●
FOPS top guard	+
FGPS front guard	+
Right side window and windshield made from laminated safety glass	●
Sun visor	+
Sun blind	●
Auxiliary heating, adjustable (week time switch)	+
Left control console, folding	●
SuperFinish	+
Electronic immobilizer	+
Cigarette lighter	●



Equipment

Boom lights, 2 pieces, halogen	●
Boom lights, 2 pieces, LED	+
Stick lights, 2 pieces, LED	+
Travel vibration damper	+
High pressure circuit incl. unpressurised return line and Tool Control	+
Electronic lift limitation	+
Security for hoist cylinder for hydraulic attachments	+
Load holding valve tipping cylinder	+
Load holding valve tipping cylinder, both sides	+
Load lug on stick	+
Leak oil line, additional for attachments	+
Liebherr ditch cleaning bucket	+
Liebherr quick coupler, hydraulic or mechanical	+
Liebherr tilt bucket	+
Liebherr tiltrotator	+
Liebherr sorting grab	+
Liebherr backhoe bucket	+
Liebherr-Tilt-Unit (LiTiU)	+
Liebherr tooth system	+
Liebherr clamshell grab	+
Medium pressure circuit incl. lines	+
Mono boom	+
Pipe fracture safety valves hoist cylinders	●
Pipe fracture safety valve stick cylinder	●
Return line, pressureless (in high pressure circuit option included)	+
Hose quick coupling at end of stick	●
Hose protection for Solidlink	+
Quick coupling system Solidlink	+
Protection for piston rod, tipping cylinder	+
Protection for bottom side of stick	+
Tool Control, 20 attachment adjustments selectable over the display	+
Overload warning device	●
Two-piece boom	+
Offset two-piece boom	+



Complete machine

Machine guidance system	
Machine guidance 2D iCON IXE2 passive Leica designed for Liebherr	+
Machine guidance 3D iCON IXE3 passive Leica designed for Liebherr	+
Preparation	+
Lubrication	
Lubrication undercarriage, manually - decentralised (grease points)	●
Lubrication undercarriage, manually - centralised (one grease point)	+
Central lubrication system for uppercarriage and equipment, automatically (without quick coupler and connecting link)*	●
Centralised lubrication extended for quick coupler	+
Centralised lubrication extended for connecting link	+
Special coating	
Custom painting for attachments	+
Special coating, variants	+
Monitoring	
Rear view monitoring with camera	●
Side view monitoring with camera	●
Skyview 360° (side camera not available)	+

● = Standard, + = Option

* = country-dependent, ** = depending upon the country partially only 25 km/h permitted

¹⁾ only available with undercarriage version "stabilizer blade rear"; ²⁾ only available with "heavy counterweight" upon request, ³⁾ not available with "heavy counterweight"

Options and / or special equipment, supplied by vendors other than Liebherr, are only to be installed with the knowledge and approval of Liebherr in order to retain warranty.

The Liebherr Group



Global and independent: more than 70 years of success

Liebherr was founded in 1949 when, with the development of the world's first mobile tower crane, Hans Liebherr laid the foundations for a family-run company which now has more than 50,000 employees and comprises over 150 companies across every continent. The holding company of the Group is Liebherr-International AG in Bulle, Switzerland, whose shareholders are exclusively members of the Liebherr family.

Technology leadership and pioneering spirit

Liebherr is a pioneer and its forward-looking approach has seen it make important contributions to technology history over a wide variety of industries. Employees throughout the world continue to share the courage of the company founder, sharing a passion to produce innovative products and a determination to provide world-leading equipment and machinery.

Diversified product programme

Liebherr is one of the world's biggest construction machine manufacturers and provides high-quality, user-oriented products and services. Its product programme includes earthmoving machinery, material handling technology, deep foundation machines, mining, mobile and crawler cranes, tower cranes, concrete technology, maritime cranes, aerospace and transportation systems, gear technology and automation systems, refrigerators and freezers, components and hotels.

Customised solutions and maximum customer value

Liebherr solutions are characterised by precision, implementation and longevity. The company is committed to technological excellence and to providing customers with solutions that match their needs exactly. For Liebherr, customer focus does not end with delivery of a product but continues through a comprehensive range of back-up and support services.

www.liebherr.com

Liebherr-Hydraulikbagger GmbH

Liebherrstraße 12 • 88457 Kirchdorf/Iller, Germany • Phone +49 7354 80-0 • Fax +49 7354 80-72 94
info.lhb@liebherr.com • www.liebherr.com • www.facebook.com/LiebherrConstruction