ICNh 5103

Integrated fridge-freezer with
EasyFresh and NoFrost

LIEBHERR

Fully Integrated



Fully Integrated

ICNh 5103

Pure

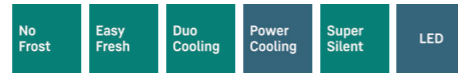

Specifications

Total Usable Volume Litres	253 litre
Fridge compartment	183 litre
Freezer compartment	70 litre
Temperature rise time	9 h
Freezing capacity in 24 hours	6 kg
Climate rating	SN-T (+10°C to +43°C)
Noise output	34 dB(A)
Frequency/voltage	50-60 Hz / 220-240 V~
Connection Rating	1.4 A 183 W

Fridge compartment

Forced air system	FreshAir activated charcoal filter
Interior light	LED ceiling light

Freezer compartment

Defrosting	automatic
Number of drawers	3 drawers, VarioSpace

Type of appliance

Type	Built-in for integrated use
Door assembly	Door on Door

Dimensions

Height	177.2-178.8 cm
Width	56-57 cm
Depth	min. 55 cm

Features

Interface	SmartDeviceBox: optional accessory (Anticipated arrival July 2022)
Door hinges	right, reversible
EAN-Nr.	4016803073352

Fully Integrated

Features



NoFrost

When you open your freezer, you want to see frozen food – and certainly not ice and frost. NoFrost protects the freezer compartment from unwanted icing, which consumes a lot of energy and can be expensive. NoFrost means no more tedious and time-consuming defrosting of the freezer compartment, more time for other things – and saving money.



EasyFresh

The guarantee of market freshness in the home is our EasyFresh-Safe. Whether it's unpackaged vegetables or fruit, this ensures optimal storage for everything. Thanks to the air-tight closure, the food causes the humidity in the safe to rise. This keeps the food fresh for a long time.



DuoCooling

DuoCooling uses two completely separate refrigeration circuits to ensure no air is exchanged between the fridge and freezer compartments. The food neither dries out nor is odour transferred. This means throwing less away, shopping less often, but saving more and greater enjoyment.



Touch display

Fingertip control: the touch display enables easy and intuitive operation of your Liebherr. All functions are clearly arranged on the display. By gently tapping a finger, for example, you can easily select the functions or check the current temperature of your refrigerator.



Space for baking tray

Do you want to keep that home-baked fruit pie fresh? Or maybe a prepared pizza to be baked later on? If so, simply slide your baking tray into your Liebherr – it has plenty of space for storing a baking tray. Really convenient – you can slide the baking tray in and out when the door is opened at 90°.



PowerCooling system

Do you want to be sure that the cold is distributed as evenly as possible in your refrigerator? If so, the PowerCooling system is what you need. The fan – as powerful as it is quiet – distributes the cold air efficiently throughout the entire refrigeration compartment.

Diagrams

Installation Diagram

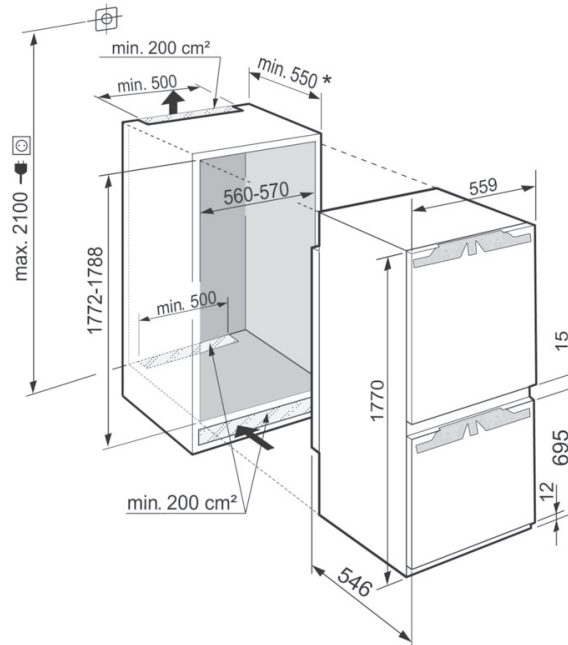

* Recommended: 560 mm

Products and their details are staged for advertising purposes. Whilst every effort is made to ensure all specifications and information in this flyer are accurate, Liebherr reserves the right to make changes without notification. Where actual appliance measurements, specifications, and ratings are crucial, we recommend that the actual appliance installation instructions that accompany each appliance be checked. Liebherr will not be liable for any loss. (09.02.2022)