LH 40 - LH 50 Port Litronic

LIEBHERR

Material handling machines

Generation

6

Operating weight

41,100–56,000 kg*

Engine

Stage V

Stage IIIA (compliant)

Tier 4 Final

Electric

* Without attachment

Performance

Power plus speed –
Redefined performance

Economy

Good investment –
Savings for long-term

Reliability

Durability and sustainability –
Quality down to the last detail

Comfort

Perfection at a glance –
When technology is comfortable

Maintainability

Efficiency bonus –
Even with maintenance and service



LH 40 M Port Litronic

Operating weight
41,100–45,500 kg* 1)

Engine
155 kW / 211 HP (Diesel)
145 kW (Electric)
Stage V
Stage IIIA (compliant)
Tier 4 Final
Electric

System performance
233 kW (Diesel)
223 kW (Electric)

* Without attachment

1) Different operating weight with electric drive



LH 40 C Port Litronic

Operating weight
44,900–50,300 kg* 1)

Engine
155 kW / 211 HP (Diesel)
145 kW (Electric)
Stage V
Stage IIIA (compliant)
Tier 4 Final
Electric

System performance
233 kW (Diesel)
223 kW (Electric)

LH 50 M High Rise Port Litronic

Operating weight
46,000–48,500 kg*

Engine
155 kW / 211 HP
Stage V
Stage IIIA (compliant)
Tier 4 Final

System performance
233 kW

LH 50 C High Rise Port Litronic

Operating weight
52,500–56,000 kg*

Engine
155 kW / 211 HP
Stage V
Stage IIIA (compliant)
Tier 4 Final

System performance
233 kW

Technical data

Diesel engine

Rating per ISO 9249	155 kW (211 HP) at 1,800 RPM
Model	Liebherr D934
Type	4 cylinder in-line
Bore / Stroke	122 / 150 mm
Displacement	7.0 l
Engine operation	4-stroke diesel Common-Rail Turbo-charged and after-cooled Reduced emissions
Air cleaner	Dry-type air cleaner with pre-cleaner, primary and safety elements
Engine idling	Sensor controlled
Electrical system	
Voltage	24 V
Batteries	2 x 180 Ah / 12 V
Alternator	Three-phase current 28 V / 140 A
Stage V	
Harmful emissions values	According to regulation (EU) 2016/1628
Emission control	Liebherr-SCR Filter technology
Fuel tank	453 l
Urea tank	65 l
Stage IIIA (compliant)	
Harmful emissions values	In accordance with ECE-R.96 Power Band H
Fuel tank	453 l
Tier 4 Final	
Harmful emissions values	In accordance with 40CFR1039 (EPA) / 13CCR (CARB)
Emission control	Liebherr-SCR technology
Fuel tank	453 l
Urea tank	65 l

Electric motor

Rating	145 kW at 1,800 RPM
Type	Three-phase squirrel cage motor
Secondary electric motor	Electric motor auxiliary equipment (air-conditioning compressor, alternator 24 V) 15 kW
Electrical system energy supply	Frequency converter fed drive system Heavy-duty version
Supply voltage	
Low voltage	380 V, 400 V
Frequency	50 / 60 Hz
Engine idling	Sensor controlled
Electrical system	Battery-assisted Control system, lighting, diagnostics system
Voltage	24 V
Batteries	2 x 135 Ah / 12 V
Alternator	Three-phase current 28 V / 140 A

Deviating parameters of the power supply system must always be clarified with Liebherr-Hydraulikbagger GmbH.

Cooling system

Diesel engine	Water-cooled Compact cooling system consisting cooling unit for water, hydraulic oil and charge air with stepless thermostatically controlled fan
Electric motor	Air-cooled Cooling system for hydraulic oil with an infinitely variable, thermostatically controlled fan drive system

Hydraulic controls

Power distribution	Via control valves with integrated safety valves, simultaneous actuation of chassis and equipment. Swing drive in separate closed circuit
Servo circuit	
Equipment and swing	With electro-hydraulic pilot control and proportional joystick levers
Chassis mobile	Electro-proportional via foot pedal
Chassis crawler	With electric proportionally functioning foot pedals or adjusted with plugable levers
Additional functions	Via switch or electro-proportional foot pedals
Proportional control	Proportionally acting transmitters on the joysticks for additional hydraulic functions

Hydraulic system

Hydraulic pump	
For equipment and travel drive	2 Liebherr axial piston variable displacement pumps (double construction)
Max. flow	2 x 237 l/min.
Max. pressure	350 bar
For swing drive	Reversible axial piston variable displacement pump, closed-loop circuit
Max. flow	144 l/min.
Max. pressure	370 bar
Hydraulic pump regulation and control	2 circuit Liebherr-Synchron-Comfort-system (LSC) with electronic engine speed sensing regulation, pressure and flow compensation, automatic oil flow optimizer
Hydraulic tank	285 l
Hydraulic system	605 l
Filtration	1 main return filter with integrated partial micro filtration (5 µm)
MODE selection	Adjustment of engine and hydraulic performance via a mode pre-selector to match application, e.g. for especially economical and environmentally friendly operation or for maximum material handling and heavy-duty jobs
S (Sensitive)	Mode for precision work and lifting through very sensitive movements
E (Eco)	Mode for especially economical and environmentally friendly operation
P (Power)	Mode for high performance with low fuel consumption
P+ (Power-Plus)	Mode for highest performance and for very heavy duty applications, suitable for continuous operation
Engine speed and performance setting	Stepless alignment of engine output and hydraulic power via engine speed
Option	Tool Control: 20 pre-adjustable pump flows and pressures for add-on attachments

Swing drive

Drive	Liebherr axial piston motor in a closed system, Liebherr planetary reduction gear
Swing ring	Liebherr, sealed race ball bearing swing ring, internal teeth
Swing speed	0-6.5 RPM stepless
Swing torque	84 kNm
Holding brake	Wet multi-disc (spring applied, pressure released)
Option	Slewing gear brake Comfort



Cab

Cab	TOPS safety cab structure (tip-over protection) with individual windscreens or featuring a slide-in subpart under the ceiling, work headlights integrated in the ceiling, a door with a sliding window (can be opened on both sides), large stowing and depositing possibilities, shock-absorbing suspension, sound damping insulating, tinted laminated safety glass, separate shades for the sunroof window and windscreen
High Rise	Deviating from standard: safety cab structure with fixed built-in front and roof window made from impact-resistant laminated safety glass
Operator's seat Comfort	Air cushioned operator's seat with 3D-adjustable armrests, headrest, lap belt, seat heater, adjustable seat cushion inclination and length, lockable horizontal suspension, automatic weight adjustment, adjustable suspension stiffness, pneumatic lumbar vertebrae support and passive seat climatisation with active coal
Operator's seat Premium (Option)	In addition to operator's seat comfort: active electronic weight adjustment (automatic readjustment), pneumatic low frequency suspension and active seat climatisation with active coal and ventilator
Arm consoles	Joysticks with control consoles and swivel seat, folding left control console
Operation and displays	Large high-resolution operating unit, self-explanatory, colour display with touchscreen, video-compatible, numerous setting, control and monitoring options, e.g. air conditioning control, fuel consumption respectively energy consumption, machine and attachment parameters
Air-conditioning	
Diesel engine	Automatic air-conditioning, recirculated air function, fast de-icing and demisting at the press of a button, air vents can be operated via a menu; recirculated air and fresh air filters can be easily replaced and are accessible from the outside; heating-cooling unit, designed for extreme outside temperatures, sensors for solar radiation, inside and outside temperatures
Electric motor	In addition to diesel engine: stationary air conditioning function with external climate condenser - controlled by a weekly timer
Refrigerant	R134a
Global warming potential	1,430
Quantity at 25 °C*	1,400-1,600 g (Diesel) 1,500-1,800 g (Electric)
CO ₂ equivalent*	2.002-2.288 t (Diesel) 2.145-2.574 t (Electric)
Vibration emission**	
Hand / arm vibrations	< 2.5 m/s ²
Whole-body vibrations	< 0.5 m/s ²
Measuring inaccuracy	According with standard EN 12096:1997



Equipment

Type	Weight-optimised design for bulk and general cargo handling at optimal handling capacity. Complex and stable mountings of equipment and cylinders
Hydraulic cylinders	Liebherr cylinders with special sealing and guide system and, depending on cylinder type, shock absorption
Energy recovering cylinder	Liebherr gas cylinder with special sealing and control system
Bearings	Sealed, low maintenance

* depending on configuration

** for risk assessment according to 2002/44/EC see ISO/TR 25398:2006



Undercarriage

Mobile	
Versions	Standard, High Rise
Drive	Oversized two speed power shift transmission with additional creeper speed, Liebherr axial piston motor with functional brake valve on both sides
Travel speed	0- 3.0 km/h stepless
Joystick steering	(creeper speed + transmission stage 1) (Diesel) 0- 2.4 km/h stepless (creeper speed + transmission stage 1) (Electric) 0- 5.0 km/h stepless (transmission stage 1) 0-12.0 km/h stepless (creeper speed + transmission stage 2) 0-12.0 km/h stepless (transmission stage 2)
Travel speed	0- 3.0 km/h stepless
Wheel steering (Option)	(creeper speed + transmission stage 1) (Diesel) 0- 2.4 km/h stepless (creeper speed + transmission stage 1) (Electric) 0- 5.0 km/h stepless (transmission stage 1) 0-12.0 km/h stepless (creeper speed + transmission stage 2) 0-12.0 km/h stepless (transmission stage 2, only for High Rise) 0-20.0 km/h stepless (transmission stage 2, not for High Rise)
Driving operation	Automotive driving using accelerator pedal, cruise control function: storage of variable accelerator pedal positions
Axles	60 t / 70 t drive axles (LH 40 M / LH 50 M); manual or automatic hydraulically controlled front axle oscillation lock
Service brake	Two circuit travel brake system with accumulator; wet and backlash-free disc brake
Holding brake	Wet multi-disc (spring applied, pressure released)
Stabilization	4 point outriggers
Crawler	
Versions	SW, High Rise
Drive	Liebherr compact planetary reduction gear with Liebherr axial piston motor per side of undercarriage
Travel speed	
SW (LH 40)	0-3.9 km/h stepless 0-2.4 km/h stepless (creeper speed)
High Rise (LH 50)	0-3.7 km/h stepless 0-2.3 km/h stepless (creeper speed)
Brake	Functional brake valves on both sides
Holding brake	Wet multi-disc (spring applied, pressure released)
Track pads	Triple grouser, flat
Tracks	Sealed and greased



Complete machine

Lubrication	Liebherr central lubrication system for uppercarriage and equipment, automatically
Mobile (Option)	Liebherr central lubrication system for undercarriage, automatically
Steps system	Safe and durable access system with anti-slip steps; main components hot-galvanised
Noise emission	
ISO 6396	70 dB(A) = L _{pA} (inside cab)
2000/14/EC	103 dB(A) = L _{WA} (surround noise)

LH 40 M – Dimensions

Port

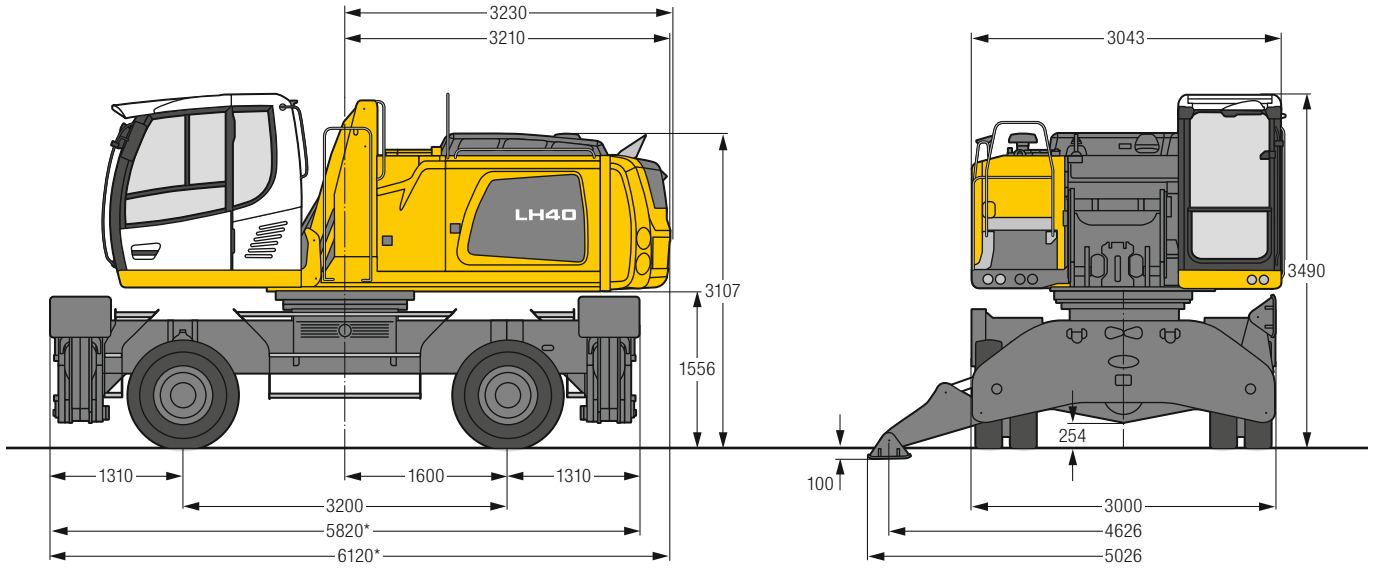

* For electric machines, the length of the machine is increased accordingly by the trailing cable / cable reel system. Detailed dimensions are available on request.

LH 40 M – Choice of cab elevation

Cab elevation LFC (rigid elevation)

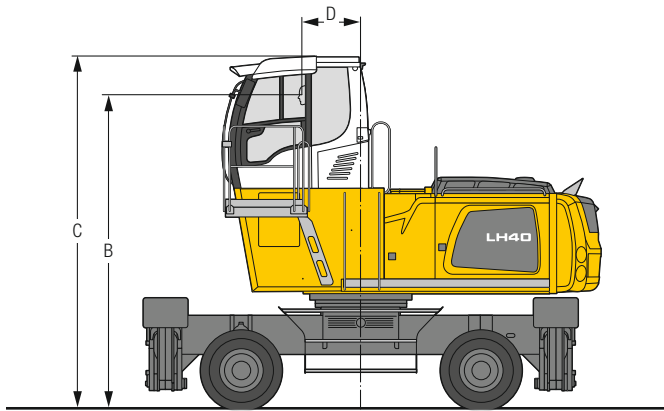

Increase type	LFC 120
Height	1,200 mm
B	4,216 mm
C	4,729 mm
D	770 mm

A rigid cab elevation has a fixed eye level height. For a lower transport height, the shell of the cab can be removed and replaced by a transport device. The dimension C is in this machine design for all rigid cab elevations 3,833 mm.

Tyres 12.00-20

Cab elevation LHC (hydraulic elevation)

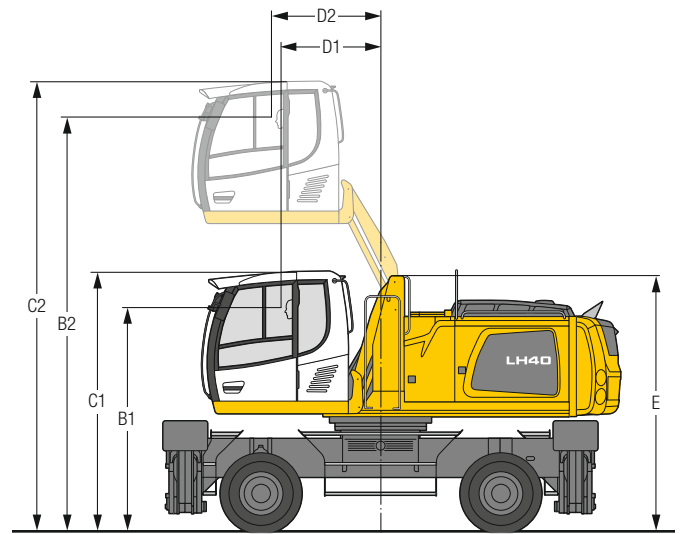

Increase type	LHC 255	LHC 340-35
B1	3,016 mm	3,367 mm
B2	5,563 mm	6,783 mm
C1	3,490 mm	3,880 mm
C2	6,037 mm	7,296 mm
D1	1,325 mm	2,439 mm
D2	1,450 mm	2,439 mm
E	3,431 mm	3,821 mm

The hydraulically adjustable cab allows the driver, that he can choose his field of view freely and at any time within the stroke.

LH 40 C – Dimensions

Port

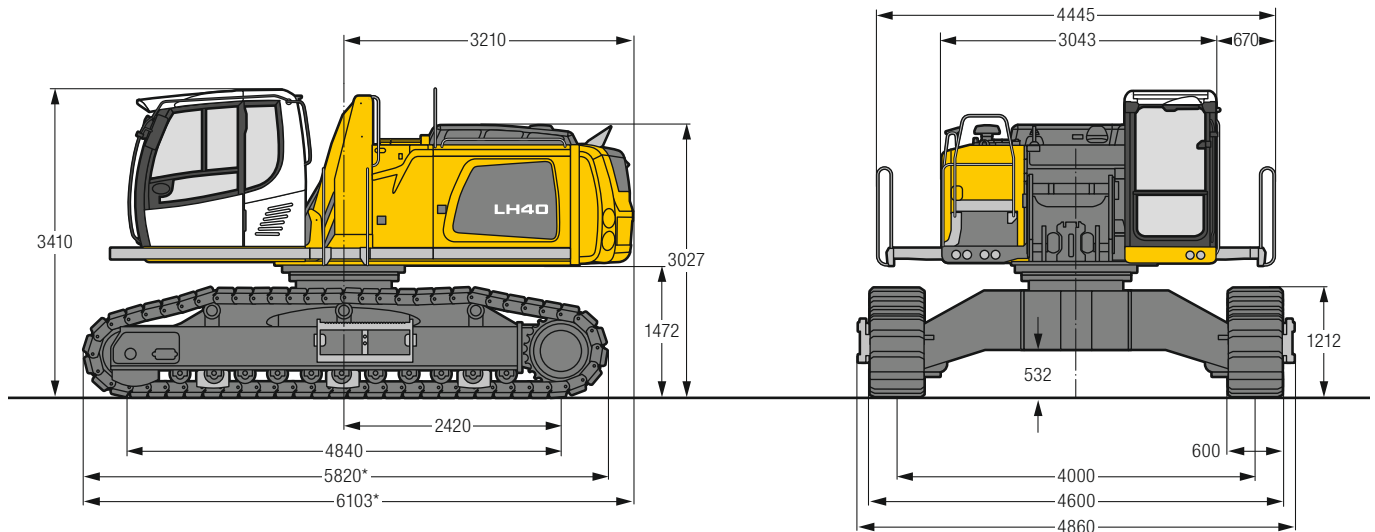

* For electric machines, the length of the machine is increased accordingly by the trailing cable / cable reel system. Detailed dimensions are available on request.

LH 40 C – Choice of cab elevation

Cab elevation LFC (rigid elevation)

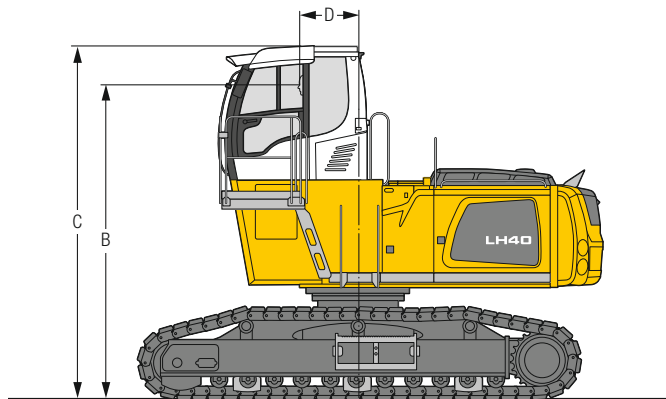

Increase type	LFC 120
Height	1,200 mm
B	4,136 mm
C	4,650 mm
D	770 mm

A rigid cab elevation has a fixed eye level height. For a lower transport height, the shell of the cab can be removed and replaced by a transport device. The dimension C is in this machine design for all rigid cab elevations 3,754 mm.

Cab elevation LHC (hydraulic elevation)

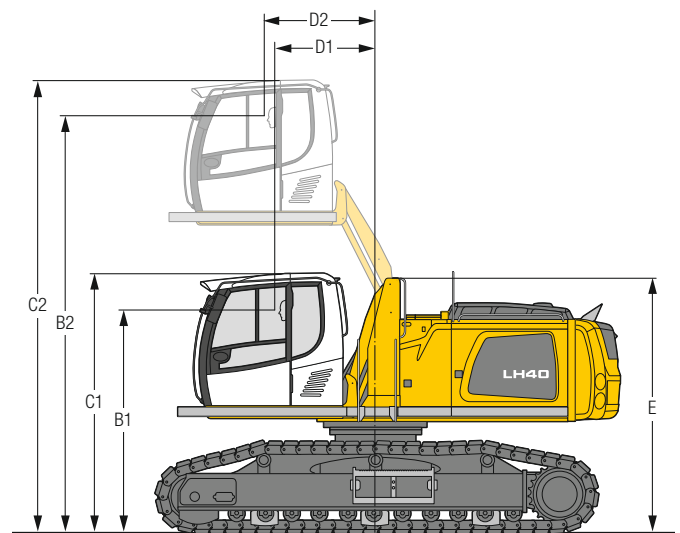

Increase type	LHC 255	LHC 340-35
B1	2,936 mm	3,287 mm
B2	5,483 mm	6,703 mm
C1	3,410 mm	3,801 mm
C2	5,957 mm	7,217 mm
D1	1,325 mm	2,439 mm
D2	1,450 mm	2,439 mm
E	3,351 mm	3,741 mm

The hydraulically adjustable cab allows the driver, that he can choose his field of view freely and at any time within the stroke.

LH 50 M HR – Dimensions

Port

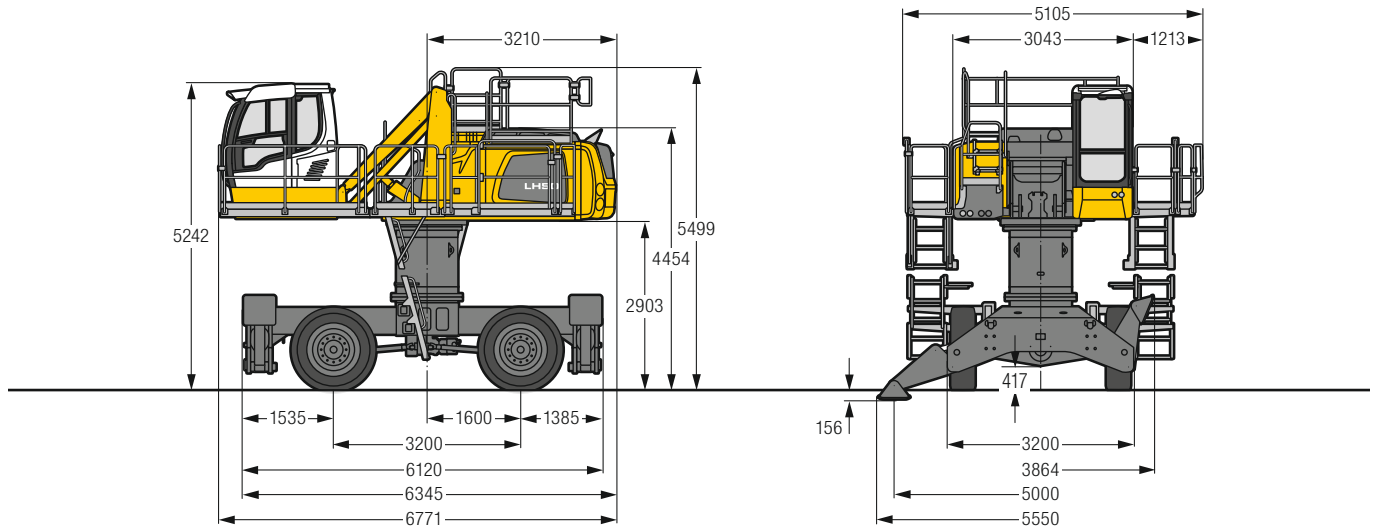

LH 50 M HR – Cab elevation

Cab elevation LHC (hydraulic elevation)

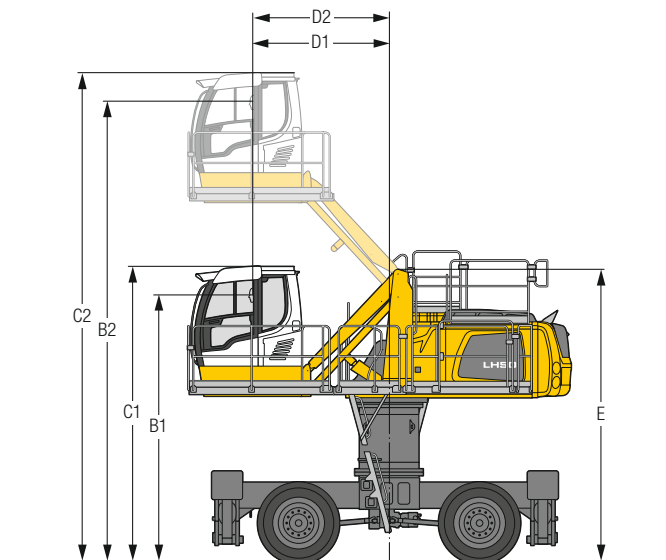

Increase type	LHC 340-35
B1	4,720 mm
B2	8,135 mm
C1	5,242 mm
C2	8,657 mm
D1	2,411 mm
D2	2,413 mm
E	5,168 mm

The hydraulically adjustable cab allows the driver, that he can choose his field of view freely and at any time within the stroke.

Tyres 16.00-25

LH 50 C HR – Dimensions

Port

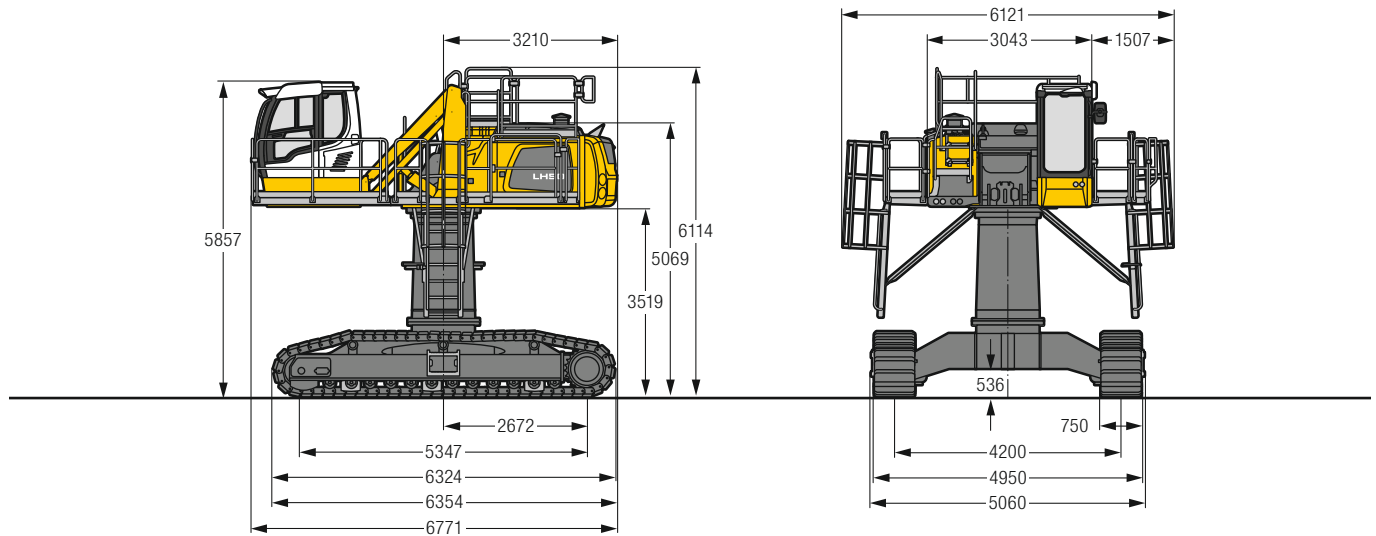

LH 50 C HR – Cab elevation

Cab elevation LHC (hydraulic elevation)

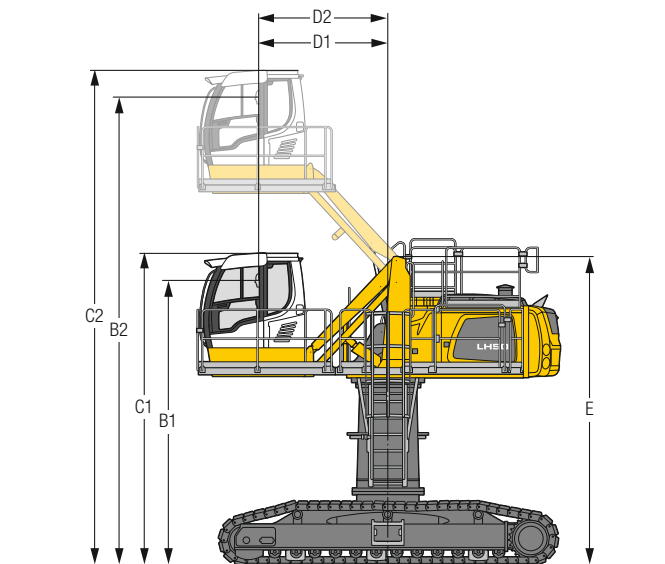

Increase type	LHC 340-35
B1	5,336 mm
B2	8,750 mm
C1	5,857 mm
C2	9,272 mm
D1	2,411 mm
D2	2,413 mm
E	5,784 mm

The hydraulically adjustable cab allows the driver, that he can choose his field of view freely and at any time within the stroke.

Kinematic variant 2A

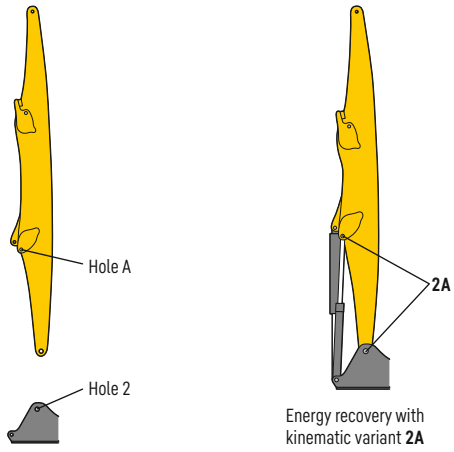

Kinematic variant 2D / 2C

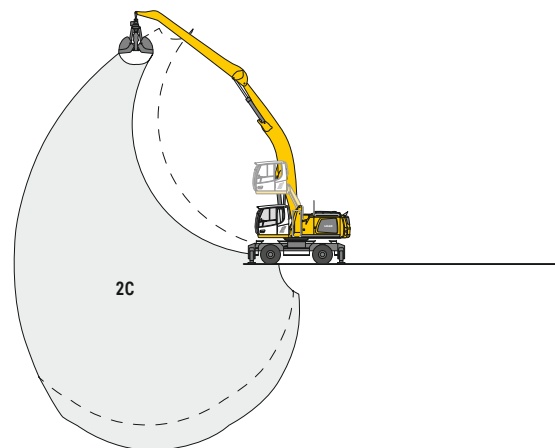
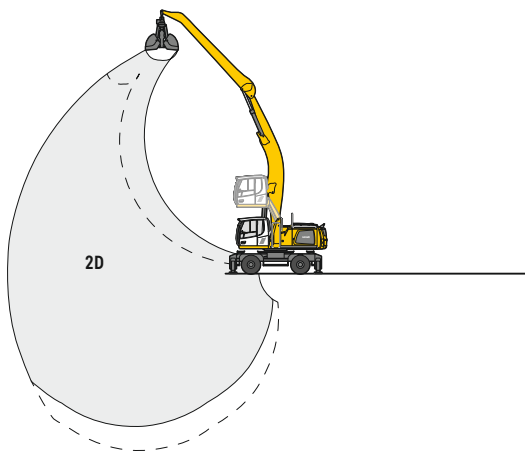
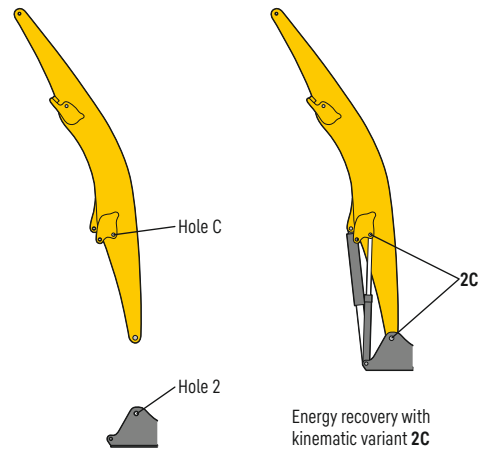
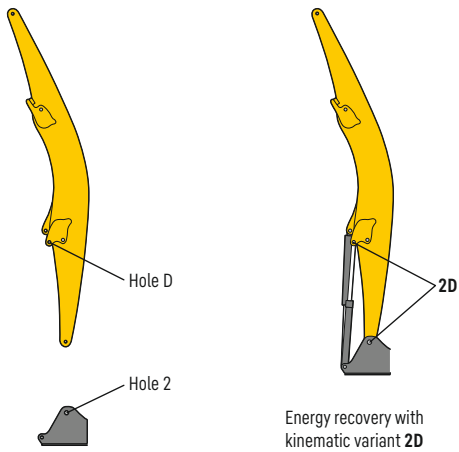

Altered range curve with additional reach depth, e.g. for unloading from ships

LH 40 M – Equipment GG16

Port – Kinematic 2A

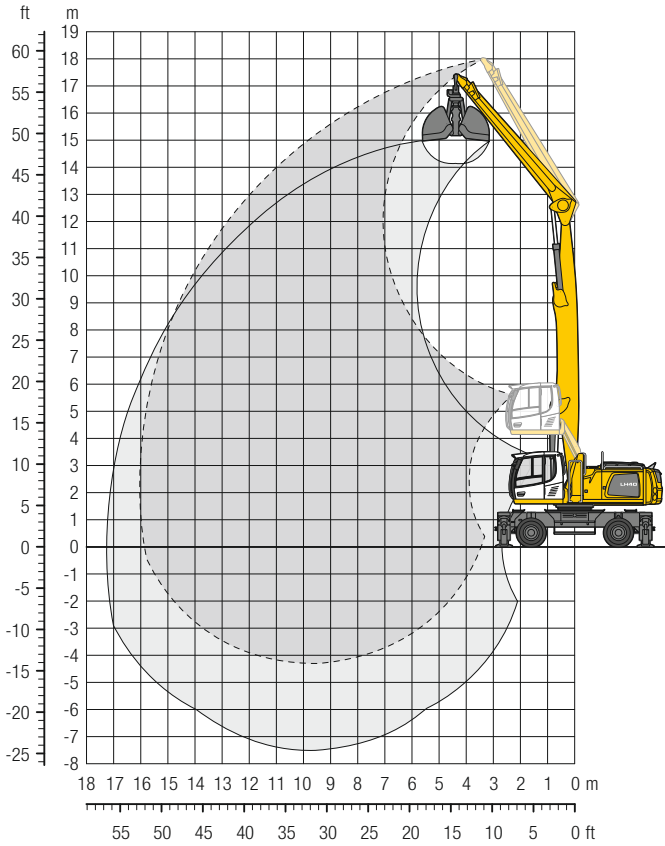

Dimensions

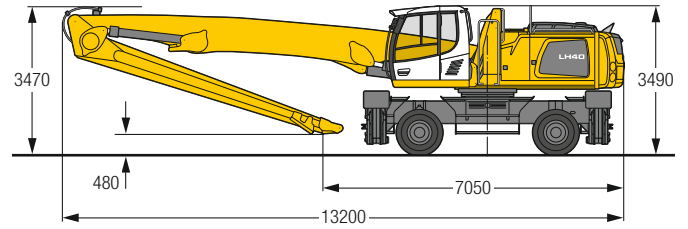

Operating weight

The operating weight includes the basic machine with 4 point outriggers, hydr. cab elevation, 8 solid tyres plus intermediate rings, straight boom 9.60m, straight stick 6.70m and grab for loose material GMZ 40 / 2.00 m³.

Weight 44,400 kg

m	Undercarriage	4.5m		6.0m		7.5m		9.0m		10.5m		12.0m		13.5m		15.0m		16.5m		18.0m		Max. reach		m
		Can be slewed through 360°	In longitudinal position of undercarriage	Can be slewed through 360°	In longitudinal position of undercarriage	Can be slewed through 360°	In longitudinal position of undercarriage	Can be slewed through 360°	In longitudinal position of undercarriage	Can be slewed through 360°	In longitudinal position of undercarriage	Can be slewed through 360°	In longitudinal position of undercarriage	Can be slewed through 360°	In longitudinal position of undercarriage	Can be slewed through 360°	In longitudinal position of undercarriage	Can be slewed through 360°	In longitudinal position of undercarriage	Can be slewed through 360°	In longitudinal position of undercarriage	Can be slewed through 360°	In longitudinal position of undercarriage	
16.5	4 pt. outriggers down			9.8*	9.8*																	7.5*	7.5*	7.4
15.0	4 pt. outriggers down					9.6*	9.6*	7.9*	7.9*													6.3*	6.3*	9.8
13.5	4 pt. outriggers down					9.4*	9.4*	8.3*	8.3*	7.5*	7.5*											5.7*	5.7*	11.5
12.0	4 pt. outriggers down					9.3*	9.3*	8.2*	8.2*	7.4*	7.4*	6.8*	6.8*									5.3*	5.3*	12.8
10.5	4 pt. outriggers down					9.4*	9.4*	8.3*	8.3*	7.4*	7.4*	6.7*	6.7*	6.0*	6.0*							5.1*	5.1*	13.8
9.0	4 pt. outriggers down					9.6*	9.6*	8.4*	8.4*	7.5*	7.5*	6.8*	6.8*	6.2*	6.2*							4.9*	4.9*	14.6
7.5	4 pt. outriggers down			11.9*	11.9*	10.0*	10.0*	8.6*	8.6*	7.6*	7.6*	6.8*	6.8*	6.2*	6.2*	5.4	5.5*					4.9*	4.9*	15.2
6.0	4 pt. outriggers down	12.8*	12.8*	12.7*	12.7*	10.5*	10.5*	8.9*	8.9*	7.8*	7.8*	6.9*	6.9*	6.2*	6.2*	5.4	5.5*					4.9*	4.9*	15.6
4.5	4 pt. outriggers down	18.3*	18.3*	13.7*	13.7*	11.0*	11.0*	9.2*	9.2*	8.0*	8.0*	7.0*	7.0*	6.2*	6.2*	5.3	5.5*					4.8	4.9*	15.9
3.0	4 pt. outriggers down	5.2*	5.2*	14.5*	14.5*	11.5*	11.5*	9.5*	9.5*	8.1*	8.1*	7.1*	7.1*	6.2	6.2*	5.2	5.4*					4.7*	4.7*	16.0
1.5	4 pt. outriggers down	2.6*	2.6*	11.5*	11.5*	11.7*	11.7*	9.6*	9.6*	8.2*	8.2*	7.0*	7.0*	6.0	6.1*	5.2	5.2*					4.3*	4.3*	16.0
0	4 pt. outriggers down	2.9*	2.9*	8.1*	8.1*	11.6*	11.6*	9.5*	9.5*	8.0*	8.0*	6.9*	6.9*	5.9*	5.9*	4.8*	4.8*					3.9*	3.9*	15.8
-1.5	4 pt. outriggers down	3.9*	3.9*	7.8*	7.8*	10.9*	10.9*	9.1*	9.1*	7.7*	7.7*	6.5*	6.5*	5.4*	5.4*	4.1*	4.1*					3.9*	3.9*	15.2
-3.0	4 pt. outriggers down			8.4*	8.4*	9.7*	9.7*	8.2*	8.2*	6.9*	6.9*	5.8*	5.8*	4.6*	4.6*							4.4*	4.4*	13.7

Height Can be slewed through 360° In longitudinal position of undercarriage Max. reach * Limited by hydr. capacity

The lift capacities on the stick end without attachment are stated in metric tons (t) and are valid on a firm, level supporting surface with blocked oscillating axle. These capacities can be slewed through 360° with the undercarriage in the transverse position. Capacities in the longitudinal position of the undercarriage (±15°) are specified over the rigid axle with the stabilizers down. Indicated loads based on the ISO 10567 standard and do not exceed 75% of tipping or 87% of hydraulic capacity. The lift capacity values indicated are attained at the corresponding operating temperature. This operating temperature is ensured by continuous movement of the boom. Weights of fitted attachments (grabs, load hooks, etc.) and load accommodation attachment are to be deducted from the lift capacity values. The lift capacity of the unit is limited by its stability, the lifting capability of the hydraulic elements, or the maximum permissible lifting capacity of the load hook. In accordance with the harmonised European Standard EN 474-5, hydraulic excavators used for lifting operations must be equipped with pipe fracture safety valves, an overload warning device, a load hook and a lift capacity chart.

LH 40 M – Equipment GG18

Port – Kinematic 2A

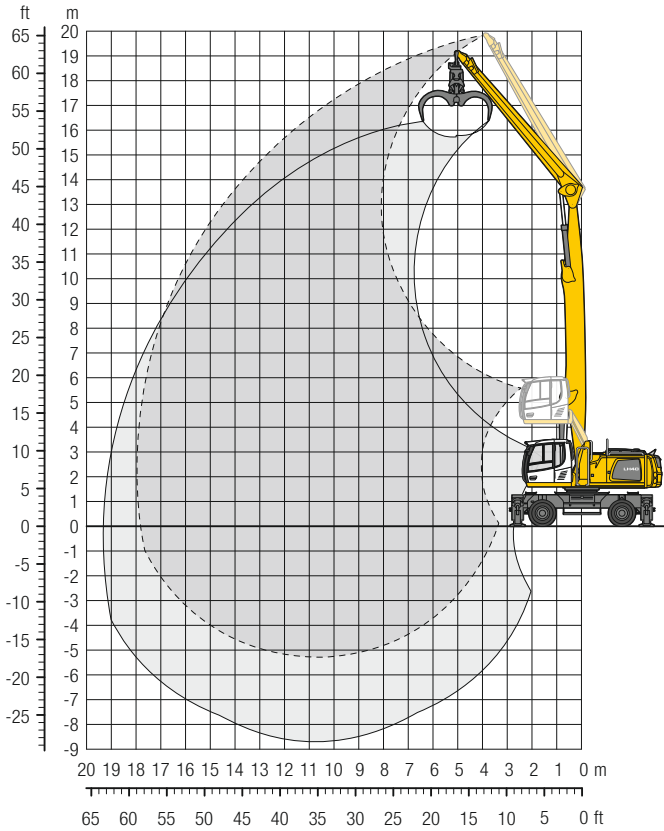

Dimensions

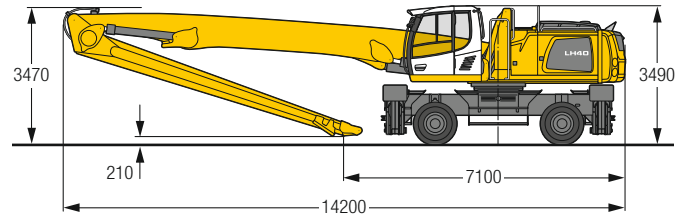

Operating weight

The operating weight includes the basic machine with 4 point outriggers, hydr. cab elevation, 8 solid tyres plus intermediate rings, straight boom 10.60 m, straight stick 7.70 m and wood grab GMH 40 / 1.30 m².

Weight	44,600 kg
--------	-----------

m	Undercarriage	4.5 m		6.0 m		7.5 m		9.0 m		10.5 m		12.0 m		13.5 m		15.0 m		16.5 m		18.0 m		m		
		360°	15°	360°	15°	360°	15°	360°	15°	360°	15°	360°	15°	360°	15°	360°	15°	360°	15°	360°	15°	360°	15°	
19.5	4 pt. outriggers down	9.4*	9.4*																			8.5*	8.5*	5.2
18.0	4 pt. outriggers down					7.9*	7.9*															6.2*	6.2*	8.7
16.5	4 pt. outriggers down					8.7*	8.7*	7.8*	7.8*	6.3*	6.3*											5.4*	5.4*	11.0
15.0	4 pt. outriggers down							7.8*	7.8*	6.9*	6.9*	6.2*	6.2*									4.9*	4.9*	12.7
13.5	4 pt. outriggers down							7.7*	7.7*	6.9*	6.9*	6.2*	6.2*	5.7*	5.7*							4.6*	4.6*	14.1
12.0	4 pt. outriggers down							7.7*	7.7*	6.8*	6.8*	6.2*	6.2*	5.6*	5.6*	4.7*	4.7*					4.4*	4.4*	15.1
10.5	4 pt. outriggers down							7.8*	7.8*	6.9*	6.9*	6.2*	6.2*	5.6*	5.6*	5.1*	5.1*					4.2*	4.2*	16.0
9.0	4 pt. outriggers down					9.2*	9.2*	7.9*	7.9*	7.0*	7.0*	6.3*	6.3*	5.7*	5.7*	5.1*	5.1*	4.6	4.7*			4.1*	4.1*	16.7
7.5	4 pt. outriggers down			10.0*	10.0*	9.5*	9.5*	8.2*	8.2*	7.1*	7.1*	6.3*	6.3*	5.7*	5.7*	5.2*	5.2*	4.6	4.6*			4.1*	4.1*	17.2
6.0	4 pt. outriggers down	10.3*	10.3*	12.3*	12.3*	10.0*	10.0*	8.4*	8.4*	7.3*	7.3*	6.4*	6.4*	5.8*	5.8*	5.2*	5.2*	4.5	4.6*			4.0	4.1*	17.6
4.5	4 pt. outriggers down	17.6*	17.6*	13.1*	13.1*	10.4*	10.4*	8.7*	8.7*	7.5*	7.5*	6.5*	6.5*	5.8*	5.8*	5.2*	5.2*	4.4	4.6*			3.9	4.0*	17.8
3.0	4 pt. outriggers down	3.3*	3.3*	13.7*	13.7*	10.8*	10.8*	8.9*	8.9*	7.6*	7.6*	6.6*	6.6*	5.8*	5.8*	5.1	5.1*	4.4	4.5*			3.7*	3.7*	18.0
1.5	4 pt. outriggers down	1.6*	1.6*	7.5*	7.5*	11.0*	11.0*	9.1*	9.1*	7.7*	7.7*	6.6*	6.6*	5.8*	5.8*	5.0	5.1*	4.3	4.4*			3.5*	3.5*	17.9
0	4 pt. outriggers down	1.9*	1.9*	5.5*	5.5*	10.9*	10.9*	9.0*	9.0*	7.6*	7.6*	6.5*	6.5*	5.6*	5.6*	4.9	4.9*	4.1*	4.1*			3.2*	3.2*	17.8
-1.5	4 pt. outriggers down	2.6*	2.6*	5.4*	5.4*	10.3*	10.3*	8.6*	8.6*	7.3*	7.3*	6.3*	6.3*	5.4*	5.4*	4.6*	4.6*	3.7*	3.7*			3.0*	3.0*	17.4
-3.0	4 pt. outriggers down			5.9*	5.9*	9.4*	9.4*	8.0*	8.0*	6.8*	6.8*	5.8*	5.8*	4.9*	4.9*	4.1*	4.1*					3.2*	3.2*	16.2
-4.5	4 pt. outriggers down					7.9*	7.9*	6.9*	6.9*	6.0*	6.0*	5.1*	5.1*	4.2*	4.2*							3.8*	3.8*	14.2

Height Can be slewed through 360° In longitudinal position of undercarriage Max. reach * Limited by hydr. capacity

The lift capacities on the stick end without attachment are stated in metric tons (t) and are valid on a firm, level supporting surface with blocked oscillating axle. These capacities can be slewed through 360° with the undercarriage in the transverse position. Capacities in the longitudinal position of the undercarriage (±15°) are specified over the rigid axle with the stabilizers down. Indicated loads based on the ISO 10567 standard and do not exceed 75% of tipping or 87% of hydraulic capacity. The lift capacity values indicated are attained at the corresponding operating temperature. This operating temperature is ensured by continuous movement of the boom. Weights of fitted attachments (grabs, load hooks, etc.) and load accommodation attachment are to be deducted from the lift capacity values. The lift capacity of the unit is limited by its stability, the lifting capability of the hydraulic elements, or the maximum permissible lifting capacity of the load hook.

In accordance with the harmonised European Standard EN 474-5, hydraulic excavators used for lifting operations must be equipped with pipe fracture safety valves, an overload warning device, a load hook and a lift capacity chart.

LH 40 M – Equipment AG17

Port – Kinematic 2D

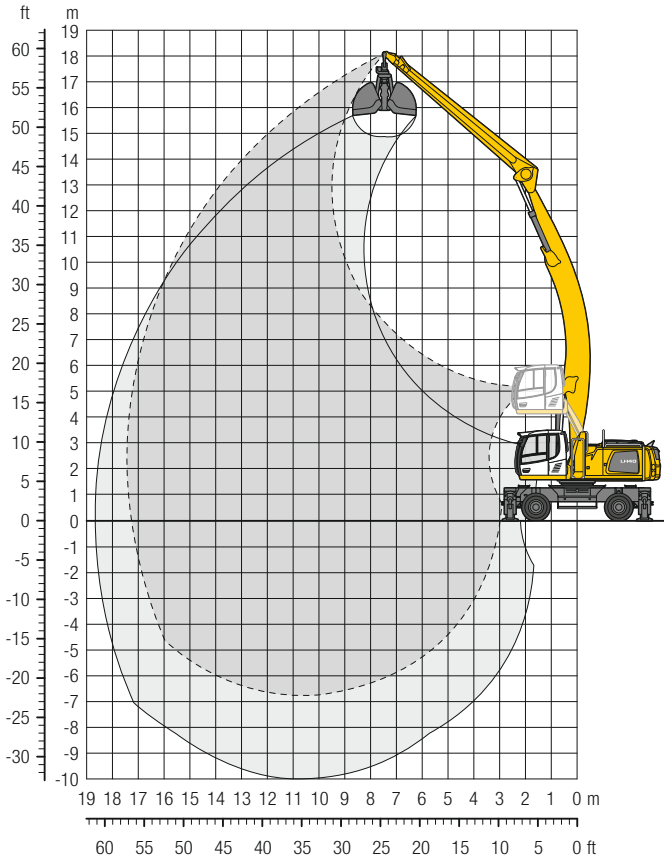

Dimensions

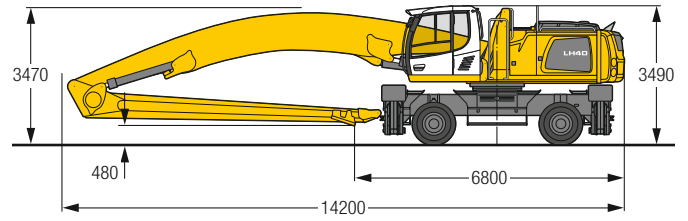

Operating weight

The operating weight includes the basic machine with 4 point outriggers, hydr. cab elevation, 8 solid tyres plus intermediate rings, angled boom 10.60 m, straight stick 7.70 m and grab for loose material GMZ 40 / 2.00 m³.

Weight 45,300 kg

m	Undercarriage	4.5 m		6.0 m		7.5 m		9.0 m		10.5 m		12.0 m		13.5 m		15.0 m		16.5 m		18.0 m		m			
		☞	☞	☞	☞	☞	☞	☞	☞	☞	☞	☞	☞	☞	☞	☞	☞	☞	☞	☞	☞	☞	☞		
18.0	4 pt. outriggers down																					5.8*	5.8*	7.6	
16.5	4 pt. outriggers down							6.3*	6.3*														5.0*	5.0*	10.1
15.0	4 pt. outriggers down									6.1*	6.1*												4.6*	4.6*	12.0
13.5	4 pt. outriggers down									6.0*	6.0*	5.5*	5.5*										4.4*	4.4*	13.4
12.0	4 pt. outriggers down									6.0*	6.0*	5.5*	5.5*	5.1*	5.1*								4.2*	4.2*	14.5
10.5	4 pt. outriggers down									6.1*	6.1*	5.5*	5.5*	5.1*	5.1*	4.7*	4.7*						4.1*	4.1*	15.4
9.0	4 pt. outriggers down							6.9*	6.9*	6.2*	6.2*	5.6*	5.6*	5.1*	5.1*	4.7*	4.7*						4.1*	4.1*	16.1
7.5	4 pt. outriggers down					8.3*	8.3*	7.2*	7.2*	6.4*	6.4*	5.7*	5.7*	5.2*	5.2*	4.8*	4.8*	4.4*	4.4*				4.1*	4.1*	16.7
6.0	4 pt. outriggers down			10.8*	10.8*	8.8*	8.8*	7.5*	7.5*	6.6*	6.6*	5.9*	5.9*	5.3*	5.3*	4.8*	4.8*	4.4*	4.4*				4.2*	4.2*	17.1
4.5	4 pt. outriggers down	15.7*	15.7*	11.7*	11.7*	9.4*	9.4*	7.9*	7.9*	6.8*	6.8*	6.0*	6.0*	5.4*	5.4*	4.9*	4.9*	4.4*	4.4*				4.1	4.2*	17.3
3.0	4 pt. outriggers down	6.9*	6.9*	12.6*	12.6*	9.9*	9.9*	8.2*	8.2*	7.0*	7.0*	6.2*	6.2*	5.5*	5.5*	4.9*	4.9*	4.4	4.4*				4.0	4.1*	17.4
1.5	4 pt. outriggers down	3.7*	3.7*	10.6*	10.6*	10.3*	10.3*	8.5*	8.5*	7.2*	7.2*	6.3*	6.3*	5.5*	5.5*	4.9*	4.9*	4.3	4.4*				3.9	4.1*	17.4
0	4 pt. outriggers down	3.5*	3.5*	7.5*	7.5*	10.5*	10.5*	8.7*	8.7*	7.3*	7.3*	6.3*	6.3*	5.6*	5.6*	4.9	4.9*	4.2	4.3*				3.9	4.0*	17.3
-1.5	4 pt. outriggers down	4.0*	4.0*	6.8*	6.8*	10.5*	10.5*	8.6*	8.6*	7.3*	7.3*	6.3*	6.3*	5.5*	5.5*	4.8	4.8*	4.1*	4.1*				3.8*	3.8*	17.0
-3.0	4 pt. outriggers down	4.7*	4.7*	7.0*	7.0*	10.1*	10.1*	8.4*	8.4*	7.1*	7.1*	6.1*	6.1*	5.3*	5.3*	4.5*	4.5*	3.7*	3.7*				3.7*	3.7*	16.6
-4.5	4 pt. outriggers down			7.5*	7.5*	9.3*	9.3*	7.9*	7.9*	6.7*	6.7*	5.7*	5.7*	4.9*	4.9*	4.1*	4.1*						3.4*	3.4*	16.0
-6.0	4 pt. outriggers down					8.1*	8.1*	7.0*	7.0*	6.0*	6.0*	5.1*	5.1*	4.3*	4.3*								3.9*	3.9*	14.0

☞ Height ☞ Can be slewed through 360° ☞ In longitudinal position of undercarriage ☞ Max. reach * Limited by hydr. capacity

The lift capacities on the stick end without attachment are stated in metric tons (t) and are valid on a firm, level supporting surface with blocked oscillating axle. These capacities can be slewed through 360° with the undercarriage in the transverse position. Capacities in the longitudinal position of the undercarriage (±15°) are specified over the rigid axle with the stabilizers down. Indicated loads based on the ISO 10567 standard and do not exceed 75% of tipping or 87% of hydraulic capacity. The lift capacity values indicated are attained at the corresponding operating temperature. This operating temperature is ensured by continuous movement of the boom. Weights of fitted attachments (grabs, load hooks, etc.) and load accommodation attachment are to be deducted from the lift capacity values. The lift capacity of the unit is limited by its stability, the lifting capability of the hydraulic elements, or the maximum permissible lifting capacity of the load hook. In accordance with the harmonised European Standard EN 474-5, hydraulic excavators used for lifting operations must be equipped with pipe fracture safety valves, an overload warning device, a load hook and a lift capacity chart.

LH 40 C SW – Equipment GG18

Port – Kinematic 2A

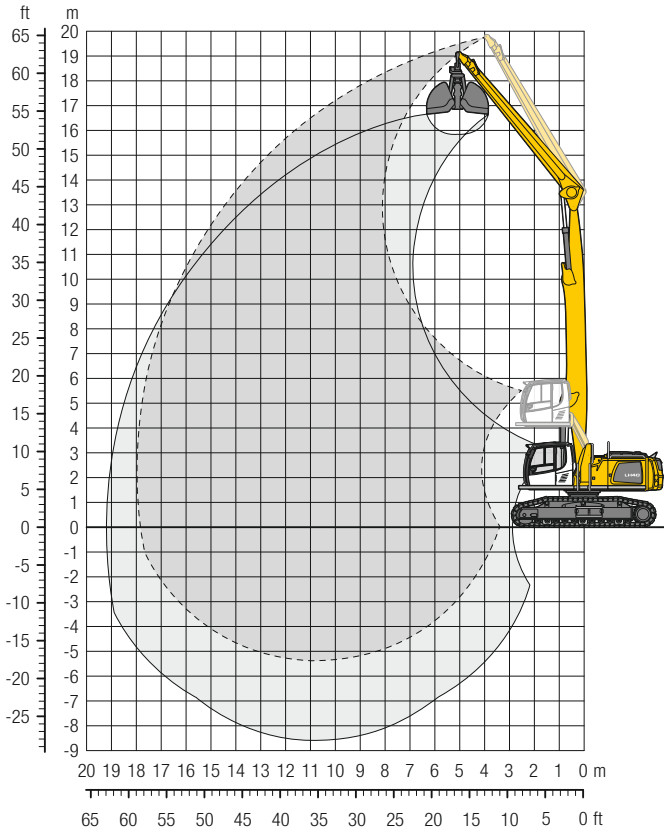

Dimensions

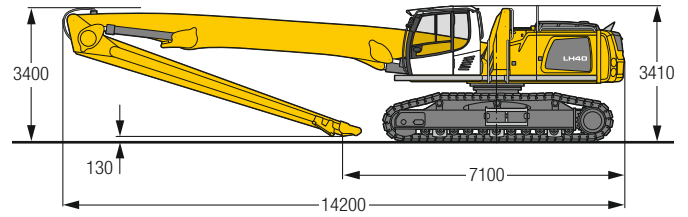

Operating weight and ground pressure

The operating weight includes the basic machine with hydr. cab elevation, straight boom 10.60 m, straight stick 7.70 m and grab for loose material GMZ 40 / 2.00 m³.

Weight	48,700 kg
Pad width	600 mm
Ground pressure	on request

m	Undercarriage	4.5m		6.0m		7.5m		9.0m		10.5m		12.0m		13.5m		15.0m		16.5m		18.0m		Max. reach		m
		Can be slewed through 360°	In longitudinal position of undercarriage	Can be slewed through 360°	In longitudinal position of undercarriage	Can be slewed through 360°	In longitudinal position of undercarriage	Can be slewed through 360°	In longitudinal position of undercarriage	Can be slewed through 360°	In longitudinal position of undercarriage	Can be slewed through 360°	In longitudinal position of undercarriage	Can be slewed through 360°	In longitudinal position of undercarriage	Can be slewed through 360°	In longitudinal position of undercarriage	Can be slewed through 360°	In longitudinal position of undercarriage	Can be slewed through 360°	In longitudinal position of undercarriage	Can be slewed through 360°	In longitudinal position of undercarriage	
19.5	SW	9.3*	9.3*																			8.7*	8.7*	5.0
18.0	SW					7.8*	7.8*															6.3*	6.3*	8.6
16.5	SW					8.7*	8.7*	7.8*	7.8*	6.2*	6.2*											5.4*	5.4*	11.0
15.0	SW							7.8*	7.8*	6.9*	6.9*	6.1*	6.1*									4.9*	4.9*	12.7
13.5	SW							7.7*	7.7*	6.9*	6.9*	6.2*	6.2*	5.6*	5.6*							4.6*	4.6*	14.0
12.0	SW							7.7*	7.7*	6.8*	6.8*	6.2*	6.2*	5.6*	5.6*	4.7*	4.7*					4.4*	4.4*	15.1
10.5	SW							7.8*	7.8*	6.9*	6.9*	6.2*	6.2*	5.6*	5.6*	5.1*	5.1*					4.2*	4.2*	16.0
9.0	SW							9.2*	9.2*	7.9*	7.9*	7.0*	7.0*	6.3*	6.3*	5.7*	5.7*	5.1*	5.1*	4.4	4.6*	4.1*	4.1*	16.7
7.5	SW			9.9*	9.9*	9.5*	9.5*	8.2*	8.2*	7.1*	7.1*	6.3*	6.3*	5.7*	5.7*	5.2*	5.2*	4.4	4.6*			4.1	4.1*	17.2
6.0	SW	10.1*	10.1*	12.2*	12.2*	10.0*	10.0*	8.4*	8.4*	7.3*	7.3*	6.4*	6.4*	5.8*	5.8*	5.2	5.2*	4.4	4.6*			3.9	4.1*	17.6
4.5	SW	17.5*	17.5*	13.0*	13.0*	10.4*	10.4*	8.7*	8.7*	7.5*	7.5*	6.5*	6.5*	5.8*	5.8*	5.1	5.2*	4.3	4.6*			3.8	4.0*	17.8
3.0	SW	3.5*	3.5*	13.7*	13.7*	10.8*	10.8*	8.9*	8.9*	7.6*	7.6*	6.6*	6.6*	5.8	5.8*	4.9	5.1*	4.2	4.5*			3.7	3.7*	18.0
1.5	SW	1.7*	1.7*	7.6*	7.6*	11.0*	11.0*	9.1*	9.1*	7.7*	7.7*	6.6*	6.6*	5.6	5.8*	4.8	5.1*	4.2	4.4*			3.5*	3.5*	17.9
0	SW	1.9*	1.9*	5.5*	5.5*	10.9*	10.9*	9.0*	9.0*	7.6*	7.6*	6.5	6.5*	5.5	5.7*	4.7	4.9*	4.1	4.1*			3.2*	3.2*	17.8
-1.5	SW	2.6*	2.6*	5.4*	5.4*	10.4*	10.4*	8.7*	8.7*	7.3*	7.3*	6.3*	6.3*	5.3	5.4*	4.6*	4.6*	3.7*	3.7*			3.0*	3.0*	17.4
-3.0	SW			5.9*	5.9*	9.4*	9.4*	8.0*	8.0*	6.8*	6.8*	5.8*	5.8*	4.9*	4.9*	4.1*	4.1*					3.2*	3.2*	16.3
-4.5	SW					8.0*	8.0*	7.0*	7.0*	6.0*	6.0*	5.1*	5.1*	4.2*	4.2*							3.8*	3.8*	14.3

Height Can be slewed through 360° In longitudinal position of undercarriage Max. reach * Limited by hydr. capacity

The lift capacities on the stick end without attachment are stated in metric tons (t) and can be slewed through 360° on a firm, level supporting surface. Capacities are valid for 600 mm wide flat pads. Indicated loads based on the ISO 10567 standard and do not exceed 75% of tipping or 87% of hydraulic capacity. The lift capacity values indicated are attained at the corresponding operating temperature. This operating temperature is ensured by continuous movement of the boom. Weights of fitted attachments (grabs, load hooks, etc.) and load accommodation attachment are to be deducted from the lift capacity values. The lift capacity of the unit is limited by its stability, the lifting capability of the hydraulic elements, or the maximum permissible lifting capacity of the load hook. In accordance with the harmonised European Standard EN 474-5, hydraulic excavators used for lifting operations must be equipped with pipe fracture safety valves, an overload warning device, a load hook and a lift capacity chart.

LH 40 C SW – Equipment AG16

Port – Kinematic 2D

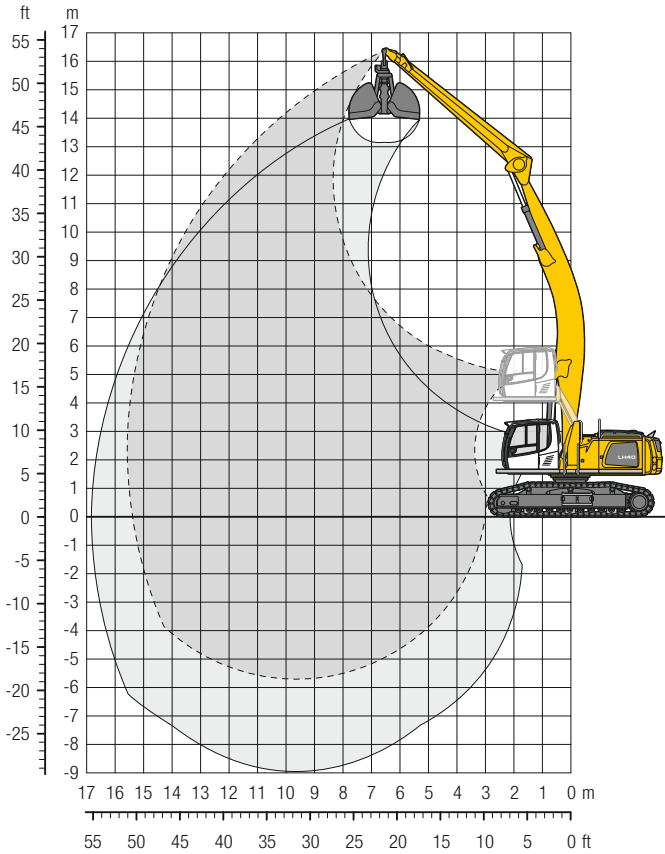

Dimensions

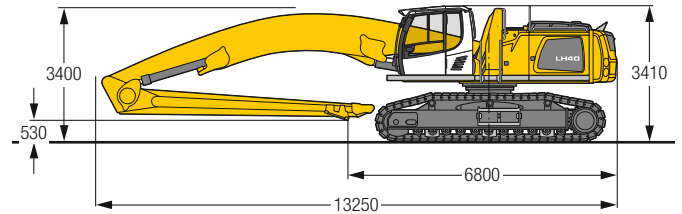

Operating weight and ground pressure

The operating weight includes the basic machine with hydr. cab elevation, angled boom 9.60 m, straight stick 6.70 m and grab for loose material GMZ 40 / 2.00 m³.

Weight	48,500 kg
Pad width	600 mm
Ground pressure	on request

m	Undercarriage	4.5m		6.0m		7.5m		9.0m		10.5m		12.0m		13.5m		15.0m		16.5m		18.0m		m	
		↙	↕	↙	↕	↙	↕	↙	↕	↙	↕	↙	↕	↙	↕	↙	↕	↙	↕	↙	↕	↙	↕
19.5	SW																						
18.0	SW																						
16.5	SW																						
15.0	SW																						
13.5	SW							7.3*	7.3*	5.9*	5.9*									5.9*	5.9*	8.9	
12.0	SW							7.2*	7.2*	6.6*	6.6*	5.5*	5.5*							5.1*	5.1*	12.2	
10.5	SW							7.3*	7.3*	6.6*	6.6*	6.1*	6.1*							4.9*	4.9*	13.2	
9.0	SW							7.4*	7.4*	6.7*	6.7*	6.1*	6.1*							4.9*	4.9*	14.0	
7.5	SW					8.8*	8.8*	7.7*	7.7*	6.9*	6.9*	6.2*	6.2*	5.7*	5.7*					4.9*	4.9*	14.7	
6.0	SW			11.2*	11.2*	9.3*	9.3*	8.0*	8.0*	7.1*	7.1*	6.4*	6.4*	5.8*	5.8*	5.3	5.3*			4.9*	4.9*	15.1	
4.5	SW	16.3*	16.3*	12.3*	12.3*	9.9*	9.9*	8.4*	8.4*	7.3*	7.3*	6.5*	6.5*	5.9*	5.9*	5.2	5.3*			5.0	5.0*	15.4	
3.0	SW	10.0*	10.0*	13.4*	13.4*	10.6*	10.6*	8.8*	8.8*	7.6*	7.6*	6.7*	6.7*	6.0*	6.0*	5.1	5.3*			4.8	5.1*	15.6	
1.5	SW	5.0*	5.0*	14.1*	14.1*	11.1*	11.1*	9.1*	9.1*	7.8*	7.8*	6.8*	6.8*	5.9	6.0*	5.0	5.3*			4.8	5.0*	15.5	
0	SW	4.7*	4.7*	10.4*	10.4*	11.3*	11.3*	9.3*	9.3*	7.9*	7.9*	6.8	6.8*	5.8	6.0*	5.0	5.1*			4.8	4.9*	15.4	
-1.5	SW	5.3*	5.3*	9.4*	9.4*	11.2*	11.2*	9.3*	9.3*	7.8*	7.8*	6.7	6.7*	5.7	5.8*	4.8*	4.8*			4.7*	4.7*	15.1	
-3.0	SW	6.1*	6.1*	9.5*	9.5*	10.7*	10.7*	8.9*	8.9*	7.5*	7.5*	6.4*	6.4*	5.4*	5.4*					4.5*	4.5*	14.6	
-4.5	SW			10.1*	10.1*	9.7*	9.7*	8.2*	8.2*	6.9*	6.9*	5.8*	5.8*							4.6*	4.6*	13.5	

Height Can be slewed through 360° In longitudinal position of undercarriage Max. reach * Limited by hydr. capacity

The lift capacities on the stick end without attachment are stated in metric tons (t) and can be slewed through 360° on a firm, level supporting surface. Capacities are valid for 600 mm wide flat pads. Indicated loads based on the ISO 10567 standard and do not exceed 75% of tipping or 87% of hydraulic capacity. The lift capacity values indicated are attained at the corresponding operating temperature. This operating temperature is ensured by continuous movement of the boom. Weights of fitted attachments (grabs, load hooks, etc.) and load accommodation attachment are to be deducted from the lift capacity values. The lift capacity of the unit is limited by its stability, the lifting capability of the hydraulic elements, or the maximum permissible lifting capacity of the load hook. In accordance with the harmonised European Standard EN 474-5, hydraulic excavators used for lifting operations must be equipped with pipe fracture safety valves, an overload warning device, a load hook and a lift capacity chart.

LH 50 M HR – Equipment AG18

Port – Kinematic 2D

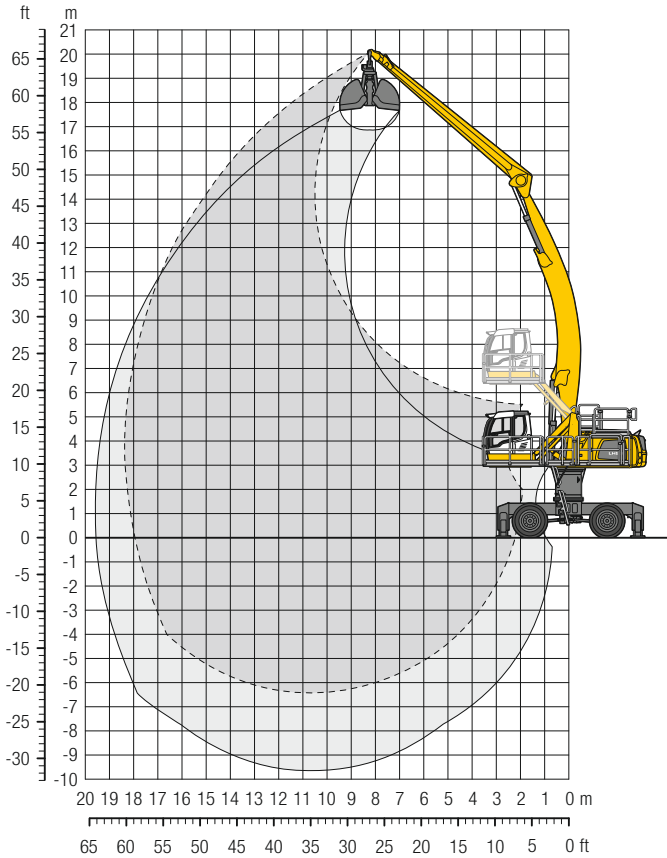

Dimensions

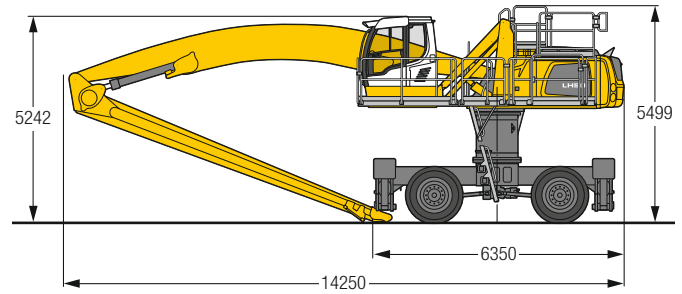

Operating weight

The operating weight includes the basic machine with 4 point outriggers, turret 1,200 mm, hydr. cab elevation, 4 solid tyres, angled boom 10.60m, straight stick 8.70m and grab for loose material GMZ 40 / 2.00 m³.

Weight 50,100 kg

m	Undercarriage	4.5m		6.0m		7.5m		9.0m		10.5m		12.0m		13.5m		15.0m		16.5m		18.0m		Grab		m
		Max. reach	Height	Max. reach	Height	Max. reach	Height	Max. reach	Height	Max. reach	Height	Max. reach	Height	Max. reach	Height	Max. reach	Height	Max. reach	Height	Max. reach	Height	Max. reach	Height	
19.5	4 pt. outriggers down							5.0*	5.0*													4.7*	4.7*	9.3
18.0	4 pt. outriggers down									5.2*	5.2*											4.2*	4.2*	11.5
16.5	4 pt. outriggers down									5.8*	5.8*											3.9*	3.9*	13.1
15.0	4 pt. outriggers down									5.7*	5.7*	5.1*	5.1*									3.7*	3.7*	14.5
13.5	4 pt. outriggers down									5.7*	5.7*	5.2*	5.2*	4.9*	4.9*							3.6*	3.6*	15.5
12.0	4 pt. outriggers down									5.7*	5.7*	5.2*	5.2*	4.8*	4.8*	4.3*	4.3*					3.5*	3.5*	16.4
10.5	4 pt. outriggers down									5.9*	5.9*	5.3*	5.3*	4.9*	4.9*	4.5*	4.5*					4.2*	4.2*	17.0
9.0	4 pt. outriggers down							6.8*	6.8*	6.0*	6.0*	5.4*	5.4*	5.0*	5.0*	4.6*	4.6*	4.2*	4.2*			3.5*	3.5*	17.6
7.5	4 pt. outriggers down					8.3*	8.3*	7.1*	7.1*	6.2*	6.2*	5.6*	5.6*	5.1*	5.1*	4.6*	4.6*	4.3*	4.3*			3.6*	3.6*	18.0
6.0	4 pt. outriggers down			10.8*	10.8*	8.8*	8.8*	7.5*	7.5*	6.5*	6.5*	5.7*	5.7*	5.2*	5.2*	4.7*	4.7*	4.3*	4.3*	3.9*	3.9*	3.6*	3.6*	18.2
4.5	4 pt. outriggers down	16.0*	16.0*	11.8*	11.8*	9.4*	9.4*	7.8*	7.8*	6.7*	6.7*	5.9*	5.9*	5.3*	5.3*	4.8*	4.8*	4.3*	4.3*	3.9*	3.9*	3.7*	3.7*	18.3
3.0	4 pt. outriggers down	6.5*	6.5*	12.6*	12.6*	9.9*	9.9*	8.2*	8.2*	7.0*	7.0*	6.1*	6.1*	5.4*	5.4*	4.8*	4.8*	4.3*	4.3*	3.9*	3.9*	3.8*	3.8*	18.3
1.5	4 pt. outriggers down	4.4*	4.4*	10.1*	10.1*	10.3*	10.3*	8.4*	8.4*	7.1*	7.1*	6.2*	6.2*	5.4*	5.4*	4.8*	4.8*	4.3*	4.3*	3.8*	3.8*	3.7*	3.7*	18.2
0	4 pt. outriggers down	4.3*	4.3*	7.7*	7.7*	10.4*	10.4*	8.5*	8.5*	7.2*	7.2*	6.2*	6.2*	5.4*	5.4*	4.8*	4.8*	4.2*	4.2*			3.6*	3.6*	18.0
-1.5	4 pt. outriggers down	4.6*	4.6*	7.2*	7.2*	10.2*	10.2*	8.5*	8.5*	7.1*	7.1*	6.1*	6.1*	5.3*	5.3*	4.7*	4.7*	4.0*	4.0*			3.5*	3.5*	17.6
-3.0	4 pt. outriggers down	5.1*	5.1*	7.3*	7.3*	9.8*	9.8*	8.1*	8.1*	6.9*	6.9*	5.9*	5.9*	5.1*	5.1*	4.4*	4.4*	3.6*	3.6*			3.3*	3.3*	17.1
-4.5	4 pt. outriggers down			7.6*	7.6*	8.9*	8.9*	7.5*	7.5*	6.4*	6.4*	5.5*	5.5*	4.7*	4.7*	3.9*	3.9*					3.3*	3.3*	16.1
-6.0	4 pt. outriggers down							6.6*	6.6*	5.7*	5.7*	4.8*	4.8*									4.1*	4.1*	13.4

Height
 Can be slewed through 360°
 In longitudinal position of undercarriage
 Max. reach
 * Limited by hydr. capacity

The lift capacities on the stick end without attachment are stated in metric tons (t) and are valid on a firm, level supporting surface with blocked oscillating axle. These capacities can be slewed through 360° with the undercarriage in the transverse position. Capacities in the longitudinal position of the undercarriage (±15°) are specified over the rigid axle with the stabilizers down. Indicated loads based on the ISO 10567 standard and do not exceed 75% of tipping or 87% of hydraulic capacity. The lift capacity values indicated are attained at the corresponding operating temperature. This operating temperature is ensured by continuous movement of the boom. Weights of fitted attachments (grabs, load hooks, etc.) and load accommodation attachment are to be deducted from the lift capacity values. The lift capacity of the unit is limited by its stability, the lifting capability of the hydraulic elements, or the maximum permissible lifting capacity of the load hook. In accordance with the harmonised European Standard EN 474-5, hydraulic excavators used for lifting operations must be equipped with pipe fracture safety valves, an overload warning device, a load hook and a lift capacity chart.

LH 50 C HR – Equipment GG19

Port – Kinematic 2A

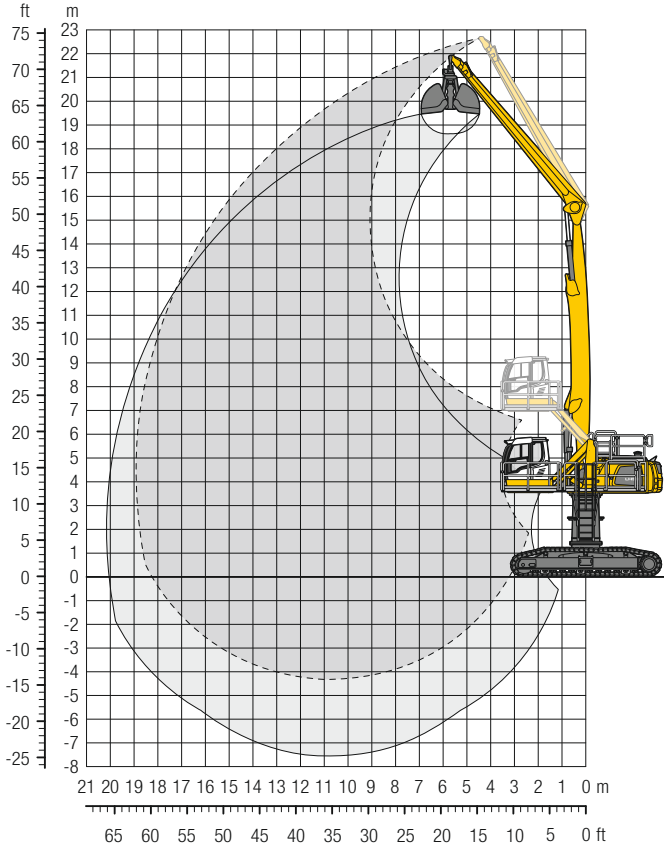

Dimensions

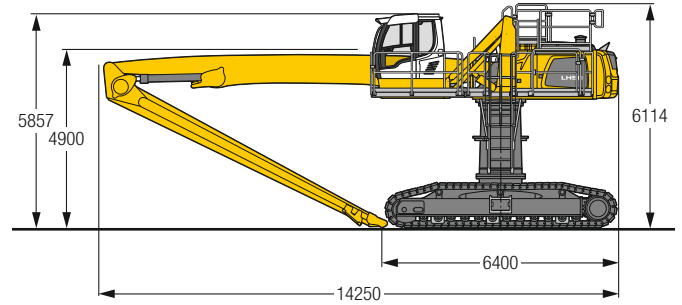

Operating weight and ground pressure

The operating weight includes the basic machine with turret 2,000 mm, hydr. cab elevation, straight boom 10.60 m, straight stick 8.70 m and grab for loose material GMZ 40 / 2.00 m³.

Weight	57,300 kg
Pad width	750 mm
Ground pressure	on request

m	Undercarriage	4.5 m		6.0 m		7.5 m		9.0 m		10.5 m		12.0 m		13.5 m		15.0 m		16.5 m		18.0 m		Max. reach		m
		SW	SW	SW	SW	SW	SW	SW	SW	SW	SW	SW	SW	SW	SW	SW	SW	SW	SW	SW	SW	SW	SW	
22.5	SW																					7.8*	7.8*	5.1
21.0	SW					7.1*	7.1*															5.6*	5.6*	8.9
19.5	SW							7.0*	7.0*	5.8*	5.8*											4.8*	4.8*	11.3
18.0	SW							7.5*	7.5*	6.7*	6.7*	5.7*	5.7*									4.3*	4.3*	13.1
16.5	SW							7.4*	7.4*	6.6*	6.6*	6.0*	6.0*	5.4*	5.4*							4.0*	4.0*	14.5
15.0	SW									6.5*	6.5*	5.9*	5.9*	5.4*	5.4*	4.9*	4.9*					3.8*	3.8*	15.6
13.5	SW							7.4*	7.4*	6.6*	6.6*	5.9*	5.9*	5.4*	5.4*			3.8*	3.8*			3.7*	3.7*	16.6
12.0	SW							7.5*	7.5*	6.6*	6.6*	6.0*	6.0*	5.4*	5.4*	5.0*	5.0*	4.6*	4.6*			3.6*	3.6*	17.3
10.5	SW							7.6*	7.6*	6.8*	6.8*	6.0*	6.0*	5.5*	5.5*	5.0*	5.0*	4.6*	4.6*			3.5*	3.5*	17.9
9.0	SW					9.2*	9.2*	7.9*	7.9*	6.9*	6.9*	6.2*	6.2*	5.5*	5.5*	5.0*	5.0*	4.6*	4.6*	4.1*	4.1*	3.5*	3.5*	18.3
7.5	SW			9.7*	9.7*	9.7*	9.7*	8.2*	8.2*	7.1*	7.1*	6.3*	6.3*	5.6*	5.6*	5.1*	5.1*	4.6*	4.6*	4.1*	4.1*	3.5*	3.5*	18.7
6.0	SW	16.9*	16.9*	12.7*	12.7*	10.2*	10.2*	8.5*	8.5*	7.3*	7.3*	6.4*	6.4*	5.7*	5.7*	5.1*	5.1*	4.5*	4.5*	4.0*	4.0*	3.6*	3.6*	18.8
4.5	SW	7.1*	7.1*	13.4*	13.4*	10.6*	10.6*	8.8*	8.8*	7.5*	7.5*	6.5*	6.5*	5.7*	5.7*	5.1*	5.1*	4.5*	4.5*	3.9*	3.9*	3.4*	3.4*	18.9
3.0	SW	2.8*	2.8*	10.5*	10.5*	10.8*	10.8*	8.9*	8.9*	7.5*	7.5*	6.5*	6.5*	5.7*	5.7*	5.0*	5.0*	4.4*	4.4*	3.7*	3.7*	3.1*	3.1*	18.9
1.5	SW	2.6*	2.6*	6.6*	6.6*	10.8*	10.8*	8.9*	8.9*	7.5*	7.5*	6.5*	6.5*	5.6*	5.6*	4.9*	4.9*	4.2*	4.2*	3.4*	3.4*	2.9*	2.9*	18.7
0	SW	3.1*	3.1*	5.9*	5.9*	10.4*	10.4*	8.6*	8.6*	7.3*	7.3*	6.3*	6.3*	5.4*	5.4*	4.6*	4.6*	3.9*	3.9*	2.9*	2.9*	2.7*	2.7*	18.2
-1.5	SW	3.8*	3.8*	6.1*	6.1*	9.6*	9.6*	8.1*	8.1*	6.9*	6.9*	5.9*	5.9*	5.0*	5.0*	4.2*	4.2*	3.4*	3.4*			2.9*	2.9*	17.1
-3.0	SW					8.4*	8.4*	7.2*	7.2*	6.1*	6.1*	5.2*	5.2*	4.4*	4.4*	3.5*	3.5*					3.3*	3.3*	15.3

Height Can be slewed through 360° In longitudinal position of undercarriage Max. reach * Limited by hydr. capacity

The lift capacities on the stick end without attachment are stated in metric tons (t) and can be slewed through 360° on a firm, level supporting surface. Capacities are valid for 750 mm wide flat pads. Indicated loads based on the ISO 10567 standard and do not exceed 75% of tipping or 87% of hydraulic capacity. The lift capacity values indicated are attained at the corresponding operating temperature. This operating temperature is ensured by continuous movement of the boom. Weights of fitted attachments (grabs, load hooks, etc.) and load accommodation attachment are to be deducted from the lift capacity values. The lift capacity of the unit is limited by its stability, the lifting capability of the hydraulic elements, or the maximum permissible lifting capacity of the load hook. In accordance with the harmonised European Standard EN 474-5, hydraulic excavators used for lifting operations must be equipped with pipe fracture safety valves, an overload warning device, a load hook and a lift capacity chart.

Equipment

 Undercarriage	40 M	40 C	50 M HR	50 C HR
Support assistant	+		+	
Track pads, variants		+		+
Individual control outriggers	+		•	
Three-piece chain guide		+		•
Shuttle axle lock, automatic	•		•	
Outrigger monitoring system	+		+	
Tyres, variants	+		+	
Trailing cable ²⁾	•	•		
Protection for piston rods, outriggers	+		+	
Two storage compartments ¹⁾	•			
One storage compartment ²⁾	•			
Cable reel system ²⁾	+			

 Upper-carriage	40 M	40 C	50 M HR	50 C HR
Upper-carriage right side light, 1 piece, LED	•	•	•	•
Upper-carriage rear light, 2 pieces, LED	+	+		
Upper-carriage underneath rear light, 1 piece, LED			+	+
Refuelling system with filling pump ¹⁾	+	+	+	+
Railing on upper-carriage	+	+	•	•
Generator	+	+	+	+
Main battery switch for electrical system	•	•	•	•
Amber beacon, at upper-carriage, LED double flash	+	+	+	+
Protection for headlights	+	+		
Protection for rear lights	+	+		
Tool equipment, extended	•	•	•	•

 Hydraulic system	40 M	40 C	50 M HR	50 C HR
Electronic pump regulation	•	•	•	•
Liebherr hydraulic oil from -20 °C to +40 °C	•	•	•	•
Liebherr hydraulic oil, biologically degradable	+	+	+	+
Liebherr hydraulic oil, specially for warm or cold regions	+	+	+	+
Magnetic rod in hydraulic tank	•	•	•	•
Bypass filter	+	+	+	+
Preheating hydraulic oil	+	+	+	+

 Engine	40 M	40 C	50 M HR	50 C HR
Fuel anti-theft device ¹⁾	+	+	+	+
Air pre-filter with dust discharge ¹⁾	+	+	+	+
Automatic engine shut-down (time adjustable)	+	+	+	+
Preheating fuel ¹⁾	+	+	+	+
Preheating coolant ¹⁾	+	+	+	+
Preheating engine oil* ¹⁾	+	+	+	+

 Cooling system	40 M	40 C	50 M HR	50 C HR
Reversible fan drive	+	+	+	+
Protective grid in front of cooler intake	•	•	•	•



Cab

	40 M	40 C	50 M HR	50 C HR
Stabilizer, control lever, left console	+		+	
Stabilizer, proportional control on left joystick	●		●	
Cab lights rear, LED	+	+	+	+
Cab lights front, LED	+	+	+	+
Cab lights front, LED (under rain cover)	●	●	●	●
Armrest adjustable	●	●	●	●
Circular bubble level	+	+	+	●
Slewing gear brake Comfort, button on the left or right joystick	+	+	+	+
Driver profile, personalised (max. 5 drivers)	+	+	+	+
Operator's seat Comfort	●	●	●	●
Operator's seat Premium	+	+	+	+
Driving alarm				
(acoustic signal is emitted during travel, can be switched ON/OFF)	+	+	+	+
Fire extinguisher	+	+	+	+
Footrest	+	+	+	+
Horn, button on left joystick	●	●	●	●
Joystick steering (max. 12 km/h)	●		●	
Joystick and wheel steering (slim version)	+	+	+	
Cab elevation, hydraulic (LHC)	●	●	●	●
Cab elevation, hydraulic with tilt function (LHC)	+	+		
Cab elevation, rigid (LFC)	+	+		
Automatic air conditioning	●	●	●	●
Wheel steering (slim version)	+		+	
LiDAT, vehicle fleet management	●	●	●	●
Engine shut-down (emergency stop) cab ²⁾	●	●	●	●
Proportional control	●	●	●	●
Radio Comfort, control via display with handsfree set	+	+	+	+
Preparation for radio installation	●	●	●	●
Back-up alarm				
(acoustic signal is emitted traveling backward, can not be switched off)	+		+	
Amber beacon, on cab, LED double flash	+	+	+	+
Windows made from impact-resistant laminated safety glass	+	+	●	●
Windscreen wiper, roof	+	+	+	+
Windshield wiper, entire windscreen	●	●	●	●
FOPS top guard	+	+	+	+
FGPS front guard, tiltable	+	+	+	+
Sun visor	+	+	+	+
Stationary air-conditioning ²⁾	●	●	●	●
Left control console, folding	●	●	●	●



Equipment

	40 M	40 C	50 M HR	50 C HR
Boom lights, 2 pieces, LED	●	●	●	●
Stick lights, 2 pieces, LED	●	●	●	●
Boom shutoff (retract/extend), electronically	+	+	+	+
Equipment with electro-hydraulic end position control	●	●	●	●
AutoLift	+	+	+	+
Pressure warning mechanism hoist cylinder	●	●	●	●
ERC system	●	●	●	●
Filter system for attachment	+	+	+	+
Electronic lift limitation	+	+	+	+
Boom cylinder cushioning	●	●	●	●
Stick camera (with separate monitor), bottom side, with protection	+	+	+	+
Load torque limitation	+	+	+	+
Liebherr multi coupling system	+	+	+	+
Pipe fracture safety valves hoist cylinders	●	●	●	●
Pipe fracture safety valves stick cylinders	●	●	●	●
Quick coupling system MH 40B	+	+	+	+
Protection for piston rod, energy recovering cylinder	+	+	+	+
Protection for piston rods, hoist cylinder	+	+	+	+
Stick shutoff (retract), electronically	●	●	●	●
Stick shutoff (retract/extend), electronically	+	+	+	+
Retract stick without pressure	●	●	●	●
Sticks with quick coupling	+	+	+	+
Overload warning device	+	+	+	+



Complete machine

	40 M	40 C	50 M HR	50 C HR
Lubrication				
Lubrication undercarriage, manually - decentralised (grease points)	●			
Lubrication undercarriage, manually - centralised (one grease point)	+		●	
Central lubrication system for uppercarriage and equipment, automatically	+	●	●	●
Central lubrication system for undercarriage, automatically	+		+	
Centralised lubrication extended for attachment	+	+	+	+
Special coating				
Special coating, variants	+	+	+	+
Monitoring				
Rear view monitoring with camera	●	●	●	●
Side view monitoring with camera	●	●	●	●

● = Standard, + = Option

* = country-dependent, ¹⁾ not with electric drive, ²⁾ only with electric drive

Options and / or special equipment, supplied by vendors other than Liebherr, are only to be installed with the knowledge and approval of Liebherr in order to retain warranty.

Attachments

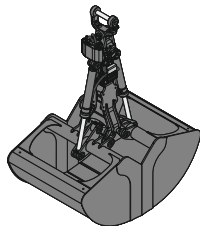

Grab for loose material

Shells for loose material with cutting edge (without teeth)

Grab model GMZ 40		Shells for loose material with cutting edge (without teeth)											
Shell specification		Standard						Wide					
Width of shells	mm	1,190	1,500	1,750	1,900	2,150	2,500	1,190	1,500	1,750	2,000	2,250	2,500
Capacity	m ³	2.10	2.50	3.00	3.50	4.00	4.50	1.20	1.50	1.75	2.00	2.25	2.50
Weight	kg	1,740	1,885	2,005	2,080	2,340	2,495	1,540	1,665	1,770	1,875	2,050	2,155

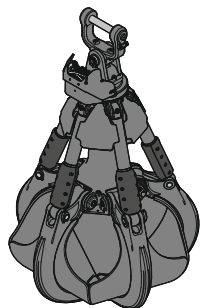

Multi-tine grab

closed, heart-shaped

Grab model GMM 50-5 (5 tines)		Shells for loose material with cutting edge (without teeth)											
Capacity	m ³	0.70						0.90					1.10
Weight	kg	1,790						1,950					1,955

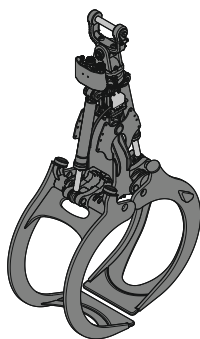

Wood grab

Grab model GMH 40 – round overlapping (vertical cylinders)		Shells for loose material with cutting edge (without teeth)										
Size	m ²	1.00	1.30			1.50		1.70			1.90	
Cutting width	mm	810	810			810		810			810	
Height of grab, closed	mm	2,576	2,679			2,723		2,816			2,900	
Weight	kg	1,575	1,605			1,655		1,660			1,790	

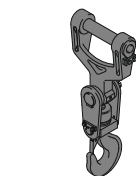

Load hook

Max. load	t	12.5
Height with suspension	mm	930
Weight	kg	135

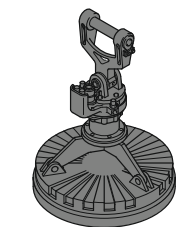

Magnet devices / lifting magnets

Generator	kW	13/17
Electromagnet with suspension		
Power	kW	8.8
Diameter of magnet	mm	1,250
Weight	kg	1,310*
		1,700*

* only magnet plate

Liebherr-Hydraulikbagger GmbH

Liebherrstraße 12 • 88457 Kirchdorf/Iller, Germany • Phone +49 7354 80-0 • Fax +49 7354 80-72 94
 info.lhb@liebherr.com • www.liebherr.com • www.facebook.com/LiebherrConstruction