

---

# LH 80 Industry Litronic

---

## LIEBHERR

Material handling machine

### Generation

6

### Operating weight

66,500–120,500 kg\*

### Engine

Stage V

Stage IIIA (compliant)

Tier 4 Final

Electric

\* Without attachment

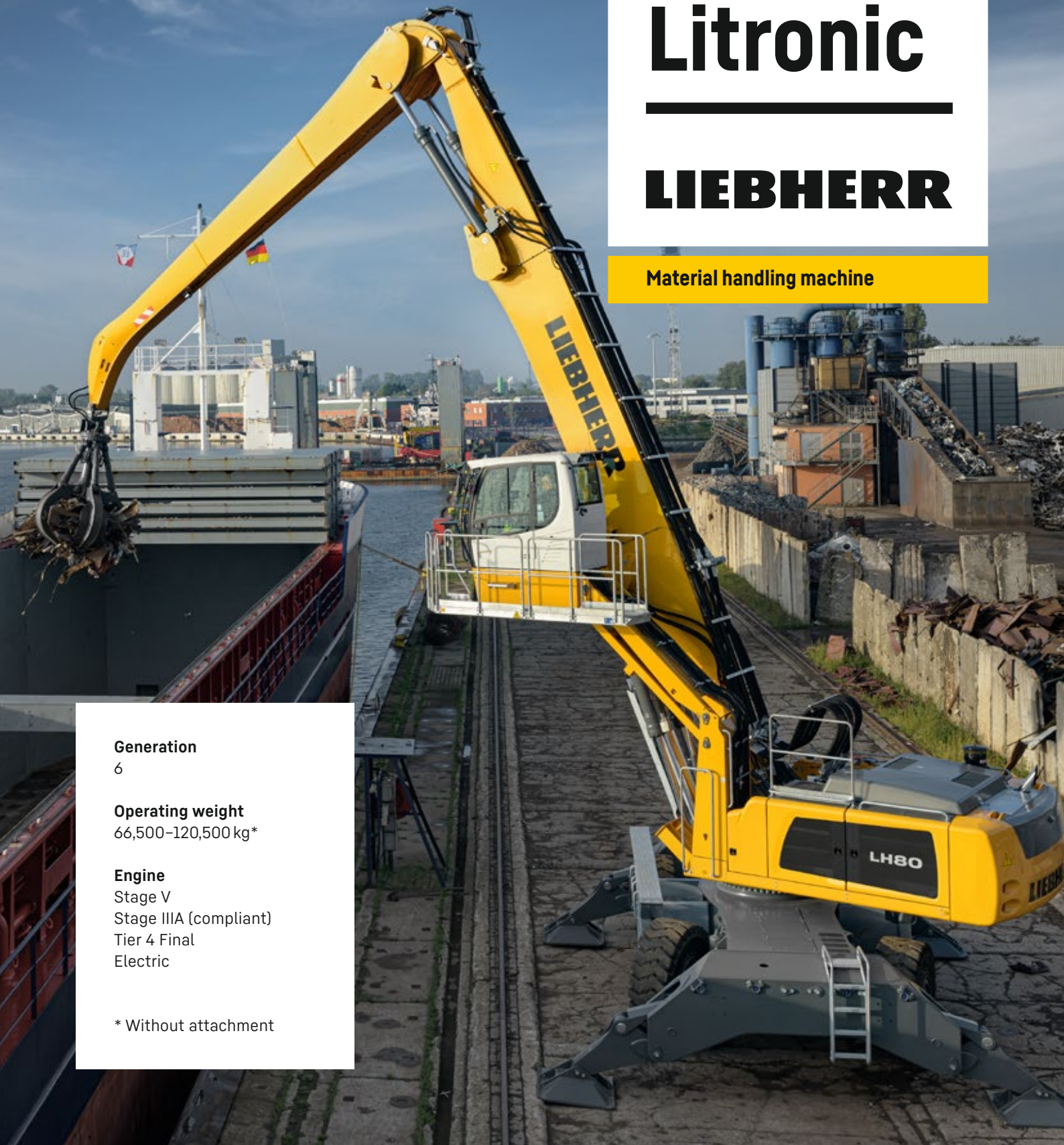

## Performance

Power plus speed –  
Redefined performance

## Economy

Good investment –  
Savings for long-term

## Reliability

Durability and sustainability –  
Quality down to the last detail

## Comfort

Perfection at a glance –  
When technology is comfortable

## Maintainability

Efficiency bonus –  
Even with maintenance and service



### LH 80 M Industry Litronic

**Operating weight**

71,500–82,500 kg\*

**Engine**

230 kW / 313 HP (Diesel)  
220 kW (Electric)  
Stage V  
Stage IIIA (compliant)  
Tier 4 Final  
Electric

**System performance**

437 kW (Diesel)  
427 kW (Electric)

### LH 80 M High Rise Industry Litronic

**Operating weight**

86,500–99,800 kg\*

**Engine**

230 kW / 313 HP (Diesel)  
220 kW (Electric)  
Stage V  
Stage IIIA (compliant)  
Tier 4 Final  
Electric

**System performance**

437 kW (Diesel)  
427 kW (Electric)

\* Without attachment



## LH 80 C Industry Litronic

**Operating weight**  
66,500–88,000 kg\*

**Engine**  
230 kW / 313 HP (Diesel)  
220 kW (Electric)  
Stage V  
Stage IIIA (compliant)  
Tier 4 Final  
Electric

**System performance**  
437 kW (Diesel)  
427 kW (Electric)

## LH 80 C High Rise Industry Litronic

**Operating weight**  
87,800–103,000 kg\*

**Engine**  
230 kW / 313 HP (Diesel)  
220 kW (Electric)  
Stage V  
Stage IIIA (compliant)  
Tier 4 Final  
Electric

**System performance**  
437 kW (Diesel)  
427 kW (Electric)

## LH 80 C Gantry Industry Litronic

**Operating weight**  
107,200–120,500 kg\*

**Engine**  
230 kW / 313 HP (Diesel)  
220 kW (Electric)  
Stage V  
Stage IIIA (compliant)  
Tier 4 Final  
Electric

**System performance**  
437 kW (Diesel)  
427 kW (Electric)

# Performance

---



## Power plus speed – redefined performance

Liebherr has been designing and manufacturing market leading material handling machines for over 60 years. With the different versions of the LH 80 Industry machine model of the generation of Liebherr handlers, high performance and yet economical machines specially designed for use in scrap recycling, timber yards and for handling of bulk materials.

## Maximum handling capacity

### Powerful drive unit

The LH 80 Industry material handling machine is equipped with a powerful Liebherr 6-cylinder in-line engine with 12.0 l displacement or optionally with a 230 kW electric motor with a frequency converter. This ensures the machine's high performance while further reducing fuel and energy consumption.

### High swing torque

The separate hydraulic pump in the closed slewing circuit only supplies hydraulic fluid to the swing mechanism. The maximum delivery volume is thus available at any time for turning the uppercarriage for fast and dynamic rotational movements.

### Energy recovery system ERC

Lowering the equipment in the ERC system provides the machine with additional stored energy. This results in increased system performance, which in turn enables more powerful, faster and more homogeneous work cycles and increases handling performance.

## Precision operation

### LSC Hydraulic system with electrical pilot control

The 2-circuit Liebherr-Synchron-Comfort-system (LSC) with LUDV technology (flow distribution independent of load pressure) ensures faster working movements with up to 20% less energy consumption.

All work functions of the machine are controlled electrically, whereby the signals of the transmitters are only converted directly at the control block by hydraulic means. This technology enables end position damping of the equipment in order to protect the components and thus extend their service life. Simple, individual setting and adjustment of the working speed of boom, stick and slewing mechanism allow the driver to adjust the machine to each application and fully utilise the machine's capacity.

### Firm and stable positioning

An essential prerequisite for precise working and maximum handling capacity is the firm and stable positioning of the machine. The design of the Liebherr undercarriage optimises the way forces are induced on components to minimise stress and guarantee maximum stability and durability.



### Liebherr diesel engine

- Powerful, robust and reliable
- Maximum torque even at low speeds to ensure fast movements with low fuel consumption
- Common-Rail injection system for maximum efficiency
- Emissions treatment with Liebherr SCR technology at Stage V



### Closed slewing circuit

- High torque for maximum acceleration and fast rotary movements
- Integrated speed sensor for controlling and monitoring braking movement for greater safety
- Greater fuel efficiency thanks to intelligent energy management in the closed system



### Electrical pilot control

- Precision control irrespective of the ambient temperature for maximum precision
- Simpler and faster fault diagnostics for optimal availability
- Up to 5 individual driver profiles can be saved

# Economy

---



## Good investment – savings for the long-term

Liebherr material handling machines combine high productivity with excellent economy – all as standard. Liebherr manages to achieve this difficult goal through sophisticated engine technology from its own production and improved demand-controlled hydraulics.

## Increased productivity

### Engine idling and engine shut-down

The standard automatic idling function reduces the engine speed to idle as soon as the operator takes his hand from the joystick so that no hydraulic function is activated. Proximity sensors in the joystick levers restore the original engine speed as soon as the operator's hand is moved towards the lever again. This ensures that the set engine speed is available immediately. The result is a combination of energy savings and reduced noise levels. Operating costs can be reduced even further with the optional automatic engine shut down function.

### Closed hydraulic circuit for the swing mechanism

The closed slewing circuit feeds the braking energy back into the system when the uppercarriage is braked. Here, new standards are set in terms of efficiency and economy. Simple yet effective.

### Attachments and quick coupling systems

Liebherr offers a wide selection of attachments for every application to increase the productivity of its material handling machines. In addition the material handlers can be fitted with a Liebherr quick coupling system which increase the productivity of the machine by up to 30%. The matching attachment and quick coupling system combined with the outstanding dynamics of a Liebherr handler ensures highest handling capacity and maximum productivity.

## Electrical efficiency

### Electric drive concept

The electric drives offer an economical and sustainable solution in the field of material handling. The drive motors operate in an environmentally friendly and emission-free manner, which makes them independent of any exhaust emission standards. A significant reduction in operating and service costs is achieved due to the elimination of maintenance work such as oil changes and fuelling breaks, as well as longer service intervals compared to diesel models. This increase in efficiency results in optimal working times and increased productivity in the field. In addition, the low-vibration and low-noise operation ensures improved working comfort.

### Sustainable profitability with electric machines

An investment in an electric material handling machine pays off in the long term. These advanced drives offer numerous advantages that enable fast amortisation of the machine and significant cost savings compared to conventional diesel engines. Given the growing importance of environmental criteria and emissions, electric drives are an economical alternative that ensures both sustainable profitability and environmentally friendly operation.

Liebherr Power Efficiency (LPE) System

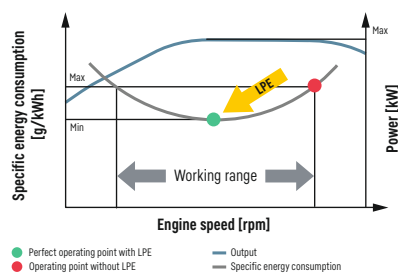

### Low energy consumption thanks to intelligent machine control

- Liebherr-Power Efficiency (LPE) optimises the interaction of the drive components in terms of efficiency
- LPE enables machine operation in the area of the lowest specific energy use for less consumption and greater efficiency with the same performance

### Liebherr attachments

- Robust and service-friendly slewing drive, can be turned 360°
- Optimum filling and clamping performance for effective material handling
- Finite element method (FEM) optimised for a perfect relationship between grapple weight, volume and a very long service life

### Frequency converters

- Individual adjustment of the speed
- Smooth start-up to avoid inrush current peaks and high energy savings due to effective start-up current limitation
- Simple adjustment to all conventional power supply networks

# Reliability

---



## Durability and sustainability – quality down to the last detail

Every day Liebherr material handlers demonstrate their qualities in a range of industrial applications all over the world. Years of experience, continuous development and the latest technologies provide maximum safety in use. Their robust design and the use of components produced in-house ensure that the LH 80 is designed for a long service life.



## More safety

### Pipe fracture safety valves

The standard pipe fracture safety valves on the stick and hoist cylinders prevent the equipments from dropping in an unregulated way and ensure maximum safety during every operation.

### Working range limiters

For operations in which the working range should be limited, the material handling machines can be optionally equipped with a working range limitation feature. Collisions and resulting component damage can thus be avoided.

### Overload warning device and load torque limitation

The audible and visual overload warning system continuously tells the operator about the current load situation of the machine. Furthermore, load torque limitation automatically regulates the speed of the working hydraulics to allow the maximum load bearing capacity to be approached safely. In the event of an overload, the functions which could cause the machine to topple are disabled. Only movements back to the safe working range are then possible.

## High machine availability

### Quality and competence

Our experience, understanding of customer needs and the technical implementation of these findings guarantee the success of our products. For decades, Liebherr has been inspirational with its depth of production and system solutions. Key components such as the diesel engine, electronic components, slew ring, swivel drive and hydraulic cylinders are developed and produced by Liebherr itself. The extent of in-house manufacturing guarantees maximum quality and ensures that components are optimally configured to each other.

### Robust design

All steel components are designed and manufactured by Liebherr. High-strength steel plates configured for the toughest of requirements result in high torsional stiffness and optimum absorption of forces induced for a longer service life.

### Intelligent self diagnostics

The innovative control electronics permanently monitor the vital functions of the machine to guarantee a high level of machine availability. Components which are critical for safety are designed with redundancy to guarantee maximum reliability.



### QPDM – Quality and process data management

- QPDM allows production data to be logged, documented and evaluated
- Automation of documentation and test specifications
- Ability to handle large quantities of data while maintaining uniform high quality



### Piston rod protection

- Maximum protection of piston rod
- Robust construction of hot-dip galvanized steel for a long service life in tough applications
- Available for outriggers, hoist cylinders, ERC cylinder and tip cylinder as an option



### Equipment

- Components enhanced using FEM for maximum service life even if subjected to heavy lateral stresses during demanding tasks
- Cables routed internally to protect them from damage
- High load capacities with long reaches
- Reaches up to 19m

# Comfort

---



## Perfection at a glance – when technology is comfortable

The Liebherr deluxe cab is spacious, has an ergonomic design and is very quiet. This ensures that the operator remains intent and fully concentrated throughout the working day and enables him to deliver a constantly high performance.

## Deluxe cab

### Ergonomic design

The cab design provides excellent conditions for healthy, focussed and productive work in maximum comfort. The colour touchscreen display, the controls and operator's Comfort seat are all coordinated to form a perfect ergonomic unit. In addition the ergonomic joysticks allow the machine operation to be both pleasant and precise.

### Excellent all-round vision

The large areas of glass, different versions of cab elevations and the rear and side area monitoring systems provide the operator with an excellent view of their working area and the zone around the machine. This perfect view enhances the operator's safety and ensures that they can handle the machine safely at all times.

### Low noise levels

The use of viscoelastic mounts, good insulation and low noise diesel engines from Liebherr minimises noise emissions and vibrations. Both electric and diesel-powered machines produce extremely low sound levels, which means they are classed as low-noise machines that are not harmful to people and the environment.

## Comfortable operation

### Proportional control

Precision control of the material handling machine is especially important in applications such as scrap recycling or when handling bulk material. Thanks to the standard proportional control, even such demanding operations can be mastered in style.

### Joystick steering and stabilizing

The standard joystick steering gives the operator an additional comfort boost. The steering movement can be conveniently executed using the joystick, eliminating the need to reposition during the work cycle. Substituting the steering wheel in favour of joystick steering provides additional legroom and a clear view of the working area. A standard feature is the control of the outriggers with the joystick for more comfort and an increased productivity of the machine.

### Colour touchscreen display and operation unit

The 9" colour touchscreen display is intuitive in its operation and provides continuous information about all important operating data. The shortcut keys can be individually assigned and are selected quickly and easily with the menu strip.



### Safe access

- Foldable left arm console as well as wide, non-slip steps, catwalks and platforms, and ergonomically positioned handles for easy and safe access
- All access systems are designed to national guidelines and statutory regulations
- Sliding door for comfortable entry with narrow platforms is available as an option



### Operator's seat comfort with adjustable armrests

- Greater seating comfort due to variable damper hardness, lockable horizontal suspension, pneumatic lumbar support, seat heating and passive seat air conditioning for concentrated working
- Individual adjustment options for armrests, seat cushion depth, seat angle and head restraint for comfortable working



### Joystick with proportional control

- Good functionality with streamlined, ergonomic design
- 4-way mini joystick can be used to control all operations e.g. steering, outriggers and attachments etc.
- Joysticks - each with two buttons and a rocker switch - increase the number of functions available

# Maintainability

---



## Efficiency bonus – even with maintenance and service

The Liebherr LH 80 material handling machine is powerful, robust, precise and efficient. It also features integral maintenance benefits as a result of their service-based machine design. The maintenance work for the Liebherr material handler can be carried out quickly, easily and safely. This minimises machine's maintenance costs and downtime.

## Efficient maintenance concept

### Service-based machine design

The service-based machine design guarantees short servicing times, thus minimising maintenance costs. All the service points are positioned in close proximity to one another, are easily accessible from the ground or from catwalks and platforms, and easy to reach thanks to the large, wide-opening service doors. This means that service work can be completed even more quickly and efficiently.

### Integral maintenance benefits

Maintenance work helps to keep the machine fully functional. However this kind of work leads to machine downtimes which have to be minimised. With change intervals of up to 2,000 hours for engine oil and up to 8,000 hours for hydraulic oil, Liebherr has significantly reduced the amount of maintenance and increased the productivity of the material handlers. In addition, central lubrication systems minimise daily maintenance. Above all, electric material handling machines are characterised by their low maintenance requirements.

## Your competent service partner

### Remanufacturing

The Liebherr remanufacturing program offers cost-effective reconditioning of components to the highest quality standards. Various reconditioning levels are available: Replacement components, general overhaul or repair. The customer receives components with original part quality at a reduced cost.

### Competent advice and service

Competent advice is a given at Liebherr. Experienced specialists provide decision guidance for your specific requirements: application-oriented sales support, service agreements, economical repair alternatives, original parts management, as well as remote data transmission for machine planning and fleet management.

### Fast spare parts service

The Liebherr spare parts service provides 24-hour delivery and is therefore available to our dealers around the clock. Thanks to the electronic spare parts catalogue the parts can be selected and ordered quickly and reliably using the Liebherr online portal. Your order can be tracked at any time using the online tracking system.



### Lubrication as it works

- Fully automatic central lubrication system for uppercarriage and equipment
- Fully automatic central lubrication system for the undercarriage and attachments available as an option
- Lubricates without interrupting work to ensure better productivity and a long component service life



### Servicing advantages for electrical machines

- Low operating and maintenance costs
- Significantly longer maintenance intervals compared to diesel engines due to a lower number of wear parts
- Cost savings on servicing
- Maximum productivity due to permanent readiness of the machine



### SCRFilter for stage V

- The SCR filter system developed by Liebherr includes a DOC catalyst, an SCR catalyst and an SCR-coated particulate filter
- The DOC catalyst requires no maintenance and the coated particulate filter is regenerated passively
- The maintenance intervals can be extended to more than 4,500 operating hours

# Material handling machines overview

## Equipment

- High load capacities and long reaches thanks to optimised kinematic properties and robust construction for greater handling performance
- Energy recovery cylinder filled with nitrogen for maximum efficiency through less energy consumption at more handling capacity
- Pipe fracture safety valves on hoist and stick cylinders and retract stick shut-off for maximum safety during every application
- Quick coupling systems and attachments made by Liebherr for maximum machine capacity utilisation and greater handling performance

## Operator's Cab

- Joystick steering without steering column as standard for convenient operation, greater legroom and clear view of the working area
- Less strain on the operator, workers and reduced environmental pollution due to lower noise emissions
- Optimum visibility thanks to large glass surfaces and standard rear and side area monitoring with camera
- Proportional control as standard with 4-way mini joystick for greater precision, high precision control and functions





## Uppercarriage

- 2-circuit Liebherr-Synchron-Comfort-system (LSC) with LUDV technology for faster working speed at up to 20% less energy consumption
- 230 kW engine output and greater pump flow for fast work cycles and maximum handling performance
- Electrical pilot control enables individual settings for the operator and an end position damping of the equipment
- Reduction in operating costs thanks to built-in maintenance advantages and optimum service accessibility
- Frequency converter provides the direct energy supply and control for the electric motor\*

## Undercarriage

- Optimised hydraulics with closed slewing mechanism circuit for greater energy efficiency and faster work cycles
- Central lubrication system (manual/ fully automatic) for more productive working time (optional available)
- Load-holding valves fitted as standard on all support cylinders for maximum stability in every application
- Low service costs thanks to travel drive without gearbox and cardan shafts
- Different cable variants for flexible applications and high mobility\*

\* only with electric

# The perfect solution for every application

## Attachments

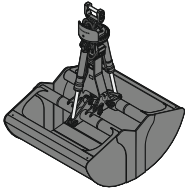

Shells for loose material



Multi-tine grab



Wood grab

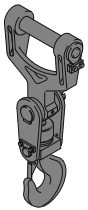

Load hook

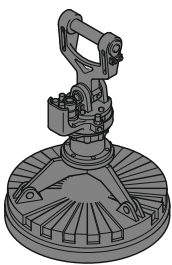

Magnet devices

## Sticks

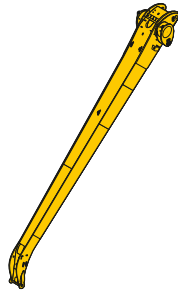

Angled stick

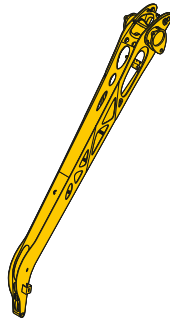

Lightweight stick

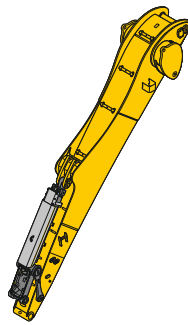

Stick with tipping kinematics

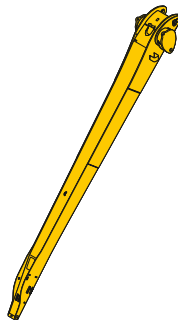

Straight stick

## Booms

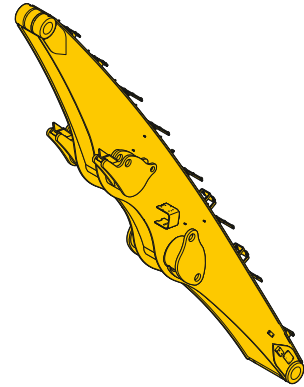

Straight boom

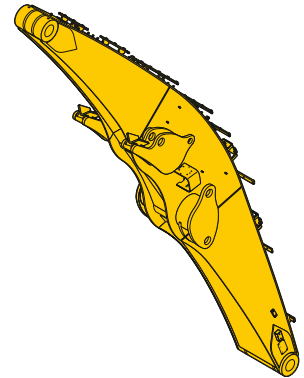

Angled boom



## Cab elevations

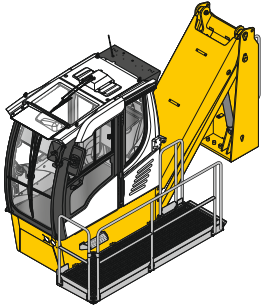

Hydraulic cab elevation

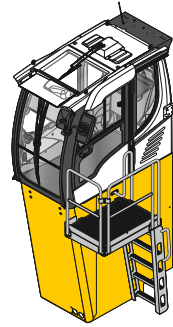

Rigid cab elevation

---

## Uppercarriage

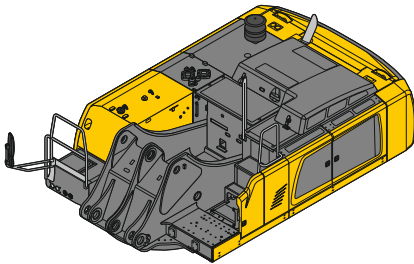

Diesel

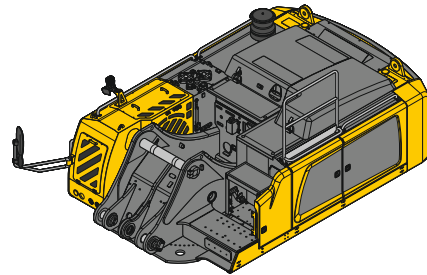

Electric

---

## Turret elevations



---

## Undercarriage

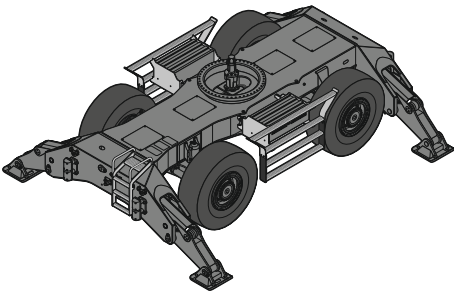

Mobile

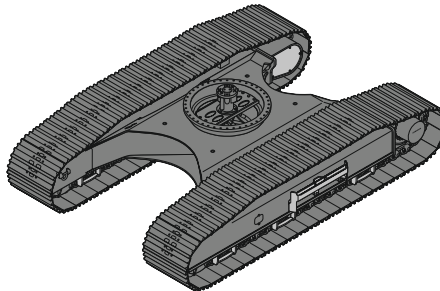

Crawler

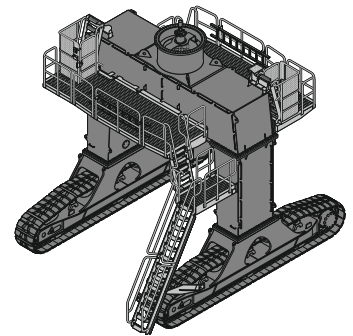

Gantry

# Experience the progress

The invention of the mobile tower crane in 1949 also marked the birth of the Liebherr company. During its first decade the small construction company developed into an established manufacturer of construction machines and other technically advanced products. The R 353 and its first industrial equipment were launched in 1951 to lay the

foundations for the production of today's material handling machines. The A 911 mobile material handling machine a few years later enabled the company to make the breakthrough into material handling. Over the years the machines have been developed continually and today they are designed uncompromising for the industrial use.

**1949**

First tower crane TK10



**1968**

Breakthrough with the A 911 mobile material handler



**1974**

Silenced material handling machine



R 353 with the first industrial equipment

**1961**



Production plant in Kirchdorf

**1970**



First hydraulic cab elevation

**1983**

Liebherr has now been developing and manufacturing material handling machines for a very wide range of applications in the scrap, port and timber handling sectors and for the waste and recycling industry for over 60 years. In the development of its machines, Liebherr chooses quality, durability and reliability from the very outset, together with performance and economy. Years of experience in design and con-

struction are not only reflected in the end product but also in the components which are developed, designed and manufactured by Liebherr itself. This multiple sector expertise is used in product design from the early phase of the development process and thus allows high level technical innovations to be made.

**2007**

Opening of the assembly building for material handling machines



**2013**

Launch of the new LH series



**2016**

Launch of the new port material handling machines



Awarded the Bauma Design Prize for the LH 120

**2010**



Awarded the Bauma Innovation Prize for the ERC cylinder



Awarded the IF Award for the material handling machine LH 60

**2014**

# Technical data



## Diesel engine

<b>Rating per ISO 9249</b>	230 kW (313 HP) at 1,800 RPM
<b>Model</b>	Liebherr D946
<b>Type</b>	6 cylinder in-line
<b>Bore / Stroke</b>	130 / 150 mm
<b>Displacement</b>	11.95 l
<b>Engine operation</b>	4-stroke diesel Common-Rail Turbo-charged and after-cooled Reduced emissions
<b>Air cleaner</b>	Dry-type air cleaner with pre-cleaner, primary and safety elements
<b>Engine idling</b>	Sensor controlled
<b>Electrical system</b>	
<b>Voltage</b>	24 V
<b>Batteries</b>	2 x 180 Ah / 12 V
<b>Alternator</b>	Three-phase current 28 V / 140 A
<b>Stage V</b>	
<b>Harmful emissions values</b>	According to regulation (EU) 2016/1628
<b>Emission control</b>	Liebherr-SCR Filter technology
<b>Fuel tank</b>	660 l
<b>Urea tank</b>	65 l
<b>Stage IIIA (compliant)</b>	
<b>Harmful emissions values</b>	In accordance with ECE-R.96 Power Band H
<b>Fuel tank</b>	660 l
<b>Tier 4 Final</b>	
<b>Harmful emissions values</b>	In accordance with 40CFR1039 (EPA) / 13CCR (CARB)
<b>Emission control</b>	Liebherr-SCR technology
<b>Fuel tank</b>	660 l
<b>Urea tank</b>	65 l



## Electric motor

<b>Rating</b>	220 kW at 1,800 RPM
<b>Type</b>	Three-phase squirrel cage motor
<b>Secondary electric motor</b>	Electric motor auxiliary equipment (air-conditioning compressor, alternator 24 V) 15 kW
<b>Electrical system energy supply</b>	Frequency converter fed drive system Heavy-duty version
<b>Supply voltage</b>	
<b>Low voltage</b>	380 V, 400 V
<b>Frequency</b>	50 / 60 Hz
<b>Engine idling</b>	Sensor controlled
<b>Electrical system</b>	Battery-assisted Control system, lighting, diagnostics system
<b>Voltage</b>	24 V
<b>Batteries</b>	2 x 135 Ah / 12 V
<b>Alternator</b>	Three-phase current 28 V / 140 A

Deviating parameters of the power supply system must always be clarified with Liebherr-Hydraulikbagger GmbH.



## Cooling system

<b>Diesel engine</b>	Water-cooled Cooling system, consisting of a cooling unit for water and charge air and a 2nd cooler for hydraulic oil, each with an infinitely variable, thermostatically controlled fan drive system
<b>Electric motor</b>	Air-cooled Cooling system for hydraulic oil with an infinitely variable, thermostatically controlled fan drive system



## Hydraulic controls

<b>Power distribution</b>	Via control valves with integrated safety valves, simultaneous actuation of chassis and equipment. Swing drive in separate closed circuit
<b>Servo circuit</b>	
<b>Equipment and swing</b>	With electro-hydraulic pilot control and proportional joystick levers
<b>Chassis mobile</b>	Electro-proportional via foot pedal
<b>Chassis crawler</b>	With electric proportionally functioning foot pedals or adjusted with plugable levers
<b>Additional functions</b>	Via switch or electro-proportional foot pedals
<b>Proportional control</b>	Proportionally acting transmitters on the joysticks for additional hydraulic functions



## Hydraulic system

<b>Hydraulic pump</b>	
<b>For equipment and travel drive</b>	2 Liebherr axial piston variable displacement pumps (double construction)
<b>Max. flow</b>	2 x 362 l/min.
<b>Max. pressure</b>	350 bar
<b>For swing drive</b>	Reversible axial piston variable displacement pump, closed-loop circuit
<b>Max. flow</b>	196 l/min.
<b>Max. pressure</b>	370 bar
<b>Hydraulic pump regulation and control</b>	2 circuit Liebherr-Synchron-Comfort-system (LSC) with electronic engine speed sensing regulation, pressure and flow compensation, automatic oil flow optimizer
<b>Hydraulic tank</b>	340 l
<b>Hydraulic system</b>	950 l
<b>Filtration</b>	2 main return filters with integrated partial micro filtration (5 µm)
<b>MODE selection</b>	Adjustment of engine and hydraulic performance via a mode pre-selector to match application, e.g. for especially economical and environmentally friendly operation or for maximum material handling and heavy-duty jobs
<b>S (Sensitive)</b>	Mode for precision work and lifting through very sensitive movements
<b>E (Eco)</b>	Mode for especially economical and environmentally friendly operation
<b>P (Power)</b>	Mode for high performance with low fuel consumption
<b>P+ (Power-Plus)</b>	Mode for highest performance and for very heavy duty applications, suitable for continuous operation
<b>Engine speed and performance setting</b>	Stepless alignment of engine output and hydraulic power via engine speed
<b>Option</b>	Tool Control: 20 pre-adjustable pump flows and pressures for add-on attachments



## Swing drive

<b>Drive</b>	Liebherr axial piston motor in a closed system, Liebherr planetary reduction gear
<b>Swing ring</b>	Liebherr, sealed race ball bearing swing ring, internal teeth
<b>Swing speed</b>	0-6.5 RPM stepless
<b>Swing torque</b>	141 kNm
<b>Holding brake</b>	Wet multi-disc (spring applied, pressure released)
<b>Option</b>	Slewing gear brake Comfort



## Cab

<b>Cab</b>	Safety cab structure with individual windscreens or featuring a slide-in subpart under the ceiling, work headlights integrated in the ceiling, a door with a sliding window (can be opened on both sides), large stowing and depositing possibilities, shock-absorbing suspension, sound damping insulating, tinted laminated safety glass, separate shades for the sunroof window and windscreen
High Rise / Gantry	Deviating from standard: safety cab structure with fixed built-in front and roof window made from impact-resistant laminated safety glass
<b>Operator's seat Comfort</b>	Air cushioned operator's seat with 3D-adjustable armrests, headrest, lap belt, seat heater, adjustable seat cushion inclination and length, lockable horizontal suspension, automatic weight adjustment, adjustable suspension stiffness, pneumatic lumbar vertebrae support and passive seat climatisation with active coal
<b>Operator's seat Premium (Option)</b>	In addition to operator's seat comfort: active electronic weight adjustment (automatic readjustment), pneumatic low frequency suspension and active seat climatisation with active coal and ventilator
<b>Arm consoles</b>	Joysticks with control consoles and swivel seat, folding left control console
<b>Operation and displays</b>	Large high-resolution operating unit, self-explanatory, colour display with touchscreen, video-compatible, numerous setting, control and monitoring options, e.g. air conditioning control, fuel consumption respectively energy consumption, machine and attachment parameters
<b>Air-conditioning</b>	
Diesel engine	Automatic air-conditioning, recirculated air function, fast de-icing and demisting at the press of a button, air vents can be operated via a menu; recirculated air and fresh air filters can be easily replaced and are accessible from the outside; heating-cooling unit, designed for extreme outside temperatures, sensors for solar radiation, inside and outside temperatures
Electric motor	In addition to diesel engine: stationary air conditioning function with external climate condenser - controlled by a weekly timer
Refrigerant	R134a
Global warming potential	1,430
Quantity at 25 °C*	1,400-2,000 g (Diesel) 1,600-2,200 g (Electric)
CO <sub>2</sub> equivalent*	2,002-2,860 t (Diesel) 2,288-3,146 t (Electric)
<b>Vibration emission**</b>	
Hand / arm vibrations	< 2.5 m/s <sup>2</sup>
Whole-body vibrations	< 0.5 m/s <sup>2</sup>
Measuring inaccuracy	According with standard EN 12096:1997



## Equipment

<b>Type</b>	High-strength steel plates at highly-stressed points for the toughest requirements. Complex and stable mountings of equipment and cylinders
<b>Hydraulic cylinders</b>	Liebherr cylinders with special sealing and guide system and, depending on cylinder type, shock absorption
<b>Energy recovering cylinder</b>	Liebherr gas cylinder with special sealing and control system
<b>Bearings</b>	Sealed, low maintenance

\* depending on configuration

\*\* for risk assessment according to 2002/44/EC see ISO/TR 25398:2006

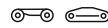

## Undercarriage

<b>Mobile</b>	
Versions	Standard, High Rise
Drive Standard	One axle drive per drive axle with Liebherr axial piston motor and functional brake valve on both sides
Drive High Rise	One driven axle with transmission with Liebherr axial piston motor and functional brake valve on both sides
Travel speed	0-10.0 km/h stepless
Joystick steering	0- 3.5 km/h stepless (creeper speed) (Diesel) 0- 3.1 km/h stepless (creeper speed) (Electric) 0- 8.0 km/h stepless (High Rise) 0- 5.0 km/h stepless (creeper speed) (High Rise) (Diesel) 0- 2.5 km/h stepless (creeper speed) (High Rise) (Electric)
Driving operation	Automotive driving using accelerator pedal, cruise control function: storage of variable accelerator pedal positions
Axles	90 t drive axles; manual or automatic hydraulically controlled front axle oscillation lock
Service brake	Two circuit travel brake system with accumulator; wet and backlash-free disc brake
Holding brake	Wet multi-disc (spring applied, pressure released)
Stabilization	4 point outriggers
<b>Crawler</b>	
Versions	EW, SW, High Rise, Gantry
Drive	Liebherr compact planetary reduction gear with Liebherr axial piston motor per side of undercarriage
Travel speed	
EW	0-4.0 km/h stepless 0-2.8 km/h stepless (creeper speed)
SW	0-4.1 km/h stepless 0-2.5 km/h stepless (creeper speed)
High Rise	0-2.9 km/h stepless 0-2.0 km/h stepless (creeper speed)
Gantry	0-3.6 km/h stepless 0-2.5 km/h stepless (creeper speed)
Brake	Functional brake valves on both sides
Holding brake	Wet multi-disc (spring applied, pressure released)
Track pads	Triple grouser, flat
Tracks	Sealed and greased



## Complete machine

<b>Lubrication</b>	Liebherr central lubrication system for uppercarriage and equipment, automatically
Mobile (Option)	Liebherr central lubrication system for undercarriage, automatically
<b>Steps system</b>	Safe and durable access system with anti-slip steps; main components hot-galvanised
<b>Noise emission</b>	
ISO 6396	70 dB(A) = L <sub>pA</sub> (inside cab)
2000/14/EC	105 dB(A) = L <sub>WA</sub> (surround noise)

# LH 80 M – Dimensions

## Industry

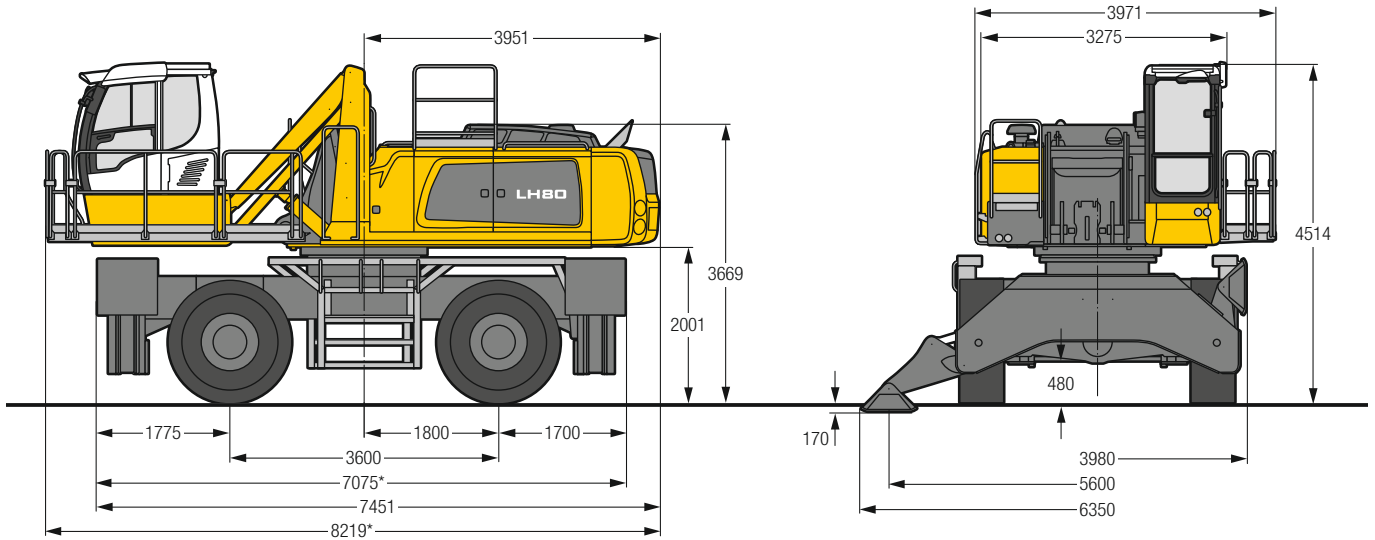

\* For electric machines, the length of the machine is increased accordingly by the trailing cable / cable reel system. Detailed dimensions are available on request.

# LH 80 M – Choice of cab elevation

## Cab elevation LFC (rigid elevation)

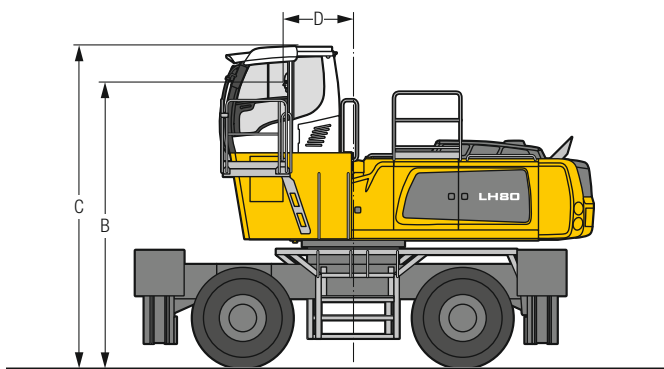

Increase type	LFC 120	LFC 200
Height	1,200 mm	2,000 mm
B	4,701 mm	5,501 mm
C	5,214 mm	6,014 mm
D	1,128 mm	1,128 mm

A rigid cab elevation has a fixed eye level height. For a lower transport height, the shell of the cab can be removed and replaced by a transport device. The dimension C is in this machine design for all rigid cab elevations 3,958 mm.

Tyres 23.5-25

## Cab elevation LHC (hydraulic elevation)

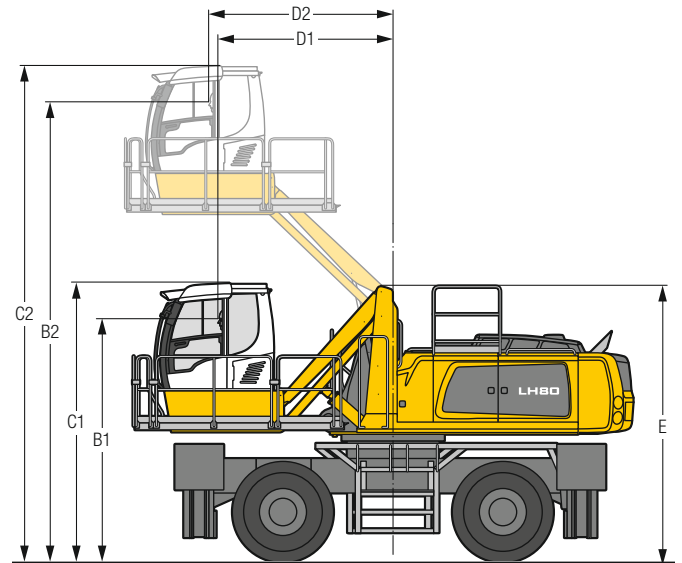

Increase type	LHC 255	LHC 340-35	LHC 360-50
B1	3,501 mm	3,852 mm	4,001 mm
B2	6,048 mm	7,267 mm	7,571 mm
C1	4,014 mm	4,366 mm	4,514 mm
C2	6,561 mm	7,780 mm	8,085 mm
D1	1,683 mm	2,796 mm	2,854 mm
D2	1,809 mm	2,797 mm	3,004 mm
E	3,916 mm	4,306 mm	4,456 mm

The hydraulically adjustable cab allows the driver, that he can choose his field of view freely and at any time within the stroke.

# LH 80 C EW / SW – Dimensions

Industry

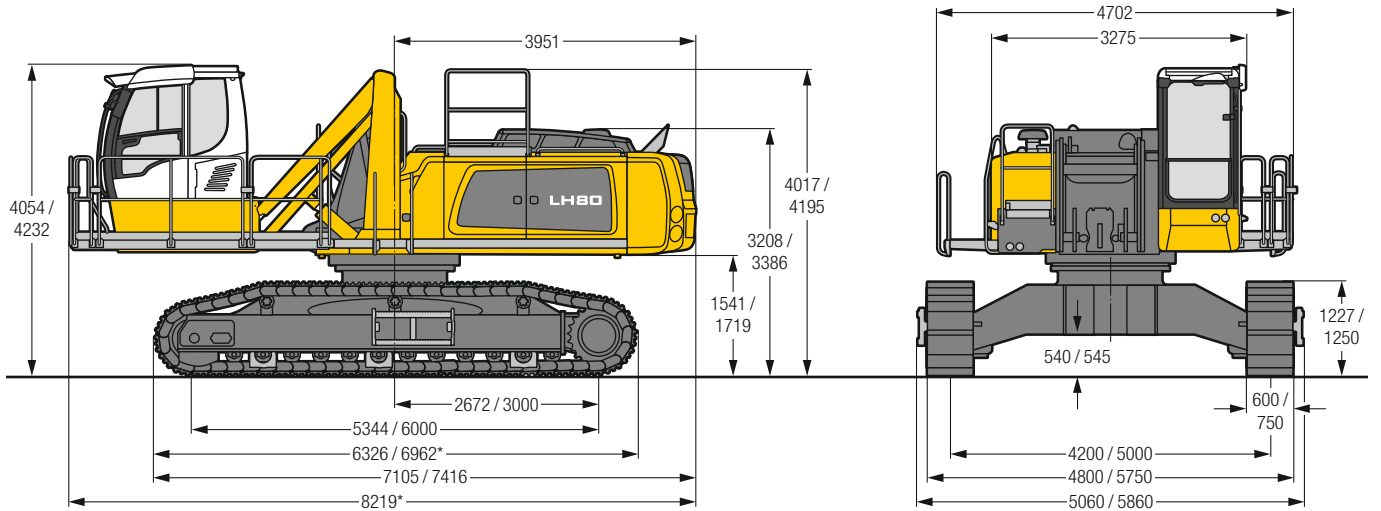

\* For electric machines, the length of the machine is increased accordingly by the trailing cable / cable reel system. Detailed dimensions are available on request.

# LH 80 C EW / SW – Choice of cab elevation

**Cab elevation LFC (rigid elevation)**

**Cab elevation LHC (hydraulic elevation)**

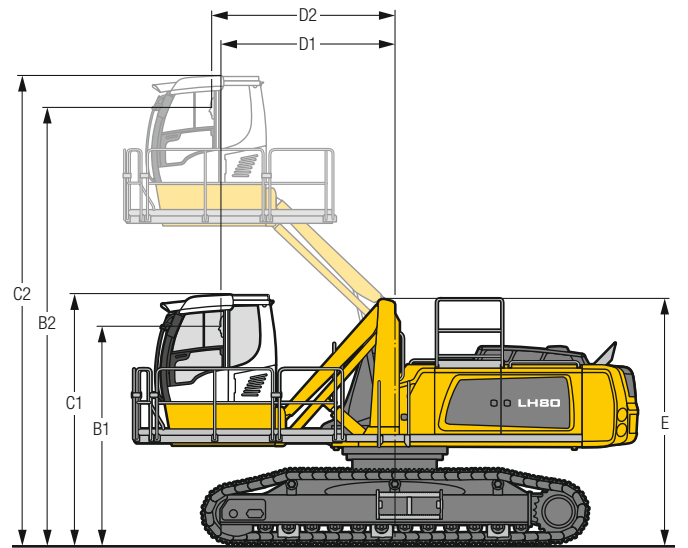
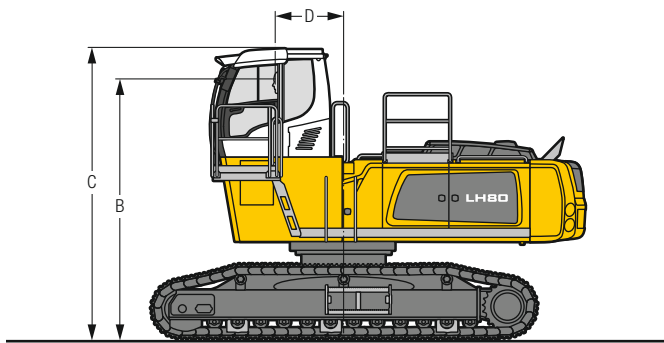

Increase type	LFC 120	LFC 200
Height	1,200 mm	2,000 mm
B	4,240 mm / 4,418 mm	5,040 mm / 5,218 mm
C	4,754 mm / 4,932 mm	5,554 mm / 5,732 mm
D	1,128 mm	1,128 mm

A rigid cab elevation has a fixed eye level height. For a lower transport height, the shell of the cab can be removed and replaced by a transport device. The dimension C is in this machine design for all rigid cab elevations 3,858 mm.

Increase type	LHC 255	LHC 340-35	LHC 360-50
B1	3,040 mm / 3,218 mm	3,392 mm / 3,570 mm	3,540 mm / 3,718 mm
B2	5,587 mm / 5,765 mm	6,807 mm / 6,985 mm	7,111 mm / 7,289 mm
C1	3,554 mm / 3,732 mm	3,905 mm / 4,083 mm	4,054 mm / 4,232 mm
C2	6,101 mm / 6,279 mm	7,320 mm / 7,498 mm	7,625 mm / 7,803 mm
D1	1,683 mm	2,796 mm	2,854 mm
D2	1,809 mm	2,797 mm	3,004 mm
E	3,456 mm / 3,634 mm	3,846 mm / 4,024 mm	3,996 mm / 4,173 mm

The hydraulically adjustable cab allows the driver, that he can choose his field of view freely and at any time within the stroke.

# LH 80 M HR – Dimensions

## Industry

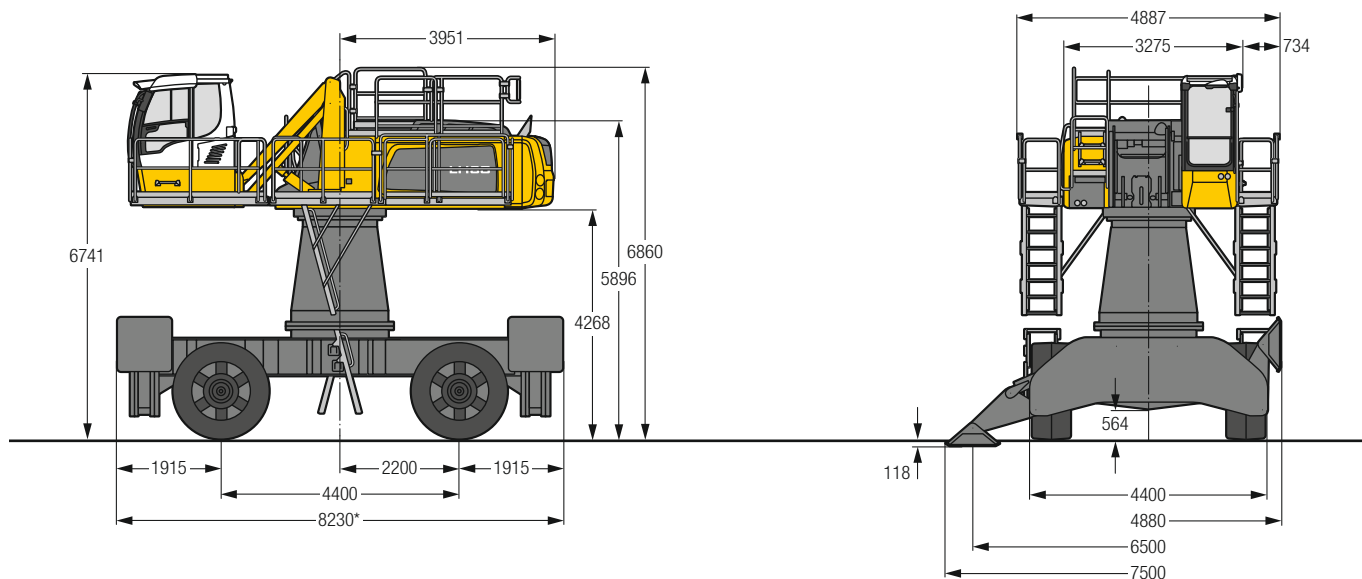

\* For electric machines, the length of the machine is increased accordingly by the trailing cable / cable reel system. Detailed dimensions are available on request.

# LH 80 M HR – Cab elevation

## Cab elevation LHC (hydraulic elevation)

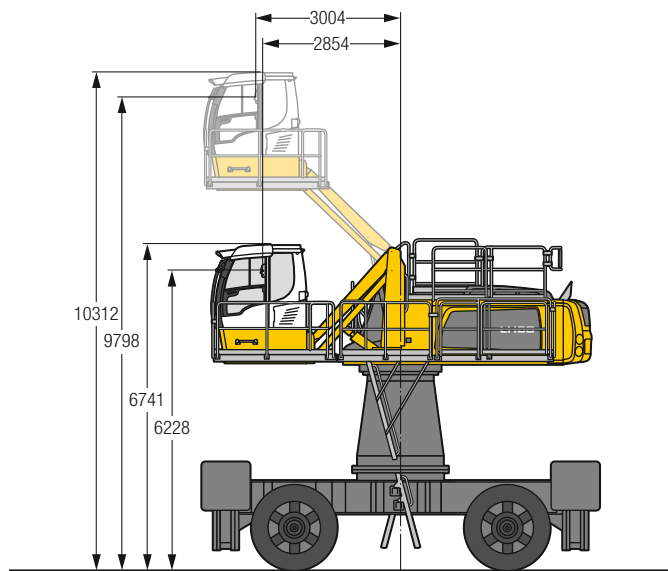

Increase type **LHC 360-50**

The hydraulically adjustable cab allows the driver, that he can choose his field of view freely and at any time within the stroke.

Tyres 26.5-25



# LH 80 C HR – Dimensions

Industry

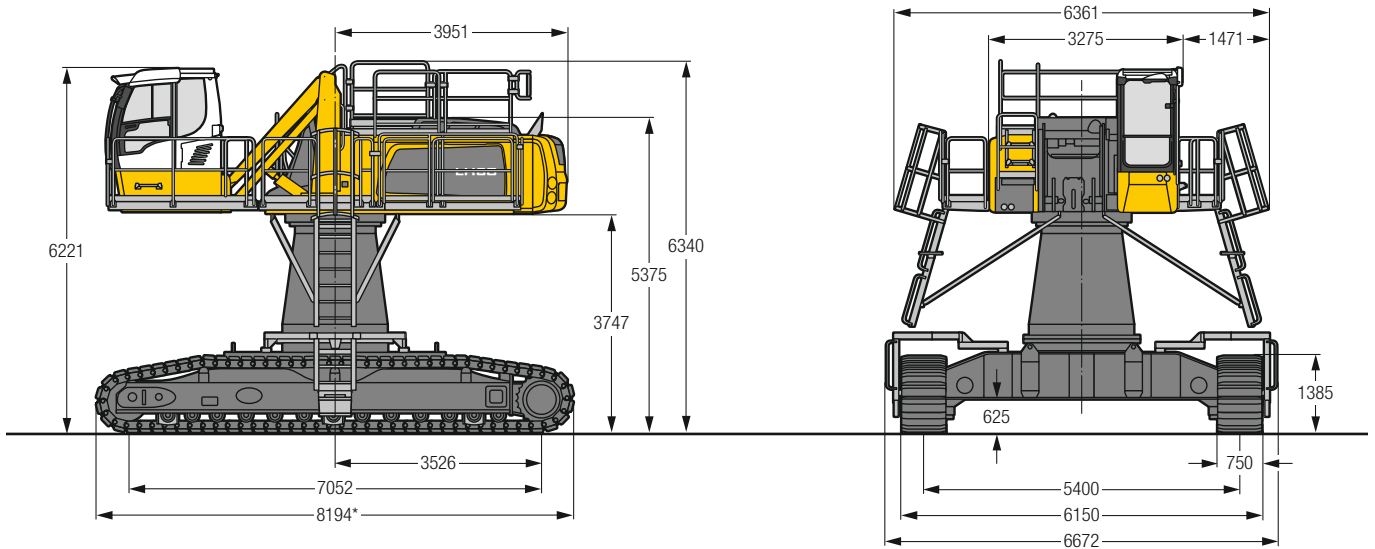

\* For electric machines, the length of the machine is increased accordingly by the trailing cable / cable reel system. Detailed dimensions are available on request.

# LH 80 C HR – Choice of cab elevation

**Cab elevation LHC**  
(hydraulic elevation)

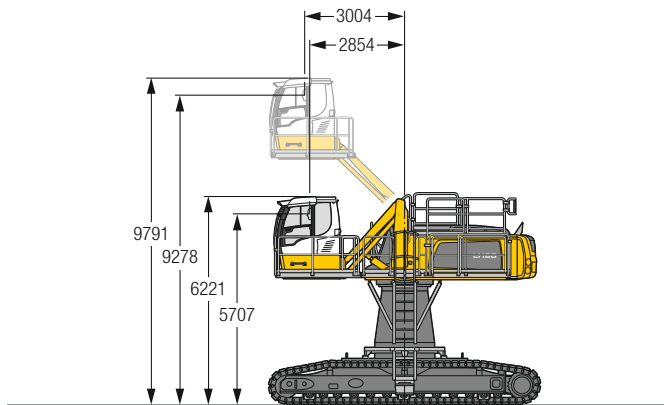

Increase type

LHC 360-50

The hydraulically adjustable cab allows the driver, that he can choose his field of view freely and at any time within the stroke.

**Cab elevation LHC-D**  
(hydraulic elevation)

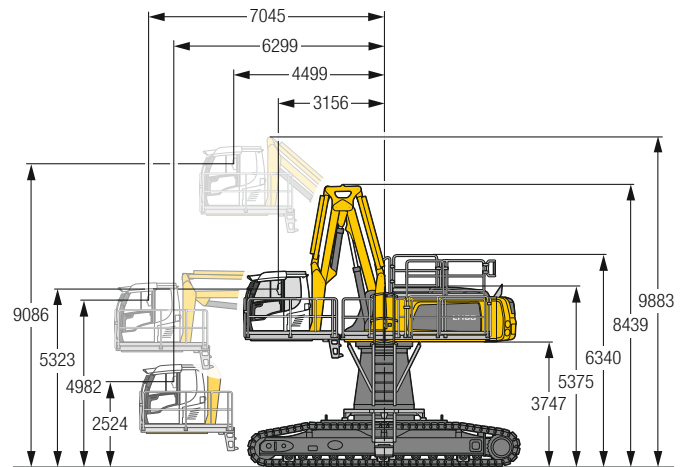

Increase type

LHC-D 730

The hydraulically adjustable cab allows the driver, that he can choose his field of view freely and at any time within the stroke.

# LH 80 C Gantry – Dimensions

Industry

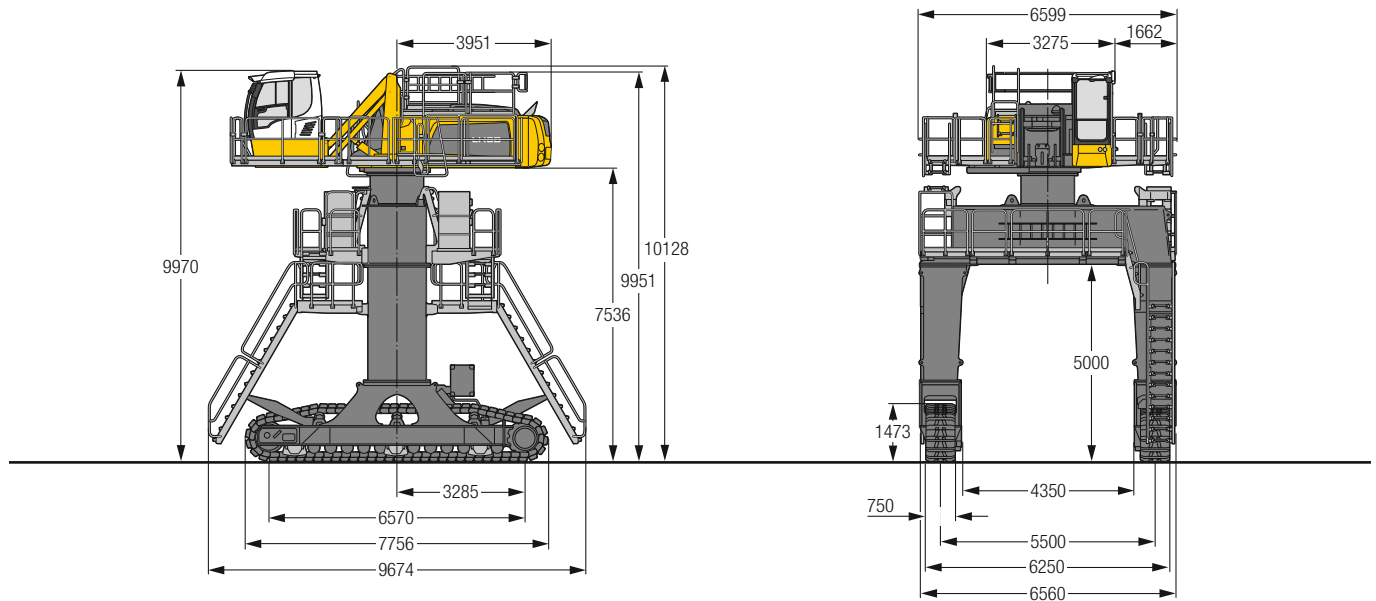

# LH 80 C Gantry – Cab elevation

**Cab elevation LHC  
(hydraulic elevation)**

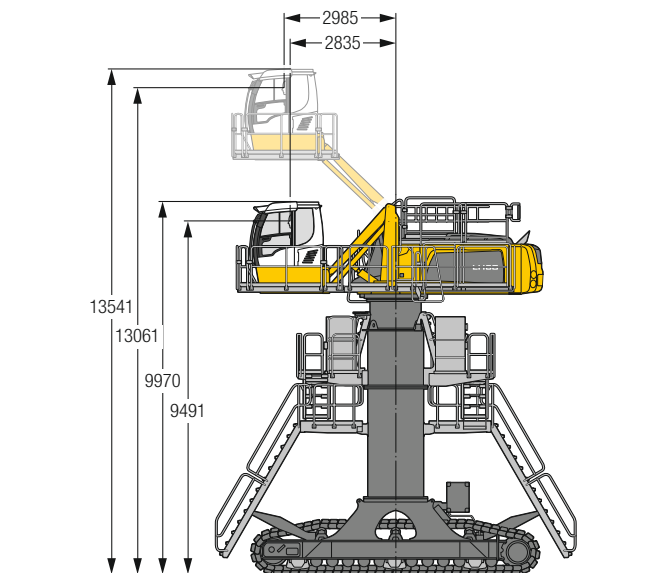

**Increase type** LHC 360-50

The hydraulically adjustable cab allows the driver, that he can choose his field of view freely and at any time within the stroke.

## Kinematic variant 2A

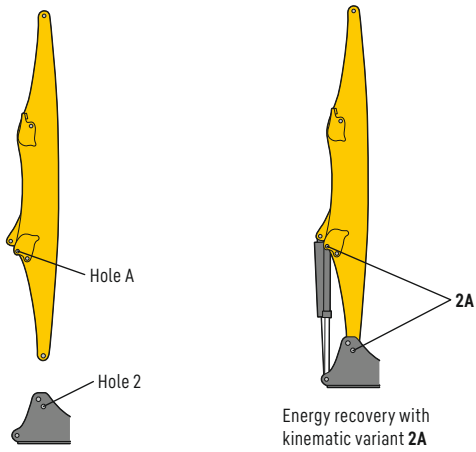

## Kinematic variant 2D / 2C

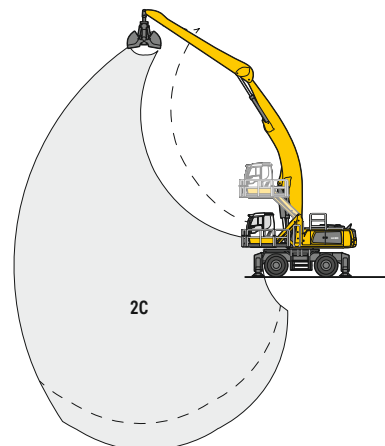
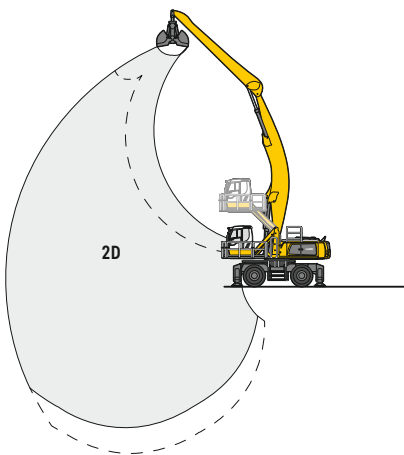
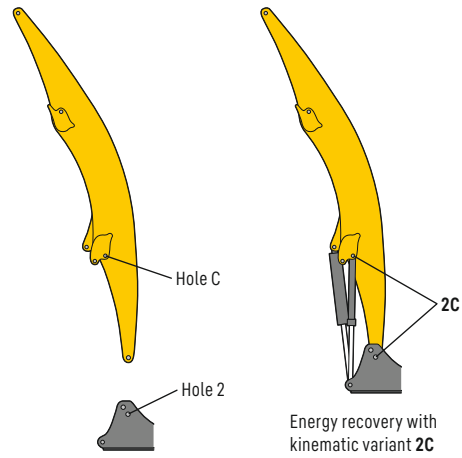
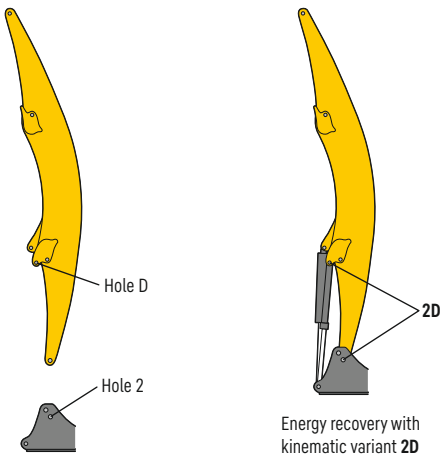

Altered range curve with additional reach depth, e.g. for unloading from ships

# LH 80 M – Equipment GA18

## Industry – Kinematic 2A

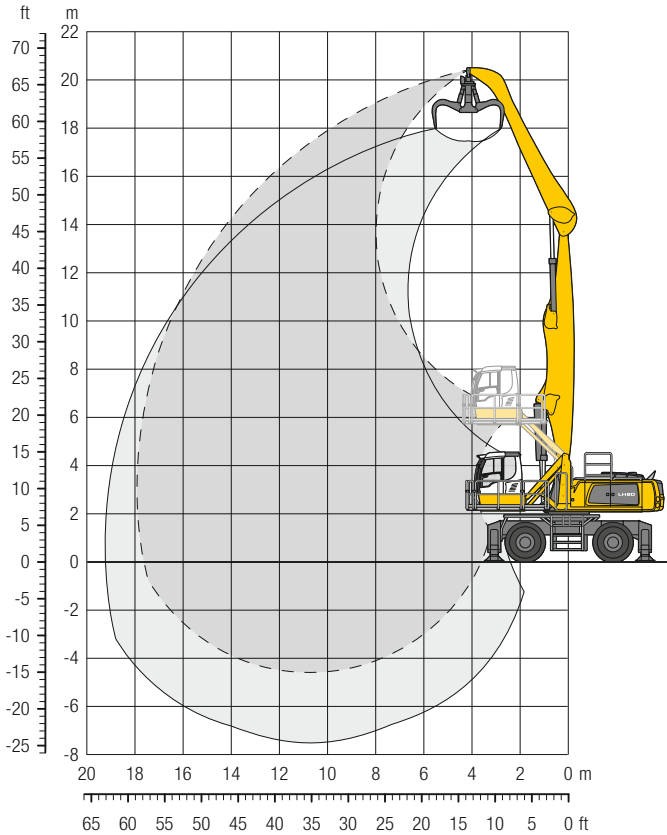

### Dimensions

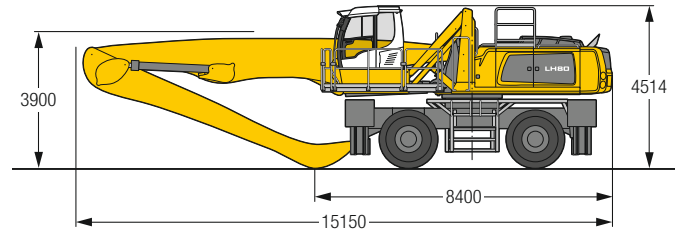

### Operating weight

The operating weight includes the basic machine with 4 point outriggers, hydr. cab elevation, 4 solid tyres, straight boom 10.50 m, angled stick 7.80 m and multi-tine grab GMM 80-5/1.70 m<sup>3</sup> semi-closed tines.

Weight 75,800 kg

m	Undercarriage	6.0 m		7.5 m		9.0 m		10.5 m		12.0 m		13.5 m		15.0 m		16.5 m		18.0 m		19.5 m		21.0 m		m					
		4 pt. outriggers down	4 pt. outriggers down	4 pt. outriggers down	4 pt. outriggers down	4 pt. outriggers down	4 pt. outriggers down	4 pt. outriggers down	4 pt. outriggers down	4 pt. outriggers down	4 pt. outriggers down	4 pt. outriggers down	4 pt. outriggers down	4 pt. outriggers down	4 pt. outriggers down	4 pt. outriggers down	4 pt. outriggers down	4 pt. outriggers down	4 pt. outriggers down	4 pt. outriggers down	4 pt. outriggers down	4 pt. outriggers down	4 pt. outriggers down						
22.5	4 pt. outriggers down																												
21.0	4 pt. outriggers down																												
19.5	4 pt. outriggers down	15.1*	15.1*																										
18.0	4 pt. outriggers down			14.8*	14.8*	12.6*	12.6*															12.9*	12.9*	7.1					
16.5	4 pt. outriggers down			15.7*	15.7*	14.4*	14.4*	12.5*	12.5*															9.5*	9.5*	11.9			
15.0	4 pt. outriggers down					15.4*	15.4*	13.8*	13.8*	12.2*	12.2*														8.8*	8.8*	13.4		
13.5	4 pt. outriggers down							15.3*	15.3*	13.7*	13.7*	11.4*	11.4*													8.4*	8.4*	14.6	
12.0	4 pt. outriggers down							15.4*	15.4*	13.8*	13.8*	12.5*	12.5*	11.5*	11.5*	10.1*	10.1*										8.1*	8.1*	15.6
10.5	4 pt. outriggers down					17.3*	17.3*	15.7*	15.7*	13.9*	13.9*	12.6*	12.6*	11.5*	11.5*	10.6*	10.6*										7.9*	7.9*	16.3
9.0	4 pt. outriggers down					18.6*	18.6*	16.1*	16.1*	14.2*	14.2*	12.8*	12.8*	11.6*	11.6*	10.7*	10.7*	9.7*	9.7*								7.9*	7.9*	16.9
7.5	4 pt. outriggers down	19.5*	19.5*	19.5*	19.5*	16.7*	16.7*	14.6*	14.6*	13.1*	13.1*	11.8*	11.8*	10.8*	10.8*	9.6*	9.6*	9.7*	9.7*								7.9*	7.9*	17.4
6.0	4 pt. outriggers down	25.5*	25.5*	20.6*	20.6*	17.4*	17.4*	15.1*	15.1*	13.3*	13.3*	12.0*	12.0*	10.8*	10.8*	9.5*	9.5*	9.8*	9.8*								7.9*	7.9*	17.7
4.5	4 pt. outriggers down	27.5*	27.5*	21.8*	21.8*	18.1*	18.1*	15.5*	15.5*	13.6*	13.6*	12.1*	12.1*	10.9*	10.9*	9.3*	9.3*	9.7*	9.7*								8.1*	8.1*	17.9
3.0	4 pt. outriggers down	20.0*	20.0*	22.7*	22.7*	18.7*	18.7*	15.9*	15.9*	13.8*	13.8*	12.2*	12.2*	10.7*	10.8*	9.2*	9.6*										8.1*	8.1*	17.9
1.5	4 pt. outriggers down	10.5*	10.5*	23.2*	23.2*	19.0*	19.0*	16.1*	16.1*	13.9*	13.9*	12.2*	12.2*	10.4*	10.7*	9.1*	9.2*										7.6*	7.6*	17.8
0	4 pt. outriggers down	9.0*	9.0*	20.9*	20.9*	18.8*	18.8*	15.9*	15.9*	13.7*	13.7*	11.9*	11.9*	10.3*	10.3*	8.6*	8.6*										7.0*	7.0*	17.6
-1.5	4 pt. outriggers down	9.4*	9.4*	17.8*	17.8*	18.0*	18.0*	15.3*	15.3*	13.1*	13.1*	11.2*	11.2*	9.5*	9.5*	7.6*	7.6*										6.8*	6.8*	16.9
-3.0	4 pt. outriggers down			17.4*	17.4*	16.3*	16.3*	14.0*	14.0*	11.9*	11.9*	10.1*	10.1*	8.2*	8.2*												7.6*	7.6*	15.4
-4.5	4 pt. outriggers down							11.9*	11.9*																		10.2*	10.2*	11.8

Height Can be slewed through 360° In longitudinal position of undercarriage Max. reach \* Limited by hydr. capacity

The lift capacities on the stick end without attachment are stated in metric tons (t) and are valid on a firm, level supporting surface with blocked oscillating axle. These capacities can be slewed through 360° with the undercarriage in the transverse position. Capacities in the longitudinal position of the undercarriage (±15°) are specified over the rigid axle with the stabilizers down. Indicated loads based on the ISO 10567 standard and do not exceed 75% of tipping or 87% of hydraulic capacity. The lift capacity values indicated are attained at the corresponding operating temperature. This operating temperature is ensured by continuous movement of the boom. Weights of fitted attachments (grabs, load hooks, etc.) and load accommodation attachment are to be deducted from the lift capacity values. The lift capacity of the unit is limited by its stability, the lifting capability of the hydraulic elements, or the maximum permissible lifting capacity of the load hook. In accordance with the harmonised European Standard EN 474-5, hydraulic excavators used for lifting operations must be equipped with pipe fracture safety valves, an overload warning device, a load hook and a lift capacity chart.

# LH 80 M – Equipment GA20

## Industry – Kinematic 2A

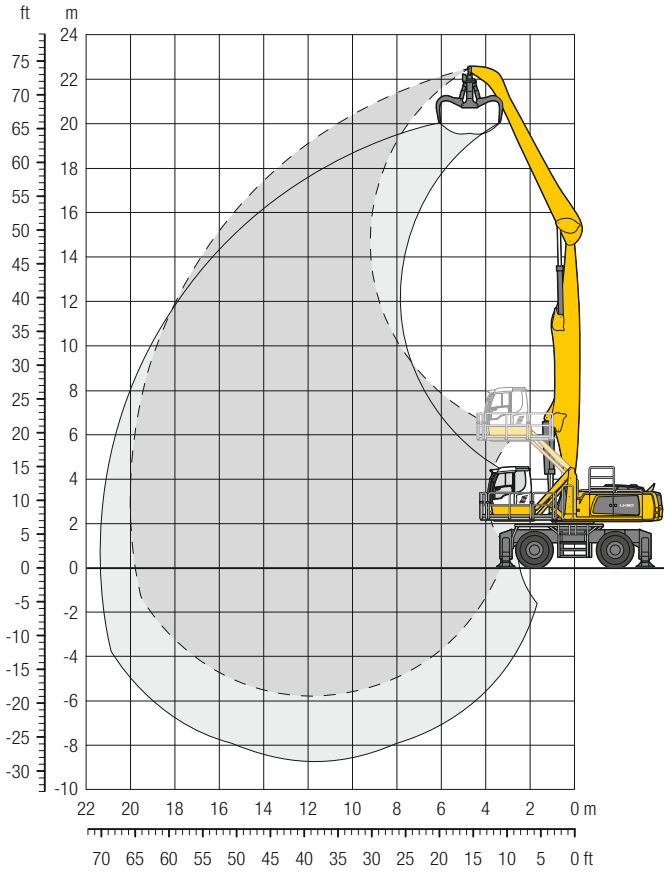

### Dimensions

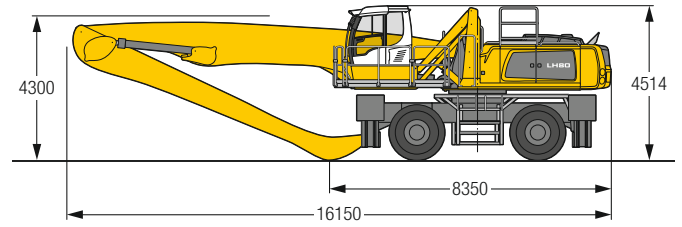

### Operating weight

The operating weight includes the basic machine with 4 point outriggers, hydr. cab elevation, 4 solid tyres, straight boom 11.50 m, angled stick 9.00 m and multi-tine grab GMM 80-5/1.70 m<sup>3</sup> semi-closed tines.

Weight 76,800 kg

m	Undercarriage	6.0 m		7.5 m		9.0 m		10.5 m		12.0 m		13.5 m		15.0 m		16.5 m		18.0 m		19.5 m		21.0 m		m	
		☞	☞	☞	☞	☞	☞	☞	☞	☞	☞	☞	☞	☞	☞	☞	☞	☞	☞	☞	☞	☞	☞	☞	☞
22.5	4 pt. outriggers down																						14.5*	14.5*	4.7
21.0	4 pt. outriggers down			12.5*	12.5*																		10.3*	10.3*	8.9
19.5	4 pt. outriggers down					12.3*	12.3*	10.6*	10.6*														8.8*	8.8*	11.5
18.0	4 pt. outriggers down					13.1*	13.1*			10.4*	10.4*												7.9*	7.9*	13.4
16.5	4 pt. outriggers down							12.8*	12.8*	11.6*	11.6*	10.1*	10.1*										7.4*	7.4*	14.9
15.0	4 pt. outriggers down							12.7*	12.7*	11.5*	11.5*	10.5*	10.5*	9.5*	9.5*								7.0*	7.0*	16.2
13.5	4 pt. outriggers down							12.7*	12.7*	11.5*	11.5*	10.4*	10.4*	9.6*	9.6*	8.5*	8.5*						6.8*	6.8*	17.2
12.0	4 pt. outriggers down					14.4*	14.4*	12.8*	12.8*	11.5*	11.5*	10.5*	10.5*	9.6*	9.6*	8.9*	8.9*						6.6*	6.6*	18.0
10.5	4 pt. outriggers down					14.8*	14.8*	13.0*	13.0*	11.7*	11.7*	10.6*	10.6*	9.6*	9.6*	8.9*	8.9*	8.2*	8.2*				6.6*	6.6*	18.7
9.0	4 pt. outriggers down					15.2*	15.2*	13.3*	13.3*	11.9*	11.9*	10.7*	10.7*	9.7*	9.7*	8.9*	8.9*	8.2*	8.2*				6.5*	6.5*	19.2
7.5	4 pt. outriggers down	15.0*	15.0*	17.6*	17.6*	15.8*	15.8*	13.7*	13.7*	12.1*	12.1*	10.8*	10.8*	9.8*	9.8*	9.0*	9.0*	8.1*	8.2*	6.8*	6.8*		6.5*	6.5*	19.6
6.0	4 pt. outriggers down	22.4*	22.4*	19.5*	19.5*	16.3*	16.3*	14.1*	14.1*	12.4*	12.4*	11.0*	11.0*	9.9*	9.9*	9.0*	9.0*	8.0*	8.2*	6.8*	7.3*		6.6*	6.6*	19.8
4.5	4 pt. outriggers down	25.9*	25.9*	20.5*	20.5*	16.9*	16.9*	14.5*	14.5*	12.6*	12.6*	11.2*	11.2*	10.0*	10.0*	9.0*	9.0*	7.8*	8.1*	6.8*	7.1*		6.4*	6.7*	20.0
3.0	4 pt. outriggers down	15.4*	15.4*	21.3*	21.3*	17.4*	17.4*	14.8*	14.8*	12.8*	12.8*	11.3*	11.3*	10.0*	10.0*	8.8*	9.0*	7.6*	8.0*	6.7*	6.9*		6.4*	6.4*	20.0
1.5	4 pt. outriggers down	7.7*	7.7*	21.6*	21.6*	17.7*	17.7*	14.9*	14.9*	12.9*	12.9*	11.3*	11.3*	10.0*	10.0*	8.6*	8.9*	7.5*	7.8*	6.5*	6.5*		6.0*	6.0*	20.0
0	4 pt. outriggers down	6.5*	6.5*	14.7*	14.7*	17.6*	17.6*	14.9*	14.9*	12.8*	12.8*	11.2*	11.2*	9.7*	9.8*	8.4*	8.6*	7.4*	7.4*	5.9*	5.9*		5.5*	5.5*	19.8
-1.5	4 pt. outriggers down	6.7*	6.7*	12.6*	12.6*	17.0*	17.0*	14.4*	14.4*	12.4*	12.4*	10.8*	10.8*	9.4*	9.4*	8.1*	8.1*	6.8*	6.8*				5.0*	5.0*	19.4
-3.0	4 pt. outriggers down	7.5*	7.5*	12.3*	12.3*	15.8*	15.8*	13.5*	13.5*	11.7*	11.7*	10.1*	10.1*	8.7*	8.7*	7.3*	7.3*	5.7*	5.7*				5.4*	5.4*	18.2
-4.5	4 pt. outriggers down			12.7*	12.7*	13.8*	13.8*	12.1*	12.1*	10.4*	10.4*	9.0*	9.0*	7.5*	7.5*								6.2*	6.2*	16.4

☞ Height ☞ Can be slewed through 360° ☞ In longitudinal position of undercarriage ☞ Max. reach \* Limited by hydr. capacity

The lift capacities on the stick end without attachment are stated in metric tons (t) and are valid on a firm, level supporting surface with blocked oscillating axle. These capacities can be slewed through 360° with the undercarriage in the transverse position. Capacities in the longitudinal position of the undercarriage (±15°) are specified over the rigid axle with the stabilizers down. Indicated loads based on the ISO 10567 standard and do not exceed 75% of tipping or 87% of hydraulic capacity. The lift capacity values indicated are attained at the corresponding operating temperature. This operating temperature is ensured by continuous movement of the boom. Weights of fitted attachments (grabs, load hooks, etc.) and load accommodation attachment are to be deducted from the lift capacity values. The lift capacity of the unit is limited by its stability, the lifting capability of the hydraulic elements, or the maximum permissible lifting capacity of the load hook. In accordance with the harmonised European Standard EN 474-5, hydraulic excavators used for lifting operations must be equipped with pipe fracture safety valves, an overload warning device, a load hook and a lift capacity chart.

# LH 80 M – Equipment GA21

## Industry – Kinematic 2A

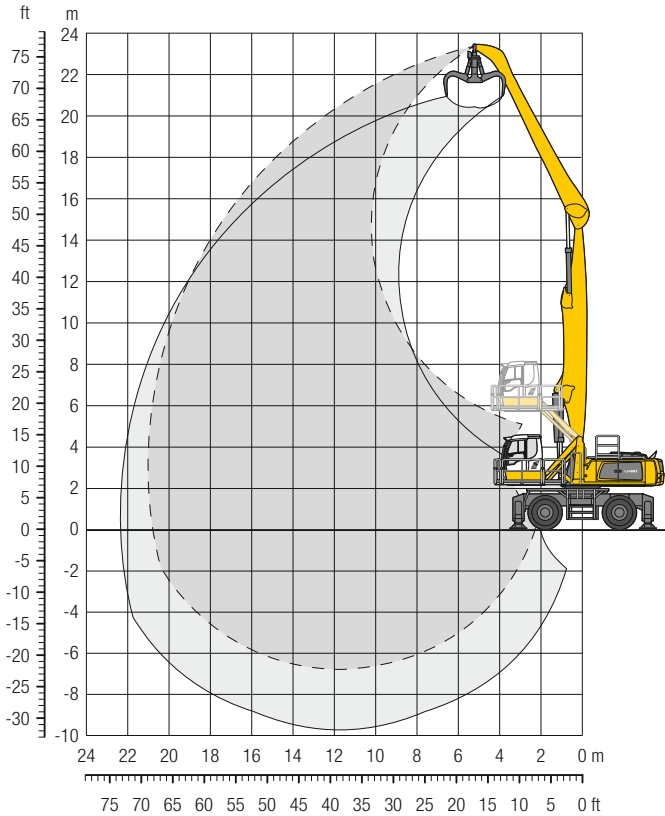

### Dimensions

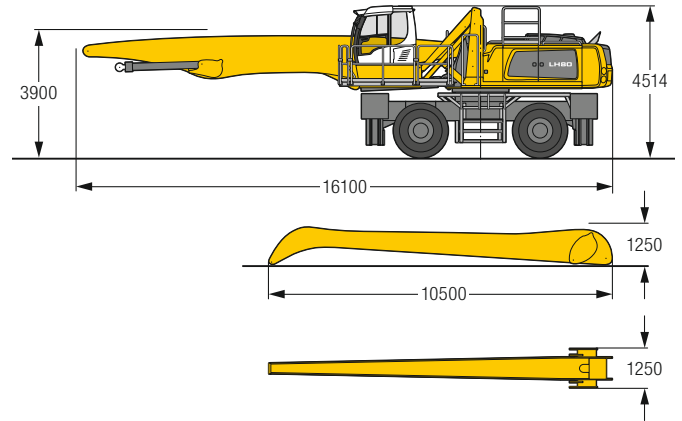

### Operating weight

The operating weight includes the basic machine with 4 point outriggers, hydr. cab elevation, 4 solid tyres, straight boom 11.50 m, angled stick 10.00 m and multi-tine grab GMM 80-5 / 140 m<sup>3</sup> semi-closed tines.

Weight 77,200 kg

m	Undercarriage	6.0 m		7.5 m		9.0 m		10.5 m		12.0 m		13.5 m		15.0 m		16.5 m		18.0 m		19.5 m		21.0 m		m																
		Icon	Icon	Icon	Icon	Icon	Icon	Icon	Icon	Icon	Icon	Icon	Icon	Icon	Icon	Icon	Icon	Icon	Icon	Icon	Icon	Icon	Icon																	
24.0	4 pt. outriggers down																																							
22.5	4 pt. outriggers down			10.9*	10.9*																		10.2*	10.2*	7.9															
21.0	4 pt. outriggers down					10.9*	10.9*	9.1*	9.1*																8.3*	8.3*	11.0													
19.5	4 pt. outriggers down					11.8*	11.8*	10.7*	10.7*	9.2*	9.2*																7.4*	7.4*	13.1											
18.0	4 pt. outriggers down							11.4*	11.4*	10.4*	10.4*	8.9*	8.9*																6.8*	6.8*	14.8									
16.5	4 pt. outriggers down							11.8*	11.8*	11.1*	11.1*	10.1*	10.1*	8.5*	8.5*															6.4*	6.4*	16.2								
15.0	4 pt. outriggers down							12.1*	12.1*	11.0*	11.0*	10.0*	10.0*	9.2*	9.2*	7.8*	7.8*														6.1*	6.1*	17.3							
13.5	4 pt. outriggers down							12.2*	12.2*	11.0*	11.0*	10.0*	10.0*	9.2*	9.2*	8.5*	8.5*	6.6*	6.6*													5.9*	5.9*	18.3						
12.0	4 pt. outriggers down							12.3*	12.3*	11.1*	11.1*	10.1*	10.1*	9.2*	9.2*	8.5*	8.5*	7.9*	7.9*														5.8*	5.8*	19.1					
10.5	4 pt. outriggers down							12.5*	12.5*	11.2*	11.2*	10.1*	10.1*	9.3*	9.3*	8.5*	8.5*	7.9*	7.9*	6.2*	6.2*												5.7*	5.7*	19.7					
9.0	4 pt. outriggers down					13.5*	13.5*	12.8*	12.8*	11.4*	11.4*	10.3*	10.3*	9.4*	9.4*	8.6*	8.6*	7.9*	7.9*	7.1*	7.3*												5.7*	5.7*	20.2					
7.5	4 pt. outriggers down					13.4*	13.4*	15.0*	15.0*	13.1*	13.1*	11.6*	11.6*	10.4*	10.4*	9.5*	9.5*	8.6*	8.6*	7.9*	7.9*	7.0*	7.2*											5.7*	5.7*	20.6				
6.0	4 pt. outriggers down	13.8*	13.8*	16.7*	16.7*	15.7*	15.7*	13.5*	13.5*	11.9*	11.9*	10.6*	10.6*	9.6*	9.6*	8.7*	8.7*	7.9*	7.9*	6.9*	7.2*														5.7*	5.7*	20.8			
4.5	4 pt. outriggers down	24.6*	24.6*	19.6*	19.6*	16.3*	16.3*	13.9*	13.9*	12.2*	12.2*	10.8*	10.8*	9.7*	9.7*	8.8*	8.8*	7.8*	7.9*	6.8*	7.1*															5.8*	5.8*	21.0		
3.0	4 pt. outriggers down	26.1*	26.1*	20.5*	20.5*	16.8*	16.8*	14.3*	14.3*	12.4*	12.4*	11.0*	11.0*	9.8*	9.8*	8.8*	8.8*	7.6*	7.9*	6.6*	7.0*	5.8	5.9*													5.8	5.9*	21.0		
1.5	4 pt. outriggers down	12.0*	12.0*	21.1*	21.1*	17.2*	17.2*	14.6*	14.6*	12.6*	12.6*	11.0*	11.0*	9.8*	9.8*	8.6*	8.7*	7.4*	7.8*	6.5*	6.8*															5.5*	5.5*	20.9		
0	4 pt. outriggers down	7.9*	7.9*	19.7*	19.7*	17.4*	17.4*	14.6*	14.6*	12.6*	12.6*	11.0*	11.0*	9.7*	9.7*	8.4*	8.6*	7.3*	7.5*	6.4*	6.4*																5.1*	5.1*	20.8	
-1.5	4 pt. outriggers down	7.2*	7.2*	14.3*	14.3*	17.1*	17.1*	14.4*	14.4*	12.4*	12.4*	10.8*	10.8*	9.4*	9.4*	8.2*	8.3*	7.1*	7.1*	5.8*	5.8*																4.6*	4.6*	20.5	
-3.0	4 pt. outriggers down	7.5*	7.5*	12.8*	12.8*	16.3*	16.3*	13.9*	13.9*	11.9*	11.9*	10.3*	10.3*	8.9*	8.9*	7.7*	7.7*	6.4*	6.4*	4.8*	4.8*																	4.7*	4.7*	19.6
-4.5	4 pt. outriggers down	8.2*	8.2*	12.7*	12.7*	14.9*	14.9*	12.8*	12.8*	11.0*	11.0*	9.5*	9.5*	8.1*	8.1*	6.8*	6.8*	5.3*	5.3*																			5.2*	5.2*	18.1
-6.0	4 pt. outriggers down					12.7*	12.7*	11.1*	11.1*	9.6*	9.6*	8.2*	8.2*	6.8*	6.8*																							6.3*	6.3*	15.6

Height Can be slewed through 360° In longitudinal position of undercarriage Max. reach \* Limited by hydr. capacity

The lift capacities on the stick end without attachment are stated in metric tons (t) and are valid on a firm, level supporting surface with blocked oscillating axle. These capacities can be slewed through 360° with the undercarriage in the transverse position. Capacities in the longitudinal position of the undercarriage (±15°) are specified over the rigid axle with the stabilizers down. Indicated loads based on the ISO 10567 standard and do not exceed 75% of tipping or 87% of hydraulic capacity. The lift capacity values indicated are attained at the corresponding operating temperature. This operating temperature is ensured by continuous movement of the boom. Weights of fitted attachments (grabs, load hooks, etc.) and load accommodation attachment are to be deducted from the lift capacity values. The lift capacity of the unit is limited by its stability, the lifting capability of the hydraulic elements, or the maximum permissible lifting capacity of the load hook. In accordance with the harmonised European Standard EN 474-5, hydraulic excavators used for lifting operations must be equipped with pipe fracture safety valves, an overload warning device, a load hook and a lift capacity chart.

# LH 80 M – Equipment GA22

## Industry – Kinematic 2A

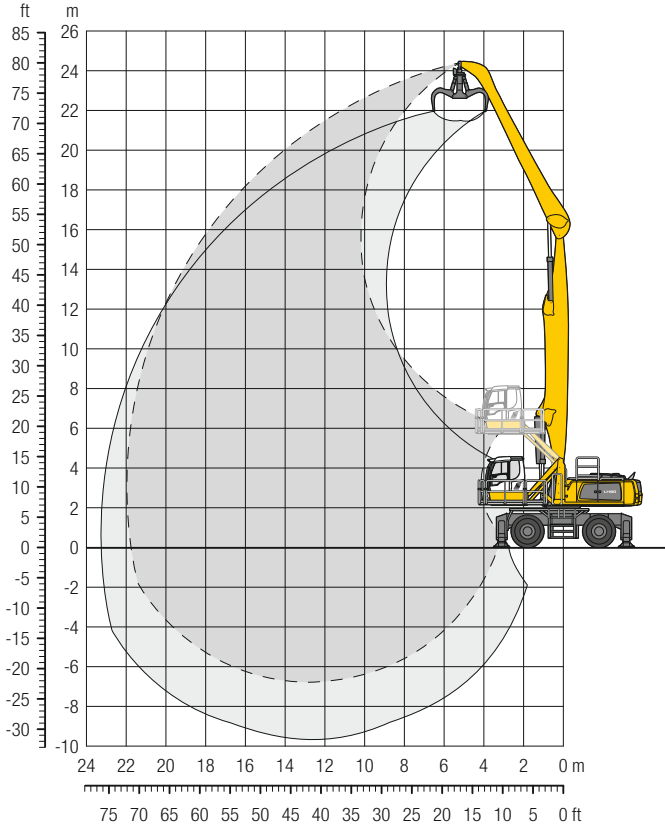

### Dimensions

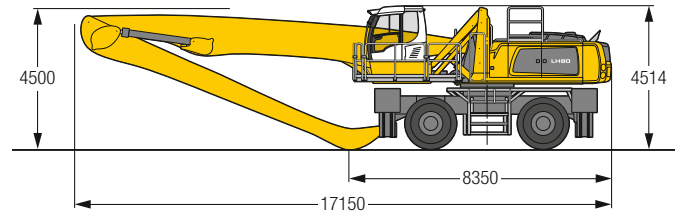

### Operating weight

The operating weight includes the basic machine with 4 point outriggers, hydr. cab elevation, 4 solid tyres, straight boom 12.50m, angled stick 10.00m and multi-tine grab GMM 80-5 /1.40 m<sup>3</sup> semi-closed tines.

Weight	78,000 kg
--------	-----------

m	Undercarriage	6.0 m		7.5 m		9.0 m		10.5 m		12.0 m		13.5 m		15.0 m		16.5 m		18.0 m		19.5 m		21.0 m		m		
		Can be slewed through 360°	In longitudinal position of undercarriage	Can be slewed through 360°	In longitudinal position of undercarriage	Can be slewed through 360°	In longitudinal position of undercarriage	Can be slewed through 360°	In longitudinal position of undercarriage	Can be slewed through 360°	In longitudinal position of undercarriage	Can be slewed through 360°	In longitudinal position of undercarriage	Can be slewed through 360°	In longitudinal position of undercarriage	Can be slewed through 360°	In longitudinal position of undercarriage	Can be slewed through 360°	In longitudinal position of undercarriage	Can be slewed through 360°	In longitudinal position of undercarriage	Can be slewed through 360°	In longitudinal position of undercarriage	Can be slewed through 360°	In longitudinal position of undercarriage	
24.0	4 pt. outriggers down	12.3*	12.3*																					11.5*	11.5*	6.6
22.5	4 pt. outriggers down																							8.8*	8.8*	10.3
21.0	4 pt. outriggers down			10.5*	10.5*																			7.7*	7.7*	12.7
19.5	4 pt. outriggers down			11.6*	11.6*	10.4*	10.4*	8.8*	8.8*															7.0*	7.0*	14.6
18.0	4 pt. outriggers down					11.3*	11.3*	10.3*	10.3*	8.8*	8.8*													6.5*	6.5*	16.2
16.5	4 pt. outriggers down					12.1*	12.1*	10.8*	10.8*	9.8*	9.8*	8.5*	8.5*											6.2*	6.2*	17.4
15.0	4 pt. outriggers down					12.2*	12.2*	10.8*	10.8*	9.7*	9.7*	8.8*	8.8*	8.1*	8.1*	7.1*	7.1*							6.0*	6.0*	18.5
13.5	4 pt. outriggers down					12.2*	12.2*	10.8*	10.8*	9.7*	9.7*	8.8*	8.8*	8.1*	8.1*	7.4*	7.4*							5.8*	5.8*	19.4
12.0	4 pt. outriggers down					12.3*	12.3*	10.9*	10.9*	9.8*	9.8*	8.9*	8.9*	8.1*	8.1*	7.4*	7.4*							6.8*	6.8*	20.1
10.5	4 pt. outriggers down					13.2*	13.2*	12.5*	12.5*	11.0*	11.0*	9.9*	9.9*	8.9*	8.9*	8.1*	8.1*	7.4*	7.4*					5.7*	5.7*	20.7
9.0	4 pt. outriggers down					14.3*	14.3*	12.7*	12.7*	11.2*	11.2*	10.0*	10.0*	9.0*	9.0*	8.1*	8.1*	7.4*	7.4*					5.8	6.1*	21.2
7.5	4 pt. outriggers down	12.4*	12.4*	15.0*	15.0*	15.1*	15.1*	13.0*	13.0*	11.3*	11.3*	10.1*	10.1*	9.0*	9.0*	8.2*	8.2*	7.4*	7.4*					5.4	5.7*	21.6
6.0	4 pt. outriggers down	19.1*	19.1*	18.7*	18.7*	15.5*	15.5*	13.2*	13.2*	11.5*	11.5*	10.2*	10.2*	9.1*	9.1*	8.2*	8.2*	7.5*	7.5*	6.6	6.7*	5.7	6.0*	5.3	5.5*	21.8
4.5	4 pt. outriggers down	24.7*	24.7*	19.4*	19.4*	15.9*	15.9*	13.5*	13.5*	11.7*	11.7*	10.3*	10.3*	9.2*	9.2*	8.2*	8.2*	7.4*	7.4*	6.5	6.7*	5.6	5.9*	5.1	5.3*	21.9
3.0	4 pt. outriggers down	10.5*	10.5*	19.9*	19.9*	16.2*	16.2*	13.7*	13.7*	11.8*	11.8*	10.4*	10.4*	9.2*	9.2*	8.2*	8.2*	7.3	7.4*	6.3	6.6*	5.5	5.7*	5.0*	5.0*	22.0
1.5	4 pt. outriggers down	5.4*	5.4*	15.8*	15.8*	16.4*	16.4*	13.8*	13.8*	11.9*	11.9*	10.4*	10.4*	9.2*	9.2*	8.1	8.1*	7.0	7.2*	6.1	6.4*	5.4	5.5*	4.7*	4.7*	21.9
0	4 pt. outriggers down	4.6*	4.6*	10.4*	10.4*	16.2*	16.2*	13.7*	13.7*	11.8*	11.8*	10.3*	10.3*	9.0*	9.0*	7.8	8.0*	6.8	7.0*	6.0	6.1*	5.0*	5.0*	4.3*	4.3*	21.7
-1.5	4 pt. outriggers down	4.9*	4.9*	9.1*	9.1*	15.7*	15.7*	13.3*	13.3*	11.5*	11.5*	10.0*	10.0*	8.7*	8.7*	7.6	7.7*	6.7*	6.7*	5.6*	5.6*	4.4*	4.4*	3.8*	3.8*	21.5
-3.0	4 pt. outriggers down	5.5*	5.5*	9.0*	9.0*	14.6*	14.6*	12.6*	12.6*	10.9*	10.9*	9.5*	9.5*	8.2*	8.2*	7.1*	7.1*	6.1*	6.1*	4.9*	4.9*			3.9*	3.9*	20.6
-4.5	4 pt. outriggers down			9.4*	9.4*	13.0*	13.0*	11.4*	11.4*	9.9*	9.9*	8.6*	8.6*	7.5*	7.5*	6.4*	6.4*	5.2*	5.2*					4.3*	4.3*	19.1
-6.0	4 pt. outriggers down			10.8*	10.8*	9.7*	9.7*	8.5*	8.5*	7.4*	7.4*	6.3*	6.3*	5.2*	5.2*									5.1*	5.1*	16.6

Height Can be slewed through 360° In longitudinal position of undercarriage Max. reach \* Limited by hydr. capacity

The lift capacities on the stick end without attachment are stated in metric tons (t) and are valid on a firm, level supporting surface with blocked oscillating axle. These capacities can be slewed through 360° with the undercarriage in the transverse position. Capacities in the longitudinal position of the undercarriage (±15°) are specified over the rigid axle with the stabilizers down. Indicated loads based on the ISO 10567 standard and do not exceed 75% of tipping or 87% of hydraulic capacity. The lift capacity values indicated are attained at the corresponding operating temperature. This operating temperature is ensured by continuous movement of the boom. Weights of fitted attachments (grabs, load hooks, etc.) and load accommodation attachment are to be deducted from the lift capacity values. The lift capacity of the unit is limited by its stability, the lifting capability of the hydraulic elements, or the maximum permissible lifting capacity of the load hook.

In accordance with the harmonised European Standard EN 474-5, hydraulic excavators used for lifting operations must be equipped with pipe fracture safety valves, an overload warning device, a load hook and a lift capacity chart.

# LH 80 M – Equipment AG21

## Industry – Kinematic 2D

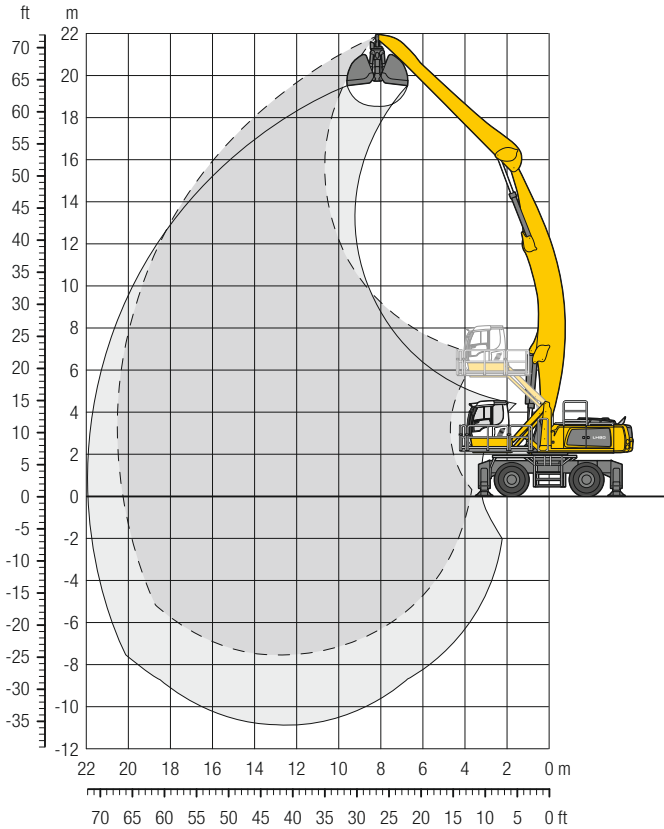

### Dimensions

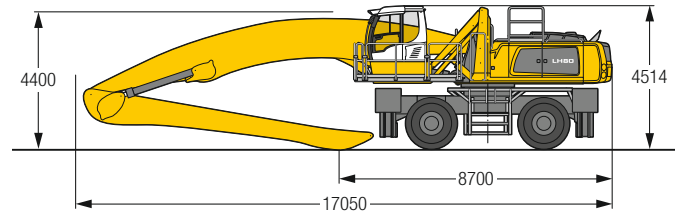

### Operating weight

The operating weight includes the basic machine with 4 point outriggers, hydr. cab elevation, 4 solid tyres, angled boom 12.50 m, straight stick 9.00 m and grab for loose material GMZ 80 / 3.00 m<sup>3</sup>.

Weight	78,100 kg
--------	-----------

m	Undercarriage	6.0 m		7.5 m		9.0 m		10.5 m		12.0 m		13.5 m		15.0 m		16.5 m		18.0 m		19.5 m		21.0 m		m		
		Can be slewed through 360°	In longitudinal position of undercarriage	Can be slewed through 360°	In longitudinal position of undercarriage	Can be slewed through 360°	In longitudinal position of undercarriage	Can be slewed through 360°	In longitudinal position of undercarriage	Can be slewed through 360°	In longitudinal position of undercarriage	Can be slewed through 360°	In longitudinal position of undercarriage	Can be slewed through 360°	In longitudinal position of undercarriage	Can be slewed through 360°	In longitudinal position of undercarriage	Can be slewed through 360°	In longitudinal position of undercarriage	Can be slewed through 360°	In longitudinal position of undercarriage	Can be slewed through 360°	In longitudinal position of undercarriage			
22.5	4 pt. outriggers down																									
21.0	4 pt. outriggers down					10.7*	10.7*																	8.8*	8.8*	10.4
19.5	4 pt. outriggers down							10.8*	10.8*	9.0*	9.0*													8.8*	8.8*	12.6
18.0	4 pt. outriggers down							10.6*	10.6*	9.5*	9.5*	8.7*	8.7*											7.4*	7.4*	14.4
16.5	4 pt. outriggers down									9.4*	9.4*	8.6*	8.6*	8.0*	8.0*									7.0*	7.0*	15.8
15.0	4 pt. outriggers down									9.4*	9.4*	8.6*	8.6*	7.9*	7.9*	7.4*	7.4*							6.8*	6.8*	17.0
13.5	4 pt. outriggers down									10.5*	10.5*	9.4*	9.4*	8.6*	8.6*	7.9*	7.9*	7.3*	7.3*					6.6*	6.6*	17.9
12.0	4 pt. outriggers down									10.7*	10.7*	9.6*	9.6*	8.7*	8.7*	7.9*	7.9*	7.4*	7.4*	6.9*	6.9*			6.6*	6.6*	18.7
10.5	4 pt. outriggers down									10.9*	10.9*	9.7*	9.7*	8.8*	8.8*	8.0*	8.0*	7.4*	7.4*	6.9*	6.9*			6.5*	6.5*	19.4
9.0	4 pt. outriggers down					12.9*	12.9*	11.2*	11.2*	9.9*	9.9*	8.9*	8.9*	8.1*	8.1*	7.5*	7.5*	6.9*	6.9*	6.5*	6.5*			6.4*	6.4*	19.9
7.5	4 pt. outriggers down	19.9*	19.9*	16.0*	16.0*	13.4*	13.4*	11.6*	11.6*	10.2*	10.2*	9.1*	9.1*	8.3*	8.3*	7.6*	7.6*	7.0*	7.0*	6.5*	6.5*			6.3*	6.3*	20.3
6.0	4 pt. outriggers down	21.3*	21.3*	16.9*	16.9*	14.0*	14.0*	12.0*	12.0*	10.5*	10.5*	9.4*	9.4*	8.4*	8.4*	7.7*	7.7*	7.1*	7.1*	6.6*	6.6*			6.0	6.2*	20.5
4.5	4 pt. outriggers down	20.5*	20.5*	17.8*	17.8*	14.6*	14.6*	12.4*	12.4*	10.8*	10.8*	9.6*	9.6*	8.6*	8.6*	7.8*	7.8*	7.2*	7.2*	6.6	6.6*			5.8	6.2*	20.7
3.0	4 pt. outriggers down	6.9*	6.9*	18.7*	18.7*	15.2*	15.2*	12.8*	12.8*	11.1*	11.1*	9.8*	9.8*	8.8*	8.8*	7.9*	7.9*	7.2*	7.2*	6.4	6.6*			5.7	6.1*	20.7
1.5	4 pt. outriggers down	5.0*	5.0*	12.2*	12.2*	15.7*	15.7*	13.2*	13.2*	11.4*	11.4*	10.0*	10.0*	8.9*	8.9*	8.0*	8.0*	7.2	7.3*	6.3	6.6*			5.7	6.0*	20.6
0	4 pt. outriggers down	4.9*	4.9*	9.7*	9.7*	15.9*	15.9*	13.4*	13.4*	11.5*	11.5*	10.1*	10.1*	9.0*	9.0*	8.0	8.0*	7.0	7.2*	6.1	6.5*			5.7	5.9*	20.4
-1.5	4 pt. outriggers down	5.5*	5.5*	9.2*	9.2*	15.9*	15.9*	13.4*	13.4*	11.6*	11.6*	10.1*	10.1*	9.0*	9.0*	7.8	8.0*	6.8	7.1*	6.0	6.2*			5.7	5.8*	20.2
-3.0	4 pt. outriggers down	6.3*	6.3*	9.4*	9.4*	15.4*	15.4*	13.2*	13.2*	11.4*	11.4*	10.0*	10.0*	8.8	8.8*	7.6	7.8*	6.7	6.8*	5.8*	5.8*			5.6*	5.6*	19.7
-4.5	4 pt. outriggers down	7.2*	7.2*	10.0*	10.0*	14.8*	14.8*	12.7*	12.7*	11.0*	11.0*	9.6*	9.6*	8.5*	8.5*	7.4*	7.4*	6.3*	6.3*					5.3*	5.3*	19.2
-6.0	4 pt. outriggers down					13.5*	13.5*	11.8*	11.8*	10.3*	10.3*	9.0*	9.0*	7.8*	7.8*	6.7*	6.7*							5.8*	5.8*	17.7
-7.5	4 pt. outriggers down							9.2*	9.2*	8.0*	8.0*													7.9*	7.9*	13.6

Height Can be slewed through 360° In longitudinal position of undercarriage Max. reach \* Limited by hydr. capacity

The lift capacities on the stick end without attachment are stated in metric tons (t) and are valid on a firm, level supporting surface with blocked oscillating axle. These capacities can be slewed through 360° with the undercarriage in the transverse position. Capacities in the longitudinal position of the undercarriage (±15°) are specified over the rigid axle with the stabilizers down. Indicated loads based on the ISO 10567 standard and do not exceed 75% of tipping or 87% of hydraulic capacity. The lift capacity values indicated are attained at the corresponding operating temperature. This operating temperature is ensured by continuous movement of the boom. Weights of fitted attachments (grabs, load hooks, etc.) and load accommodation attachment are to be deducted from the lift capacity values. The lift capacity of the unit is limited by its stability, the lifting capability of the hydraulic elements, or the maximum permissible lifting capacity of the load hook.

In accordance with the harmonised European Standard EN 474-5, hydraulic excavators used for lifting operations must be equipped with pipe fracture safety valves, an overload warning device, a load hook and a lift capacity chart.



# LH 80 M – Equipment AG22

## Industry – Kinematic 2D

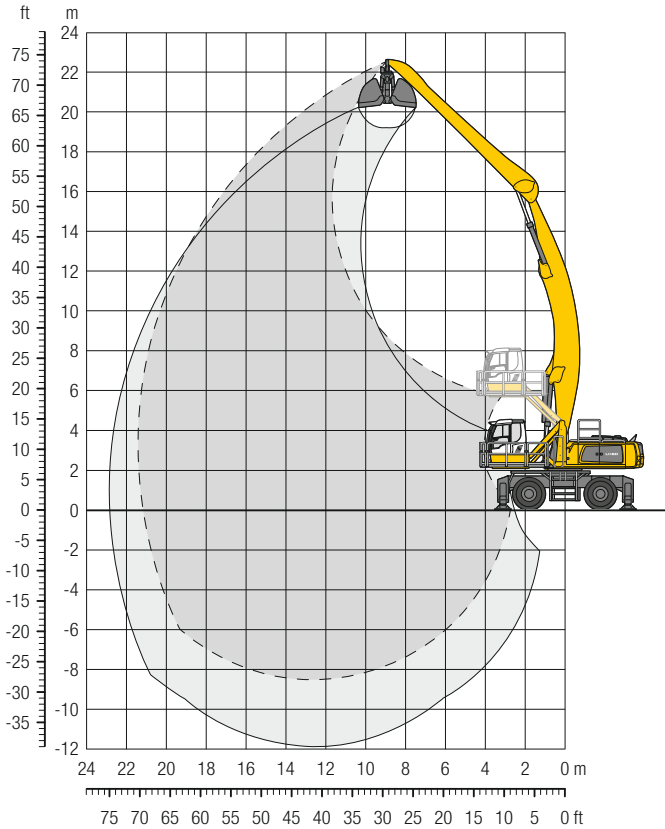

### Dimensions

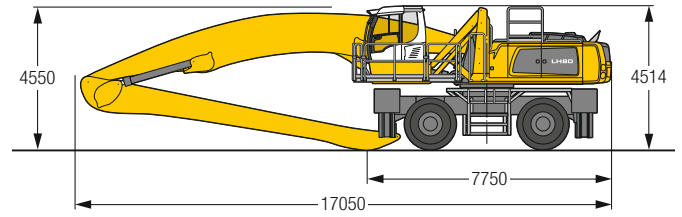

### Operating weight

The operating weight includes the basic machine with 4 point outriggers, hydr. cab elevation, 4 solid tyres, angled boom 12.50 m, straight stick 10.00 m and grab for loose material GMZ 80 / 3.00 m<sup>3</sup>.

Weight 78,500 kg

m	Undercarriage	6.0 m		7.5 m		9.0 m		10.5 m		12.0 m		13.5 m		15.0 m		16.5 m		18.0 m		19.5 m		21.0 m		m			
		☐	☐	☐	☐	☐	☐	☐	☐	☐	☐	☐	☐	☐	☐	☐	☐	☐	☐	☐	☐	☐	☐				
22.5	4 pt. outriggers down			8.4*	8.4*																		8.4*	8.4*	9.0		
21.0	4 pt. outriggers down							8.7*	8.7*															7.2*	7.2*	11.8	
19.5	4 pt. outriggers down									8.8*	8.8*	7.1*	7.1*											6.6*	6.6*	13.8	
18.0	4 pt. outriggers down									9.1*	9.1*	8.3*	8.3*	6.9*	6.9*									6.2*	6.2*	15.4	
16.5	4 pt. outriggers down									9.0*	9.0*	8.2*	8.2*	7.5*	7.5*	6.4*	6.4*							6.0*	6.0*	16.7	
15.0	4 pt. outriggers down									9.0*	9.0*	8.1*	8.1*	7.5*	7.5*	7.0*	7.0*							5.8*	5.8*	17.9	
13.5	4 pt. outriggers down									9.0*	9.0*	8.2*	8.2*	7.5*	7.5*	6.9*	6.9*	6.5*	6.5*					5.7*	5.7*	18.8	
12.0	4 pt. outriggers down									9.1*	9.1*	8.2*	8.2*	7.5*	7.5*	7.0*	7.0*	6.5*	6.5*			5.7*	5.7*		5.6*	19.5	
10.5	4 pt. outriggers down							10.4*	10.4*	9.3*	9.3*	8.3*	8.3*	7.6*	7.6*	7.0*	7.0*	6.5*	6.5*			5.7*	5.7*		5.6*	20.1	
9.0	4 pt. outriggers down							10.7*	10.7*	9.5*	9.5*	8.5*	8.5*	7.7*	7.7*	7.1*	7.1*	6.6*	6.6*			6.1*	6.1*		5.7*	20.6	
7.5	4 pt. outriggers down					12.7*	12.7*	11.0*	11.0*	9.7*	9.7*	8.7*	8.7*	7.9*	7.9*	7.2*	7.2*	6.6*	6.6*			6.2*	6.2*		5.7*	21.0	
6.0	4 pt. outriggers down	19.9*	19.9*	15.9*	15.9*	13.3*	13.3*	11.4*	11.4*	10.0*	10.0*	8.9*	8.9*	8.0*	8.0*	7.3*	7.3*	6.7*	6.7*				5.8*	5.8*	5.6	21.2	
4.5	4 pt. outriggers down	21.4*	21.4*	16.8*	16.8*	13.9*	13.9*	11.8*	11.8*	10.3*	10.3*	9.1*	9.1*	8.2*	8.2*	7.4*	7.4*	6.8*	6.8*			6.3*	6.3*	5.7	5.8*	21.4	
3.0	4 pt. outriggers down	15.2*	15.2*	17.7*	17.7*	14.4*	14.4*	12.2*	12.2*	10.6*	10.6*	9.3*	9.3*	8.3*	8.3*	7.5*	7.5*	6.9*	6.9*			6.3*	6.3*	5.5	5.8*	21.4	
1.5	4 pt. outriggers down	7.8*	7.8*	18.4*	18.4*	14.9*	14.9*	12.6*	12.6*	10.8*	10.8*	9.5*	9.5*	8.5*	8.5*	7.6*	7.6*	6.9*	6.9*			6.2	6.3*	5.4	5.7*	21.4	
0	4 pt. outriggers down	6.4*	6.4*	12.6*	12.6*	15.3*	15.3*	12.8*	12.8*	11.0*	11.0*	9.7*	9.7*	8.6*	8.6*	7.7*	7.7*	6.9	7.0*			6.0	6.3*	5.3	5.6*	21.2	
-1.5	4 pt. outriggers down	6.3*	6.3*	10.7*	10.7*	15.5*	15.5*	13.0*	13.0*	11.2*	11.2*	9.8*	9.8*	8.6*	8.6*	7.7	7.7*	6.7	6.9*			5.9	6.2*		5.3	20.9	
-3.0	4 pt. outriggers down	6.6*	6.6*	10.1*	10.1*	15.3*	15.3*	13.0*	13.0*	11.1*	11.1*	9.7*	9.7*	8.6*	8.6*	7.5	7.6*	6.5	6.8*			5.8	5.9*		5.3*	20.5	
-4.5	4 pt. outriggers down	7.2*	7.2*	10.2*	10.2*	14.9*	14.9*	12.7*	12.7*	10.9*	10.9*	9.5*	9.5*	8.4*	8.4*	7.3	7.4*	6.5	6.5*			5.5*	5.5*		5.1*	20.0	
-6.0	4 pt. outriggers down	7.8*	7.8*	10.6*	10.6*	14.0*	14.0*	12.0*	12.0*	10.4*	10.4*	9.1*	9.1*	7.9*	7.9*	6.9*	6.9*	5.9*	5.9*						4.9*	4.9*	19.3
-7.5	4 pt. outriggers down			12.6*	12.6*	11.0*	11.0*	9.6*	9.6*	8.3*	8.3*	7.2*	7.2*	6.1*	6.1*										5.7*	5.7*	17.1

☐ Height ☐ Can be slewed through 360° ☐ In longitudinal position of undercarriage ☐ Max. reach \* Limited by hydr. capacity

The lift capacities on the stick end without attachment are stated in metric tons (t) and are valid on a firm, level supporting surface with blocked oscillating axle. These capacities can be slewed through 360° with the undercarriage in the transverse position. Capacities in the longitudinal position of the undercarriage (±15°) are specified over the rigid axle with the stabilizers down. Indicated loads based on the ISO 10567 standard and do not exceed 75% of tipping or 87% of hydraulic capacity. The lift capacity values indicated are attained at the corresponding operating temperature. This operating temperature is ensured by continuous movement of the boom. Weights of fitted attachments (grabs, load hooks, etc.) and load accommodation attachment are to be deducted from the lift capacity values. The lift capacity of the unit is limited by its stability, the lifting capability of the hydraulic elements, or the maximum permissible lifting capacity of the load hook. In accordance with the harmonised European Standard EN 474-5, hydraulic excavators used for lifting operations must be equipped with pipe fracture safety valves, an overload warning device, a load hook and a lift capacity chart.

# LH 80 C EW – Equipment GA18

## Industry – Kinematic 2A

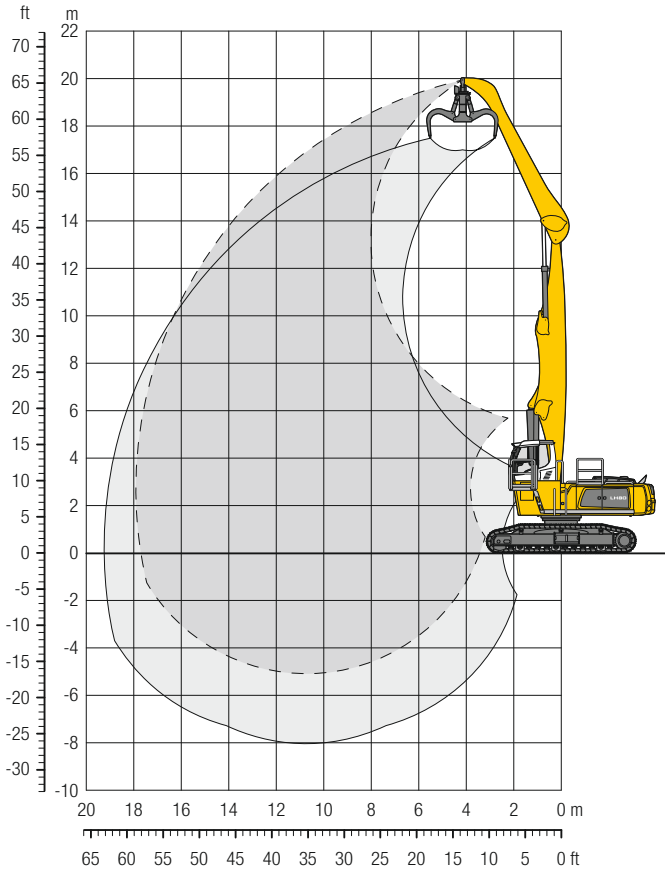

### Dimensions

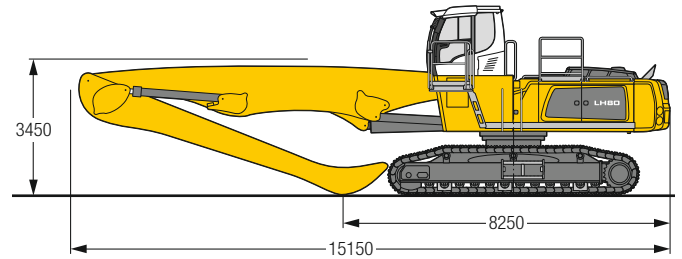

### Operating weight and ground pressure

The operating weight includes the basic machine with rigid cab elevation, straight boom 10.50 m, angled stick 7.80 m and multi-tine grab GMM 80-5/1.70 m<sup>3</sup> semi-closed tines.

Weight	68,000 kg
Pad width	600 mm
Ground pressure	on request

m	Undercarriage	6.0 m		7.5 m		9.0 m		10.5 m		12.0 m		13.5 m		15.0 m		16.5 m		18.0 m		19.5 m		21.0 m		m		
		360°	360°	360°	360°	360°	360°	360°	360°	360°	360°	360°	360°	360°	360°	360°	360°	360°	360°	360°	360°	360°	360°	360°	360°	360°
21.0	EW																									
19.5	EW																									
18.0	EW																									
16.5	EW																									
15.0	EW																									
13.5	EW																									
12.0	EW																									
10.5	EW																									
9.0	EW																									
7.5	EW																									
6.0	EW																									
4.5	EW																									
3.0	EW																									
1.5	EW																									
0	EW																									
-1.5	EW																									
-3.0	EW																									
-4.5	EW																									
-6.0	EW																									

Height Can be slewed through 360° In longitudinal position of undercarriage Max. reach \* Limited by hydr. capacity

The lift capacities on the stick end without attachment are stated in metric tons (t) and can be slewed through 360° on a firm, level supporting surface. Capacities are valid for 600 mm wide triple grouser pads (resp. flat pads). Indicated loads based on the ISO 10567 standard and do not exceed 75% of tipping or 87% of hydraulic capacity. The lift capacity values indicated are attained at the corresponding operating temperature. This operating temperature is ensured by continuous movement of the boom. Weights of fitted attachments (grabs, load hooks, etc.) and load accommodation attachment are to be deducted from the lift capacity values. The lift capacity of the unit is limited by its stability, the lifting capability of the hydraulic elements, or the maximum permissible lifting capacity of the load hook. In accordance with the harmonised European Standard EN 474-5, hydraulic excavators used for lifting operations must be equipped with pipe fracture safety valves, an overload warning device, a load hook and a lift capacity chart.

# LH 80 C EW – Equipment GA20

## Industry – Kinematic 2A

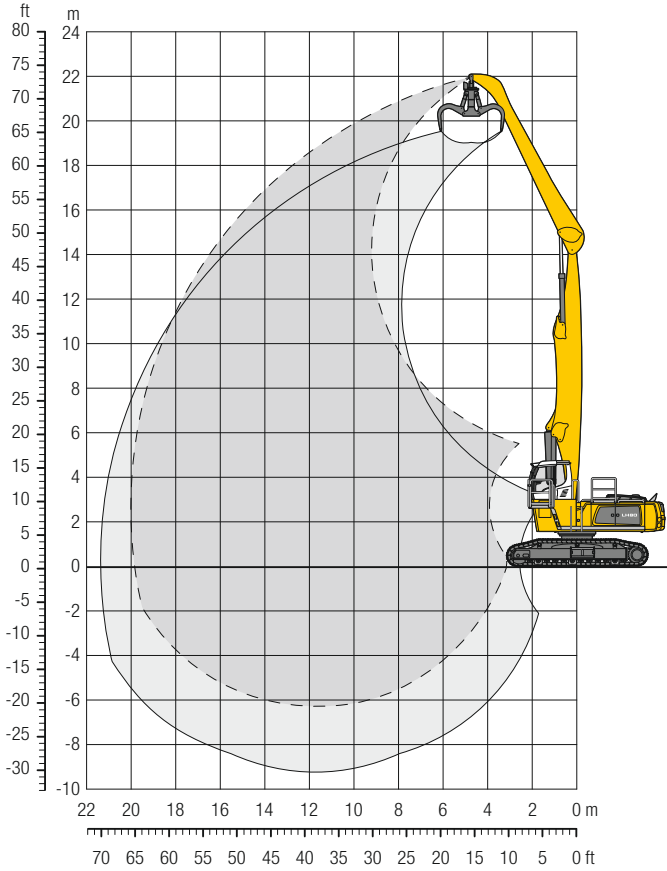

### Dimensions

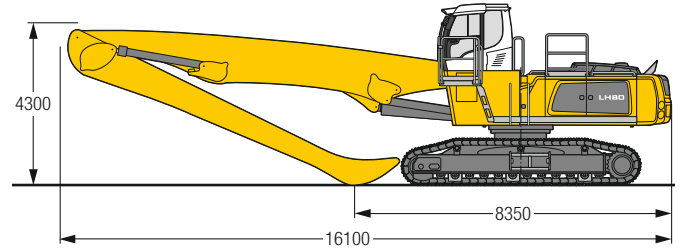

### Operating weight and ground pressure

The operating weight includes the basic machine with rigid cab elevation, straight boom 11.50 m, angled stick 9.00 m and multi-tine grab GMM 80-5 / 1.70 m<sup>3</sup> semi-closed tines.

Weight	69,000 kg
Pad width	600 mm
Ground pressure	on request

m	Undercarriage	6.0 m		7.5 m		9.0 m		10.5 m		12.0 m		13.5 m		15.0 m		16.5 m		18.0 m		19.5 m		21.0 m		m	
		360°	Long	360°	Long	360°	Long	360°	Long	360°	Long	360°	Long	360°	Long	360°	Long	360°	Long	360°	Long	360°	Long	360°	Long
21.0	EW			11.7*	11.7*																		11.2*	11.2*	7.8
19.5	EW			13.3*	13.3*	11.8*	11.8*	9.6*	9.6*														9.2*	9.2*	10.7
18.0	EW					12.9*	12.9*	11.6*	11.6*	9.7*	9.7*												8.2*	8.2*	12.8
16.5	EW					13.1*	13.1*	11.5*	11.5*	10.3*	10.3*	9.4*	9.4*										7.6*	7.6*	14.4
15.0	EW							11.4*	11.4*	10.2*	10.2*	9.3*	9.3*	7.8	8.5*								6.9	7.2*	15.8
13.5	EW							11.4*	11.4*	10.2*	10.2*	9.2*	9.2*	7.9	8.5*	6.3	7.8*						6.0	6.9*	16.8
12.0	EW					13.0*	13.0*	11.4*	11.4*	10.2*	10.2*	9.2*	9.2*	7.9	8.4*	6.4	7.8*						5.3	6.7*	17.7
10.5	EW					13.2*	13.2*	11.6*	11.6*	10.3*	10.3*	9.3*	9.3*	7.8	8.5*	6.4	7.8*	5.1	6.8				4.8	6.4	18.4
9.0	EW					13.5*	13.5*	11.8*	11.8*	10.4*	10.4*	9.4*	9.4*	7.6	8.5*	6.2	7.8*	5.1	6.8				4.4	6.0	19.0
7.5	EW			16.4*	16.4*	13.9*	13.9*	12.0*	12.0*	10.6*	10.6*	9.0	9.5*	7.4	8.6*	6.1	7.8*	5.0	6.7				4.1	5.6	19.4
6.0	EW	18.5*	18.5*	17.1*	17.1*	14.3*	14.3*	12.3*	12.3*	10.6	10.8*	8.6	9.6*	7.1	8.7*	5.9	7.7	4.9	6.5	4.1	5.5		3.9	5.4	19.8
4.5	EW	22.6*	22.6*	17.9*	17.9*	14.8*	14.8*	12.5	12.6*	10.0	11.0*	8.2	9.7*	6.8	8.7*	5.6	7.5	4.7	6.4	4.0	5.5		3.8	5.2	20.0
3.0	EW	23.7*	23.7*	18.6*	18.6*	14.7	15.2*	11.6	12.9*	9.4	11.2*	7.7	9.8*	6.4	8.5	5.4	7.3	4.6	6.2	3.9	5.4		3.7	5.1	20.0
1.5	EW	8.9*	8.9*	17.4	19.0*	13.4	15.5*	10.7	13.1*	8.8	11.3*	7.3	9.7	6.1	8.2	5.2	7.0	4.4	6.1	3.8	5.3		3.6	5.0	20.0
0	EW	6.7*	6.7*	16.0	16.4*	12.4	15.6*	10.0	13.1*	8.2	11.1	6.9	9.3	5.8	7.9	5.0	6.8	4.3	5.9	3.7	5.2		3.6	4.9*	19.9
-1.5	EW	6.6*	6.6*	13.0*	13.0*	11.7	15.2*	9.5	12.8*	7.8	10.7	6.6	9.0	5.6	7.7	4.8	6.7	4.2	5.8	3.7	4.5*		3.7	4.4*	19.6
-3.0	EW	7.2*	7.2*	12.3*	12.3*	11.3	14.3*	9.1	12.2*	7.5	10.4	6.4	8.8	5.4	7.5	4.7	6.5	4.1	5.3*				3.9	4.5*	18.7
-4.5	EW			12.5*	12.5*	11.0	12.8*	8.9	11.1*	7.3	9.5*	6.2	8.2*	5.4	6.9*	4.7	5.6*						4.4	5.0*	17.1
-6.0	EW							8.8	9.3*	7.3	8.1*	6.2	6.8*									5.8	6.4*	14.1	

Height Can be slewed through 360° In longitudinal position of undercarriage Max. reach \* Limited by hydr. capacity

The lift capacities on the stick end without attachment are stated in metric tons (t) and can be slewed through 360° on a firm, level supporting surface. Capacities are valid for 600 mm wide triple grouser pads (resp. flat pads). Indicated loads based on the ISO 10567 standard and do not exceed 75% of tipping or 87% of hydraulic capacity. The lift capacity values indicated are attained at the corresponding operating temperature. This operating temperature is ensured by continuous movement of the boom. Weights of fitted attachments (grabs, load hooks, etc.) and load accommodation attachment are to be deducted from the lift capacity values. The lift capacity of the unit is limited by its stability, the lifting capability of the hydraulic elements, or the maximum permissible lifting capacity of the load hook. In accordance with the harmonised European Standard EN 474-5, hydraulic excavators used for lifting operations must be equipped with pipe fracture safety valves, an overload warning device, a load hook and a lift capacity chart.

# LH 80 C SW – Equipment AG20

## Industry – Kinematic 2D

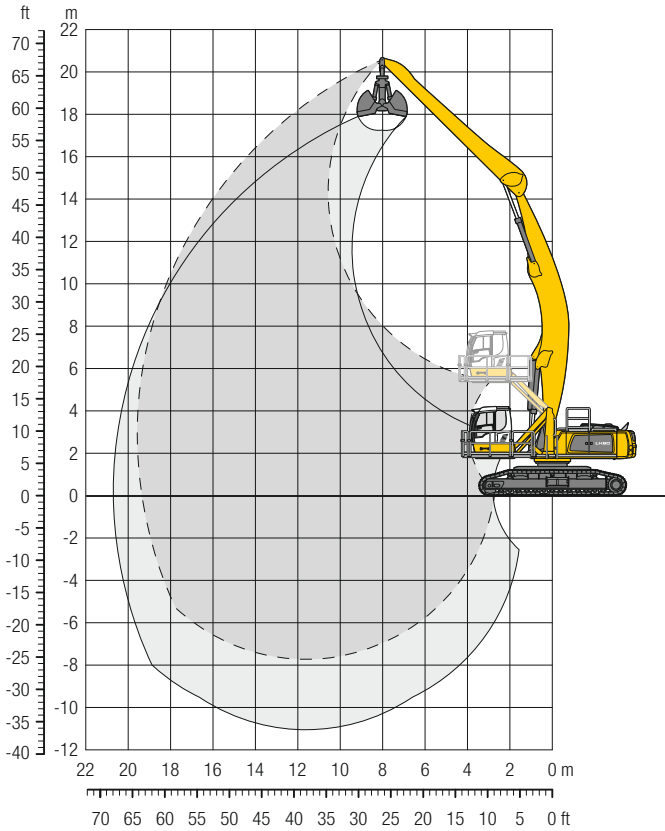

### Dimensions

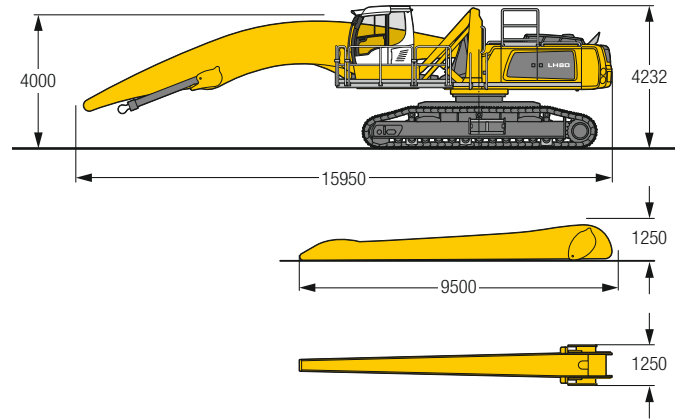

### Operating weight and ground pressure

The operating weight includes the basic machine with hydr. cab elevation, angled boom 11.50 m, straight stick 9.00 m and grab for loose material GMZ 80/3.00 m<sup>3</sup>.

Weight	77,300 kg
Pad width	750 mm
Ground pressure	on request

m	Undercarriage	6.0 m		7.5 m		9.0 m		10.5 m		12.0 m		13.5 m		15.0 m		16.5 m		18.0 m		19.5 m		21.0 m		m			
		SW	SW	SW	SW	SW	SW	SW	SW	SW	SW	SW	SW	SW	SW	SW	SW	SW	SW	SW	SW	SW	SW				
21.0	SW																										
19.5	SW																										
18.0	SW					10.7*	10.7*																				
16.5	SW							10.7*	10.7*	8.8*	8.8*													8.7*	8.7*	10.4	
15.0	SW									9.7*	9.7*	8.9*	8.9*	8.6*	8.6*										7.3*	7.3*	14.2
13.5	SW									9.6*	9.6*	8.9*	8.9*	8.3*	8.3*	7.0*	7.0*								6.9*	6.9*	15.5
12.0	SW									9.7*	9.7*	8.9*	8.9*	8.3*	8.3*	7.8*	7.8*								6.7*	6.7*	16.6
10.5	SW							10.7*	10.7*	10.9*	10.9*	9.9*	9.9*	9.0*	9.0*	8.4*	8.4*	7.9*	7.9*	7.1*	7.1*				6.6*	6.6*	17.5
9.0	SW									10.1*	10.1*	9.2*	9.2*	8.5*	8.5*	7.9*	7.9*	7.4*	7.4*						6.5*	6.5*	18.2
7.5	SW					12.7*	12.7*	11.2*	11.2*	10.1*	10.1*	9.2*	9.2*	8.5*	8.5*	7.9*	7.9*	7.4*	7.4*	6.0	7.1*				6.5*	6.5*	18.8
6.0	SW			15.5*	15.5*	13.3*	13.3*	11.6*	11.6*	10.4*	10.4*	9.4*	9.4*	8.7*	8.7*	8.0*	8.0*	7.4	7.5*						6.4	6.6*	19.2
4.5	SW	20.3*	20.3*	16.5*	16.5*	14.0*	14.0*	12.1*	12.1*	10.8*	10.8*	9.7*	9.7*	8.8*	8.8*	8.2*	8.2*	7.2	7.6*						6.1	6.7*	19.5
3.0	SW	22.3*	22.3*	17.7*	17.7*	14.7*	14.7*	12.7*	12.7*	11.1*	11.1*	10.0*	10.0*	9.1*	9.1*	8.3*	8.3*	7.1	7.7*						5.9	6.8*	19.7
1.5	SW	24.2*	24.2*	18.9*	18.9*	15.5*	15.5*	13.2*	13.2*	11.5*	11.5*	10.3*	10.3*	9.3*	9.3*	8.0	8.4*	6.9	7.7*	5.9	7.1*				5.8	7.0*	19.7
0	SW	10.2*	10.2*	19.9*	19.9*	16.2*	16.2*	13.7*	13.7*	11.9*	11.9*	10.5*	10.5*	9.1	9.4*	7.8	8.6*	6.7	7.8*	5.8	7.0*				5.7	6.9*	19.7
-1.5	SW	7.8*	7.8*	17.3*	17.3*	16.7*	16.7*	14.1*	14.1*	12.2*	12.2*	10.3	10.7*	8.8	9.6*	7.5	8.6*	6.5	7.8*	5.7	6.9*				5.7	6.9*	19.5
-3.0	SW	7.6*	7.6*	13.8*	13.8*	17.0*	17.0*	14.2	14.3*	11.7	12.4*	9.9	10.8*	8.5	9.6*	7.3	8.6*	6.4	7.6*						5.8	6.8*	19.2
-4.5	SW	8.0*	8.0*	12.9*	12.9*	16.9*	16.9*	13.7	14.3*	11.4	12.3*	9.6	10.8*	8.3	9.5*	7.2	8.4*	6.3	7.3*						5.9	6.6*	18.8
-6.0	SW	8.7*	8.7*	13.0*	13.0*	16.4*	16.4*	13.4	14.0*	11.1	12.1*	9.4	10.5*	8.1	9.2*	7.1	8.0*	6.3	6.6*						6.2	6.3*	18.3
-7.5	SW			13.6*	13.6*	15.4*	15.4*	13.2*	13.2*	11.0	11.4*	9.3	9.9*	8.1	8.5*	7.1	7.1*								6.7*	6.7*	16.9
-9.0	SW							11.9*	11.9*	10.3*	10.3*	8.8*	8.8*												8.6*	8.6*	13.6

Height Can be slewed through 360° In longitudinal position of undercarriage Max. reach \* Limited by hydr. capacity

The lift capacities on the stick end without attachment are stated in metric tons (t) and can be slewed through 360° on a firm, level supporting surface. Capacities are valid for 750 mm wide triple grouser pads (resp. flat pads). Indicated loads based on the ISO 10567 standard and do not exceed 75% of tipping or 87% of hydraulic capacity. The lift capacity values indicated are attained at the corresponding operating temperature. This operating temperature is ensured by continuous movement of the boom. Weights of fitted attachments (grabs, load hooks, etc.) and load accommodation attachment are to be deducted from the lift capacity values. The lift capacity of the unit is limited by its stability, the lifting capability of the hydraulic elements, or the maximum permissible lifting capacity of the load hook. In accordance with the harmonised European Standard EN 474-5, hydraulic excavators used for lifting operations must be equipped with pipe fracture safety valves, an overload warning device, a load hook and a lift capacity chart.

# LH 80 M HR – Equipment GA22

## Industry – Kinematic 2A

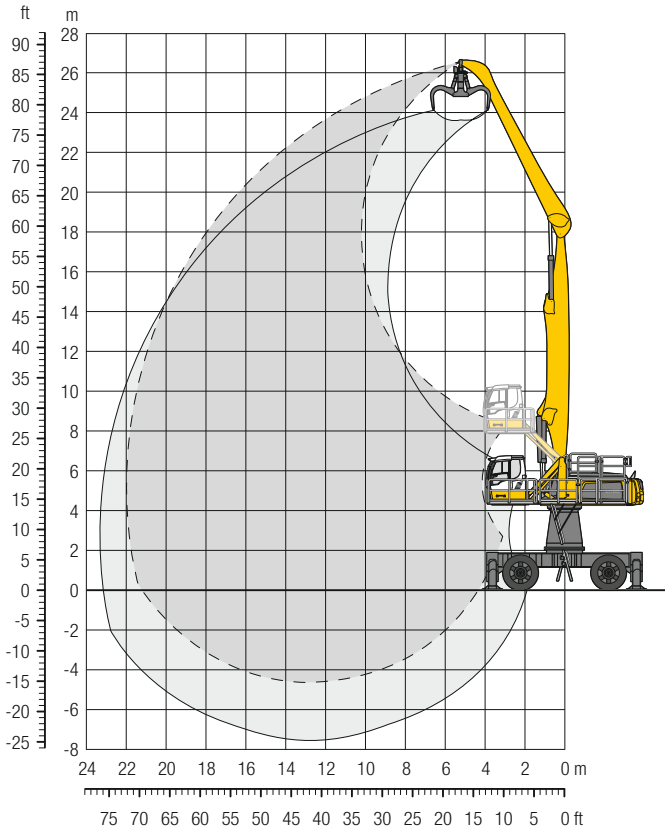

### Dimensions

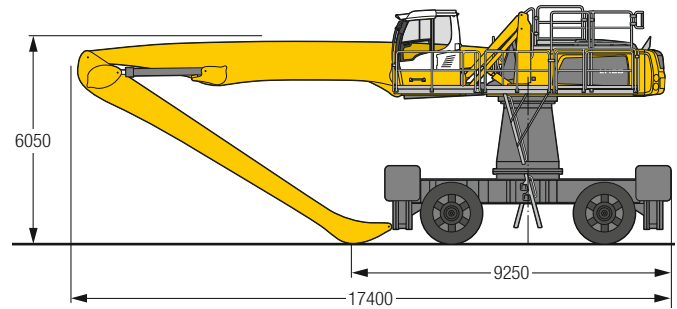

### Operating weight

The operating weight includes the basic machine with 4 point outriggers, turret 2,000 mm, hydr. cab elevation, 4 solid tyres, straight boom 12.50 m, angled stick 10.00 m and multi-tine grab GMM 80-5/1.70 m<sup>3</sup> semi-closed tines.

Weight 91,400 kg

m	Undercarriage	6.0 m		7.5 m		9.0 m		10.5 m		12.0 m		13.5 m		15.0 m		16.5 m		18.0 m		19.5 m		21.0 m		m		
		Can be slewed through 360°	In longitudinal position of undercarriage	Can be slewed through 360°	In longitudinal position of undercarriage	Can be slewed through 360°	In longitudinal position of undercarriage	Can be slewed through 360°	In longitudinal position of undercarriage	Can be slewed through 360°	In longitudinal position of undercarriage	Can be slewed through 360°	In longitudinal position of undercarriage	Can be slewed through 360°	In longitudinal position of undercarriage	Can be slewed through 360°	In longitudinal position of undercarriage	Can be slewed through 360°	In longitudinal position of undercarriage	Can be slewed through 360°	In longitudinal position of undercarriage	Can be slewed through 360°	In longitudinal position of undercarriage	Can be slewed through 360°	In longitudinal position of undercarriage	
25.5	4 pt. outriggers down			11.1*	11.1*																			10.1*	10.1*	8.3
24.0	4 pt. outriggers down					11.0*	11.0*	9.5*	9.5*															8.3*	8.3*	11.3
22.5	4 pt. outriggers down							10.8*	10.8*	9.5*	9.5*	7.4*	7.4*											7.3*	7.3*	13.5
21.0	4 pt. outriggers down							11.4*	11.4*	10.6*	10.6*	9.3*	9.3*	7.3*	7.3*									6.7*	6.7*	15.3
19.5	4 pt. outriggers down							11.8*	11.8*	10.8*	10.8*	9.7*	9.7*	8.9*	8.9*	6.8*	6.8*							6.4*	6.4*	16.7
18.0	4 pt. outriggers down							12.1*	12.1*	10.8*	10.8*	9.7*	9.7*	8.8*	8.8*	8.1*	8.1*							6.1*	6.1*	17.9
16.5	4 pt. outriggers down							12.1*	12.1*	10.8*	10.8*	9.7*	9.7*	8.8*	8.8*	8.0*	8.0*	7.4*	7.4*					5.9*	5.9*	18.9
15.0	4 pt. outriggers down							12.2*	12.2*	10.8*	10.8*	9.7*	9.7*	8.8*	8.8*	8.0*	8.0*	7.4*	7.4*	6.2*	6.2*			5.7*	5.7*	19.7
13.5	4 pt. outriggers down							12.3*	12.3*	10.9*	10.9*	9.7*	9.7*	8.8*	8.8*	8.0*	8.0*	7.3*	7.3*	6.7*	6.7*			5.7*	5.7*	20.4
12.0	4 pt. outriggers down					13.5*	13.5*	12.5*	12.5*	11.0*	11.0*	9.8*	9.8*	8.9*	8.9*	8.1*	8.1*	7.4*	7.4*	6.7*	6.7*			5.6*	5.6*	20.9
10.5	4 pt. outriggers down			13.4*	13.4*	14.8*	14.8*	12.7*	12.7*	11.2*	11.2*	9.9*	9.9*	8.9*	8.9*	8.1*	8.1*	7.4*	7.4*	6.7*	6.7*	6.0*	6.0*	5.6*	5.6*	21.3
9.0	4 pt. outriggers down	13.8*	13.8*	16.6*	16.6*	15.2*	15.2*	13.0*	13.0*	11.3*	11.3*	10.0*	10.0*	9.0*	9.0*	8.1*	8.1*	7.4*	7.4*	6.7*	6.7*	6.0*	6.0*	5.6*	5.6*	21.7
7.5	4 pt. outriggers down	23.9*	23.9*	18.9*	18.9*	15.6*	15.6*	13.3*	13.3*	11.5*	11.5*	10.2*	10.2*	9.1*	9.1*	8.2*	8.2*	7.4*	7.4*	6.6*	6.6*	5.9*	5.9*	5.4*	5.4*	21.9
6.0	4 pt. outriggers down	24.9*	24.9*	19.5*	19.5*	16.0*	16.0*	13.5*	13.5*	11.7*	11.7*	10.2*	10.2*	9.1*	9.1*	8.2*	8.2*	7.3*	7.3*	6.6*	6.6*	5.8*	5.8*	5.1*	5.1*	22.0
4.5	4 pt. outriggers down	7.3*	7.3*	19.8*	19.8*	16.2*	16.2*	13.6*	13.6*	11.8*	11.8*	10.3*	10.3*	9.1*	9.1*	8.1*	8.1*	7.2*	7.2*	6.4*	6.4*	5.6*	5.6*	4.8*	4.8*	22.0
3.0	4 pt. outriggers down	4.9*	4.9*	12.7*	12.7*	16.2*	16.2*	13.7*	13.7*	11.7*	11.7*	10.2*	10.2*	9.0*	9.0*	8.0*	8.0*	7.1*	7.1*	6.2*	6.2*	5.2*	5.2*	4.4*	4.4*	21.9
1.5	4 pt. outriggers down	4.6*	4.6*	9.6*	9.6*	15.9*	15.9*	13.5*	13.5*	11.6*	11.6*	10.1*	10.1*	8.8*	8.8*	7.8*	7.8*	6.8*	6.8*	5.9*	5.9*	4.7*	4.7*	4.0*	4.0*	21.6
0	4 pt. outriggers down	5.1*	5.1*	8.9*	8.9*	15.2*	15.2*	12.9*	12.9*	11.1*	11.1*	9.7*	9.7*	8.5*	8.5*	7.4*	7.4*	6.4*	6.4*	5.3*	5.3*	3.9*	3.9*	3.6*	3.6*	21.2
-1.5	4 pt. outriggers down	5.8*	5.8*	9.1*	9.1*	13.9*	13.9*	12.0*	12.0*	10.4*	10.4*	9.1*	9.1*	7.9*	7.9*	6.8*	6.8*	5.7*	5.7*	4.5*	4.5*			3.9*	3.9*	20.1
-3.0	4 pt. outriggers down			9.6*	9.6*	12.1*	12.1*	10.7*	10.7*	9.3*	9.3*	8.1*	8.1*	7.0*	7.0*	5.9*	5.9*	4.7*	4.7*					4.4*	4.4*	18.3
-4.5	4 pt. outriggers down							7.7*	7.7*	6.7*	6.7*													5.8*	5.8*	14.7

Height Can be slewed through 360° In longitudinal position of undercarriage Max. reach \* Limited by hydr. capacity

The lift capacities on the stick end without attachment are stated in metric tons (t) and are valid on a firm, level supporting surface with blocked oscillating axle. These capacities can be slewed through 360° with the undercarriage in the transverse position. Capacities in the longitudinal position of the undercarriage (±15°) are specified over the rigid axle with the stabilizers down. Indicated loads based on the ISO 10567 standard and do not exceed 75% of tipping or 87% of hydraulic capacity. The lift capacity values indicated are attained at the corresponding operating temperature. This operating temperature is ensured by continuous movement of the boom. Weights of fitted attachments (grabs, load hooks, etc.) and load accommodation attachment are to be deducted from the lift capacity values. The lift capacity of the unit is limited by its stability, the lifting capability of the hydraulic elements, or the maximum permissible lifting capacity of the load hook. In accordance with the harmonised European Standard EN 474-5, hydraulic excavators used for lifting operations must be equipped with pipe fracture safety valves, an overload warning device, a load hook and a lift capacity chart.

# LH 80 M HR – Equipment AG22

## Industry – Kinematic 2D

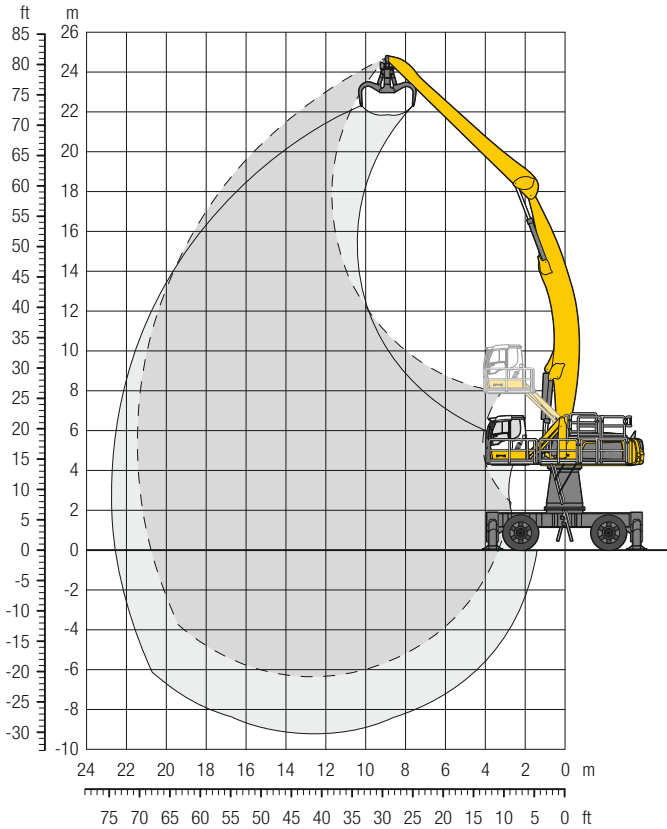

### Dimensions

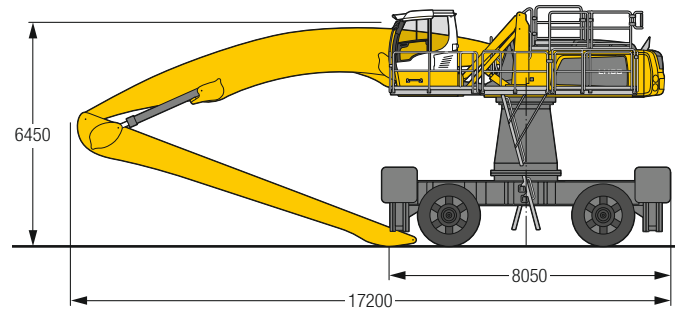

### Operating weight

The operating weight includes the basic machine with 4 point outriggers, turret 2,000 mm, hydr. cab elevation, 4 solid tyres, angled boom 12.50 m, straight stick 10.00 m and multi-tine grab GMM 80-5/1.40 m<sup>3</sup> semi-closed tines.

Weight 91,800 kg

m	Undercarriage	6.0 m		7.5 m		9.0 m		10.5 m		12.0 m		13.5 m		15.0 m		16.5 m		18.0 m		19.5 m		21.0 m		m		
		4 pt. outriggers down	4 pt. outriggers down	4 pt. outriggers down	4 pt. outriggers down	4 pt. outriggers down	4 pt. outriggers down	4 pt. outriggers down	4 pt. outriggers down	4 pt. outriggers down	4 pt. outriggers down	4 pt. outriggers down	4 pt. outriggers down	4 pt. outriggers down	4 pt. outriggers down	4 pt. outriggers down	4 pt. outriggers down	4 pt. outriggers down	4 pt. outriggers down	4 pt. outriggers down	4 pt. outriggers down	4 pt. outriggers down	4 pt. outriggers down	4 pt. outriggers down	4 pt. outriggers down	4 pt. outriggers down
24.0	4 pt. outriggers down																							7.8*	7.8*	10.2
22.5	4 pt. outriggers down								7.8*	7.8*														7.0*	7.0*	12.6
21.0	4 pt. outriggers down								9.2*	9.2*		7.8*	7.8*											6.5*	6.5*	14.5
19.5	4 pt. outriggers down								9.0*	9.0*		8.2*	8.2*	7.6*	7.6*									6.1*	6.1*	16.0
18.0	4 pt. outriggers down								9.0*	9.0*		8.2*	8.2*	7.5*	7.5*	7.0*	7.0*							5.9*	5.9*	17.2
16.5	4 pt. outriggers down								9.0*	9.0*		8.1*	8.1*	7.5*	7.5*	6.9*	6.9*	6.2*	6.2*					5.8*	5.8*	18.2
15.0	4 pt. outriggers down								9.0*	9.0*		8.2*	8.2*	7.5*	7.5*	6.9*	6.9*	6.5*	6.5*					5.7*	5.7*	19.1
13.5	4 pt. outriggers down								9.2*	9.2*		8.3*	8.3*	7.6*	7.6*	7.0*	7.0*	6.5*	6.5*			6.1*	6.1*	5.6*	5.6*	19.8
12.0	4 pt. outriggers down								10.5*	10.5*		9.3*	9.3*	8.4*	8.4*	7.7*	7.7*	7.0*	7.0*	6.5*	6.5*	6.1*	6.1*	5.6*	5.6*	20.3
10.5	4 pt. outriggers down								10.8*	10.8*		9.5*	9.5*	8.6*	8.6*	7.8*	7.8*	7.1*	7.1*	6.6*	6.6*	6.1*	6.1*	5.7*	5.7*	20.8
9.0	4 pt. outriggers down								15.4*	15.4*		12.9*	12.9*	11.1*	11.1*	9.8*	9.8*	8.8*	8.8*	7.9*	7.9*	7.2*	7.2*	6.7*	6.7*	21.1
7.5	4 pt. outriggers down								20.5*	20.5*		16.3*	16.3*	13.5*	13.5*	11.5*	11.5*	10.1*	10.1*	9.0*	9.0*	8.1*	8.1*	7.3*	7.3*	21.3
6.0	4 pt. outriggers down								22.0*	22.0*		17.2*	17.2*	14.1*	14.1*	11.9*	11.9*	10.4*	10.4*	9.2*	9.2*	8.2*	8.2*	7.5*	7.5*	21.4
4.5	4 pt. outriggers down								10.8*	10.8*		18.0*	18.0*	14.6*	14.6*	12.3*	12.3*	10.7*	10.7*	9.4*	9.4*	8.4*	8.4*	7.6*	7.6*	21.4
3.0	4 pt. outriggers down								7.0*	7.0*		15.7*	15.7*	15.1*	15.1*	12.7*	12.7*	10.9*	10.9*	9.6*	9.6*	8.5*	8.5*	7.7*	7.7*	21.3
1.5	4 pt. outriggers down								6.3*	6.3*		11.6*	11.6*	15.4*	15.4*	12.9*	12.9*	11.1*	11.1*	9.7*	9.7*	8.6*	8.6*	7.7*	7.7*	21.1
0	4 pt. outriggers down								6.4*	6.4*		10.4*	10.4*	15.5*	15.5*	13.0*	13.0*	11.2*	11.2*	9.8*	9.8*	8.6*	8.6*	7.7*	7.7*	20.8
-1.5	4 pt. outriggers down								6.8*	6.8*		10.1*	10.1*	15.2*	15.2*	12.9*	12.9*	11.1*	11.1*	9.7*	9.7*	8.5*	8.5*	7.5*	7.5*	20.3
-3.0	4 pt. outriggers down								7.4*	7.4*		10.3*	10.3*	14.6*	14.6*	12.5*	12.5*	10.8*	10.8*	9.4*	9.4*	8.2*	8.2*	7.2*	7.2*	19.7
-4.5	4 pt. outriggers down								10.8*	10.8*		13.5*	13.5*	11.7*	11.7*	10.1*	10.1*	8.8*	8.8*	7.7*	7.7*	6.7*	6.7*	5.6*	5.6*	18.6
-6.0	4 pt. outriggers down								10.4*	10.4*		9.1*	9.1*	7.9*	7.9*	6.8*	6.8*	5.6*	5.6*					6.3*	6.3*	15.7

Height Can be slewed through 360° In longitudinal position of undercarriage Max. reach \* Limited by hydr. capacity

The lift capacities on the stick end without attachment are stated in metric tons (t) and are valid on a firm, level supporting surface with blocked oscillating axle. These capacities can be slewed through 360° with the undercarriage in the transverse position. Capacities in the longitudinal position of the undercarriage (±15°) are specified over the rigid axle with the stabilizers down. Indicated loads based on the ISO 10567 standard and do not exceed 75% of tipping or 87% of hydraulic capacity. The lift capacity values indicated are attained at the corresponding operating temperature. This operating temperature is ensured by continuous movement of the boom. Weights of fitted attachments (grabs, load hooks, etc.) and load accommodation attachment are to be deducted from the lift capacity values. The lift capacity of the unit is limited by its stability, the lifting capability of the hydraulic elements, or the maximum permissible lifting capacity of the load hook. In accordance with the harmonised European Standard EN 474-5, hydraulic excavators used for lifting operations must be equipped with pipe fracture safety valves, an overload warning device, a load hook and a lift capacity chart.

# LH 80 C HR – Equipment GA21

## Industry – Kinematic 2A

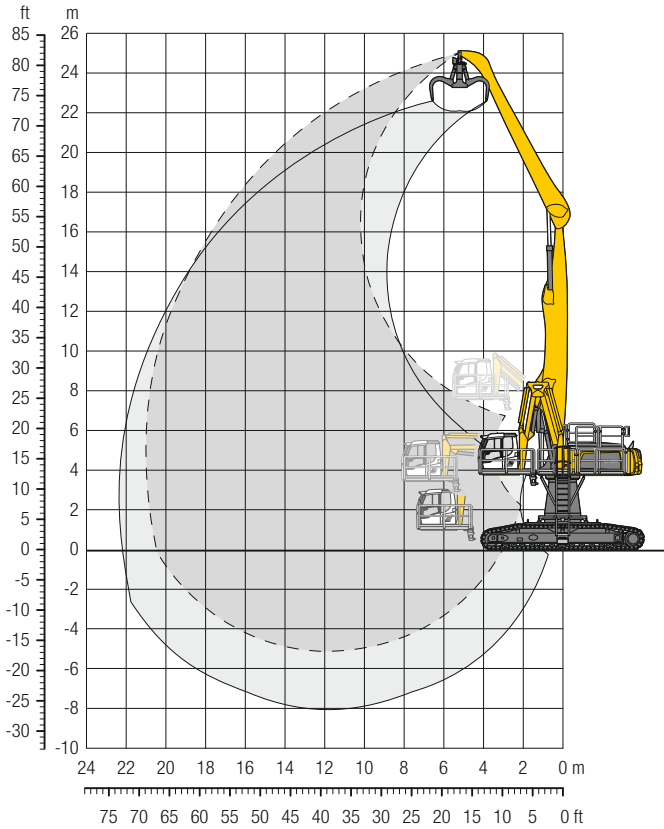

### Dimensions

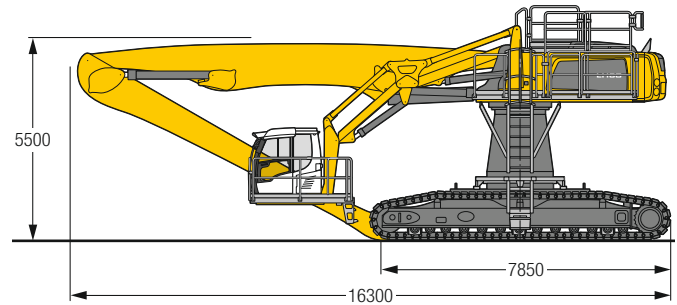

### Operating weight and ground pressure

The operating weight includes the basic machine with turret 2,000 mm, hydr. cab elevation, straight boom 11.50 m, angled stick 10.00 m and multi-tine grab GMM 80-5 / 1.70 m<sup>3</sup> semi-closed tines.

Weight	94,400 kg
Pad width	750 mm
Ground pressure	on request

m	Undercarriage	6.0 m		7.5 m		9.0 m		10.5 m		12.0 m		13.5 m		15.0 m		16.5 m		18.0 m		19.5 m		21.0 m		Max. reach		m
		SW	SW	SW	SW	SW	SW	SW	SW	SW	SW	SW	SW	SW	SW	SW	SW	SW	SW	SW	SW	SW	SW	SW	SW	
24.0	SW			11.1*	11.1*																			9.9*	9.9*	8.3
22.5	SW					11.0*	11.0*	9.3*	9.3*															8.2*	8.2*	11.2
21.0	SW							10.7*	10.7*	9.3*	9.3*													7.3*	7.3*	13.3
19.5	SW							11.4*	11.4*	10.5*	10.5*	9.0*	9.0*											6.7*	6.7*	15.0
18.0	SW							11.8*	11.8*	11.0*	11.0*	10.1*	10.1*	8.6*	8.6*									6.3*	6.3*	16.3
16.5	SW							12.1*	12.1*	11.0*	11.0*	10.0*	10.0*	9.2*	9.2*	7.9*	7.9*							6.0*	6.0*	17.4
15.0	SW							12.2*	12.2*	11.0*	11.0*	10.0*	10.0*	9.1*	9.1*	8.5*	8.5*	6.7*	6.7*					5.8*	5.8*	18.4
13.5	SW							12.3*	12.3*	11.0*	11.0*	10.0*	10.0*	9.2*	9.2*	8.5*	8.5*	7.8*	7.8*					5.7*	5.7*	19.1
12.0	SW							12.5*	12.5*	11.2*	11.2*	10.1*	10.1*	9.2*	9.2*	8.5*	8.5*	7.8*	7.8*	6.3*	6.3*			5.6*	5.6*	19.7
10.5	SW					13.6*	13.6*	12.8*	12.8*	11.4*	11.4*	10.2*	10.2*	9.3*	9.3*	8.5*	8.5*	7.8*	7.8*	7.2*	7.2*			5.6*	5.6*	20.2
9.0	SW			13.5*	13.5*	15.1*	15.1*	13.1*	13.1*	11.6*	11.6*	10.4*	10.4*	9.4*	9.4*	8.6*	8.6*	7.9*	7.9*	7.2*	7.2*			5.6*	5.6*	20.6
7.5	SW	14.3*	14.3*	17.2*	17.2*	15.6*	15.6*	13.5*	13.5*	11.9*	11.9*	10.6*	10.6*	9.5*	9.5*	8.6*	8.6*	7.9*	7.9*	7.1*	7.1*			5.7*	5.7*	20.8
6.0	SW	24.7*	24.7*	19.6*	19.6*	16.2*	16.2*	13.9*	13.9*	12.1*	12.1*	10.7*	10.7*	9.6*	9.6*	8.7*	8.7*	7.9*	7.9*	7.0*	7.0*			5.8*	5.8*	21.0
4.5	SW	26.1*	26.1*	20.4*	20.4*	16.8*	16.8*	14.2*	14.2*	12.3*	12.3*	10.9*	10.9*	9.7*	9.7*	8.7*	8.7*	7.8*	7.8*	6.9*	6.9*	5.8*	5.8*	5.8*	5.8*	21.0
3.0	SW	11.2*	11.2*	21.0*	21.0*	17.1*	17.1*	14.5*	14.5*	12.5*	12.5*	10.9*	10.9*	9.7*	9.7*	8.6*	8.6*	7.7*	7.7*	6.7*	6.7*			5.4*	5.4*	20.9
1.5	SW	7.7*	7.7*	18.8*	18.8*	17.2*	17.2*	14.5*	14.5*	12.5*	12.5*	10.9*	10.9*	9.6*	9.6*	8.5*	8.5*	7.4*	7.4*	6.3*	6.3*			5.0*	5.0*	20.7
0	SW	7.2*	7.2*	14.0*	14.0*	16.9*	16.9*	14.3*	14.3*	12.3*	12.3*	10.7*	10.7*	9.3*	9.3*	8.1*	8.1*	7.0*	7.0*	5.7*	5.7*			4.5*	4.5*	20.4
-1.5	SW	7.5*	7.5*	12.7*	12.7*	16.1*	16.1*	13.6*	13.6*	11.7*	11.7*	10.1*	10.1*	8.8*	8.8*	7.5*	7.5*	6.2*	6.2*					4.7*	4.7*	19.5
-3.0	SW	8.2*	8.2*	12.7*	12.7*	14.6*	14.6*	12.5*	12.5*	10.8*	10.8*	9.3*	9.3*	7.9*	7.9*	6.6*	6.6*							5.2*	5.2*	17.9
-4.5	SW					12.3*	12.3*	10.7*	10.7*	9.3*	9.3*	7.9*	7.9*	6.6*	6.6*									6.3*	6.3*	15.3

Height Can be slewed through 360° In longitudinal position of undercarriage Max. reach \* Limited by hydr. capacity

The lift capacities on the stick end without attachment are stated in metric tons (t) and can be slewed through 360° on a firm, level supporting surface. Capacities are valid for 750 mm wide flat pads. Indicated loads based on the ISO 10567 standard and do not exceed 75% of tipping or 87% of hydraulic capacity. The lift capacity values indicated are attained at the corresponding operating temperature. This operating temperature is ensured by continuous movement of the boom. Weights of fitted attachments (grabs, load hooks, etc.) and load accommodation attachment are to be deducted from the lift capacity values. The lift capacity of the unit is limited by its stability, the lifting capability of the hydraulic elements, or the maximum permissible lifting capacity of the load hook. In accordance with the harmonised European Standard EN 474-5, hydraulic excavators used for lifting operations must be equipped with pipe fracture safety valves, an overload warning device, a load hook and a lift capacity chart.

# LH 80 C Gantry – Equipment AG22

## Industry – Kinematic 2C

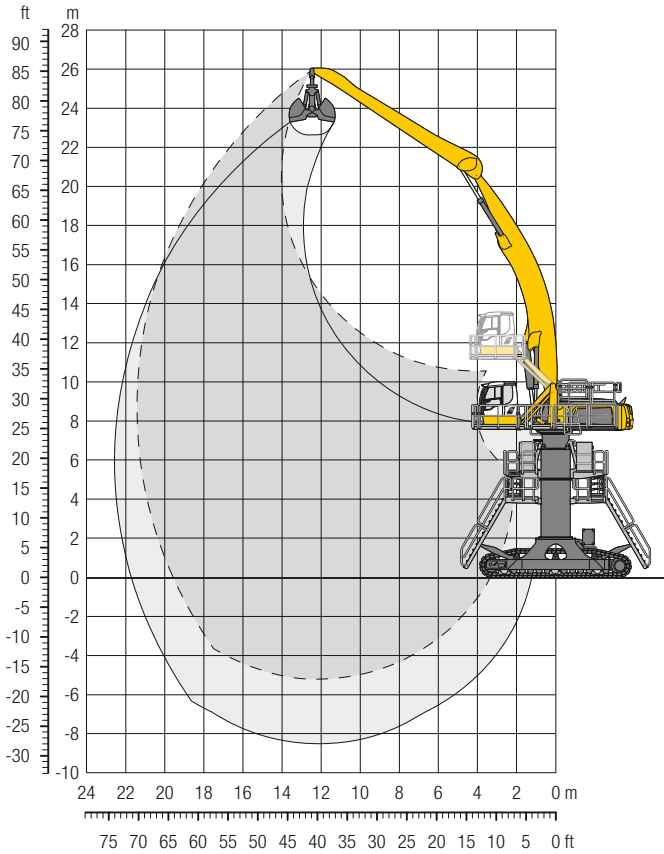

### Dimensions

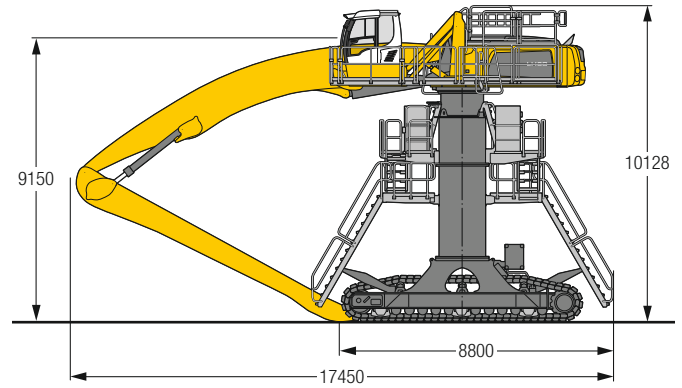

### Operating weight and ground pressure

The operating weight includes the basic machine with hydr. cab elevation, angled boom 12.50 m, straight stick 10.00 m and grab for loose material GMZ 80 / 3.00 m<sup>3</sup>.

Weight	112,500 kg
Pad width	750 mm
Ground pressure	on request

m	Undercarriage	6.0 m		7.5 m		9.0 m		10.5 m		12.0 m		13.5 m		15.0 m		16.5 m		18.0 m		19.5 m		21.0 m		m					
		☞	☞	☞	☞	☞	☞	☞	☞	☞	☞	☞	☞	☞	☞	☞	☞	☞	☞	☞	☞	☞	☞	☞	☞	☞			
25.5	Gantry																							☞	☞	13.1			
24.0	Gantry											7.4*	7.4*												☞	☞	14.8		
22.5	Gantry													6.8*	6.8*										☞	☞	16.3		
21.0	Gantry													6.7*	6.7*	6.3*	6.3*								☞	☞	17.5		
19.5	Gantry													6.7*	6.7*	6.3*	6.3*	5.9*	5.9*						☞	☞	18.4		
18.0	Gantry													6.8*	6.8*	6.3*	6.3*	5.9*	5.9*						☞	☞	19.3		
16.5	Gantry											7.4*	7.4*	6.8*	6.8*	6.3*	6.3*	5.9*	5.9*	5.6*	5.6*				☞	☞	19.9		
15.0	Gantry											7.6*	7.6*	6.9*	6.9*	6.4*	6.4*	6.0*	6.0*	5.7*	5.7*				☞	☞	20.5		
13.5	Gantry										8.6*	8.6*	7.8*	7.8*	7.1*	7.1*	6.5*	6.5*	6.1*	6.1*	5.7*	5.7*				☞	☞	20.9	
12.0	Gantry										10.1*	10.1*	8.9*	8.9*	8.0*	8.0*	7.3*	7.3*	6.7*	6.7*	5.8*	5.8*	5.5*	5.5*		☞	☞	21.2	
10.5	Gantry	18.9*	18.9*	14.9*	14.9*	12.4*	12.4*	10.6*	10.6*	9.3*	9.3*	8.3*	8.3*	7.5*	7.5*	6.8*	6.8*	6.3*	6.3*	5.9*	5.9*	5.5*	5.5*	5.4*	5.4*		☞	☞	21.3
9.0	Gantry	20.5*	20.5*	15.9*	15.9*	13.0*	13.0*	11.1*	11.1*	9.6*	9.6*	8.5*	8.5*	7.7*	7.7*	7.0*	7.0*	6.4*	6.4*	6.0*	6.0*	5.5*	5.5*	5.4*	5.4*		☞	☞	21.4
7.5	Gantry	9.3*	9.3*	16.9*	16.9*	13.7*	13.7*	11.6*	11.6*	10.0*	10.0*	8.8*	8.8*	7.9*	7.9*	7.2*	7.2*	6.5*	6.5*	6.0*	6.0*	5.6*	5.6*	5.4*	5.4*		☞	☞	21.4
6.0	Gantry	6.7*	6.7*	14.2*	14.2*	14.3*	14.3*	12.0*	12.0*	10.3*	10.3*	9.1*	9.1*	8.1*	8.1*	7.3*	7.3*	6.6*	6.6*	6.1*	6.1*	5.5*	5.5*	5.4*	5.4*		☞	☞	21.3
4.5	Gantry	6.2*	6.2*	11.2*	11.2*	14.7*	14.7*	12.3*	12.3*	10.6*	10.6*	9.3*	9.3*	8.2*	8.2*	7.4*	7.4*	6.7*	6.7*	6.1*	6.1*	5.5*	5.5*	5.4*	5.4*		☞	☞	21.0
3.0	Gantry	6.5*	6.5*	10.2*	10.2*	15.0*	15.0*	12.6*	12.6*	10.8*	10.8*	9.4*	9.4*	8.3*	8.3*	7.5*	7.5*	6.7*	6.7*	6.0*	6.0*			5.4*	5.4*		☞	☞	20.7
1.5	Gantry	7.0*	7.0*	10.1*	10.1*	14.9*	14.9*	12.6*	12.6*	10.8*	10.8*	9.4*	9.4*	8.3*	8.3*	7.4*	7.4*	6.6*	6.6*	6.1*	6.1*	5.8*	5.8*	5.4*	5.4*		☞	☞	20.2
0	Gantry	7.6*	7.6*	10.4*	10.4*	14.5*	14.5*	12.3*	12.3*	10.6*	10.6*	9.3*	9.3*	8.1*	8.1*	7.2*	7.2*	6.3*	6.3*	5.3*	5.3*			5.2*	5.2*		☞	☞	19.6
-1.5	Gantry	8.3*	8.3*	11.0*	11.0*	13.6*	13.6*	11.7*	11.7*	10.1*	10.1*	8.8*	8.8*	7.7*	7.7*	6.7*	6.7*	5.7*	5.7*					5.0*	5.0*		☞	☞	18.8
-3.0	Gantry	9.0*	9.0*	11.7*	11.7*	12.2*	12.2*	10.7*	10.7*	9.3*	9.3*	8.1*	8.1*	7.0*	7.0*	5.9*	5.9*							4.6*	4.6*		☞	☞	17.9
-4.5	Gantry					10.3*	10.3*	9.1*	9.1*	7.9*	7.9*	6.8*	6.8*	5.7*	5.7*									5.0*	5.0*		☞	☞	15.8

☞ Height ☞ Can be slewed through 360° ☞ In longitudinal position of undercarriage ☞ Max. reach \* Limited by hydr. capacity

The lift capacities on the stick end without attachment are stated in metric tons (t) and can be slewed through 360° on a firm, level supporting surface. Capacities are valid for 750 mm wide flat pads. Indicated loads based on the ISO 10567 standard and do not exceed 75% of tipping or 87% of hydraulic capacity. The lift capacity values indicated are attained at the corresponding operating temperature. This operating temperature is ensured by continuous movement of the boom. Weights of fitted attachments (grabs, load hooks, etc.) and load accommodation attachment are to be deducted from the lift capacity values. The lift capacity of the unit is limited by its stability, the lifting capability of the hydraulic elements, or the maximum permissible lifting capacity of the load hook. In accordance with the harmonised European Standard EN 474-5, hydraulic excavators used for lifting operations must be equipped with pipe fracture safety valves, an overload warning device, a load hook and a lift capacity chart.



# Liebherr ERC-System

## More performance, less consumption

Lowering the equipment stores energy in the ERC-System. This stored energy is then made available to the machine to provide additional engine power. When the equipment is raised the stored energy is released and is reflected in powerful, homogeneous operating cycles. The result is a clear energy saving – and, at the same time, even greater performance.

## System performance

The energy recovery cylinder is a storage system which is independent of the electric motor or diesel engine. The system performance of material handling machines fitted with the ERC-System is composed of the installed engine power and the energy recovery cylinder. When the equipment is raised, energy from the ERC-System is supplied in addition to the power from the engine.

## ERC-System

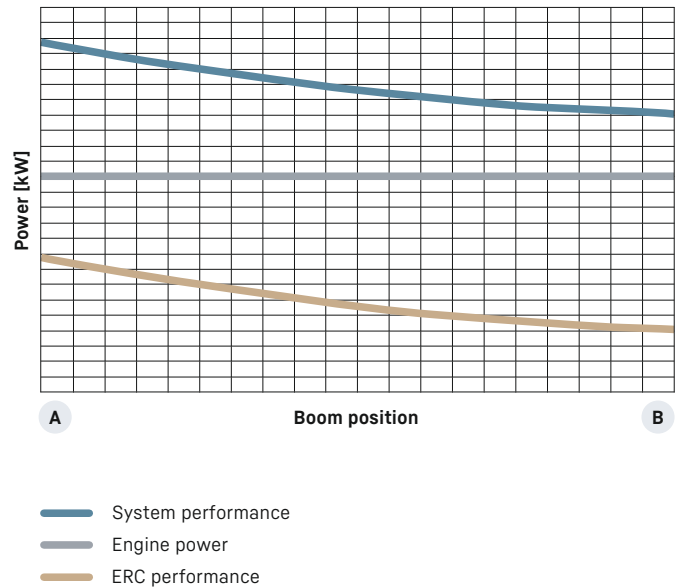

**B** 1. Equipment fitting raised / energy released



2. Lower equipment fitting / store energy  
4. Raise equipment fitting / release energy



**A** 3. Equipment fitting lowered / energy stored

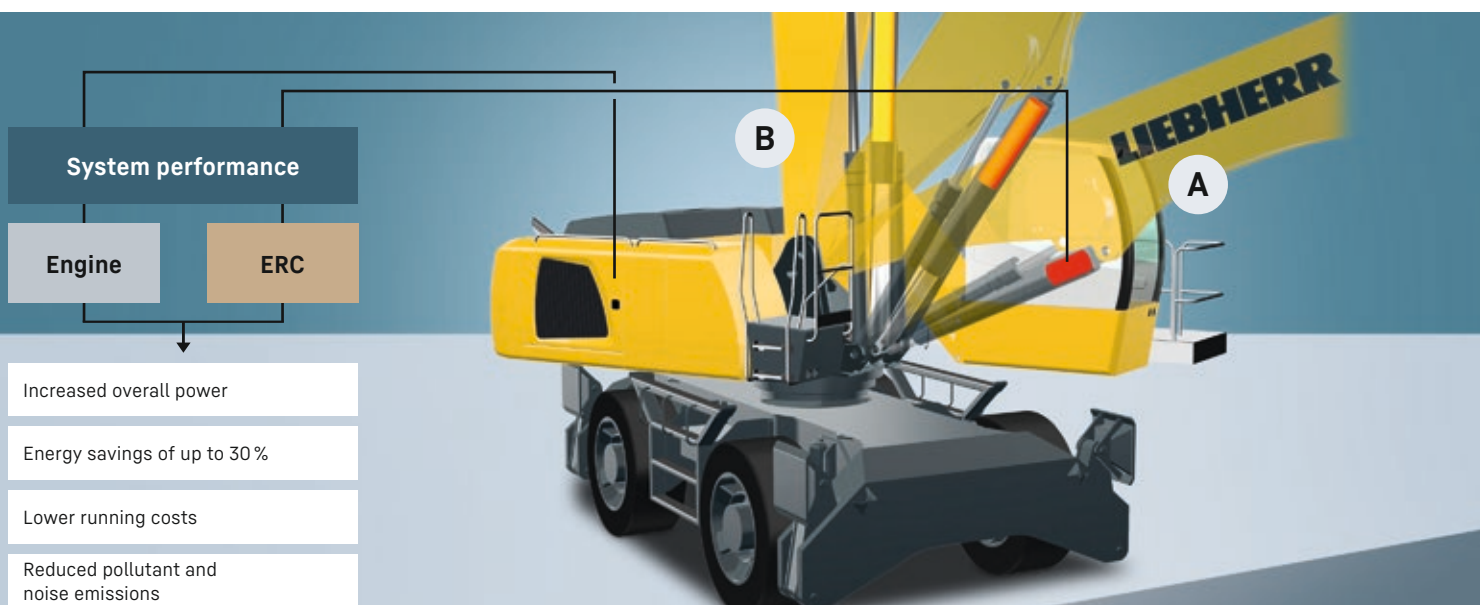

# Equipment

## Undercarriage

	80 M	80 C	80 M HR	80 C HR	80 C Gantry
Track pads, variants		+		+	+
Individual control outriggers	+		•		
Three-piece chain guide		•		•	•
Shuttle axle lock, automatic	•		•		
Outrigger monitoring system	+		+		
Tyres, variants	+		+		
Trailing cable <sup>2)</sup>	•	•	•	•	•
Protection for piston rods, outriggers	+		+		
Two storage compartments <sup>1)</sup>	•				
One storage compartment <sup>2)</sup>	•				
Undercarriage, variants		+			
Cable reel system <sup>2)</sup>	+	+ <sup>3)</sup>	+	+	+

## Uppercarriage

	80 M	80 C	80 M HR	80 C HR	80 C Gantry
Uppercarriage right side light, 1 piece, LED	•	•	•	•	•
Uppercarriage rear light, 2 pieces, LED	+	+			
Uppercarriage underneath rear light, 1 piece, LED			+	+	+
Refuelling system with filling pump <sup>1)</sup>	+	+	+	+	+
Railing on uppercarriage	+	+	•	•	•
Generator	+	+	+	+	+
Main battery switch for electrical system	•	•	•	•	•
Amber beacon, at uppercarriage, LED double flash	+	+	+	+	+
Protection for headlights	+				
Protection for rear lights	+	+			
Tool equipment, extended	•	•	•	•	•

## Hydraulic system

	80 M	80 C	80 M HR	80 C HR	80 C Gantry
Electronic pump regulation	•	•	•	•	•
Liebherr hydraulic oil from -20 °C to +40 °C	•	•	•	•	•
Liebherr hydraulic oil, biologically degradable	+	+	+	+	+
Liebherr hydraulic oil, specially for warm or cold regions	+	+	+	+	+
Magnetic rod in hydraulic tank	•	•	•	•	•
Bypass filter	+	+	+	+	+
Preheating hydraulic oil	+	+	+	+	+

## Engine

	80 M	80 C	80 M HR	80 C HR	80 C Gantry
Fuel anti-theft device <sup>1)</sup>	+	+	+	+	+
Air pre-filter with dust discharge <sup>1)</sup>	+	+	+	+	+
Automatic engine shut-down (time adjustable)	+	+	+	+	+
Preheating fuel <sup>1)</sup>	+	+	+	+	+
Preheating coolant <sup>1)</sup>	+	+	+	+	+
Preheating engine oil <sup>*1)</sup>	+	+	+	+	+

## Cooling system

	80 M	80 C	80 M HR	80 C HR	80 C Gantry
Reversible fan drive	+	+	+	+	+
Protective grid in front of cooler intake	•	•	•	•	•



## Cab

	80 M	80 C	80 M HR	80 C HR	80 C Gantry
Stabilizer assistant	+		+		
Stabilizer, control lever, left console	+		+		
Stabilizer, proportional control on left joystick	●		●		
Cab lights rear, halogen	+	+	+	+	+
Cab lights rear, LED	+	+	+	+	+
Cab lights front, halogen	+	+	+	+	
Cab lights front, halogen (under rain cover)	●	●	●	●	●
Cab lights front, LED	+	+	+	+	+
Cab lights front, LED (under rain cover)	+	+	+	+	+
Armrest adjustable	●	●	●	●	●
Circular bubble level	+	+	●	●	●
Slewing gear brake Comfort, button on the left or right joystick	+	+	+	+	+
Driver profile, personalised (max. 5 drivers)	+	+	+	+	+
Operator's seat Comfort	●	●	●	●	●
Operator's seat Premium	+	+	+	+	+
Driving alarm (acoustic signal is emitted during travel, can be switched ON / OFF)	+	+	+	+	+
Fire extinguisher	+	+	+	+	+
Footrest	+	+	+	+	+
Horn, button on left joystick	●	●	●	●	●
Joystick steering	●	●	●	●	●
Joystick and wheel steering (slim version)	+	+			
Cab elevation, hydraulic (LHC)	●	●	●	●	●
Cab elevation, hydraulic with double parallelogram (LHC-D)			+	+	+
Cab elevation, rigid (LFC)	+	+			
Automatic air conditioning	●	●	●	●	●
Wheel steering (slim version)	+		+		
LiDAT, vehicle fleet management	●	●	●	●	●
Engine shut-down (emergency stop) cab <sup>2)</sup>	●	●	●	●	●
Proportional control	●	●	●	●	●
Radio Comfort, control via display with handsfree set	+	+	+	+	+
Preparation for radio installation	●	●	●	●	●
Back-up alarm (acoustic signal is emitted traveling backward, can not be switched off)	+		+		
Amber beacon, on cab, LED double flash	+	+	+	+	+
Windows made from impact-resistant laminated safety glass	+	+	●	●	●
Windscreen wiper, roof	+	+	+	+	+
Windshield wiper, entire windscreen	●	●	●	●	●
FOPS top guard	+	+	+	+	+
FGPS front guard, tiltable	+	+	+	+	+
Sun visor	+	+	+	+	+
Stationary air-conditioning <sup>2)</sup>	●	●	●	●	●
Left control console, folding	●	●	●	●	●



## Equipment

	80 M	80 C	80 M HR	80 C HR	80 C Gantry
Boom lights, 2 pieces, halogen	●	●	●	●	●
Boom lights, 2 pieces, LED	+	+	+	+	+
Stick lights, 2 pieces, halogen	●	●	●	●	●
Stick lights, 2 pieces, LED	+	+	+	+	+
Boom shutoff (retract / extend), electronically	+	+	●	●	●
Equipment with electro-hydraulic end position control	●	●	●	●	●
AutoLift	+	+	+	+	+
Pressure warning mechanism hoist cylinder	●	●	●	●	●
ERC system	●	●	●	●	●
Filter system for attachment	+	+	+	+	+
Electronic lift limitation	+	+	+	+	+
Boom cylinder cushioning	●	●	●	●	●
Stick camera (with separate monitor), bottom side, with protection	+	+	+	+	+
Load torque limitation	+	+	+	+	+
Liebherr multi coupling system	+	+	+	+	+
Pipe fracture safety valves hoist cylinders	●	●	●	●	●
Pipe fracture safety valves stick cylinders	●	●	●	●	●
Quick coupling system MH 110B	+	+	+	+	+
Protection for piston rod, energy recovering cylinder	+	+	+	+	+
Protection for piston rods, hoist cylinder	+	+	+	+	+
Stick shutoff (retract), electronically	●	●	●	●	●
Stick shutoff (retract / extend), electronically	+	+	+	+	+
Retract stick without pressure	●	●	●	●	●
Sticks with quick coupling	+	+	+	+	+
Overload warning device	+	+	+	+	+



## Complete machine

	80 M	80 C	80 M HR	80 C HR	80 C Gantry
<b>Lubrication</b>					
Lubrication undercarriage, manually - decentralised (grease points)	●				
Lubrication undercarriage, manually - centralised (one grease point)	+		●		
Central lubrication system for uppercarriage and equipment, automatically	●	●	●	●	●
Central lubrication system for undercarriage, automatically	+		+		
Centralised lubrication extended for attachment	+	+	+	+	+
<b>Special coating</b>					
Special coating, variants	+	+	+	+	+
<b>Monitoring</b>					
Rear view monitoring with camera	●	●	●	●	●
Side view monitoring with camera	●	●	●	●	●

● = Standard, + = Option, +<sup>3)</sup> = on request

\* = country-dependent, <sup>1)</sup> not with electric drive, <sup>2)</sup> only with electric drive

Options and / or special equipment, supplied by vendors other than Liebherr, are only to be installed with the knowledge and approval of Liebherr in order to retain warranty.

# Attachments

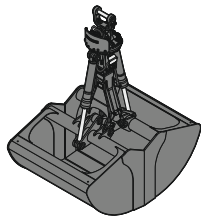

## Grab for loose material

Shells for loose material with cutting edge (without teeth)

Grab model GMZ 50		1,400		1,600		1,800							
Width of shells	mm	1,400		1,600		1,800							
Capacity	m <sup>3</sup>	3.50		4.00		4.50							
Weight	kg	2,615		2,750		2,825							
Grab model GMZ 80		1,300		1,500		1,750		2,000		2,200		2,600	
Width of shells	mm	1,300		1,500		1,750		2,000		2,200		2,600	
Capacity	m <sup>3</sup>	3.00		3.50		4.00		4.50		5.00		6.00	
Weight	kg	2,510		2,625		2,775		2,920		3,255		3,490	
Grab model GMZ 120		1,600		1,800		2,000		2,200					
Width of shells	mm	1,600		1,800		2,000		2,200					
Capacity	m <sup>3</sup>	4.00		4.50		5.00		5.50					
Weight	kg	3,005		3,140		3,280		3,630					



## Multi-tine grab

open

semi-closed

closed, heart-shaped

Grab model GMM 80-4 (4 tines)		1.10		1.40		1.70		1.10		1.40		1.70		1.40		1.70									
Capacity	m <sup>3</sup>	1.10		1.40		1.70		1.10		1.40		1.70		1.40		1.70									
Weight	kg	1,900		1,940		2,000		2,095		2,150		2,210		2,405		2,560									
Grab model GMM 120-4 (4 tines)		1.70		2.00		2.50		3.00		1.70		2.00		2.50		3.00									
Capacity	m <sup>3</sup>	1.70		2.00		2.50		3.00		1.70		2.00		2.50		3.00									
Weight	kg	2,155		2,200		2,255		2,305		2,390		2,445		2,535		2,625									
Grab model GMM 80-5 (5 tines)		1.10		1.40		1.70		0.90		1.10		1.40		1.70		0.90		1.10		1.40		1.70			
Capacity	m <sup>3</sup>	1.10		1.40		1.70		0.90		1.10		1.40		1.70		0.90		1.10		1.40		1.70			
Weight	kg	2,170		2,220		2,290		2,265		2,390		2,465		2,535		2,375		2,440		2,580		2,730			
Grab model GMM 120-5 (5 tines)		1.70		2.00		2.50		3.00		1.70		2.00		2.50		3.00		1.70		2.00		2.50		3.00	
Capacity	m <sup>3</sup>	1.70		2.00		2.50		3.00		1.70		2.00		2.50		3.00		1.70		2.00		2.50		3.00	
Weight	kg	2,485		2,540		2,610		2,670		2,760		2,830		2,935		3,050		2,970		3,110		3,265		3,670	



## Wood grab

Grab model GMH 80 - round overlapping (vertical cylinders)		1.30		1.60		1.90		2.20		2.50	
Size	m <sup>2</sup>	1.30		1.60		1.90		2.20		2.50	
Cutting width	mm	870		870		870		870		870	
Height of grab, closed	mm	2,805		2,905		2,983		3,065		3,142	
Weight	kg	2,155		2,215		2,260		2,295		2,335	
Grab model GMH 120 - round overlapping (vertical cylinders)		2.80		3.20		3.60					
Size	m <sup>2</sup>	2.80		3.20		3.60					
Cutting width	mm	870		870		870					
Height of grab, closed	mm	3,574		3,673		3,754					
Weight	kg	2,725		2,750		2,790					



## Load hook

Max. load	t	25	
Height with suspension	mm	1,220	
Weight	kg	255	

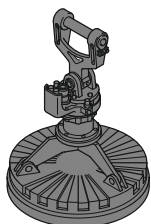

## Magnet devices / lifting magnets

Generator	kW	20		30	
Electromagnet with suspension		11.7		17.8	
Power	kW	11.7		17.8	
Diameter of magnet	mm	1,500		1,700	
Weight	kg	2,400*		3,300*	

\* only magnet plate

Liebherr-Hydraulikbagger GmbH

Liebherrstraße 12 · 88457 Kirchdorf (Iller), Germany · Phone +49 7354 80-0

info.lhb@liebherr.com · www.liebherr.com · www.facebook.com/LiebherrConstruction