Freestanding appliances 2025

LIEBHERR

Refrigeration and freezing





Optimal Freshness

When it comes to groceries, you care about top quality and an authentic culinary experience. You take detours to visit stalls selling regional cheeses, you appreciate freshly caught fish, and you like to grow your own radishes. Wouldn't it be great if you could still taste this quality, even after several days in the fridge? Almost as if time were standing still? We think it would.

That is what motivates us to constantly develop new and even better solutions that guarantee perfect storage conditions for all kinds of groceries. For long-lasting freshness, to protect valuable vitamins, and for food that tastes as if it had just been bought or harvested. But why not find out for yourself? Check out our 2025 freestanding units.



Rd 4600 ○ Pure series



Contents

Liebherr Group	6
10-year manufacturer's guarantee	8
Quality	10
Sustainability	12
Performance in balance	14
World first: BluRoX	16
Freshness technologies	18
EasyFresh	20
BioFresh	21
BioFresh Professional with HydroBreeze	22
BioFresh Professional with Fish & Seafood Safe	24
Design	26
Convenience and flexibility	32
Water and ice	38
Connectivity	42
User interface	44
Flexible accessories	46
Series	48
Frenchdoor fridge-freezers	52
Side-by-Side fridge-freezers	62
Fridge-freezers	76
XL-Fridge-freezers	84
Fridge-freezers (with bottom freezer)	86
Fridge-freezers (with top freezer)	102
Fridges	104
Fridges	112
Under counter fridges	118
Freezers	124
Freezers	132
Under counter freezers	138
Chest freezer	140
Wine Fridges	142
Outdoor cooler	166
Design & LifeStyle	167



Earthmoving



Material handling



Specialist civil engineering



Mining



Mobile and crawler cranes



Tower Cranes



Concrete technology



Maritime cranes



Aerospace and transportation systems



Gear technology and automation systems



Components



Hotels



Refrigerators and freezers

A tradition of reliability admired the world over.

For 75 years Liebherr has offered high-quality products for pioneering industries. With our customers and partners all over the world, we constantly reach new heights.



One big family

The Liebherr Group was established in 1949 by Hans Liebherr. With a history spanning 75 years, the family-run company is characterised by stability and reliability. Liebherr is one of the biggest manufacturers of construction equipment and is also successful in many other industries. The Group has a decentralised organisation with more than 50,000 employees worldwide and is divided into independently operating business units.

The Group now encompasses 13 product segments – earthmoving machinery, material handling technology, deep foundation machines, mining, mobile and crawler cranes, tower cranes, concrete technology, maritime cranes, aerospace and transportation systems, gear technology and automation systems, refrigerators and freezers, components and hotels – and comprises more than 140 companies across all continents. The holding company of the Group is Liebherr-International AG in Bulle (Switzerland), all of whose shareholders are members of the Liebherr family.

Cutting edge combined with experience: Appliances

The Appliances division was established at the Ochsenhausen site in 1954 and for many years it has played an important part in the development of the Group. For 70 years, Liebherr has been a specialist manufacturer of innovative refrigerators and freezers for domestic and commercial use. With an annual production of more than 2.2 million appliances, Liebherr is one of Europe's leading suppliers of cooling and freezing appliances. The five production sites in Ochsenhausen (Germany), Lienz (Austria), Radinovo (Bulgaria), Kluang (Malaysia) and Aurangabad (India) form a manufacturing network for refrigerators and freezers that meets all the most up-to-date standards.

Liebherr is active all over the world. With a dense network of sales subsidiaries and offices in Bulgaria, Germany, the UK, Austria, Canada, Malaysia, Russia, Switzerland, Singapore, South Africa and the USA, the refrigeration and freezing specialists ensure that customers receive expert advice and that service and maintenance work is provided professionally on site.



Freshness without compromise

Reliability and durability are not just buzzwords for us. Why? Because at Liebherr, every tiny detail must meet our demanding requirements. Every functional part is extensively and intensively tested. This continues until we are convinced that our refrigerators and freezers are of the highest quality.



*This guarantee is offered free charge for our most energy-efficient models; A-C rated freestanding fridge-freezers. With our manufacturer's guarantee, you will not incur any costs for repair and service for 10 years. For more information, registration and guarantee conditions, go to: home.liebherr.com/guarantee

Please note that this guarantee is subject to registration and evidence of a qualifying purchase.

Secure a 10-year manufacturer's guarantee*:



Buy now

Buy a qualifying Liebherr appliance* from our webshop or a Liebherr specialist dealer by 31/12/2025.



Register

Register your appliance within 12 months using our web form or SmartDevice app.



Enjoy

Enjoy 10 years of Liebherr manufacturer's guarantee and long-lasting freshness.



10-year manufacturer's guarantee



10[✓]-year
manufacturer's guarantee



To learn more and view the guarantee terms and conditions,
go to home.liebherr.com/guarantee

CBNsda 575i ◊ Prime series

Even the smallest detail deserves the utmost attention.

We prioritise uncompromising quality – down to the tiniest screw. And we have done so from the very start. We have been manufacturing high-quality refrigerators and freezers and selling them worldwide since 1954. However, at heart we are still a family business with deep roots in Germany. It is here that we continue to develop all our products just as before. German engineering – out of loyalty to our founder and with the knowledge built up by generations of engineers.

Convenience for everybody.

Our new freestanding units are available in different series: Pure, Plus, Prime and Peak. But whatever series you opt for, every single Liebherr comes with uncompromising Liebherr quality. This is because even in the Pure series, every appliance comes with a wide range of features. One example is NoFrost – the automatic defrosting function. Another is our EasyFresh technology for storing fruit and vegetables. Then there is our DuoCooling feature. With two separate refrigerant circuits, it ensures that no air is exchanged between the fridge and freezer compartments. The stored groceries do not dry out and no odours are transferred.



EasyFresh for fruit and vegetables.





CBNstb 579i Δ Peak series

Built to last.

You can experience our quality standards in the smallest of details. For example, before a door hinge is approved by us, it must pass through at least 100,000 opening cycles. This corresponds to a usage period of more than 15 years. We also test all other functional parts to ensure that they can last just as long.

And if, contrary to expectations, a small detail no longer meets your requirements, you or our premium service partners can usually correct it quickly. Because all our appliances are extremely repair-friendly. We keep all essential spare parts in stock for well over 10 years. This practice is not just sustainable, it also saves you money on minor repairs or the purchase of a new appliance.

We don't just say it. We also guarantee it.

During manufacturing we inspect all components of our refrigerators with great care and test them far more rigorously than required by law – and we do this for the last time just before they are packaged. It is only then that our appliances can relax a little. All of our manufacturing sites are certified in accordance with the international standards for quality ISO 9001, energy management ISO 50001 and environmental management ISO 14001. Therefore, nothing could be easier for us than to guarantee for at least two years that our products are free of material and manufacturing faults and are particularly easy to install.

Selected fridge-freezers come with a 10-year guarantee (terms and conditions apply). And with WarrantyPlus you can extend your guarantee to 5 or 10 years on any model.

In short: one thing is certain – you will be able to enjoy your Liebherr for a long time.



Magnetic door gasket ensures safe closing.

Our path to the future.

One thing unites all our product innovations: they all present a path towards greater sustainability. Taking responsibility is one of our core values. That's why we have a decades-long tradition of research and development into eco-friendly products, with the entire product lifecycle in mind.

People and sustainable business

Respect for human rights is of the utmost importance to us. We attach great importance to treating everyone equally and ensuring the health, safety and personal development of our employees. We also want to make a positive contribution to our communities.

What is more, we emphasise responsible and economical practices, including long-term financial planning and self-financing. Fairness towards other market participants, compliance with laws and internal standards and codes of conduct are an integral part of our approach.

Recycling

We are aiming for a sustainable circular economy in the long term and actively design our products to maximise the re-use of the materials in them by making them easy to separate.

Materials

We want to reduce the environmental impact of our business activities and are preparing recyclable products by increasing the use of renewable materials and recycled materials in our appliances and reducing the variety of materials we use. In doing so, we look at the entire product.



Use

We reduce our environmental impact by continuing to offer first-class, energy-efficient products that are extremely long-lasting and easy to repair – supported by forward-looking customer service. We also offer products and solutions that help to reduce food waste. More on this on the following pages.

Production

We want to produce in an environmentally conscious manner by reducing the energy requirements of our plants and increasingly utilising renewable energy sources. By using water responsibly, minimising waste and avoiding pollution, we reduce our environmental impact above and beyond CO₂ emissions.

Perfectly thought out: a powerful, complete package.

Our fridges are real all-rounders. Along with their low power consumption, they also have impressively low noise levels, plenty of space for groceries, a long service life and reliable power reserves for when it really matters. We take account of a great many factors during the development stage and can offer a perfectly balanced appliance. Or to put it another way: all good things come in fours.





Energy consumption

Our new freestanding units occupy top positions in the efficiency rankings. In this way, they protect the precious resources of our environment and – thanks to low electricity costs – your wallet too.



Cooling volume

We have the perfect appliance for all family sizes, lifestyles and niche heights. We make sure that we do not waste a single litre of capacity in the extra-large drawers – right down to the smallest detail, for example with the lighting solutions that have been integrated in the housing to save space.



Noise level

The boundaries between the kitchen and living areas are becoming ever more blurred in modern households. This underlines the importance of particularly quiet appliances. Our new freestanding range therefore offers a wide selection of extremely quiet appliances. Some of our freestanding appliances reach the ultra-quiet level of 33dB.



Cooling performance

Intelligent sensor technology constantly adapts the cooling performance to current use, making our freestanding units very energy-efficient and economical in everyday use. At the same time they also have plenty of power in reserve, for example to cool down a large quantity of groceries after the weekly shop.



Performance in balance perfected: Our BluPerformance technology

What is innovative about our BluPerformance models? We have integrated all of the refrigeration technology in the appliance base. As a result, the appliances of the same size have a considerably greater net capacity. So you have noticeably more space for your food and drink. In addition, we were able to further improve energy efficiency thanks to improved ventilation and extraction in the base. And our appliances are now even quieter. We are certain that this technology will appeal not only to fans of new technology but also to those who value greater storage capacity, energy efficiency, and quiet operation.



High efficiency: This is how economical a Liebherr can be

You can find out how efficient our appliances are using the online tool from the EU-financed projects LABEL2020 and BELT. At this site (tool.label2020.eu) you can view and compare the electricity consumption and lots of other product data for electrical appliances. The calculator also takes account of local electricity prices and shows the costs for the entire period of use. The comparison shows that a Liebherr is worth it!

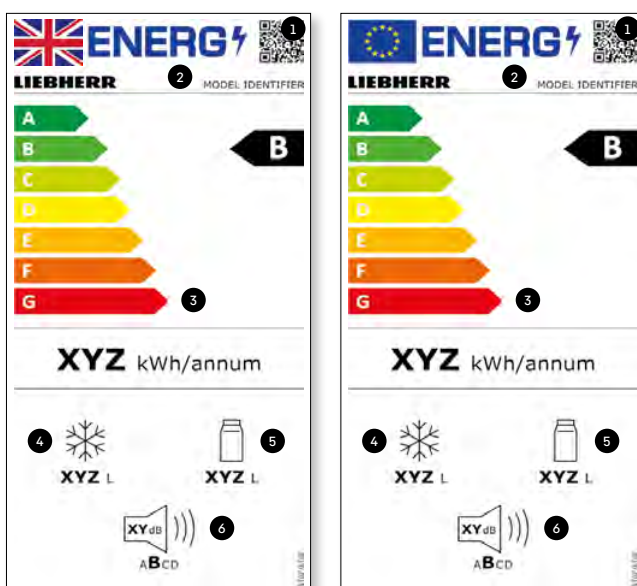

* The term "volume" is defined in current Regulation (EU) 2019/2016. The label for Great Britain includes the Union Jack.

The current energy label for electronic appliances

1. The QR code for identifying the product in the EU's EPREL database (European Product Database for Energy Labelling).
2. The model identifier for manual identification of the product in the EU's EPREL database, e.g. using the article number.
3. The new A to G efficiency scale. Note: G is solely used for wine fridges.
4. The total volume * of all freezer compartments.
5. The total volume * of all cold storage and refrigerator compartments.
6. The noise level is classified in classes A to D.

BluRoX: Cold insulation with innovative vacuum perlite technology.

BluRoX represents a major step towards an energy-efficient and recyclable future. To transform cooling and freezing in a sustainable way, the pioneering BluRoX technology from Liebherr does not simply use conventional polyurethane foam but instead utilises a much more effective form of cold insulation: a vacuum. Finely ground lava stone, known as perlite, stabilises the vacuumed components – with numerous advantages for people and the environment.



BluRoX

The future is circular.



To learn more about this exciting technology and the many advantages of BluRoX, visit: home.liebherr.com/blurox

Revolutionising the future of freezing: The first freezer with BluRoX technology

Thanks to our innovative BluRoX technology, the FNb 505i is the world's first freezer in its product category* to be classified as energy efficiency class B. The door design utilises vacuum technology, stabilised by the volcanic rock perlite. This brings the following unique advantages:

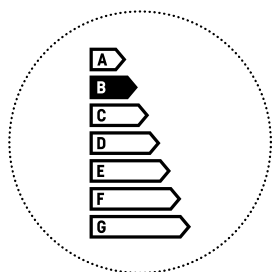

Optimal energy efficiency

The FNb 505i is currently the most energy-efficient freezer in its product category* on the market.

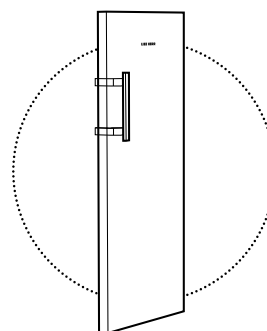

Recyclable door design

Once the appliance has reached the end of its service life, the volcanic rock (perlite) in the door can be removed and reused without the need for significant processing.

*See freestanding freezers, height 165 cm



Unveiled in the Liebherr FNb 505i.

BluRoX can first be seen in the Liebherr FNb 505i. In the door of this freezer, the innovative vacuum insulation celebrates a very special world first: in accordance with the new EU energy label, the Liebherr FNb 505i is the first freezer of its type to be awarded efficiency class "B". And to ensure this remains the case for many years, the high-quality insulation also boasts the durability that Liebherr is renowned for. Find out more about the FNb 505i freezer on page 135.

Freshness technologies

Tasty for longer.

You don't compromise when you're shopping. You look for natural ingredients, the best quality and maximum freshness. Of course, anyone who values good food wants to keep it fresh for as long as possible. That is precisely why we have developed innovative freshness technologies and improve them year after year, so your food still tastes fresh after some time in the refrigerator.



Full-space BioFresh.

Enough space for an entire field.

Especially at harvest time, you may need to store a lot of fruit and vegetables at the same time. Our full-space BioFresh refrigerator is ideal for this. At just over 0 °C and with flexible humidity, everything stays crisp and fresh for a long time. And, if it's a smaller harvest this year, the drawers keep dairy, meat and sausages fresh for longer than in the regular fridge compartment. This appliance is rated in the highest Energy Efficiency Class A.





EasyFresh.
Ideal for fruit and vegetables.
 Unpackaged fruit and vegetables feel right at home here. Stored at the same temperature as the fridge compartment and sealed airtight in the safe, lettuce, for example, is still crisp and fresh after 7 days.



BioFresh.
Our all-rounder.
 The reliable BioFresh technology stores groceries at a temperature just above 0 °C, much cooler than in the rest of the appliance. With the perfect humidity, fruit and vegetables stay fresh even longer in the airtight Fruit & Vegetable Safe. Meat, fish and dairy products can enjoy ideal conditions in the Meat & Dairy Safe.



BioFresh Professional with HydroBreeze.
Refrigerate like the professionals.
 A cold mist that covers fruit and vegetables like a protective balm. It ensures crisp freshness and improves structure - the special wow effect for fruit and vegetables in the BioFresh Professional Safe.



BioFresh Professional with Fish & Seafood Safe.
Like freshly caught fish from the market.
 Particularly delicate foods like fish and seafood are best stored in icy temperatures and at low humidity. The constant temperature of -2 °C in the Fish & Seafood Safe is therefore ideal to keep these items tasting fresh for longer.



DuoCooling.
No drying out.
 The two completely separate refrigeration circuits ensure that there is no air exchange between the fridge and freezer compartments. Groceries do not dry out or spread odour.



NoFrost.
No more defrosting.
 The automatic defrosting function guarantees that frozen foods remain fresh. There is no longer a need to store frozen food temporarily during manual defrosting. The constant optimal freezing remains the same without interruptions.



+10 days

+8 days

+3 days

Easy
Fresh

+10 days

Specifications made in days are comparisons to the normal fridge compartment.



Bio
Fresh

+11 days

+12 days

+40 days

+40 days

+48 days

Cool and misty. Perfect weather for your vegetables.

Our HydroBreeze feature exemplifies our highest standard of freshness. A cold mist covers fruit and vegetables like a protective balm in the BioFresh Professional Safe. The mist ensures crisp freshness, improves structure and keeps produce with fine leaves fresh for longer. It also creates an optical wow effect in the BioFresh Professional Safe.



Nature's freshness secret.

The Salinas valley in California is known as the salad bowl of the USA. And that is because of the particularly favourable climatic conditions. Its proximity to the cool waters of the Pacific means a fine, moist mist covers the valley and its fields in summer. This prevents the crops growing here from drying out. It is precisely this idea which inspired our BioFresh Professional with HydroBreeze.



Every time the door is opened, a fresh, cold mist is generated.

Hydro
Breeze

+8 days

+10 days

+8 days

+12 days

+40 days

+11 days

+12 days



More about
HydroBreeze

Specifications made in days are comparisons
to the normal fridge compartment.

Like freshly caught fish from the market. Our Fish & Seafood Safe.

To keep fish and seafood tasting as fresh as at the market stall, even after a few days, you need a fridge compartment which maintains their freshness; such as our Fish & Seafood Safe. Fish and seafood can be stored here at $-2\text{ }^{\circ}\text{C}$ and low humidity. Perfect conditions to enjoy that freshly caught flavour for much longer.



Specifications made in days are comparisons to the normal fridge compartment.



Flexible use
 The surface of the BioFresh Professional Safe can be adjusted to individual requirements. The -2 °C can be partially or even completely adjusted to a temperature zone at just above 0 °C. This is the optimal storage environment for meat and dairy products. We have illustrated these four options below:

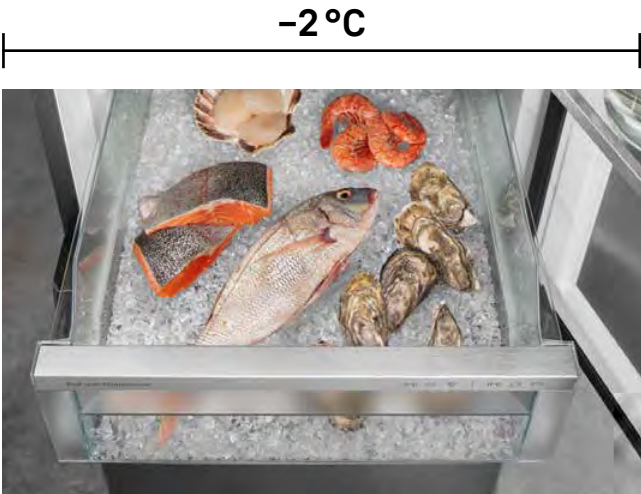

Make a statement. In your kitchen.

Fridges stopped being uniform white kitchen appliances a long time ago. Now that dining and living areas are no longer clearly separated, design plays an increasingly important role. The new puristic design language of Liebherr appliances catches the eye with its exceptional lines, elegant surfaces and simple silhouette.

A classic, exclusive look that allows our appliances to blend seamlessly into any modern kitchen and yet still stand out. But there's no need to say any more: after all, the design already speaks for itself.

Our appliances are available with a display integrated in the door. Or, for purists, in the interior of the appliance.





XRFbd 5220 ◊ Plus series

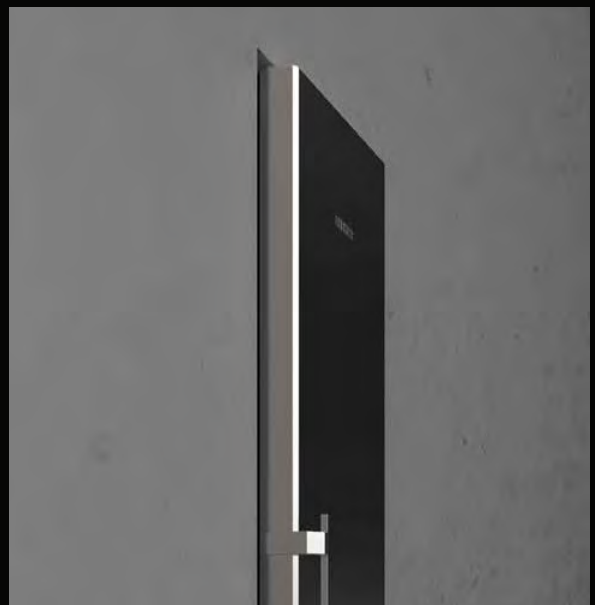

InteriorFit. Fits perfectly.

Make elegant use of niches in the kitchen. With InteriorFit, our freestanding appliances fit into your kitchen without using much space – they don't need a ventilation gap between the appliance and the walls or adjacent furniture. Only the fridge door itself projects into your kitchen. Everything else is invisible.



XRCbs 5295 Δ Peak series

Black
Steel
Interior

Tasteful inside and out:

black stainless steel inside and out makes our BlackSteel appliances a feast for the eyes through and through.

Our options: Elegant, elegant or elegant.

Every kitchen is unique, so why should a fridge be off-the-shelf? We offer a selection of very different high-quality materials, subtle colours and ergonomic handle designs. But no matter what your customers choose: they really can't go wrong with these exclusive options.

Handle solutions

Handle with opening mechanism

The door handle adapts gently to your hand movement and is even easier to open.



Recessed grip

This handle does not extend into the room. The elegant recess harmonises with your kitchen's sleek, handle-free design.



Door fronts

Surfaces

The following designs are available to choose from:

SmartSteel



BlackSteel



TerraSteel
(Only with French doors)



White



SteelFinish



BlackSteel and SmartSteel interior

BlackSteel and TerraSteel appliances have BlackSteel or SmartSteel interiors, creating a striking feature on the interior.



For groceries with the highest requirements.

No matter how much you love the exterior of your Liebherr, at some stage you actually have to open it. So it's lucky that its interior is visually appealing as well.

Design meets functionality.

Traditional and timeless on the one hand, elegant and exclusive on the other. The new design language seamlessly blends into any interior. The interior features elegant glass and stainless steel elements. The precise machining, an eye for detail and the harmonious combination of materials, shapes and colours create an appealing overall appearance. This is subtly highlighted by the lighting concept, LightTower.



CNsdb 5223 ◊ Plus series

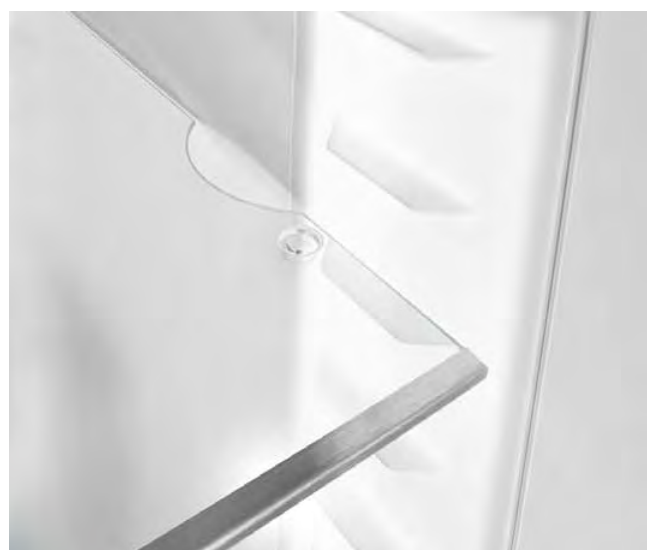

The LightTower concept evenly illuminates the interior while supporting the glass shelves. Flexible, space-saving, unique.

Convenience and flexibility



We have made simple even simpler.

Fridges and freezers are used every day. That is why we develop freestanding appliances that offer ease of use, clarity and flexibility – from the first opening of the door down to the tiniest feature.

Sometimes in life we can have everything we want.

The features of the new freestanding appliances give you more space. The divisible glass shelf, with its effortless one-handed operation, creates space for tall containers and carafes. Do you like things to be well organised? With the VarioBox and the VarioSafe you can store smaller objects neatly in the door or interior – always exactly at the height you like.

How about a cold drink? The glass shelf above the BioFresh Safe can be converted into a bottle shelf in next to no time.

In our fridge-freezers with VarioTemp, the freezer compartments can be switched variably to another temperature. As a result, the freezer compartment can be used as a fridge or cellar compartment.

In turn, VarioSpace provides enough space in the freezer compartment for even the largest turkey or tallest ice cream cake. Speaking of cake: For fans of baking, the fridge compartments in our fridges and fridge-freezers are even spacious enough for a full baking tray.

Full of food. And convenience.

The drawers in the fridge and freezer compartments of our appliances glide in and out smoothly on telescopic rails, so all your groceries are always in perfect reach. Rails also support the pull-out tray with two bottle baskets*, which are easy to remove by their built-in handles. And even once you have found all the ingredients and drinks you need, things remain convenient. Thanks to the SoftSystem. This means that our doors always close gently and quietly, even if the force applied is a little too strong.

*available in selected models



Convenience and flexibility



Drawers on telescopic rails

Pleasantly easy opening and closing – even when fully loaded – ensures that all of the groceries are perfectly accessible.



FlexSystem

Ensures clear order in the BioFresh safe. It is perfect for storing smaller portions of fruit and vegetables or sensitive groceries.



VarioSafe

Allows you to arrange smaller items clearly in the interior – at whatever height you prefer.

Variable temperature space as required

With VarioTemp, there is flexibility for every situation. The freezer compartment can be adjusted to a fridge or cellar compartment, with a variable temperature between $-2\text{ }^{\circ}\text{C}$ and $+14\text{ }^{\circ}\text{C}$.

As a result, you are always perfectly prepared, even for big parties. If necessary, the freezer compartment can be used as an additional cooling zone for appetisers or drinks. Or as a cellar compartment for groceries that are sensitive to cold, such as potatoes, onions and other similar items.

Your family has grown and you are running out of space in your fridge-freezer? Not a problem. VarioTemp allows you to use the freezer compartments as a fridge in your kitchen. If combined with a separate freezer, this means you have enough space to supply even a large family with fresh groceries.



Use as freezer compartment ($-18\text{ }^{\circ}\text{C}$)



Use as fridge compartment (between $-2\text{ }^{\circ}\text{C}$ and $+9\text{ }^{\circ}\text{C}$)



Use as cellar compartment ($+14\text{ }^{\circ}\text{C}$)

Convenience and flexibility



Freezers that are difficult to open: Now a thing of the past.

Thanks to the new EasyOpen technology, our freezers can be opened smoothly and easily at any time. Even without a handle. How do we do it? With the help of an innovative door gasket and the new BluPerformance technology module, we have managed to reduce the door-opening force by half. Space-saving, simple, convenient.



SpaceBox
Ideal for anything that requires a little more space.



SoftSystem soft stop mechanism
The particularly quiet and soft door closing mechanism is integrated into all models from our Prime series upwards.



VarioSpace
Handy for large frozen items, for example a tiered birthday cake.

This spring has its source in the fridge.

With the InfinitySpring, we bring a crystal clear, cold water source right into the heart of your kitchen. Because water is healthy. This makes lugging heavy crates and water in plastic bottles a thing of the past. This relieves the strain on your back and on our environment. Simple and sustainable.

Ice-cold water on tap with no heavy lifting.

The flush-mounted water dispenser is always there when it is needed and almost invisible when it's not. It is suitable for containers of almost any size, including carafes or bottles for soda makers. The integrated filter system ensures perfect water quality. By the way, unlike traditional table-top water filters, this one only needs to be replaced every six months.



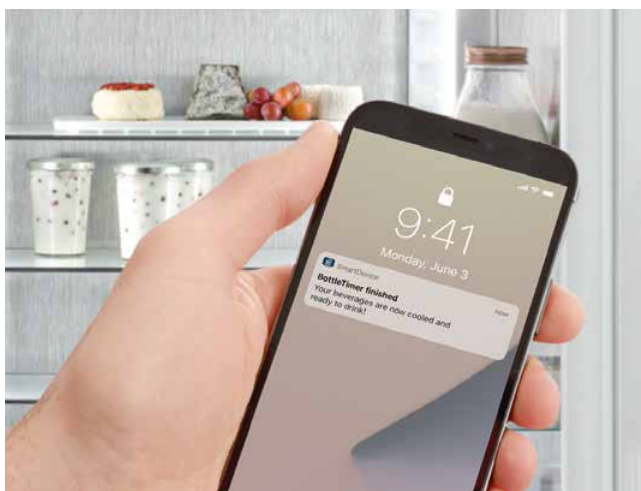

BottleTimer.

Provides extra-fast cooling for drinks. And reminds you via the SmartDevice app not to forget bottles in the freezer compartment.

Cocktails will run out before the ice does.

You like inviting people around and enjoy having as many guests as possible? Then you will love our ice features. One thing is certain: no drink will remain uncooled at your party.





Enough ice for even the largest party: the IceTower.

The IceTower in our freezers sets new standards. It combines two large compartments: the automatic IceMaker for up to 8 kilograms of ice cubes, and another spacious compartment – large enough to store a few family pizzas upright, for example. And because this was not convenient enough for us, both of them glide in and out on a pull-out shelf with telescopic rails. We have even included an ice scoop, so your hands stay warm.



Ice in a jiffy with EasyTwist-Ice.

Make a supply of ice cubes quickly – without a fixed water connection. Simply fill the tank with water, let it freeze and then release the ice cubes with a twist. The EasyTwist-Ice is simple to clean, and is installed in many of our models in the Plus series. Alternatively, it can be added easily as an accessory.



Rains ice cubes: the IceMaker.

The IceMaker produces up to 130 ice cubes a day, which automatically drop into two drawers. When MaxIce is activated, it is even possible to speed up the production of ice cubes if more guests arrive than expected. The IceMaker is connected to the fresh water pipe.

Always well connected

All our appliances are either factory-equipped with a network connection module or can be retrofitted with the SmartDeviceBox.

This way, you will benefit from the many possibilities of our SmartDevice app and from connecting all fridges or freezers to your existing smart home environment. Important status and alarm notifications are sent directly to your smartphone, for example notification of an open fridge door via door alarm. Our SmartDevice app has much more to offer besides: As well as simple management and remote control of your appliances, the app also helps you with tips and tricks for your Liebherr appliance. The right accessories for each appliance, access to instruction manuals and much more can also be found here.



home.liebherr.com/getsmart



You can download the SmartDevice app here:

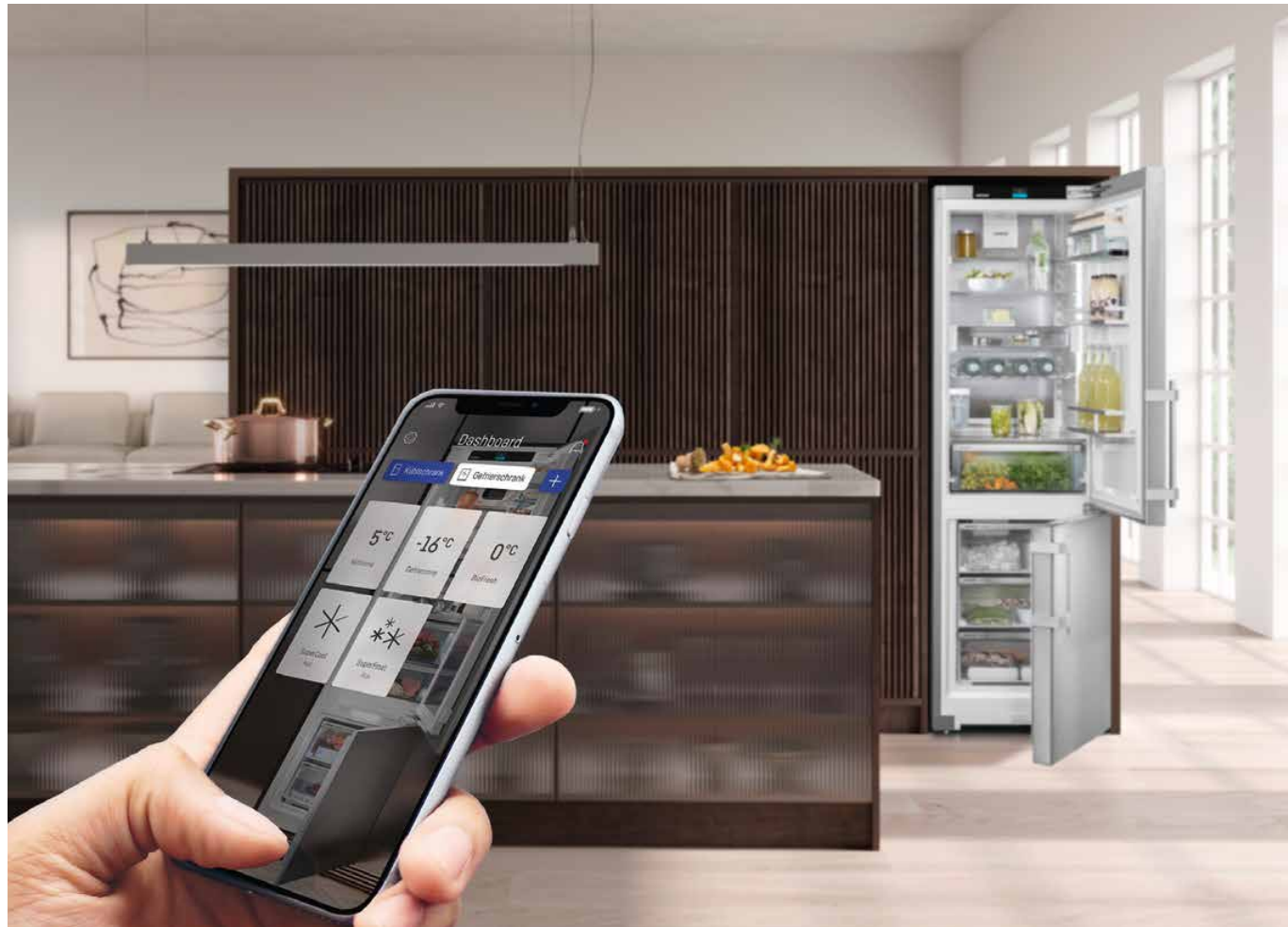



Refrigerators, that leave all your options open – and your doors closed.

We don't develop the refrigerators with the most functions. We develop refrigerators with exactly the right functions to store food safely and give our customers what they really need. To make their lives noticeably easier. And then we implement these features to technical perfection.

You can never be too safe.



Door alarm

Alarm when the door is open, visual as well with pulsating LED lighting.



Temperature alarm

Visual and audible warning as soon as the temperature in the freezer compartment reaches a critical level.



Power failure alarm

Visual and audible alarm in case of power failure for safe storage.



Appliance failure alarm

Optical and acoustic warning in case of appliance failure.



Reminder

Automatic reminder for maintenance and care.



Input lock

Prevents all changes to settings or activation of functions.



DemoMode

For optimal presentation of the appliance in showrooms: User interface and lighting on, cooling system off.

A touch more convenience.



CleaningMode

For a perfect view when cleaning, the lights stay on while the cooling system switches off.



PartyMode

PartyMode activates functions like SuperCool and maximum ice production.



HolidayMode

The fan, SuperCool and SuperFrost are switched off and the fridge temperature is increased to +15 °C to save electricity. The freezer compartment stays switched on.



EnergySaver

Raises the standard temperature to maximum 7 °C to reduce power consumption.



SabbathMode

All lighting and sounds are switched off, reactivating themselves after 80 hours.



Language settings*

Variable language setting for 12 languages on the display.



Status indicator

Be sure everything is OK at all times – thanks to the integrated status display in the appliance door. A blue light indicates everything is OK. If the status is anything but OK, the display flashes red and a warning tone also sounds.



Display in the door



Display behind the door

Core competence cooling.



Temperature display

The display always shows the current temperature value. Flashing items in the menu indicate changes.



SuperFrost

Increased cooling in the freezer compartment for vitamin-preserving freezing.



SuperCool

Increase the cooling performance until the fresh food is as cool as the rest of the contents.



VarioTemp

Variable temperature setting between -2 °C and +14 °C means the entire freezer compartment can also be used for cooling or as a cellar compartment.

Simply smart with the app.



NightMode

All sounds and noises are switched off – and the lighting is dimmed. For undisturbed quiet.



BottleTimer

Extra fast cooling by activating SuperFrost. The app sends an automatic reminder to take the bottles out of the ice compartment.



IceCubeTimer**

Faster rate of ice cube production. As soon as the ice cubes are ready, the app sends a notification.

**Available only in the Prime and Peak series.

Flexible accessories

Practical accessories for every need.

Discover the versatility of the original Liebherr range of accessories for your fridge – and make your daily life a little easier.



Our accessories

Find them online with your dream model at the Liebherr Domestic Appliances store home.liebherr.com or buy them from your Liebherr dealer.



Organisational systems

A fridge compartment design to suit your needs: If you want to sort your groceries clearly, you could use the VarioSafe, VarioBoxes, variable egg trays and the FlexSystem, for example. Additional bottle shelves and clip-on labelling systems provide a clear overview of wine stocks.



VarioBoxes



FlexSystem



Bottle shelf

Useful help of all kinds

From the practical butter dish to the easy-fill ice cube tray with a lid or the handy freezer tray, the range of accessories offers plenty of smart solutions for serving food and keeping it fresh.



Butter dish



Ice cube tray with lid



FlexCube



EasyTwist-Ice

Ice in a jiffy – without a fixed water connection. Quickly build up a stock of ice cubes with a water tank and a simple twist. Easy to retrofit as an accessory.



FreshAir activated charcoal filter

Cleans the circulating air and quickly binds unpleasant odours. The filter is easy to replace and ensures optimum air quality.



SmartDeviceBox

You can retrofit your Liebherr with a SmartDeviceBox to connect it to the internet. The SmartDeviceBox can be installed in just a few steps and will open up the whole world of digital possibilities to you today.

Accessories and Consumables

The compatible accessories for our models can be found in our webshop at home.liebherr.com. Alternatively, you can contact our Customer Service Team who can provide you with further support: Tel: 03330 147 888 option 2, Email: lgb.refrigeration@liebherr.com

Please note that not all accessories fit all models. To find the accessory range for your appliance, please visit our webshop: home.liebherr.com or buy them from your Liebherr dealer.

For a clear overview.
Even before you
open the fridge.

○ Pure ◇ Plus ⬡ Prime △ Peak

Which appliance is right for me?

A customer question that is not always easy to answer. That's why we have made it easier for you to navigate through our product range, by dividing it into four logically structured series.

○ Pure series

The Pure series is our basic class. Simple, clear and perfectly equipped for all essential needs. Appliances in the Pure series are stripped down to the essentials. But are to the absolute highest level of Liebherr quality.

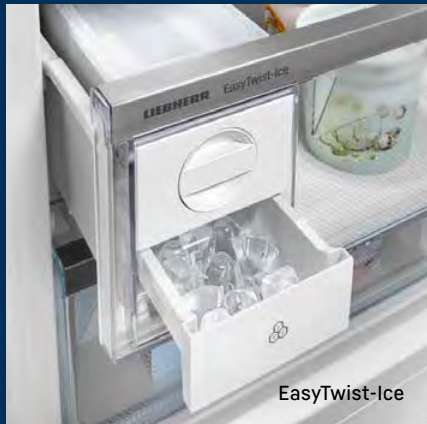
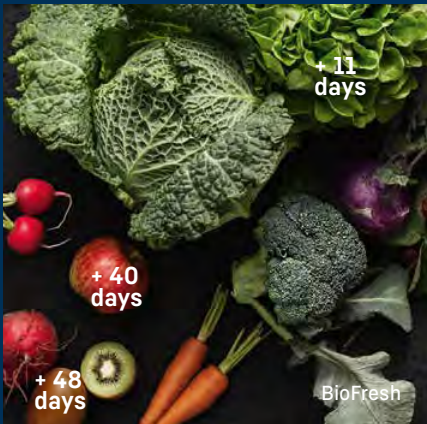

◇ Plus series

The Plus series builds on our Pure series and has many impressive additional details. Above all, Plus means a plus in comfort. The appliances not only provide first-class refrigeration and freezing, they are also just that little bit smarter. They help make operation a little easier.

⊙ Prime series

With the Prime series things get much more classy. It makes an unmistakable mark in terms of design and material. Above all, genuine quality materials are used inside the appliances, such as stainless steel. But special lighting solutions also make the appliances in this series particularly appealing.

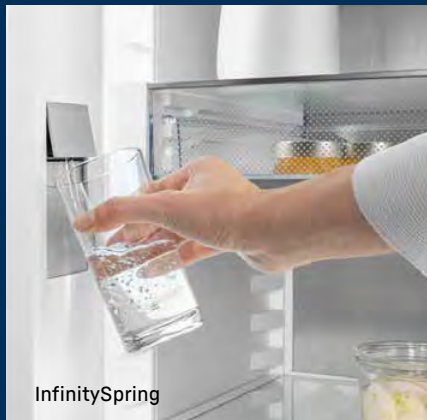
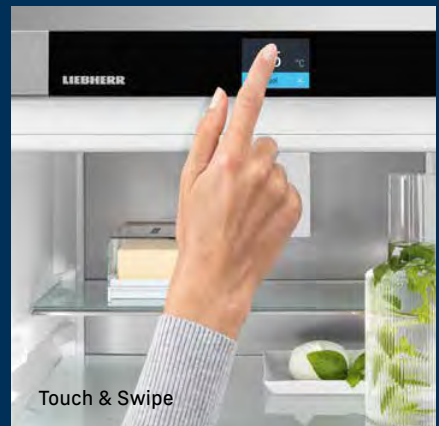
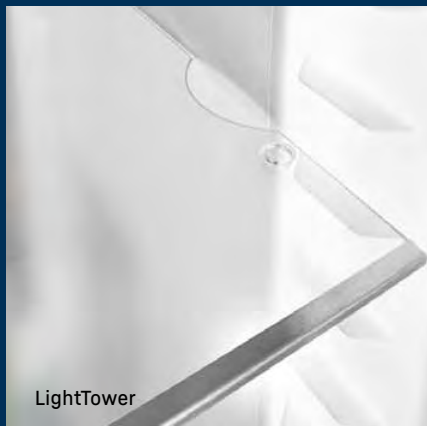

△ Peak series

The Peak series is our premium series. Here the best is combined with the best. There is no compromise. Innovative Liebherr technology meets exceptional high-end design and convenience all in a class of their own. Appliances in this series are for those who want to have it all.

Range overview by appliance height and series

- △ Peak series
- Prime series
- ◇ Plus series
- Pure series

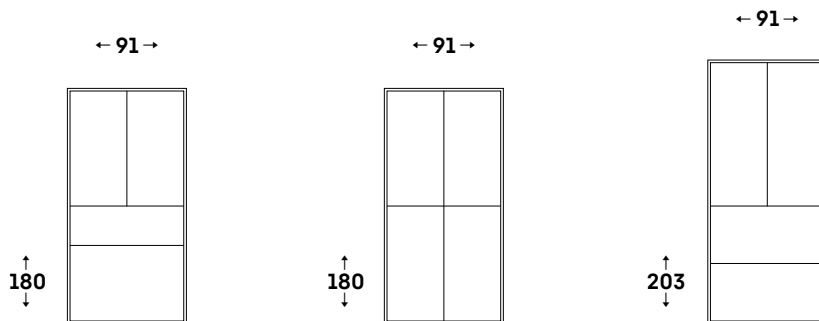

Frenchdoor fridge-freezers	2 doors, 2 freezer drawers	4 doors	2 doors, 2 freezer drawers
BioFresh Professional/HydroBreeze			
Water & Ice Centre/MoodLight/VarioTempZone	MBsddi 9558		
Water & Ice Centre/VarioTempZone		MBsddi 9058	
BioFresh			
Water & Ice Centre/VarioTempZone	MBtsdi 9528	MBsddi 9028	
	MBbsdi 9528		
IceMaker/VarioTempZone	MBsddi 9524	MBbsdi 9024	
		MBsddi 9024	
IceMaker			CBNste 8872
EasyFresh			
EasyTwist-Ice/VarioTempZone		Msdd 9012	



Range overview by appliance height and series

- △ Peak series
- Prime series
- ◇ Plus series
- Pure series

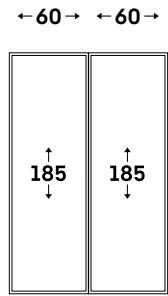

Side-by-Side

Wine/Freezer | Fridge

BioFresh Professional

Wine | HydroBreeze
NoFrost | InfinitySpring
IceMaker

XRCbs 5295

SWNbsd 529i | SRBbsc 529i

XRCst 5295

SWNstd 529i | SRBstc 529i

Freezer | Fridge

BioFresh Professional

NoFrost | HydroBreeze
IceTower | InfinitySpring

XRFbs 5295

SFNbsd 529i | SRBbsc 529i

XRFst 5295

SFNstd 529i | SRBstc 529i

BioFresh

NoFrost | BioFresh
IceTower

XRFsf 5245

SFNsfd 5247 | SRBsfsc 5220

NoFrost | BioFresh

XRFsf 5225

SFNsfd 5227 | SRBsfsc 5220

EasyFresh

NoFrost | EasyFresh
IceTower

XRFsf 5240

SFNsfd 5247 | SRsfd 5220

NoFrost | EasyFresh

XRFbd 5220

SFNbdd 5227 | SRbdd 5220

XRFsf 5220

SFNsfd 5227 | SRsfd 5220

XRF 5220

SFNd 5227 | SRd 5220

Side-by-Side

Fridge-Freezer | Fridge

BioFresh

NoFrost | EasyFresh
IceMaker

XRCsd 5255

SBNsdd 526i | SRsdc 525i

Fridge-Freezer | Fridge-Freezer

EasyFresh

EasyFresh | EasyFresh
NoFrost | NoFrost

XCCsd 5250

SCNsdc 525i 617 | SCNsdc 525i



MBsddi 9558 ◯ Prime series

Frenchdoor fridge-freezers



Series

Frenchdoor fridge-freezers

Two doors,
two freezer drawers



◇ Plus Series



⬡ Prime Series

Four doors



○ Pure Series



◇ Plus Series



⬡ Prime Series

	○ Pure series	◇ Plus series	◇ Prime series
Freshness technology	EasyFresh		
		BioFresh with SoftTelescopic	BioFresh Professional with SoftTelescopic
			HydroBreeze
	DuoCooling	DuoCooling	DuoCooling
	FreshAir filter	FreshAir filter	FreshAir filter
	NoFrost	NoFrost	NoFrost on telescopic rails
	PowerCooling system	PowerCooling system	PowerCooling system
Comfort and flexibility	VarioTemp zone	VarioTemp zone	VarioTemp zone
	SoftSystem soft stop mechanism	SoftSystem soft stop mechanism	SoftSystem soft stop mechanism
	Convenient height adjustment for glass shelves	Convenient height adjustment for glass shelves	Convenient height adjustment for glass shelves
	Storage option for glass shelves	Storage option for glass shelves	Storage option for glass shelves
	Egg tray	Egg tray	Egg tray
	Folding door shelf	Folding door shelf	Folding door shelf
	Flexible door shelf in fridge compartment	Flexible door shelf in fridge compartment	Flexible door shelf in fridge compartment
	Organiser for door shelf in fridge compartment	Organiser for door shelf in fridge compartment	Organiser for door shelf in fridge compartment
	Multi-purpose box	Multi-purpose box	Multi-purpose box
		FlexBox	FlexBox
		Bottle shelf above the BioFresh Safes	Bottle shelf above the BioFresh Safes
	Door shelf in the freezer compartment	Door shelf in the freezer compartment	Door shelf in the freezer compartment
	VarioSpace	VarioSpace	VarioSpace
	FlexDoor system	FlexDoor system	FlexDoor system
Design			MoodLight
			LightTower
	LED ceiling lighting	LED ceiling lighting	LED ceiling lighting
	Touch & Swipe display	Touch & Swipe display	Touch & Swipe display
		LED BioFresh lighting	LED BioFresh lighting
	LED freezer compartment lighting	LED freezer compartment lighting	LED freezer compartment lighting
	GlassLine door shelf	Glass and steel interior	Glass and steel interior
Recessed grips	Recessed grips	Recessed grips	
Connectivity (SmartDeviceBox)	Retrofitable	Integrated (“i” models)	Integrated (“i” models)
Water and ice	EasyTwist-Ice		
	IceMaker	IceMaker	IceMaker
		IceMaker and InfinitySpring	IceMaker and InfinitySpring
		Water & Ice Centre	Water & Ice Centre

Differentiating equipment is **highlighted** in the next higher series.

Quality in every detail



MoodLight

Give the room a highlight: The dimmable, indirect lighting of the recessed grip and the Water & Ice Centre provides a particularly stylish atmosphere.



FlexDoor system

The unique, patented seal system means the doors can be very easily opened and closed – even individually. Quiet and 100% sealed to save energy.



Water & Ice Centre

Provides sufficient cold water, ice cubes and crushed ice around the clock. Practical: In the water dispenser, the amount of water can be individually selected for the desired vessel.



BioFresh with HydroBreeze

Not just a wow effect: The cold mist combined with a temperature in the BioFresh Safe of just over 0 °C gives food that extra boost, keeping your food looking fresh and extending the shelf life.

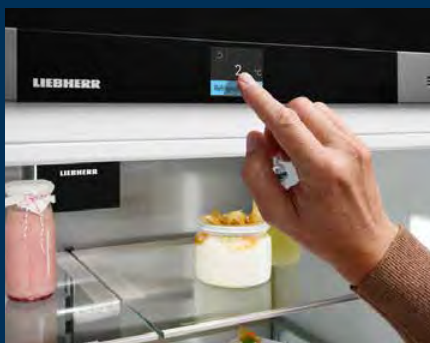

Touch & Swipe display

Operating all Frenchdoor models is incredibly easy and intuitive. All functions can be selected by tapping and swiping.

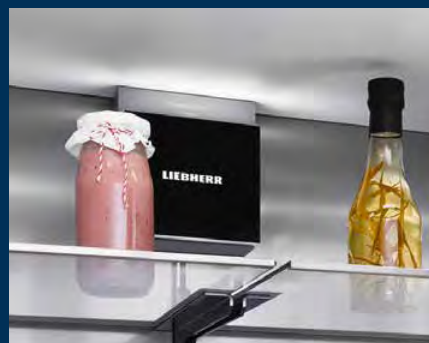

Ambient lighting

Our ambient lighting brings a special design touch to your refrigerator. The all-around lighting produces unique effects in the interior, enhancing the overall atmosphere. Paired with the SmartSteel-designed rear wall and the sleek black high-gloss fan, it creates a captivating and ambient space.



InfinitySpring

The water dispenser for plumbed-in connections provides fresh, chilled water without spilling a drop. Simply press the panel with your carafe or glass and enjoy filtered water. This means you don't need to buy bottled water, which is good for the environment.



Steel interior

Made from high-quality stainless steel – colour matched to the exterior material – the rear wall has an elegant appearance. It is also food-safe, hygienic and reduces the visibility of fingerprints.



SmartDevice

Settings can be adjusted, temperatures checked and relevant status information viewed via a smartphone. "i" models are already fitted with the SmartDeviceBox and other appliances can be retrofitted with the equipment.



EasyTwist-Ice

Prepare a stock of ice cubes quickly and easily without a plumbed-in connection: Fill the tank with water, let it freeze and then release the finished ice cubes with a twist. The EasyTwist-Ice is easy to clean and ensures hygienic ice cube production at all times.



VarioTemp zone

Maximum flexibility: The VarioTemp zone can be precisely adjusted from $-18\text{ }^{\circ}\text{C}$ to $-10\text{ }^{\circ}\text{C}$ and from $-2\text{ }^{\circ}\text{C}$ to $+5\text{ }^{\circ}\text{C}$, meaning it can be flexibly adapted as required for freezing or refrigeration.



Parallel pull-out

Opening and closing the generous NoFrost freezer drawers is very easy, smooth and without a single judder thanks to the parallel pull-out, even when fully loaded.

Frenchdoor fridge-freezers



← 91 →

MBsddi 9558

Prime

Energy efficiency class:	
Energy consumption year / 24 hrs:	284 / 0.778 kWh ¹
Total volume ² :	539 l
Volume:	Fridge: 214.8 l / BioFresh compartment: 94.2 l / 0-star freezer: 16.5 l / Freezer compartment: 230 l
Noise output / noise class:	39 dB(A) / C
Climate rating:	SN-ST (from +10 °C to +38 °C)
Door / side walls:	SmartSteel / silver
Exterior dimensions in cm (h / w / d):	180.5 / 90.6 / 74.5 ¹

Bio Fresh Professional	Hydro Breeze	Duo Cooling	No Frost	Super Cool	Super Frost	Vario Temp Zone	Glass & Steel Interior	Mood Light
Water & Ice Centre	Flex Door System	Soft System	Soft-Telescopic Rails	Touch & Swipe Display	Smart Device			

Controls

- 2.4" TFT-colour display behind-the-door, touch- & swipe
- Digital temperature display for fridge and freezer compartments
- SmartDeviceBox included
- Alarm in case of malfunction: visual and acoustic
- Door alarm: visual and acoustic

Fridge and BioFresh compartments

- PowerCooling with Ambilight and FreshAir activated charcoal filter
- Comfort GlassLine storage shelves with bottle holder, adjustable egg tray
- 2 Tiltable door shelves
- 1 Organiser for door shelf
- 4 GlassLine storage shelves
- Storage option for glass shelf
- Integrated bottle shelf
- LED light column on both sides and LED ceiling lighting
- LED BioFresh lighting
- 2 BioFresh Safes with SoftTelescopic, 1 Fruit & Vegetable Safe with HydroBreeze, 1 Meat & Dairy Safe, 1 FlexBox

- Water & Ice Centre with plumbed-in connection 3/4"

Freezer compartment ********

- Ice cube production in 24 hrs: 1.8 kg
- Ice cube reservoir 1.8 kg
- LED lighting
- Temperature rise time: 12 h
- Freezing capacity in 24 hrs: 6.2 kg
- Multi-purpose box
- Upper freezer drawer can be used as a VarioTempZone

Key features

- Recessed handles
- Transport handles, front and at back, transport castors at back
- Height-adjustable feet at front and back
- Door hinge left fixed/right fixed
- Replaceable door seal
- Dry rear wall in stainless steel with SmartSteel

Available from fourth quarter of 2025



← 91 →

MBtsdi 9528

Plus

Energy efficiency class:	
Energy consumption year / 24 hrs:	284 / 0.778 kWh ¹
Total volume ² :	538 l
Volume:	Fridge: 214.1 l / BioFresh compartment: 93.9 l / Freezer compartment: 230 l / 0-star freezer: 16.6 l
Noise output / noise class:	39 dB(A) / C
Climate rating:	SN-ST (from +10 °C to +38 °C)
Door / side walls:	TerraSteel / TerraSteel
Exterior dimensions in cm (h / w / d):	180.5 / 90.6 / 74.5 ¹

Bio Fresh	Duo Cooling	No Frost	Super Cool	Super Frost	Vario Temp Zone	Water & Ice Centre	Flex Door System	Soft-Telescopic Rails
Touch & Swipe Display	Smart Device							

Controls

- 2.4" TFT-colour display behind-the-door, touch- & swipe
- Digital temperature display for fridge and freezer compartments
- SmartDeviceBox included
- Alarm in case of malfunction: visual and acoustic
- Door alarm: visual and acoustic

Fridge and BioFresh compartments

- PowerCooling with FreshAir activated charcoal filter
- Comfort GlassLine storage shelves with bottle holder, adjustable egg tray, butter dish
- 2 Tiltable door shelves
- 1 Organiser for door shelf
- 4 GlassLine storage shelves
- Storage option for glass shelf
- Integrated bottle shelf
- LED ceiling lighting
- LED BioFresh lighting
- 2 BioFresh Safes with SoftTelescopic, 1 Fruit & Vegetable Safe, 1 Meat & Dairy Safe

- Water & Ice Centre with plumbed-in connection 3/4"

Freezer compartment ********

- Ice cube production in 24 hrs: 1.8 kg
- Ice cube reservoir: 1.8 kg
- LED lighting
- Temperature rise time: 12 h
- Freezing capacity in 24 hrs: 6.2 kg
- Multi-purpose box
- Upper freezer drawer can be used as a VarioTempZone

Key features

- Recessed handles
- Transport handles, front and at back, transport castors at back
- Height-adjustable feet at front and back
- Door hinge left fixed/right fixed
- Replaceable door seal
- Stainless steel with SmartSteel rear wall

Colour / material options:
MBtsdi 9528 in BlackSteel

Available from fourth quarter of 2025

¹ To achieve the indicated energy consumption level, the wall spacers provided with the appliance must be used. These increase the appliance depth by approximately 1.0 cm. If the wall spacers are not used, the appliance will remain fully functional, but will have a slightly higher energy consumption level.



← 91 →

MBsddi 9524

Plus

Energy efficiency class:	
Energy consumption year / 24 hrs:	291 / 0.797 kWh ¹
Total volume ² :	584 l
Volume:	Fridge: 253.5 l / BioFresh compartment: 100.2 l / Freezer compartment: 231 l
Noise output / noise class:	39 dB(A) / C
Climate rating:	SN-ST (from +10 °C to +38 °C)
Door / side walls:	SmartSteel / silver
Exterior dimensions in cm (h / w / d):	180.5 / 90.6 / 74.5 ¹

Bio Fresh	Duo Cooling	No Frost	Super Cool	Super Frost	Vario Temp Zone	Ice Maker	Flex Door System	Soft-Telescopic Rails
Touch & Swipe Display	Smart Device							

Controls

- 2.4" TFT-colour display behind-the-door, touch- & swipe
- Digital temperature display for fridge, BioFresh and freezer compartments
- SmartDeviceBox included
- Alarm in case of malfunction: visual and acoustic
- Door alarm: visual and acoustic

Fridge and BioFresh compartments

- PowerCooling with FreshAir activated charcoal filter
- Comfort GlassLine storage shelves with bottle holder, adjustable egg tray, butter dish
- 2 Tilttable door shelves
- 2 Organisers for door shelf
- 4 GlassLine storage shelves
- Integrated bottle shelf
- LED ceiling lighting
- LED BioFresh lighting
- 2 BioFresh Safes with SoftTelescopic, 1 Fruit & Vegetable Safe, 1 Meat & Dairy Safe

Freezer compartment

- IceMaker with fixed 3/4" water connection
- Ice cube production in 24 hrs: 0.8 kg
- Ice cube reservoir 2.3 kg
- LED lighting
- Temperature rise time: 12 h
- Freezing capacity in 24 hrs: 10.4 kg
- Multi-purpose box
- Upper freezer drawer can be used as a VarioTempZone

Key features

- Recessed handles
- Transport handles, front and at back, transport castors at back
- Height-adjustable feet at front and back
- Door hinge left fixed/right fixed
- Replaceable door seal
- Stainless-steel-look rear wall

Available from fourth quarter of 2025



← 91 →

MBsddi 9058

Prime

Energy efficiency class:	
Energy consumption year / 24 hrs:	286 / 0.783 kWh ¹
Total volume ² :	546 l
Volume:	Fridge: 214.8 l / BioFresh compartment: 94.2 l / Freezer compartment: 237 l / 0-star freezer: 16.5 l
Noise output / noise class:	39 dB(A) / C
Climate rating:	SN-ST (from +10 °C to +38 °C)
Door / side walls:	SmartSteel / silver
Exterior dimensions in cm (h / w / d):	180.5 / 90.6 / 74.5 ¹

Bio Fresh Professional	Hydro Breeze	Duo Cooling	No Frost	Super Cool	Super Frost	Vario Temp Zone	Glass & Steel Interior	Light Tower
Water & Ice Centre	Flex Door System	Soft-Telescopic Rails	Touch & Swipe Display	Vario Space	Smart Device			

Controls

- 2.4" TFT-colour display behind-the-door, touch- & swipe
- Digital temperature display for fridge and freezer compartments
- SmartDeviceBox included
- Alarm in case of malfunction: visual and acoustic
- Door alarm: visual and acoustic

Fridge and BioFresh compartments

- PowerCooling with Ambilight and FreshAir activated charcoal filter
- Comfort GlassLine storage shelves with bottle holder, adjustable egg tray, butter dish
- 2 Tilttable door shelves
- 1 Organiser for door shelf
- 4 GlassLine storage shelves
- Storage option for glass shelf
- Integrated bottle shelf
- LED light column on both sides and LED ceiling lighting
- LED BioFresh lighting
- 2 BioFresh Safes with SoftTelescopic, 1 Fruit & Vegetable Safe with HydroBreeze, 1 Meat & Dairy Safe, 1 FlexBox

- Water & Ice Centre with plumbed-in connection 3/4"

Freezer compartment

- 4 drawers, of which 2 set on telescopic rails, VarioSpace
- Ice cube production in 24 hrs: 1.8 kg
- Ice cube reservoir: 1.8 kg
- LED lighting
- Temperature rise time: 14 h
- Freezing capacity in 24 hrs: 5 kg
- Right-hand freezer compartment can be used as a VarioTempZone

Key features

- Recessed handles
- Transport handles, front and at back, transport castors at back
- Height-adjustable feet at front and back
- Door hinge left fixed/right fixed
- Replaceable door seal
- Dry rear wall in stainless steel with SmartSteel

Available from fourth quarter of 2025

² In accordance with Regulation EU 2019/2016 we indicate the total volume to the nearest integer (rounded off) and the volume of the frozen compartments and refrigeration compartments to one place after the decimal point. You can find the full range of efficiency classes at page 15. According to (EU) 2017/1369 6a.

Frenchdoor fridge-freezers



← 91 →

MBsddi 9028

Plus

Energy efficiency class:	
Energy consumption year / 24 hrs:	285 / 0.780 kWh ¹
Total volume ² :	545 l
Volume:	Fridge: 214.8 l / BioFresh compartment: 93.9 l / Freezer compartment: 237 l / 0-star freezer: 16.5 l
Noise output / noise class:	39 dB(A) / C
Climate rating:	SN-ST (from +10 °C to +38 °C)
Door / side walls:	SmartSteel / silver
Exterior dimensions in cm (h / w / d):	180.5 / 90.6 / 74.5 ¹

Bio Fresh	Duo Cooling	No Frost	Super Cool	Super Frost	Vario Temp Zone	Water & Ice Centre	Flex Door System	Soft-Telescopic Rails
Touch & Swipe Display	Vario Space	Smart Device						

Controls

- 2.4" TFT-colour display behind-the-door, touch- & swipe
- Digital temperature display for fridge and freezer compartments
- SmartDeviceBox included
- Alarm in case of malfunction: visual and acoustic
- Door alarm: visual and acoustic

Fridge and BioFresh compartments

- PowerCooling with FreshAir activated charcoal filter
- Comfort GlassLine storage shelves with bottle holder, adjustable egg tray, butter dish
- 2 Tiltable door shelves
- 1 Organiser for door shelf
- 4 GlassLine storage shelves
- Storage option for glass shelf
- Integrated bottle shelf
- LED ceiling lighting
- LED BioFresh lighting
- 2 BioFresh Safes with SoftTelescopic, 1 Fruit & Vegetable Safe, 1 Meat & Dairy Safe
- Water & Ice Centre with plumbed-in connection 3/4"

Freezer compartment

- 4 drawers, VarioSpace
- Ice cube production in 24 hrs: 1.8 kg
- Ice cube reservoir: 1.8 kg
- LED lighting
- Temperature rise time: 14 h
- Freezing capacity in 24 hrs: 5 kg
- Right-hand freezer compartment can be used as a VarioTempZone

Key features

- Recessed handles
- Transport handles, front and at back, transport castors at back
- Height-adjustable feet at front and back
- Door hinge left fixed/right fixed
- Replaceable door seal
- Stainless-steel-look rear wall

Available from fourth quarter of 2025



← 91 →

MBbsdi 9024

Plus

Energy efficiency class:	
Energy consumption year / 24 hrs:	287 / 0.786 kWh ¹
Total volume ² :	572 l
Volume:	Fridge: 253.5 l / BioFresh compartment: 100.2 l / Freezer compartment: 219 l
Noise output / noise class:	39 dB(A) / C
Climate rating:	SN-ST (from +10 °C to +38 °C)
Door / side walls:	BlackSteel / BlackSteel
Exterior dimensions in cm (h / w / d):	180.5 / 90.6 / 74.5 ¹

Bio Fresh	Duo Cooling	No Frost	Super Cool	Super Frost	Vario Temp Zone	Ice Maker	Flex Door System	Soft-Telescopic Rails
Touch & Swipe Display	Vario Space	Smart Device						

Controls

- 2.4" TFT-colour display behind-the-door, touch- & swipe
- Digital temperature display for fridge and freezer compartments
- SmartDeviceBox included
- Alarm in case of malfunction: visual and acoustic
- Door alarm: visual and acoustic

Fridge and BioFresh compartments

- PowerCooling with FreshAir activated charcoal filter
- Comfort GlassLine storage shelves with bottle holder, adjustable egg tray, butter dish
- 2 Tiltable door shelves
- 2 Organisers for door shelf
- 4 GlassLine storage shelves
- Integrated bottle shelf
- LED ceiling lighting
- LED BioFresh lighting
- 2 BioFresh Safes with SoftTelescopic, 1 Fruit & Vegetable Safe, 1 Meat & Dairy Safe

Freezer compartment

- 4 drawers, VarioSpace
- IceMaker with fixed 3/4" water connection
- Ice cube production in 24 hrs: 1.2 kg
- Ice cube reservoir 6.0 kg
- LED lighting
- Temperature rise time: 14 h
- Freezing capacity in 24 hrs: 5 kg
- Right-hand freezer compartment can be used as a VarioTempZone

Key features

- Recessed handles
- Transport handles, front and at back, transport castors at back
- Height-adjustable feet at front and back
- Door hinge left fixed/right fixed
- Replaceable door seal
- Dry rear wall in BlackSteel

Colour / material options:

MBsddi 9024 with Stainless steel front

Available from fourth quarter of 2025

¹ To achieve the indicated energy consumption level, the wall spacers provided with the appliance must be used. These increase the appliance depth by approximately 1.0 cm. If the wall spacers are not used, the appliance will remain fully functional, but will have a slightly higher energy consumption level.



← 91 →

Msdd 9012
Pure

Energy efficiency class:	
Energy consumption year / 24 hrs:	273 / 0.747 kWh¹
Total volume ² :	576 l
Volume:	Fridge: 356.4 l / Freezer compartment: 220 l
Noise output / noise class:	39 dB(A) / C
Climate rating:	SN-ST (from +10°C to +38°C)
Door / side walls:	SmartSteel / silver
Exterior dimensions in cm (h / w / d):	180.5 / 90.6 / 74.5¹

Easy Fresh	Duo Cooling	No Frost	Super Cool	Super Frost	Vario Temp Zone	Easy Twist Ice	Flex Door System	Touch & Swipe Display
Vario Space	Smart Device Ready							

Controls

- 2.4" TFT-colour display behind-the-door, touch- & swipe
- Digital temperature display for fridge and freezer compartments
- SmartDeviceBox: optional accessory
- Alarm in case of malfunction: visual and acoustic
- Door alarm: visual and acoustic

Fridge compartment

- PowerCooling with FreshAir activated charcoal filter
- Comfort GlassLine storage shelves with bottle holder, adjustable egg tray, butter dish
- 2 Tiltable door shelves
- 2 Organisers for door shelf
- 5 GlassLine storage shelves
- 3-bottle shelf
- LED ceiling lighting
- 2 EasyFresh Safes on telescopic rails

Freezer compartment

- 4 drawers, VarioSpace
- EasyTwist-Ice
- LED lighting
- Temperature rise time: 14 h
- Freezing capacity in 24 hrs: 5 kg
- Right-hand freezer compartment can be used as a VarioTempZone

Key features

- Recessed handles
- Transport handles, front and at back, transport castors at back
- Height-adjustable feet at front and back
- Door hinge left fixed/right fixed
- Replaceable door seal

Available from fourth quarter of 2025



← 91 →

CBNste 8872

Energy efficiency class:	
Energy consumption year / 24 hrs:	328 / 0.898 kWh
Total volume ² :	522 l
Volume:	Fridge: 292.2 l / BioFresh compartment: 70.6 l / Freezer compartment: 160 l
Noise output / noise class:	42 dB(A) / D
Climate rating:	SN-T (from +10°C to +43°C)
Door / side walls:	Stainless steel / stainless steel
Exterior dimensions in cm (h / w / d):	202.7 / 91 / 62.5

Bio Fresh	Duo Cooling	No Frost	Super Cool	Super Frost	Light Tower	Ice Maker	Flex Door System
-----------	-------------	----------	------------	-------------	-------------	-----------	------------------

Controls

- MagicEye behind-the-door, touch electronic
- Digital temperature display for fridge and freezer compartments
- FrostControl
- Alarm in case of malfunction: visual and acoustic
- Door alarm: acoustic

Fridge and BioFresh compartments

- PowerCooling
- Premium GlassLine storage shelves with bottle holder
- 3 GlassLine storage shelves
- Integrated bottle shelf
- LED light column on both sides and LED ceiling lighting
- LED BioFresh lighting
- 2 BioFresh Safes on telescopic rails set variably to either HydroSafe or DrySafe

Freezer compartment

- 2 drawers on telescopic rails
- IceMaker with fixed 3/4" water connection
- Ice cube production in 24 hrs: 1.4 kg
- Ice cube reservoir 2.7 kg
- LED lighting
- Temperature rise time: 16.9 h
- Freezing capacity in 24 hrs: 10 kg

Key features

- Aluminium handles
- Versatile installation due to front ventilation
- Transport handles at back, transport castors at back
- Height-adjustable feet at front
- Door hinge left fixed/right fixed
- Replaceable door seal
- Dry rear wall in stainless steel with SmartSteel

² In accordance with Regulation EU 2019/2016 we indicate the total volume to the nearest integer (rounded off) and the volume of the frozen compartments and refrigeration compartments to one place after the decimal point. You can find the full range of efficiency classes at page 15. According to (EU) 2017/1369 6a.

Side-by-Side fridge-freezers





XRFsf 5245 ◇ Plus series

Quality in every detail



BioFresh with HydroBreeze

Do you want to cool fruit and vegetables like professionals? You'll be inspired by HydroBreeze. The cold mist combined with a temperature in the safe of around 0 °C gives food that extra boost for longer shelf life. And it creates a genuine visual wow effect. HydroBreeze is activated every 90 min. for 4 seconds and for 8 seconds when the door is opened.



EasyFresh

The guarantee of market freshness in the home is our EasyFresh Safe. Whether it's unpackaged vegetables or fruit, this ensures optimal storage for everything. Thanks to the air-tight closure, the food causes the humidity in the safe to rise. This keeps the food fresher for longer.



Fish & Seafood Safe

Love fish? Your Liebherr keeps fish fresh! The Fish & Seafood Safe stores fish and seafood at the optimum temperature of -2 °C; as professionally as your fishmonger. Adjust the size of the -2 °C zone as much as you want – and store the remaining meat and dairy products at the optimum 0 °C. An LED display indicates that the -2 °C zone is currently active.



DuoCooling

DuoCooling uses two completely separate refrigeration circuits to ensure no air is exchanged between the fridge and freezer compartments. The food stays fresh without drying out, and odours are not transferred. This means throwing less away, shopping less often, but saving more and greater enjoyment.



PowerCooling

Do you want to be sure that the cold is distributed as evenly as possible in your refrigerator? If so, the PowerCooling system is what you need. The fan – as powerful as it is quiet – distributes the cold air efficiently throughout the entire refrigeration compartment.



Touch & Swipe display

Control of your Liebherr at your fingertips: thanks to the Touch & Swipe display, you can operate your refrigerator intuitively and with ease. Simply select functions such as SuperCool on the colour display by tapping and swiping. The temperature is controlled just as easily. And, what if you are not actively using the display? It then shows you the actual temperature.



NoFrost

When you open your freezer, you want to see frozen food – and certainly not ice and frost. NoFrost protects the freezer compartment from unwanted icing, which consumes a lot of energy and can be expensive. NoFrost means no more tedious and time-consuming defrosting of the freezer compartment, more time for other things – and saving money.



LED freezer compartment lighting

When you open the drawers in your Liebherr freezer, not only are you welcomed by the sight of your food, but also by the attractive lighting. This is provided by powerful, long-life, environmentally-friendly LEDs. The lighting makes it even easier to see all of the contents and is also a unique design element.



Bottle shelf above the BioFresh Safe

Expecting guests and want to chill a few more drinks than usual? The bottle shelf above the BioFresh Safes exists for this very reason. Simply remove the glass shelf above the bottle shelf in one easy step – and you can now safely store and cool bottles of various sizes.



SoftSystem

From breakfast to a midnight snack – a fridge needs to be open and closed on many occasions. And your Liebherr makes this a lot of fun. With the SoftSystem, your fridge door closes softly and safely, and in a way which is pleasantly quiet and light. Bottles stored in the inside door remain securely in place – nothing rattles or wobbles.

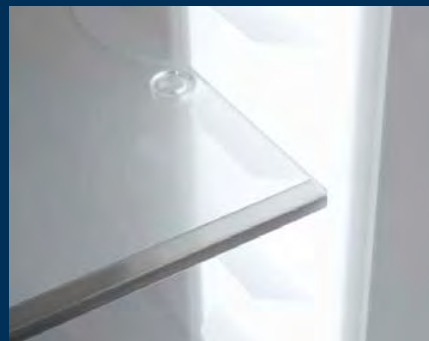

LightTower

Enjoy an optimally illuminated interior: the LightTower shows off the food in its best light and is positioned so that all of your filled fridge is illuminated at all times. The flush mounting of the LightTower in the side walls means there is also more space for your food.

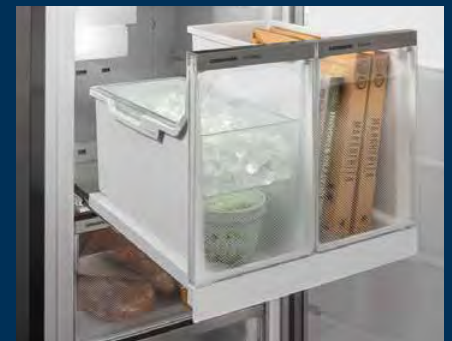

IceTower

You will never run out of cold drinks at your party. The IceTower, which holds 8 kg of ice cubes, makes sure of that. The ice cube scoop and the pull-out tray on telescopic rails allow easy access to the ice cubes. An extra insert tray means you can also store less ice and make room for frozen food underneath. The adjacent drawer provides storage space for frozen goods.



XRCbs 5295 Δ Peak series

¹ To achieve the indicated energy consumption level, the wall spacers provided with the appliance must be used. These increase the appliance depth by approximately 1.5 cm. If the wall spacers are not used, the appliance will remain fully functional, but will have a slightly higher energy consumption level.



←121→

XRCbs 5295

Peak



SWNbsd 529i

Energy efficiency class:	D
Energy consumption year / 24 hrs:	190 / 0.520 kWh¹
Total volume ² :	303 l
Volume:	Wine compartment: 171.1 l / Freezer compartment: 133 l
Noise output / noise class:	36 dB(A) / C
Climate rating:	SN-T (from +10 °C to +43 °C)
Door / side walls:	BlackSteel / BlackSteel
Exterior dimensions in cm (h / w / d):	185.5 / 59.7 / 67.5¹



Controls

- 2.4" TFT-colour display behind-the-door, touch- & swipe
- Digital temperature display for wine and freezer compartments
- SmartDeviceBox included
- Alarm in case of malfunction: visual and acoustic
- Door alarm: visual and acoustic

Freezer compartment ********

- 4 drawers, of which 3 with telescopic partial pull-out, VarioSpace
- IceMaker with fixed 3/4" water connection, LED lighting
- Ice cube production in 24 hrs: 1.2 kg
- Ice cube reservoir 5.4 kg
- LED lighting
- Temperature rise time: 20 h
- Freezing capacity in 24 hrs: 10 kg
- Safety glass fittings

Wine compartment

- 3 temperature zones, which can set from +5 °C to +20 °C
- 3 independently controllable zones
- Convection cooling, fresh air supply via FreshAir activated charcoal filter
- Humidity regulation via adjustable fan
- LED light panel, both sides
- 6 shelves, of which 4 set on telescopic rails

Key features

- Side wall heating right, suitable for combination with other refrigerators, freezers and/or wine appliances
- Slimline handles with integrated opening mechanism in BlackSteel-Look
- Transport handles, front and at back, transport castors at back
- Height-adjustable feet at front
- Reversible door hinge, left
- Replaceable door seal
- Dry rear wall in BlackSteel

SRBbsc 529i

Energy efficiency class:	C
Energy consumption year / 24 hrs:	108 / 0.295 kWh¹
Total volume ² :	386 l
Volume:	Fridge: 246.2 l / BioFresh compartment: 140.6 l
Noise output / noise class:	34 dB(A) / B, SuperSilent
Climate rating:	SN-T (from +10 °C to +43 °C)
Door / side walls:	BlackSteel / BlackSteel
Exterior dimensions in cm (h / w / d):	185.5 / 59.7 / 67.5¹



Controls

- 2.4" TFT-colour display behind-the-door, touch- & swipe
- Digital temperature display for fridge and BioFresh compartments
- SmartDeviceBox included
- Door alarm: visual and acoustic

Fridge and BioFresh compartments

- PowerCooling with Ambilight and FreshAir activated charcoal filter
- Premium GlassLine storage shelves with bottle holder, removable VarioBoxes, adjustable egg tray, butter dish
- 4 GlassLine storage shelves, of which 1 is divided into two parts
- VarioSafe
- Integrated bottle shelf
- LED light panel, both sides
- LED BioFresh lighting
- 3 BioFresh Safes with SoftTelescopic, 2 Fruit & Vegetable Safes, of which 1 with HydroBreeze, 1 Meat & Dairy Safe, 1 FlexSystem
- InfinitySpring with fixed 3/4" water connection

Key features

- Side wall heating left, suitable for combination with other refrigerators, freezers and/or wine appliances
- Slimline handle with integrated opening mechanism in BlackSteel-Look
- Transport handles, front and at back, transport castors at back
- Height-adjustable feet at front
- Reversible door hinging, right
- Replaceable door seal
- Dry rear wall and door panel in BlackSteel

Colour / material options:
XRCst 5295 in SmartSteel

² In accordance with Regulation EU 2019/2016 we indicate the total volume to the nearest integer (rounded off) and the volume of the frozen compartments and refrigeration compartments to one place after the decimal point. You can find the full range of efficiency classes at page 15. According to (EU) 2017/1369 6a.

Side-by-Side fridge-freezers



XRFbs 5295

Peak



SFNbsd 529i

Energy efficiency class:	
Energy consumption year / 24 hrs:	199 / 0.545 kWh ¹
Total volume ² :	277 l
Noise output / noise class:	34 dB(A) / B, SuperSilent
Climate rating:	SN-T (from +10 °C to +43 °C)
Door / side walls:	BlackSteel / BlackSteel
Exterior dimensions in cm (h / w / d):	185.5 / 59.7 / 67.5 ¹

No Frost	Super Frost	LED	Ice Tower	Soft System	Telescopic Rails	Super Silent	Touch & Swipe Display	Space Box
Vario Space	Easy Open	Smart Device						

Controls

- 2.4" TFT-colour display behind-the-door, touch- & swipe
- Digital temperature display
- SmartDeviceBox included
- Alarm in case of malfunction: visual and acoustic
- Door alarm: visual and acoustic

Freezer compartment

- 7 drawers, of which 4 with telescopic partial pull-out, VarioSpace
- Top drawer with convenient tilting function
- IceTower
- IceMaker with fixed 3/4" water connection, LED lighting
- Ice cube production in 24 hrs: 0.8 kg
- Ice cube reservoir 8.0 kg
- LED lighting
- Temperature rise time: 16 h
- Freezing capacity in 24 hrs: 18 kg
- 1 cold storage accumulator
- Safety glass fittings

Key features

- Side wall heating right, suitable for combination with other refrigerators, freezers and/or wine appliances
- Slimline handle with integrated opening mechanism in BlackSteel-Look
- Transport handles, front and at back, transport castors at back
- Height-adjustable feet at front
- Reversible door hinge, left
- Replaceable door seal
- Trim strips in BlackSteel

SRBbsc 529i

Energy efficiency class:	
Energy consumption year / 24 hrs:	108 / 0.295 kWh ¹
Total volume ² :	386 l
Volume:	Fridge: 246.2 l / BioFresh compartment: 140.6 l
Noise output / noise class:	34 dB(A) / B, SuperSilent
Climate rating:	SN-T (from +10 °C to +43 °C)
Door / side walls:	BlackSteel / BlackSteel
Exterior dimensions in cm (h / w / d):	185.5 / 59.7 / 67.5 ¹

Bio Fresh Professional	Hydro Breeze	Super Cool	Glass & Steel Interior	Light Tower	Infinity Spring	Soft System	Soft-Telescopic Rails	Super Silent
Touch & Swipe Display	Smart Device							

Controls

- 2.4" TFT-colour display behind-the-door, touch- & swipe
- Digital temperature display for fridge and BioFresh compartments
- SmartDeviceBox included
- Door alarm: visual and acoustic

Fridge and BioFresh compartments

- PowerCooling with Ambilight and FreshAir activated charcoal filter
- Premium GlassLine storage shelves with bottle holder, removable VarioBoxes, adjustable egg tray, butter dish
- 4 GlassLine storage shelves, of which 1 is divided into two parts
- VarioSafe
- Integrated bottle shelf
- LED light panel, both sides
- LED BioFresh lighting
- 3 BioFresh Safes with SoftTelescopic, 2 Fruit & Vegetable Safes, of which 1 with HydroBreeze, 1 Meat & Dairy Safe
- InfinitySpring with fixed 3/4" water connection

Key features

- Side wall heating left, suitable for combination with other refrigerators, freezers and/or wine appliances
- Slimline handle with integrated opening mechanism in BlackSteel-Look
- Transport handles, front and at back, transport castors at back
- Height-adjustable feet at front
- Reversible door hinging, right
- Replaceable door seal
- Dry rear wall and door panel in BlackSteel

¹ To achieve the indicated energy consumption level, the wall spacers provided with the appliance must be used. These increase the appliance depth by approximately 1.5 cm. If the wall spacers are not used, the appliance will remain fully functional, but will have a slightly higher energy consumption level.



XRFst 5295

Peak



SFNstd 529i

Energy efficiency class:	D
Energy consumption year / 24 hrs:	199 / 0.545 kWh¹
Total volume ² :	277 l
Noise output / noise class:	34 dB(A) / B, SuperSilent
Climate rating:	SN-T (from +10 °C to +43 °C)
Door / side walls:	SmartSteel / SmartSteel
Exterior dimensions in cm (h / w / d):	185.5 / 59.7 / 67.5¹

No Frost	Super Frost	LED	Ice Tower	Soft System	Telescopic Rails	Super Silent	Touch & Swipe Display	Space Box
Vario Space	Easy Open	Smart Device						

Controls

- 2.4" TFT-colour display behind-the-door, touch- & swipe
- Digital temperature display
- SmartDeviceBox included
- Alarm in case of malfunction: visual and acoustic
- Door alarm: visual and acoustic

Freezer compartment ********

- 7 drawers, of which 4 with telescopic partial pull-out, VarioSpace
- Top drawer with convenient tilting function
- IceTower
- IceMaker with fixed 3/4" water connection, LED lighting
- Ice cube production in 24 hrs: 0.8 kg
- Ice cube reservoir 8.0 kg
- LED lighting
- Temperature rise time: 16 h
- Freezing capacity in 24 hrs: 18 kg
- 1 cold storage accumulator
- Safety glass fittings

Key features

- Side wall heating right, suitable for combination with other refrigerators, freezers and/or wine appliances
- Slimline handle with integrated opening mechanism
- Transport handles, front and at back, transport castors at back
- Height-adjustable feet at front
- Reversible door hinge, left
- Replaceable door seal

SRBstc 529i

Energy efficiency class:	C
Energy consumption year / 24 hrs:	108 / 0.295 kWh¹
Total volume ² :	386 l
Volume:	Fridge: 246.2 l / BioFresh compartment: 140.6 l
Noise output / noise class:	34 dB(A) / B, SuperSilent
Climate rating:	SN-T (from +10 °C to +43 °C)
Door / side walls:	SmartSteel / SmartSteel
Exterior dimensions in cm (h / w / d):	185.5 / 59.7 / 67.5¹

Bio Fresh Professional	Hydro Breeze	Super Cool	Glass & Steel Interior	Light Tower	Infinity Spring	Soft System	Soft-Telescopic Rails	Super Silent
Touch & Swipe Display	Smart Device							

Controls

- 2.4" TFT-colour display behind-the-door, touch- & swipe
- Digital temperature display for fridge and BioFresh compartments
- SmartDeviceBox included
- Door alarm: visual and acoustic

Fridge and BioFresh compartments

- PowerCooling with Ambilight and FreshAir activated charcoal filter
- Premium GlassLine storage shelves with bottle holder, removable VarioBoxes, adjustable egg tray, butter dish
- 4 GlassLine storage shelves, of which 1 is divided into two parts
- VarioSafe
- Integrated bottle shelf
- LED light panel, both sides
- LED BioFresh lighting
- 3 BioFresh Safes with SoftTelescopic, 2 Fruit & Vegetable Safes, of which 1 with HydroBreeze, 1 Meat & Dairy Safe, 1 FlexSystem
- InfinitySpring with fixed 3/4" water connection

Key features

- Side wall heating left, suitable for combination with other refrigerators, freezers and/or wine appliances
- Slimline handle with integrated opening mechanism
- Transport handles, front and at back, transport castors at back
- Height-adjustable feet at front
- Reversible door hinging, right
- Replaceable door seal
- Dry rear wall and door panel in stainless steel with SmartSteel

² In accordance with Regulation EU 2019/2016 we indicate the total volume to the nearest integer (rounded off) and the volume of the frozen compartments and refrigeration compartments to one place after the decimal point. You can find the full range of efficiency classes at page 15. According to (EU) 2017/1369 6a.

Side-by-Side fridge-freezers



←121→

XRCsd 5255

Prime



SBNsdd 526i

Energy efficiency class:	D ^A / _G ¹
Energy consumption year / 24 hrs:	171 / 0.468 kWh ¹
Total volume ² :	313 l
Volume:	BioFresh compartment: 180.7 l / Freezer compartment: 133 l
Noise output / noise class:	34 dB(A) / B, SuperSilent
Climate rating:	SN-T (from +10 °C to +43 °C)
Door / side walls:	SmartSteel / silver
Exterior dimensions in cm (h / w / d):	185.5 / 59.7 / 67.5 ¹

Bio Fresh	No Frost	Super Frost	Vario Temp	Glass & Steel Interior	Ice Maker	Soft System	Soft-Telescopic Rails	Super Silent
Touch & Swipe Display	Vario Space	Smart Device						

Controls

- 2.4" TFT-colour display behind-the-door, touch- & swipe
- Digital temperature display for BioFresh and freezer compartments
- SmartDeviceBox included
- Alarm in case of malfunction: visual and acoustic
- Door alarm: visual and acoustic

Fridge and BioFresh compartments

- PowerCooling with FreshAir activated charcoal filter
- Premium GlassLine storage shelves with bottle holder, removable VarioBoxes
- 1 GlassLine storage shelf, of which 1 is divided into two parts
- Integrated bottle shelf
- LED ceiling lighting
- LED BioFresh lighting
- 2 BioFresh Safes with SoftTelescopic, 2 Fruit & Vegetable Safes

Freezer compartment *******

- 4 drawers, VarioSpace
- IceMaker with fixed 3/4" water connection
- Ice cube production in 24 hrs: 1.2 kg
- Ice cube reservoir 5.4 kg
- LED lighting
- Temperature rise time: 20 h
- Freezing capacity in 24 hrs: 10 kg
- Safety glass fittings

Key features

- Side wall heating right, suitable for combination with other refrigerators, freezers and/or wine appliances
- Slimline handles with integrated opening mechanism
- Transport handles, front and at back, transport castors at back
- Height-adjustable feet at front
- Reversible door hinge, left
- Replaceable door seal
- Dry rear wall in stainless steel with SmartSteel

SRsdc 525i

Energy efficiency class:	C ^A / _G ¹
Energy consumption year / 24 hrs:	79 / 0.216 kWh ¹
Total volume ² :	401 l
Noise output / noise class:	35 dB(A) / B, SuperSilent
Climate rating:	SN-T (from +10 °C to +43 °C)
Door / side walls:	SmartSteel / silver
Exterior dimensions in cm (h / w / d):	185.5 / 59.7 / 67.5 ¹

Easy Fresh	Super Cool	Glass & Steel Interior	Light Tower	Soft System	Super Silent	Touch & Swipe Display	Smart Device
------------	------------	------------------------	-------------	-------------	--------------	-----------------------	--------------

Controls

- 2.4" TFT-colour display behind-the-door, touch- & swipe
- Digital temperature display
- SmartDeviceBox included
- Door alarm: visual and acoustic

Fridge compartment

- PowerCooling with FreshAir activated charcoal filter
- Premium GlassLine storage shelves with bottle holder, removable VarioBoxes, adjustable egg tray, butter dish
- 6 GlassLine storage shelves, of which 1 is divided into two parts
- VarioSafe
- Bottle shelf
- LED light panel, both sides
- 1 EasyFresh Safe on telescopic rails

Key features

- Side wall heating left, suitable for combination with other refrigerators, freezers and/or wine appliances
- Slimline handle with integrated opening mechanism
- Transport handles, front and at back, transport castors at back
- Height-adjustable feet at front
- Reversible door hinging, right
- Replaceable door seal
- Dry rear wall in stainless steel with SmartSteel

¹ To achieve the indicated energy consumption level, the wall spacers provided with the appliance must be used. These increase the appliance depth by approximately 1.5 cm. If the wall spacers are not used, the appliance will remain fully functional, but will have a slightly higher energy consumption level.



←121→



XCCsd 5250

Prime

SCNsd 525i 617

Energy efficiency class:	
Energy consumption year / 24 hrs:	161 / 0.441 kWh ¹
Total volume ² :	331 l
Volume:	Fridge: 228.7 l / Freezer compartment: 103 l
Noise output / noise class:	34 dB(A) / B, SuperSilent
Climate rating:	SN-T (from +10°C to +43°C)
Door / side walls:	SmartSteel / silver
Exterior dimensions in cm (h / w / d):	185.5 / 59.7 / 67.5 ¹

Easy Fresh	No Frost	Super Cool	Super Frost	Vario Temp	Glass & Steel Interior	Light Tower	Soft System	Super Silent
Touch & Swipe Display	Vario Space	Smart Device						

Controls

- 2.4" TFT-colour display behind-the-door, touch- & swipe
- Digital temperature display for fridge and freezer compartments
- SmartDeviceBox included
- Alarm in case of malfunction: visual and acoustic
- Door alarm: visual and acoustic

Fridge compartment

- PowerCooling with FreshAir activated charcoal filter
- Premium GlassLine storage shelves with bottle holder, removable VarioBoxes, adjustable egg tray, butter dish
- 4 GlassLine storage shelves, of which 1 is divided into two parts
- VarioSafe
- Bottle shelf
- LED light panel, both sides
- 1 EasyFresh Safe on telescopic rails

Freezer compartment

- 3 drawers, VarioSpace
- Ice cube tray with lid
- LED lighting
- Temperature rise time: 20 h
- Freezing capacity in 24 hrs: 10 kg
- Safety glass fittings

Key features

- Side wall heating right, suitable for combination with other refrigerators, freezers and/or wine appliances
- Slimline handles with integrated opening mechanism
- Transport handles, front and at back, transport castors at back
- Height-adjustable feet at front
- Reversible door hinge, left
- Replaceable door seal
- Dry rear wall in stainless steel with SmartSteel

SCNsd 525i

Energy efficiency class:	
Energy consumption year / 24 hrs:	161 / 0.441 kWh ¹
Total volume ² :	331 l
Volume:	Fridge: 228.7 l / Freezer compartment: 103 l
Noise output / noise class:	34 dB(A) / B, SuperSilent
Climate rating:	SN-T (from +10°C to +43°C)
Door / side walls:	SmartSteel / silver
Exterior dimensions in cm (h / w / d):	185.5 / 59.7 / 67.5 ¹

Easy Fresh	No Frost	Super Cool	Super Frost	Vario Temp	Glass & Steel Interior	Light Tower	Soft System	Super Silent
Touch & Swipe Display	Vario Space	Smart Device						

Controls

- 2.4" TFT-colour display behind-the-door, touch- & swipe
- Digital temperature display for fridge and freezer compartments
- SmartDeviceBox included
- Alarm in case of malfunction: visual and acoustic
- Door alarm: visual and acoustic

Fridge compartment

- PowerCooling with FreshAir activated charcoal filter
- Premium GlassLine storage shelves with bottle holder, removable VarioBoxes, adjustable egg tray, butter dish
- 4 GlassLine storage shelves, of which 1 is divided into two parts
- VarioSafe
- Bottle shelf
- LED light panel, both sides
- 1 EasyFresh Safe on telescopic rails

Freezer compartment

- 3 drawers, VarioSpace
- Ice cube tray with lid
- LED lighting
- Temperature rise time: 20 h
- Freezing capacity in 24 hrs: 10 kg
- Safety glass fittings

Key features

- Side wall heating left, suitable for combination with other refrigerators, freezers and/or wine appliances
- Slimline handles with integrated opening mechanism
- Transport handles, front and at back, transport castors at back
- Height-adjustable feet at front
- Reversible door hinging, right
- Replaceable door seal
- Dry rear wall in stainless steel with SmartSteel

² In accordance with Regulation EU 2019/2016 we indicate the total volume to the nearest integer (rounded off) and the volume of the frozen compartments and refrigeration compartments to one place after the decimal point. You can find the full range of efficiency classes at page 15. According to (EU) 2017/1369 6a.

Side-by-Side fridge-freezers



←123→

XRFsf 5245

Plus



SFNsf 5247

Energy efficiency class:	
Energy consumption year / 24 hrs:	199 / 0.545 kWh ¹
Total volume ² :	277 l
Noise output / noise class:	36 dB(A) / C
Climate rating:	SN-T (from +10 °C to +43 °C)
Door / side walls:	SteelFinish / silver
Exterior dimensions in cm (h / w / d):	185.5 / 59.7 / 67.5 ¹



Controls

- LC monochrome display behind-the-door, touch electronic
- Digital temperature display
- SmartDeviceBox: optional accessory
- Alarm in case of malfunction: visual and acoustic
- Door alarm: visual and acoustic

Freezer compartment

- 7 drawers on integrated drawer guide, VarioSpace
- Top drawer with convenient tilting function
- IceTower
- IceMaker with fixed 3/4" water connection
- Ice cube production in 24 hrs: 0.8 kg
- Ice cube reservoir 8.0 kg
- Temperature rise time: 16 h
- Freezing capacity in 24 hrs: 18 kg

Key features

- Side wall heating right, suitable for combination with other refrigerators, freezers and/or wine appliances
- Vertical recessed handle
- Transport handles, front and at back, transport castors at back
- Height-adjustable feet at front
- Reversible door hinge, left
- Replaceable door seal

SRBsf 5220

Energy efficiency class:	
Energy consumption year / 24 hrs:	101 / 0.276 kWh ¹
Total volume ² :	382 l
Volume:	Fridge: 288.7 l / BioFresh compartment: 93.7 l
Noise output / noise class:	34 dB(A) / B, SuperSilent
Climate rating:	SN-T (from +10 °C to +43 °C)
Door / side walls:	SteelFinish / silver
Exterior dimensions in cm (h / w / d):	185.5 / 59.7 / 67.5 ¹

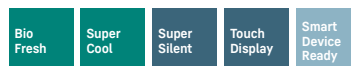

Controls

- LC monochrome display behind-the-door, touch electronic
- Digital temperature display for fridge compartment
- SmartDeviceBox: optional accessory
- Door alarm: visual and acoustic

Fridge and BioFresh compartments

- PowerCooling with FreshAir activated charcoal filter
- Plastic door shelves with bottle holder, egg tray, FlexCube
- 6 GlassLine storage shelves, of which 1 is divided into two parts
- VarioSafe
- Integrated bottle shelf
- LED ceiling lighting
- 2 BioFresh Safes with telescopic partial pull-out, 1 Fruit & Vegetable Safe, 1 Meat & Dairy Safe

Key features

- Side wall heating left, suitable for combination with other refrigerators, freezers and/or wine appliances
- Vertical recessed handle
- Transport handles, front and at back, transport castors at back
- Height-adjustable feet at front
- Reversible door hinging, right
- Replaceable door seal

Colour / material options:

XRFsf 5240 without BioFresh

¹ To achieve the indicated energy consumption level, the wall spacers provided with the appliance must be used. These increase the appliance depth by approximately 1.5 cm. If the wall spacers are not used, the appliance will remain fully functional, but will have a slightly higher energy consumption level.



←123→

XRFsf 5225

Plus



SFNsf 5227

Energy efficiency class:	
Energy consumption year / 24 hrs:	199 / 0.545 kWh ¹
Total volume ² :	277 l
Noise output / noise class:	36 dB(A) / C
Climate rating:	SN-T (from +10 °C to +43 °C)
Designed to operate in ambient temperatures:	as low as -15 °C
Door / side walls:	SteelFinish / silver
Exterior dimensions in cm (h / w / d):	185.5 / 59.7 / 67.5 ¹



Controls

- LC monochrome display behind-the-door, touch electronic
- Digital temperature display
- SmartDeviceBox: optional accessory
- Alarm in case of malfunction: visual and acoustic
- Door alarm: visual and acoustic

Freezer compartment

- 7 drawers on integrated drawer guide, VarioSpace
- Top drawer with convenient tilting function
- Ice cube tray
- Temperature rise time: 16 h
- Freezing capacity in 24 hrs: 18 kg

Key features

- Side wall heating right, suitable for combination with other refrigerators, freezers and/or wine appliances
- Vertical recessed handle
- Transport handles, front and at back, transport castors at back
- Height-adjustable feet at front
- Reversible door hinge, left
- Replaceable door seal

SRBsf 5220

Energy efficiency class:	
Energy consumption year / 24 hrs:	101 / 0.276 kWh ¹
Total volume ² :	382 l
Volume:	Fridge: 288.7 l / BioFresh compartment: 93.7 l
Noise output / noise class:	34 dB(A) / B, SuperSilent
Climate rating:	SN-T (from +10 °C to +43 °C)
Door / side walls:	SteelFinish / silver
Exterior dimensions in cm (h / w / d):	185.5 / 59.7 / 67.5 ¹



Controls

- LC monochrome display behind-the-door, touch electronic
- Digital temperature display for fridge compartment
- SmartDeviceBox: optional accessory
- Door alarm: visual and acoustic

Fridge and BioFresh compartments

- PowerCooling with FreshAir activated charcoal filter
- Plastic door shelves with bottle holder, egg tray, FlexCube
- 6 GlassLine storage shelves, of which 1 is divided into two parts
- VarioSafe
- Integrated bottle shelf
- LED ceiling lighting
- 2 BioFresh Safes with telescopic partial pull-out, 1 Fruit & Vegetable Safe, 1 Meat & Dairy Safe

Key features

- Side wall heating left, suitable for combination with other refrigerators, freezers and/or wine appliances
- Vertical recessed handle
- Transport handles, front and at back, transport castors at back
- Height-adjustable feet at front
- Reversible door hinging, right
- Replaceable door seal

² In accordance with Regulation EU 2019/2016 we indicate the total volume to the nearest integer (rounded off) and the volume of the frozen compartments and refrigeration compartments to one place after the decimal point. You can find the full range of efficiency classes at page 15. According to (EU) 2017/1369 6a.

Side-by-Side fridge-freezers



←123→

XRFsf 5220

Plus



SFNsf 5227

Energy efficiency class:	
Energy consumption year / 24 hrs:	199 / 0.545 kWh ¹
Total volume ² :	277 l
Noise output / noise class:	36 dB(A) / C
Climate rating:	SN-T (from +10 °C to +43 °C)
Designed to operate in ambient temperatures:	as low as -15 °C
Door / side walls:	SteelFinish / silver
Exterior dimensions in cm (h / w / d):	185.5 / 59.7 / 67.5 ¹



Controls

- LC monochrome display behind-the-door, touch electronic
- Digital temperature display
- SmartDeviceBox: optional accessory
- Alarm in case of malfunction: visual and acoustic
- Door alarm: visual and acoustic

Freezer compartment

- 7 drawers on integrated drawer guide, VarioSpace
- Top drawer with convenient tilting function
- Ice cube tray
- Temperature rise time: 16 h
- Freezing capacity in 24 hrs: 18 kg

Key features

- Side wall heating right, suitable for combination with other refrigerators, freezers and/or wine appliances
- Vertical recessed handle
- Transport handles, front and at back, transport castors at back
- Height-adjustable feet at front
- Reversible door hinge, left
- Replaceable door seal

SRsf 5220

Energy efficiency class:	
Energy consumption year / 24 hrs:	98 / 0.268 kWh ¹
Total volume ² :	399 l
Noise output / noise class:	35 dB(A) / B, SuperSilent
Climate rating:	SN-T (from +10 °C to +43 °C)
Door / side walls:	SteelFinish / silver
Exterior dimensions in cm (h / w / d):	185.5 / 59.7 / 67.5 ¹



Controls

- LC monochrome display behind-the-door, touch electronic
- Digital temperature display
- SmartDeviceBox: optional accessory
- Door alarm: visual and acoustic

Fridge compartment

- PowerCooling with FreshAir activated charcoal filter
- Plastic door shelves with bottle holder, egg tray, FlexCube
- 6 GlassLine storage shelves, of which 1 is divided into two parts
- VarioSafe
- Bottle shelf
- LED ceiling lighting
- 1 EasyFresh Safe on running rails

Key features

- Side wall heating left, suitable for combination with other refrigerators, freezers and/or wine appliances
- Vertical recessed handle
- Transport handles, front and at back, transport castors at back
- Height-adjustable feet at front
- Reversible door hinging, right
- Replaceable door seal

Colour / material options:

XRFbd 5220 in BlackSteel

¹ To achieve the indicated energy consumption level, the wall spacers provided with the appliance must be used. These increase the appliance depth by approximately 1.5 cm. If the wall spacers are not used, the appliance will remain fully functional, but will have a slightly higher energy consumption level.



←123→

XRF 5220

Plus



SFNd 5227

Energy efficiency class:	
Energy consumption year / 24 hrs:	199 / 0.545 kWh ¹
Total volume ² :	277 l
Noise output / noise class:	36 dB(A) / C
Climate rating:	SN-T (from +10 °C to +43 °C)
Designed to operate in ambient temperatures:	as low as -15 °C
Door / side walls:	white / white
Exterior dimensions in cm (h / w / d):	185.5 / 59.7 / 67.5 ¹



Controls

- LC monochrome display behind-the-door, touch electronic
- Digital temperature display
- SmartDeviceBox: optional accessory
- Alarm in case of malfunction: visual and acoustic
- Door alarm: visual and acoustic

Freezer compartment

- 7 drawers on integrated drawer guide, VarioSpace
- Top drawer with convenient tilting function
- Ice cube tray
- Temperature rise time: 16 h
- Freezing capacity in 24 hrs: 18 kg

Key features

- Side wall heating right, suitable for combination with other refrigerators, freezers and/or wine appliances
- Vertical recessed handle
- Transport handles, front and at back, transport castors at back
- Height-adjustable feet at front
- Reversible door hinge, left
- Replaceable door seal

SRd 5220

Energy efficiency class:	
Energy consumption year / 24 hrs:	98 / 0.268 kWh ¹
Total volume ² :	399 l
Noise output / noise class:	35 dB(A) / B, SuperSilent
Climate rating:	SN-T (from +10 °C to +43 °C)
Door / side walls:	white / white
Exterior dimensions in cm (h / w / d):	185.5 / 59.7 / 67.5 ¹



Controls

- LC monochrome display behind-the-door, touch electronic
- Digital temperature display
- SmartDeviceBox: optional accessory
- Door alarm: visual and acoustic

Fridge compartment

- PowerCooling with FreshAir activated charcoal filter
- Plastic door shelves with bottle holder, egg tray, FlexCube
- 6 GlassLine storage shelves, of which 1 is divided into two parts
- VarioSafe
- Bottle shelf
- LED ceiling lighting
- 1 EasyFresh Safe on running rails

Key features

- Side wall heating left, suitable for combination with other refrigerators, freezers and/or wine appliances
- Vertical recessed handle
- Transport handles, front and at back, transport castors at back
- Height-adjustable feet at front
- Reversible door hinging, right
- Replaceable door seal

Fridge-freezers





CBNbda 572i ◆ Plus series



CBNsda 575i ◯ Prime series

Range overview by appliance height and series

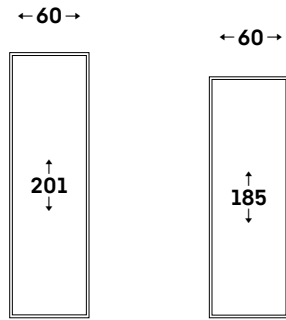

- △ Peak series
- Prime series
- ◇ Plus series
- Pure series

Fridge-freezers – BioFresh Professional

NoFrost		
HydroBreeze/IceMaker/VarioTemp	CBNstb 579i	

Fridge-freezers – BioFresh

NoFrost		
EasyTwist-Ice/VarioTemp	CBNsda 575i	
EasyTwist-Ice	CBNbda 572i	CBNbda 5223
	CBNsda 572i	CBNsda 5223
	CBNa 572i	CBNsfc 5223
	CBNsfc 57vi	CBNc 5223
	CBNc 5723	
	CBNbdc 573i	

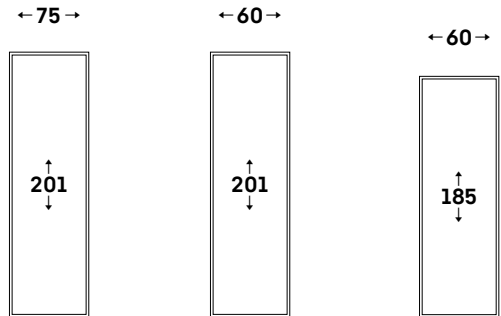

Fridge-freezers – EasyFresh

NoFrost			
IceMaker	CNsdd 776i		
EasyTwist-Ice	CNsfa 7723	CNc 5724	CNsdb 5223
		CNsda 5723	
		CNbda 5723	
		CNsfd 5704	CNsfd 5204
		CNsfd 5703	CNd 5204
		CNd 5703	CNd 5203
			CNsfd 5203

Fridge-freezers



○ Pure series



◇ Plus series



◻ Prime series



△ Peak series

	○ Pure series	◇ Plus series	◻ Prime series	△ Peak series
Freshness technology	EasyFresh on integrated drawer guide	EasyFresh on integrated drawer guide	EasyFresh on telescopic rails	EasyFresh on telescopic rails
		BioFresh on telescopic rails	BioFresh with SoftTelescopic	BioFresh Professional with SoftTelescopic
				HydroBreeze
				Fish & Seafood Safe
	DuoCooling	DuoCooling	DuoCooling	DuoCooling
	FreshAir filter	FreshAir filter	FreshAir filter	FreshAir filter
			VarioTemp	VarioTemp
	NoFrost	NoFrost	NoFrost	NoFrost on telescopic rails
Comfort and flexibility		Divisible glass shelf	Divisible glass shelf	Divisible glass shelf
			SoftSystem soft closing mechanism	SoftSystem soft closing mechanism
		VarioSafe	VarioSafe	VarioSafe
			VarioBoxes	VarioBoxes
			Butter dish	Butter dish
	Egg tray	Egg tray	Adjustable egg tray	Adjustable egg tray
	Bottle shelf	Bottle shelf	Bottle shelf	Bottle shelf
		Ice cube tray	Ice cube tray with lid	Ice cube tray with lid
				FlexSystem
Design	Ceiling lighting fridge compartment	Ceiling lighting fridge compartment	LightTower	LightTower
			Lighting BioFresh Safe	Lighting BioFresh Safe
			Freezer compartment lighting	Freezer compartment lighting
				IceMaker lighting
				Fan lighting
			SmartSteel rear wall	SmartSteel rear wall
				SmartSteel door interior
	Transparent glass	Transparent glass	Satin finish glass	Satin finish glass
	Stainless steel look shelves	Stainless steel look shelves	Glass & stainless steel rack	Glass & stainless steel rack
	Touch display	Touch display	Touch & Swipe display	Touch & Swipe display
	Display behind the door	Display behind the door or Display in the door	Display behind the door or Display in the door	Display behind the door or Display in the door
	Recessed handles	Recessed handles	Slimline door handles with opening mechanism	Recessed handles
Connectivity (SmartDeviceBox)	Can be retrofitted	Can be retrofitted or is included with "i" models	Can be retrofitted or is included with "i" models	Can be retrofitted or is included with "i" models
Water and ice		IceMaker or EasyTwist-Ice	IceMaker or EasyTwist-Ice	IceMaker
				InfinitySpring

Differentiating equipment is **highlighted** in the next higher series.

Quality in every detail



BioFresh with HydroBreeze

Do you want to cool fruit and vegetables like professionals? You'll be inspired by HydroBreeze. The cold mist combined with a temperature in the safe of around 0 °C gives food that extra boost for longer shelf life. And it creates a genuine visual wow effect. HydroBreeze is activated every 90 min. for 4 seconds and for 8 seconds when the door is opened.



EasyFresh

The guarantee of market freshness in the home is our EasyFresh Safe. Whether it's unpackaged vegetables or fruit, this ensures optimal storage for everything. Thanks to the air-tight closure, the food causes the humidity in the safe to rise. This keeps the food fresh for a long time.



Fish & Seafood Safe

Love fish? Your Liebherr keeps fish fresh! The Fish & Seafood Safe stores fish and seafood at the optimum temperature of -2 °C; as professionally as your fishmonger. Adjust the size of the -2 °C zone as much as you want – and store the remaining meat and dairy products at the optimum 0 °C. An LED display indicates that the -2 °C zone is currently active.



InfinitySpring

A source of fresh, cool drinking water in your kitchen. InfinitySpring sounds like something from a fairy tale. The water dispenser enables drip-free water dispensing and provides fresh, cold water. Simply press the panel with the carafe or glass, and enjoy the water. This enables you to save on purchasing bottles of water and to live more sustainably.



PowerCooling

Do you want to be sure that the cold is distributed as evenly as possible in your refrigerator? If so, the PowerCooling system is what you need. The fan – as powerful as it is quiet – distributes the cold air efficiently throughout the entire refrigeration compartment.



Touch & Swipe display

Control of your Liebherr at your fingertips: thanks to the Touch & Swipe display, you can operate your refrigerator intuitively and with ease. Simply select functions such as SuperCool on the colour display by tapping and swiping. The temperature is controlled just as easily. And, what if you are not actively using the display? It then shows you the actual temperature.



SoftSystem

From breakfast to a midnight snack – a fridge needs to be open and closed on many occasions. And your Liebherr makes this a lot of fun. With the SoftSystem, your fridge door closes softly and safely, and in a way which is pleasantly quiet and light. Bottles stored in the inside door remain securely in place – nothing rattles or wobbles.



LED ceiling lighting

The LED ceiling lighting illuminates the interior from above – providing a good overview of your food. Another highlight: the LEDs are positioned in front of the glass shelves so that even a full refrigerator is well lit.



Recessed grip

Special and functional: You can open the appliance very easily using the vertically integrated and ergonomically fitted handle. Additionally, the modern and puristic design fits perfectly into your hands-free kitchen.



VarioTemp

VarioTemp means you have plenty of scope when storing food in your fridge freezer. This is because you can also set the accurate temperature in the freezer compartment in a range between $-2\text{ }^{\circ}\text{C}$ and $+14\text{ }^{\circ}\text{C}$ – and therefore also use this compartment as a further cooling zone. For example, it can be used over the short term for drinks and snacks at parties – or over the long term as a cellar compartment for storing potatoes.

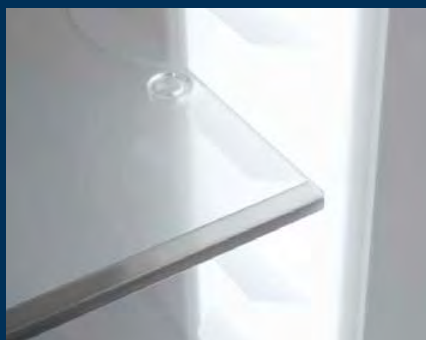

LightTower

Enjoy an optimally illuminated interior: the LightTower shows off the food in its best light and is positioned so that all of your filled fridge is illuminated at all times. The flush mounting of the LightTower in the side walls means there is also more space for your food.



IceMaker with fixed water connection

Are there any ice cubes left? The IceMaker means you never have to ask. With the IceMaker with fixed water connection, the water comes directly from the tap. The MaxIce function allows you to produce up to 1.5 kg of ice cubes a day. The versatile ice compartment divider lets you choose the amount of ice cubes you want to store; easy and just as you like it.

XL-NoFrost fridge-freezers



IceMaker with fixed water connection

Are there any ice cubes left? The IceMaker means you never have to ask. With the IceMaker with fixed water connection, the water comes directly from the tap. The MaxIce function allows you to produce up to 1.5 kg of ice cubes a day. The versatile ice compartment divider lets you choose the amount of ice cubes you want to store; easy and just as you like it.



EasyFresh

The guarantee of market freshness in the home is our EasyFresh Safe. Whether it's unpackaged vegetables or fruit, this ensures optimal storage for everything. Thanks to the air-tight closure, the food causes the humidity in the safe to rise. This keeps the food fresh for a long time.



← 75 →



CNsdd 776i

Prime

Energy efficiency class:	D ^A / ₁ ^G
Energy consumption year / 24 hrs:	232 / 0.635 kWh¹
Total volume ² :	487 l
Volume:	Fridge: 349.1 l / Freezer compartment: 139 l
Noise output / noise class:	34 dB(A) / B, SuperSilent
Climate rating:	SN-T (from +10 °C to +43 °C)
Door / side walls:	SmartSteel / silver
Exterior dimensions in cm (h / w / d):	201.5 / 74.7 / 67.5¹

Easy Fresh	Duo Cooling	No Frost	Super Cool	Super Frost	Vario Temp	Glass & Steel Interior	Light Tower	Ice Maker
Soft System	Super Silent	Touch & Swipe Display	Vario Space	Smart Device				

Controls

- 2.4" TFT-colour display behind-the-door, touch- & swipe
- Digital temperature display for fridge and freezer compartments
- SmartDeviceBox included
- Alarm in case of malfunction: visual and acoustic
- Door alarm: visual and acoustic

Fridge compartment

- PowerCooling with FreshAir activated charcoal filter
- Premium GlassLine storage shelves with bottle holder, removable VarioBoxes, adjustable egg tray, butter dish
- 5 GlassLine storage shelves, of which 1 is divided into two parts
- VarioSafe
- Bottle shelf
- LED light panel, both sides
- 1 EasyFresh Safe on telescopic rails

Freezer compartment *******

- 3 drawers, VarioSpace
- IceMaker with fixed 3/4" water connection
- Ice cube production in 24 hrs: 1.2 kg
- Ice cube reservoir 5.4 kg
- LED lighting
- Temperature rise time: 20 h
- Freezing capacity in 24 hrs: 10 kg
- Safety glass fittings

Key features

- Slimline handles with integrated opening mechanism
- Transport handles, front and at back, transport castors at back
- Height-adjustable feet at front
- Reversible door hinging, right
- Replaceable door seal
- Dry rear wall in stainless steel with SmartSteel

¹ To achieve the indicated energy consumption level, the wall spacers provided with the appliance must be used. These increase the appliance depth by approximately 1.5 cm. If the wall spacers are not used, the appliance will remain fully functional, but will have a slightly higher energy consumption level.



PowerCooling

Do you want to be sure that the cold is distributed as evenly as possible in your refrigerator? If so, the PowerCooling system is what you need. The fan – as powerful as it is quiet – distributes the cold air efficiently throughout the entire refrigeration compartment.



EasyTwist-Ice

Whether it's a summer day or a party: Thanks to EasyTwist-Ice, you can prepare a supply of ice cubes quickly and easily – without the need for a fixed water connection. Simply fill the tank with water, let it freeze and then release the finished ice cubes with a simple twist – and you're ready to serve cool drinks. The EasyTwist-Ice is easy to clean and ensures hygienic ice cube production at all times.

XL-NoFrost fridge-freezers



← 75 →



CNsfa 7723

Plus

Energy efficiency class:	A ¹
Energy consumption year / 24 hrs:	118 / 0.323 kWh¹
Total volume ² :	485 l
Volume:	Fridge: 347.7 l / Freezer compartment: 138 l
Noise output / noise class:	35 dB(A) / B, SuperSilent
Climate rating:	SN-T (from +10 °C to +43 °C)
Door / side walls:	SteelFinish / silver
Exterior dimensions in cm (h / w / d):	201.5 / 74.7 / 67.5¹

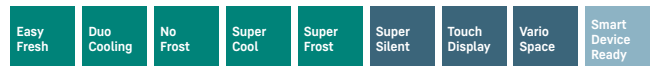

Controls

- LC monochrome display behind-the-door, touch electronic
- Digital temperature display for fridge and freezer compartments
- SmartDeviceBox: optional accessory
- Alarm in case of malfunction: visual and acoustic
- Door alarm: visual and acoustic

Fridge compartment

- PowerCooling with FreshAir activated charcoal filter
- Premium GlassLine storage shelves with bottle holder, egg tray, FlexCube
- 5 GlassLine storage shelves, of which 1 is divided into two parts
- VarioSafe
- Bottle shelf
- LED ceiling lighting
- 1 EasyFresh Safe on running rails

Freezer compartment ********

- 3 drawers, VarioSpace
- Ice cube tray
- Temperature rise time: 20 h
- Freezing capacity in 24 hrs: 10 kg
- Safety glass fittings

Key features

- Vertical recessed handles
- Transport handles, front and at back, transport castors at back
- Height-adjustable feet at front
- Reversible door hinging, right
- Replaceable door seal

² In accordance with Regulation EU 2019/2016 we indicate the total volume to the nearest integer (rounded off) and the volume of the frozen compartments and refrigeration compartments to one place after the decimal point. You can find the full range of efficiency classes at page 15. According to (EU) 2017/1369 6a.

BioFresh NoFrost fridge-freezers



BioFresh with HydroBreeze

Do you want to cool fruit and vegetables like professionals? You'll be inspired by HydroBreeze. The cold mist combined with a temperature in the safe of around 0 °C gives food that extra boost for longer shelf life. And it creates a genuine visual wow effect. HydroBreeze is activated every 90 min. for 4 seconds and for 8 seconds when the door is opened.



IceMaker with fixed water connection

Are there any ice cubes left? The IceMaker means you never have to ask. With the IceMaker with fixed water connection, the water comes directly from the tap. The MaxIce function allows you to produce up to 1.5 kg of ice cubes a day. The versatile ice compartment divider lets you choose the amount of ice cubes you want to store; easy and just as you like it.



← 60 →



CBNstb 579i

Peak

Energy efficiency class:	B ^A _G ¹
Energy consumption year / 24 hrs:	144 / 0.394 kWh¹
Total volume ² :	362 l
Volume:	Fridge: 160.3 l / BioFresh compartment: 98.7 l / Freezer compartment: 104 l
Noise output / noise class:	33 dB(A) / B, SuperSilent
Climate rating:	SN-T (from +10 °C to +43 °C)
Door / side walls:	SmartSteel / SmartSteel
Exterior dimensions in cm (h / w / d):	201.5 / 59.7 / 67.5¹

Bio Fresh Professional	Hydro Breeze	Duo Cooling	No Frost	Super Cool	Super Frost	Vario Temp	Glass & Steel Interior	Light Tower
Infinity Spring	Ice Maker	Soft System	Soft-Telescopic Rails	Super Silent	Touch & Swipe Display	Vario Space	Smart Device	

Controls

- 2.4" TFT-colour display in-the-door, touch- & swipe
- Digital temperature display for fridge, BioFresh and freezer compartments
- SmartDeviceBox included
- Alarm in case of malfunction: visual and acoustic
- Door alarm: visual and acoustic

Fridge and BioFresh compartments

- PowerCooling with Ambilight and FreshAir activated charcoal filter
- Premium GlassLine storage shelves with bottle holder, removable VarioBoxes, adjustable egg tray, butter dish
- 2 GlassLine storage shelves, of which 1 is divided into two parts
- VarioSafe
- Integrated bottle shelf
- LED light panel, both sides
- LED BioFresh lighting
- 2 BioFresh Safes with SoftTelescopic, 1 Fruit & Vegetable Safe with HydroBreeze, 1 Meat & Dairy Safe, 1 FlexSystem
- InfinitySpring with fixed 3/4" water connection

Freezer compartment *******

- 3 drawers, of which 2 with telescopic partial pull-out, VarioSpace
- IceMaker with fixed 3/4" water connection, LED lighting
- Ice cube production in 24 hrs: 1.2 kg
- Ice cube reservoir 5.4 kg
- LED lighting
- Temperature rise time: 20 h
- Freezing capacity in 24 hrs: 10 kg
- Safety glass fittings

Key features

- Vertical recessed handles
- Transport handles, front and at back, transport castors at back
- Height-adjustable feet at front
- Reversible door hinging, right
- Replaceable door seal
- Dry rear wall and door panel in stainless steel with SmartSteel

¹ To achieve the indicated energy consumption level, the wall spacers provided with the appliance must be used. These increase the appliance depth by approximately 1.5 cm. If the wall spacers are not used, the appliance will remain fully functional, but will have a slightly higher energy consumption level.



Our energy saving fridge-freezers in class A

That feeling of getting fresh fruit and crisp vegetables out of the fridge just got better. With our class A fridge-freezers, you have the best energy efficiency available and sophisticated freshness technology to keep your food fresher for longer - saving resources twice over.



VarioTemp

VarioTemp means you have plenty of scope when storing food in your fridge freezer. This is because you can also set the accurate temperature in the freezer compartment in a range between -2 °C and +14 °C – and therefore also use this compartment as a further cooling zone. For example, it can be used over the short term for drinks and snacks at parties – or over the long term as a cellar compartment for storing potatoes.

BioFresh NoFrost fridge-freezers



← 60 →



CBNsda 575i

Prime

Energy efficiency class:	A ¹
Energy consumption year / 24 hrs:	116 / 0.317 kWh¹
Total volume ² :	362 l
Volume: Fridge: 159.9 l / BioFresh compartment: 99.2 l / Freezer compartment: 103 l	
Noise output / noise class:	33 dB(A) / B, SuperSilent
Climate rating:	SN-T (from +10 °C to +43 °C)
Door / side walls:	SmartSteel / silver
Exterior dimensions in cm (h / w / d):	201.5 / 59.7 / 67.5¹

Bio Fresh	Duo Cooling	No Frost	Super Cool	Super Frost	Vario Temp	Glass & Steel Interior	Light Tower	Easy Twist Ice
Soft System	Soft-Telescopic Rails	Super Silent	Touch & Swipe Display	Vario Space	Smart Device			

Controls

- 2.4" TFT-colour display behind-the-door, touch- & swipe
- Digital temperature display for fridge, BioFresh and freezer compartments
- SmartDeviceBox included
- Alarm in case of malfunction: visual and acoustic
- Door alarm: visual and acoustic

Freezer compartment *******

- 3 drawers, VarioSpace
- EasyTwist-Ice
- LED lighting
- Temperature rise time: 20 h
- Freezing capacity in 24 hrs: 10 kg
- Safety glass fittings

Key features

- Slimline handles with integrated opening mechanism
- Transport handles, front and at back, transport castors at back
- Height-adjustable feet at front
- Reversible door hinging, right
- Replaceable door seal
- Dry rear wall in stainless steel with SmartSteel

Fridge and BioFresh compartments

- PowerCooling with FreshAir activated charcoal filter
- Premium GlassLine storage shelves with bottle holder, removable VarioBoxes, adjustable egg tray, butter dish
- 2 GlassLine storage shelves, of which 1 is divided into two parts
- VarioSafe
- Integrated bottle shelf
- LED light panel, both sides
- LED BioFresh lighting
- 2 BioFresh Safes with SoftTelescopic, 1 Fruit & Vegetable Safe, 1 Meat & Dairy Safe

² In accordance with Regulation EU 2019/2016 we indicate the total volume to the nearest integer (rounded off) and the volume of the frozen compartments and refrigeration compartments to one place after the decimal point.

You can find the full range of efficiency classes at page 15. According to (EU) 2017/1369 ga.

BioFresh NoFrost fridge-freezers



← 60 →

CBN**b**da 572i

Plus



Energy efficiency class:	A ¹ / _G
Energy consumption year / 24 hrs:	116 / 0.317 kWh ¹
Total volume ² :	360 l
Volume: Fridge: 158.8 l / BioFresh compartment: 98.9 l / Freezer compartment: 103 l	
Noise output / noise class:	34 dB(A) / B, SuperSilent
Climate rating:	SN-T (from +10 °C to +43 °C)
Door / side walls:	BlackSteel / black
Exterior dimensions in cm (h / w / d):	201.5 / 59.7 / 67.5 ¹

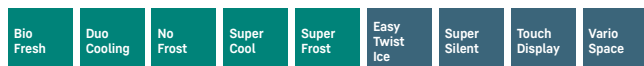

Smart Device

Controls

- LC monochrome display behind-the-door, touch electronic
- Digital temperature display for fridge and freezer compartments
- SmartDeviceBox included
- Alarm in case of malfunction: visual and acoustic
- Door alarm: visual and acoustic

Fridge and BioFresh compartments

- PowerCooling with FreshAir activated charcoal filter
- Plastic door shelves with bottle holder, egg tray, FlexCube
- 3 GlassLine storage shelves, of which 1 is divided into two parts
- Integrated bottle shelf
- LED ceiling lighting
- 2 BioFresh Safes with telescopic partial pull-out, 1 Fruit & Vegetable Safe, 1 Meat & Dairy Safe

Freezer compartment **E4** ¹/_{***}

- 3 drawers, VarioSpace
- EasyTwist-Ice
- Temperature rise time: 20 h
- Freezing capacity in 24 hrs: 10 kg
- Safety glass fittings

Key features

- Vertical recessed handles
- Transport handles, front and at back, transport castors at back
- Height-adjustable feet at front
- Reversible door hinging, right
- Replaceable door seal



← 60 →

CBN**s**da 572i

Plus



Energy efficiency class:	A ¹ / _G
Energy consumption year / 24 hrs:	116 / 0.317 kWh ¹
Total volume ² :	360 l
Volume: Fridge: 158.8 l / BioFresh compartment: 98.9 l / Freezer compartment: 103 l	
Noise output / noise class:	34 dB(A) / B, SuperSilent
Climate rating:	SN-T (from +10 °C to +43 °C)
Door / side walls:	SmartSteel / silver
Exterior dimensions in cm (h / w / d):	201.5 / 59.7 / 67.5 ¹



Smart Device

Controls

- LC monochrome display behind-the-door, touch electronic
- Digital temperature display for fridge and freezer compartments
- SmartDeviceBox included
- Alarm in case of malfunction: visual and acoustic
- Door alarm: visual and acoustic

Fridge and BioFresh compartments

- PowerCooling with FreshAir activated charcoal filter
- Plastic door shelves with bottle holder, egg tray, FlexCube
- 3 GlassLine storage shelves, of which 1 is divided into two parts
- Integrated bottle shelf
- LED ceiling lighting
- 2 BioFresh Safes with telescopic partial pull-out, 1 Fruit & Vegetable Safe, 1 Meat & Dairy Safe

Freezer compartment **E4** ¹/_{***}

- 3 drawers, VarioSpace
- EasyTwist-Ice
- Temperature rise time: 20 h
- Freezing capacity in 24 hrs: 10 kg
- Safety glass fittings

Key features

- Vertical recessed handles
- Transport handles, front and at back, transport castors at back
- Height-adjustable feet at front
- Reversible door hinging, right
- Replaceable door seal



PowerCooling

Do you want to be sure that the cold is distributed as evenly as possible in your refrigerator? If so, the PowerCooling system is what you need. The fan – as powerful as it is quiet – distributes the cold air efficiently throughout the entire refrigeration compartment.



LED ceiling lighting

The LED ceiling lighting illuminates the interior from above – providing a good overview of your food. Another highlight: the LEDs are positioned in front of the glass shelves so that even a full refrigerator is well lit.

BioFresh NoFrost fridge-freezers



← 60 →



CBNa 572i

Plus

Energy efficiency class:	A ¹
Energy consumption year / 24 hrs:	116 / 0.317 kWh¹
Total volume ² :	360 l
Volume: Fridge: 158.8 l / BioFresh compartment: 98.9 l / Freezer compartment: 103 l	
Noise output / noise class:	34 dB(A) / B, SuperSilent
Climate rating:	SN-T (from +10 °C to +43 °C)
Door / side walls:	white / white
Exterior dimensions in cm (h / w / d):	201.5 / 59.7 / 67.5¹

Bio Fresh	Duo Cooling	No Frost	Super Cool	Super Frost	Easy Twist Ice	Super Silent	Touch Display	Vario Space
-----------	-------------	----------	------------	-------------	----------------	--------------	---------------	-------------

Smart Device

Controls

- LC monochrome display behind-the-door, touch electronic
- Digital temperature display for fridge and freezer compartments
- SmartDeviceBox included
- Alarm in case of malfunction: visual and acoustic
- Door alarm: visual and acoustic

Fridge and BioFresh compartments

- PowerCooling with FreshAir activated charcoal filter
- Plastic door shelves with bottle holder, egg tray, FlexCube
- 3 GlassLine storage shelves, of which 1 is divided into two parts
- Integrated bottle shelf
- LED ceiling lighting
- 2 BioFresh Safes with telescopic partial pull-out, 1 Fruit & Vegetable Safe, 1 Meat & Dairy Safe

Freezer compartment ********

- 3 drawers, VarioSpace
- EasyTwist-Ice
- Temperature rise time: 20 h
- Freezing capacity in 24 hrs: 10 kg
- Safety glass fittings

Key features

- Vertical recessed handles
- Transport handles, front and at back, transport castors at back
- Height-adjustable feet at front
- Reversible door hinging, right
- Replaceable door seal

² In accordance with Regulation EU 2019/2016 we indicate the total volume to the nearest integer (rounded off) and the volume of the frozen compartments and refrigeration compartments to one place after the decimal point. You can find the full range of efficiency classes at page 15. According to [EU] 2017/1369 6a.

BioFresh NoFrost fridge-freezers

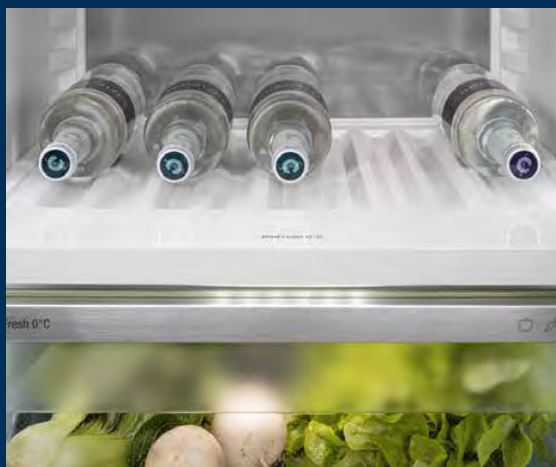

Bottle shelf above the BioFresh Safe

Expecting guests and want to chill a few more drinks than usual? The bottle shelf above the BioFresh Safes exists for this very reason. Simply remove the glass shelf above the bottle shelf in one easy step – and you can now safely store and cool bottles of various sizes.



DuoCooling

DuoCooling uses two completely separate refrigeration circuits to ensure no air is exchanged between the fridge and freezer compartments. The food stays fresh without drying out, and odours are not transferred. This means throwing less away, shopping less often, but saving more and greater enjoyment.



← 60 →



CBNbdc 573i

Plus

Energy efficiency class:	C ¹
Energy consumption year / 24 hrs:	181 / 0.495 kWh ¹
Total volume ² :	360 l
Volume: Fridge: 158.8 l / BioFresh compartment: 98.9 l / Freezer compartment: 103 l	
Noise output / noise class:	35 dB(A) / B, SuperSilent
Climate rating:	SN-T (from +10 °C to +43 °C)
Door / side walls:	BlackSteel / black
Exterior dimensions in cm (h / w / d):	201.5 / 59.7 / 67.5 ¹

Bio Fresh	Duo Cooling	No Frost	Super Cool	Super Frost	Super Silent	Touch & Swipe Display	Vario Space	Smart Device
-----------	-------------	----------	------------	-------------	--------------	-----------------------	-------------	--------------

Controls

- 2.4" TFT-colour display in-the-door, touch- & swipe
- Digital temperature display for fridge, BioFresh and freezer compartments
- SmartDeviceBox included
- Alarm in case of malfunction: visual and acoustic
- Door alarm: visual and acoustic

Fridge and BioFresh compartments

- PowerCooling with FreshAir activated charcoal filter
- Plastic door shelves with bottle holder, egg tray, FlexCube
- 3 GlassLine storage shelves, of which 1 is divided into two parts
- Integrated bottle shelf
- LED ceiling lighting
- 2 BioFresh Safes with telescopic partial pull-out, 1 Fruit & Vegetable Safe, 1 Meat & Dairy Safe

Freezer compartment **4** ¹ *******

- 3 drawers, VarioSpace
- Ice cube tray
- Temperature rise time: 20 h
- Freezing capacity in 24 hrs: 10 kg
- Safety glass fittings

Key features

- Vertical recessed handles
- Transport handles, front and at back, transport castors at back
- Height-adjustable feet at front
- Reversible door hinging, right
- Replaceable door seal

¹ To achieve the indicated energy consumption level, the wall spacers provided with the appliance must be used. These increase the appliance depth by approximately 1.5 cm. If the wall spacers are not used, the appliance will remain fully functional, but will have a slightly higher energy consumption level.



← 60 →

CBNsfc 57vi
Plus

Energy efficiency class:	
Energy consumption year / 24 hrs:	181 / 0.495 kWh¹
Total volume ² :	360 l
Volume: Fridge: 158.8 l / BioFresh compartment: 98.9 l / Freezer compartment: 103 l	
Noise output / noise class:	35 dB(A) / B, SuperSilent
Climate rating:	SN-T (from +10°C to +43°C)
Door / side walls:	SteelFinish / silver
Exterior dimensions in cm (h / w / d):	201.5 / 59.7 / 67.5¹



Controls

- LC monochrome display behind-the-door, touch electronic
- Digital temperature display for fridge and freezer compartments
- SmartDeviceBox included
- Alarm in case of malfunction: visual and acoustic
- Door alarm: visual and acoustic

Fridge and BioFresh compartments

- PowerCooling with FreshAir activated charcoal filter
- Plastic door shelves with bottle holder, egg tray, FlexCube
- 3 GlassLine storage shelves, of which 1 is divided into two parts
- Integrated bottle shelf
- LED ceiling lighting
- 2 BioFresh Safes with telescopic partial pull-out, 2 Fruit & Vegetable Safes, 2 FlexSystem

Freezer compartment

- 3 drawers, VarioSpace
- EasyTwist-Ice
- Temperature rise time: 20 h
- Freezing capacity in 24 hrs: 10 kg
- Safety glass fittings

Key features

- Vertical recessed handles
- Transport handles, front and at back, transport castors at back
- Height-adjustable feet at front
- Reversible door hinging, right
- Replaceable door seal

² In accordance with Regulation EU 2019/2016 we indicate the total volume to the nearest integer (rounded off) and the volume of the frozen compartments and refrigeration compartments to one place after the decimal point. You can find the full range of efficiency classes at page 15. According to (EU) 2017/1369 6a.



← 60 →

CBnc 5723
Plus

Energy efficiency class:	
Energy consumption year / 24 hrs:	181 / 0.495 kWh¹
Total volume ² :	360 l
Volume: Fridge: 158.8 l / BioFresh compartment: 98.9 l / Freezer compartment: 103 l	
Noise output / noise class:	35 dB(A) / B, SuperSilent
Climate rating:	SN-T (from +10°C to +43°C)
Door / side walls:	white / white
Exterior dimensions in cm (h / w / d):	201.5 / 59.7 / 67.5¹



Controls

- LC monochrome display behind-the-door, touch electronic
- Digital temperature display for fridge and freezer compartments
- SmartDeviceBox: optional accessory
- Alarm in case of malfunction: visual and acoustic
- Door alarm: visual and acoustic

Fridge and BioFresh compartments

- PowerCooling with FreshAir activated charcoal filter
- Plastic door shelves with bottle holder, egg tray, FlexCube
- 3 GlassLine storage shelves, of which 1 is divided into two parts
- Integrated bottle shelf
- LED ceiling lighting
- 2 BioFresh Safes with telescopic partial pull-out, 1 Fruit & Vegetable Safe, 1 Meat & Dairy Safe

Freezer compartment

- 3 drawers, VarioSpace
- EasyTwist-Ice
- Temperature rise time: 20 h
- Freezing capacity in 24 hrs: 10 kg
- Safety glass fittings

Key features

- Vertical recessed handles
- Transport handles, front and at back, transport castors at back
- Height-adjustable feet at front
- Reversible door hinging, right
- Replaceable door seal

BioFresh NoFrost fridge-freezers

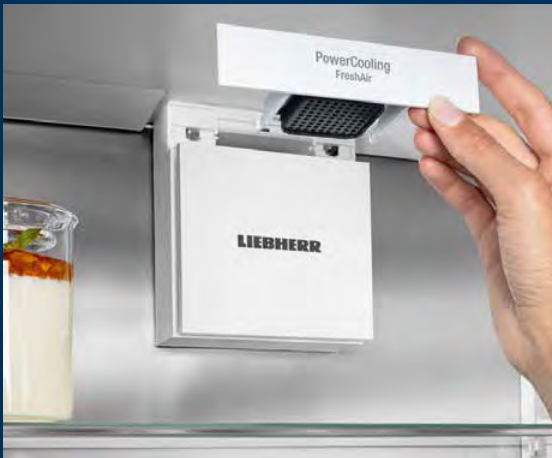

PowerCooling

Do you want to be sure that the cold is distributed as evenly as possible in your refrigerator? If so, the PowerCooling system is what you need. The fan – as powerful as it is quiet – distributes the cold air efficiently throughout the entire refrigeration compartment.



EasyTwist-Ice

Whether it's a summer day or a party: Thanks to EasyTwist-Ice, you can prepare a supply of ice cubes quickly and easily – without the need for a fixed water connection. Simply fill the tank with water, let it freeze and then release the finished ice cubes with a simple twist – and you're ready to serve cool drinks. The EasyTwist-Ice is easy to clean and ensures hygienic ice cube production at all times.



← 60 →



CBNbda 5223

Plus

Energy efficiency class:	A ¹ A B C
Energy consumption year / 24 hrs:	109 / 0.298 kWh ¹
Total volume ² :	320 l
Volume:	Fridge: 164.7 l / BioFresh compartment: 52.9 l / Freezer compartment: 103 l
Noise output / noise class:	34 dB(A) / B, SuperSilent
Climate rating:	SN-T (from +10 °C to +43 °C)
Door / side walls:	BlackSteel / black
Exterior dimensions in cm (h / w / d):	185.5 / 59.7 / 67.5 ¹

Bio Fresh	Duo Cooling	No Frost	Super Cool	Super Frost	Easy Twist Ice	Super Silent	Touch Display	Vario Space
-----------	-------------	----------	------------	-------------	----------------	--------------	---------------	-------------

Smart Device Ready

Controls

- LC monochrome display behind-the-door, touch electronic
- Digital temperature display for fridge and freezer compartments
- SmartDeviceBox: optional accessory
- Alarm in case of malfunction: visual and acoustic
- Door alarm: visual and acoustic

Key features

- Vertical recessed handles
- Transport handles, front and at back, transport castors at back
- Height-adjustable feet at front
- Reversible door hinging, right
- Replaceable door seal

Colour / material options:

CBNsda 5223 with Stainless steel front

Fridge and BioFresh compartments

- PowerCooling with FreshAir activated charcoal filter
- Plastic door shelves with bottle holder, egg tray, FlexCube
- 4 GlassLine storage shelves, of which 1 is divided into two parts
- Integrated bottle shelf
- LED ceiling lighting
- 1 BioFresh Safe with telescopic partial pull-out, 1 Fruit & Vegetable Safe

Freezer compartment *******

- 3 drawers, VarioSpace
- EasyTwist-Ice
- Temperature rise time: 20 h
- Freezing capacity in 24 hrs: 10 kg
- Safety glass fittings

¹ To achieve the indicated energy consumption level, the wall spacers provided with the appliance must be used. These increase the appliance depth by approximately 1.5 cm. If the wall spacers are not used, the appliance will remain fully functional, but will have a slightly higher energy consumption level.



← 60 →



← 60 →



CBNsfc 5223 Plus

Energy efficiency class:	C ^A / _G ¹
Energy consumption year / 24 hrs:	170 / 0.465 kWh¹
Total volume ² :	320 l
Volume: Fridge: 164.7 l / BioFresh compartment: 52.9 l / Freezer compartment: 103 l	
Noise output / noise class:	35 dB(A) / B, SuperSilent
Climate rating:	SN-T (from +10 °C to +43 °C)
Door / side walls:	SteelFinish / silver
Exterior dimensions in cm (h / w / d):	185.5 / 59.7 / 67.5¹



Controls

- LC monochrome display behind-the-door, touch electronic
- Digital temperature display for fridge and freezer compartments
- SmartDeviceBox: optional accessory
- Alarm in case of malfunction: visual and acoustic
- Door alarm: visual and acoustic

Key features

- Vertical recessed handles
- Transport handles, front and at back, transport castors at back
- Height-adjustable feet at front
- Reversible door hinging, right
- Replaceable door seal

Fridge and BioFresh compartments

- PowerCooling with FreshAir activated charcoal filter
- Plastic door shelves with bottle holder, egg tray, FlexCube
- 4 GlassLine storage shelves, of which 1 is divided into two parts
- Integrated bottle shelf
- LED ceiling lighting
- 1 BioFresh Safe with telescopic partial pull-out, 1 Fruit & Vegetable Safe

Freezer compartment ********

- 3 drawers, VarioSpace
- EasyTwist-Ice
- Temperature rise time: 20 h
- Freezing capacity in 24 hrs: 10 kg
- Safety glass fittings



CBNc 5223 Plus

Energy efficiency class:	C ^A / _G ¹
Energy consumption year / 24 hrs:	170 / 0.465 kWh¹
Total volume ² :	320 l
Volume: Fridge: 164.7 l / BioFresh compartment: 52.9 l / Freezer compartment: 103 l	
Noise output / noise class:	35 dB(A) / B, SuperSilent
Climate rating:	SN-T (from +10 °C to +43 °C)
Door / side walls:	white / white
Exterior dimensions in cm (h / w / d):	185.5 / 59.7 / 67.5¹



Controls

- LC monochrome display behind-the-door, touch electronic
- Digital temperature display for fridge and freezer compartments
- SmartDeviceBox: optional accessory
- Alarm in case of malfunction: visual and acoustic
- Door alarm: visual and acoustic

Key features

- Vertical recessed handles
- Transport handles, front and at back, transport castors at back
- Height-adjustable feet at front
- Reversible door hinging, right
- Replaceable door seal

Fridge and BioFresh compartments

- PowerCooling with FreshAir activated charcoal filter
- Plastic door shelves with bottle holder, egg tray, FlexCube
- 4 GlassLine storage shelves, of which 1 is divided into two parts
- Integrated bottle shelf
- LED ceiling lighting
- 1 BioFresh Safe with telescopic partial pull-out, 1 Fruit & Vegetable Safe

Freezer compartment ********

- 3 drawers, VarioSpace
- EasyTwist-Ice
- Temperature rise time: 20 h
- Freezing capacity in 24 hrs: 10 kg
- Safety glass fittings

² In accordance with Regulation EU 2019/2016 we indicate the total volume to the nearest integer (rounded off) and the volume of the frozen compartments and refrigeration compartments to one place after the decimal point. You can find the full range of efficiency classes at page 15. According to (EU) 2017/1369 6a.

NoFrost fridge-freezers



← 60 →

CnC 5724

Plus



Energy efficiency class:	C ¹ _{A G}
Energy consumption year / 24 hrs:	168 / 0.460 kWh ¹
Total volume ² :	359 l
Volume:	Fridge: 227.1 l / Freezer compartment: 132 l
Noise output / noise class:	35 dB(A) / B, SuperSilent
Climate rating:	SN-T (from +10 °C to +43 °C)
Door / side walls:	white / white
Exterior dimensions in cm (h / w / d):	201.5 / 59.7 / 67.5 ¹

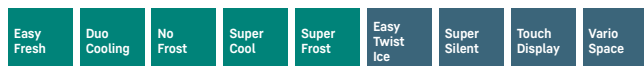

Smart Device Ready

Controls

- LC monochrome display behind-the-door, touch electronic
- Digital temperature display for fridge and freezer compartments
- SmartDeviceBox: optional accessory
- Alarm in case of malfunction: visual and acoustic
- Door alarm: visual and acoustic

Key features

- Vertical recessed handles
- Transport handles, front and at back, transport castors at back
- Height-adjustable feet at front
- Reversible door hinging, right
- Replaceable door seal

Fridge compartment

- PowerCooling with FreshAir activated charcoal filter
- Plastic door shelves with bottle holder, egg tray, FlexCube
- 4 GlassLine storage shelves, of which 1 is divided into two parts
- VarioSafe
- Bottle shelf
- LED ceiling lighting
- 1 EasyFresh Safe on running rails

Freezer compartment **E4 *****

- 4 drawers, VarioSpace
- EasyTwist-Ice
- Temperature rise time: 20 h
- Freezing capacity in 24 hrs: 10 kg
- Safety glass fittings



← 60 →

CNsda 5723

Plus



Energy efficiency class:	A ¹ _{A G}
Energy consumption year / 24 hrs:	104 / 0.284 kWh ¹
Total volume ² :	371 l
Volume:	Fridge: 267.9 l / Freezer compartment: 103 l
Noise output / noise class:	34 dB(A) / B, SuperSilent
Climate rating:	SN-T (from +10 °C to +43 °C)
Door / side walls:	SmartSteel / silver
Exterior dimensions in cm (h / w / d):	201.5 / 59.7 / 67.5 ¹



Smart Device Ready

Controls

- LC monochrome display behind-the-door, touch electronic
- Digital temperature display for fridge and freezer compartments
- SmartDeviceBox: optional accessory
- Alarm in case of malfunction: visual and acoustic
- Door alarm: visual and acoustic

Key features

- Vertical recessed handles
- Transport handles, front and at back, transport castors at back
- Height-adjustable feet at front
- Reversible door hinging, right
- Replaceable door seal

Colour / material options:

CNbda 5723 in BlackSteel

Fridge compartment

- PowerCooling with FreshAir activated charcoal filter
- Plastic door shelves with bottle holder, egg tray, FlexCube
- 5 GlassLine storage shelves, of which 1 is divided into two parts
- VarioSafe
- Bottle shelf
- LED ceiling lighting
- 1 EasyFresh Safe on running rails

Freezer compartment **E4 *****

- 3 drawers, VarioSpace
- EasyTwist-Ice
- Temperature rise time: 20 h
- Freezing capacity in 24 hrs: 10 kg
- Safety glass fittings

¹ To achieve the indicated energy consumption level, the wall spacers provided with the appliance must be used. These increase the appliance depth by approximately 1.5 cm. If the wall spacers are not used, the appliance will remain fully functional, but will have a slightly higher energy consumption level.



← 60 →

CNSfd 5704

Pure



Energy efficiency class:	
Energy consumption year / 24 hrs:	210 / 0.575 kWh ¹
Total volume ² :	359 l
Volume:	Fridge: 227.1 l / Freezer compartment: 132 l
Noise output / noise class:	35 dB(A) / B, SuperSilent
Climate rating:	SN-T (from +10 °C to +43 °C)
Door / side walls:	SteelFinish / silver
Exterior dimensions in cm (h / w / d):	201.5 / 59.7 / 67.5 ¹



Controls

- LC monochrome display behind-the-door, touch electronic
- Digital temperature display for fridge and freezer compartments
- SmartDeviceBox: optional accessory
- Alarm in case of malfunction: visual and acoustic
- Door alarm: visual and acoustic

Fridge compartment

- PowerCooling with FreshAir activated charcoal filter
- Plastic door shelves with bottle holder, egg tray
- 4 GlassLine storage shelves
- LED ceiling lighting
- 1 EasyFresh Safe on running rails

Freezer compartment

- 4 drawers, VarioSpace
- Temperature rise time: 20 h
- Freezing capacity in 24 hrs: 10 kg
- Safety glass fittings

Key features

- Vertical recessed handles
- Transport handles, front and at back, transport castors at back
- Height-adjustable feet at front
- Reversible door hinging, right
- Replaceable door seal



← 60 →

CNSfd 5703

Pure



Energy efficiency class:	
Energy consumption year / 24 hrs:	203 / 0.556 kWh ¹
Total volume ² :	371 l
Volume:	Fridge: 267.9 l / Freezer compartment: 103 l
Noise output / noise class:	35 dB(A) / B, SuperSilent
Climate rating:	SN-T (from +10 °C to +43 °C)
Door / side walls:	SteelFinish / silver
Exterior dimensions in cm (h / w / d):	201.5 / 59.7 / 67.5 ¹



Controls

- LC monochrome display behind-the-door, touch electronic
- Digital temperature display for fridge and freezer compartments
- SmartDeviceBox: optional accessory
- Alarm in case of malfunction: visual and acoustic
- Door alarm: visual and acoustic

Fridge compartment

- PowerCooling with FreshAir activated charcoal filter
- Plastic door shelves with bottle holder, egg tray
- 5 GlassLine storage shelves
- LED ceiling lighting
- 1 EasyFresh Safe on running rails

Freezer compartment

- 3 drawers, VarioSpace
- Temperature rise time: 20 h
- Freezing capacity in 24 hrs: 10 kg
- Safety glass fittings

Key features

- Vertical recessed handles
- Transport handles, front and at back, transport castors at back
- Height-adjustable feet at front
- Reversible door hinging, right
- Replaceable door seal

Colour / material options:

CNd 5703 in white

NoFrost fridge-freezers



NoFrost

When you open your freezer, you want to see frozen food – and certainly not ice and frost. NoFrost protects the freezer compartment from unwanted icing, which consumes a lot of energy and can be expensive. NoFrost means no more tedious and time-consuming defrosting of the freezer compartment, more time for other things – and saving money.



DuoCooling

DuoCooling uses two completely separate refrigeration circuits to ensure no air is exchanged between the fridge and freezer compartments. The food stays fresh without drying out, and odours are not transferred. This means throwing less away, shopping less often, but saving more and greater enjoyment.



← 60 →



CNsdb 5223

Plus

Energy efficiency class:	B ¹
Energy consumption year / 24 hrs:	128 / 0.350 kWh ¹
Total volume ² :	330 l
Volume:	Fridge: 227.1 l / Freezer compartment: 103 l
Noise output / noise class:	34 dB(A) / B, SuperSilent
Climate rating:	SN-T (from +10 °C to +43 °C)
Door / side walls:	SmartSteel / silver
Exterior dimensions in cm (h / w / d):	185.5 / 59.7 / 67.5 ¹



Controls

- LC monochrome display behind-the-door, touch electronic
- Digital temperature display for fridge and freezer compartments
- SmartDeviceBox: optional accessory
- Alarm in case of malfunction: visual and acoustic
- Door alarm: visual and acoustic

Fridge compartment

- PowerCooling with FreshAir activated charcoal filter
- Plastic door shelves with bottle holder, egg tray, FlexCube
- 4 GlassLine storage shelves, of which 1 is divided into two parts
- Bottle shelf
- LED ceiling lighting
- 1 EasyFresh Safe on running rails

Freezer compartment **4 x ****

- 3 drawers, VarioSpace
- EasyTwist-Ice
- Temperature rise time: 20 h
- Freezing capacity in 24 hrs: 10 kg
- Safety glass fittings

Key features

- Vertical recessed handles
- Transport handles, front and at back, transport castors at back
- Height-adjustable feet at front
- Reversible door hinging, right
- Replaceable door seal

¹ To achieve the indicated energy consumption level, the wall spacers provided with the appliance must be used. These increase the appliance depth by approximately 1.5 cm. If the wall spacers are not used, the appliance will remain fully functional, but will have a slightly higher energy consumption level.



← 60 →

CNsfd 5204

Pure



Energy efficiency class:	
Energy consumption year / 24 hrs:	202 / 0.553 kWh ¹
Total volume ² :	319 l
Volume:	Fridge: 187.1 l / Freezer compartment: 132 l
Noise output / noise class:	35 dB(A) / B, SuperSilent
Climate rating:	SN-T (from +10 °C to +43 °C)
Door / side walls:	SteelFinish / silver
Exterior dimensions in cm (h / w / d):	185.5 / 59.7 / 67.5 ¹



Controls

- LC monochrome display behind-the-door, touch electronic
- Digital temperature display for fridge and freezer compartments
- SmartDeviceBox: optional accessory
- Alarm in case of malfunction: visual and acoustic
- Door alarm: visual and acoustic

Fridge compartment

- PowerCooling with FreshAir activated charcoal filter
- Plastic door shelves with bottle holder, egg tray
- 3 GlassLine storage shelves
- LED ceiling lighting
- 1 EasyFresh Safe on running rails

Freezer compartment ********

- 4 drawers, VarioSpace
- Temperature rise time: 20 h
- Freezing capacity in 24 hrs: 10 kg
- Safety glass fittings

Key features

- Vertical recessed handles
- Transport handles, front and at back, transport castors at back
- Height-adjustable feet at front
- Reversible door hinging, right
- Replaceable door seal

Colour / material options:

CNd 5204 in white



← 60 →

CNd 5203

Pure



Energy efficiency class:	
Energy consumption year / 24 hrs:	201 / 0.550 kWh ¹
Total volume ² :	330 l
Volume:	Fridge: 227.1 l / Freezer compartment: 103 l
Noise output / noise class:	35 dB(A) / B, SuperSilent
Climate rating:	SN-T (from +10 °C to +43 °C)
Door / side walls:	white / white
Exterior dimensions in cm (h / w / d):	185.5 / 59.7 / 67.5 ¹



Controls

- LC monochrome display behind-the-door, touch electronic
- Digital temperature display for fridge and freezer compartments
- SmartDeviceBox: optional accessory
- Alarm in case of malfunction: visual and acoustic
- Door alarm: visual and acoustic

Fridge compartment

- PowerCooling with FreshAir activated charcoal filter
- Plastic door shelves with bottle holder, egg tray
- 4 GlassLine storage shelves
- LED ceiling lighting
- 1 EasyFresh Safe on running rails

Freezer compartment ********

- 3 drawers, VarioSpace
- Temperature rise time: 20 h
- Freezing capacity in 24 hrs: 10 kg
- Safety glass fittings

Key features

- Vertical recessed handles
- Transport handles, front and at back, transport castors at back
- Height-adjustable feet at front
- Reversible door hinging, right
- Replaceable door seal

Colour / material options:

CNsfd 5203 in SteelFinish

² In accordance with Regulation EU 2019/2016 we indicate the total volume to the nearest integer (rounded off) and the volume of the frozen compartments and refrigeration compartments to one place after the decimal point. You can find the full range of efficiency classes at page 15. According to (EU) 2017/1369 6a.



CUEle 3331



LED light

The space-saving integrated LED light ensures that the whole interior of the refrigerator is evenly and harmoniously lit. With its low energy consumption, the long-lasting LED light is an environmentally friendly solution for a perfect overview of the food in the fridge.



Bottle shelf

The bottle shelf is the practical and elegant answer for storing drinks. As many as five bottles can be chilled and stored neatly.



← 55 →

CUEle 3331

Energy efficiency class:	
Energy consumption year / 24 hrs:	224 / 0.613 kWh ¹
Total volume ² :	296 l
Volume:	Fridge: 212.4 l / Freezer compartment: 84 l
Noise output / noise class:	38 dB(A) / C
Climate rating:	SN-ST (from +10 °C to +38 °C)
Door / side walls:	Stainless steel look / silver
Exterior dimensions in cm (h / w / d):	181.2 / 55 / 63 ¹



Controls

- Mechanical control in interior, control dial
- Individually regulated cooling circuits: 1
- CoolPlus function

Fridge compartment

- Plastic door shelves with bottle holder, egg tray
- 4 GlassLine storage shelves
- Bottle shelf
- LED lighting
- 2 fruit and vegetable drawers

Freezer compartment

- 3 drawers, VarioSpace
- Ice cube tray
- Temperature rise time: 16 h
- Freezing capacity in 24 hrs: 4 kg
- Safety glass fittings

Key features

- SwingLine design
- Recessed handles
- Versatile installation due to front ventilation
- Transport castors at back
- Height-adjustable feet at front
- Reversible door hinging, right

¹ To achieve the indicated energy consumption level, the wall spacers provided with the appliance must be used. These increase the appliance depth by approximately 3.5 cm. If the wall spacers are not used, the appliance will remain fully functional, but will have a slightly higher energy consumption level.

² In accordance with Regulation EU 2019/2016 we indicate the total volume to the nearest integer (rounded off) and the volume of the frozen compartments and refrigeration compartments to one place after the decimal point.

You can find the full range of efficiency classes at page 15. According to (EU) 2017/1369 6a.



CUele 2331



← 55 →

CUE 2831



← 55 →

CUEle 2331

Energy efficiency class:	
Energy consumption year / 24 hrs:	192 / 0.526 kWh¹
Total volume ² :	265 l
Volume:	Fridge: 212.4 l / Freezer compartment: 54 l
Noise output / noise class:	38 dB(A) / C
Climate rating:	SN-ST (from +10 °C to +38 °C)
Door / side walls:	white / white
Exterior dimensions in cm (h / w / d):	161.2 / 55 / 63¹



Controls

- Mechanical control in interior, control dial
- Individually regulated cooling circuits: 1
- CoolPlus function

Fridge compartment

- Plastic door shelves with bottle holder, egg tray
- 4 GlassLine storage shelves
- Bottle shelf
- LED lighting
- 2 fruit and vegetable drawers

Freezer compartment

- 2 drawers, VarioSpace
- Ice cube tray
- Temperature rise time: 14 h
- Freezing capacity in 24 hrs: 3 kg
- Safety glass fittings

Key features

- SwingLine design
- Recessed handles
- Versatile installation due to front ventilation
- Transport castors at back
- Height-adjustable feet at front
- Reversible door hinging, right

Colour / material options:

CUEle 2831 with Stainless steel look

Energy efficiency class:	
Energy consumption year / 24 hrs:	193 / 0.528 kWh¹
Total volume ² :	210 l
Volume:	Fridge: 156.5 l / Freezer compartment: 54 l
Noise output / noise class:	38 dB(A) / C
Climate rating:	SN-ST (from +10 °C to +38 °C)
Door / side walls:	Stainless steel look / silver
Exterior dimensions in cm (h / w / d):	137.2 / 55 / 63¹



Controls

- Mechanical control in interior, control dial
- Individually regulated cooling circuits: 1
- CoolPlus function

Fridge compartment

- Plastic door shelves with bottle holder, egg tray
- 3 GlassLine storage shelves
- LED lighting
- 2 fruit and vegetable drawers

Freezer compartment

- 2 drawers, VarioSpace
- Ice cube tray
- Temperature rise time: 14 h
- Freezing capacity in 24 hrs: 3 kg
- Safety glass fittings

Key features

- SwingLine design
- Recessed handles
- Versatile installation due to front ventilation
- Transport castors at back
- Height-adjustable feet at front
- Reversible door hinging, right

Colour / material options:

CUEle 2331 in white

¹ To achieve the indicated energy consumption level, the wall spacers provided with the appliance must be used. These increase the appliance depth by approximately 3.5 cm. If the wall spacers are not used, the appliance will remain fully functional, but will have a slightly higher energy consumption level.

² In accordance with Regulation EU 2019/2016 we indicate the total volume to the nearest integer (rounded off) and the volume of the frozen compartments and refrigeration compartments to one place after the decimal point.

You can find the full range of efficiency classes at page 15. According to (EU) 2017/1369 6a.

SmartFrost Top Mount fridge-freezers



← 55 →

CTele 2931



← 55 →

CTe 2931



← 55 →

CTele 2531

Energy efficiency class:	
Energy consumption year / 24 hrs:	190 / 0.520 kWh¹
Total volume ² :	270 l
Volume:	Fridge: 218.6 l / Freezer compartment: 52 l
Noise output / noise class:	37 dB(A) / C
Climate rating:	SN-T (from +10 °C to +43 °C)
Door / side walls:	Stainless steel look / silver
Exterior dimensions in cm (h / w / d):	157.1 / 55 / 63¹

Smart Frost

Controls

- Mechanical control in interior, control dial
- Individually regulated cooling circuits: 1

Fridge compartment

- Plastic door shelves with bottle holder, egg tray
- 4 GlassLine storage shelves
- LED lighting
- 1 spacious fruit and vegetable drawer

Freezer compartment

- 4-star freezer compartment
- Ice cube tray
- Temperature rise time: 20 h
- Freezing capacity in 24 hrs: 2.5 kg
- Safety glass fittings

Key features

- SwingLine design
- Recessed handles
- Versatile installation due to front ventilation
- Height-adjustable feet at front
- Reversible door hinging, right

Energy efficiency class:	
Energy consumption year / 24 hrs:	190 / 0.520 kWh¹
Total volume ² :	270 l
Volume:	Fridge: 218.6 l / Freezer compartment: 52 l
Noise output / noise class:	37 dB(A) / C
Climate rating:	SN-T (from +10 °C to +43 °C)
Door / side walls:	white / white
Exterior dimensions in cm (h / w / d):	157.1 / 55 / 63¹

Smart Frost

Controls

- Mechanical control in interior, control dial
- Individually regulated cooling circuits: 1

Fridge compartment

- Plastic door shelves with bottle holder, egg tray
- 4 GlassLine storage shelves
- LED lighting
- 1 spacious fruit and vegetable drawer

Freezer compartment

- 4-star freezer compartment
- Ice cube tray
- Temperature rise time: 20 h
- Freezing capacity in 24 hrs: 2.5 kg
- Safety glass fittings

Key features

- SwingLine design
- Recessed handles
- Versatile installation due to front ventilation
- Height-adjustable feet at front
- Reversible door hinging, right

Energy efficiency class:	
Energy consumption year / 24 hrs:	181 / 0.495 kWh¹
Total volume ² :	233 l
Volume:	Fridge: 189.5 l / Freezer compartment: 44 l
Noise output / noise class:	37 dB(A) / C
Climate rating:	SN-T (from +10 °C to +43 °C)
Door / side walls:	Stainless steel look / silver
Exterior dimensions in cm (h / w / d):	140.1 / 55 / 63¹

Smart Frost

Controls

- Mechanical control in interior, control dial
- Individually regulated cooling circuits: 1

Fridge compartment

- Plastic door shelves with bottle holder, egg tray
- 3 GlassLine storage shelves
- LED lighting
- 1 spacious fruit and vegetable drawer

Freezer compartment

- 4-star freezer compartment
- Ice cube tray
- Temperature rise time: 17 h
- Freezing capacity in 24 hrs: 2.5 kg
- Safety glass fittings

Key features

- SwingLine design
- Recessed handles
- Versatile installation due to front ventilation
- Height-adjustable feet at front
- Reversible door hinging, right

¹ To achieve the indicated energy consumption level, the wall spacers provided with the appliance must be used. These increase the appliance depth by approximately 3.5 cm. If the wall spacers are not used, the appliance will remain fully functional, but will have a slightly higher energy consumption level.



← 55 →

CTe 2531

Energy efficiency class:	
Energy consumption year / 24 hrs:	181 / 0.495 kWh¹
Total volume ² :	233 l
Volume:	Fridge: 189.5 l / Freezer compartment: 44 l
Noise output / noise class:	37 dB(A) / C
Climate rating:	SN-T (from +10 °C to +43 °C)
Door / side walls:	white / white
Exterior dimensions in cm (h / w / d):	140.1 / 55 / 63¹

Smart Frost

Controls

- Mechanical control in interior, control dial
- Individually regulated cooling circuits: 1

Fridge compartment

- Plastic door shelves with bottle holder, egg tray
- 3 GlassLine storage shelves
- LED lighting
- 1 spacious fruit and vegetable drawer

Freezer compartment ********

- 4-star freezer compartment
- Ice cube tray
- Temperature rise time: 17 h
- Freezing capacity in 24 hrs: 2.5 kg
- Safety glass fittings

Key features

- SwingLine design
- Recessed handles
- Versatile installation due to front ventilation
- Height-adjustable feet at front
- Reversible door hinging, right



← 55 →

CTele 2131

Energy efficiency class:	
Energy consumption year / 24 hrs:	181 / 0.495 kWh¹
Total volume ² :	196 l
Volume:	Fridge: 152.2 l / Freezer compartment: 44 l
Noise output / noise class:	37 dB(A) / C
Climate rating:	SN-T (from +10 °C to +43 °C)
Door / side walls:	Stainless steel look / silver
Exterior dimensions in cm (h / w / d):	124.1 / 55 / 63¹

Smart Frost

Controls

- Mechanical control in interior, control dial
- Individually regulated cooling circuits: 1

Fridge compartment

- Plastic door shelves with bottle holder, egg tray
- 3 GlassLine storage shelves
- LED lighting
- 1 spacious fruit and vegetable drawer

Freezer compartment ********

- 4-star freezer compartment
- Ice cube tray
- Temperature rise time: 17 h
- Freezing capacity in 24 hrs: 2.5 kg
- Safety glass fittings

Key features

- SwingLine design
- Recessed handles
- Versatile installation due to front ventilation
- Height-adjustable feet at front
- Reversible door hinging, right



← 55 →

CTe 2131

Energy efficiency class:	
Energy consumption year / 24 hrs:	181 / 0.495 kWh¹
Total volume ² :	196 l
Volume:	Fridge: 152.2 l / Freezer compartment: 44 l
Noise output / noise class:	37 dB(A) / C
Climate rating:	SN-T (from +10 °C to +43 °C)
Door / side walls:	white / white
Exterior dimensions in cm (h / w / d):	124.1 / 55 / 63¹

Smart Frost

Controls

- Mechanical control in interior, control dial
- Individually regulated cooling circuits: 1

Fridge compartment

- Plastic door shelves with bottle holder, egg tray
- 3 GlassLine storage shelves
- LED lighting
- 1 spacious fruit and vegetable drawer

Freezer compartment ********

- 4-star freezer compartment
- Ice cube tray
- Temperature rise time: 17 h
- Freezing capacity in 24 hrs: 2.5 kg
- Safety glass fittings

Key features

- SwingLine design
- Recessed handles
- Versatile installation due to front ventilation
- Height-adjustable feet at front
- Reversible door hinging, right

² In accordance with Regulation EU 2019/2016 we indicate the total volume to the nearest integer (rounded off) and the volume of the frozen compartments and refrigeration compartments to one place after the decimal point. You can find the full range of efficiency classes at page 15. According to (EU) 2017/1369 6a.

Fridges



RBsdc 525i ◊ Prime series



Range overview by appliance height and series

- Prime series
- Plus series
- Pure series

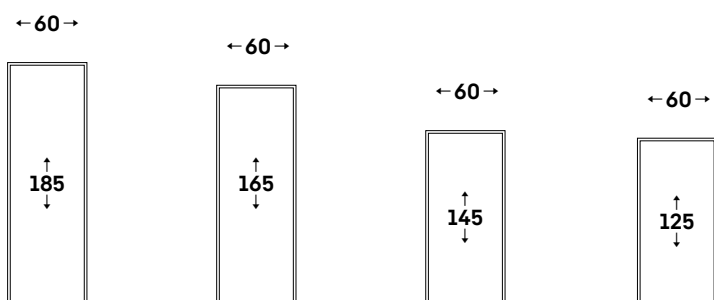

Fridges

BioFresh	RBsdc 525i			
	RBc 5220			
Full-space BioFresh				RBa30 425i
EasyFresh	Rd 5220	Rd 5000	Rd 4600	Rd 4200

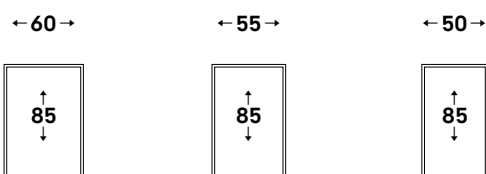

Under counter fridges

EasyFresh	Rsdci 1621		
	Rsdci 1620		
	Rdi 1621		
	Rdi 1620		
		TK 14Vd00	Rd 1201
		Rd 1400	Rd 1200
		Re 1401	Re 1200
		Re 1400	



Rd 4600 ○ Pure series

Fridges



○ Pure series



◇ Plus series



◻ Prime series

	○ Pure series	◇ Plus series	⬡ Prime series
Freshness technology	EasyFresh on integrated drawer guide	EasyFresh on integrated drawer guide	EasyFresh on telescopic rails
	FreshAir filter	FreshAir filter	BioFresh with SoftTelescopic FreshAir filter
Comfort and flexibility		Divisible glass shelf	Divisible glass shelf
		VarioSafe	SoftSystem soft closing mechanism VarioSafe
			VarioBoxes
			Butter dish
	Egg tray	Egg tray	Adjustable egg tray
	Bottle shelf	Bottle shelf	Bottle shelf
Design	Ceiling lighting	Ceiling or side lighting	LightTower Lighting BioFresh Safe
			SmartSteel rear wall
	Transparent glass	Transparent glass	Satin finish glass
	Stainless steel look shelves	Stainless steel look shelves	Glass & stainless steel rack
	Touch display	Touch display	Touch & Swipe display
	Display behind the door	Display behind the door	Display behind the door
	Recessed grip	Recessed grip	Slimline door handle with opening mechanism
Connectivity (SmartDeviceBox)	Can be retrofitted	Can be retrofitted	Can be retrofitted

Differentiating equipment is **highlighted** in the next higher series.

Quality in every detail

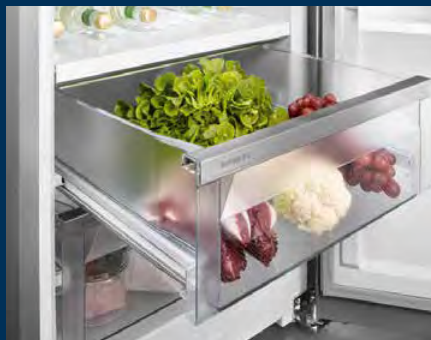

Fruit & Vegetable Safe

Crunchy salad and strawberries: the most delicate foods deserve a special place so they stay fresh longer – in BioFresh Safes. In the Fruit & Vegetable Safe the temperature is close to 0°C. Combined here with the constant humidity, thanks to the air-tight closure, unpackaged fruit and vegetables feel particularly at home. You do not have to adjust anything.



EasyFresh

The guarantee of market freshness in the home is our EasyFresh Safe. Whether it's unpackaged vegetables or fruit, this ensures optimal storage for everything. Thanks to the air-tight closure, the food causes the humidity in the safe to rise. This keeps the food fresher for longer.



LED side lighting, single sided

For a quick overview of everything in the refrigerator: the LED side lighting helps you to keep your food in view. The LEDs are positioned so that the light beams go up and down. And the LEDs integrated flush into the side walls mean that the valuable usable area is fully maintained.

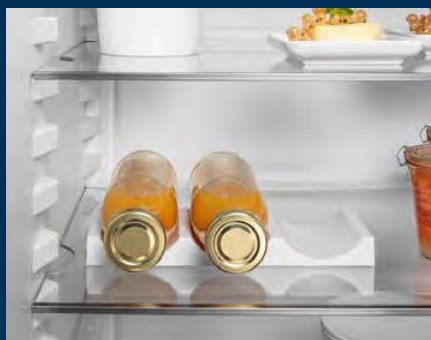

3 bottle shelf

Now your bottles stay where they should. The 3 bottle shelf securely holds three bottles in your fridge ready to be used. The bottle shelf fits on every glass shelf and is therefore very flexible. And if you need the space for other reasons, simply take the bottle shelf out of the fridge.



LightTower

Enjoy an optimally illuminated interior: the LightTower shows off the food in its best light and is positioned so that all of your filled fridge is illuminated at all times. The flush mounting of the LightTower in the side walls means there is also more space for your food.



Door hinge exchange, integrated freezer compartment

Switch the opening direction on your 4* freezer compartment door quickly and easily: The clever slide control means this can be done in seconds and without any manual skills. Simply slide the control on the 4* freezer compartment right or left – that's it, done.

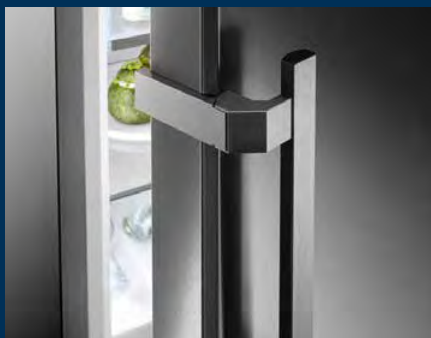

Slimline door handle with integrated opening mechanism

Opening made easy: The practical and elegant slimline door handle with an integrated opening mechanism allows you to open the appliance door effortlessly, even when it's opened multiple times in quick succession. The classy, minimalistic handles are also an eye-catcher on your appliance.



Door shelf

Do you want a safe storage area for your drinks or food? And do you still want to reach them easily? Our height-adjustable door shelves offer you both – thanks to the safety glass shelves and stainless steel rails. The sliding and removable bottle holder also ensures that your bottles are held securely.



Bottle shelf above the BioFresh Safe

Expecting guests and want to chill a few more drinks than usual? The bottle shelf above the BioFresh Safes exists for this very reason. Simply remove the glass shelf above the bottle shelf in one easy step – and you can now safely store and cool bottles of various sizes.



SoftTelescopic

Look forward to opening your BioFresh safes. And this is not just because of the fresh food – but also because opening is so easy, and closing is cushioned. The telescopic rails slide the safe gently towards you. And because these extend fully, you have the best overview of the contents.



FlexSystem

Small and delicate fruit in the refrigerator can easily roll out of sight or become crushed. That's why your Liebherr comes with the FlexSystem. Two flexibly positionable boxes in the BioFresh Safe ensure everything is clearly arranged and organised. And they also safely protect even the smallest raspberry from bruising or from being mixed up with other foods.



Space for baking tray

Do you want to keep that home-baked fruit pie fresh? Or maybe a prepared pizza to be baked later on? If so, simply slide your baking tray into your Liebherr – it has plenty of space. Really convenient – you can slide the baking tray in and out when the door is opened at 90°.

BioFresh fridges



Fruit & Vegetable Safe

Crunchy salad and strawberries: the most delicate foods deserve a special place so they stay fresh longer – in BioFresh Safes. In the Fruit & Vegetable Safe the temperature is close to 0°C. Combined here with the constant humidity, thanks to the air-tight closure, unpackaged fruit and vegetables feel particularly at home. You do not have to adjust anything.



SoftTelescopic

Look forward to opening your BioFresh Safes. And this is not just because of the fresh food – but also because opening is so easy, and closing is cushioned. The telescopic rails slide the safe gently towards you. And because these extend fully, you have the best overview of the contents.



← 60 →



RBsdc 525i

Prime

Energy efficiency class:	C ^A / _B / _G ¹
Energy consumption year / 24 hrs:	108 / 0.295 kWh ¹
Total volume ² :	386 l
Volume:	Fridge: 245.8 l / BioFresh compartment: 140.9 l
Noise output / noise class:	33 dB(A) / B, SuperSilent
Climate rating:	SN-T (from +10 °C to +43 °C)
Door / side walls:	SmartSteel / silver
Exterior dimensions in cm (h / w / d):	185.5 / 59.7 / 67.5 ¹

Bio Fresh	Super Cool	Glass & Steel Interior	Light Tower	Soft System	Soft-Telescopic Rails	Super Silent	Touch & Swipe Display	Smart Device
-----------	------------	------------------------	-------------	-------------	-----------------------	--------------	-----------------------	--------------

Controls

- 2.4" TFT-colour display behind-the-door, touch- & swipe
- Digital temperature display for fridge and BioFresh compartments
- SmartDeviceBox included
- Door alarm: visual and acoustic

Fridge and BioFresh compartments

- PowerCooling with FreshAir activated charcoal filter
- Premium GlassLine storage shelves with bottle holder, removable VarioBoxes, adjustable egg tray, butter dish
- 4 GlassLine storage shelves, of which 1 is divided into two parts
- VarioSafe
- Integrated bottle shelf
- LED light panel, both sides
- LED BioFresh lighting
- 3 BioFresh Safes with SoftTelescopic, 2 Fruit & Vegetable Safes, 1 Meat & Dairy Safe

Key features

- Slimline handle with integrated opening mechanism
- Transport handles, front and at back, transport castors at back
- Height-adjustable feet at front
- Reversible door hinging, right
- Replaceable door seal
- Dry rear wall in stainless steel with SmartSteel

¹ To achieve the indicated energy consumption level, the wall spacers provided with the appliance must be used. These increase the appliance depth by approximately 1.5 cm. If the wall spacers are not used, the appliance will remain fully functional, but will have a slightly higher energy consumption level.



Bottle shelf above the BioFresh Safe

Expecting guests and want to chill a few more drinks than usual? The bottle shelf above the BioFresh Safes exists for this very reason. Simply remove the glass shelf above the bottle shelf in one easy step – and you can now safely store and cool bottles of various sizes.



Space for baking tray

Do you want to keep that home-baked fruit pie fresh? Or maybe a prepared pizza to be baked later on? If so, simply slide your baking tray into your Liebherr – it has plenty of space. Really convenient – you can slide the baking tray in and out when the door is opened at 90°.



← 60 →



RBc 5220

Plus

Energy efficiency class:	
Energy consumption year / 24 hrs:	101 / 0.276 kWh ¹
Total volume ² :	382 l
Volume:	Fridge: 288.7 l / BioFresh compartment: 93.7 l
Noise output / noise class:	34 dB(A) / B, SuperSilent
Climate rating:	SN-T (from +10 °C to +43 °C)
Door / side walls:	white / white
Exterior dimensions in cm (h / w / d):	185.5 / 59.7 / 67.5 ¹



Controls

- LC monochrome display behind-the-door, touch electronic
- Digital temperature display for fridge compartment
- SmartDeviceBox: optional accessory
- Door alarm: visual and acoustic

Fridge and BioFresh compartments

- PowerCooling with FreshAir activated charcoal filter
- Plastic door shelves with bottle holder, egg tray, FlexCube
- 6 GlassLine storage shelves, of which 1 is divided into two parts
- VarioSafe
- Integrated bottle shelf
- LED ceiling lighting
- 2 BioFresh Safes with telescopic partial pull-out, 1 Fruit & Vegetable Safe, 1 Meat & Dairy Safe

Key features

- Vertical recessed handle
- Transport handles, front and at back, transport castors at back
- Height-adjustable feet at front
- Reversible door hinging, right
- Replaceable door seal

² In accordance with Regulation EU 2019/2016 we indicate the total volume to the nearest integer (rounded off) and the volume of the frozen compartments and refrigeration compartments to one place after the decimal point. You can find the full range of efficiency classes at page 15. According to (EU) 2017/1369 6a.



RBa30 425i ◊ Prime series



BioFresh

BioFresh guarantees the perfect temperature for much longer freshness. At a temperature of just over 0°C and with the ideal humidity, fresh food can keep its appetising appearance and retain healthy vitamins and minerals for considerably longer than in a normal fridge compartment. While the DrySafe is particularly suitable for storing meat, fish and dairy products, the high humidity in the Fruit & Vegetable Safe can prevent fruit and vegetables from drying out and helps preserve stored goods for an even longer period.



LED lighting

The LED lighting ensures your BioFresh Safes are pleasantly lit. This makes it even easier for you to find the food you want. The energy-efficient LED unit is elegantly positioned above the safes to save space.



← 60 →



RBa30 425i

Prime

Energy efficiency class:	A ¹
Energy consumption year / 24 hrs:	65 / 0.178 kWh ¹
Total volume ² :	160 l
Noise output / noise class:	34 dB(A) / B, SuperSilent
Climate rating:	SN-T (from +10 °C to +43 °C)
Door / side walls:	white / white
Exterior dimensions in cm (h / w / d):	125.5 / 59.7 / 67.5 ¹



Controls

- 2.4" TFT-colour display behind-the-door, touch- & swipe
- Digital temperature display
- SmartDeviceBox included
- Door alarm: visual and acoustic

Fridge and BioFresh compartments

- Ventilator
- LED BioFresh lighting
- 4 BioFresh Safes on integrated drawer guide

Key features

- Slimline handle with integrated opening mechanism
- Transport handles, front and at back, transport castors at back
- Height-adjustable feet at front
- Reversible door hinging, right
- Replaceable door seal

¹ To achieve the indicated energy consumption level, the wall spacers provided with the appliance must be used. These increase the appliance depth by approximately 1.5 cm. If the wall spacers are not used, the appliance will remain fully functional, but will have a slightly higher energy consumption level.

² In accordance with Regulation EU 2019/2016 we indicate the total volume to the nearest integer (rounded off) and the volume of the frozen compartments and refrigeration compartments to one place after the decimal point.

You can find the full range of efficiency classes at page 15. According to (EU) 2017/1369 6a.

EasyFresh fridges



← 60 →

Rd 5220

Plus



Energy efficiency class:	
Energy consumption year / 24 hrs:	98 / 0.268 kWh ¹
Total volume ² :	399 l
Noise output / noise class:	35 dB(A) / B, SuperSilent
Climate rating:	SN-T (from +10 °C to +43 °C)
Door / side walls:	white / white
Exterior dimensions in cm (h / w / d):	185.5 / 59.7 / 67.5 ¹



Controls

- LC monochrome display behind-the-door, touch electronic
- Digital temperature display
- SmartDeviceBox: optional accessory
- Door alarm: visual and acoustic

Fridge compartment

- PowerCooling with FreshAir activated charcoal filter
- Plastic door shelves with bottle holder, egg tray, FlexCube
- 6 GlassLine storage shelves, of which 1 is divided into two parts
- VarioSafe
- Bottle shelf
- LED ceiling lighting
- 1 EasyFresh Safe on running rails

Key features

- Vertical recessed handle
- Transport handles, front and at back, transport castors at back
- Height-adjustable feet at front
- Reversible door hinging, right
- Replaceable door seal



← 60 →

Rd 5000

Pure



Energy efficiency class:	
Energy consumption year / 24 hrs:	93 / 0.254 kWh ¹
Total volume ² :	348 l
Noise output / noise class:	36 dB(A) / C
Climate rating:	SN-T (from +10 °C to +43 °C)
Door / side walls:	white / white
Exterior dimensions in cm (h / w / d):	165.5 / 59.7 / 67.5 ¹



Controls

- LC monochrome display behind-the-door, touch electronic
- Digital temperature display
- SmartDeviceBox: optional accessory
- Door alarm: visual and acoustic

Fridge compartment

- PowerCooling with FreshAir activated charcoal filter
- Plastic door shelves with bottle holder, egg tray
- 7 GlassLine storage shelves
- LED ceiling lighting
- 1 EasyFresh Safe on running rails

Key features

- Vertical recessed handle
- Transport handles, front and at back, transport castors at back
- Height-adjustable feet at front
- Reversible door hinging, right
- Replaceable door seal

¹ To achieve the indicated energy consumption level, the wall spacers provided with the appliance must be used. These increase the appliance depth by approximately 1.5 cm / 3.5 cm. If the wall spacers are not used, the appliance will remain fully functional, but will have a slightly higher energy consumption level.



← 60 →

Rd 4600 Pure



Energy efficiency class:	
Energy consumption year / 24 hrs:	89 / 0.243 kWh ¹
Total volume ² :	298 l
Noise output / noise class:	37 dB(A) / C
Climate rating:	SN-T (from +10 °C to +43 °C)
Door / side walls:	white / white
Exterior dimensions in cm (h / w / d):	145.5 / 59.7 / 67.5 ¹



Controls

- LC monochrome display behind-the-door, touch electronic
- Digital temperature display
- SmartDeviceBox: optional accessory
- Door alarm: visual and acoustic

Fridge compartment

- PowerCooling with FreshAir activated charcoal filter
- Plastic door shelves with bottle holder, egg tray
- 6 GlassLine storage shelves
- LED ceiling lighting
- 1 EasyFresh Safe on running rails

Key features

- Vertical recessed handle
- Transport handles, front and at back, transport castors at back
- Height-adjustable feet at front
- Reversible door hinging, right
- Replaceable door seal



← 60 →

Rd 4200 Pure



Energy efficiency class:	
Energy consumption year / 24 hrs:	84 / 0.230 kWh ¹
Total volume ² :	247 l
Noise output / noise class:	37 dB(A) / C
Climate rating:	SN-T (from +10 °C to +43 °C)
Door / side walls:	white / white
Exterior dimensions in cm (h / w / d):	125.5 / 59.7 / 67.5 ¹



Controls

- LC monochrome display behind-the-door, touch electronic
- Digital temperature display
- SmartDeviceBox: optional accessory
- Door alarm: visual and acoustic

Fridge compartment

- PowerCooling with FreshAir activated charcoal filter
- Plastic door shelves with bottle holder, egg tray
- 5 GlassLine storage shelves
- LED ceiling lighting
- 1 EasyFresh Safe on running rails

Key features

- Vertical recessed handle
- Transport handles, front and at back, transport castors at back
- Height-adjustable feet at front
- Reversible door hinging, right
- Replaceable door seal

² In accordance with Regulation EU 2019/2016 we indicate the total volume to the nearest integer (rounded off) and the volume of the frozen compartments and refrigeration compartments to one place after the decimal point. You can find the full range of efficiency classes at page 15. According to (EU) 2017/1369 6a.

Under counter fridges



Rsdci 1621 ◇ Plus series

Quality in every detail



DoorStop

Keep your Liebherr fresh and odour-free with our retractable DoorStop. Prevents odours by keeping the door open when not in use. Save time and energy.



LED side lighting

The LED side lighting illuminates the interior from the side – providing a good overview of your food. Another highlight: the LEDs are positioned in front of the glass shelves so that even a full refrigerator is well lit.



EasyFresh Safe

The guarantee of market freshness in the home is our EasyFresh Safe. Whether it's unpackaged vegetables or fruit, this ensures optimal storage for everything. Thanks to the air-tight closure, the food causes the humidity in the safe to rise. This keeps the food fresh for a long time.

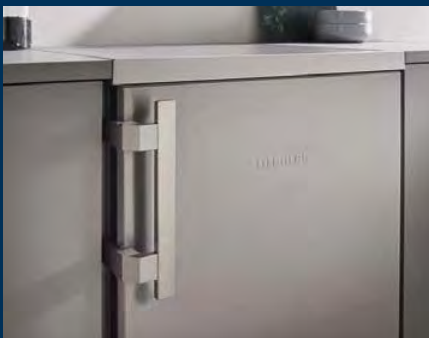

Slimline door handle with integrated opening mechanism

The sturdy, secure handles have an elegant, premium quality appearance and feature an integrated opening mechanism, which allows convenient and effortless door opening.



Height-adjustable inner door shelves

Use all of the space in your Liebherr – and entirely to suit your requirements. The height adjustable inner door shelves will help with this: These allow you to change the height at which the shelves are mounted quickly and easily at any time – which means they can be used entirely flexibly and securely for storing a wide range of containers and foodstuffs.



TouchControl

A gentle finger tap and you set your Liebherr to 3, 5, 7 or 9°C with TouchControl. So simple – and efficient, as the sleek button is integrated into the interior, creating more space for all your fresh goods.

EasyFresh under counter fridges



← 60 →

Rsdci 1621

Plus

Energy efficiency class:	
Energy consumption year / 24 hrs:	95 / 0.260 kWh ¹
Total volume ² :	125 l
Volume:	Fridge: 109.2 l / Freezer compartment: 17 l
Noise output / noise class:	35 dB(A) / B, SuperSilent
Climate rating:	SN-T (from +10 °C to +43 °C)
Door / side walls:	SmartSteel / silver
Exterior dimensions in cm (h / w / d):	85 / 60 / 60.7 ¹



Controls

- TouchControl in the interior, touch electronic
- Digital temperature display
- SmartDeviceBox included
- Alarm in case of malfunction: visual and acoustic
- Door alarm: visual and acoustic

Fridge compartment

- Plastic door shelves with bottle holder, egg tray, FlexCube
- 3 GlassLine storage shelves, of which 1 is divided into two parts
- 3-bottle shelf
- LED lighting
- 1 EasyFresh Safe

Freezer compartment **4*****

- Hinged 4-star freezer compartment door
- Temperature rise time: 10 h
- Freezing capacity in 24 hrs: 2 kg

Key features

- Slimline handle with integrated opening mechanism
- Height-adjustable feet at front
- Reversible door hinging, right
- Replaceable door seal



← 60 →

Rsdci 1620

Plus

Energy efficiency class:	
Energy consumption year / 24 hrs:	59 / 0.161 kWh ¹
Total volume ² :	141 l
Noise output / noise class:	34 dB(A) / B, SuperSilent
Climate rating:	SN-T (from +10 °C to +43 °C)
Door / side walls:	SmartSteel / silver
Exterior dimensions in cm (h / w / d):	85 / 60 / 60.7 ¹



Controls

- TouchControl in the interior, touch electronic
- Digital temperature display
- SmartDeviceBox included
- Alarm in case of malfunction: visual and acoustic
- Door alarm: visual and acoustic

Fridge compartment

- Plastic door shelves with bottle holder, egg tray, FlexCube
- 4 GlassLine storage shelves, of which 1 is divided into two parts
- 3-bottle shelf
- LED lighting
- 1 EasyFresh Safe

Key features

- Slimline handle with integrated opening mechanism
- Height-adjustable feet at front
- Reversible door hinging, right
- Replaceable door seal

¹ To achieve the indicated energy consumption level, the wall spacers provided with the appliance must be used. These increase the appliance depth by approximately 3.5 cm. If the wall spacers are not used, the appliance will remain fully functional, but will have a slightly higher energy consumption level.



← 60 →

Rdi 1621
Plus

Energy efficiency class:	
Energy consumption year / 24 hrs:	116 / 0.317 kWh¹
Total volume ² :	125 l
Volume:	Fridge: 109.2 l / Freezer compartment: 17 l
Noise output / noise class:	35 dB(A) / B, SuperSilent
Climate rating:	SN-T (from +10 °C to +43 °C)
Door / side walls:	white / white
Exterior dimensions in cm (h / w / d):	85 / 60 / 60.7¹

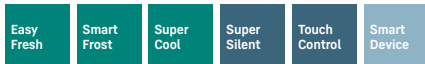

Controls

- TouchControl in the interior, touch electronic
- Digital temperature display
- SmartDeviceBox included
- Alarm in case of malfunction: visual and acoustic
- Door alarm: visual and acoustic

Fridge compartment

- Plastic door shelves with bottle holder, egg tray, FlexCube
- 3 GlassLine storage shelves, of which 1 is divided into two parts
- 3-bottle shelf
- LED lighting
- 1 EasyFresh Safe

Freezer compartment

- Hinged 4-star freezer compartment door
- Temperature rise time: 10 h
- Freezing capacity in 24 hrs: 2 kg

Key features

- Slimline handle with integrated opening mechanism
- Height-adjustable feet at front
- Reversible door hinging, right
- Replaceable door seal



← 60 →

Rdi 1620
Plus

Energy efficiency class:	
Energy consumption year / 24 hrs:	73 / 0.200 kWh¹
Total volume ² :	141 l
Noise output / noise class:	34 dB(A) / B, SuperSilent
Climate rating:	SN-T (from +10 °C to +43 °C)
Door / side walls:	white / white
Exterior dimensions in cm (h / w / d):	85 / 60 / 60.7¹



Controls

- TouchControl in the interior, touch electronic
- Digital temperature display
- SmartDeviceBox included
- Alarm in case of malfunction: visual and acoustic
- Door alarm: visual and acoustic

Fridge compartment

- Plastic door shelves with bottle holder, egg tray, FlexCube
- 4 GlassLine storage shelves, of which 1 is divided into two parts
- 3-bottle shelf
- LED lighting
- 1 EasyFresh Safe

Key features

- Slimline handle with integrated opening mechanism
- Height-adjustable feet at front
- Reversible door hinging, right
- Replaceable door seal

² In accordance with Regulation EU 2019/2016 we indicate the total volume to the nearest integer (rounded off) and the volume of the frozen compartments and refrigeration compartments to one place after the decimal point. You can find the full range of efficiency classes at page 15. According to (EU) 2017/1369 6a.

Under counter fridges



← 55 →

TK 14Vd00

Pure

Energy efficiency class:	D ¹ <small>A G</small>
Energy consumption year / 24 hrs:	72 / 0.197 kWh ¹
Total volume ² :	125 l
Noise output / noise class:	34 dB(A) / B, SuperSilent
Climate rating:	SN-T (from +10 °C to +43 °C)
Door / side walls:	white / white
Exterior dimensions in cm (h / w / d):	85 / 55 / 60.7 ¹



Controls

- TouchControl in the interior, touch electronic
- Digital temperature display
- Alarm in case of malfunction: visual and acoustic
- Door alarm: visual and acoustic

Fridge compartment

- Plastic door shelves with bottle holder, egg tray
- 3 GlassLine storage shelves
- LED lighting
- 1 spacious fruit and vegetable drawer

Key features

- Recessed handle
- Height-adjustable feet at front
- Reversible door hinging, right
- Replaceable door seal

Colour / material options:

Rd 1400 with Slimline handle with integrated opening mechanism



← 55 →

Re 1401

Pure

Energy efficiency class:	E ¹ <small>A G</small>
Energy consumption year / 24 hrs:	142 / 0.389 kWh ¹
Total volume ² :	111 l
Volume:	Fridge: 96.9 l / Freezer compartment: 15 l
Noise output / noise class:	37 dB(A) / C
Climate rating:	SN-T (from +10 °C to +43 °C)
Door / side walls:	white / white
Exterior dimensions in cm (h / w / d):	85 / 55 / 60.7 ¹



Controls

- TouchControl in the interior, touch electronic
- Digital temperature display
- Alarm in case of malfunction: visual and acoustic
- Door alarm: visual and acoustic

Fridge compartment

- Plastic door shelves with bottle holder, egg tray
- 2 GlassLine storage shelves
- LED lighting
- 1 spacious fruit and vegetable drawer

Freezer compartment ********

- Hinged 4-star freezer compartment door
- Temperature rise time: 10 h
- Freezing capacity in 24 hrs: 2 kg

Key features

- Slimline handle with integrated opening mechanism
- Height-adjustable feet at front
- Reversible door hinging, right
- Replaceable door seal



← 55 →

Re 1400

Pure

Energy efficiency class:	E ¹ <small>A G</small>
Energy consumption year / 24 hrs:	90 / 0.246 kWh ¹
Total volume ² :	125 l
Noise output / noise class:	35 dB(A) / B, SuperSilent
Climate rating:	SN-T (from +10 °C to +43 °C)
Door / side walls:	white / white
Exterior dimensions in cm (h / w / d):	85 / 55 / 60.7 ¹



Controls

- TouchControl in the interior, touch electronic
- Digital temperature display
- Alarm in case of malfunction: visual and acoustic
- Door alarm: visual and acoustic

Fridge compartment

- Plastic door shelves with bottle holder, egg tray
- 4 GlassLine storage shelves
- LED lighting
- 1 spacious fruit and vegetable drawer

Key features

- Slimline handle with integrated opening mechanism
- Height-adjustable feet at front
- Reversible door hinging, right
- Replaceable door seal

¹ To achieve the indicated energy consumption level, the wall spacers provided with the appliance must be used. These increase the appliance depth by approximately 3.5 cm. If the wall spacers are not used, the appliance will remain fully functional, but will have a slightly higher energy consumption level.



← 50 →

Rd 1201

Pure

Energy efficiency class:	
Energy consumption year / 24 hrs:	110 / 0.301 kWh¹
Total volume ² :	98 l
Volume:	Fridge: 85.2 l / Freezer compartment: 13 l
Noise output / noise class:	35 dB(A) / B, SuperSilent
Climate rating:	SN-T (from +10 °C to +43 °C)
Door / side walls:	white / white
Exterior dimensions in cm (h / w / d):	85 / 50 / 60.7¹



Controls

- TouchControl in the interior, touch electronic
- Digital temperature display
- Alarm in case of malfunction: visual and acoustic
- Door alarm: visual and acoustic

Fridge compartment

- Plastic door shelves with bottle holder, egg tray
- 2 GlassLine storage shelves
- LED lighting
- 1 spacious fruit and vegetable drawer

Freezer compartment ********

- Hinged 4-star freezer compartment door
- Temperature rise time: 8 h
- Freezing capacity in 24 hrs: 2 kg

Key features

- Recessed handle
- Height-adjustable feet at front
- Reversible door hinging, right
- Replaceable door seal



← 50 →

Rd 1200

Pure

Energy efficiency class:	
Energy consumption year / 24 hrs:	71 / 0.194 kWh¹
Total volume ² :	110 l
Noise output / noise class:	34 dB(A) / B, SuperSilent
Climate rating:	SN-T (from +10 °C to +43 °C)
Door / side walls:	white / white
Exterior dimensions in cm (h / w / d):	85 / 50 / 60.7¹



Controls

- TouchControl in the interior, touch electronic
- Digital temperature display
- Alarm in case of malfunction: visual and acoustic
- Door alarm: visual and acoustic

Fridge compartment

- Plastic door shelves with bottle holder, egg tray
- 4 GlassLine storage shelves
- LED lighting
- 1 spacious fruit and vegetable drawer

Key features

- Recessed handle
- Height-adjustable feet at front
- Reversible door hinging, right
- Replaceable door seal



← 50 →

Re 1200

Pure

Energy efficiency class:	
Energy consumption year / 24 hrs:	88 / 0.241 kWh¹
Total volume ² :	110 l
Noise output / noise class:	35 dB(A) / B, SuperSilent
Climate rating:	SN-T (from +10 °C to +43 °C)
Door / side walls:	white / white
Exterior dimensions in cm (h / w / d):	85 / 50 / 60.7¹



Controls

- TouchControl in the interior, touch electronic
- Digital temperature display
- Alarm in case of malfunction: visual and acoustic
- Door alarm: visual and acoustic

Fridge compartment

- Plastic door shelves with bottle holder, egg tray
- 4 GlassLine storage shelves
- LED lighting
- 1 spacious fruit and vegetable drawer

Key features

- Recessed handle
- Height-adjustable feet at front
- Reversible door hinging, right
- Replaceable door seal

Freezers



FNa 6625 ◇ Plus series



Range overview by appliance height and series

	← 60 →	← 60 →	← 60 →	← 60 →
	↑ 185 ↓	↑ 165 ↓	↑ 145 ↓	↑ 125 ↓
Freezers				
NoFrost				
EasyTwist-Ice	FNc 527i	FNb 505i FNd 5026	FNb 465i FNd 4625	FNb 425i FNd 4224 FNe 4204
	FNe 5207			
	← 70 →	← 70 →		
	↑ 185 ↓	↑ 145 ↓		
Freezers				
NoFrost	FNc 7227	FNa 6635 FNa 6625		
	← 60 →	← 55 →		
	↑ 85 ↓	↑ 85 ↓		
Under counter freezers				
NoFrost	FNdi 1624 FNsddi 1624	TGN 14Ve04		
SmartFrost	Fdi 1624	Fd 1404 Fe 1404		



FNb 505i ◯ Prime series

Freezers



○ Pure series



◇ Plus series



◻ Prime series



△ Peak series

	○ Pure series	◇ Plus series	◻ Prime series	△ Peak series
Freshness technology	NoFrost	NoFrost	NoFrost	NoFrost
Comfort and flexibility	EasyOpen	EasyOpen	EasyOpen	EasyOpen
	FrostProtect	FrostProtect	FrostProtect	FrostProtect
	Tipping drawer	Tipping drawer	Tipping drawer	Tipping drawer
	SpaceBox	SpaceBox	SpaceBox	SpaceBox
	Integrated drawer guide	Integrated drawer guide	Integrated drawer guide	Drawers guided on telescopic rails
		Ice cube tray		
		Freezer tray	Freezer tray	Freezer tray
			2 cold storage accumulators	2 cold storage accumulators
	VarioSpace	VarioSpace	VarioSpace	VarioSpace
Design			Status light	Status light
			Freezer compartment lighting	Freezer compartment lighting
				IceMaker lighting
	Touch display	Touch display	Touch & Swipe display	Touch & Swipe display
	Display behind the door	Display behind the door	Display behind the door	Display behind the door
	Recessed grip	Recessed grip	Slimline door handle with opening mechanism	Slimline door handle with opening mechanism
Connectivity (SmartDeviceBox)	Can be retrofitted	Can be retrofitted	Can be retrofitted or is included with "i" models	Can be retrofitted or is included with "i" models
Ice			EasyTwist-Ice	EasyTwist-Ice

Differentiating equipment is **highlighted** in the next higher series.

Quality in every detail



NoFrost

When you open your freezer, you want to see frozen food – and certainly not ice and frost. NoFrost protects the freezer compartment from unwanted icing, which consumes a lot of energy and can be expensive. NoFrost means no more tedious and time-consuming defrosting of the freezer compartment, more time for other things – and saving money.



SmartFrost

With the SmartFrost technology, ice build-up is greatly reduced. This makes defrosting rarely necessary. The interior walls of the freezer compartment are smooth and easy-to-clean offering additional capacity. Freezer drawers and glass shelves made of safety glass can be removed easily.



Touch & Swipe display

Control of your Liebherr at your fingertips: thanks to the Touch & Swipe display, you can operate your freezer intuitively and with ease. Simply select functions such as SuperFrost on the colour display by tapping and swiping. The temperature is controlled just as easily. And, what if you are not actively using the display? It then shows you the actual temperature.



IceTower

You will never run out of cold drinks at your party. The IceTower, which holds 8 kg of ice cubes, makes sure of that. The ice cube scoop and the pull-out tray on telescopic rails allow easy access to the ice cubes. An extra insert tray means you can also store less ice and make room for frozen food underneath. The adjacent drawer provides storage space for frozen goods.



Status display

You want to check that everything is OK with your appliance? The status display on the appliance door lets you know very quickly, visually and audibly. A blue light indicates: everything is OK. If the status is anything but OK, the display lights up red and flashes. A warning tone also sounds.



LED freezer compartment lighting

When you open the drawers in your Liebherr freezer, not only are you welcomed by the sight of your food, but also by the attractive lighting. This is provided by powerful, long-life, environmentally-friendly LEDs. The lighting makes it even easier to see all of the contents and is also a unique design element.



FrostProtect

Not all freezers are fitted in heated rooms. Some are located in cold garages or sheds. It's good then that your Liebherr is ideally set up for such a cool environment because all components are designed to operate in ambient temperatures as low as -15 °C.



Cold storage accumulator

The cold storage accumulators are doubly useful - both indoors and outdoors. Inside the freezer, they keep the frozen food cold for a period should there be a power failure. And they are on hand to chill your food and drinks when you're on outings.



SpaceBox

Accommodate the "big stuff" in your Liebherr: An XL turkey or a multi-layered ice cream cake simply needs more space. Your Liebherr has the SpaceBox for exactly that purpose: At a generous height of 250 mm, it offers lots of extra space, even for large frozen goods. Helpful for you when storing food flexibly.



EasyTwist-Ice

Whether it's a summer day or a party: Thanks to EasyTwist-Ice, you can prepare a supply of ice cubes quickly and easily - without the need for a fixed water connection. Simply fill the tank with water, let it freeze and then release the finished ice cubes with a simple twist - and you're ready to serve cool drinks. The EasyTwist-Ice is easy to clean and ensures hygienic ice cube production at all times.



Ice cube scoop

The Liebherr ice scoop makes portioning and transporting of ice easy. Thanks to the slanted tip and the ergonomic handle, ice cubes can make it from your IceTower into your drinks quickly and easily. The robust ice scoop made of sturdy plastic is also pleasing to the eye thanks to its satin surface in transparent glacier green.



VarioSpace

Want to store a multi-layer ice cream cake safely until the summer party? No problem for your Liebherr freezer: Sometimes you just need more space and it's prepared for just that. With VarioSpace you can remove individual freezer drawers and the horizontal glass dividers below them, and hey presto, you have an extra large storage space.

NoFrost freezers



NoFrost

When you open your freezer, you want to see frozen food – and certainly not ice and frost. NoFrost protects the freezer compartment from unwanted icing, which consumes a lot of energy and can be expensive. NoFrost means no more tedious and time-consuming defrosting of the freezer compartment, more time for other things – and saving money.



FrostProtect

Not all freezers are fitted in heated rooms. Some are located in cold garages or sheds. It's good then that your Liebherr is ideally set up for such a cool environment because all components are designed to operate in ambient temperatures as low as -15 °C.



← 70 →



FNC 7227 Plus

Energy efficiency class:	C ¹
Energy consumption year / 24 hrs:	178 / 0.487 kWh ¹
Total volume ² :	363 l
Noise output / noise class:	36 dB(A) / C
Climate rating:	SN-T (from +10 °C to +43 °C)
Designed to operate in ambient temperatures:	as low as -15 °C
Door / side walls:	white / white
Exterior dimensions in cm (h / w / d):	185.5 / 69.7 / 76 ¹



Controls

- LC monochrome display behind-the-door, touch electronic
- Digital temperature display
- SmartDeviceBox: optional accessory
- Alarm in case of malfunction: visual and acoustic
- Door alarm: visual and acoustic

Freezer compartment *******

- 7 drawers on integrated drawer guide, VarioSpace
- Top drawer with convenient tilting function
- Ice cube tray
- Temperature rise time: 19 h
- Freezing capacity in 24 hrs: 19 kg

Key features

- Vertical recessed handle
- Transport handles, front and at back, transport castors at back
- Height-adjustable feet at front
- Reversible door hinging, right
- Replaceable door seal

¹ To achieve the indicated energy consumption level, the wall spacers provided with the appliance must be used. These increase the appliance depth by approximately 1.5 cm. If the wall spacers are not used, the appliance will remain fully functional, but will have a slightly higher energy consumption level.



The FNa 6625: the first in its class.

Our 146-cm-tall freezer is rated as energy efficiency class A, the best that is currently available on the market. High-quality vacuum insulation panels with silica (silicic acid), sophisticated electronics and a powerful compressor make it more energy-efficient than any other appliance with conventional insulation. Its NoFrost technology and five drawers ensure long-term freshness and plenty of freezer space.

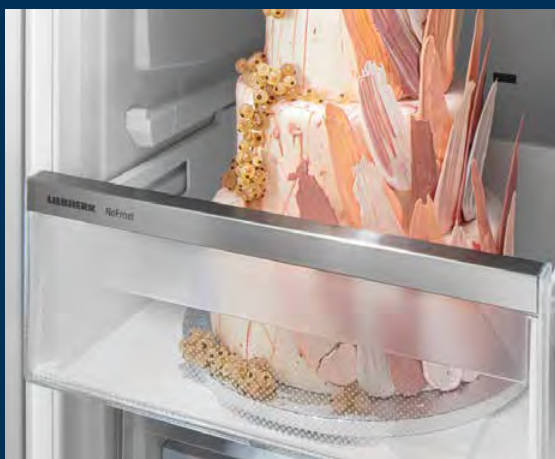

VarioSpace

Want to store a multi-layer ice cream cake safely until the summer party? No problem for your Liebherr freezer: Sometimes you just need more space and it's prepared for just that. With VarioSpace you can remove individual freezer drawers and the horizontal glass dividers below them, and hey presto, you have an extra large storage space.



← 70 →



FNa 6625

Plus

Energy efficiency class:	A ¹
Energy consumption year / 24 hrs:	99 / 0.271 kWh¹
Total volume ² :	260 l
Noise output / noise class:	33 dB(A) / B, SuperSilent
Climate rating:	SN-T (from +10 °C to +43 °C)
Designed to operate in ambient temperatures:	as low as -15 °C
Door / side walls:	white / white
Exterior dimensions in cm (h / w / d):	145.5 / 69.7 / 76¹

No Frost	Super Frost	Super Silent	Touch Display	VarioSpace	Easy Open	Frost Protect	Smart Device Ready
----------	-------------	--------------	---------------	------------	-----------	---------------	--------------------

Controls

- LC monochrome display behind-the-door, touch electronic
- Digital temperature display
- SmartDeviceBox: optional accessory
- Alarm in case of malfunction: visual and acoustic
- Door alarm: visual and acoustic

Freezer compartment *********

- 5 drawers on integrated drawer guide, VarioSpace
- Ice cube tray
- Temperature rise time: 18 h
- Freezing capacity in 24 hrs: 17 kg

Key features

- Vertical recessed handle
- Transport handles, front and at back, transport castors at back
- Height-adjustable feet at front
- Reversible door hinging, right
- Replaceable door seal

Colour / material options:

FNa 6635 available by special order

² In accordance with Regulation EU 2019/2016 we indicate the total volume to the nearest integer (rounded off) and the volume of the frozen compartments and refrigeration compartments to one place after the decimal point. You can find the full range of efficiency classes at page 15. According to (EU) 2017/1369 6a.

NoFrost freezers



← 60 →



← 60 →



← 60 →



FNC 527i Peak

Energy efficiency class:



Energy consumption year / 24 hrs: **159 / 0.435 kWh¹**

Total volume²: **277 l**

Noise output / noise class: **33 dB(A) / B, SuperSilent**

Climate rating: **SN-T (from +10 °C to +43 °C)**

Designed to operate in ambient temperatures: **as low as -15 °C**

Door / side walls: **white / white**

Exterior dimensions in cm (h / w / d): **185.5 / 59.7 / 67.5¹**

No Frost	Super Frost	LED	Easy Twist Ice	Telescopic Rails	Super Silent
Touch & Swipe Display	Space Box	Vario Space	Easy Open	Frost Protect	Smart Device

Controls

- 2.4" TFT-colour display behind-the-door, touch- & swipe
- Digital temperature display
- SmartDeviceBox included
- Alarm in case of malfunction: visual and acoustic
- Door alarm: visual and acoustic

Freezer compartment **★☆☆**

- 7 drawers, of which 5 with telescopic partial pull-out, VarioSpace
- Top drawer with convenient tilting function
- EasyTwist-Ice
- LED lighting
- Status indicator
- Temperature rise time: 16 h
- Freezing capacity in 24 hrs: 18 kg
- 1 cold storage accumulator
- Safety glass fittings

Key features

- Slimline handle with integrated opening mechanism
- Transport handles, front and at back, transport castors at back
- Height-adjustable feet at front
- Reversible door hinging, right
- Replaceable door seal



FNe 5207 Pure

Energy efficiency class:



Energy consumption year / 24 hrs: **249 / 0.682 kWh¹**

Total volume²: **277 l**

Noise output / noise class: **36 dB(A) / C**

Climate rating: **SN-T (from +10 °C to +43 °C)**

Designed to operate in ambient temperatures: **as low as -15 °C**

Door / side walls: **white / white**

Exterior dimensions in cm (h / w / d): **185.5 / 59.7 / 67.5¹**

No Frost	Super Frost	Touch Display	Space Box	Vario Space	Easy Open
Frost Protect	Smart Device Ready				

Controls

- LC monochrome display behind-the-door, touch electronic
- Digital temperature display
- SmartDeviceBox: optional accessory
- Alarm in case of malfunction: visual and acoustic
- Door alarm: visual and acoustic

Freezer compartment **★☆☆**

- 7 drawers on integrated drawer guide, VarioSpace
- Top drawer with convenient tilting function
- Temperature rise time: 16 h
- Freezing capacity in 24 hrs: 18 kg

Key features

- Vertical recessed handle
- Transport handles, front and at back, transport castors at back
- Height-adjustable feet at front
- Reversible door hinging, right
- Replaceable door seal



FNd 5026 Plus

Energy efficiency class:



Energy consumption year / 24 hrs: **188 / 0.515 kWh¹**

Total volume²: **238 l**

Noise output / noise class: **36 dB(A) / C**

Climate rating: **SN-T (from +10 °C to +43 °C)**

Designed to operate in ambient temperatures: **as low as -15 °C**

Door / side walls: **white / white**

Exterior dimensions in cm (h / w / d): **165.5 / 59.7 / 67.5¹**

No Frost	Super Frost	Touch Display	Space Box	Vario Space	Easy Open
Frost Protect	Smart Device Ready				

Controls

- LC monochrome display behind-the-door, touch electronic
- Digital temperature display
- SmartDeviceBox: optional accessory
- Alarm in case of malfunction: visual and acoustic
- Door alarm: visual and acoustic

Freezer compartment **★☆☆**

- 6 drawers on integrated drawer guide, VarioSpace
- Top drawer with convenient tilting function
- Ice cube tray
- Temperature rise time: 16 h
- Freezing capacity in 24 hrs: 17 kg

Key features

- Vertical recessed handle
- Transport handles, front and at back, transport castors at back
- Height-adjustable feet at front
- Reversible door hinging, right
- Replaceable door seal

¹ To achieve the indicated energy consumption level, the wall spacers provided with the appliance must be used. These increase the appliance depth by approximately 1.5 cm. If the wall spacers are not used, the appliance will remain fully functional, but will have a slightly higher energy consumption level.

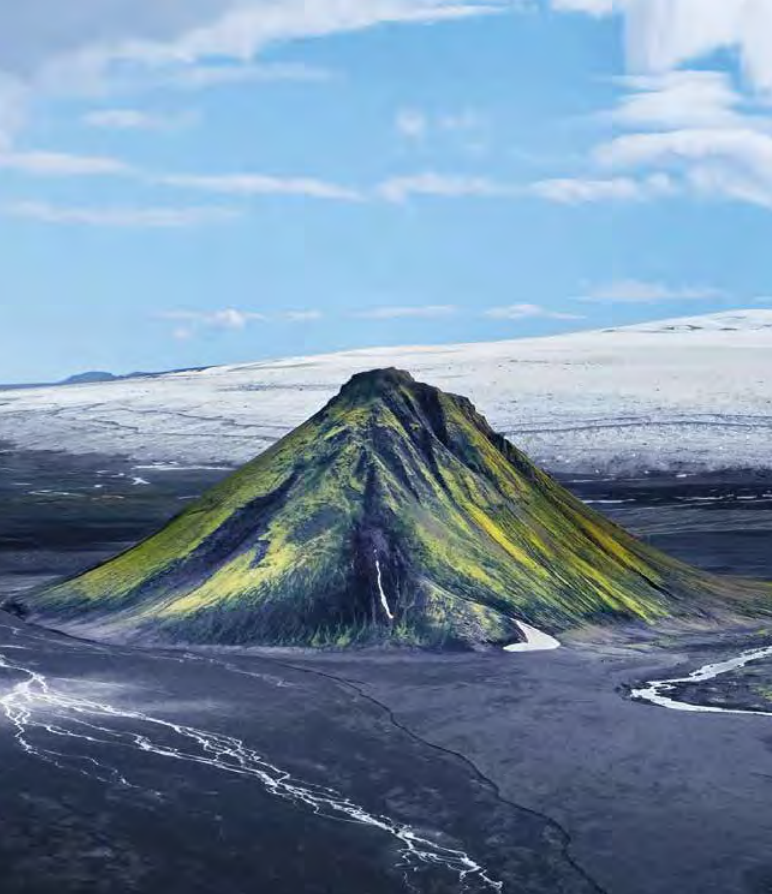

← 60 →

FNb 505i
Prime

Unveiled in the Liebherr FNb 505i

BluRoX can first be seen in the Liebherr FNb 505i. In the door of this freezer, the innovative vacuum insulation celebrates a very special world first: in accordance with the new EU energy label, the Liebherr FNb 505i is the first freezer of its type to be awarded efficiency class "B". And to ensure this remains the case for many years, the high-quality insulation also boasts the durability that Liebherr is renowned for.



To learn more about this exciting technology and the many advantages of BluRoX, visit: home.liebherr.com/blurox

Energy efficiency class:	B <small>A⁺ G</small> ¹
Energy consumption year / 24 hrs:	120 / 0.328 kWh¹
Total volume ² :	238 l
Noise output / noise class:	31 dB(A) / B, SuperSilent
Climate rating:	SN-T (from +10 °C to +43 °C)
Designed to operate in ambient temperatures:	as low as -15 °C
Door / side walls:	white / white
Exterior dimensions in cm (h / w / d):	165.5 / 59.7 / 65.5¹

No Frost	Super Frost	LED	Easy Twist Ice	Super Silent	Touch & Swipe Display	Space Box	VarioSpace	Easy Open
Frost Protect	Smart Device							

Controls

- 2.4" TFT-colour display behind-the-door, touch- & swipe
- Digital temperature display
- SmartDeviceBox included
- Alarm in case of malfunction: visual and acoustic
- Door alarm: visual and acoustic

Freezer compartment ********

- 6 drawers on integrated drawer guide, VarioSpace
- Top drawer with convenient tilting function
- EasyTwist-Ice
- LED lighting
- Status indicator
- Temperature rise time: 16 h
- Freezing capacity in 24 hrs: 17 kg
- 1 cold storage accumulator

Key features

- Slimline handle with integrated opening mechanism
- Transport handles, front and at back, transport castors at back
- Height-adjustable feet at front
- Reversible door hinging, right
- Replaceable door seal

² In accordance with Regulation EU 2019/2016 we indicate the total volume to the nearest integer (rounded off) and the volume of the frozen compartments and refrigeration compartments to one place after the decimal point. You can find the full range of efficiency classes at page 15. According to (EU) 2017/1369 6a.

NoFrost freezers



← 60 →

FNb 465i
Prime



Energy efficiency class:	B ^A / _G ¹
Energy consumption year / 24 hrs:	113 / 0.309 kWh ¹
Total volume ² :	199 l
Noise output / noise class:	33 dB(A) / B, SuperSilent
Climate rating:	SN-T (from +10 °C to +43 °C)
Designed to operate in ambient temperatures:	as low as -15 °C
Door / side walls:	white / white
Exterior dimensions in cm (h / w / d):	145.5 / 59.7 / 67.5 ¹

No Frost	Super Frost	LED	Easy Twist Ice	Super Silent	Touch & Swipe Display	Space Box	Vario Space	Easy Open
Frost Protect	Smart Device							

Controls

- 2.4" TFT-colour display behind-the-door, touch- & swipe
- Digital temperature display
- SmartDeviceBox included
- Alarm in case of malfunction: visual and acoustic
- Door alarm: visual and acoustic

Freezer compartment **★★★★**

- 5 drawers on integrated drawer guide, VarioSpace
- EasyTwist-Ice
- LED lighting
- Status indicator
- Temperature rise time: 16 h
- Freezing capacity in 24 hrs: 16 kg
- 1 cold storage accumulator

Key features

- Slimline handle with integrated opening mechanism
- Transport handles, front and at back, transport castors at back
- Height-adjustable feet at front
- Reversible door hinging, right
- Replaceable door seal



← 60 →

FNd 4625
Plus



Energy efficiency class:	D ^A / _G ¹
Energy consumption year / 24 hrs:	177 / 0.484 kWh ¹
Total volume ² :	199 l
Noise output / noise class:	37 dB(A) / C
Climate rating:	SN-T (from +10 °C to +43 °C)
Designed to operate in ambient temperatures:	as low as -15 °C
Door / side walls:	white / white
Exterior dimensions in cm (h / w / d):	145.5 / 59.7 / 67.5 ¹

No Frost	Super Frost	Touch Display	Space Box	Vario Space	Easy Open	Frost Protect	Smart Device Ready
----------	-------------	---------------	-----------	-------------	-----------	---------------	--------------------

Controls

- LC monochrome display behind-the-door, touch electronic
- Digital temperature display
- SmartDeviceBox: optional accessory
- Alarm in case of malfunction: visual and acoustic
- Door alarm: visual and acoustic

Freezer compartment **★★★★**

- 5 drawers on integrated drawer guide, VarioSpace
- Ice cube tray
- Temperature rise time: 16 h
- Freezing capacity in 24 hrs: 16 kg

Key features

- Vertical recessed handle
- Transport handles, front and at back, transport castors at back
- Height-adjustable feet at front
- Reversible door hinging, right
- Replaceable door seal

¹ To achieve the indicated energy consumption level, the wall spacers provided with the appliance must be used. These increase the appliance depth by approximately 1.5 cm. If the wall spacers are not used, the appliance will remain fully functional, but will have a slightly higher energy consumption level.



← 60 →



← 60 →



← 60 →



FNb 425i

Prime

Energy efficiency class:	
Energy consumption year / 24 hrs:	106 / 0.290 kWh¹
Total volume ² :	160 l
Noise output / noise class:	33 dB(A) / B, SuperSilent
Climate rating:	SN-T (from +10 °C to +43 °C)
Designed to operate in ambient temperatures:	as low as -15 °C
Door / side walls:	white / white
Exterior dimensions in cm (h / w / d):	125.5 / 59.7 / 67.5¹

No Frost	Super Frost	LED	Easy Twist Ice	Super Silent	Touch & Swipe Display
Space Box	Vario Space	Easy Open	Frost Protect	Smart Device	

Controls

- 2.4" TFT-colour display behind-the-door, touch- & swipe
- Digital temperature display
- SmartDeviceBox included
- Alarm in case of malfunction: visual and acoustic
- Door alarm: visual and acoustic

Freezer compartment

- 4 drawers on integrated drawer guide, VarioSpace
- EasyTwist-Ice
- LED lighting
- Status indicator
- Temperature rise time: 15 h
- Freezing capacity in 24 hrs: 15 kg
- 1 cold storage accumulator

Key features

- Slimline handle with integrated opening mechanism
- Transport handles, front and at back, transport castors at back
- Height-adjustable feet at front
- Reversible door hinging, right
- Replaceable door seal



FNd 4224

Plus

Energy efficiency class:	
Energy consumption year / 24 hrs:	166 / 0.454 kWh¹
Total volume ² :	160 l
Noise output / noise class:	37 dB(A) / C
Climate rating:	SN-T (from +10 °C to +43 °C)
Designed to operate in ambient temperatures:	as low as -15 °C
Door / side walls:	white / white
Exterior dimensions in cm (h / w / d):	125.5 / 59.7 / 67.5¹

No Frost	Super Frost	Touch Display	Space Box	Vario Space	Easy Open
Frost Protect	Smart Device Ready				

Controls

- LC monochrome display behind-the-door, touch electronic
- Digital temperature display
- SmartDeviceBox: optional accessory
- Alarm in case of malfunction: visual and acoustic
- Door alarm: visual and acoustic

Freezer compartment

- 4 drawers on integrated drawer guide, VarioSpace
- Ice cube tray
- Temperature rise time: 15 h
- Freezing capacity in 24 hrs: 15 kg

Key features

- Vertical recessed handle
- Transport handles, front and at back, transport castors at back
- Height-adjustable feet at front
- Reversible door hinging, right
- Replaceable door seal



FNe 4204

Pure

Energy efficiency class:	
Energy consumption year / 24 hrs:	208 / 0.569 kWh¹
Total volume ² :	160 l
Noise output / noise class:	36 dB(A) / C
Climate rating:	SN-T (from +10 °C to +43 °C)
Designed to operate in ambient temperatures:	as low as -15 °C
Door / side walls:	white / white
Exterior dimensions in cm (h / w / d):	125.5 / 59.7 / 67.5¹

No Frost	Super Frost	Touch Display	Space Box	Vario Space	Easy Open
Frost Protect	Smart Device Ready				

Controls

- LC monochrome display behind-the-door, touch electronic
- Digital temperature display
- SmartDeviceBox: optional accessory
- Alarm in case of malfunction: visual and acoustic
- Door alarm: visual and acoustic

Freezer compartment

- 4 drawers on integrated drawer guide, VarioSpace
- Temperature rise time: 15 h
- Freezing capacity in 24 hrs: 15 kg

Key features

- Vertical recessed handle
- Transport handles, front and at back, transport castors at back
- Height-adjustable feet at front
- Reversible door hinging, right
- Replaceable door seal

² In accordance with Regulation EU 2019/2016 we indicate the total volume to the nearest integer (rounded off) and the volume of the frozen compartments and refrigeration compartments to one place after the decimal point. You can find the full range of efficiency classes at page 15. According to (EU) 2017/1369 6a.

Under counter NoFrost freezers



FNdi 1624

Plus

Energy efficiency class:	
Energy consumption year / 24 hrs:	148 / 0.405 kWh ¹
Total volume ² :	92 l
Noise output / noise class:	37 dB(A) / C
Climate rating:	SN-T (from +10 °C to +43 °C)
Designed to operate in ambient temperatures:	as low as -15 °C
Door / side walls:	white / white
Exterior dimensions in cm (h / w / d):	85 / 60 / 60.7 ¹



Controls

- TouchControl in the worktop, touch electronic
- Digital temperature display
- SmartDeviceBox included
- Alarm in case of malfunction: visual and acoustic
- Door alarm: visual and acoustic

Freezer compartment

- 4 drawers, VarioSpace
- Ice cube tray
- LED lighting
- Temperature rise time: 9.5 h
- Freezing capacity in 24 hrs: 8.5 kg
- Safety glass fittings

Key features

- Slimline handle with integrated opening mechanism
- Height-adjustable feet at front
- Reversible door hinging, right
- Replaceable door seal

Colour / material options:

FNsddi 1624 with Stainless steel front



TGN 14Ve04

Pure

Energy efficiency class:	
Energy consumption year / 24 hrs:	185 / 0.506 kWh ¹
Total volume ² :	92 l
Noise output / noise class:	37 dB(A) / C
Climate rating:	SN-T (from +10 °C to +43 °C)
Designed to operate in ambient temperatures:	as low as -15 °C
Door / side walls:	white / white
Exterior dimensions in cm (h / w / d):	85 / 55 / 60.7 ¹



Controls

- TouchControl in the worktop, touch electronic
- Digital temperature display
- Alarm in case of malfunction: visual and acoustic
- Door alarm: visual and acoustic

Freezer compartment

- 4 drawers, VarioSpace
- LED lighting
- Temperature rise time: 9 h
- Freezing capacity in 24 hrs: 7.5 kg
- Safety glass fittings

Key features

- Recessed handle
- Height-adjustable feet at front
- Reversible door hinging, right
- Replaceable door seal

¹ To achieve the indicated energy consumption level, the wall spacers provided with the appliance must be used. These increase the appliance depth by approximately 3.5 cm. If the wall spacers are not used, the appliance will remain fully functional, but will have a slightly higher energy consumption level.



Fdi 1624
Plus

Energy efficiency class:	D ¹
Energy consumption year / 24 hrs:	137 / 0.375 kWh ¹
Total volume ² :	107 l
Noise output / noise class:	36 dB(A) / C
Climate rating:	SN-T (from +10 °C to +43 °C)
Designed to operate in ambient temperatures:	as low as -15 °C
Door / side walls:	white / white
Exterior dimensions in cm (h / w / d):	85 / 60 / 60.7 ¹



Controls

- TouchControl in the worktop, touch electronic
- Digital temperature display
- SmartDeviceBox included
- Alarm in case of malfunction: visual and acoustic
- Door alarm: visual and acoustic

Freezer compartment ********

- 4 drawers, VarioSpace
- Ice cube tray
- LED lighting
- Temperature rise time: 14 h
- Freezing capacity in 24 hrs: 7.5 kg
- Safety glass fittings

Key features

- Slimline handle with integrated opening mechanism
- Height-adjustable feet at front
- Reversible door hinging, right
- Replaceable door seal



Fd 1404
Pure

Energy efficiency class:	D ¹
Energy consumption year / 24 hrs:	137 / 0.375 kWh ¹
Total volume ² :	107 l
Noise output / noise class:	37 dB(A) / C
Climate rating:	SN-T (from +10 °C to +43 °C)
Designed to operate in ambient temperatures:	as low as -15 °C
Door / side walls:	white / white
Exterior dimensions in cm (h / w / d):	85 / 55 / 60.7 ¹



Controls

- TouchControl in the worktop, touch electronic
- Digital temperature display
- Alarm in case of malfunction: visual and acoustic
- Door alarm: visual and acoustic

Freezer compartment ********

- 4 drawers, VarioSpace
- LED lighting
- Temperature rise time: 13.5 h
- Freezing capacity in 24 hrs: 7 kg
- Safety glass fittings

Key features

- Slimline handle with integrated opening mechanism
- Height-adjustable feet at front
- Reversible door hinging, right
- Replaceable door seal



Fe 1404
Pure

Energy efficiency class:	E ¹
Energy consumption year / 24 hrs:	172 / 0.471 kWh ¹
Total volume ² :	107 l
Noise output / noise class:	37 dB(A) / C
Climate rating:	SN-T (from +10 °C to +43 °C)
Designed to operate in ambient temperatures:	as low as -15 °C
Door / side walls:	white / white
Exterior dimensions in cm (h / w / d):	85 / 55 / 60.7 ¹



Controls

- TouchControl in the worktop, touch electronic
- Digital temperature display
- Alarm in case of malfunction: visual and acoustic
- Door alarm: visual and acoustic

Freezer compartment ********

- 4 drawers, VarioSpace
- LED lighting
- Temperature rise time: 12.5 h
- Freezing capacity in 24 hrs: 5.5 kg
- Safety glass fittings

Key features

- Slimline handle with integrated opening mechanism
- Height-adjustable feet at front
- Reversible door hinging, right
- Replaceable door seal

² In accordance with Regulation EU 2019/2016 we indicate the total volume to the nearest integer (rounded off) and the volume of the frozen compartments and refrigeration compartments to one place after the decimal point. You can find the full range of efficiency classes at page 15. According to (EU) 2017/1369 6a.

Quality in every detail

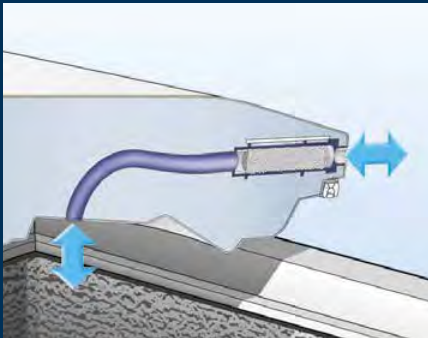

StopFrost

StopFrost prevents a vacuum from building up, ensuring the lid opens easily. Frosting over of the freezer and frozen food is reduced, which limits the number of times you need to defrost the freezer.



SmartFrost

With the SmartFrost technology, ice build-up is greatly reduced. This makes defrosting rarely necessary. The interior walls of the chest freezers are smooth and easy-to-clean offering additional capacity.



Condenser

The heat-exchange condenser is embedded in foam along the exterior wall, minimising vibration and promoting quieter operation. No condensation forms on the easy-to-clean outside walls.



FrostProtect

Due to their shape and size, many chest freezers are kept outside of the normal household environment so Liebherr has developed FrostProtect to enable these models to work in low ambient temperatures. All chest freezer models will work in ambient temperatures as low as -15°C .



LED interior light

The bright LED interior light allows a clear view of all your stored products even in low ambient lighting conditions. The one piece chest freezer lid and body is coated to ensure an excellent finish resilience and to prevent corrosion.



SuperFrost function

The automatic SuperFrost function quickly reduces the temperature to freeze your food while preserving the vitamins. As soon as the food is completely frozen, the automated SuperFrost function switches back to normal mode.



←168→

CFe 2500

Pure

Energy efficiency class:	
Energy consumption year / 24 hrs:	295 / 0.808 kWh
Total volume ¹ :	497 l
Noise output / noise class:	33 dB(A) / B, SuperSilent
Climate rating:	SN-T (from +10 °C to +43 °C)
Designed to operate in ambient temperatures:	as low as -15 °C
Door / side walls:	white / white
Exterior dimensions in cm (h / w / d):	82.5 / 167.5 / 70.2



Controls

- Electronic controls in the casing, key electronic
- Thermometer with digital temperature display
- FrostControl
- Alarm in case of malfunction: visual and acoustic
- Door alarm: visual and acoustic

Freezer compartment ********

- Low vibration, low noise, easy-to-clean foam-embedded condenser
- LED lighting
- Temperature rise time: 40 h
- Freezing capacity in 24 hrs: 20 kg
- Defrost drain
- Removable freezer tray as partition wall – can be used as a drip tray
- 2 suspension baskets as standard, 5 retrofittable

Key features

- Recessed handle
- Replaceable door seal
- Concealed hinge with restricted opening

¹ In accordance with Regulation EU 2019/2016 we indicate the total volume to the nearest integer (rounded off) and the volume of the frozen compartments and refrigeration compartments to one place after the decimal point.
You can find the full range of efficiency classes at page 15. According to (EU) 2017/1369 6a.

Wine fridges



WPgbi 5283 Vinidor Selection



Quality in every detail



LightTower

One of the most important – and most neglected – design elements is light. Cleverly used, it can do wonders for setting the right mood, just like it does in our glass door appliances. Two vertical light columns illuminate your wine bottles like the pieces of art they are, every time you open the door, or all the time. The choice is yours – just like the light intensity.



Wall panel in BlackSteel

The ideal backdrop for your wine collection: a rear wall panel in BlackSteel. The striking black stainless steel adds a certain je ne sais quoi to the inside of your wine tempering fridge. However, appearance is just one of its advantages, the back wall also ensures balanced air circulation and perfectly controlled humidity.



Water tray

Ideal humidity, even in dry conditions, thanks to the easily retrofittable water tray. It helps maintain optimal humidity in the appliance by collecting water from inside the appliance or from you filling it as required. This way, your wine collection is kept in the ideal conditions in any environment.



Recessed handle

Functionality meets elegance: the recessed handles of the Vinidor Selection models offer a smooth and comfortable grip – and an unobstructed view of the wine tempering fridge's refined design, which fits even the most sophisticated surroundings.



Integrated door opening mechanism

All doors are meant to be opened, but only some are designed to feel effortless. Whether you need to access your appliance regularly or with minimal effort, the integrated door opening mechanism has your back – while keeping the strain on it to a minimum. As a bonus, the elegant handle adds an eye-catching element to your appliance as well.



FlexFit wooden bars

Even more flexibility for storing wine bottles. The Vinidor Selection models are equipped with FlexFit wooden bars. These can be fitted as accessories for Vinidor models with plastic shelves.



Touch & Swipe display

Maintain the perfect tempering conditions inside your wine appliance, without ever opening the door. The Glass Touch & Swipe display enables you to easily navigate the sleek interface and manage temperature and humidity on the vivid colour display. Even when not in use, the display provides you with real-time temperature updates for each zone.



Electronic door lock

If there is one thing in life you can be sure of, it is your wines. The electronic door lock ensures this – it is unlocked by entering a PIN, preventing unauthorised use. And it is also more efficient, since the convenient unlocking method enables you to open the door more quickly.



Soft telescopic rails

Exploring your wine collection, made even more enjoyable. The thoughtfully designed soft telescopic rails of Vinidor selection fridges ensure a smooth retrieving and retracting of your wine racks, disrupting your wine as little as possible, and bringing it to you with convenience – which leaves you with the simple pleasure of deciding which one suits your taste.



Activated charcoal filter

To ensure that your wine can mature in optimum air quality, all Liebherr wine tempering fridges have an activated charcoal filter that reliably binds odours of all kinds. This means your wine will keep its pure bouquet. To make sure that it stays that way, your Liebherr reminds you every 6 months to change the filter, which you can easily do yourself.



SommelierBoard

Bring elegance to your room, with the SommelierBoard. This refined set presents all of your wine, glasses, decanter, and utensils in a sophisticated manner. Not only does it look amazing, but it also offers practicality with the integrated storage box and dedicated working surface for wine opening and serving.

Model groups

Temperature ranges

+5 °C to +20 °C

+5 °C to +20 °C

+5 °C to +20 °C



2
Zones

3
Zones

With two to three temperature zones that can be set independently from each other to between +5 °C to +20 °C – accurate to the degree – our **multi-temperature wine fridges** offer the most flexibility for any use. That means that red wines, white wines and champagnes can all be stored at the same time and at an ideal temperature in one single appliance with three temperature zones. And these appliances also provide ideal climatic conditions for the long-term storage of wines. With their temperature zones of different sizes and temperature settings that offer complete flexibility, these appliances are perfect for each individual wine collection.

Temperature range

+5 °C to +20 °C



1
Zone

Wine storage fridges recreate the conditions of a wine cellar. A constant temperature is maintained within the entire interior of these appliances. They can be adjusted to between +5 °C and + 20 °C, depending on your requirements. Wine storage fridges are specially designed to hold a large number of bottles for storage and ageing, but they can also keep a larger stock of wine at drinking temperature.



Compact fridges – as specialists in all things cooling, storage and temperature control, Liebherr offers space-saving wonders for any occasion. Enter stage right: our efficient compact appliances for fresh ideas. Compact wine storage fridges provide just the right dimensions for the niche wine collection. Valuable cigars are kept under optimal storage conditions in the humidor.

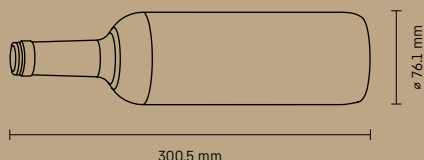



Bordeaux bottle size (0.75 l)

All specifications regarding bottle capacity refer to these dimensions.

Freestanding wine appliances

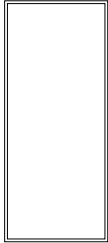
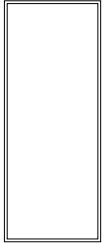
Compact appliances

	← 75 →	← 70 →	← 60 →	← 43 →
Width in cm				
Multi-temperature wine fridges		WPgbi 7483 WPgbi 7473 WPgbi 7472	WPgbi 5283 WPgbi 5273 WPgbi 5272 WPbsi 5252 WSbsi 5252 WPsd 5252 WPbsi 5052 WPsd 4652	
Wine storage fridges	WSbli 7731		WPbli 5231 WSbli 5231 WPbli 5031 WSbli 5031 WPbl 5001 WSbl 5001 WPbl 4601 WSbl 4601 WPbl 4201 WSbl 4201	WKes 653
Humidor				ZKes 453
Outdoor cooler			OKes 1750	



WSbl 5001 GrandCru

	Vinidor	Vinidor Selection
Quality	Constant temperature maintenance	Constant temperature maintenance
	Adjustable temperature range in 2 zones: +5 °C to +20 °C	Adjustable temperature range in 2 or 3 zones: +5 °C to +20 °C
	Constant display of the current temperature in each zone	Permanent display of current temperature
	Triple UV and safety glazing (UVProtect Plus)	Triple UV and safety glazing (UVProtect Plus)
	Vibration-damped bearing (VibrateSafe)	Vibration-damped bearing (VibrateSafe)
	Replaceable door seal	Replaceable door seal
Optimum climate	2 height-adjustable feet	2 height-adjustable feet
	Adjustable humidity with HumiditySelect	Regulated humidity with HumidityControl in the StorageZone
		Actual display of the humidity in the StorageZone
		Water tray
	FreshAir filter in zone separator with replacement reminder	FreshAir filter in each zone separator with replacement reminder
	Temperature setting in 1 °C increments	Temperature setting in 1 °C increments
Comfort and flexibility	Zone separator with plastic bottle shelf, can be upgraded with FlexFit wooden bars (accessory)	Zone separator with FlexFit wooden bars
	Presentation shelf	Stainless steel bottle presenter
	SoftSystem soft stop mechanism	SoftSystem soft stop mechanism
	Height-adjustable wooden racks (additional racks available as accessories)	FlexFit wooden racks with SoftTelescopic self-closing mechanism
	Display: choice of 9 or 12 languages * (DE/EN/FR/ES/IT/NL/CS/PL/PT/BG/RU/ZH-CN)	Display: choice of 12 languages (DE/EN/FR/ES/IT/NL/CS/PL/PT/BG/RU/ZH-CN)
		SommelierBoard *
Design and lifestyle	LED ceiling lighting for each zone	LightTower
	Rear wall panel: SmartSteel	Rear wall panel: BlackSteel
	Touch display (SmartSteel models)	
	Touch & Swipe display (BlackSteel models)	Touch & Swipe display in the glass door
	Presentation light (glass door)	Presentation light
	Slimline aluminium door handle with opening mechanism	Recessed vertical grip
Security	Low noise	Low noise
	InteriorFit	InteriorFit
	TempProtect Plus	TempProtect Plus
	Door, temperature and power failure alarm	Door, temperature and power failure alarm
	Alarm issued both audibly and visually on display, via illumination and push message thanks to SmartDevice **	Alarm issued both audibly and visually on display, via illumination and push message thanks to SmartDevice **
	Display lock	Display lock
Connectivity *	eDoorLock, electronic door lock	
	SmartDevice (SmartDeviceBox included) *	SmartDevice (SmartDeviceBox included)
	Presentation light **	Presentation light **
	Temperature setting in 1-°C increments **	Temperature setting in 1-°C increments **
	Display and control of relevant appliance functions **	Display and control of relevant appliance functions **

Differentiating equipment is **highlighted** in the next higher series.

* depending on the model

** via SmartDevice app

Vinidor

StainlessSteel 60 cm

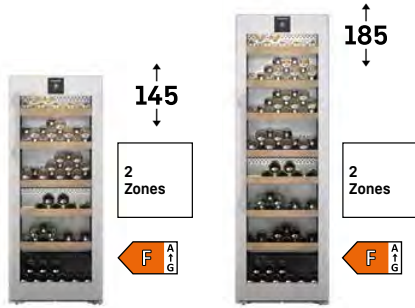

WPsd 4652

WPsd 5252

Max
107

Max
155

Vinidor Selection

GlassBlack 60 cm

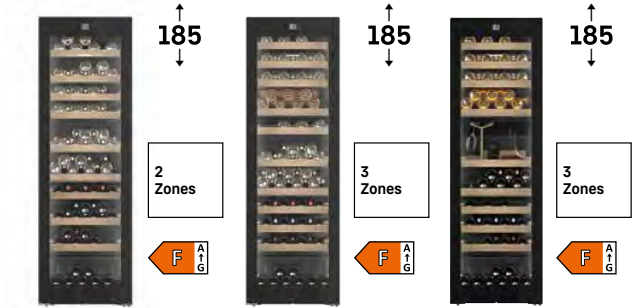

WPgbi 5272

WPgbi 5273

WPgbi 5283

Max
106

Max
104

Max
85

BlackSteel 60 cm

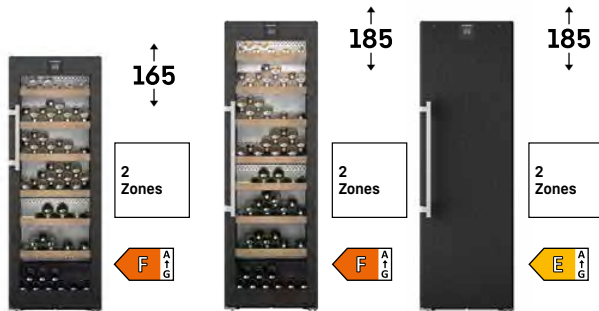

WPbsi 5052

WPbsi 5252

WSbsi 5252

Max
131

Max
155

Max
155

GlassBlack 70 cm

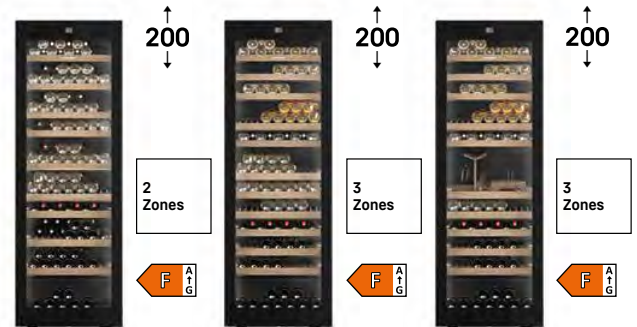

WPgbi 7472

WPgbi 7473

WPgbi 7483

Max
204

Max
182

Max
145

60-cm-wide models: appliance depth 67.5 cm

70-cm-wide models: appliance depth 76.4 cm

Multi-temperature wine fridges



SommelierBoard

Bring elegance to your room, with the SommelierBoard. This refined set presents all of your wine, glasses, decanter, and utensils in a sophisticated manner. Not only does it look amazing, but it also offers practicality with the integrated storage box and dedicated working surface for wine opening and serving.



LightTower

One of the most important – and most neglected – design elements is light. Cleverly used, it can do wonders for setting the right mood, just like it does in our glass door appliances. Two vertical light columns illuminate your wine bottles like the pieces of art they are, every time you open the door, or all the time. The choice is yours – just like the light intensity.



← 70 →

WPgbi 7483

Vinidor Selection

Energy efficiency class:	F ^A _G ²
Energy consumption year / 24 hrs:	144 / 0.394 kWh ²
Max. Bordeaux bottles 0.75 l:	149 ¹
Total volume ³ :	561 l
Noise output / noise class:	35 dB(A) / B, SuperSilent
Climate rating:	SN-ST (from +10 °C to +38 °C)
Door / side walls:	Black insulated glass door / BlackSteel
Exterior dimensions in cm (h / w / d):	201.3 / 69.7 / 76.4 ²

3 Zones	Temp Protect Plus	Humidity Select	Fresh Air	UV Protect Plus	Flex Fit	Sommelier Board	Vibrate Safe	Steel Interior
Light Tower	Soft System	Telescopic Rails	Super Silent	Touch & Swipe Display	eDoor Lock	Smart Device		

Controls

- 2.4" TFT-colour display in-the-door, touch- & swipe
- Digital temperature display for 3 wine zones
- SmartDeviceBox included
- Alarm in case of malfunction: visual and acoustic
- Door alarm: visual and acoustic
- Child lock

Wine compartment

- 3 temperature zones, which can set from +5 °C to +20 °C
- 3 independently controllable zones
- Convection cooling, fresh air supply via FreshAir activated charcoal filter
- Humidity range adjusted between two levels
- LED light panel, both sides permanently on, dimmable
- Beech wood fittings
- 11 shelves, of which 8 set on telescopic rails

Key features

- Vertical recessed handle
- Transport handles, front and at back, transport castors at back
- Height-adjustable feet at front
- Reversible door hinging, right
- Replaceable door seal

¹ These models are only bound for storing wine. Maximum DIN norm bordeaux bottles capacity (0.75 l) as per norm NF H 35-124 (H: 300.5 mm, Ø 76.1 mm)

² To achieve the indicated energy consumption level, the wall spacers provided with the appliance must be used. These increase the appliance depth by approximately 3.5 cm. If the wall spacers are not used, the appliance will remain fully functional, but will have a slightly higher energy consumption level.



Electronic door lock

If there is one thing in life you can be sure of, it is your wines. The electronic door lock ensures this – it is unlocked by entering a PIN, preventing unauthorised use. And it is also more efficient, since the convenient unlocking method enables you to open the door more quickly.



Activated charcoal filter

To ensure that your wine can mature in optimum air quality, all Liebherr wine tempering fridges have an activated charcoal filter that reliably binds odours of all kinds. This means your wine will keep its pure bouquet. To make sure that it stays that way, your Liebherr reminds you every 6 months to change the filter, which you can easily do yourself.

Multi-temperature wine fridges



← 70 →

WPgbi 7473 Vinidor Selection

Energy efficiency class:	F <small>A G</small>
Energy consumption year / 24 hrs:	144 / 0.394 kWh²
Max. Bordeaux bottles 0.75 l:	182¹
Total volume ³ :	561 l
Noise output / noise class:	35 dB(A) / B, SuperSilent
Climate rating:	SN-ST (from +10 °C to +38 °C)
Door / side walls:	Black insulated glass door / BlackSteel
Exterior dimensions in cm (h / w / d):	201.3 / 69.7 / 76.4²

3 Zones	Temp Protect Plus	Humidity Select	Fresh Air	UV Protect Plus	Flex Fit	Vibrate Safe	Steel Interior	Light Tower
Soft System	Telescopic Rails	Super Silent	Touch & Swipe Display	eDoor Lock	Smart Device			

Controls

- 2.4" TFT-colour display in-the-door, touch- & swipe
- Digital temperature display for 3 wine zones
- SmartDeviceBox included
- Alarm in case of malfunction: visual and acoustic
- Door alarm: visual and acoustic
- Child lock

Wine compartment

- 3 temperature zones, which can set from +5 °C to +20 °C
- 3 independently controllable zones
- Convection cooling, fresh air supply via FreshAir activated charcoal filter
- Humidity range adjusted between two levels
- LED light panel, both sides permanently on, dimmable
- Beech wood fittings
- 12 shelves, of which 9 set on telescopic rails

Key features

- Vertical recessed handle
- Transport handles, front and at back, transport castors at back
- Height-adjustable feet at front
- Reversible door hinging, right
- Replaceable door seal

³ In accordance with Regulation EU 2019/2016 we indicate the total volume to the nearest integer (rounded off) and the volume of the frozen compartments and refrigeration compartments to one place after the decimal point. You can find the full range of efficiency classes at page 15. According to (EU) 2017/1369 6a.

Multi-temperature wine fridges



← 70 →

WPgbi 7472

Vinidor Selection

Energy efficiency class:	
Energy consumption year / 24 hrs:	145 / 0.397 kWh ²
Max. Bordeaux bottles 0.75 l:	204 ¹
Total volume ³ :	575 l
Noise output / noise class:	35 dB(A) / B, SuperSilent
Climate rating:	SN-ST (from +10 °C to +38 °C)
Door / side walls:	Black insulated glass door / BlackSteel
Exterior dimensions in cm (h / w / d):	201.3 / 69.7 / 76.4 ²

2 Zones	Temp Protect Plus	Humidity Select	Fresh Air	UV Protect Plus	Flex Fit	Vibrate Safe	Steel Interior	Light Tower
Soft System	Telescopic Rails	Super Silent	Touch & Swipe Display	eDoor Lock	Smart Device			

Controls

- 2.4" TFT-colour display in-the-door, touch- & swipe
- Digital temperature display for both wine zones
- SmartDeviceBox included
- Alarm in case of malfunction: visual and acoustic
- Door alarm: visual and acoustic
- Child lock

Wine compartment

- 2 temperature zones, which can set from +5 °C to +20 °C
- 2 independently controllable zones
- Convection cooling, fresh air supply via FreshAir activated charcoal filter
- Humidity range adjusted between two levels
- LED light panel, both sides permanently on, dimmable
- Beech wood fittings
- 10 shelves, of which 8 set on telescopic rails

Key features

- Vertical recessed handle
- Transport handles, front and at back, transport castors at back
- Height-adjustable feet at front
- Reversible door hinging, right
- Replaceable door seal



← 60 →

WPgbi 5283

Vinidor Selection

Energy efficiency class:	
Energy consumption year / 24 hrs:	126 / 0.345 kWh ²
Max. Bordeaux bottles 0.75 l:	85 ¹
Total volume ³ :	357 l
Noise output / noise class:	35 dB(A) / B, SuperSilent
Climate rating:	SN-ST (from +10 °C to +38 °C)
Door / side walls:	Black insulated glass door / BlackSteel
Exterior dimensions in cm (h / w / d):	185.4 / 59.7 / 67.8 ²

3 Zones	Temp Protect Plus	Humidity Select	Fresh Air	UV Protect Plus	Flex Fit	Sommelier Board	Vibrate Safe	Steel Interior
Light Tower	Soft System	Telescopic Rails	Super Silent	Touch & Swipe Display	eDoor Lock	Smart Device		

Controls

- 2.4" TFT-colour display in-the-door, touch- & swipe
- Digital temperature display for 3 wine zones
- SmartDeviceBox included
- Alarm in case of malfunction: visual and acoustic
- Door alarm: visual and acoustic
- Child lock

Wine compartment

- 3 temperature zones, which can set from +5 °C to +20 °C
- 3 independently controllable zones
- Convection cooling, fresh air supply via FreshAir activated charcoal filter
- Humidity range adjusted between two levels
- LED light panel, both sides permanently on, dimmable
- Beech wood fittings
- 10 shelves, of which 7 set on telescopic rails

Key features

- Vertical recessed handle
- Transport handles, front and at back, transport castors at back
- Height-adjustable feet at front
- Reversible door hinging, right
- Replaceable door seal

¹ These models are only bound for storing wine. Maximum DIN norm bordeaux bottles capacity (0.75 l) as per norm NF H 35-124 (H: 300.5 mm, Ø 76.1 mm)

² To achieve the indicated energy consumption level, the wall spacers provided with the appliance must be used. These increase the appliance depth by approximately 3.5 cm. If the wall spacers are not used, the appliance will remain fully functional, but will have a slightly higher energy consumption level.



← 60 →

WPgbi 5273
Vinidor Selection

Energy efficiency class:	
Energy consumption year / 24 hrs:	126 / 0.345 kWh²
Max. Bordeaux bottles 0.75 l:	104¹
Total volume ³ :	357 l
Noise output / noise class:	35 dB(A) / B, SuperSilent
Climate rating:	SN-ST (from +10 °C to +38 °C)
Door / side walls:	Black insulated glass door / BlackSteel
Exterior dimensions in cm (h / w / d):	185.4 / 59.7 / 67.8²

3 Zones	Temp Protect Plus	Humidity Select	Fresh Air	UV Protect Plus	Flex Fit	Vibrate Safe	Steel Interior	Light Tower
Soft System	Telescopic Rails	Super Silent	Touch & Swipe Display	eDoor Lock	Smart Device			

Controls

- 2.4" TFT-colour display in-the-door, touch- & swipe
- Digital temperature display for 3 wine zones
- SmartDeviceBox included
- Alarm in case of malfunction: visual and acoustic
- Door alarm: visual and acoustic
- Child lock

Wine compartment

- 3 temperature zones, which can set from +5 °C to +20 °C
- 3 independently controllable zones
- Convection cooling, fresh air supply via FreshAir activated charcoal filter
- Humidity range adjusted between two levels
- LED light panel, both sides permanently on, dimmable
- Beech wood fittings
- 11 shelves, of which 8 set on telescopic rails

Key features

- Vertical recessed handle
- Transport handles, front and at back, transport castors at back
- Height-adjustable feet at front
- Reversible door hinging, right
- Replaceable door seal



← 60 →

WPgbi 5272
Vinidor Selection

Energy efficiency class:	
Energy consumption year / 24 hrs:	127 / 0.347 kWh²
Max. Bordeaux bottles 0.75 l:	106¹
Total volume ³ :	367 l
Noise output / noise class:	35 dB(A) / B, SuperSilent
Climate rating:	SN-ST (from +10 °C to +38 °C)
Door / side walls:	Black insulated glass door / BlackSteel
Exterior dimensions in cm (h / w / d):	185.4 / 59.7 / 67.8²

2 Zones	Temp Protect Plus	Humidity Select	Fresh Air	UV Protect Plus	Flex Fit	Vibrate Safe	Steel Interior	Light Tower
Soft System	Telescopic Rails	Super Silent	Touch & Swipe Display	eDoor Lock	Smart Device			

Controls

- 2.4" TFT-colour display in-the-door, touch- & swipe
- Digital temperature display for both wine zones
- SmartDeviceBox included
- Alarm in case of malfunction: visual and acoustic
- Door alarm: visual and acoustic
- Child lock

Wine compartment

- 2 temperature zones, which can set from +5 °C to +20 °C
- 2 independently controllable zones
- Convection cooling, fresh air supply via FreshAir activated charcoal filter
- Humidity range adjusted between two levels
- LED light panel, both sides permanently on, dimmable
- Beech wood fittings
- 10 shelves, of which 8 set on telescopic rails

Key features

- Vertical recessed handle
- Transport handles, front and at back, transport castors at back
- Height-adjustable feet at front
- Reversible door hinging, right
- Replaceable door seal

³ In accordance with Regulation EU 2019/2016 we indicate the total volume to the nearest integer (rounded off) and the volume of the frozen compartments and refrigeration compartments to one place after the decimal point. You can find the full range of efficiency classes at page 15. According to (EU) 2017/1369 6a.

Multi-temperature wine fridges



Touch & Swipe display

Maintain the perfect tempering conditions inside your wine appliance, without ever opening the door. The Glass Touch & Swipe display enables you to easily navigate the sleek interface and manage temperature and humidity on the vivid colour display. Even when not in use, the display provides you with real-time temperature updates for each zone.



Integrated door opening mechanism

All doors are meant to be opened, but only some are designed to feel effortless. Whether you need to access your appliance regularly or with minimal effort, the integrated door opening mechanism has your back – while keeping the strain on it to a minimum. As a bonus, the elegant handle adds an eye-catching element to your appliance as well.



← 60 →

WPbsi 5252

Vinidor

Energy efficiency class:	
Energy consumption year / 24 hrs:	127 / 0.347 kWh ²
Max. Bordeaux bottles 0.75 l:	155 ¹
Total volume ³ :	367 l
Noise output / noise class:	37 dB(A) / C
Climate rating:	SN-ST (from +10 °C to +38 °C)
Door / side walls:	Insulating glass door with frame in BlackSteel / BlackSteel
Exterior dimensions in cm (h / w / d):	185.4 / 59.7 / 67.5 ²

2 Zones	Temp Protect Plus	Humidity Select	Fresh Air	UV Protect Plus	Vibrate Safe	Steel Interior	LED	Soft System
Touch & Swipe Display	Presentation Board	Smart Device						

Controls

- 2.4" TFT-colour display in-the-door, touch- & swipe
- Digital temperature display for both wine zones
- SmartDeviceBox included
- Alarm in case of malfunction: visual and acoustic
- Door alarm: visual and acoustic
- Child lock

Wine compartment

- 2 temperature zones, which can set from +5°C to +20°C
- 2 independently controllable zones
- Convection cooling, fresh air supply via FreshAir activated charcoal filter
- Humidity range adjusted between two levels
- LED zone lighting permanently on, dimmable
- Adjustable beech wood shelves
- 8 shelves, of which 1 is a presentation shelf

Key features

- Slimline handle with integrated opening mechanism
- Transport handles, front and at back, transport castors at back
- Height-adjustable feet at front
- Reversible door hinging, right
- Replaceable door seal

¹ These models are only bound for storing wine. Maximum DIN norm bordeaux bottles capacity (0.75 l) as per norm NF H 35-124 (H: 300.5 mm, Ø 76.1 mm)

² To achieve the indicated energy consumption level, the wall spacers provided with the appliance must be used. These increase the appliance depth by approximately 3.5 cm. If the wall spacers are not used, the appliance will remain fully functional, but will have a slightly higher energy consumption level.



← 60 →

WSbsi 5252

Vinidor

Energy efficiency class:	
Energy consumption year / 24 hrs:	100 / 0.274 kWh ²
Max. Bordeaux bottles 0.75 l:	155 ¹
Total volume ³ :	349 l
Noise output / noise class:	37 dB(A) / C
Climate rating:	SN-T (from +10 °C to +43 °C)
Door / side walls:	Full door, BlackSteel / BlackSteel
Exterior dimensions in cm (h / w / d):	185.4 / 59.7 / 67.5 ²

2 Zones	Temp Protect Plus	Humidity Select	Fresh Air	Vibrate Safe	Steel Interior	LED	Soft System	Touch & Swipe Display
Presentation Board	Smart Device							

Controls

- 2.4" TFT-colour display in-the-door, touch- & swipe
- Digital temperature display for both wine zones
- SmartDeviceBox included
- Alarm in case of malfunction: visual and acoustic
- Door alarm: visual and acoustic
- Child lock

Wine compartment

- 2 temperature zones, which can set from +5 °C to +20 °C
- 2 independently controllable zones
- Convection cooling, fresh air supply via FreshAir activated charcoal filter
- Humidity range adjusted between two levels
- LED zone lighting
- Adjustable beech wood shelves
- 8 shelves, of which 1 is a presentation shelf

Key features

- Slimline handle with integrated opening mechanism
- Transport handles, front and at back, transport castors at back
- Height-adjustable feet at front
- Reversible door hinging, right
- Replaceable door seal



← 60 →

WPsd 5252

Vinidor

Energy efficiency class:	
Energy consumption year / 24 hrs:	127 / 0.347 kWh ²
Max. Bordeaux bottles 0.75 l:	155 ¹
Total volume ³ :	367 l
Noise output / noise class:	37 dB(A) / C
Climate rating:	SN-ST (from +10 °C to +38 °C)
Door / side walls:	Glass door with stainless steel frame and SmartSteel / silver
Exterior dimensions in cm (h / w / d):	185.4 / 59.7 / 67.5 ²

2 Zones	Temp Protect Plus	Humidity Select	Fresh Air	UV Protect Plus	Vibrate Safe	Steel Interior	LED	Touch Display
Smart Device Ready								

Controls

- LC monochrome display in the door, touch electronic
- Digital temperature display for both wine zones
- SmartDeviceBox: optional accessory
- Alarm in case of malfunction: visual and acoustic
- Door alarm: visual and acoustic
- Child lock

Wine compartment

- 2 temperature zones, which can set from +5 °C to +20 °C
- 2 independently controllable zones
- Convection cooling, fresh air supply via FreshAir activated charcoal filter
- Humidity range adjusted between two levels
- LED zone lighting permanently on, dimmable
- Adjustable beech wood shelves
- 8 shelves

Key features

- Slimline handle with integrated opening mechanism
- Transport handles, front and at back, transport castors at back
- Height-adjustable feet at front
- Reversible door hinging, right
- Replaceable door seal

³ In accordance with Regulation EU 2019/2016 we indicate the total volume to the nearest integer (rounded off) and the volume of the frozen compartments and refrigeration compartments to one place after the decimal point. You can find the full range of efficiency classes at page 15. According to (EU) 2017/1369 6a.

Multi-temperature wine fridges



TempProtect Plus

Double protection. With TempProtect Plus, our wine storage cabinets constantly measure the temperature with two sensors. This gives you double the assurance that your wines are protected from temperature fluctuations. This is because you are alerted as soon as one of the sensors detects a critical change in temperature, allowing you to take action quickly.



Integrated door opening mechanism

All doors are meant to be opened, but only some are designed to feel effortless. Whether you need to access your appliance regularly or with minimal effort, the integrated door opening mechanism has your back – while keeping the strain on it to a minimum. As a bonus, the elegant handle adds an eye-catching element to your appliance as well.



← 60 →

WPbsi 5052

Vinidor

Energy efficiency class:	F ^A / _G ²
Energy consumption year / 24 hrs:	123 / 0.337 kWh ²
Max. Bordeaux bottles 0.75 l:	131 ¹
Total volume ³ :	319 l
Noise output / noise class:	37 dB(A) / C
Climate rating:	SN-ST (from +10 °C to +38 °C)
Door / side walls:	Insulating glass door with frame in BlackSteel / BlackSteel
Exterior dimensions in cm (h / w / d):	165.4 / 59.7 / 67.5 ²

2 Zones	Temp Protect Plus	Humidity Select	Fresh Air	UV Protect Plus	Vibrate Safe	Steel Interior	LED	Soft System
Touch & Swipe Display	Presentation Board	Smart Device						

Controls

- 2.4" TFT-colour display in-the-door, touch- & swipe
- Digital temperature display for both wine zones
- SmartDeviceBox included
- Alarm in case of malfunction: visual and acoustic
- Door alarm: visual and acoustic
- Child lock

Wine compartment

- 2 temperature zones, which can set from +5 °C to +20 °C
- 2 independently controllable zones
- Convection cooling, fresh air supply via FreshAir activated charcoal filter
- Humidity range adjusted between two levels
- LED zone lighting permanently on, dimmable
- Adjustable beech wood shelves
- 7 shelves, of which 1 is a presentation shelf

Key features

- Slimline handle with integrated opening mechanism
- Transport handles, front and at back, transport castors at back
- Height-adjustable feet at front
- Reversible door hinging, right
- Replaceable door seal

¹ These models are only bound for storing wine. Maximum DIN norm bordeaux bottles capacity (0.75 l) as per norm NF H 35-124 (H: 300.5 mm, Ø 76.1 mm)

² To achieve the indicated energy consumption level, the wall spacers provided with the appliance must be used. These increase the appliance depth by approximately 3.5 cm. If the wall spacers are not used, the appliance will remain fully functional, but will have a slightly higher energy consumption level.



UVProtect Plus

Triple protection. For long-term storage, the wine storage cabinets with glass door offer unprecedented protection from UV radiation: three protective layers consisting of tinted glass and a double layer of vacuum-deposited metal. Known as Low-E coating, it provides highly efficient protection for your wine against harmful solar radiation.



Activated charcoal filter

To ensure that your wine can mature in optimum air quality, all Liebherr wine tempering fridges have an activated charcoal filter that reliably binds odours of all kinds. This means your wine will keep its pure bouquet. To make sure that it stays that way, your Liebherr reminds you every 6 months to change the filter, which you can easily do yourself.

³ In accordance with Regulation EU 2019/2016 we indicate the total volume to the nearest integer (rounded off) and the volume of the frozen compartments and refrigeration compartments to one place after the decimal point. You can find the full range of efficiency classes at page 15. According to (EU) 2017/1369 6a.

Multi-temperature wine fridges



← 60 →

WPsd 4652

Vinidor

Energy efficiency class:	F ^A / _G ²
Energy consumption year / 24 hrs:	118 / 0.323 kWh ²
Max. Bordeaux bottles 0.75 l:	107 ¹
Total volume ³ :	272 l
Noise output / noise class:	38 dB(A) / C
Climate rating:	SN-ST (from +10 °C to +38 °C)
Door / side walls:	Glass door with stainless steel frame and SmartSteel / silver
Exterior dimensions in cm (h / w / d):	145.4 / 59.7 / 67.5 ²

2 Zones	Temp Protect Plus	Humidity Select	Fresh Air	UV Protect Plus	Vibrate Safe	Steel Interior	LED	Touch Display
Smart Device Ready								

Controls

- LC monochrome display in the door, touch electronic
- Digital temperature display for both wine zones
- SmartDeviceBox: optional accessory
- Alarm in case of malfunction: visual and acoustic
- Door alarm: visual and acoustic
- Child lock

Wine compartment

- 2 temperature zones, which can set from +5 °C to +20 °C
- 2 independently controllable zones
- Convection cooling, fresh air supply via FreshAir activated charcoal filter
- Humidity range adjusted between two levels
- LED zone lighting permanently on, dimmable
- Adjustable beech wood shelves
- 6 shelves

Key features

- Slimline handle with integrated opening mechanism
- Transport handles, front and at back, transport castors at back
- Height-adjustable feet at front
- Reversible door hinging, right
- Replaceable door seal

	GrandCru	GrandCru Selection
Quality	Constant temperature maintenance Adjustable temperature range in one zone: +5 °C to +20 °C Permanent display of current temperature Triple UV and safety glazing / UVProtect Plus Low-vibration storage / VibrateSafe Neck-to-neck storage for maximum bottle capacity Replaceable door seal 2 height-adjustable feet	Constant temperature maintenance Adjustable temperature range in one zone: +5 °C to +20 °C Permanent display of current temperature Triple UV and safety glazing / UVProtect Plus Low-vibration storage / VibrateSafe Neck-to-neck storage for maximum bottle capacity Replaceable door seal 2 height-adjustable feet
Feel good climate	Adjustable humidity with HumiditySelect 1 FreshAir filter with replacement reminder Temperature setting in 1°C steps	Controllable humidity with HumidityControl Current humidity display 1 FreshAir filter with replacement reminder Temperature setting in 1°C steps
Convenience and flexibility	EasyFill loading aid SelfClosing Door Wooden pull-out shelf, height-adjustable Display: select from 9 languages (DE/EN/FR/ES/IT/NL/CS/PL/PT)	EasyFill loading aid SelfClosing Door Wooden pull-out shelf, height-adjustable Display: select from 9 languages (DE/EN/FR/ES/IT/NL/CS/PL/PT)
Design and lifestyle	LED ceiling lighting Rear wall panel: metal, graphite grey Touch display Presentation light (glass door) Handle: black Low noise	LED ceiling lighting (solid door), LightColumn (glass door) Rear wall panel: stainless steel Touch display Presentation light (glass door) Handle: brushed aluminium Low noise
Safety	TempProtect Plus Door, temperature and power failure alarm Alarm issued both audibly and visually on display, via illumination and push message thanks to SmartDevice* DisplayLock Mechanical lock, retrofittable	TempProtect Plus Door, temperature and power failure alarm Alarm issued both audibly and visually on display, via illumination and push message thanks to SmartDevice* DisplayLock Mechanical lock, integrated
Connectivity*	SmartDevice ready Presentation light* Temperature setting in 1°C steps* Display and control of relevant appliance functions*	SmartDevice (SmartDeviceBox included) Presentation light* Temperature setting in 1°C steps* Display and control of relevant appliance functions*

Differentiating equipment is **highlighted** in the next higher series.

* via SmartDevice app

GrandCru

WPbl 4201 **WSbl 4201**

125**
← 60 →
max. 142

GrandCru Selection

WPbli 5031 **WSbli 5031**

165**
← 60 →
max. 196

WPbl 4601 **WSbl 4601**

145**
← 60 →
max. 166

WPbli 5231 **WSbli 5231**

185**
← 60 →
max. 229

WPbl 5001 **WSbl 5001**

165**
← 60 →
max. 196

WSbli 7731

201**
← 75 →
max. 324

** + 3.4 cm door hinge



WSbli 7731 GrandCru Selection



← 75 →

WSbli 7731

GrandCru Selection

Energy efficiency class:	
Energy consumption year / 24 hrs:	102 / 0.279 kWh ²
Max. Bordeaux bottles 0.75 l:	324 ¹
Total volume ³ :	628 l
Noise output / noise class:	38 dB(A) / C
Climate rating:	SN-T (from +10 °C to +43 °C)
Door / side walls:	Full door, black / black
Exterior dimensions in cm (h / w / d):	204.4 / 74.7 / 76.3 ²

1 Zone	Temp Protect Plus	Humidity Control	Fresh Air	Vibrate Safe	Steel Interior	LED	Touch Display	Door Lock
Self Closing Door	Easy Fill	Smart Device						

Controls

- LC monochrome display in the door, touch electronic
- Digital temperature display
- SmartDeviceBox included
- Alarm in case of malfunction: visual and acoustic
- Door alarm: visual and acoustic
- Child lock

Wine compartment

- 1 temperature zone, which can set from +5 °C to +20 °C
- Humidity regulation adjustable between 50% to 80% RH*
- Convection cooling, fresh air supply via FreshAir activated charcoal filter
- Humidity regulation via adjustable fan
- LED ceiling lighting
- Adjustable beech wood shelves
- 7 shelves

Key features

- Aluminium handle
- Transport handles at back, transport castors at back
- Height-adjustable feet at front
- Reversible door hinging, right
- Replaceable door seal

¹ These models are only bound for storing wine. Maximum DIN norm bordeaux bottles capacity (0.75 l) as per norm NF H 35-124 (H: 300.5 mm, Ø 76.1 mm)

² To achieve the indicated energy consumption level, the wall spacers provided with the appliance must be used. These increase the appliance depth by approximately 3.5 cm. If the wall spacers are not used, the appliance will remain fully functional, but will have a slightly higher energy consumption level.



← 60 →

WPbli 5231
GrandCru Selection



← 60 →

WSbli 5231
GrandCru Selection

Energy efficiency class:	F ^A / _G ²
Energy consumption year / 24 hrs:	115 / 0.315 kWh ²
Max. Bordeaux bottles 0.75 l:	229 ¹
Total volume ³ :	442 l
Noise output / noise class:	38 dB(A) / C
Climate rating:	SN-ST (from +10 °C to +38 °C)
Door / side walls:	Glass door, frame black / black
Exterior dimensions in cm (h / w / d):	188.4 / 59.7 / 76.3 ²

1 Zone	Temp Protect Plus	Humidity Control	Fresh Air	UV Protect Plus	Vibrate Safe	Steel Interior	Light Column	Presentation Light
Touch Display	Door Lock	Self Closing Door	Easy Fill	Smart Device				

Controls

- LC monochrome display in the door, touch electronic
- Digital temperature display
- SmartDeviceBox included
- Alarm in case of malfunction: visual and acoustic
- Door alarm: visual and acoustic
- Child lock

Wine compartment

- 1 temperature zone, which can set from +5 °C to +20 °C
- Humidity regulation adjustable between 50% to 80% RH*
- Convection cooling, fresh air supply via FreshAir activated charcoal filter
- Humidity regulation via adjustable fan
- LED light one-sided permanently on, dimmable
- Adjustable beech wood shelves
- 6 shelves

Key features

- Aluminium handle
- Transport handles at back, transport castors at back
- Height-adjustable feet at front
- Reversible door hinging, right
- Replaceable door seal

Energy efficiency class:	E ^A / _G ²
Energy consumption year / 24 hrs:	96 / 0.263 kWh ²
Max. Bordeaux bottles 0.75 l:	229 ¹
Total volume ³ :	433 l
Noise output / noise class:	38 dB(A) / C
Climate rating:	SN-T (from +10 °C to +43 °C)
Door / side walls:	Full door, black / black
Exterior dimensions in cm (h / w / d):	188.4 / 59.7 / 76.3 ²

1 Zone	Temp Protect Plus	Humidity Control	Fresh Air	Vibrate Safe	Steel Interior	LED	Touch Display	Door Lock
Self Closing Door	Easy Fill	Smart Device						

Controls

- LC monochrome display in the door, touch electronic
- Digital temperature display
- SmartDeviceBox included
- Alarm in case of malfunction: visual and acoustic
- Door alarm: visual and acoustic
- Child lock

Wine compartment

- 1 temperature zone, which can set from +5 °C to +20 °C
- Humidity regulation adjustable between 50% to 80% RH*
- Convection cooling, fresh air supply via FreshAir activated charcoal filter
- Humidity regulation via adjustable fan
- LED ceiling lighting
- Adjustable beech wood shelves
- 6 shelves

Key features

- Aluminium handle
- Transport handles at back, transport castors at back
- Height-adjustable feet at front
- Reversible door hinging, right
- Replaceable door seal

* At temperatures in home environments. In very dry or cold environments such as home cellars, we recommend supporting the system with the tailor-made water box from our range of accessories.

³ In accordance with Regulation EU 2019/2016 we indicate the total volume to the nearest integer (rounded off) and the volume of the frozen compartments and refrigeration compartments to one place after the decimal point. You can find the full range of efficiency classes at page 15. According to (EU) 2017/1369 6a.

Wine storage fridges



← 60 →

WPbli 5031
GrandCru Selection

Energy efficiency class:	
Energy consumption year / 24 hrs:	111 / 0.304 kWh ²
Max. Bordeaux bottles 0.75 l:	196 ¹
Total volume ³ :	385 l
Noise output / noise class:	38 dB(A) / C
Climate rating:	SN-ST (from +10 °C to +38 °C)
Door / side walls:	Glass door, frame black / black
Exterior dimensions in cm (h / w / d):	168.4 / 59.7 / 76.3 ²

1 Zone	Temp Protect Plus	Humidity Control	Fresh Air	UV Protect Plus	Vibrate Safe	Steel Interior	Light Column	Presentation Light
Touch Display	Door Lock	Self Closing Door	Easy Fill	Smart Device				

Controls

- LC monochrome display in the door, touch electronic
- Digital temperature display
- SmartDeviceBox included
- Alarm in case of malfunction: visual and acoustic
- Door alarm: visual and acoustic
- Child lock

Wine compartment

- 1 temperature zone, which can set from +5 °C to +20 °C
- Humidity regulation adjustable between 50% to 80% RH*
- Convection cooling, fresh air supply via FreshAir activated charcoal filter
- Humidity regulation via adjustable fan
- LED light one-sided permanently on, dimmable
- Adjustable beech wood shelves
- 5 shelves

Key features

- Aluminium handle
- Transport handles at back, transport castors at back
- Height-adjustable feet at front
- Reversible door hinging, right
- Replaceable door seal



← 60 →

WSbli 5031
GrandCru Selection

Energy efficiency class:	
Energy consumption year / 24 hrs:	97 / 0.265 kWh ²
Max. Bordeaux bottles 0.75 l:	196 ¹
Total volume ³ :	378 l
Noise output / noise class:	38 dB(A) / C
Climate rating:	SN-T (from +10 °C to +43 °C)
Door / side walls:	Full door, black / black
Exterior dimensions in cm (h / w / d):	168.4 / 59.7 / 76.3 ²

1 Zone	Temp Protect Plus	Humidity Control	Fresh Air	Vibrate Safe	Steel Interior	LED	Touch Display	Door Lock
Self Closing Door	Easy Fill	Smart Device						

Controls

- LC monochrome display in the door, touch electronic
- Digital temperature display
- SmartDeviceBox included
- Alarm in case of malfunction: visual and acoustic
- Door alarm: visual and acoustic
- Child lock

Wine compartment

- 1 temperature zone, which can set from +5 °C to +20 °C
- Humidity regulation adjustable between 50% to 80% RH*
- Convection cooling, fresh air supply via FreshAir activated charcoal filter
- Humidity regulation via adjustable fan
- LED ceiling lighting
- Adjustable beech wood shelves
- 5 shelves

Key features

- Aluminium handle
- Transport handles at back, transport castors at back
- Height-adjustable feet at front
- Reversible door hinging, right
- Replaceable door seal

* At temperatures in home environments. In very dry or cold environments such as home cellars, we recommend supporting the system with the tailor-made water box from our range of accessories.

¹ These models are only bound for storing wine. Maximum DIN norm bordeaux bottles capacity (0.75 l) as per norm NF H 35-124 (H: 300.5 mm, Ø 76.1 mm)
² To achieve the indicated energy consumption level, the wall spacers provided with the appliance must be used. These increase the appliance depth by approximately 3.5 cm. If the wall spacers are not used, the appliance will remain fully functional, but will have a slightly higher energy consumption level.



← 60 →

WPbl 5001

GrandCru



← 60 →

WSbl 5001

GrandCru

Energy efficiency class:	
Energy consumption year / 24 hrs:	113 / 0.309 kWh ²
Max. Bordeaux bottles 0.75 l:	196 ¹
Total volume ³ :	385 l
Noise output / noise class:	38 dB(A) / C
Climate rating:	SN-ST (from +10 °C to +38 °C)
Door / side walls:	Glass door, frame black / black
Exterior dimensions in cm (h / w / d):	168.4 / 59.7 / 76.3 ²

1 Zone	Temp Protect Plus	Humidity Select	Fresh Air	UV Protect Plus	Vibrate Safe	LED	Touch Display	Door Lock
Self Closing Door	Easy Fill	Smart Device Ready						

Controls

- LC monochrome display in the door, touch electronic
- Digital temperature display
- SmartDeviceBox: optional accessory
- Alarm in case of malfunction: visual and acoustic
- Door alarm: visual and acoustic
- Child lock

Wine compartment

- 1 temperature zone, which can set from +5 °C to +20 °C
- Convection cooling, fresh air supply via FreshAir activated charcoal filter
- Humidity range adjusted between two levels
- LED ceiling lighting permanently on, dimmable
- Adjustable beech wood shelves
- 5 shelves

Key features

- Slimline handle, black
- Transport handles at back, transport castors at back
- Height-adjustable feet at front
- Reversible door hinging, right
- Replaceable door seal

Energy efficiency class:	
Energy consumption year / 24 hrs:	97 / 0.265 kWh ²
Max. Bordeaux bottles 0.75 l:	196 ¹
Total volume ³ :	378 l
Noise output / noise class:	38 dB(A) / C
Climate rating:	SN-T (from +10 °C to +43 °C)
Door / side walls:	Full door, black / black
Exterior dimensions in cm (h / w / d):	168.4 / 59.7 / 76.3 ²

1 Zone	Temp Protect Plus	Humidity Select	Fresh Air	Vibrate Safe	LED	Touch Display	Door Lock	Self Closing Door
Easy Fill	Smart Device Ready							

Controls

- LC monochrome display in the door, touch electronic
- Digital temperature display
- SmartDeviceBox: optional accessory
- Alarm in case of malfunction: visual and acoustic
- Door alarm: visual and acoustic
- Child lock

Wine compartment

- 1 temperature zone, which can set from +5 °C to +20 °C
- Convection cooling, fresh air supply via FreshAir activated charcoal filter
- Humidity range adjusted between two levels
- LED ceiling lighting
- Adjustable beech wood shelves
- 5 shelves

Key features

- Slimline handle, black
- Transport handles at back, transport castors at back
- Height-adjustable feet at front
- Reversible door hinging, right
- Replaceable door seal

³ In accordance with Regulation EU 2019/2016 we indicate the total volume to the nearest integer (rounded off) and the volume of the frozen compartments and refrigeration compartments to one place after the decimal point. You can find the full range of efficiency classes at page 15. According to (EU) 2017/1369 6a.

Wine storage fridges



← 60 →

WPbl 4601

GrandCru

Energy efficiency class:	
Energy consumption year / 24 hrs:	111 / 0.304 kWh ²
Max. Bordeaux bottles 0.75 l:	166 ¹
Total volume ³ :	328 l
Noise output / noise class:	38 dB(A) / C
Climate rating:	SN-ST (from +10 °C to +38 °C)
Door / side walls:	Glass door, frame black / black
Exterior dimensions in cm (h / w / d):	148.4 / 59.7 / 76.3 ²

1 Zone	Temp Protect Plus	Humidity Select	Fresh Air	UV Protect Plus	Vibrate Safe	LED	Touch Display	Door Lock
Self Closing Door	Easy Fill	Smart Device Ready						

Controls

- LC monochrome display in the door, touch electronic
- Digital temperature display
- SmartDeviceBox: optional accessory
- Alarm in case of malfunction: visual and acoustic
- Door alarm: visual and acoustic
- Child lock

Wine compartment

- 1 temperature zone, which can set from +5 °C to +20 °C
- Convection cooling, fresh air supply via FreshAir activated charcoal filter
- Humidity range adjusted between two levels
- LED ceiling lighting permanently on, dimmable
- Adjustable beech wood shelves
- 5 shelves

Key features

- Slimline handle, black
- Transport handles at back, transport castors at back
- Height-adjustable feet at front
- Reversible door hinging, right
- Replaceable door seal



← 60 →

WSbl 4601

GrandCru

Energy efficiency class:	
Energy consumption year / 24 hrs:	84 / 0.230 kWh ²
Max. Bordeaux bottles 0.75 l:	166 ¹
Total volume ³ :	322 l
Noise output / noise class:	38 dB(A) / C
Climate rating:	SN-T (from +10 °C to +43 °C)
Door / side walls:	Full door, black / black
Exterior dimensions in cm (h / w / d):	148.4 / 59.7 / 76.3 ²

1 Zone	Temp Protect Plus	Humidity Select	Fresh Air	Vibrate Safe	LED	Touch Display	Door Lock	Self Closing Door
Easy Fill	Smart Device Ready							

Controls

- LC monochrome display in the door, touch electronic
- Digital temperature display
- SmartDeviceBox: optional accessory
- Alarm in case of malfunction: visual and acoustic
- Door alarm: visual and acoustic
- Child lock

Wine compartment

- 1 temperature zone, which can set from +5 °C to +20 °C
- Convection cooling, fresh air supply via FreshAir activated charcoal filter
- Humidity range adjusted between two levels
- LED ceiling lighting
- Adjustable beech wood shelves
- 5 shelves

Key features

- Slimline handle, black
- Transport handles at back, transport castors at back
- Height-adjustable feet at front
- Reversible door hinging, right
- Replaceable door seal

¹ These models are only bound for storing wine. Maximum DIN norm bordeaux bottles capacity (0.75 l) as per norm NF H 35-124 (H: 300.5 mm, Ø 76.1 mm)
² To achieve the indicated energy consumption level, the wall spacers provided with the appliance must be used. These increase the appliance depth by approximately 3.5 cm. If the wall spacers are not used, the appliance will remain fully functional, but will have a slightly higher energy consumption level.



← 60 →

WPbl 4201

GrandCru



← 60 →

WSbl 4201

GrandCru

Energy efficiency class:	
Energy consumption year / 24 hrs:	95 / 0.260 kWh ²
Max. Bordeaux bottles 0.75 l:	141 ¹
Total volume ³ :	272 l
Noise output / noise class:	38 dB(A) / C
Climate rating:	SN-ST (from +10 °C to +38 °C)
Door / side walls:	Glass door, frame black / black
Exterior dimensions in cm (h / w / d):	128.4 / 59.7 / 76.3 ²

1 Zone	Temp Protect Plus	Humidity Select	Fresh Air	UV Protect Plus	Vibrate Safe	LED	Touch Display	Door Lock
Self Closing Door	Easy Fill	Smart Device Ready						

Controls

- LC monochrome display in the door, touch electronic
- Digital temperature display
- SmartDeviceBox: optional accessory
- Alarm in case of malfunction: visual and acoustic
- Door alarm: visual and acoustic
- Child lock

Wine compartment

- 1 temperature zone, which can set from +5 °C to +20 °C
- Convection cooling, fresh air supply via FreshAir activated charcoal filter
- Humidity range adjusted between two levels
- LED ceiling lighting permanently on, dimmable
- Adjustable beech wood shelves
- 4 shelves

Key features

- Slimline handle, black
- Transport handles at back, transport castors at back
- Height-adjustable feet at front
- Reversible door hinging, right
- Replaceable door seal

Energy efficiency class:	
Energy consumption year / 24 hrs:	76 / 0.208 kWh ²
Max. Bordeaux bottles 0.75 l:	141 ¹
Total volume ³ :	267 l
Noise output / noise class:	38 dB(A) / C
Climate rating:	SN-T (from +10 °C to +43 °C)
Door / side walls:	Full door, black / black
Exterior dimensions in cm (h / w / d):	128.4 / 59.7 / 76.3 ²

1 Zone	Temp Protect Plus	Humidity Select	Fresh Air	Vibrate Safe	LED	Touch Display	Door Lock	Self Closing Door
Easy Fill	Smart Device Ready							

Controls

- LC monochrome display in the door, touch electronic
- Digital temperature display
- SmartDeviceBox: optional accessory
- Alarm in case of malfunction: visual and acoustic
- Door alarm: visual and acoustic
- Child lock

Wine compartment

- 1 temperature zone, which can set from +5 °C to +20 °C
- Convection cooling, fresh air supply via FreshAir activated charcoal filter
- Humidity range adjusted between two levels
- LED ceiling lighting
- Adjustable beech wood shelves
- 4 shelves

Key features

- Slimline handle, black
- Transport handles at back, transport castors at back
- Height-adjustable feet at front
- Reversible door hinging, right
- Replaceable door seal

³ In accordance with Regulation EU 2019/2016 we indicate the total volume to the nearest integer (rounded off) and the volume of the frozen compartments and refrigeration compartments to one place after the decimal point. You can find the full range of efficiency classes at page 15. According to (EU) 2017/1369 6a.

Outdoor cooler



Outdoor

Outdoor kitchens with refrigerators – whether freestanding or built-in – also provide convenience and perfect storage outdoors. The Outdoor Cooler is ideally suited to outdoor use thanks to its rust- and weatherproof materials, robust construction and high-quality components as well as its automatic shut-down function and integrated lock.



Flexible and ergonomic interior layout

With bottles stored at the bottom, the two storage racks are ideal for smaller packages. The glass shelf on telescopic rails provides an overview of foodstuffs stored at the back. Depending on the size, containers can also be stored on two height-adjustable glass shelves. And a separable glass shelf means that larger and open bottles can easily be stored upright.



← 60 →

OKes 1750

Energy efficiency class ¹ :	B <small>A G</small>
Energy consumption year / 24 hrs ² :	177 / 0.484 kWh
Total volume ³ :	109 l
Door / side walls:	Stainless steel / stainless steel
Exterior dimensions in cm (h / w / d):	81.8 / 59.8 / 57.7



Controls

- LCD display in the interior
- Alarm in case of malfunction: visual and acoustic
- Door alarm: visual and acoustic
- Child lock

Outdoor Cooler

- LED lighting
- 1 temperature zone, which can set from +2°C to +14°C
- Safety shut-down
- Ambient temperature range: +2°C to +35°C

Key features

- Can be installed underneath counters (ventilation via the base)
- Stainless steel slimline door handle
- Height-adjustable feet at front and back
- Reversible door hinging, right
- Concealed hinge with restricted opening
- Lock
- Splash-proof class: IPX-4

¹ As per EU Regulation 2019/2018.

² Measured as per EN 16902:2016.

³ In accordance with Regulation EU 2019/2016 we indicate the total volume to the nearest integer (rounded off) and the volume of the frozen compartments and refrigeration compartments to one place after the decimal point.

You can find the full range of efficiency classes at page 15. According to (EU) 2017/1369 6a.



← 43 →

WKes 653
GrandCru

Energy efficiency class:	
Energy consumption year / 24 hrs:	78 / 0.213 kWh
Max. Bordeaux bottles 0.75 l:	12¹
Total volume ² :	48 l
Noise output / noise class:	37 dB(A) / C
Climate rating:	SN (from +10 °C to +32 °C)
Door:	Glass door with stainless steel frame and SmartSteel
Side walls:	stainless steel with SmartSteel
Exterior dimensions in cm (h / w / d):	61.2 / 42.5 / 47.8



Controls

- LCD display in the interior, touch electronic
- Digital temperature display
- Alarm in case of malfunction: visual and acoustic
- Door alarm: acoustic
- Child lock

Wine compartment

- 1 temperature zone, which can set from +5°C to +20°C
- Convection cooling, fresh air supply via FreshAir activated charcoal filter
- Humidity regulation via adjustable fan
- LED lighting permanently on, dimmable
- Beech wood fittings
- 3 shelves

Key features

- HardLine
- Fixed door hinge, right
- Replaceable door seal
- Drawer for accessories
- Suitable for wall mounting



← 43 →

ZKes 453
Humidor

Energy efficiency class:	
Energy consumption year / 24 hrs:	162 / 0.443 kWh
Total net capacity:	39 l
Noise output:	40 dB(A)
Climate rating:	N (from +16 °C to +32 °C)
Door:	Glass door with stainless steel frame and SmartSteel
Side walls:	stainless steel with SmartSteel
Exterior dimensions in cm (h / w / d):	61.2 / 42.5 / 47.8



Controls

- LCD display in the interior, touch electronic
- Digital display of temperature and humidity
- Alarm in case of malfunction: visual and acoustic
- Door alarm: acoustic
- Child lock

Humidor

- 1 temperature zone, which can set from +16°C to +20°C
- Humidity range, adjustable between 68% to 75%
- Convection cooling, fresh air supply via FreshAir activated charcoal filter
- Humidity regulation via adjustable fan
- LED lighting permanently on, dimmable
- Spanish cedar wood fittings
- 2 shelves

Key features

- HardLine
- Fixed door hinge, right
- Replaceable door seal
- 2 presentation boxes
- Suitable for wall mounting

¹ These models are only bound for storing wine. Maximum DIN norm bordeaux bottles capacity (0.75 l) as per norm NF H 35-124 (H: 300,5 mm, Ø 76.1 mm)

² In accordance with Regulation EU 2019/2016 we indicate the total volume to the nearest integer (rounded off) and the volume of the frozen compartments and refrigeration compartments to one place after the decimal point.

You can find the full range of efficiency classes at page 15. According to [EU] 2017/1369 6a.

Stay in touch

Our catalogue programme

Ask your Liebherr dealer for our main catalogues for freestanding and fully integrated appliances and for our specials. All catalogues are also available for download at [home.liebherr.com](https://www.home.liebherr.com).



SmartDevice app: The smart companion for your Liebherr. Operate your appliances conveniently via app, receive important status messages and benefit from many other services relating to your fridge.



You can download our apps here.



This guarantee is granted free of charge for selected freestanding fridge-freezers. With our manufacturer's guarantee, you will not incur any costs for repair and service for 10 years. For more information, registration and guarantee conditions, go to: [home.liebherr.com/guarantee](https://www.home.liebherr.com/guarantee)



Liebherr-Great Britain Ltd.

Normandy Lane, Stratton Business Park, Biggleswade, SG18 8QB

Tel.: +44 (0) 3330 147 888

Email Sales: LGB.RefrigerationSales@liebherr.com

Customer Service: LGB.Refrigeration@liebherr.com

[home.liebherr.com](https://www.home.liebherr.com)

Brief explanation of features

Freshness technologies

Bio Fresh Professional	BioFresh-Professional offers even more flexibility for individual food storage.
Hydro Breeze	Cooling like a pro: Cold mist and a temperature in the safe of around 0 °C ensure a longer storage time and create a fabulous visual effect.
Fish & Seafood	The Fish & Seafood Safe stores fish and seafood at the optimum temperature of -2 °C; as professionally as your fishmonger.
Bio Fresh	The reliable BioFresh technology stores groceries at a temperature just above 0 °C, much cooler than in the rest of the appliance.
Bio Fresh Plus	Adjustable temperature range of 0 °C and -2 °C, BioFresh-Plus safe includes a versatile Fish & Seafood-Safe.
Bio Cool	Optimum humidity for fruit and vegetables via slider control and longer term food storage.
Easy Fresh	The air-tight safe allows humidity to rise keeping food fresher for longer.
Duo Cooling	Two separately controlled refrigeration circuits. The temperatures within the refrigerator and freezer compartments can be controlled independently.
No Frost	Defrosting is never needed as the freezer automatically defrosts itself.
Smart Frost	Defrosting is required much less often.
Super Cool	SuperCool boosts the cooling power until the food recently placed inside reaches the temperature of the rest of the contents.
Super Frost	SuperFrost increases the cooling power for a short time – this means the temperature remains constant when you place in unfrozen food.
Vario Temp	Freezer section becomes alternative additional cooling zone by setting an accurate temperature of between -2 °C and +14 °C.

Wine

Humidity Control	The humidity can be actively regulated in 5% increments between 50% and 80% RH.
Humidity Select	The humidity can be adjusted between two levels: Standard or High.
Temp Protect Plus	Two sensors constantly measure the temperature in the wine fridge. A notification is sent in the event of a critical change.*
Vibrate Safe	The fully vibration-insulated cooling system allows the wine to mature undisturbed.
Fresh Air	For a pure bouquet, an activated charcoal filter reliably binds odours of any kind.
UV Protect Plus	Triple protection: a tinted glass door with two layers of vacuum-deposited metal provides highly efficient protection from solar radiation.
UV Protect	Double protection: a tinted glass door with one layer of vacuum-deposited metal provides efficient protection from solar radiation.
1 Zone	With constant temperature throughout the interior, adjustable from +5 °C to +20 °C.
2 Zones	With two temperature zones, independently and precisely adjustable from +5 °C to +20 °C.
3 Zones	With three temperature zones, independently and precisely adjustable from +5 °C to +20 °C.

Convenience and flexibility

Soft System	The door closes gently even when fully loaded inside. The door automatically closes from an angle of approximately 30°.
Soft-Telescopic Rails	Fully extendible drawers run on telescopic rails and feature a convenient self-retraction mechanism with soft-closing.
Telescopic Rails	Drawers set on high-quality, smooth-running telescopic rails for reliable and secure opening and closing.
Touch & Swipe Display	Intuitive control – simply by touching and swiping on the colour display.
Touch Display	A Liebherr is really simple to use with a gentle tap of a finger on the clear touch display.

*SmartDevice/Smart app required

Brief explanation of features

Convenience and flexibility

Space Box	For flexible food storage: At a height of 250 mm, the space box offers lots of extra room even for really large frozen items.
Vario Space	For extra high storage space: Simply take out the individual freezer drawers and the glass horizontal dividers below and make space for extra tall frozen items.
Easy Open	EasyOpen means the freezer door can be opened multiple times one after another, conveniently and easily.
Self Closing Door	The door of the wine fridge closes smoothly by itself when opened less than 90°.
Easy Fill	Loading aid for easy stocking of the wine fridge. From an angle of 90°, the door remains open.
Presentation Board	Shows off exquisite wines and presents bottles that have been opened.

Design

Glass & Steel Interior	The interior features elegant glass and stainless steel elements.
Light Tower	The LightTower lighting concept evenly illuminates the interior while supporting the glass shelves. Flexible, space-saving, unique.
Light Column	LED light column from top to bottom evenly illuminates the interior. One-sided or double-sided depending on the series.
Mood Light	MoodLight – a highlight in your living environment: the indirect lighting design elegantly showcases the Water & Ice Centre and recessed grips.
Presentation Light	Effectively showcases the wine collection even when the glass door is closed. The brightness can be dimmed using the display.*
LED	Minimal heat generation, energy-saving and maintenance-free for optimum lighting.
Steel Interior	Not just an attractive design element, the SmartSteel stainless steel rear wall panel ensures balanced air circulation.

Water and ice

Water & Ice Centre	The Water & Ice Centre provides sufficient cold water, ice cubes and crushed ice around the clock.
Infinity Spring	Ice-cold water on tap with no heavy lifting of bottles and is better for our environment.
Ice Tower	Perfect for Parties: You will never run out of cold drinks. The 8 kg supply of ice cubes makes sure of that.
Ice Maker	Automatic IceMaker with fixed water connection.
Easy Twist Ice	Conjure up ice cubes quickly: Fill the tank with water, let it freeze and then release the finished ice cubes with a twist.

Connectivity

Smart Device ready	The SmartDeviceBox allows the appliance to be controlled and used via mobile devices. The SmartDeviceBox can be ordered as an accessory.
Smart Device	The SmartDeviceBox allows the appliance to be controlled and used via mobile devices. The SmartDeviceBox is already included.

Special product groups

Wine	The perfect range for wine aficionados.
Cigar	Quality storage for fine cigars.
Outdoor	Outdoor kitchens with refrigerators also provide convenience and perfect storage outdoors.

*SmartDevice/Smart app required