A 916 Litronic

LIEBHERR

Wheeled excavator



Generation

5

Operating weight

17,300 kg

Engine

115 kW / 156 HP
Stage IIIA (compliant)

Bucket capacity

0.8 m³

Performance

Robustly stable power,
strength and precision

Economy

A sound investment – optimum economy
and environmentally friendly

Reliability

Competence, consistency, innovation –
proven experience

Comfort

Ergonomic excellence – superior cabin
design for operator comfort and wellbeing

Maintainability

Service every step of the way –
simple, fast and reliable

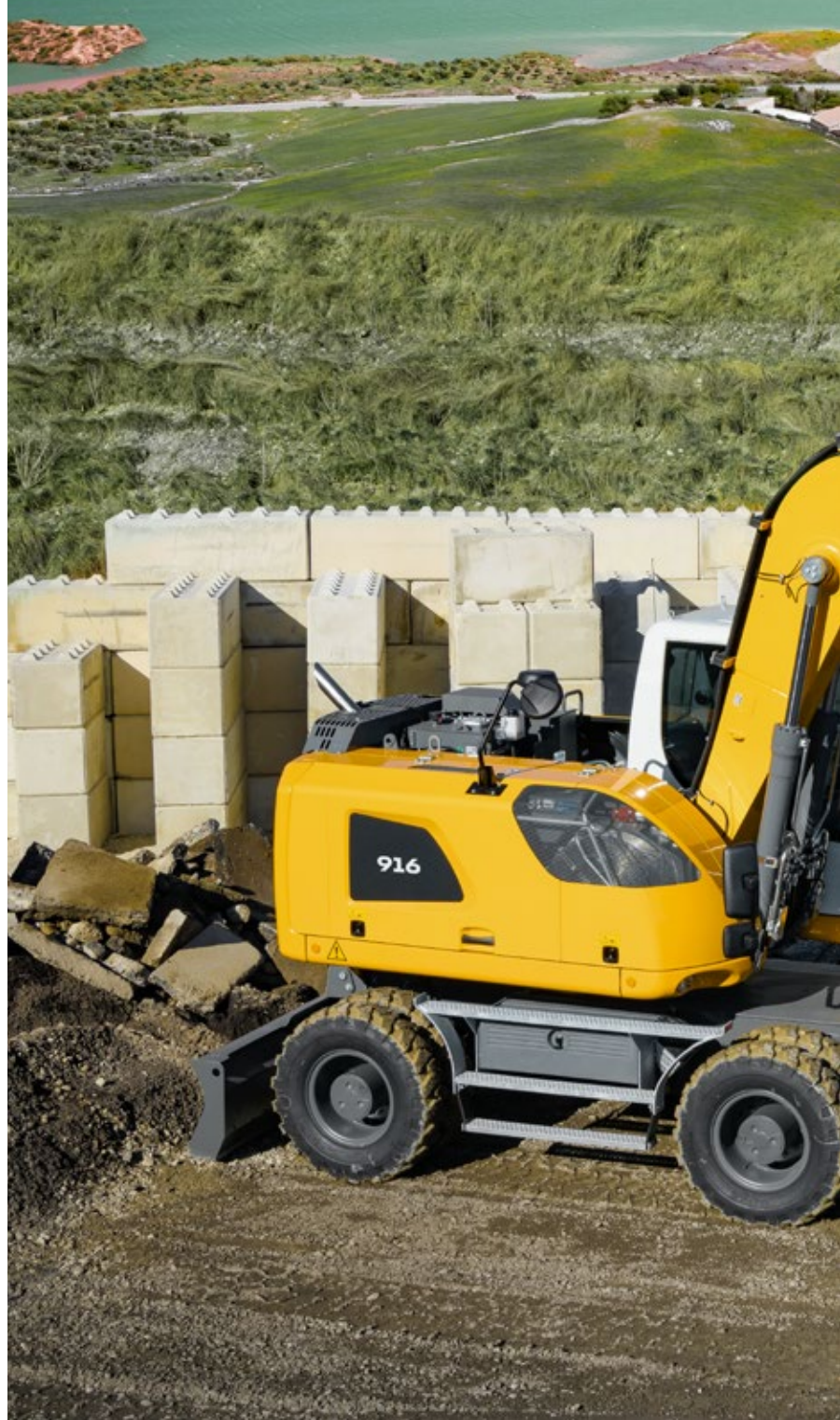



A 916 Litronic

Operating weight

17,300 kg

Engine

115 kW / 156 HP

Stage IIIA (compliant)

Bucket capacity

0.8 m³

Performance



Robustly stable power, strength and precision

Liebherr wheeled excavators are designed for maximum productivity. Large grab capacity, high payloads and rapid working cycles satisfy all the requirements for efficient site operations. A wide range of attachment versions enhances excavator use.

Maximum performance

Versatile and powerful

Liebherr developed the powerful A 916 to be productive and efficient in all applications. Road, sewer and pipeline construction as well as classic earthmoving operations are just some examples of its scope. The machine concept of the A 916 delivers some important benefits. Excellent weight distribution with compact dimensions combines enormous versatility and outstanding stability as well as high capacity.

Working faster

Many years of experience in the development and production of hydraulic excavators and systems allow us to harmonize the components perfectly. As a result, Liebherr hydraulic excavators feature rapid, fluid movements combined with high precision. These properties are also available when simply driving the machine. The speed and precision of the machine can be adjusted using the MODE switch to suit a new task, which also saves fuel.

Precise work

Working with precision

The Liebherr joysticks enable the operator to intuitively and sensitively control the Liebherr hydraulic system to complete even the most challenging tasks quickly. Liebherr has been using an infinitely variable proportional controller with four axes for many years. The slim, ergonomically designed proportional sensors deliver additional functionality to the classic machine controller without having to reach for additional controls. Typical functions include high and medium pressure movements for tools as well as lowering the machine outrigger. Buttons on the joysticks, which the operator can configure, deliver additional convenience and functions.



Constant power

- Powerful and robust construction machinery motor for continuous use at full load
- 4.5 liter displacement with high torque for fuel-efficient operation at low engine speeds
- Turbo loader with intercooling – high output at low fuel consumption
- Specially developed for use in construction machinery



Digging force

- High digging and breakout force
- Continuously high digging performance even in tough ground
- More digging force for faster results



Travel drive

- High traction for fast acceleration and powerful engine permit top speed on hills
- Reduces unproductive travel time between tasks and on the building site
- Faster on site – More productive

Economy



A sound investment – optimum economy and environmentally friendly

Liebherr wheeled excavators are machines that combine high productivity with excellent levels of economy – and all this comes as standard from the factory. On request, the efficiency of each wheeled excavator can be boosted further with a Liebherr productive bucket, fuel-saving Liebherr hydraulic oil or a Liebherr quick coupling system, all of which provide more return from each operating hour.

Maximum efficiency

Powerful construction machinery engine

The A 916 features a robust, modern four-cylinder engine which is powerful, fuel-efficient and reliable. The engine power is demonstrated in the form of high torque values at low speeds, thereby using its speed range superbly. Intensive long-term tests have proven the resilience and quality of the installed components. The engine satisfies the high quality standards demanded by Liebherr even in the most adverse conditions. This ensures reliability throughout the service life of the machine.

Engine idling

The standard automatic idling function reduces the engine speed to idle as soon as the operator takes his hand from the joystick so that no hydraulic function is activated. Proximity sensors in the joystick levers restore the original engine speed as soon as the operator's hand is moved towards the lever again. This ensures that the set engine speed is available immediately. The result is a combination of fuel saving and reduced noise levels.

Increased productivity

Liebherr quick coupling systems

To boost the productivity of your construction machines, Liebherr offers a broad range of working tools for different fields of application. The A 916 can be equipped with various changeover systems to enable it to swap between tools quickly and safely. Such systems can significantly reduce time and operating costs and improve the machine's versatility.

Automatic digging brake and swing axle lock

The automatic digging brake ensures that manual actuation of the brake pedal is no longer required. When the machine is stationary, the digging brake engages automatically. This results in faster work processes and enhanced productivity, particularly during operation with frequent relocation of the excavator. Furthermore, the automatic digging brake can be linked with the automatic swing axle lock. When the machine is deployed and working, the swing axle locks automatically and thereby provides optimum stability.



Liebherr Power Efficiency (LPE) System

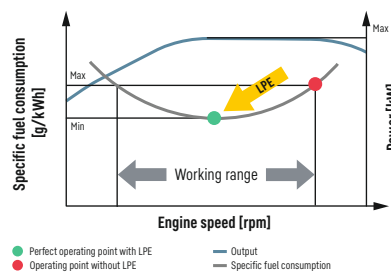

ECO mode

- For particularly cost-effective and green working practices
- Fuel consumption reduction of up to 20%
- 80% of all jobs are possible in this mode without any loss of performance or speed

Low fuel consumption thanks to intelligent machine control

- Liebherr-Power Efficiency (LPE) optimises the interaction of the drive components in terms of efficiency
- LPE enables machine operation in the area of the lowest specific fuel use for reduced consumption and greater efficiency with the same performance

Smart cooling system

- Needs-based cooling using thermostatic control
- Fuel-efficient
- Accelerated warm-up phase
- Guaranteed uniform oil quality due to constant oil temperature
- The service life of the drive components is extended

Reliability



Competence, consistency, innovation – proven experience

Reliability offers safety. Safety that significantly influences the success of a project. Whatever the weather, Liebherr stands for safety – with reliable construction machines and customer-oriented sales and service partners. This means a Liebherr construction machine is exactly what it should be: an investment that pays off.

High machine availability

Quality and competence

Our product experience, our understanding of technical design and feedback from customers, along with sales and service, form the basis for the use of pioneering ideas and have always been an integral part of our recipe for success. In addition, Liebherr has been delivering great production depth and system solutions for decades. Key components such as the electronic components, slewing ring, slewing drive and hydraulic cylinders are developed and manufactured in-house. Our great production depth guarantees the highest quality possible and allows the components to be coordinated perfectly.

Robust design

All steel components are designed by Liebherr and manufactured in-house or in partnership with long-term suppliers from high strength steel designed to withstand the harshest requirements, guarantee high torsion resistance and excellent absorption of forces to ensure a long service life.

Greater safety

Safety

In addition to the performance and economy of a wheeled excavator, the other main focus is on the safety of personnel and the machine. A wide range of equipment such as pipe fracture safety devices on lifting and stick cylinders, load holding valves on outriggers, overload warning device, roll-over protection system (ROPS) and the emergency exit through the rear window deliver maximum safety for every job.

Maximum stability

A robust undercarriage with securely welded outriggers deliver safe footing, maximum stability and a long service life. The stabilizer blade as well as the outriggers have been designed for the toughest scenarios, allowing the machine to reliably carry out its work at full load.



QPDM – quality and process data management

- QPDM allows production data to be logged, documented and evaluated
- Automation of documentation and test specifications
- Ability to handle large quantities and maintain uniform high quality



Excellent all-round visibility

- The camera for rear-view and the optional lateral monitoring gives the driver an optimal view of his working area and the surrounding machine area at all times
- Optional working lights provide perfect illumination of the area around the machine in poor light, thus improving safety for both personnel and the machine



Mitas EM 22 twin tyres

- Specially developed twin tyres for increased stability when the machine's outriggers are not extended
- Long service life through increased wear resistance
- High traction using V tread studs

Comfort



Ergonomic excellence – superior cabin design for operator comfort and wellbeing

The Liebherr excavator cab comes with generous dimensions and an ergonomic design. The operator's seat is individually adjustable, the control panel is arranged clearly and helpfully and the all-round visibility is perfect. Automatic air-conditioning ensures the right temperature at all times in the "Liebherr feel-good cab".

First-class cab

Productive working environment

The spacious Liebherr cab offers plenty of room for long working days and ensures the best platform for all-round visibility thanks to large window areas and narrow bars. All gear levers and control panels are located within reach and fit the ergonomic concept of the operator's cab perfectly. The temperature, fan setting and the standard automatic air-conditioning's head, chest and foot level air vents can be adjusted with ease using touchscreen control.

Operator seats

The Standard and Comfort operator's seat versions deliver maximum comfort. Even the Standard operator's seat has been manufactured with high-quality materials and has an extensive selection of standard equipment including pneumatic suspension, seat heating, headrest, lumbar support and much more. A luxury which we believe every construction machine should provide.

Smooth operation

The use of visco-elastic mounts, good noise insulation and modern, smooth Liebherr diesel engines minimise noise emissions and vibrations.

Comfortable operation

Radio with hands-free device

The optional Liebherr radio is MP3-compatible, has a USB connection and can be used as interface for the integral hands-free kit. If the machine operator connects his smartphone to the radio using Bluetooth, the touchscreen can be used to control phone calls. This means that all media, including the radio, MP3 or phone calls, are controlled using a central unit which provides greater clarity, simplicity and comfort.

Control unit

The large touchscreen provides the operator with a fast, uncomplicated interface which delivers all the information required for working with the machine. A flat, intuitive menu system ensures that it can be readily understood so that the control unit can be used in a highly productive way.



Refuelling

- Using the optional refuelling pump, the machine can be refuelled directly from a fuel container
- An integral tank hose and an automatic shut off when the tank is full deliver greater comfort and short refuelling times
- Topping up – simple, quick and safe



Sliding two-piece windshield

- Unrestricted view of the working area by sliding in the windshield
- Simple mechanism for rapid and intuitive opening
- Windscreen can be split in two



Intuitive operation

- Display of the machine data and camera image on the 9-inch indicating unit with touchscreen and direct access via menu bar
- 20 user-programmable memory slots for working tools, which can be used for quickly and easily setting the oil pressure and oil flow at the push of a button when changing tools

Maintainability



Service every step of the way – simple, fast and reliable

Liebherr wheeled excavators are not only powerful, robust, precise and efficient, they also impress with the service-orientated machine design. Maintenance is performed quickly, simply and safely. This reduces maintenance costs and keeps machine downtimes to a minimum.

Simplified maintenance concept

Service-based machine design

The service-based machine design guarantees short servicing times, thus minimising maintenance costs due to the time it saves. All the maintenance points are easily accessible from the ground and easy to reach due to the large, wide-opening service doors. The enhanced service concept places the maintenance points close to each other and reduces their number to a minimum.

CAN bus system

Operating data is collected and transferred to the control center using an extended CAN bus system for machine monitoring and diagnostic purposes. This enables you to check the status of your machine at any time and ensure that it operates reliably.

Your competent service partner

Strong partner – strong service

Liebherr facilities and service partners all over the world provide you with competent, reliable and efficient support – any time, any place. Speed and reliability are an integral part of the services provided by Liebherr because quick response times mean less downtime and help to restore your machine's productivity swiftly.

Competent advice and service

Competent advice is a given at Liebherr. Experienced specialists provide advice for your specific requirements: application-oriented sales support, service agreements, cost effective repair alternatives and original parts management.

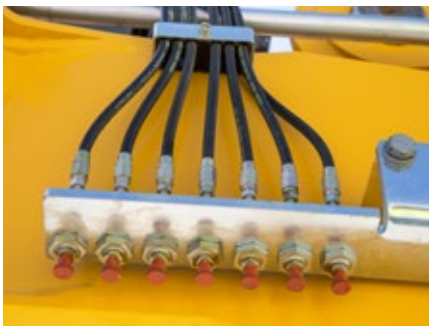

Reliable lubrication

- Accessible lubrication points are grouped together on a strip, thus reducing maintenance time
- Single lubrication nipples are easily accessible



Excellent service access

- Large, wide-opening service doors
- Engine oil, fuel, air and cab air filters are easily and safely accessible from the ground
- The oil level in the hydraulic tank can be checked from the cab
- Standard magnetic rod in the hydraulic tank as reliable service indicator



Rapid spare parts service

- Spare parts service is available for our dealers around the clock
- Electronic spare parts catalogue: Fast and reliable selection and ordering via the Liebherr online portal
- With online tracking, the current processing status of your order can be viewed at any time

Wheeled excavator A 916 Litronic overview

Excellent machine concept for maximum reliability

- Robust design made of high strength steel
- Solid, welded outriggers
- Load holding valves on all outriggers
- Liebherr hydraulic cylinders with standard pipe fracture safety devices for lifting and stick cylinders
- Overload warning device
- Roll-over protection system (ROPS)
- Twin tyres

Superior technology for highest economy

- Powerful and robust construction machinery motor for continuous use at full load
- Liebherr-Power-Efficiency (LPE) – Liebherr's smart engine controller
- Load-sensing-control
- Sensor-controlled automatic idling system

Simplified maintenance concept for maximum productivity

- Service-enhanced machine structure with easy access to the maintenance points
- Grouped lubrication points on a strip for simple manual lubrication
- Liebherr Hydraulic Plus – oil with an extended service life of up to 8,000 operating hours
- Highly qualified, experienced trained personnel provide competent care





Ergonomic operator's work station for maximum comfort

- High quality operator's seats in a range of versions
- Control console connected to the seat and ergonomic joysticks
- Folding control console, left
- Proportional control with 4-way mini-joystick
- Automatic air-conditioning system
- Control Unit – 9" large colour touchscreen
- Rear and side monitor
- Convenient radio control with hands-free kit
- Tool Control for working tools (optional)
- LED headlights (optional)
- Large windows
- Sliding two-piece windscreen

Perfect combination for highest possible performance

- Powerful 4-cylinder in-line engine with Common-Rail injection system
- Liebherr hydraulic system for high digging and breakout forces with combined, fluid movements
- Flexible configuration of the machine with various attachment and tool versions and options

Technical data



Diesel engine

Rating per ISO 9249	115 kW (156 HP) at 1,800 RPM
Model	Cummins QSB4.5
Type	4 cylinder in-line
Bore / Stroke	107 / 124 mm
Displacement	4.5 l
Engine operation	4-stroke diesel Common-Rail Turbo-charged and after-cooled Reduced emissions
Air cleaner	Dry-type air cleaner with pre-cleaner, primary and safety elements
Engine idling	Sensor controlled
Electrical system	
Voltage	24 V
Batteries	2 x 135 Ah / 12 V
Alternator	Three-phase current 28 V / 90 A
Stage IIIA (compliant)	
Harmful emissions values	In accordance with ECE-R.96 Power Band I
Fuel tank	250 l



Cooling system

Diesel engine	Water-cooled Compact cooling system consisting cooling unit for water, hydraulic oil and charge air with stepless thermostatically controlled fan, fans for radiator cleaning can be completely folded away
----------------------	--



Hydraulic controls

Power distribution	Via control valves with integrated safety valves, simultaneous and independent actuation of chassis, swing drive and equipment
Servo circuit	
Equipment and swing	With hydraulic pilot control and proportional joystick levers
Chassis	Electro-proportional via foot pedal
Additional functions	Via switch or electro-proportional foot pedals
Proportional control	Proportionally acting transmitters on the joysticks for additional hydraulic functions



Hydraulic system

Hydraulic pump	Liebherr axial piston variable displacement pump
For equipment and travel drive	
Max. flow	300 l/min.
Max. pressure	350 bar
Hydraulic pump regulation and control	Liebherr-Synchron-Comfort-system (LSC) with electronic engine speed sensing regulation, pressure and flow compensation, torque controlled swing drive priority
Hydraulic tank	130 l
Hydraulic system	max. 300 l
Filtration	1 main return filter with integrated partial micro filtration (5 µm)
MODE selection	Adjustment of engine and hydraulic performance via a mode pre-selector to match application, e.g. for especially economical and environmentally friendly operation or for maximum digging performance and heavy-duty jobs
S (Sensitive)	Mode for precision work and lifting through very sensitive movements
E (Eco)	Mode for especially economical and environmentally friendly operation
P (Power)	Mode for high performance with low fuel consumption
P+ (Power-Plus)	Mode for highest performance and for very heavy duty applications, suitable for continuous operation
Engine speed and performance setting	Stepless alignment of engine output and hydraulic power via engine speed



Swing drive

Drive	Liebherr axial piston motor with integrated brake valve and torque control, Liebherr planetary reduction gear
Swing ring	Liebherr, sealed race ball bearing swing ring, internal teeth
Swing speed	0-10.0 RPM stepless
Swing torque	54 kNm
Holding brake	Wet multi-disc (spring applied, pressure released)



Cab

Cab	ROPS safety cab structure (roll-over protection system) with individual windscreens or featuring a slide-in subpart under the ceiling, work headlights integrated in the ceiling, a door with a sliding window (can be opened on both sides), large stowing and depositing possibilities, shock-absorbing suspension, sound damping insulating, tinted laminated safety glass, separate window shades for the sunroof window and windscreen
Operator's seat Standard	Air cushioned operator's seat with 3D-adjustable armrests, headrest, lap belt, seat heater, manual weight adjustment, adjustable seat cushion inclination and length and mechanical lumbar vertebrae support
Arm consoles	Joysticks with control consoles and swivel seat, folding left control console
Operation and displays	Large high-resolution operating unit, self-explanatory, colour display with touchscreen, video-compatible, numerous setting, control and monitoring options, e.g. air conditioning control, fuel consumption, machine and attachment parameters
Air-conditioning	Automatic air-conditioning, recirculated air function, fast de-icing and demisting at the press of a button, air vents can be operated via a menu; recirculated air and fresh air filters can be easily replaced and are accessible from the outside; heating-cooling unit, designed for extreme outside temperatures, sensors for solar radiation, inside and outside temperatures (country-dependent)



Undercarriage

Drive	Oversized two speed power shift transmission with additional creeper speed, Liebherr axial piston motor with functional brake valve on both sides
Pulling force	127 kN
Travel speed	0- 3.5 km/h stepless (creeper speed off-road) 0- 7.0 km/h stepless (off-road) 0-13.0 km/h stepless (creeper speed on-road) 0-37.0 km/h stepless (road travel)
Driving operation	Automotive driving using accelerator pedal, cruise control function: storage of variable accelerator pedal positions, both off-road and on-road
Axles	Manual or automatic hydraulically controlled front axle oscillation lock
Service brake	Two circuit travel brake system with accumulator; wet and backlash-free disc brake
Automatic digging brake	Works automatically when driving off (accelerator pedal actuation) and when the machine is stationary (engagement); the digging brake engages automatically - can be coupled with automatic swing axle lock
Holding brake	Wet multi-disc (spring applied, pressure released)
Stabilization	Rear outriggers + front stabilizer blade (stabilizer blade adjustable during travel)



Equipment

Type	High-strength steel plates at highly-stressed points for the toughest requirements. Complex and stable mountings of equipment and cylinders
Hydraulic cylinders	Liebherr cylinders with special sealing and guide system and, depending on cylinder type, shock absorption
Bearings	Sealed, low maintenance



Complete machine

Lubrication	Standard: decentralised lubrication strip on the mono boom and single lubrication points on the stick; optional: Liebherr central lubrication system for uppercarriage and equipment, automatically
Noise emission	
ISO 6396	71 dB(A) = L_{pA} (inside cab)
2000/14/EC	100 dB(A) = L_{WA} (surround noise)

Dimensions

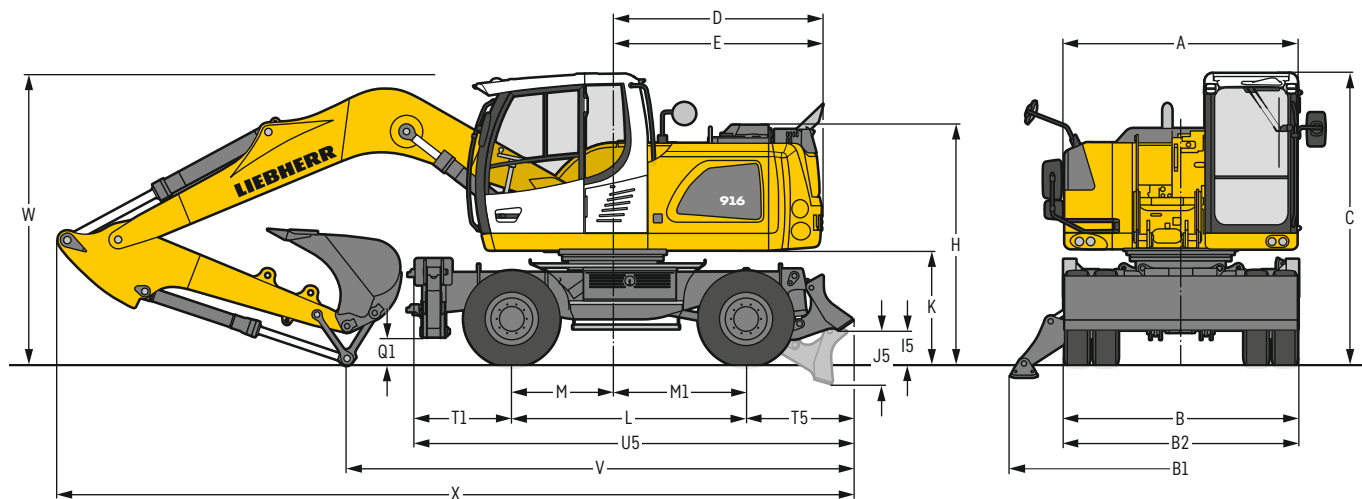

	mm
A	2,525
B	2,550
B1	3,695
B2	2,550
C	3,165
D	2,250
E	2,270
H	2,590
I5	380
J5	585
K	1,230
L	2,540
M	1,100
M1	1,440
Q1	305
T1	1,135
T5	1,153
U5	4,830

E = Tail radius
Tyres 10.00-20

	Stick	Mono boom 5.00 m
		Rear outriggers + front blade
	m	mm
V	2.65	5,500*
W	2.65	3,150*
X	2.65	8,650*

Dimensions are with equipment over steering axle

* Equipment over digging axle for shorter transport dimensions

W = Max. ground clearance including approx. 150mm piping

Backhoe bucket

with mono boom 5.00 m

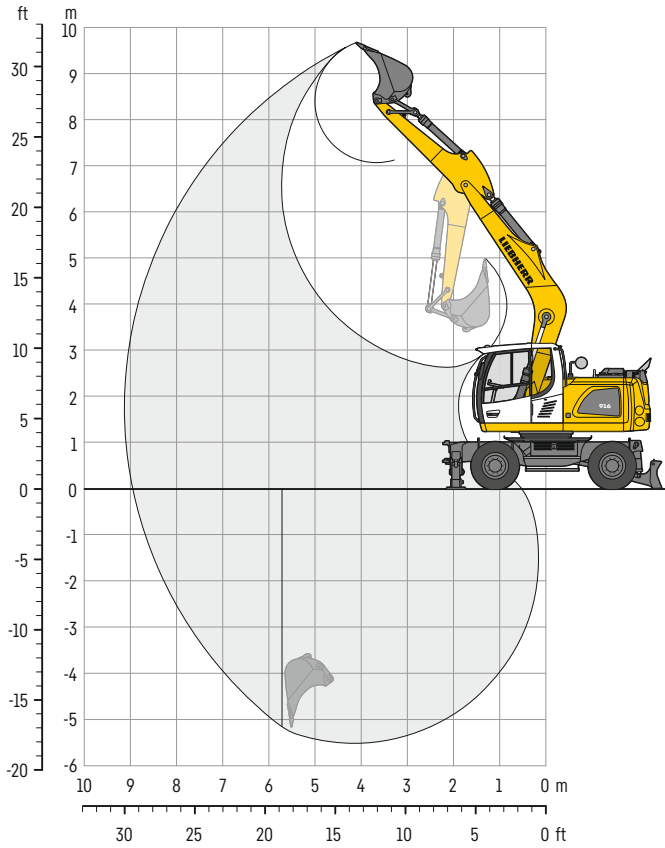

Digging envelope

without quick coupler	
Stick length	m 2.65
Max. digging depth	m 5.50
Max. reach at ground level	m 8.95
Max. dumping height	m 7.05
Max. teeth height	m 9.75
Min. equipment radius	m 2.61

Digging forces

without quick coupler	
Max. digging force (ISO 6015)	kN 61.8 t 6.3
Max. breakout force (ISO 6015)	kN 86.2 t 8.8

Max. breakout force with ripper bucket 114.0 kN (11.6 t)

Operating weight

The operating weight includes the basic machine with 8 tyres plus intermediate rings, mono boom 5.00 m, stick 2.65 m and bucket 1,050 mm / 0.80 m³.

Undercarriage versions	Weight (kg)
A 916 Litronic with rear outriggers + front blade	17,300

Buckets Machine stability per ISO 10567* (75% of tipping capacity)

Cutting width mm	Capacity ISO 7451 m ³	Weight kg	Stabilizers raised		Rear outriggers + front blade down	
			Stick length (m)		Stick length (m)	
1,050 ¹⁾	0.80	510	2.65		2.65	
1,050 ²⁾	0.80	510	2.65		2.65	

* Indicated loads are based on ISO 10567 and do not exceed 75% of tipping or 87% of hydraulic capacity, max. stick length without quick coupler, lifted 360° on firm with blocked oscillating axle

¹⁾ Teeth Liebherr system Z 35 CL

²⁾ Teeth CAT system J300

Max. material weight ■ = ≤ 1.8 t/m³, ■ = ≤ 1.5 t/m³, ▲ = ≤ 1.2 t/m³, - = not authorised

Lift capacities

with mono boom 5.00 m

Stick 2.65 m

m	Undercarriage stabilized		3.0 m		4.5 m		6.0 m		7.5 m		m		
	rear	front											
7.5	-	-		3.1*	3.1*					2.0*	2.0*	5.1	
	Outriggers	Blade		3.1*	3.1*					2.0*	2.0*		
6.0	-	-		3.8*	3.8*	2.7	2.9*			1.7*	1.7*	6.5	
	Outriggers	Blade		3.8*	3.8*	2.9*	2.9*			1.7*	1.7*		
4.5	-	-		4.2	4.6*	2.7	4.1*			1.7*	1.7*	7.3	
	Outriggers	Blade		4.6*	4.6*	4.1*	4.1*			1.7*	1.7*		
3.0	-	-	7.0	9.3*	3.9	5.9*	2.5	4.0	1.7	2.5*	1.7	1.7*	7.7
	Outriggers	Blade	9.3*	9.3*	5.9*	5.9*	4.1	4.7*	2.5*	2.5*	1.7*	1.7*	
1.5	-	-		3.5	5.8	2.4	3.8	1.7	2.7	1.6	1.8*	7.8	
	Outriggers	Blade		6.1	7.1*	4.0	5.2*	2.8	3.2*	1.8*	1.8*		
0	-	-	4.4*	4.4*	3.3	5.6	2.2	3.7	1.6	2.5*	1.6	2.0*	7.6
	Outriggers	Blade	4.4*	4.4*	5.8	7.7*	3.8	5.5*	2.5*	2.5*	2.0*	2.0*	
-1.5	-	-	5.8	7.1*	3.2	5.5	2.2	3.6			1.8	2.5*	7.0
	Outriggers	Blade	7.1*	7.1*	5.7	7.5*	3.7	5.4*			2.5*	2.5*	
-3.0	-	-	5.9	9.4*	3.2	5.5	2.2	3.7			2.2	3.5*	6.0
	Outriggers	Blade	9.4*	9.4*	5.8	6.5*	3.8	4.1*			3.5*	3.5*	

Height Can be slewed through 360° In longitudinal position of undercarriage Max. reach * Limited by hydr. capacity

The lift capacities on the stick end without attachment are stated in metric tons (t) and are valid on a firm, level supporting surface with blocked oscillating axle. These capacities can be slewed through 360° with the undercarriage in the transverse position. Capacities in the longitudinal position of the undercarriage (±15°) are specified over the steering axle with the stabilizers raised and over the rigid axle with the stabilizers down. Indicated loads based on the ISO 10567 standard and do not exceed 75% of tipping or 87% of hydraulic capacity. Lifting capacity of the excavator is limited by machine stability and hydraulic capacity.

In accordance with the harmonised European Standard EN 474-5, hydraulic excavators used for lifting operations must be equipped with pipe fracture safety valves, an overload warning device, a load hook and a lift capacity chart.

Attachments

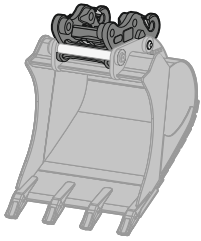

Quick coupling system SWA 48

Function		mechanical
Outer dimension	mm	480
Weight	kg	220

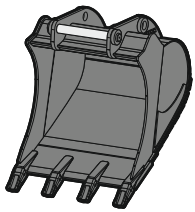

Backhoe bucket 03

Mountings		SWA 48 mechanical	SWA 48 mechanical	direct mounting	direct mounting
Cutting width	mm	1,050	1,050	1,050	1,050
Capacity	m ³	0.80	0.80	0.80	0.80
Weight ¹⁾	kg	530	530	510	510
Teeth Liebherr system Z 35 CL ²⁾		4		4	
Teeth CAT system J300 ^{3) 4)}			4		4

¹⁾ including tooth system with tooth holder and teeth

²⁾ Liebherr tooth system, tooth holder (two arm)

³⁾ CAT tooth system⁴⁾, tooth holder (single arm)

⁴⁾ not an original part

Equipment

Undercarriage

Stabilization and driving	
Individual control, two outriggers	•
Rear outriggers, front stabilizer blade 2,550 mm	•
Speeder 37 km/h	•
Twin tyres, Mitas EM-22, 10.00-20 PR 16	•
Intermediate rings (MH 3)	•
Options	
Electric slip ring (12-ways) including angle sensor	•
Lubrication undercarriage (decentral), manual (grease points)	•
Storage compartment left	•

Uppercarriage

Hydraulic and engine	
Hydraulic oil, Liebherr hydraulic basic 100 (0 to +55 °C)	+
Hydraulic oil, Liebherr hydraulic HVI (-20 to +40 °C)	•
Lubricants and operating fluids standard (-20 to +40 °C)	•
Preheating fuel	+
Options	
Standard counterweight	•
Rear view monitoring with camera	•
Lubrication uppercarriage and equipment (decentralised), manual (grease points)	•

Equipment

Boom	
Mono boom 5.00 m	•
Pipe fracture safety valve stick cylinder	•
Headlights on boom, halogen, 2 pieces	•
Stick and attachment mounting	
Stick 2.65 m	•
Quick coupler SWA 48 mechanical	+
Mounting: direct mounting	•

Cab

Interior	
2" seat belt with retractor	•
Exterior mirror standard	•
Operator's seat Standard	•
Travel alarm system, switchable	+
Automatic air conditioning	•
Steering wheel, slim version (steering wheel rims and spokes)	•
Wheel steering	•
LiDAT, vehicle fleet management	+
Radio preparation	•
Exterior	
Roof window, laminated glass	•
Windscreen, laminated glass, two pieces	•
Licence plate holder with light	+
Amber beacon, on cab, LED double flash, 1 piece	•
Headlights on cab, front, halogen, 2 pieces (under rain shield)	+

Control

Safety and operation	
Digging brake, automatic	•
Slewing gear brake on control panel	•
Overload warning device	•
Hydraulic and control	
High pressure circuit with Tool Control	•
Medium pressure circuit	+
Joystick	
Change in travelling direction, rocker switch in left joystick	•
Travel alarm system, rocker switch in the right joystick, switchable	+
Handrest (elevation) for joystick	•
Horn, button on left joystick	•
Proportional control (left / right)	•
Short key button on joystick configurable	•

General

Acceptance and transport	
Export packaging	•
Vandalism packaging	+

• = Standard, + = Option

* = country-dependent

Options and / or special equipment, supplied by vendors other than Liebherr, are only to be installed with the knowledge and approval of Liebherr in order to retain warranty.

The Liebherr Group



Global and independent: more than 70 years of success

Liebherr was founded in 1949 when, with the development of the world's first mobile tower crane, Hans Liebherr laid the foundations for a family business now employing nearly 51,000 people and comprising over 140 companies across every continent.

The parent company is Liebherr-International AG in Bulle, Switzerland, whose associates are exclusively members of the Liebherr family.

Leaders and pioneers

Liebherr is a pioneer and its forward-looking approach has seen it make important contributions to technology history over a wide variety of industries. Employees throughout the world continue to share the courage of the founder, sharing a passion to produce innovative products and a determination to provide world-leading equipment and machinery.

Diversified portfolio

The company is one of the world's biggest construction equipment manufacturers and provides high-quality, user-oriented products and services to sectors including: earthmoving, material handling, deep foundations, mining, mobile and crawler cranes, tower cranes, concrete production and distribution, maritime cranes, aerospace and transportation, gear technology and automation, refrigeration and freezing, components and hotels.

Customised care

Liebherr solutions are characterised by precision, implementation and longevity. The company is committed to technological excellence and to providing customers with solutions that match their needs exactly. That customer focus does not end with delivery of a product but continues through a comprehensive range of back-up and support services.

www.liebherr.com

Liebherr-Hydraulikbagger GmbH

Liebherrstraße 12 • 88457 Kirchdorf/Iller, Germany • Phone +49 7354 80-0 • Fax +49 7354 80-72 94
info.lhb@liebherr.com • www.liebherr.com • www.facebook.com/LiebherrConstruction