

# SCNsdh 5253

Fridge-freezer with EasyFresh and VarioTemp

○ Prime

# LIEBHERR

Freestanding



Freestanding

**LIEBHERR**

# SCNsdh 5253 LHH

Fridge-freezer with EasyFresh and VarioTemp

◊ Prime

← 60 →



Vario Space

Energy consumption (kWh/yr) / Star rating	194 / 6.0 kWh <sup>1</sup>
Total volume	332 l <sup>2</sup>
Volume	Freezer compartment: 103 l
Noise output	33 dB(A)
Climate rating	SN-T (+10 °C to +43 °C)
Door / Side walls	SmartSteel / silver
Exterior dimensions in cm (h / w / d)	185.5 / 59.7 / 67.5 <sup>3</sup>
<b>Controls</b>	
Type of Control	2.4" TFT-colour display behind-the-door, touch- & swipe Digital temperature display for fridge and freezer compartments
Door alarm	visual and acoustic
Alarm in case of malfunction	visual and acoustic
<b>Fridge compartment</b>	
Forced air system	PowerCooling with FreshAir activated charcoal filter
Door interior	Premium GlassLine storage shelves with bottle holder, removable VarioBoxes, adjustable egg tray
VarioSafe	yes
Bottle shelf	Bottle shelf
Interior light	LED light panel, both sides
Fruit and vegetable bins	1 EasyFresh safe on telescopic rails
<b>Freezer compartment</b>	
Interior light	LED lighting
Number of drawers	3 drawers, VarioSpace
<b>Features</b>	
Side-by-Side concept	Side wall heating right, suitable for combination with other refrigerators, freezers and/or wine appliances
Door hinges	left
Replaceable door seal	yes
EAN-Nr.	4016803136774

<sup>1</sup> To achieve the indicated energy consumption level, the wall spacers provided with the appliance must be used. These increase the appliance depth by approximately 1.5 cm. If the wall spacers are not used, the appliance will remain fully functional, but will have a slightly higher energy consumption level.

<sup>2</sup> In accordance with Regulation EU 2019/2016 we indicate the total volume to the nearest integer (rounded off) and the volume of the frozen compartments and refrigeration compartments to one place after the decimal point.

## Features

---



**EasyFresh**

The guarantee of market freshness in the home is our EasyFresh-Safe. Whether it's unpackaged vegetables or fruit, this ensures optimal storage for everything. Thanks to the air-tight closure, the food causes the humidity in the safe to rise. This keeps the food fresh for a long time.



**NoFrost**

When you open your freezer, you want to see frozen food – and certainly not ice and frost. NoFrost protects the freezer compartment from unwanted icing, which consumes a lot of energy and can be expensive. NoFrost means no more tedious and time-consuming defrosting of the freezer compartment, more time for other things – and saving money.



**DuoCooling**

DuoCooling uses two completely separate refrigeration circuits to ensure no air is exchanged between the fridge and freezer compartments. The food neither dries out nor is odour transferred. This means throwing less away, shopping less often, but saving more and greater enjoyment.



**SmartSteel**

Thanks to its SmartSteel surface, the purist design language of the appliance is the perfect accent to any kitchen. The horizontal polish brings out the stainless steel and gives it a silky sheen and a pleasant feel. The special coating minimises fingerprints and makes the surface insensitive to scratches. So nothing disturbs the high-quality exterior.



**VarioTemp**

Experience plenty of scope when storing food: Thanks to VarioTemp, you can set the freezer compartment between -15 °C to -26 °C or convert to fridge or cellar compartment when additional cooling space required with an adjustable temperature from -2 °C to +14 °C.



**LightTower**

Enjoy an optimally illuminated interior: the LightTower shows off the food in its best light and is positioned so that all of your filled fridge is illuminated at all times. The flush mounting of the LightTower in the side walls means there is also more space for your food.

# Technical drawing

---

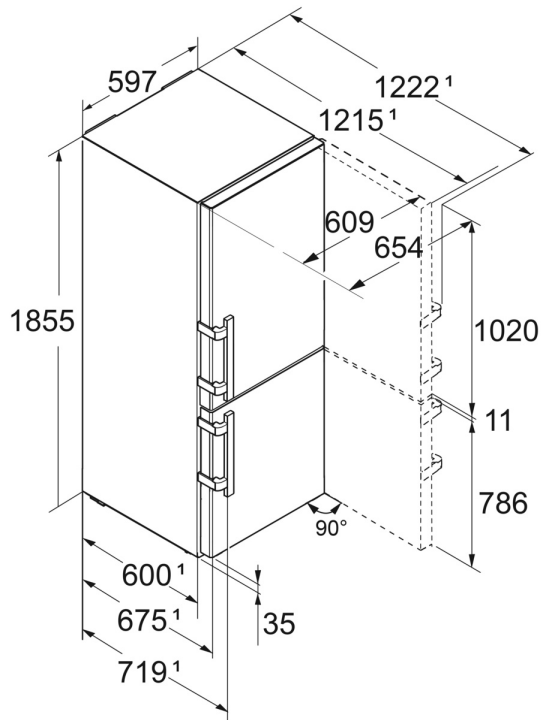

Products and their details are staged for advertising purposes. Whilst every effort is made to ensure all specifications and information in this flyer are accurate, Liebherr reserves the right to make changes without notification. Where actual appliance measurements, specifications, and ratings are crucial, we recommend that the actual appliance installation instructions that accompany each appliance be checked. Liebherr will not be liable for any damage. (21.03.2024)

