

User Guide

Quality, Design and Innovation

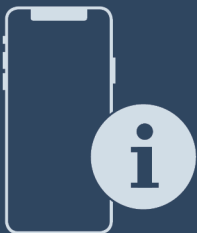

[home.liebherr.com/fridge-manuals](http://home.liebherr.com/fridge-manuals)

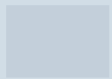





# LIEBHERR

# Contents

<b>1</b>	<b>The appliance at a glance.....</b>	<b>3</b>		
1.1	Included in delivery.....	3	6.2.20	Temperature alarm ..... 33
1.2	Overview of appliance and equipment.....	3	6.2.21	Door alarm ..... 34
1.3	Special features.....	3	6.2.22	Alarm simulation ..... 35
1.4	Range of appliance use.....	4	6.2.23	Alarm relay ..... 35
1.5	Sound emission of the appliance.....	5	6.2.24	Demo mode ..... 36
1.6	Conformity.....	5	6.2.25	Resetting to factory settings ..... 37
<b>2</b>	<b>General safety instructions.....</b>	<b>5</b>	6.3	Messages..... 37
<b>3</b>	<b>Functionality of the Touch display.....</b>	<b>7</b>	6.3.1	Warnings..... 37
3.1	Navigation and symbol explanation.....	7	6.3.2	Reminders..... 39
3.2	Menus.....	8	<b>7</b>	<b>Equipment..... 40</b>
3.3	Sleep mode.....	8	7.1	Safety lock..... 40
<b>4</b>	<b>Start-up.....</b>	<b>8</b>	7.2	Sensors..... 40
4.1	Setup conditions.....	8	7.3	Interfaces..... 40
4.2	Appliance dimensions.....	9	<b>8</b>	<b>Maintenance..... 41</b>
4.3	Transporting the appliance.....	9	8.1	Maintenance schedule..... 41
4.4	Unpacking the appliance.....	10	8.2	Defrosting the appliance..... 42
4.5	Removing the transport lock.....	10	8.3	Cleaning the appliance..... 42
4.6	Installing the door handle.....	10	<b>9</b>	<b>Customer support..... 44</b>
4.7	Mounting the anti-tipping device.....	10	9.1	Technical data..... 44
4.8	Setting up the appliance.....	11	9.2	Technical malfunction..... 44
4.9	Leveling out the appliance.....	11	9.3	Customer Service..... 45
4.10	Setting up multiple appliances.....	12	9.4	Type plate..... 45
4.11	After setup.....	12	<b>10</b>	<b>Shutting down..... 45</b>
4.12	Disposal of packaging.....	12	<b>11</b>	<b>Disposal..... 46</b>
4.13	Reversing the door opening direction.....	12	11.1	Preparing the appliance for disposal..... 46
4.14	Aligning the door.....	20	11.2	Disposing of the appliance in an environmentally friendly manner..... 46
4.15	Connecting the appliance.....	21	<b>12</b>	<b>Additional information..... 46</b>
4.16	Switching on the appliance (first use).....	21	<b>13</b>	<b>Quick Start Guide for everyday use..... 47</b>
<b>5</b>	<b>Storage.....</b>	<b>22</b>	<p>Congratulations on the purchase of your new appliance. With this purchase, you have chosen all the advantages of the latest refrigeration technology, guaranteeing you a high-quality appliance with a long life span and high operating safety.</p> <p>The equipment of your appliance gives you the highest level of day-to-day ease of operation.</p> <p>Together we are making an active contribution to the conservation of our environment by purchasing this appliance which is manufactured in an environmentally friendly process with the use of recyclable materials.</p> <p>We hope you enjoy your new appliance.</p> <p>The manufacturer is constantly working to improve all types and models. Therefore, please be aware that we reserve the right to make changes to the shape, equipment and technology.</p>	
5.1	Information regarding storing items.....	22		
<b>6</b>	<b>Use.....</b>	<b>22</b>		
6.1	Control and display elements.....	22		
6.1.1	Status display.....	22		
6.1.2	Display symbols.....	23		
6.1.3	Acoustic signals.....	23		
6.2	Appliance functions.....	23		
6.2.1	Notes on the appliance functions.....	23		
6.2.2	Switching appliance on and off ..... 23	23		
6.2.3	Temperature ..... 24	24		
6.2.4	Temperature recording ..... 24	24		
6.2.5	Settings menu access protection ..... 25	25		
6.2.6	Access codes.....	26		
6.2.7	Maintenance interval reminder ..... 27	27		
6.2.8	Language ..... 27	27		
6.2.9	Temperature unit ..... 27	27		
6.2.10	Display Brightness ..... 28	28		
6.2.11	Alarm Sound.....	28		
6.2.12	Key Sound.....	28		
6.2.13	WiFi connection ..... 29	29		
6.2.14	LAN connection ..... 30	30		
6.2.15	Appliance information ..... 31	31		
6.2.16	Operating hours ..... 31	31		
6.2.17	Software ..... 31	31		
6.2.18	Defrosting ..... 31	31		
6.2.19	Sensor calibration ..... 32	32		

Symbol	Explanation
	<b>Read instructions</b> Please read the information in these instructions carefully to understand all of the benefits of your new appliance.

Symbol	Explanation
	<b>Additional information online</b> The digital manual with supplemental information can be found online by scanning the QR code on the front page of this manual or by entering the service number at <a href="http://home.liebherr.com/fridge-manuals">home.liebherr.com/fridge-manuals</a> .
	<b>Check appliance</b> Check all parts for transport damage. If you have any complaints, please contact your agent or customer service.
	<b>Differences</b> These instructions apply to a range of models, so there may be differences. Sections that apply to certain models only are indicated by an asterisk (*).
	<b>Instructions and results</b> Instructions are marked with a ▶. Results are marked with a ▷.
	<b>Videos</b> Videos about the appliances are available on the YouTube channel of Liebherr-Hausgeräte.

These operating instructions apply to:

- SRFfg 3501
- SRFfg 5501

## 1 The appliance at a glance

### 1.1 Included in delivery

Check all parts for transport damage. If you have any issues, please contact your dealer or Customer Service. (see 9.3 Customer Service)

The delivery contains the following parts:

- Freestanding appliance
- Equipment \*
- Installation materials \*
- Operating instructions
- Warranty documents
- Quality certificate \*
- Power cable
- Wall fastening kit

### 1.2 Overview of appliance and equipment

SRFfg 3501  
SRFfg 5501

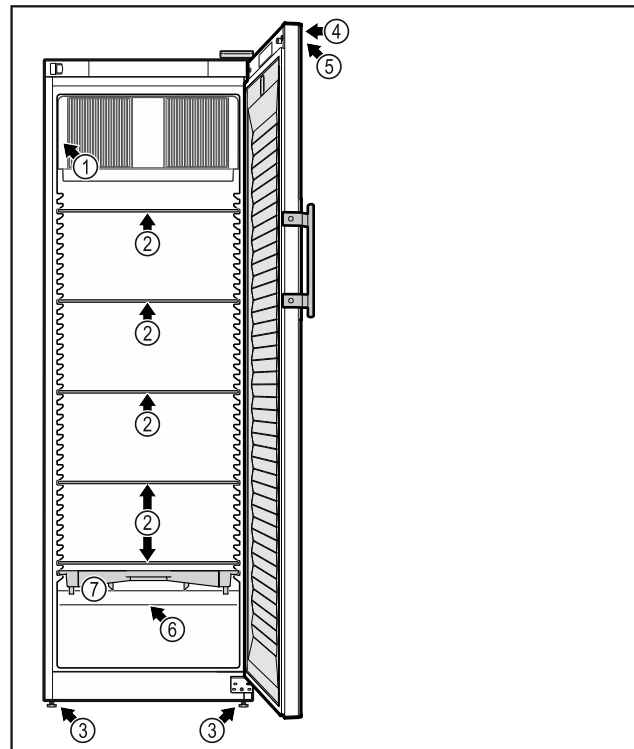

Fig. 1 Example illustration

#### Equipment

- |                     |  |
|---------------------|--|
| (1) Type plate      | (5) Control elements and temperature display |
| (2) Glass shelf     | (6) Safety thermostat sensor                 |
| (3) Adjustable feet | (7) Defrost water collection tray            |
| (4) Lock            |  |

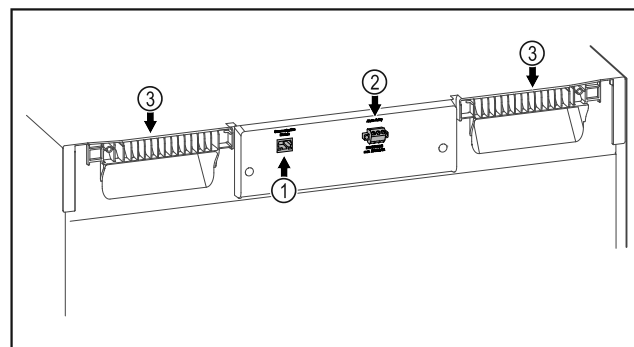

Fig. 2 Example illustration of the rear

#### Equipment

- |                                 |                  |
|---------------------------------|------------------|
| (1) LAN/WiFi interface *        | (3) Carrying aid |
| (2) Potential-free alarm output |                  |

### 1.3 Special features

#### Note

Accessories are available from the Liebherr Service Center. The address for your respective country can be found on the back of the instructions.

# The appliance at a glance

## SmartModule

The appliance can be equipped with a SmartModule. This is a WiFi and LAN interface for the connection between the appliance and an external documentation and alarm system such as Liebherr SmartMonitoring.

Liebherr SmartMonitoring Dashboard is not available in all countries. Check for availability via the QR code (see 6.2.13 WiFi connection ) and entering your model.

## Retrofitting drawers

Temperature qualification is required when retrofitting drawer systems in Liebherr refrigerators/freezers where these are used for temperature-sensitive materials such as chilled drugs and refrigerated products which are subject to specific standards requirements. Retrofitting drawers in Liebherr refrigerators/freezers can result in the goods stored becoming spoiled or damaged. The retrofitting must therefore be completed exclusively by authorized service providers from the manufacturer of the refrigerator/freezer.

## 1.4 Range of appliance use

### Intended use

This laboratory refrigerator, with an interior free of ignition sources, is suitable for professional storage of highly flammable products in closed containers, at temperatures between 3 °C (38 °F) and 16 °C (60 °F).

### Explosion-proof interior

The values relating to your appliance are printed on the sticker on the appliance door.



Fig. 3

The interior, which is free from sources of ignition, is used for storing flammable substances in closed containers and meets the requirements for **Class I, Division 2** for storage of flammable materials equivalent of Gas Group B. Complies with the applicable requirements of NFPA 45 and NFPA 99. This is not an explosionproof refrigerator.

Observe the following specifications for storage:

- Pay attention to the corresponding zones, explosion groups and temperature classes for the substances to be stored.
- Observe the spontaneous combustion temperature. The spontaneous combustion temperature of the substances to be stored must be higher than temperature class T6 (> 85 °C (185 °F)).
- Refer to the corresponding safety data sheet for the storage conditions of the products to be stored.
- Observe the maximum storage quantities.
- Observe the applicable directives if you want to store different substances together.
- If unsure, contact a safety expert or the supplier if the relative material is suitable for storage.
- Observe local and specific directives and requirements to ensure the safety of personnel and the facility.

Storage of temperature-sensitive substances requires the use of an independent, permanently monitored alarm system. This alarm system must be designed such that a responsible person can record every alarm condition to be able to take suitable measures.

### Foreseeable incorrect use

Do not use the appliance for the following applications:

- Storage and cooling of:
  - Chemically unstable substances
  - Blood, plasma or other body fluids for the purpose of infusion, application or introduction in the human body.
- Use in potentially explosive atmospheres.
- Use outdoors or in areas exposed to dampness and splashing water.
- Used in a residential spaces because suitable protection of radio reception cannot be ensured in these environments.\*

Any misuse of the appliance may result in damage to or spoilage of stored goods.

### Climate classes

The climate class for your appliance is printed on the identification plate.

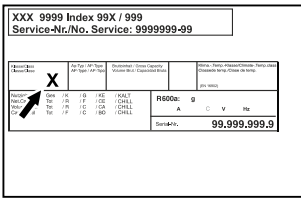

Fig. 4 Type plate

**(X)** This climate class indicates the environmental conditions in which the appliance can be operated safely.

Climate class (X)	max. room temperature	max. rel. humidity
7	35 °C (95 °F)	75%

### Note

The minimum permitted room temperature at the setup location is 10 °C (50 °F).

Slight condensation may form on the glass door on the side walls if the boundary conditions are exceeded.

## 1.5 Sound emission of the appliance

The A-weighted emission sound pressure level during operation of the appliance is below 70 dB(A) (sound power rel.1 pW).

## 1.6 Conformity

The refrigerant circuit has been tested for leaks. The appliance complies with the relevant safety regulations as well as the corresponding directives.

## 2 General safety instructions

Please keep these operating instructions in a safe place so you can refer back to them at any time.

If you pass the appliance on, please hand these operating instructions to the new owner. Read and follow these instructions. They contain safety information which is important for safe and problem-free installation and operation. Always read and follow the safety information.

### Dangers for the user:

- This appliance may only be used by specialist and laboratory personnel who have been trained for this purpose and are

familiar with all the safety measures for work in a laboratory. Children and persons with impaired physical, sensory or mental abilities or with a lack of experience and knowledge may not commission or operate this appliance.

- **IMPORTANT:** The power plug must be easily accessible so that the appliance can be disconnected from the mains quickly in an emergency. It must not be behind the back of the appliance.
- Always hold the plug of the cable when disconnecting the appliance from the power supply. Do not pull on the cable.
- Remove the plug or disconnect via the fuse if there is a malfunction.
- **WARNING:** Do not damage the power cable. Do not operate the appliance with a faulty power cable. If the supply cord is damaged, it must be replaced by the manufacturer, its service agent or similarly qualified persons in order to avoid a hazard. For Plug and Play connection cables, the exchange may be carried out by the customer.
- **WARNING:** Multi-sockets/power distributors and other electronic appliances (such as halogen transformers) may not be placed and operated behind appliances.
- **WARNING:** Do not block the ventilation openings in the appliance housing or in the installation housing.
- **WARNING:** Dust deposits on fan blades! Risk of sparks due to friction! Do not store dusty objects in the appliance. The ventilation slots of the recirculation fan must be cleaned each month using a vacuum cleaner.
- Repairs and work on the appliance may only be carried out by Customer Service or other specifically trained qualified personnel.
- Always follow the instructions when assembling, connecting and disposing of the appliance.

### Risk of fire:

- The refrigerant contained within the appliance (specifications on the type plate) is environmentally friendly, but flammable. Leaking refrigerant can ignite.
  - **WARNING:** Do not damage the refrigerant circuit.

## General safety instructions

- Do not handle ignition sources inside the appliance.
- **WARNING:** Do not use electrical appliances inside the food storage compartments of the appliance, unless they are of the type recommended by the manufacturer.
- If refrigerant leaks: Remove naked flames or ignition sources located near the area of the leak. Ventilate the room well. Contact Customer Service.
- Do not operate the appliance near explosive gases.
- Do not store or use gasoline or other flammable gases and liquids near the appliance.
- Keep lit candles, lamps and other objects with naked flames away from the appliance so they do not cause a fire.

### Risk of falling or toppling over:

- **WARNING:** To avoid a hazard due to instability of the appliance, it must be fixed in accordance with the instructions.
- Do not stand on the base, drawers, doors etc. or use them as improper supports.

### Danger of frostbite, feeling of numbness and pain:

- Avoid prolonged skin contact with cold surfaces or chilled/frozen food or take protective measures, e.g. wear gloves.

### Risk of injury and damage:

- **WARNING:** Do not use mechanical devices or other means to accelerate the defrosting process, other than those recommended by the manufacturer.
- **WARNING:** Risk of injury due to electric shock! There are live electrical parts under the cover.
- **NOTICE:** The appliance must only be operated using original manufacturer accessories or accessories from other providers approved by the manufacturer. The user bears the risk of using accessories which are not approved.

### Risk of crushing:

- Do not reach into the hinge when opening and closing the door. Fingers may get trapped.

### California Proposition 65:

- **WARNING:** This product can expose you to chemicals including Diisononyl Phthalate (DINP), which is known to the State of California to cause cancer, and Diisodecyl Phthalate (DIDP), which is known to the State of California to cause birth defects or other reproductive harm. For more information, go to [www.P65Warnings.ca.gov](http://www.P65Warnings.ca.gov)

### Specialist personnel qualifications:

The appliance may only be installed, tested, maintained, and commissioned by specialist personnel who are familiar with the installation, commissioning, and operation of the appliance.

Specialist personnel are persons who, on account of their specialist training, knowledge and experience as well as their knowledge of the relevant standards, are able to assess and perform the work assigned to them and identify potential hazards. They must have training, instruction, and authorization to work on the appliance.

### Symbols on the device:



The symbol may be located on the compressor. It refers to the oil in the compressor and refers to the following danger: **Can be fatal if swallowed or inhaled.** This notice only applies for recycling. There is no danger during normal operation.



**WARNING:** Risk of fire / flammable materials. The symbol is located on the compressor and indicates the danger from flammable materials. Do not remove the label.

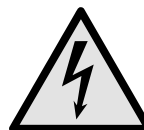



The symbol is located on the back of the appliance near the alarm relay and indicates the following danger: **Electric shock!** Even if an appliance is disconnected from the mains there may still be extraneous voltage. Do not remove the label.



This label or a similar one may be located on the rear of the appliance. This label indicates that there are vacuum insulation panels (VIP) or perlite panels in the door and/or housing. This notice only applies for recycling. Do not remove the label.

Observe the warning messages and other detailed information in the other sections:



	<b>DANGER</b>	Indicates an immediately hazardous situation, which if not avoided, will result in death or serious injury.
	<b>WARNING</b>	Indicates a hazardous situation, which if not avoided, could result in death or serious injury.
	<b>CAUTION</b>	Indicates a hazardous situation, which if not avoided, could result in minor or moderate injury.
	<b>NOTICE</b>	Indicates a hazardous situation, which if not avoided, could result in damage to property.
	<b>Note</b>	Indicates useful advice and tips.







## 3 Functionality of the Touch display

You operate your appliance using the Touch display. You select appliance functions in the Touch display (hereafter referred to as display) by tapping them. If you do not perform any action on the display for 10 seconds, the display either jumps back to the higher-level menu or directly to the status display.

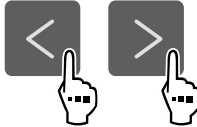
### 3.1 Navigation and symbol explanation

In the illustrations, different symbols are used to navigate the display. The following table describes these symbols.

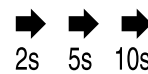
Symbol	Description
	<b>Press the Next navigation arrow:</b> Navigates to the next option in the menu.
	<b>Press the Back navigation arrow:</b> Jumps back one option in the menu.
	<b>Press and hold the Back navigation arrow for 3 seconds:</b> Jumps back to the status display in the main menu or from the Settings menu.

Symbol	Description
	<b>Press the navigation arrow several times in succession:</b> Navigates in the menu to the desired function.
	<b>Press the Confirm symbol:</b> Activates/deactivates function. Opens submenu.
	<b>Press the Confirm symbol together with the back icon:</b> Jumps back one menu level.
	<b>Arrow with clock:</b> It takes more than 10 seconds for the following message to appear in the display.
	<b>Arrow with a time indication:</b> It takes the specified amount of time until the following message appears in the display.
	<b>“Open Settings menu” symbol:</b> Navigates to the Settings menu and opens the settings menu. If necessary: Navigate to the desired function in the Settings menu. (see 3.2.1 Opening the Settings menu)
	<b>“Open Advanced menu” symbol:</b> Navigates to the Advanced menu and opens the advanced menu. If necessary: Navigate to the desired function in the Advanced menu. (see 3.2.2 Opening the Advanced menu)
No action for 10 seconds	If you do not perform any action on the display for 10 seconds, the display either jumps back to the higher-level menu or directly to the status display.



# Start-up

Symbol	Description
Opening door and closing it again	If you open the door and immediately close it again, the display jumps directly back to the status display.

Note: Illustrations of the display are shown in the English version.

## 3.2 Menus

The appliance functions can be found in various menus.

Menu	Description
Main menu	When you switch the appliance on, you are automatically in the main menu. From here you can navigate to the most important appliance functions, to the Settings menu and to the Advanced menu.
 Settings menu	The Settings menu contains additional appliance functions for setting up your appliance. (see 3.2.1 Opening the Settings menu)
 Advanced menu	The advanced menu contains special appliance functions for setting up your appliance. Access to the Advanced menu is protected by the numerical code <b>151</b> . (see 3.2.2 Opening the Advanced menu)

### 3.2.1 Opening the Settings menu

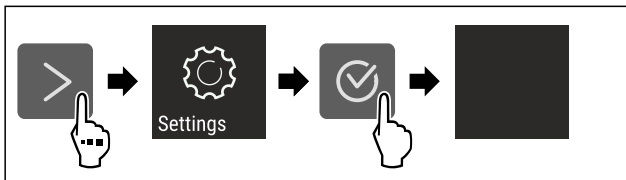

Fig. 5 Example illustration

- ▶ Carry out action steps according to the illustration.
- ▷ Settings menu is open.
- ▶ If necessary: Navigate to the desired function.

### 3.2.2 Opening the Advanced menu

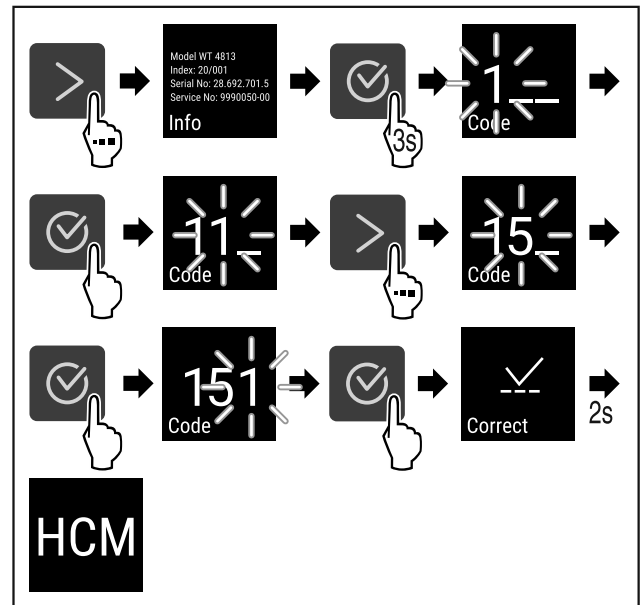

Fig. 6 Access with numerical code **151**

- ▶ Carry out action steps according to the illustration.
- ▷ Expanded menu is open.
- ▶ If necessary: Navigate to the desired function.

## 3.3 Sleep mode

If you do not touch the display for 1 minute, the display switches to sleep mode. In sleep mode, the display brightness is dimmed.

### 3.3.1 Ending sleep mode

- ▶ Press any navigation key.
- ▷ Sleep mode is ended.

## 4 Start-up

### 4.1 Setup conditions



#### WARNING

Risk of fire due to moisture!

If live parts or the power cord get wet, this can cause a short circuit.

- ▶ The appliance is designed for use in enclosed spaces. Do not operate the appliance in open space or in damp areas or where there is spray.



### 4.1.1 Setup location



**WARNING**

Leaking refrigerant and oil!  
 Fire. The refrigerant contained within the appliance is environmentally friendly, but flammable. The oil contained within the appliance is flammable. Escaping refrigerant and oil can ignite if they are of high enough concentration and are exposed to an external heat source.

▶ Do not damage the pipelines of the coolant circuit and the compressor.

- Do not setup the appliance in direct sunlight, next to an oven, radiator or similar.
- The best place to set up the appliance is a dry and well ventilated room.
- If the appliance is set up in a very humid environment, condensation can form on the outside of the appliance.

Always ensure sufficient airflow and ventilation in the setup location.

- The more refrigerant there is in the appliance, the larger the space it is installed in must be. If the space is too small, any leak may create a flammable mixture of gas and air. For every 8 g (0.28 oz) of refrigerant, the installation space must be at least 1 m<sup>3</sup> (35.5 ft<sup>3</sup>). Specifications on the refrigerant in the appliance can be found on the serial tag plate inside the appliance.
- The floor of the setup location must be horizontal and even.
- The setup location must be able to withstand the weight of the appliance plus the weight when stocked to maximum capacity. (see 9.1 Technical data)
- Use in hazardous areas is not permitted.

### 4.1.2 Electrical connection



**WARNING**

Danger of fire due to incorrect positioning!  
 If the power supply cable or plug touches the back of the appliance, the vibration can damage the power supply cable or the plug resulting in a short circuit.

- ▶ Make sure the power supply cable is not trapped under the appliance when you position the appliance.
- ▶ Install the appliance so that it does not touch any plugs or power cables.
- ▶ Do not connect any appliances to sockets in the area of the back of the appliance.
- ▶ Do **not** place and operate power strips/power distributors and other electronic devices (such as halogen transformers) at the back of the appliances.

### 4.2 Appliance dimensions

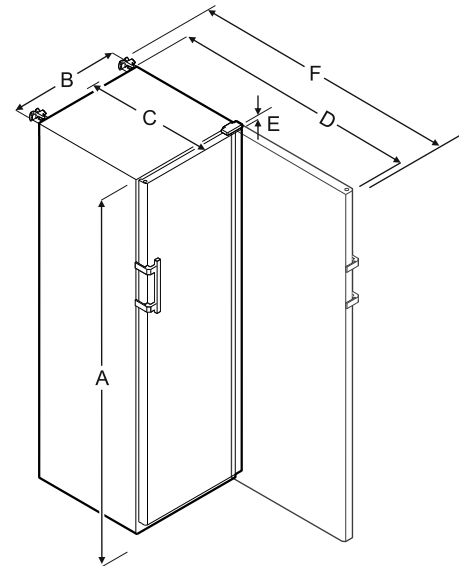

Fig. 7

	SRFfg 3501	SRFfg 5501
A	1684 mm (66 5/16 in)	1684 mm (66 5/16 in)
B	597 mm (23 1/2 in)	747 mm (29 7/16 in)
C	664 mm (26 1/8 in)	779 mm (30 11/16 in)
D	1203 mm (47 3/8 in)	1468 mm (57 13/16 in)
E	23 mm (7/8 in)	23 mm (7/8 in)
F	1241 mm (48 7/8 in)	1506 mm (59 5/16 in)

- A = appliance height including feet/castors
- B = appliance width without handle [handle depth = 45 mm (1 6/8 in)]
- C = appliance depth without handle [handle depth = 45 mm (1 6/8 in)]
- D = appliance depth with door open
- E = hinge height
- F = appliance depth with protruding handle and anti-tipping device

### 4.3 Transporting the appliance



**WARNING**

Danger of injury and damage due the equipment falling over!

- ▶ Pay attention to the evenness of the ground and ramps when transporting the equipment.

**Observe the following when transporting the appliance:**

- ▶ Transport the appliance upright.
- ▶ Use two people when transporting the appliance.

**During the first use:**

## Start-up

- ▶ Transport the appliance packaged.

**During appliance transport or at first use (e.g. when moving or cleaning):**

- ▶ Empty the appliance.
- ▶ Secure the door against undesired opening.

### 4.4 Unpacking the appliance

- ▶ Check the appliance and the packaging for transport damage. Contact the supplier immediately if you suspect any damage. Do not connect the appliance to the power supply.
- ▶ Remove all packaging materials from the rear or the side walls of the fridge that may prevent proper installation or prevent air flow and ventilation.

### 4.5 Removing the transport lock

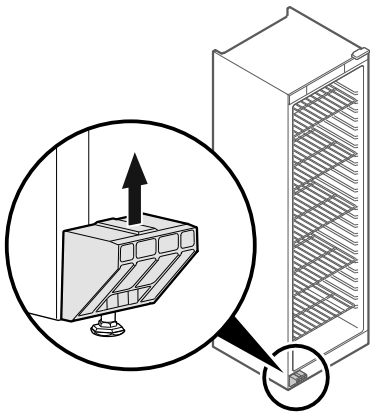

Fig. 8

- ▶ Remove transport lock in upwards direction.
- ▷ Base holder remains on the appliance.

### 4.6 Installing the door handle

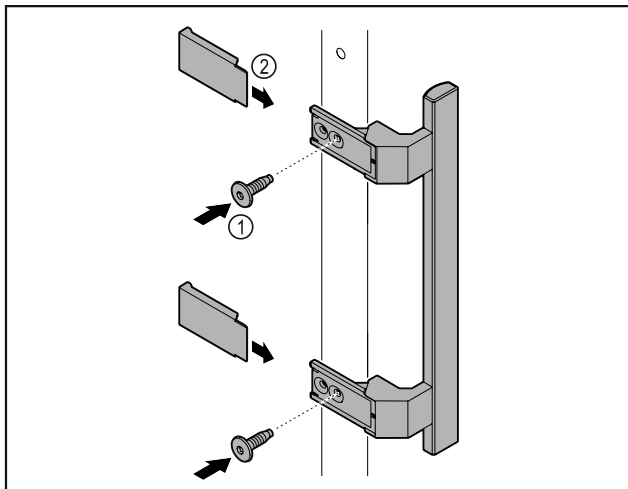

Fig. 9

- ▶ Attach handle from accessory kit to the door using supplied screws Fig. 9 (1).
- ▶ Put on cover Fig. 9 (2).

### 4.7 Mounting the anti-tipping device

Tools

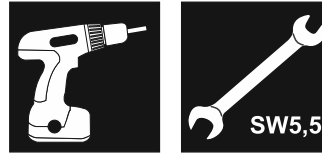

Fig. 10



#### WARNING

Danger of injury and damage due to appliance tipping over!

Danger to life and material damage to appliance. If you remove fully loaded shelves from the appliance, the appliance can tip over.

- ▶ Before you put the appliance into operation: install the anti-tipping device in accordance with the instructions.

Prevent appliance from tipping over.

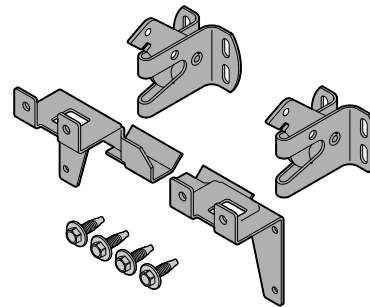

Fig. 11

The tilt protection is enclosed with the appliance. It is comprised of two retaining parts, two securing hooks and four self-tapping screws (4 x 14).

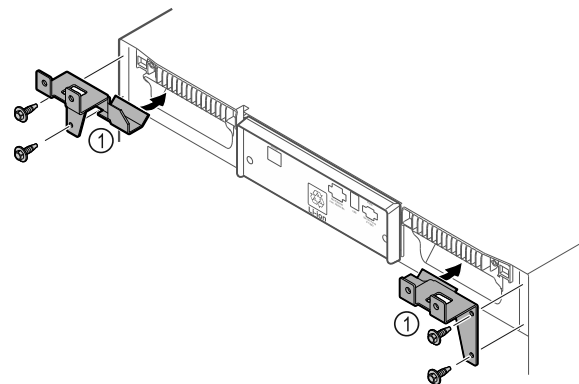

Fig. 12

- ▶ Assemble the retaining parts Fig. 12 (1) with the self-tapping screws on the appliance.
- ▶ Push appliance with retaining parts mounted against the wall.

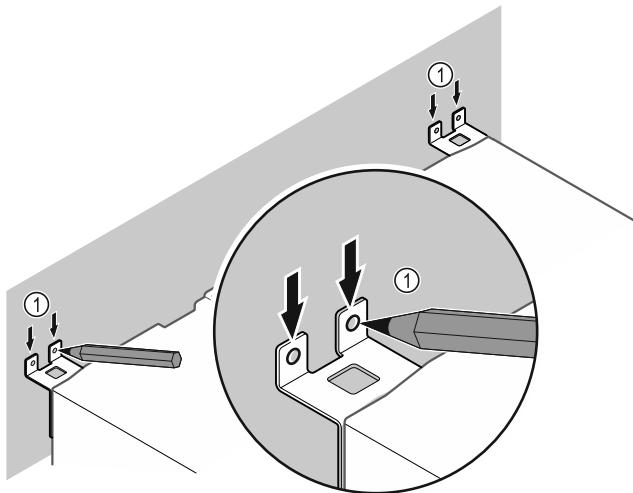

Fig. 13

- ▶ Make markings on the wall Fig. 13 (1).
- ▶ Remove appliance.

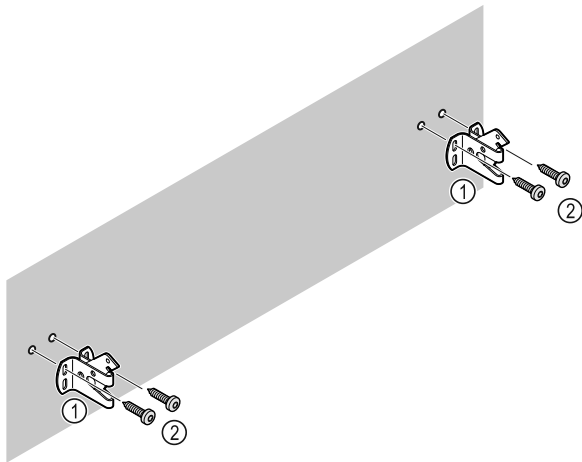

Fig. 14

Use fixing material (e.g. wall anchors) which is appropriate for the nature of the wall (wood, concrete) and sufficient attachment points .

- ▶ Attach retaining hooks.

## 4.8 Setting up the appliance



### CAUTION

Risk of injury and damage.

- ▶ Use 2 people to set up the appliance.



### CAUTION

Risk of injury and damage.

The door can strike against the wall and become damaged as a result. In the case of glass doors, the damaged glass can cause injuries.

- ▶ Protect the door from striking against the wall. Attach a door stopper, e.g. felt stopper, to the wall.

- ▶ Connect all necessary components (e.g. power cable) to the back of the appliance and route to the side.

### Note

Cables can be damaged.

- ▶ Do not crush the cable when pushing the appliance back.

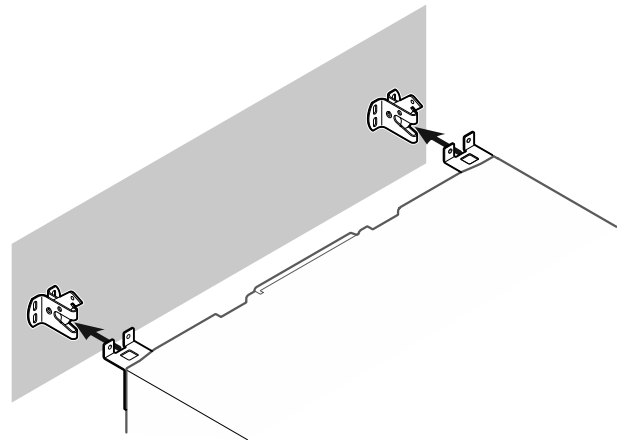

Fig. 15

- ▶ Slide the appliance up against the wall so that the retaining parts latch into the retaining hooks.
- ▷ The appliance is now secured against tipping.
- ▷ It can be released by folding back the retaining hooks.

## 4.9 Leveling out the appliance

### NOTICE

Appliance body can become deformed and door will not close.

- ▶ Align appliance horizontally and vertically.
- ▶ Compensate for uneven floors using adjustable feet.



### WARNING

Incorrect height adjustment of the adjustable foot!

Severe or fatal injuries. Incorrect height adjustment can cause the bottom part of the adjustable foot to come loose and the appliance to tip over.

- ▶ Do not unscrew the adjustable foot too far.

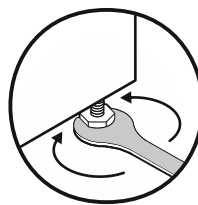

Fig. 16

### Raising appliance:

- ▶ Turn adjustable foot clockwise.

### Lowering appliance:

- ▶ Turn adjustable foot counterclockwise.

# Start-up

## 4.10 Setting up multiple appliances

### NOTICE

Risk of damage due to condensation between the side walls.

- ▶ Do not set up the appliance directly next to another refrigeration appliance.
- ▶ Set up appliances with a space of 3 cm (1.18 in) between appliances.
- ▶ Only set up multiple appliances up to temperatures of 35 °C (95 °F) and 65 % humidity next to one another.
- ▶ At higher levels of humidity, increase the space between appliances.

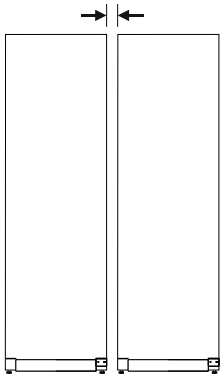

Fig. 17 Side-by-side set up

### Note

A side-by-side kit is available as an accessory via Liebherr Customer Service. (see 9.3 Customer Service)

## 4.11 After setup

- ▶ Peel off the protective films. \*
- ▶ Clean the appliance. (see 8.3 Cleaning the appliance)
- ▶ If necessary: Disinfect the appliance.
- ▶ Keep the invoice so you have the appliance and dealer information available if needed.

## 4.12 Disposal of packaging



### WARNING

Danger of suffocation from packaging materials and films!

- ▶ Do not allow children to play with packaging materials.

The packaging is made from recyclable materials:

- Corrugated card/cardboard
- Parts made of foamed polystyrene
- Films and bags from polyethylene
- Packing bands from polypropylene
- Wood frame nailed together with a polyethylene window\*

- ▶ Take the packaging material to an official collection point.

## 4.13 Reversing the door opening direction

### Tools

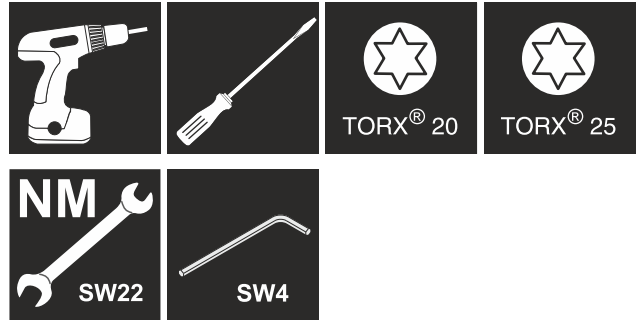

### WARNING

Risk of injury if the door is not reversed correctly!

- ▶ The door may only be reversed by qualified personnel.



### WARNING

Risk of injury and material damage due to heavy door!

- ▶ Only perform the conversion if you can carry a weight of 25 kg (55.11 lb).
- ▶ Always have someone help you carry out the conversion.

### NOTICE

Live parts!

Damage to electrical components.

- ▶ Pull the power plug before changing the door hinges.
- ▶ Open the door.

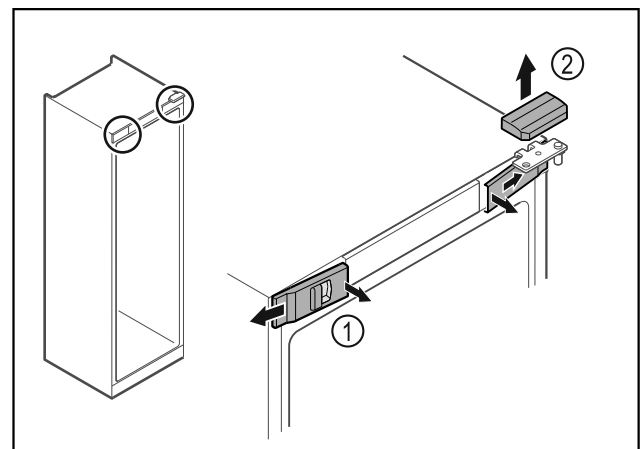

Fig. 18

- ▶ Unlatch the front covers Fig. 18 (1) on the inside and remove them sideways.
- ▶ Lift off the upper cover Fig. 18 (2).

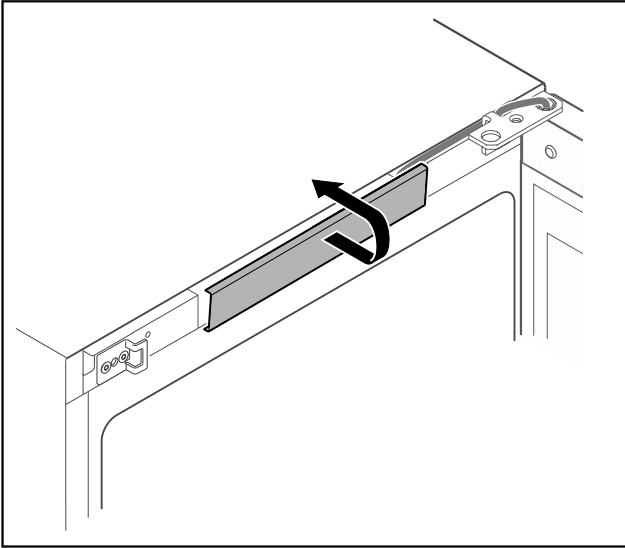

Fig. 19

- ▶ Unlatch the middle cover and remove it.

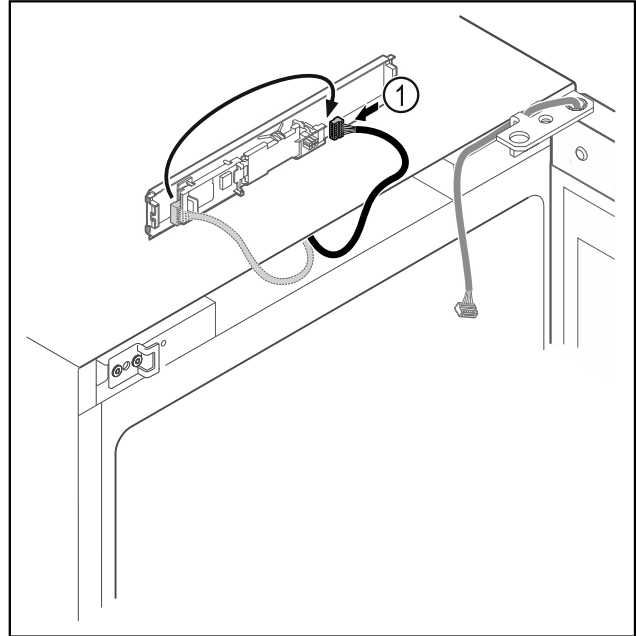

Fig. 21

- ▶ Connect the plug Fig. 21 (1) to the circuit board.

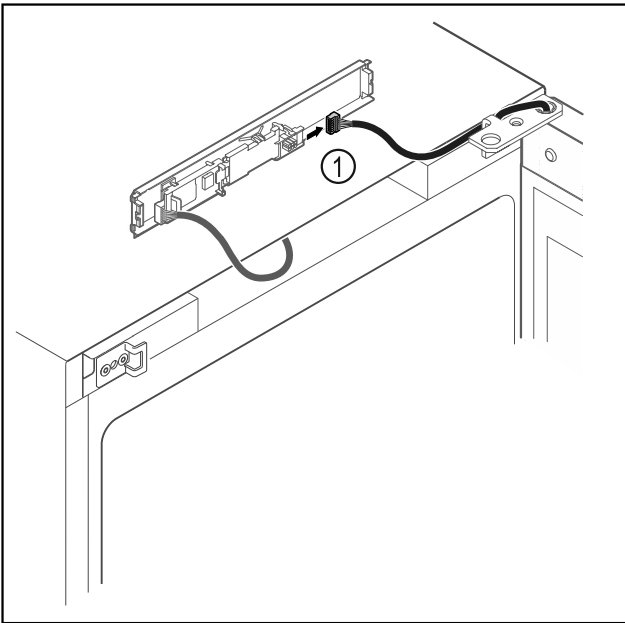

Fig. 20

- ▶ Disconnect the plug Fig. 20 (1) from the circuit board.

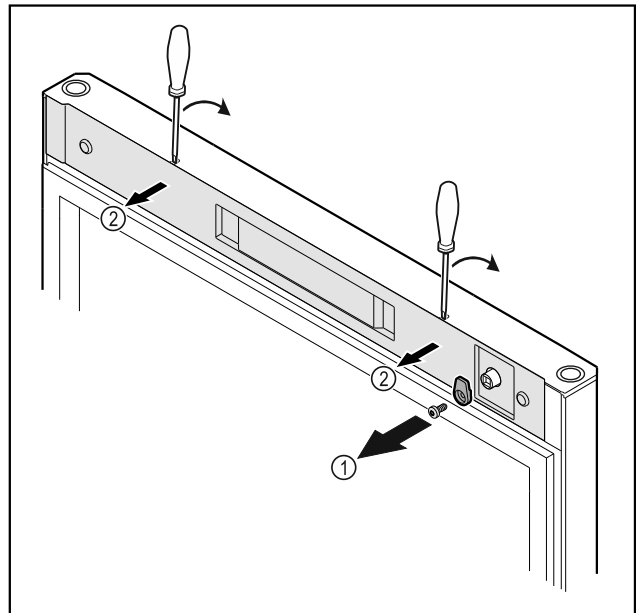

Fig. 22

- ▶ Unscrew the door latch Fig. 22 (1).
- ▶ Unlatch the cover Fig. 22 (2) with a small screwdriver and remove it.

# Start-up

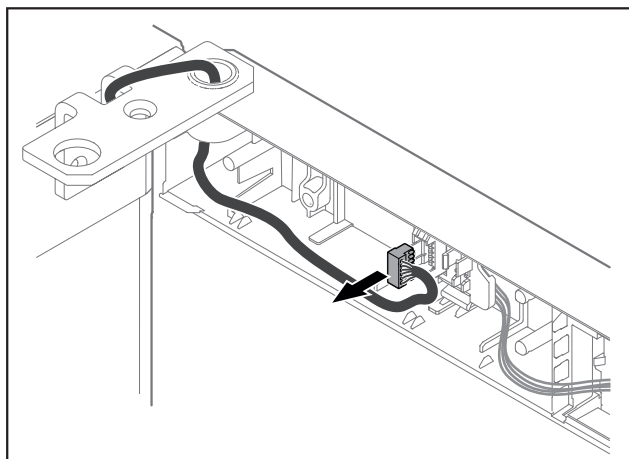

Fig. 23

- ▶ Remove the plug from the plug holder.

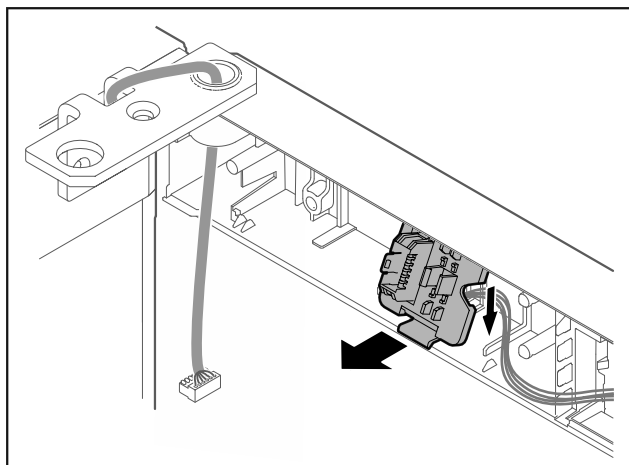

Fig. 24 The installation position of the plug holder can be rotated by 180°.

- ▶ Disengage the plug holder.

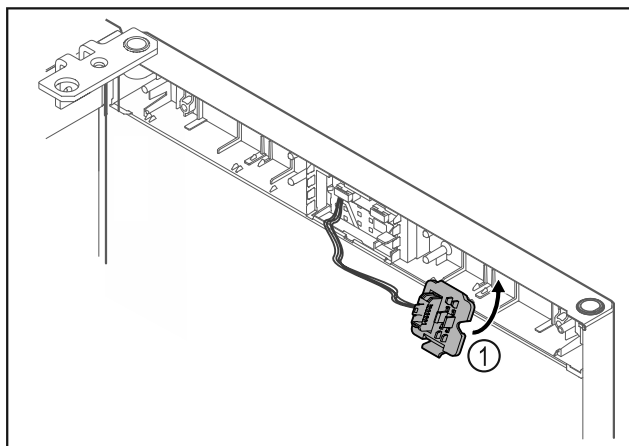

Fig. 25

- ▶ Snap in the plug holder Fig. 25 (1) on the opposite side.

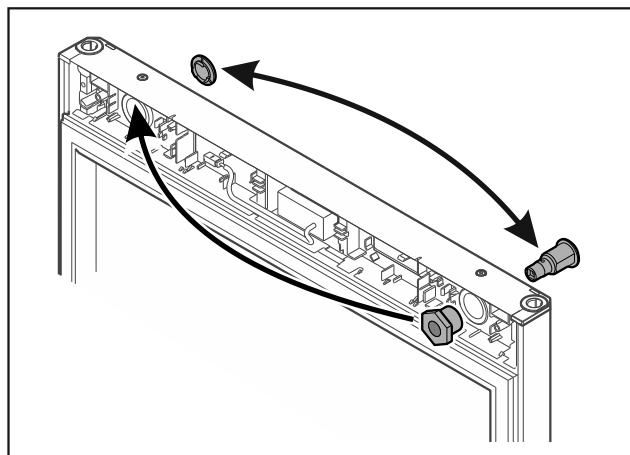

Fig. 26

- ▶ Put the lock and cover on the opposite side.
- or-

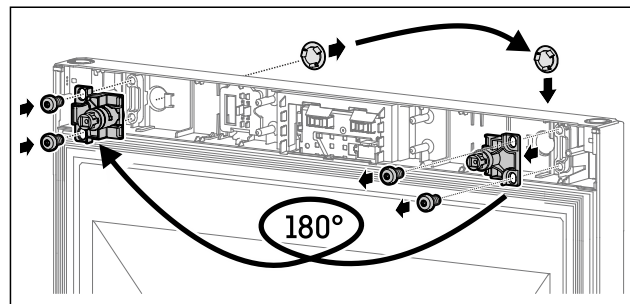

Fig. 27

- ▶ Put the lock and cover on the opposite side.

## NOTICE

Risk of injury if the door tips out!

- ▶ Hold the door.

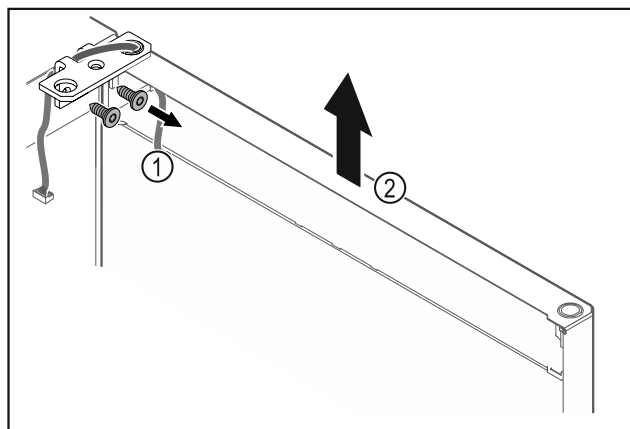

Fig. 28

- ▶ Unscrew the hinge Fig. 28 (1).
- ▶ Lift the door with the hinge straight up by Fig. 28 (2) roughly 200 mm (7.87 in) and take it off.
- ▶ Carefully place the door on a soft surface.

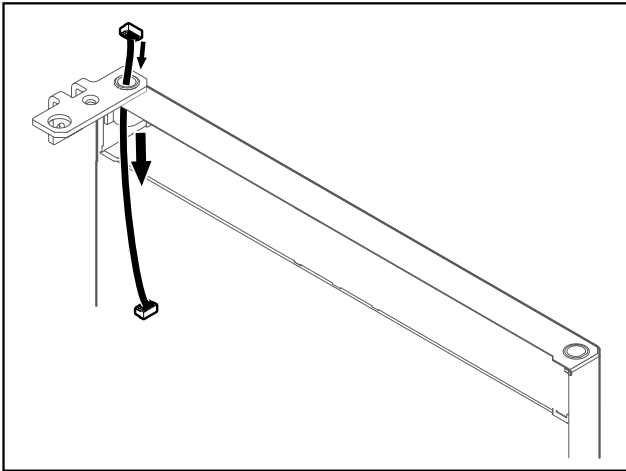

Fig. 29

- Carefully pull out the cable.

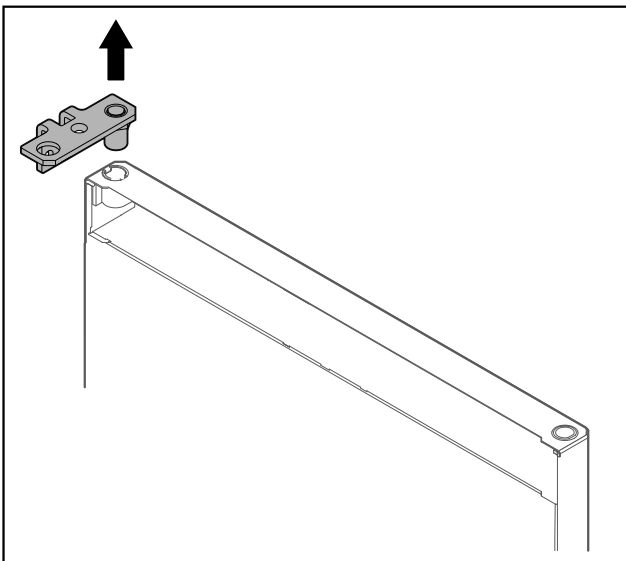

Fig. 30

- Pull out the hinge.

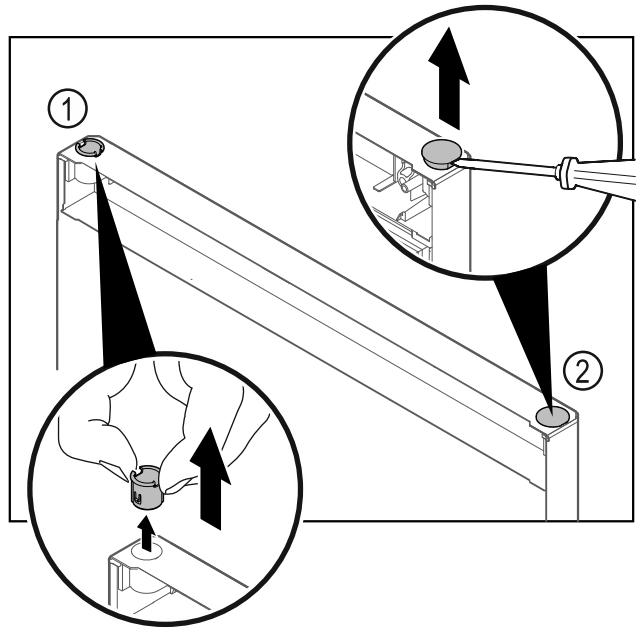

Fig. 31

- Pull out the hinge bushing Fig. 31 (1) with your fingers.
- Carefully lift the cover plug Fig. 31 (2) with a slotted screwdriver and pull it out.

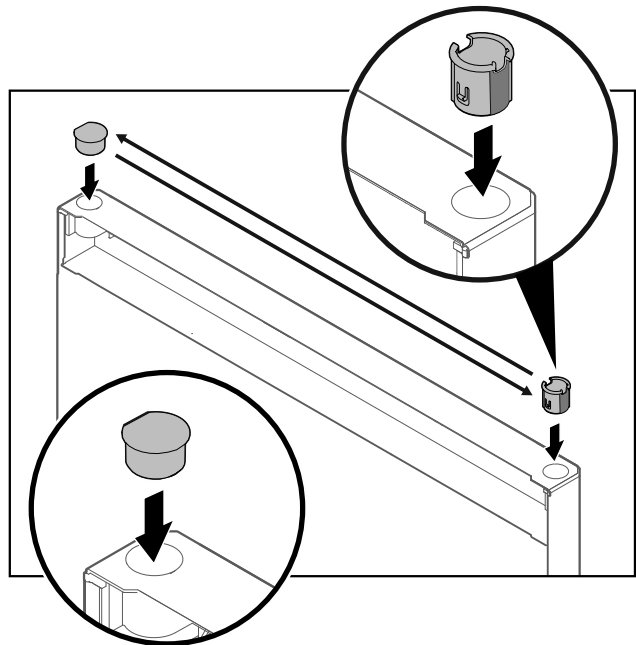

Fig. 32

- Insert hinge bushing and cover plug on the opposite side (the flattened sides face outwards).

## Start-up

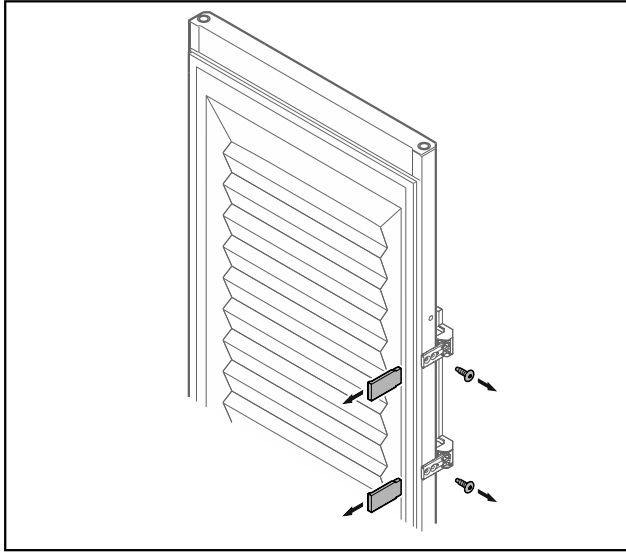

Fig. 33 Insulated door

- ▶ Remove the panels.
- ▶ Unscrew the handle.

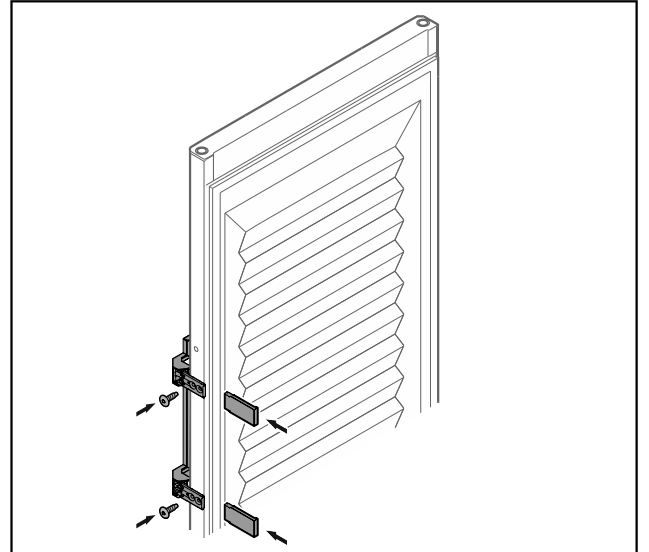

Fig. 35 Insulated door

- ▶ Screw the handle onto the opposite side.
- ▶ Attach the panels.

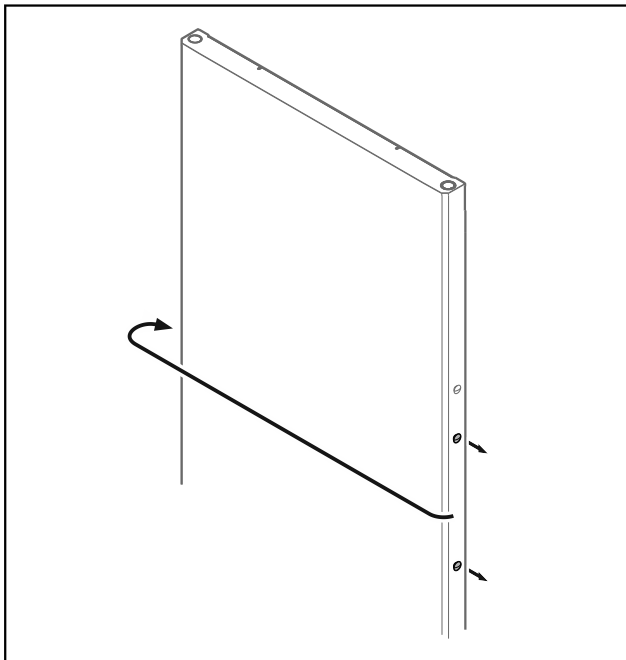

Fig. 34

- ▶ Put the stopper on the opposite side.

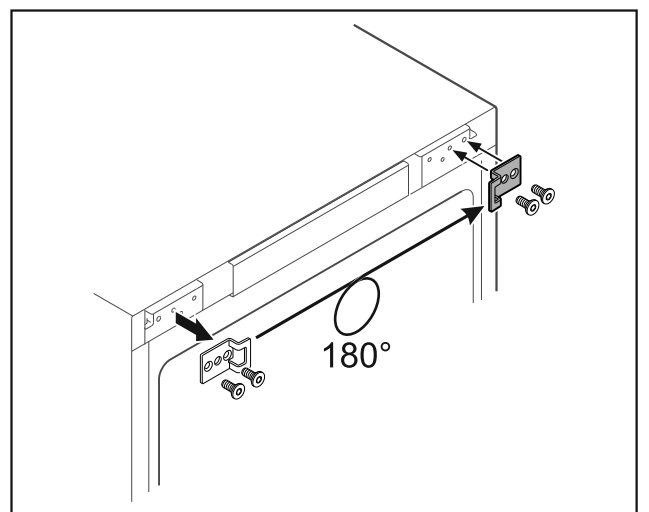

Fig. 36

- ▶ Put the closing bracket on the opposite side.

### Note

The holes are pre-marked and must be pierced with the self-tapping screws.



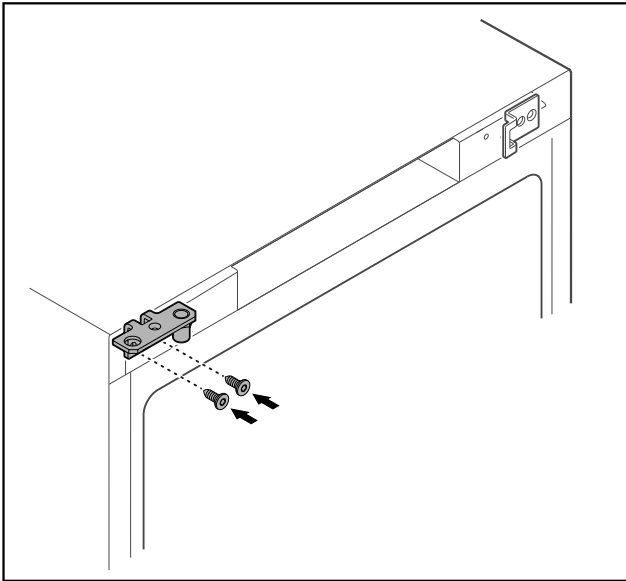

Fig. 37

- ▶ Move the hinge to the opposite side.



## WARNING

Risk of injury and material damage if the door tips out!

- ▶ Tighten the bearing pins to the specified torque.

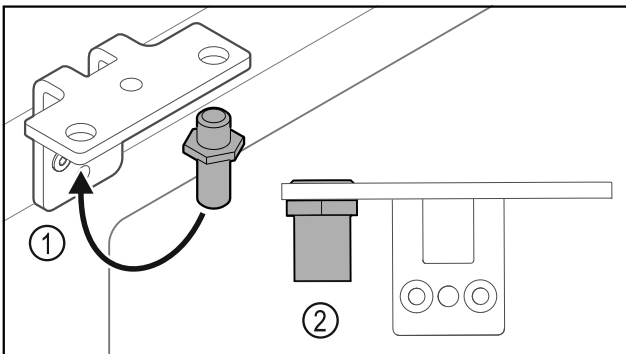

Fig. 38

- ▶ Put the pin back into the hinge Fig. 38 (1).
- ▶ Tighten the pin Fig. 38 (2) to a **torque of 12 Nm (9 ft-lb)**.
- ▶ Unscrew the hinge again.

## NOTICE

Risk of injury due to tensioned spring!

- ▶ Do not disassemble the door closing system Fig. 39 (1).

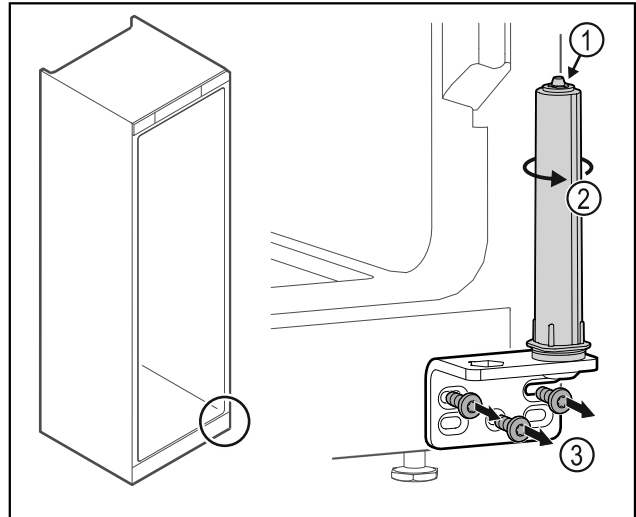

Fig. 39

- ▶ Turn the closing system Fig. 39 (2) until it clicks.
- ▶ The tension of the closing system is released.
- ▶ Unscrew the hinge Fig. 39 (3).

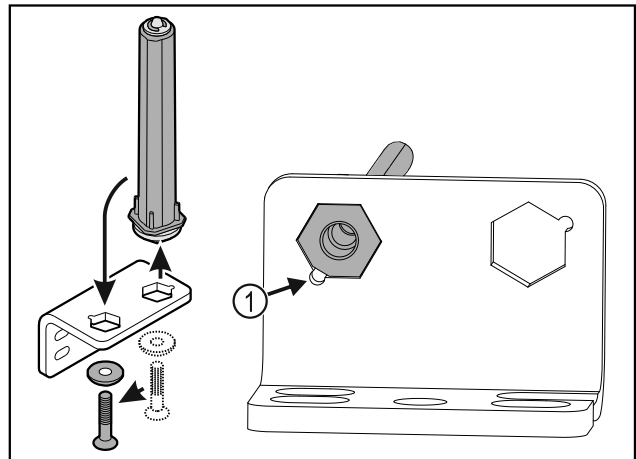

Fig. 40

- ▶ Put the door closing system in the hinge.
- ▶ Make sure the pin chamfer Fig. 40 (1) faces the round hole when you put it in.

-or-

## Note

Incorrect alignment of the height adjustment washers. Nuts no longer have sufficient hold.

- ▶ The washer must lock into the underside of the closing system.

# Start-up

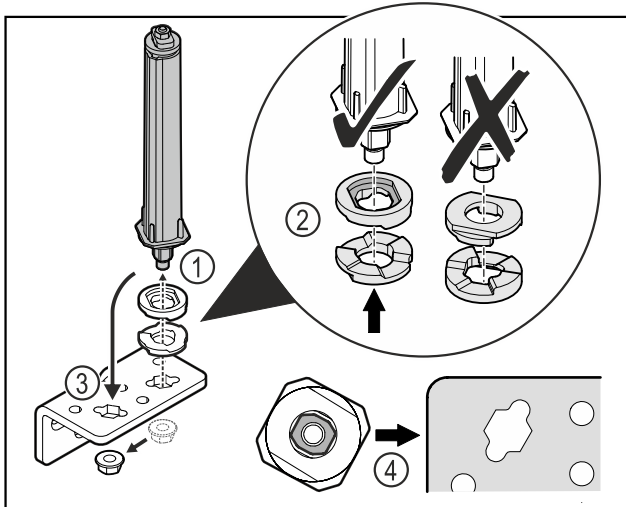

Fig. 41

- ▶ Loosen the nut and remove the door closing system Fig. 41 (1).
- ▶ Observe the correct alignment of the height adjustment washers Fig. 41 (2).
- ▶ Put the door closing system in the hinge fix in place with the nut Fig. 41 (3).
- ▶ Observe the correct alignment of the door closing system when doing so Fig. 41 (4).

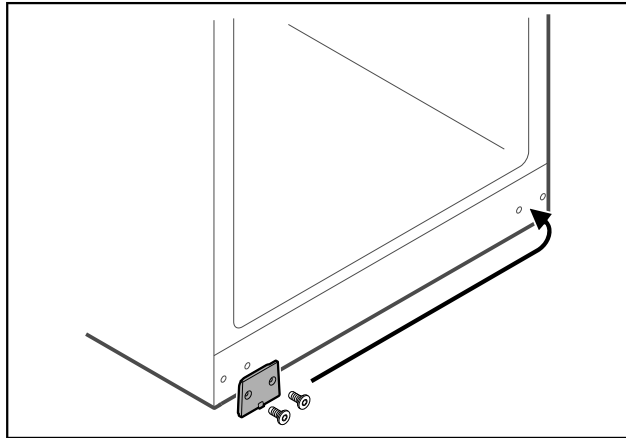

Fig. 42

- ▶ Put the cover plate on the opposite side.

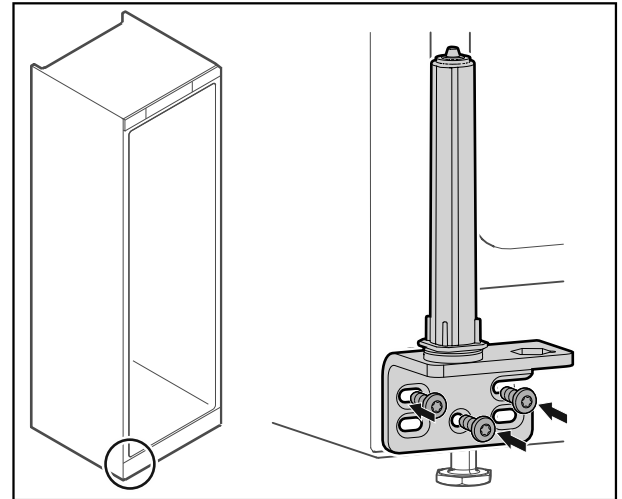

Fig. 43

- ▶ Screw the hinge onto the opposite side.

### Note

Correct alignment and tension are important for the closing system to work properly.

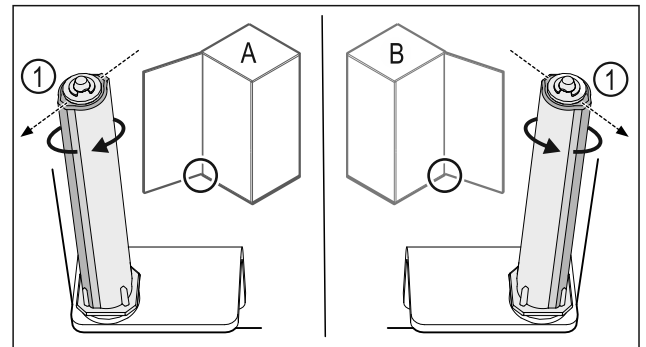

Fig. 44 Left-hinged (A) / Right-hinged (B)

- ▶ Turn the closing system against the resistance until the bar of the closing system Fig. 44 (1) points outwards.
- ▷ The closing system automatically stays in this position.
- ▷ The closing system is now aligned and pretensioned.

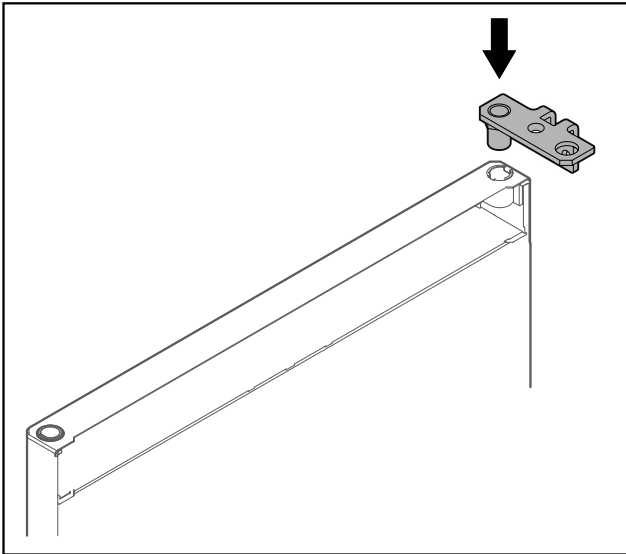

Fig. 45

- ▶ Put the hinge into the door.

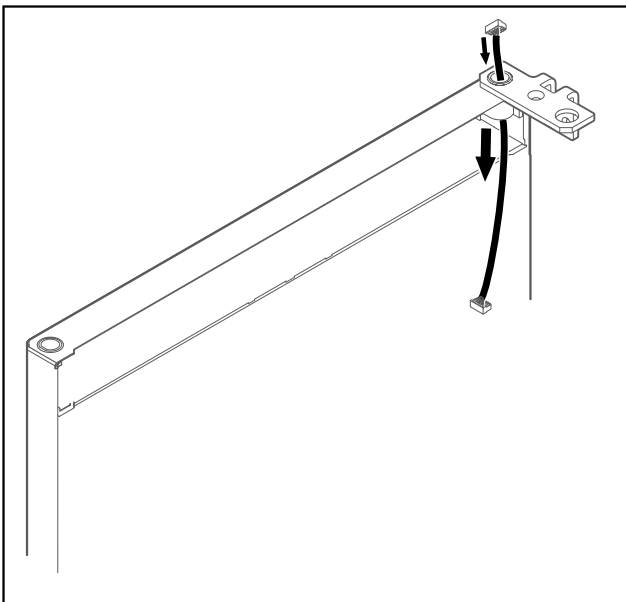

Fig. 46

- ▶ Carefully push the cable through.

**NOTICE**

- Risk of injury if the door tips out!
- ▶ Hold the door.

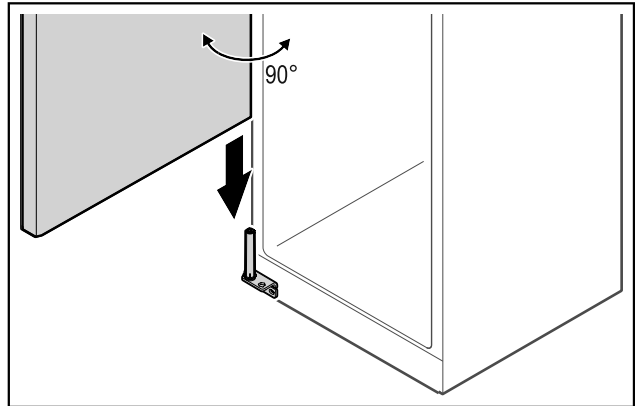

Fig. 47

- ▶ Together with a second person, lift the door from the ground.
- ▶ Carefully put the door on the closing system with the door opened at a 90° angle.

**NOTICE**

Material damage due to incorrect mounting!

- ▶ Do not pinch the cable when mounting the hinge.

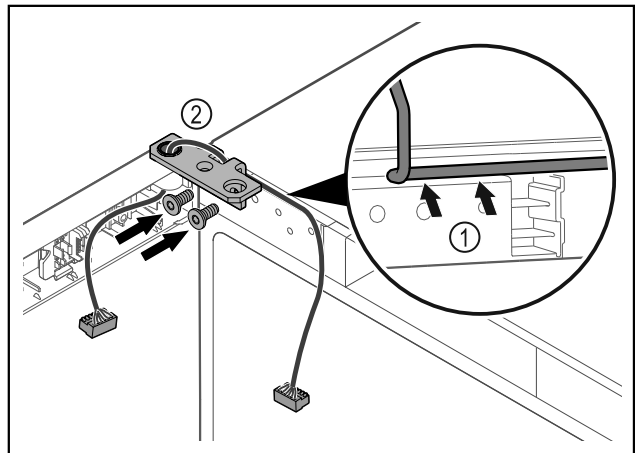

Fig. 48

- ▶ Feed the cable through the recess in the hinge and lay it carefully Fig. 48 (1).
- ▶ Screw on the hinge Fig. 48 (2).

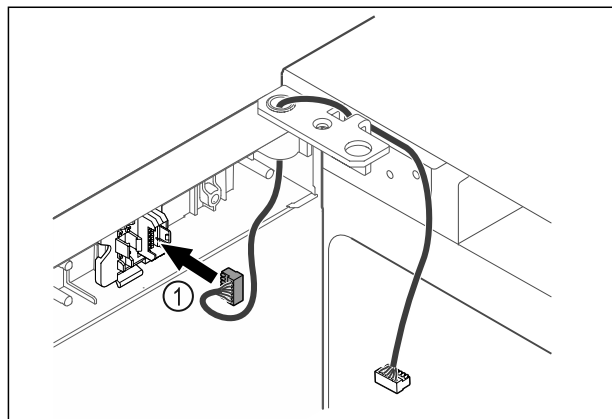
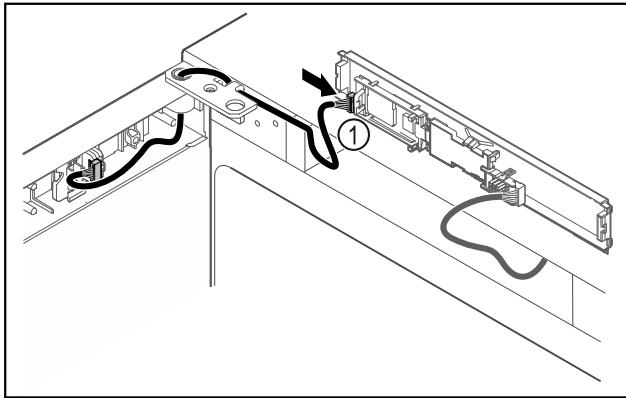

Fig. 49

## Start-up

- ▶ Put the plug *Fig. 49 (1)* in the plug holder.



*Fig. 50*

- ▶ Connect the plug *Fig. 50 (1)* to the circuit board.

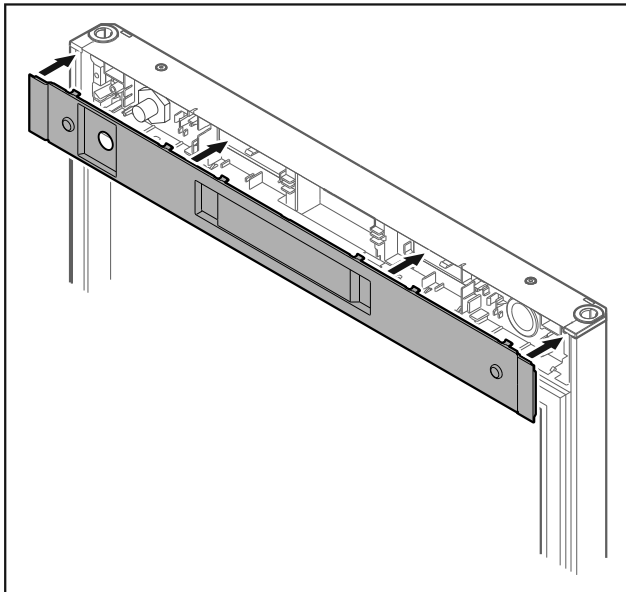

*Fig. 51*

- ▶ Set the cover back in place.

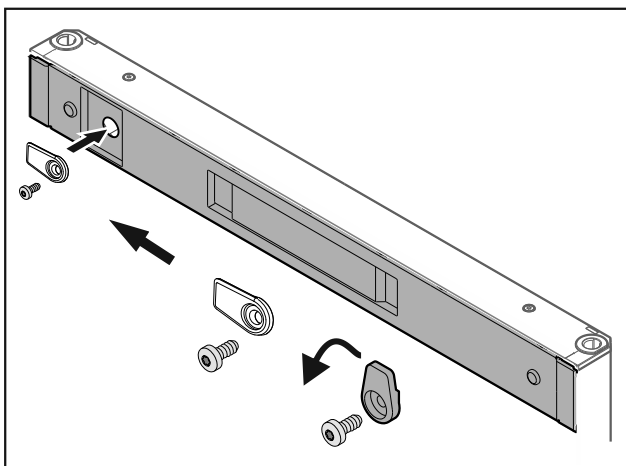

*Fig. 52*

- ▶ Screw on the door latch.

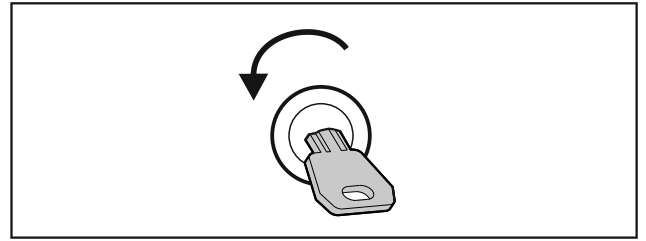

*Fig. 53*

- ▶ Open the door.

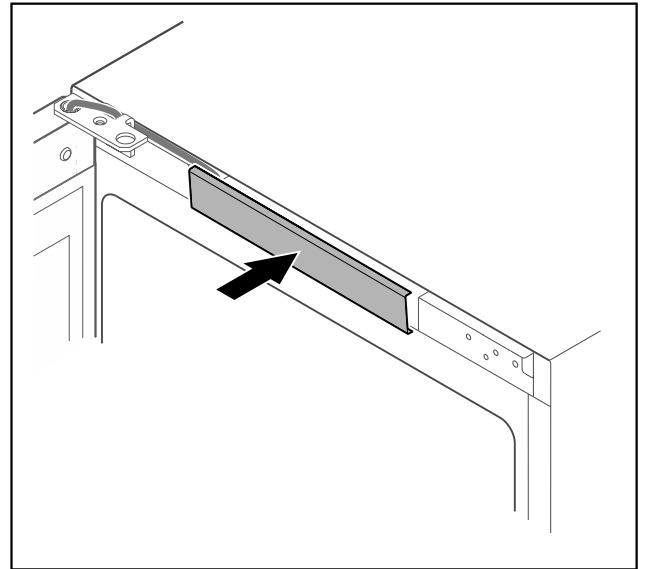

*Fig. 54*

- ▶ Snap in the middle cover.

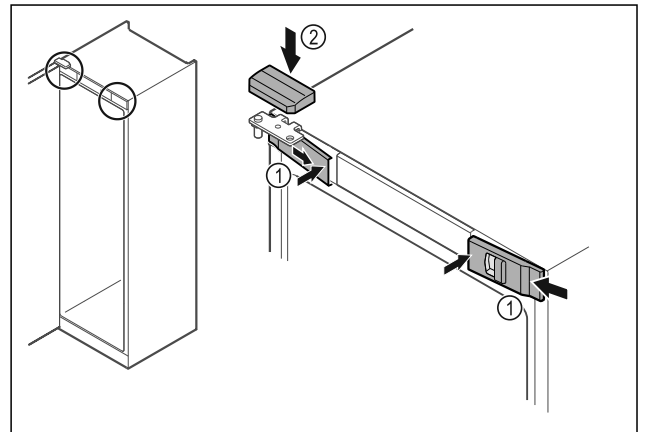

*Fig. 55*

- ▶ Hook in the front covers *Fig. 55 (1)* on the side and snap them into place on the inside.
- ▶ Snap on the top cover *Fig. 55 (2)* from above.
- ▶ Close the door.
- ▷ The door has now been reversed.

### 4.14 Aligning the door

If the door is not straight, you can adjust it on the lower hinge.

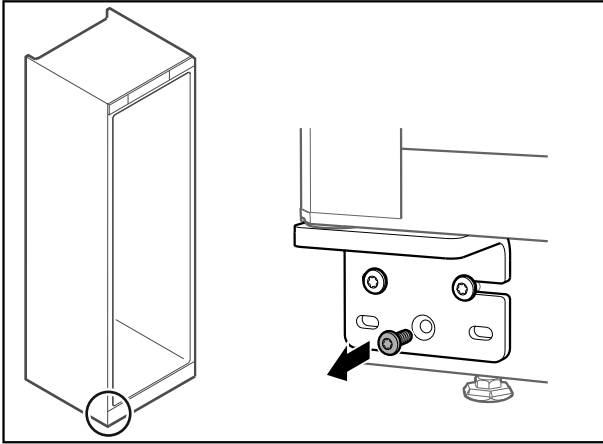

Fig. 56

- ▶ Remove the middle screw on the lower hinge.

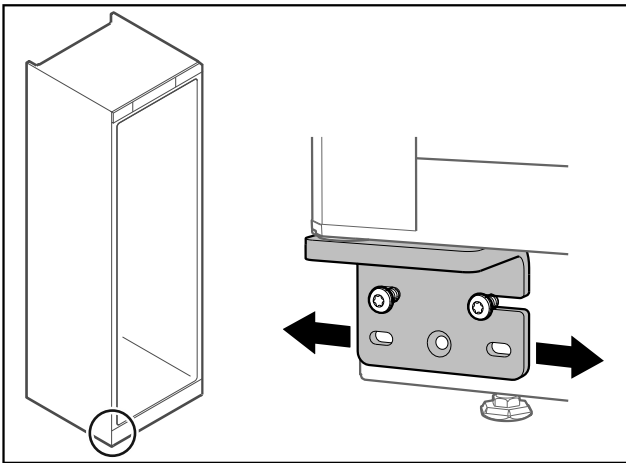

Fig. 57

- ▶ Slightly undo both screws and move the door with the hinge to the left or right.
- ▶ Fully tighten the screws (the middle screw is no longer needed).
- ▷ The door is now straight.

## 4.15 Connecting the appliance



### WARNING

Danger of fire due to incorrect connection!  
Burns.

Damage to the appliance.

- ▶ Do not use an extension cord.
- ▶ Do not use a multipoint connector strip.

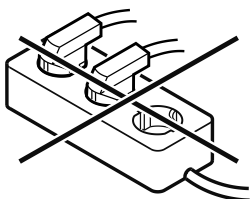

### NOTICE

Danger of damage to incorrect connection!  
Damage to the appliance.

- ▶ Do not connect the appliance to a stand-alone inverter, e.g. solar power systems and petrol generators.

### Note

Only use the supplied power cable.

Make sure that the following requirements are fulfilled:

- The appliance is operated using **alternating current** only.
- The permitted voltage and frequency are printed on the type plate. The type plate position can be seen in the appliance overview chapter. (see 1.2 Overview of appliance and equipment)
- The socket is grounded and fused in accordance with regulations.
- The tripping current for the fuse is between 10 A and 16 A.
- The socket is easily accessible.
- ▶ Check the electrical connection.
- ▶ Insert the appliance plug on the rear side of the appliance. Ensure that it engages correctly.
- ▶ Connect the power plug to the power supply.
- ▷ The display switches to the standby symbol.

## 4.16 Switching on the appliance (first use)

Make sure that the following requirements are fulfilled:

- Appliance is set up and connected.
- All adhesive strips, adhesive and protective films and transport locks are removed from inside and outside the appliance.

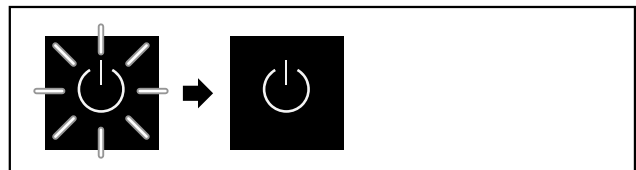

Fig. 58 Example illustration

The standby symbol flashes until the startup process is complete.

The standby symbol is shown in the display.

If the appliance has been supplied with factory settings, the screen language first needs to be selected when using for the first time.

## Storage

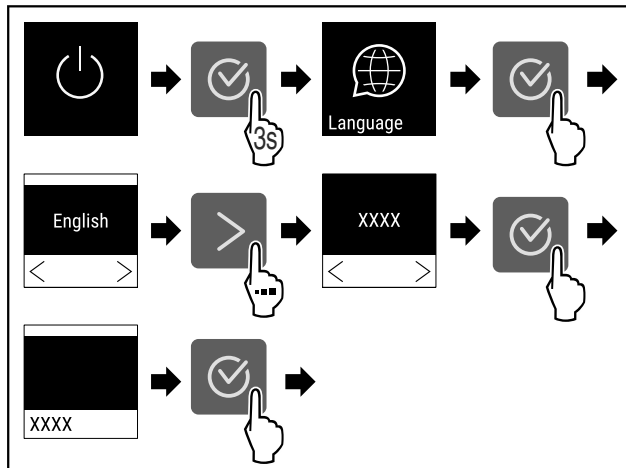

Fig. 59

- ▶ Carry out action steps according to the illustration.

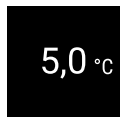

Fig. 60

- ▷ The appliance is switched on once the temperature appears on the display.
- ▷ The temperature display flashes until the set temperature is reached.

## 5 Storage

### 5.1 Information regarding storing items

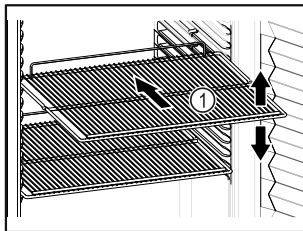

Fig. 61 Example illustration

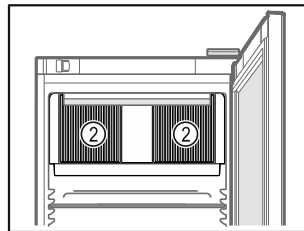



Fig. 62

When stocking items, observe the following:

- ❑ If there are adjustable shelves Fig. 61 (1), position them as required.
- ❑ Observe maximum load weight. (see 9.1 Technical data)
- ❑ Do not stock appliance until the storage temperature has been reached (maintain cold chain).
- ❑ Ventilation slots Fig. 62 (2) for recirculation fan in the interior must be kept clear.
- ❑ Refrigerated goods must not touch the rear wall.
- ❑ Do not store refrigerated goods beyond the rear stop of the support grates.
- ❑ Keep liquids in closed containers.

- ❑ Leave space when storing items for refrigeration to ensure adequate air circulation.
- ❑ Do not stack refrigerated products above the indicated height.  This is important for free air circulation and even temperature distribution in the interior.
- ❑ Do not store refrigerated goods under the defrost water bowl.

## 6 Use

### 6.1 Control and display elements

The display provides a quick overview of the current appliance status, the temperature setting, the status of functions and settings as well as alarm and error messages.

It is operated using the navigation arrows and confirmation symbol.

Functions can be activated or deactivated and settings values can be changed.

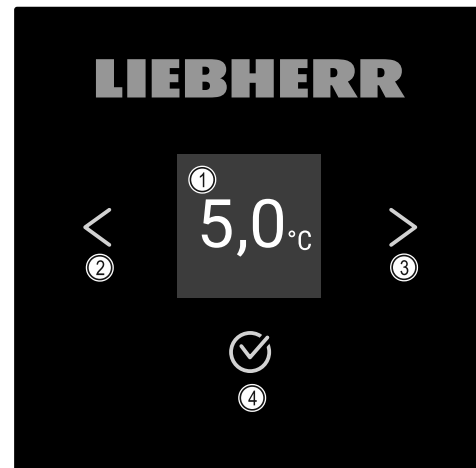

Fig. 63 Display

- (1) Status display
- (2) Backward navigation arrow
- (3) Forward navigation arrow
- (4) Confirm

#### 6.1.1 Status display





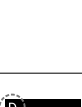

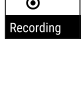

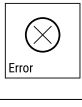





Fig. 64 Status display with actual temperature

The status display shows the actual temperature and is the home display. You navigate from here to the other functions and settings. The status display may show a range of display symbols.

## 6.1.2 Display symbols

The display symbols provide information about the current status of the appliance.

Symbol	Appliance status
	<b>Standby</b> Appliance is switched off.
	<b>Flashing standby symbol</b> Appliance is starting up.
	<b>Flashing temperature</b> Target temperature not yet reached. Appliance cooling to set temperature.
	<b>Temperature display</b> Displays the current interior temperature.
	<b>Display alternating between temperature/defrost symbol with white bar</b> Appliance is in manual defrosting mode.
	<b>D in the display</b> Appliance is in DemoMode.
	<b>Maintenance reminder</b> The time set interval has expired.
	<b>Data memory full</b> The data memory (999 hours) is full. From now, the oldest data will be overwritten.
	<b>Flashing symbol</b> A fault is still present.
	<b>Error symbol</b> Appliance is still malfunctioning.
	<b>White bar at the bottom</b> Submenu
	<b>White bar at the top</b> Default, active setting or active value.

Symbol	Appliance status
	<b>Increasing bar</b> Press button for 3 seconds to activate setting.
	<b>Decreasing bar</b> Press button for 3 seconds to deactivate setting.

Status display symbols

## 6.1.3 Acoustic signals

A signal sounds in the following cases:

- If a function or a value is confirmed.
- If a function or a value can neither be activated nor deactivated.
- As soon as a fault occurs.
- If there is an alarm message.

The alarms can be switched on and off in the customer menu.

## 6.2 Appliance functions

### 6.2.1 Notes on the appliance functions

The appliance functions are set at the factory so that your appliance is fully functional.

Before you alter, activate or deactivate the appliance functions, make sure that the following requirements are met:

- You have read and understood the descriptions of how the display works. (see 3 Functionality of the Touch display)
- You have familiarized yourself with the operating and display elements of your appliance. (see 6.1 Control and display elements)

### 6.2.2 Switching appliance on and off

Using this setting the entire appliance can be switched on and off.

#### Switching on the appliance

**Without activated DemoMode:**

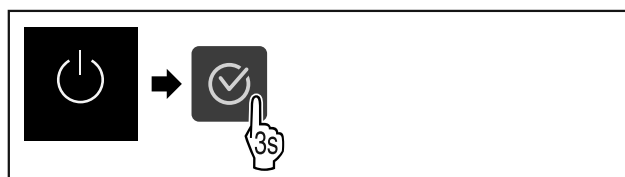

Fig. 65

► Carry out action steps according to the illustration.

**With activated DemoMode:**

## Use

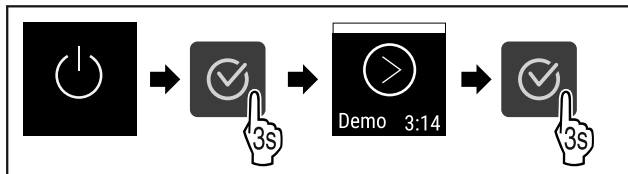

Fig. 66

► Carry out action steps according to the illustration.

### Note

Deactivate DemoMode before the countdown finishes.

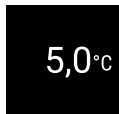

Fig. 67

▷ The temperature appears on the display.

### Switching off the appliance

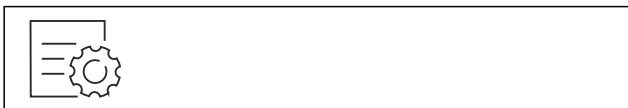

Fig. 68

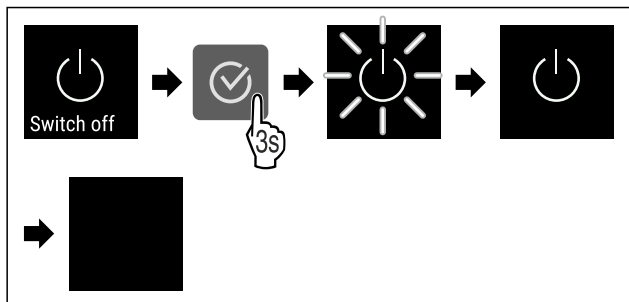

Fig. 69

► Carry out action steps according to the illustration.  
▷ Standby symbol is shown in the display.  
▷ Display switches off after approximately 10 minutes.

## 6.2.3 Temperature



The temperature depends on the following factors:

- How often the door is opened
- How long the door is open for
- The room temperature of the installation site
- The type, temperature and amount of refrigerated items

### Note

The temperature may differ from the temperature displayed in some areas of the interior.

## Setting the temperature



Fig. 70

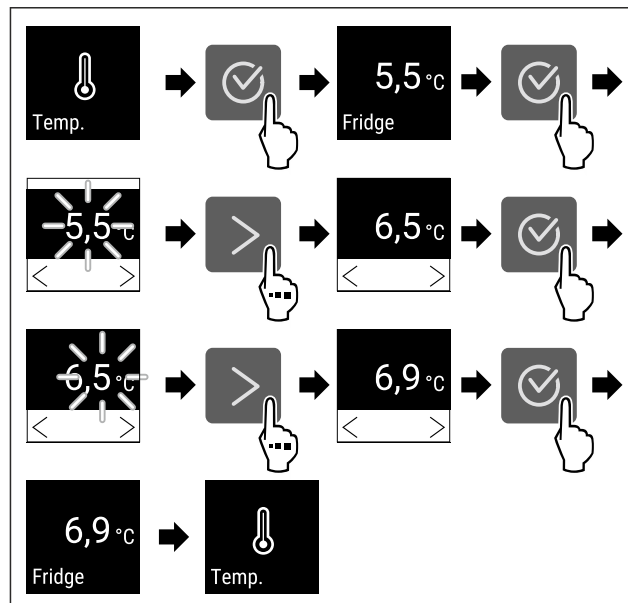

Fig. 71 Changing temperature from 5.5 °C (42 °F) to 6.9 °C (44 °F)

► Carry out action steps according to the illustration.  
▷ Temperature is set.

## 6.2.4 Temperature recording



The appliance displays the minimum and maximum temperatures of the interior. The recording of these temperatures starts automatically after the appliance is switched on; they are recorded at one minute intervals. A note indicating that the data memory is full is displayed after 999 hours (approx. 40 days). The temperature recording should then be reset.

### Note

We recommend resetting the temperature recording once **after reaching the set temperature** when the appliance is commissioned. This ensures that the value displayed for the maximum temperature is a meaningful value.

### Displaying temperature recording

The temperature recording displays the length of the recording and the minimum and maximum temperatures measured during this period of time.





Fig. 72

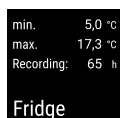

Fig. 73

- ▷ Status screen with the temperature recordings is displayed.

### Resetting temperature recording

The displayed minimum and maximum temperatures can be reset at any time. This deletes the displayed values and the recording interval starts again.

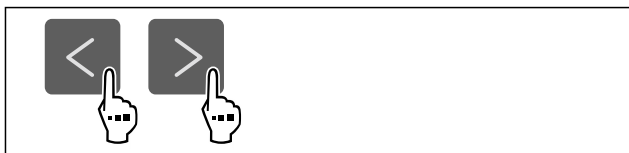

Fig. 74

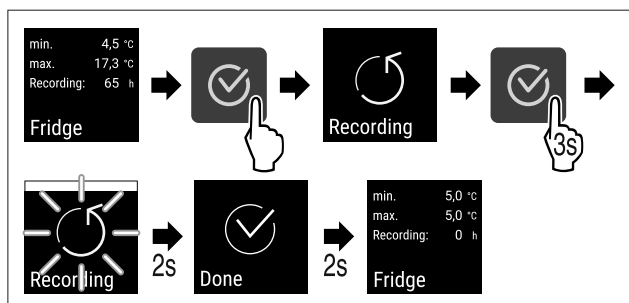

Fig. 75

- ▶ Carry out steps according to the illustration.
- ▷ Temperature recording is reset.
- ▷ Reminder interval is reset.

## 6.2.5 Settings menu access protection



This setting enables the settings menu access protection via a three-digit PIN code.

Application:

- Prevent settings and functions being changed unintentionally.
- Prevent the appliance from being switched off unintentionally.
- Avoid unintentional temperature adjustment.

### Activating the settings menu access protection



Fig. 76

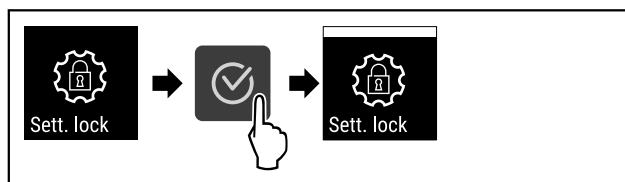

Fig. 77

- ▶ Carry out action steps according to the illustration.
- ▷ Settings menu access protection is activated.

### Changing the access protection PIN code for the settings menu

See: (see 6.2.6 Access codes)

### Deactivating the settings menu access protection



Fig. 78

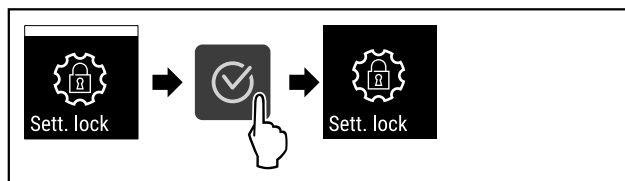

Fig. 79

- ▶ Carry out action steps according to the illustration.
- ▷ Settings menu access protection is deactivated.

### Opening protected settings menu

If the access protection is active, it is necessary to enter the PIN code to open the settings menu.

After entering the correct PIN code, the settings menu remains unlocked for 20 minutes unless you jump back to the status display.

#### Note

- ▶ In the following example, the factory-set PIN code: **1 1 1** is used.

### Access protection for the settings menu must be active.

- ▶ Tap navigation arrow repeatedly until corresponding function is displayed.



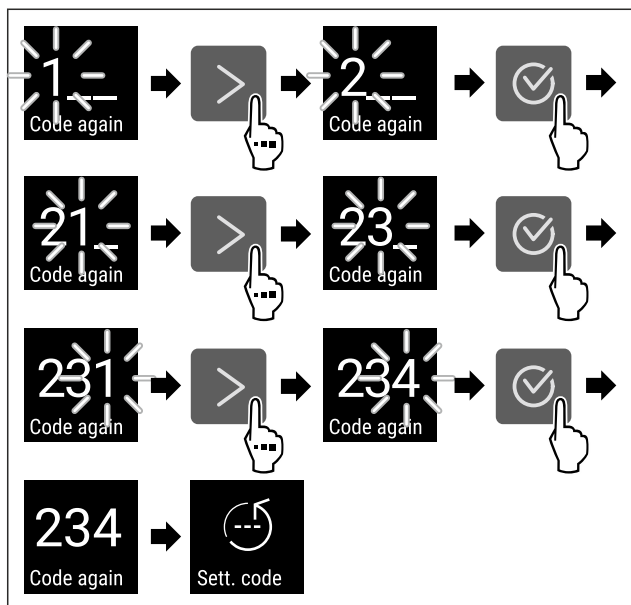

Fig. 84

- ▶ Carry out action steps according to the illustration.
- ▷ Confirmation of the new settings code.
- ▷ The settings code has been changed.

### Resetting the settings code

The settings code for the settings menu access protection has been forgotten or is not known.

- ▶ Reset the appliance to factory settings (see 6.2.25 Resetting to factory settings ).
- ▷ The appliance is reset to the original settings.
- ▷ The factory-set settings code is: **1 1 1**

### 6.2.7 Maintenance interval reminder

Setting for the time interval after which a maintenance reminder is issued.

The following values can be set:

- 7 days
- 14 days
- 30 days
- 60 days
- 90 days
- 180 days
- 360 days
- 720 days
- 1080 days
- Off

#### Setting maintenance interval reminder

The following steps describe how the maintenance interval is set.



Fig. 85

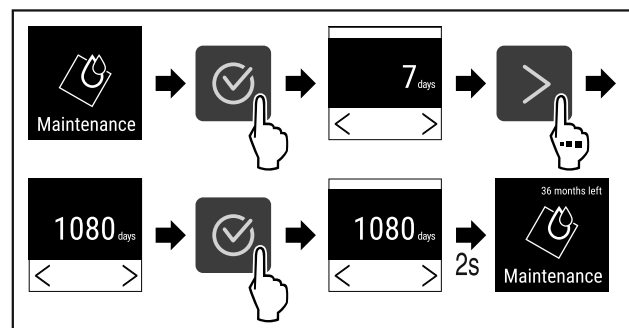

Fig. 86

- ▶ Carry out action steps according to the illustration.
- ▷ The time interval, after which the maintenance reminder is issued, is set.
- ▷ The remaining time is displayed.

### 6.2.8 Language

This setting allows the display language to be set.

#### Setting the language



Fig. 87

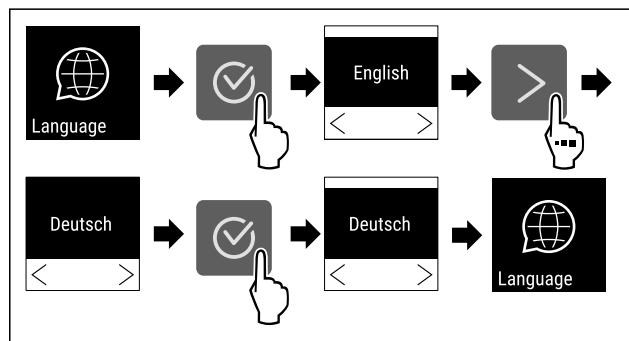

Fig. 88

- ▶ Carry out action steps according to the illustration.
- ▷ The selected language is set.

### 6.2.9 Temperature unit

Use this function to set the temperature unit. You can set the temperature unit in either degrees Celsius or degrees Fahrenheit.

#### Setting the temperature unit



Fig. 89

## Use

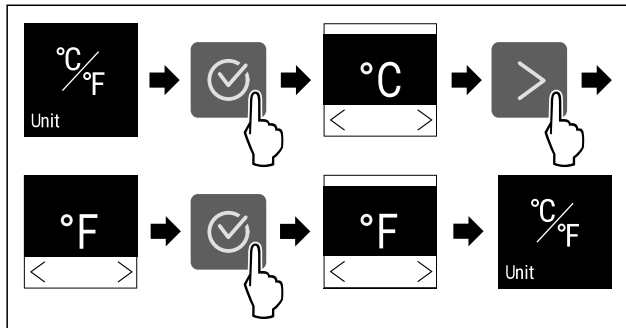

Fig. 90 Example illustration: Switching between degrees Celsius or degrees Fahrenheit.

- ▶ Carry out action steps according to the illustration.
- ▷ Temperature unit is set.

### 6.2.10 Display Brightness



Use this function to set the brightness of the display gradually.

You can set the following brightness levels:

- 40 %
- 60 %
- 80 %
- 100% (default setting)

#### Setting the brightness

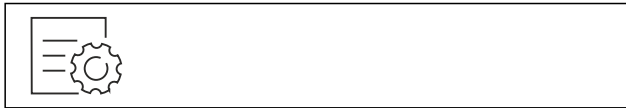

Fig. 91

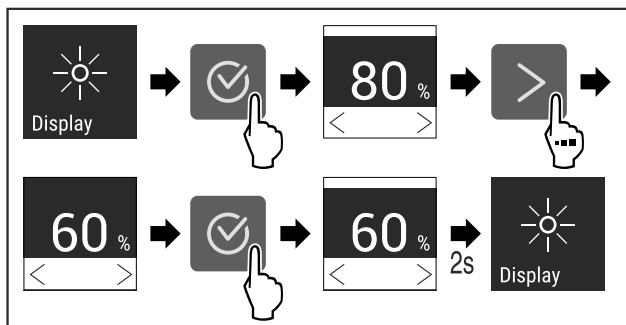

Fig. 92 Example illustration: Switching from 80% to 60%.

- ▶ Carry out action steps according to the illustration.
- ▷ Brightness is set.

### 6.2.11 Alarm Sound



This function enables all alarm sounds, such as the door alarm, to be switched on and off.

#### Activating Alarm Sound



Fig. 93

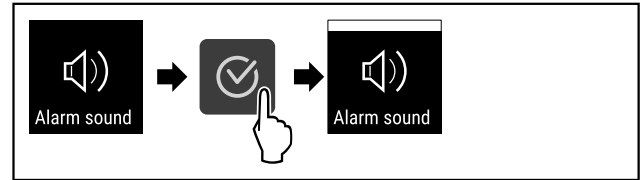

Fig. 94

- ▶ Carry out action steps according to the illustration.
- ▷ Alarm Sound is activated.

#### Deactivating Alarm Sound



Fig. 95

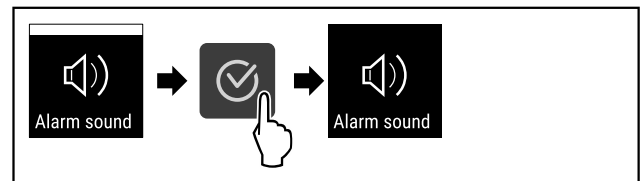

Fig. 96

- ▶ Carry out action steps according to the illustration.
- ▷ Alarm Sound is deactivated.

### 6.2.12 Key Sound



This function makes it possible to switch all confirmation sounds and the Startsound on and off.

#### Activating Key Sound

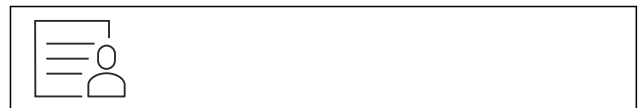

Fig. 97

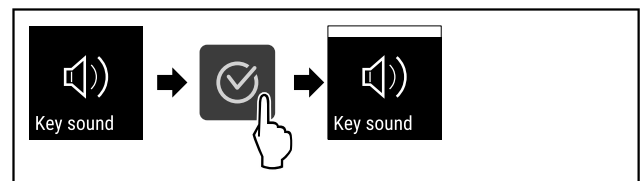

Fig. 98

- ▶ Carry out action steps according to the illustration.
- ▷ Key Sound is activated.

## Deactivating Key Sound



Fig. 99

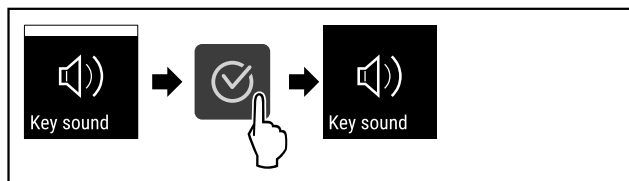

Fig. 100

- ▶ Carry out action steps according to the illustration.
- ▷ Key Sound is deactivated.

## 6.2.13 WiFi connection



### Note

Liebherr SmartMonitoring Dashboard is not available in all countries. Check availability via the QR code by entering your model.

### Note

Use of the Liebherr SmartMonitoring Dashboard at <https://smartmonitoring.liebherr.com> requires installation of a SmartModule and a commercial MyLiebherr account. When commissioning online you can register using your login data, or register again and create a company account.

This setting establishes a wireless connection between the appliance and the internet. The connection is controlled via the SmartModule. The appliance can be integrated via the browser-based [Liebherr SmartMonitoring Dashboard](#) and advanced options and customized methods relating to control, administration and monitoring can be used.

### Note

Accessories are available from the Liebherr Service Center. The address for your respective country can be found on the back of the instructions.

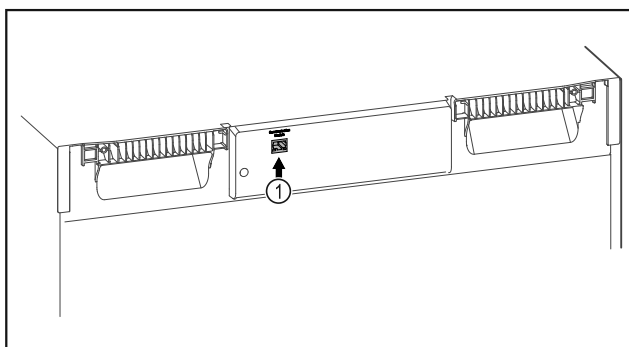

Fig. 101

Make sure that the following requirements are fulfilled:

- SmartModule Fig. 101 (1) is in use.

### Establishing a connection

You commission and set up your SmartModule online via the [Liebherr SmartMonitoring Dashboard](#) on your web-enabled device.

On the [Liebherr SmartMonitoring Dashboard](#) information is also available about retrofitting the Smart-Module.



Fig. 102

- ▶ Open the [Liebherr SmartMonitoring Dashboard](#) (see Fig. 102).

On the fridge or freezer:



Fig. 103

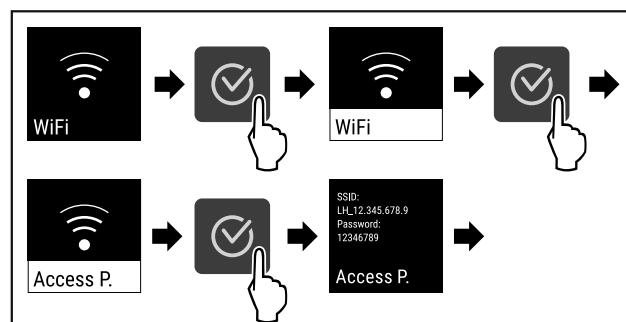

Fig. 104

- ▶ Carry out action steps according to the illustration.
- ▶ Continue the set-up procedure on your web-enabled device: [Liebherr SmartMonitoring Dashboard](#)

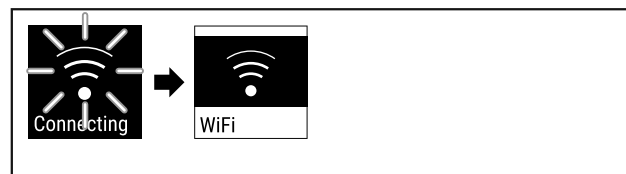

Fig. 105

- ▶ Connection is established.
- ▷ WiFi connecting appears. The symbol flashes.
- ▶ Follow the [Liebherr SmartMonitoring Dashboard](#) instructions.
- ▷ Connection is established.

# Use

## Disconnecting



Fig. 106

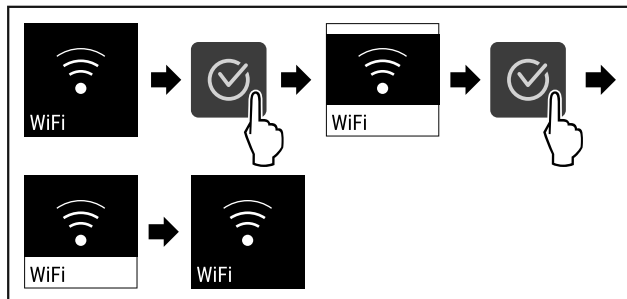

Fig. 107

- ▶ Carry out action steps according to the illustration.
- ▷ There is no connection.

## Resetting connection



Fig. 108

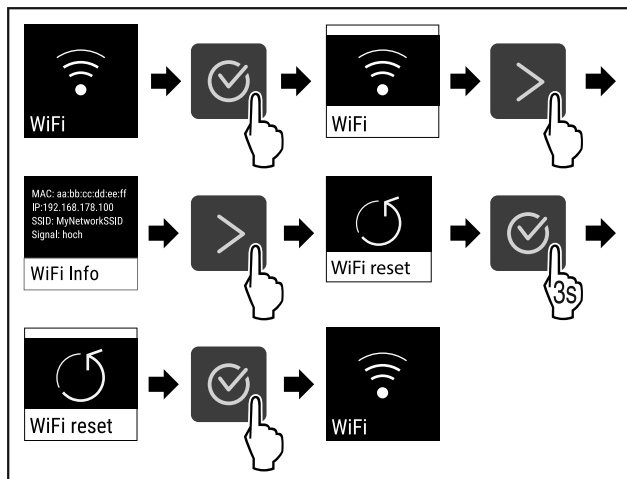

Fig. 109

- ▶ Carry out action steps according to the illustration.
- ▷ The WiFi settings are restored to the factory settings.

## 6.2.14 LAN connection

### Note

Liebherr SmartMonitoring Dashboard is not available in all countries. Check availability via the QR code by entering your model.

### Note

Use of the Liebherr SmartMonitoring Dashboard at <https://smartmonitoring.liebherr.com> requires installation of a SmartModule and a commercial MyLiebherr account. When commissioning online you can register using your login data, or register again and create a company account.

This setting establishes a wired connection between the appliance and the internet. The connection is controlled via the SmartModule. The appliance can be integrated via the browser-based [Liebherr SmartMonitoring Dashboard](#) and advanced options and customized methods relating to control, administration and monitoring can be used.

### Note

Accessories are available from the Liebherr Service Center. The address for your respective country can be found on the back of the instructions.

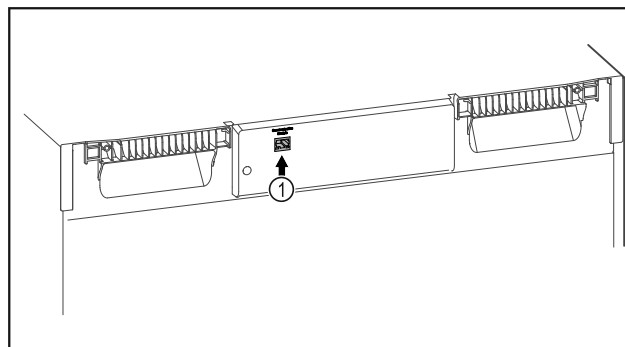

Fig. 110

- Make sure that the following requirements are fulfilled:
- SmartModule *Fig. 110 (1)* is in use.
- A network cable is connected.

### Establishing a connection

You commission and set up your SmartModule online via the [Liebherr SmartMonitoring Dashboard](#) on your web-enabled device.

On the [Liebherr SmartMonitoring Dashboard](#) information is also available about retrofitting the SmartModule.



Fig. 111

- ▶ Open the [Liebherr SmartMonitoring Dashboard](#) (see Fig. 111).

On the fridge or freezer:



Fig. 112

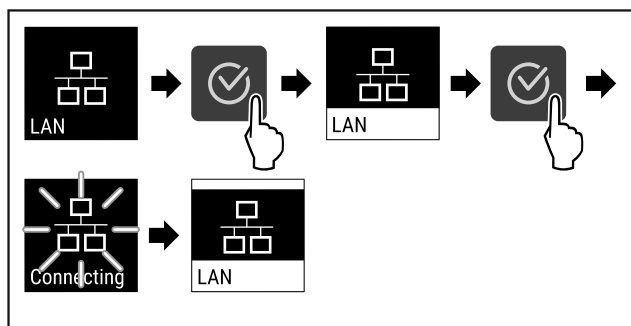

Fig. 113

- ▶ Carry out action steps according to the illustration.
- ▷ Connection is established: LAN connecting appears. The symbol flashes.
- ▶ Follow the [Liebherr SmartMonitoring Dashboard](#) instructions.
- ▷ Connection is established.

**Disconnecting**



Fig. 114

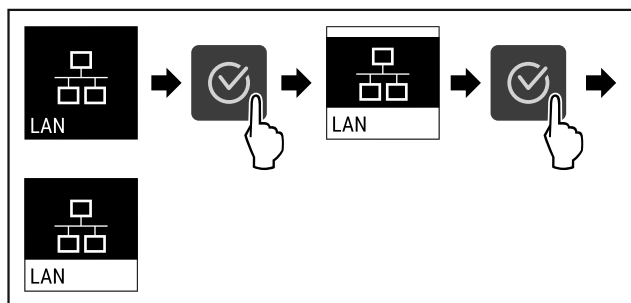

Fig. 115

- ▶ Carry out action steps according to the illustration.
- ▷ There is no connection.

**6.2.15 Appliance information**



Use this function to display the model name, index, serial number and service number of your appliance. You will need the appliance information when you contact customer service. (see 9.3 Customer Service)  
 You also use this function to open the expanded menu. (see 3 Functionality of the Touch display)

**Display appliance information**

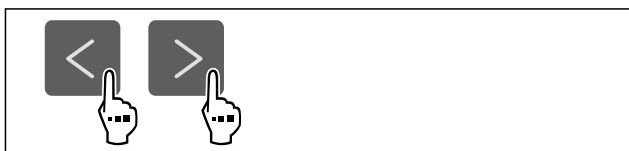

Fig. 116



Fig. 117

- ▶ Carry out action steps according to the illustration.
- ▷ Display shows the appliance information.

**6.2.16 Operating hours**



The display shows the appliance operating hours.

**Displaying operating hours**

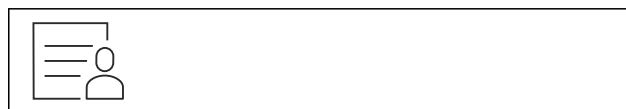

Fig. 118



Fig. 119

- ▷ The operating hours appear.

**6.2.17 Software**



Use this function to display the software version of your appliance.

**Display software version**



Fig. 120



Fig. 121

- ▶ Carry out action steps according to the illustration.
- ▷ Display indicates the software version.

**6.2.18 Defrosting**



The appliance defrosts automatically in normal mode.

Application:

- If there is excessive ice in the interior, the defrosting function can be started manually.

# Use

## Manually starting automatic defrosting

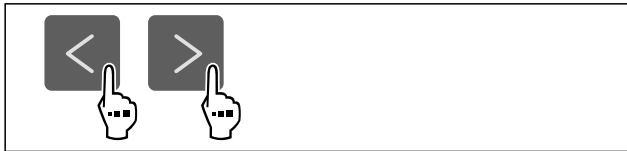

Fig. 122

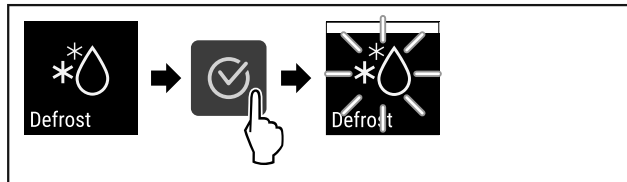

Fig. 123

- ▶ Carry out action steps according to the illustration.
- ▷ Automatic defrosting has been started. The appliance automatically switches back to normal mode once defrosting has finished.

### Note

If there is still ice in the interior after starting automatic defrosting several times, defrost the appliance manually. (see 8.2 Defrosting the appliance)

## Canceling manually started defrosting

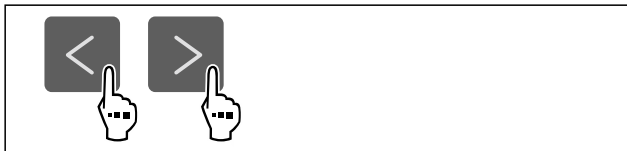

Fig. 124

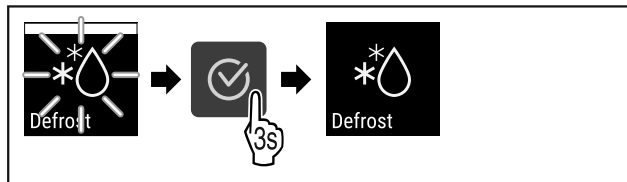

Fig. 125

- ▶ Carry out action steps according to the illustration.
- ▷ Manually started defrosting is canceled. The appliance automatically switches back to normal mode.



### Defrosting info

This setting adjusts the display during an automatic defrosting process.

The following display variants are available:

- **Def 1:** The temperature display is not updated and shows the last temperature before automatic defrosting was started.
- **Def 2:** The “automatic defrosting” note is displayed on the status screen. The temperature display continuously updated and shows the actual temperature.

- **Def 3:** The “automatic defrosting” note is displayed on the status screen. The temperature display is not updated and shows the last temperature before automatic defrosting was started.
- **Def 4:** The “automatic defrosting” note is displayed on the status screen. The temperature display is not updated and shows the last temperature before automatic defrosting was started.

**Defrosting** Fig. 126 “Automatic defrosting process” note



Fig. 127

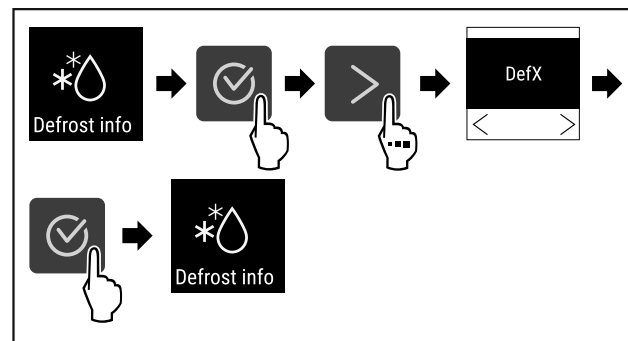

Fig. 128

- ▶ Carry out action steps according to the illustration.
- ▷ The desired display variant has been selected.



## 6.2.19 Sensor calibration

The sensor calibration is used to realign differences between the temperature displayed and the actual temperature in the appliance.

Setting range: +/- 3 Kelvin in 0.1 Kelvin increments.

### Calibrating the sensor

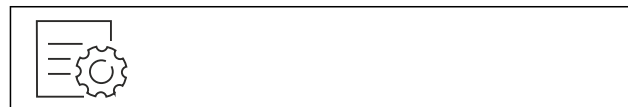

Fig. 129



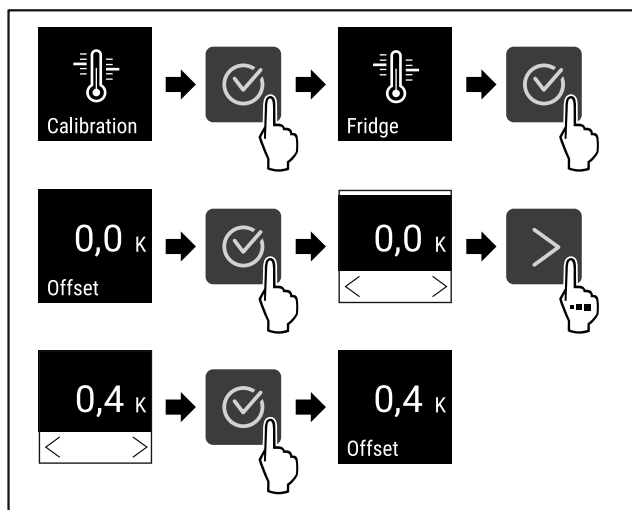

Fig. 130

- ▶ Carry out action steps according to the illustration.
- ▷ The sensor is calibrated.

**Note**

The calibrated temperature is shown on the display within two hours.

**6.2.20 Temperature alarm**



The temperature alarm is triggered as soon as the interior temperature differs from the adjustable temperature range and any set delay time has elapsed.

The following values can be set:

- Lower temperature limit in 0.1 °C ( °F) increments
- Upper temperature limit in 0.1 °C ( °F) increments
- Alarm delay time from 0 to 60 minutes (setting “0” means no alarm repetition at the alarm relay.)
- Alarm repetition frequency of between 0 and 30 minutes

**Setting temperature alarm**



Fig. 131

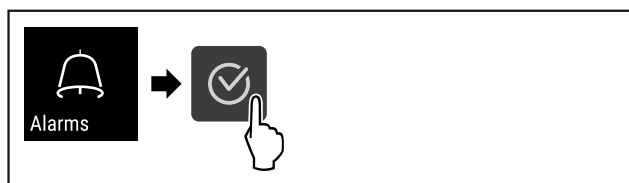

Fig. 132

- ▶ Carry out action steps according to the illustration.

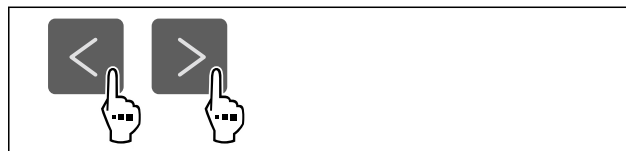

Fig. 133

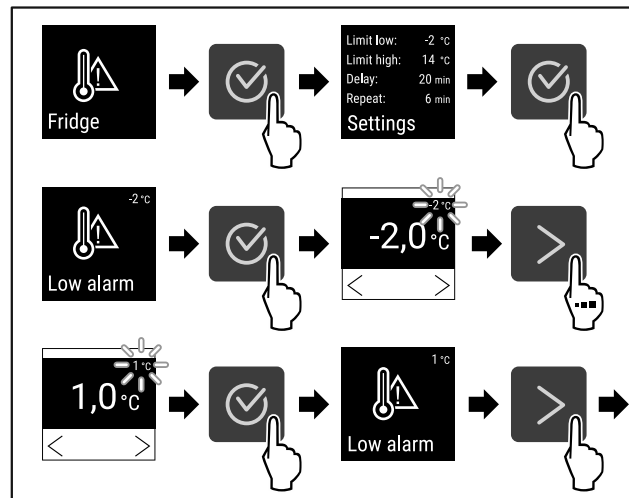

Fig. 134

- ▶ Carry out action steps according to the illustration.
- ▷ Lower temperature limit has been set.

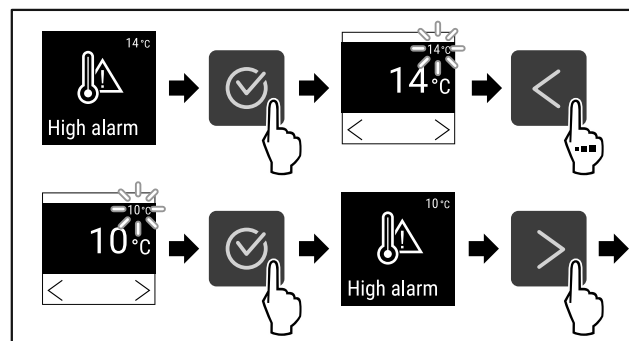

Fig. 135

- ▶ Carry out action steps according to the illustration.
- ▷ Upper temperature limit has been set.

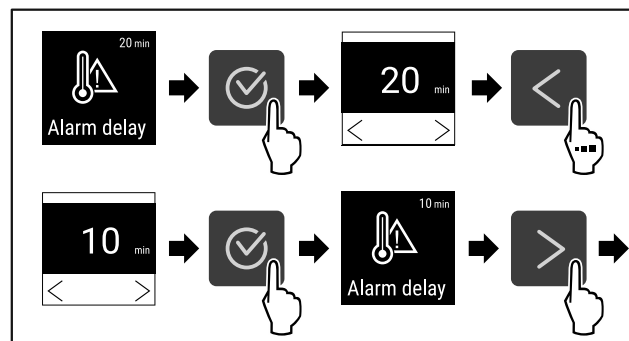

Fig. 136

- ▶ Carry out action steps according to the illustration.
- ▷ Alarm delay time has been set.

# Use

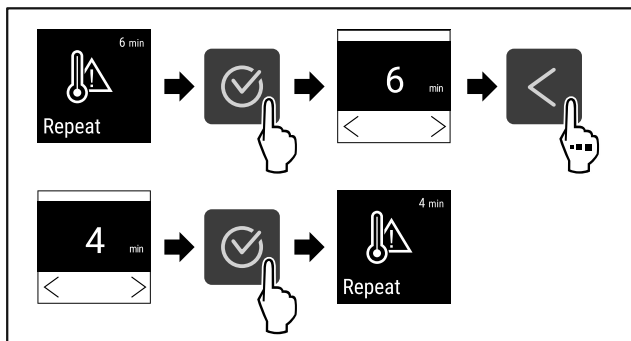

Fig. 137

- ▶ Carry out action steps according to the illustration.
- ▷ Alarm repetition interval has been set.
- ▷ Temperature alarm has been set.

## Displaying set temperature alarm values



Fig. 138

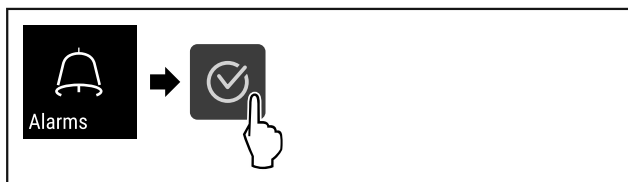

Fig. 139

- ▶ Carry out action steps according to the illustration.



Fig. 140

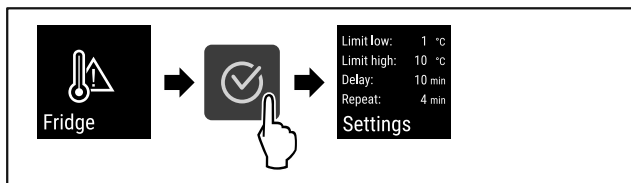

Fig. 141

- ▶ Carry out action steps according to the illustration.
- ▷ Set temperature alarm values are displayed.

## 6.2.21 Door alarm

Use this function to activate or deactivate the door alarm. The door alarm sounds if the door is open for too long. The door alarm is activated upon delivery. You can set how long the door can remain open until the door alarm sounds.

You can set the following values:

- 15 seconds
- 30 seconds
- 60 seconds
- 90 seconds
- 120 seconds
- 150 seconds
- 180 seconds
- Off

## Setting the door alarm



Fig. 142

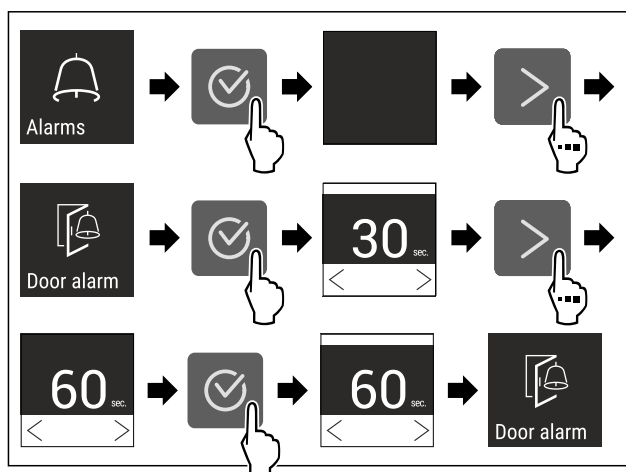

Fig. 144 Example illustration: Changing the door alarm from 30 seconds to 60 seconds.

- ▶ Carry out action steps according to the illustration.
- ▷ Door alarm is set.

## Deactivating door alarm



Fig. 145

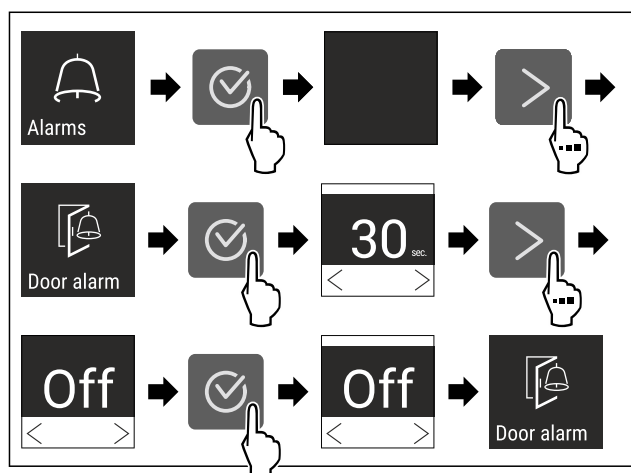

Fig. 146

- ▶ Carry out action steps according to the illustration.
- ▷ Door alarm is deactivated.

### 6.2.22 Alarm simulation



This setting makes it possible to simulate a change in the appliance temperature to check the function of any safety devices that may be connected.

#### Starting alarm simulation



Fig. 147

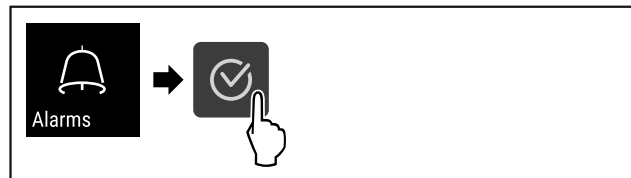

Fig. 148

- ▶ Carry out action steps according to the illustration.

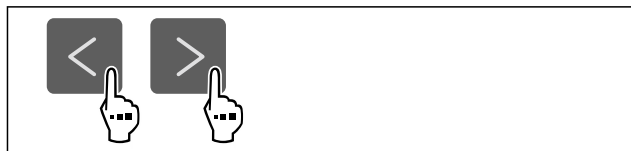

Fig. 149

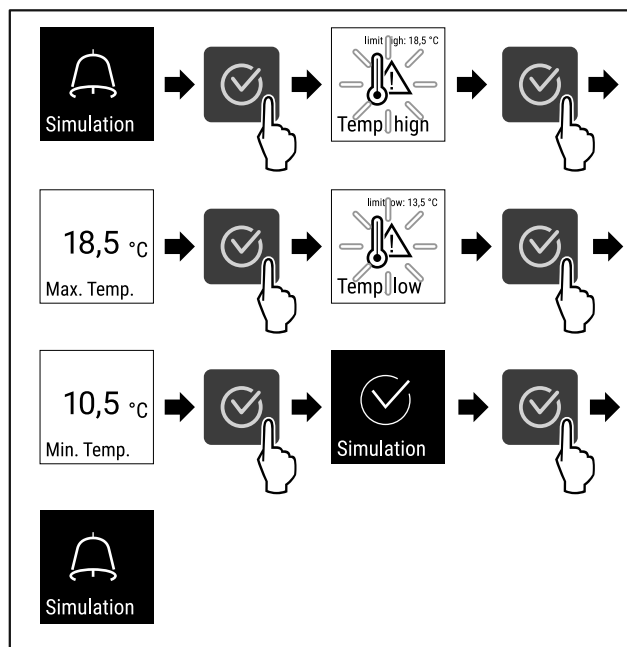

Fig. 150

- ▶ Carry out action steps according to the illustration.
- ▷ The simulation has been performed.
- ▷ Connected safety devices should have triggered.

### 6.2.23 Alarm relay



This setting makes it possible to relay one or more alarms to an external alarm receiver connected to the appliance.

The following settings can be selected:

- Alarm type:
  - Door alarm
  - Temperature alarm
  - Door alarm and temperature alarm
  - All
- Confirm:
  - **Yes:** The alarm is terminated at the appliance and the externally connected receiver.
  - **No:** The alarm is acknowledged at the appliance and remains active at the receiver until the error is rectified.
- Update (only visible if “Yes” is selected when confirming):
  - **Yes:** Alarm repeats.
    - Temperature alarm** depending on the set time (see 6.2.20 Temperature alarm ) (If the alarm delay time is set to “0”, the alarm relay will not repeat the alarm.)
    - Door alarm** after 1 or 4 minutes \* (see 6.2.21 Door alarm )
  - **No:** Alarm permanently acknowledged.

## Activating alarm relay



Fig. 151

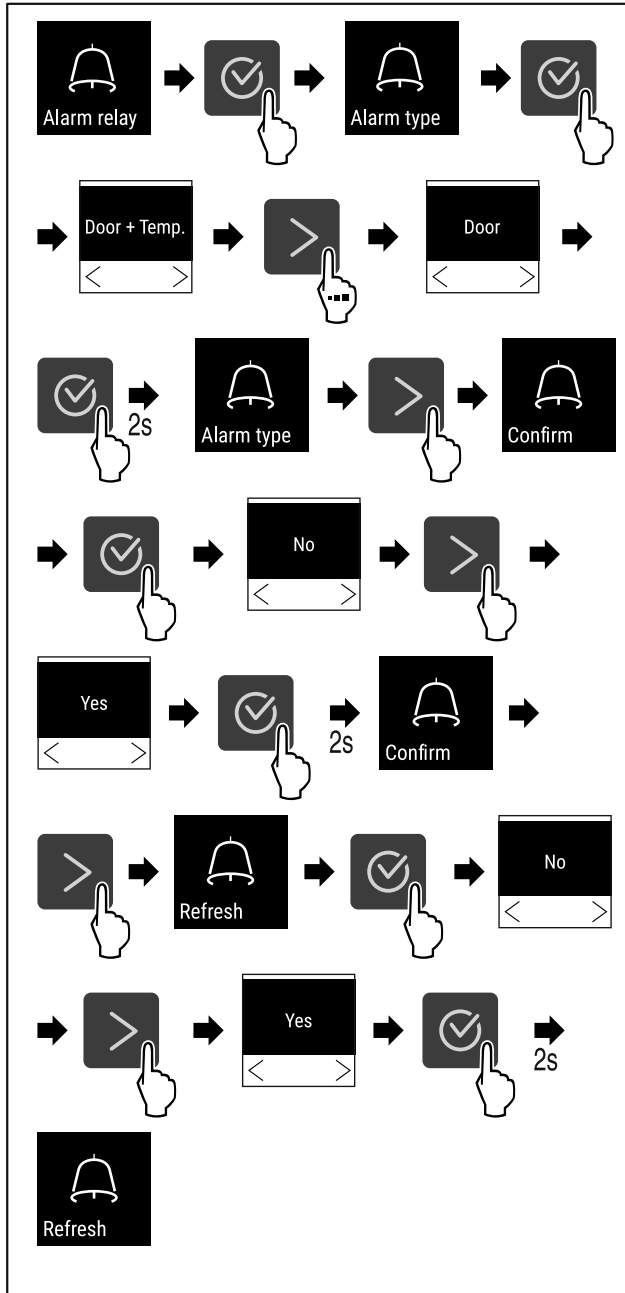

Fig. 152

- ▶ Carry out action steps according to the illustration.
- ▷ The alarm relay has been set.

## 6.2.24 Demo mode



Demo mode is a special feature for dealers who want to demonstrate appliance features. If you activate demo mode, all refrigeration functions are deactivated. If you switch on your appliance and a “D” appears on the status display, demo mode is already activated. If you activate and then deactivate demo mode, the appliance will be reset to factory defaults. (see 6.2.25 Resetting to factory settings )

### Activating demo mode



Fig. 153

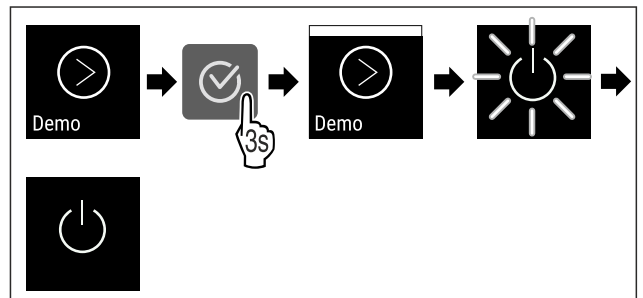

Fig. 154

- ▶ Carry out action steps according to the illustration.
- ▷ Demo mode is activated.
- ▷ Appliance is switched off.
- ▶ Switch on the appliance. (see 4.16 Switching on the appliance (first use))
- ▷ “D” appears in the status display.

### Deactivating demo mode



Fig. 155

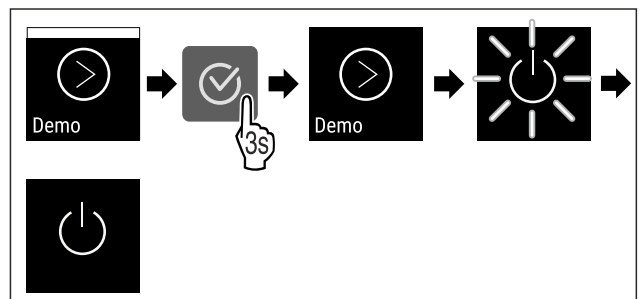

Fig. 156

- ▶ Carry out action steps according to the illustration.
- ▷ Demo mode is deactivated.
- ▷ Appliance is switched off.
- ▶ Switch on the appliance. (see 4.16 Switching on the appliance (first use))

▷ Appliance is reset to factory settings.

### 6.2.25 Resetting to factory settings



Use this function to reset all settings to factory settings. All settings you have made so far are reset to their original settings.

#### Performing a reset



Fig. 157

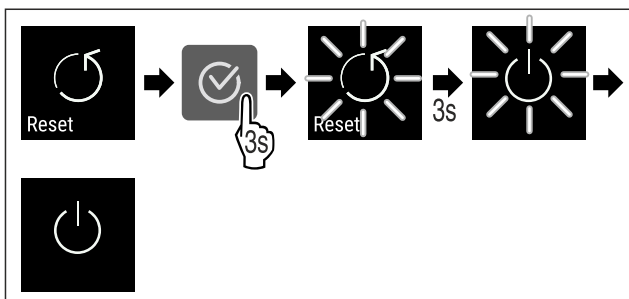





Fig. 158

- ▶ Carry out action steps according to the illustration.
- ▷ Appliance is reset.
- ▷ Appliance is switched off.
- ▶ Restart the appliance. (see 4.16 Switching on the appliance (first use))











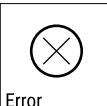

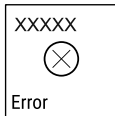

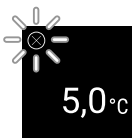
## 6.3 Messages

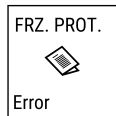

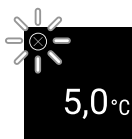





### 6.3.1 Warnings

Warnings are issued by means of an audio signal and visually via a symbol on the display. The signal gets louder until the warning is acknowledged.

Message	Cause	Remedy
 <b>Door open</b>	The message appears if the door is open for too long.	Close the door. Press the confirmation button. Alarm is ended. <b>Note</b> You can set how long it takes for this message to appear (see 6.2.21 Door alarm ). 
 <b>Temperature alarm</b>	This message appears if the temperature does not match the set temperature. Reasons for the differences in temperature can be: - Warm items for refrigeration have been placed inside. - Too much warm room air flowed in when rearranging and removing refrigerated products. - The power was cut off for a prolonged period.	Press the confirmation button. The warmest temperature is displayed. Press the confirmation button. The current temperature flashes and the display alternates with the temperature alarm symbol until the set temperature is reached. Check the quality of the chilled goods.  

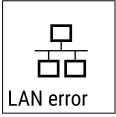

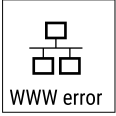

# Use

Message	Cause	Remedy
 <p>Error</p> <p><b>Error</b></p>	<p>The appliance is defective, there is an appliance error or an appliance module indicates an error.</p>	<p>Relocate the chilled goods. Press the confirmation button. Error code is displayed.</p>   <p>Press the confirmation button. If present, another error code is displayed.</p>  <p><b>or</b></p> <p>Status screen with flashing error symbol is displayed. Pressing the navigation buttons displays error code(s) again.</p>  <p>Note error code(s) and contact customer service.</p>
	<p>Message indicates that the freezer protection mode is active (e.g. due to frequent door openings or loading with goods).</p>	<p>Press the confirmation button. <b>FRZ.PROT</b> is displayed.</p>   <p>Press the confirmation button. Status screen with flashing error symbol is displayed</p>   <p>Pressing the navigation buttons displays error code again.</p> <p>The appliance automatically switches to normal operating mode after a few hours and the message disappears. If the message is displayed repeatedly and the causes listed do not apply, contact customer service. (see 9.3 Customer Service)</p>
 <p>Power</p> <p><b>Power failure</b></p>	<p>The message appears after an interruption in the power supply if the temperature is above the alarm limit when the power returns.</p>	<p>Press the confirmation button. The warmest temperature and the number of power interruptions are displayed.</p>  <p>Press the confirmation button. Alarm is ended and the current temperature is displayed. Check the quality of the chilled goods.</p> 
 <p>Defrost error</p> <p><b>Defrost error</b></p>	<p>The automatic defrost does not work correctly. The last 5 defrost cycles were not successful.</p>	<p>Press the confirmation button. Alarm is ended.</p>  <p>Contact customer service (see 9.3 Customer Service).</p>

Message	Cause	Remedy
 <p>WiFi error</p> <p><b>WLAN error</b></p>	WLAN connection is interrupted.	Check the connection. Press the confirmation button. Alarm is ended. 
 <p>WWW error</p> <p><b>WLAN WWW error</b></p>	The message appears if there is no Internet connection via WLAN.	Check the connection. Press the confirmation button. Alarm is ended. 
 <p>LAN error</p> <p><b>LAN error</b></p>	LAN connection is interrupted.	Check the connection and network cable. Press the confirmation button. Alarm is ended. 
 <p>WWW error</p> <p><b>LAN WWW error</b></p>	The message appears if there is no Internet connection via LAN.	Check the connection. Press the confirmation button. Alarm is ended. 

### 6.3.2 Reminders

Reminders appear when you are prompted to take action. They are issued by means of an audio signal and visually via a symbol on the display. Acknowledge the message by pressing the confirmation button.

Message	Cause	Remedy
 <p>Maintenance</p> <p><b>Maintenance reminder</b></p>	The message appears when the timer for the set maintenance interval has expired.	 <p>Press the confirmation button. Alarm is ended.</p> <p><b>Note</b> The maintenance interval can be set (see 6.2.7 Maintenance interval reminder).</p>
 <p>Recording</p> <p><b>Logging reminder</b></p>	This message appears when the temperature logging memory (999 hours) is full.	 <p>Press the confirmation button. Alarm is ended. The oldest data is overwritten.</p> <p><b>Note</b> The temperature logging can be reset (see 6.2.4 Temperature recording).</p>

# Equipment

## 7 Equipment

### 7.1 Safety lock

The lock in the appliance door is equipped with a safety mechanism.

#### 7.1.1 Locking appliance

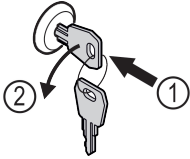

Fig. 159

- ▶ Insert key.
- ▶ Turn key anticlockwise by 90°.
- ▷ The appliance is locked.

#### 7.1.2 Unlocking appliance

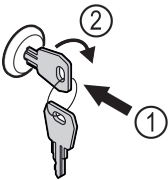

Fig. 160

- ▶ Insert key Fig. 160 (1).
- ▶ Turn key clockwise by 90° Fig. 160 (2).
- ▷ The appliance is unlocked.

### 7.2 Sensors

The appliance can be equipped with the following sensors for temperature monitoring:

- Safety thermostat sensor
- C sensor

#### 7.2.1 Safety thermostat sensor

The safety thermostat sensor monitors the temperature drop and thus protects against excessively low temperatures (Freeze Protect). If the temperature drops below the threshold value, the appliance regulates the temperature automatically. The error message FRZ. PROT (Freeze Protect) (see 6.3 Messages) appears.

##### Note

Do not cover the safety thermostat sensor.

#### 7.2.2 C sensor (control sensor)

The C sensor is permanently installed and regulates the interior temperature of the appliance. You can calibrate the C sensor if necessary. (see 6.2.19 Sensor calibration )

### 7.3 Interfaces

There are various connection options on the back of the appliance.

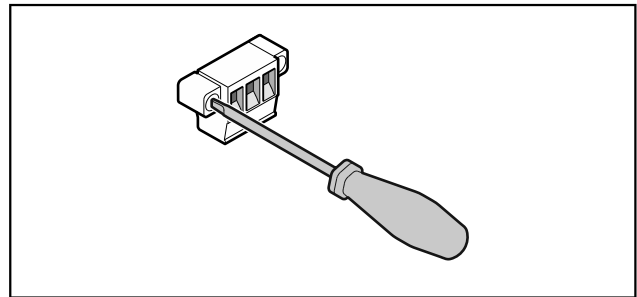

Fig. 161

##### Note

Screws secure the plugs. To enable disconnection of the plugs, loosen the screws on the left and right.

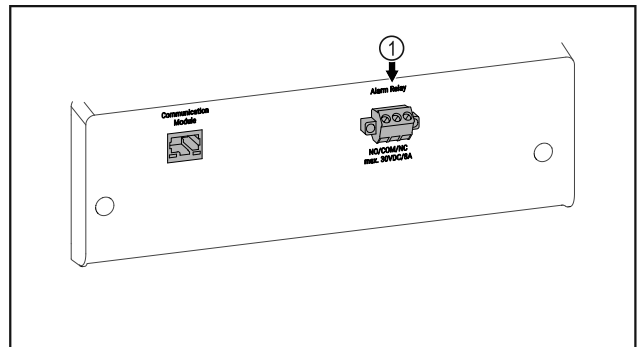

Fig. 162

- (1) Potential-free alarm output

#### 7.3.1 Potential-free alarm output



##### WARNING

Risk of injury due to electric shock!

- ▶ The appliance may only be connected to an external alarm device by trained specialist personnel.

These three contacts can be used to connect a visual or an acoustic alarm device. The connection is designed for a maximum of **30 V (DC) - 8 A** from a safety low voltage source SELV (**minimum current 150 mA**).

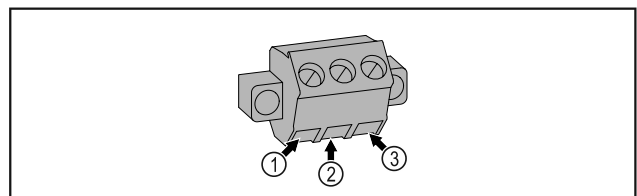



Fig. 163

- (1)** NO (normally open)  
Connection for indicator lamp, which is active in normal operation or when the appliance is switched off.
- (2)** COM (common)  
External voltage source
- (3)** NC (normally closed)  
Connection for alarm lamp or audible alarms, which is active when an alarm is triggered or lack of power supply.



## WARNING

Short-circuit hazard due to live parts!  
Electric shock or damage to the electronics.

- ▶ **Switch off the appliance.**
- ▶ Pull out mains plug or switch off fuse.

## Note

A maintenance reminder function can be activated. (see 6.2.7 Maintenance interval reminder )

## Note

We recommend creating a maintenance log in which all work (repairs, checks) performed is documented.

## Note

Liebherr recommends yearly maintenance. For an individual offer, please contact Customer Service (see 9.3 Customer Service) .

## 8 Maintenance

### 8.1 Maintenance schedule

Maintenance work is to be performed at regular intervals to ensure proper appliance function.



## CAUTION

Danger of injury and damage due to unprofessional maintenance work!

Personal injury and material damage.

- ▶ Maintenance work may only be performed by trained specialist personnel.

Component	Activity	Maintenance interval
Sheet metal parts	Check for damage and corrosion. Replace damaged parts: (see 9.3 Customer Service)	Yearly
Door, hinges	Check alignment (see 4.14 Aligning the door) , ease of movement, and tight fit.	Yearly
Lock, door handle *	Check for ease of movement and tight fit.	Yearly
Door seal	Check for damage, wear, and tight fit. A replacement door gasket is available via Customer Service (see 9.3 Customer Service) .	Yearly
Sensor	Calibrate sensor. (see 6.2.19 Sensor calibration )	Yearly
Sensor feedthrough	Check that the sealing compound is intact.	Yearly
Surfaces	Cleaning (see 8.3 Cleaning the appliance)	Recommendation: monthly or as required/specified at installation location
Surfaces	Disinfection	Recommendation: monthly or as required/specified at installation location

# Maintenance

Component	Activity	Maintenance interval
Installation location, appliance	Decontamination The appliance is suitable for room decontamination with hydrogen peroxide H <sub>2</sub> O <sub>2</sub> . In this context, the values of the following application specifications must not be exceeded: Concentration: maximum 250 ppm. Humidity: maximum 85%. Maximum permissible room temperature as per climate class. (see 1.4 Range of appliance use)	Recommendation: as required/specified at installation location, maximum 2x per year
Fan air slots	Cleaning (see 8.3.3 Cleaning fan cover)	Yearly
Alarm relay		
Power cable	Check for damage.	Yearly or if there is a change of location
Tilt angle	Check for proper function and tight fit.	Yearly or if there is a change of location
Adjusting feet/castors	Check for proper function, damage, and tight fit. Replace damaged parts. (see 9.3 Customer Service)	Yearly
Defrost water collection tray	Check the fill level of the defrost water collection tray and empty if necessary.	Regular visual inspection

## 8.2 Defrosting the appliance



### WARNING

Appliance incorrectly defrosted!  
Injuries and damage.

- ▶ Do not use mechanical devices or other means to accelerate the defrosting process, other than those recommended by the manufacturer.
- ▶ Do not use any electrical heating or steam cleaning equipment, naked flames or defrosting sprays.
- ▶ Do not remove ice with sharp objects.

Defrosting is performed automatically. Defrost water drips into the defrost water collection tray and must be emptied at regular intervals.

### Note

To avoid having to empty the defrost water collection tray frequently, you can place a container under the drain opening in the tray.

The defrost water collection tray may only be inserted on the lowest support rib.

To maintain the functionality of the appliance, we recommend defrosting it when there is a high buildup of ice. Icing in the interior is determined by the location (e.g. high humidity), settings on the appliance and incorrect user behavior.

Manual defrosting:

- ▶ Switch off appliance. (see 6.2.2 Switching appliance on and off )
- ▶ Disconnect power plug.
- ▶ Store refrigerated items elsewhere.
- ▶ Leave the appliance door open during defrosting process.
- ▶ Pull out the defrost water collection tray at the front, empty it and clean the appliance.

## 8.3 Cleaning the appliance

### 8.3.1 Preparing



### WARNING

Short-circuit hazard due to live parts!  
Electric shock or damage to the electronics.

- ▶ **Switch off the appliance.**
- ▶ Pull out mains plug or switch off fuse.



## WARNING

Danger of fire

- ▶ Do not damage the refrigerant circuit.

- ▶ Empty the appliance.
- ▶ Pull out the power plug.
- ▶ Observe the notes on appliance transport. (see 4.3 Transporting the appliance)

## 8.3.2 Cleaning the housing

### NOTICE

Improper cleaning!  
Damage to the appliance.

- ▶ Only use soft cleaning cloths and ph-neutral all-purpose cleaners.
- ▶ Do not use steel wool or sponges that scour or scratch.
- ▶ Do not use caustic or abrasive cleaning materials or those containing sand, chloride, or acids.



## WARNING

Risk of injury or damage due to hot steam.  
Hot steam can cause scalding/burns and damage to surfaces.

- ▶ Do not use steam cleaners.

### NOTICE

Risk of damage due to short circuit.

- ▶ When cleaning the appliance, make sure no water gets into the electrical components.

- ▶ Wipe the housing down with soft, clean cloth. If very dirty, use lukewarm water with a neutral cleaner. Glass surfaces can also be cleaned with glass cleaner.
- ▶ Clean the condenser coil every year. If the condenser coil is not cleaned, this significantly reduces the efficiency of the appliance.

## 8.3.3 Cleaning fan cover

### NOTICE

Risk of damage due to short circuit.

- ▶ When cleaning the appliance, make sure no water gets into the electrical components.

### NOTICE

Improper cleaning!  
Damage to the appliance.

- ▶ Only use soft cleaning cloths and ph-neutral all-purpose cleaners.
- ▶ Do not use steel wool or sponges that scour or scratch.
- ▶ Do not use caustic or abrasive cleaning materials or those containing sand, chloride, or acids.

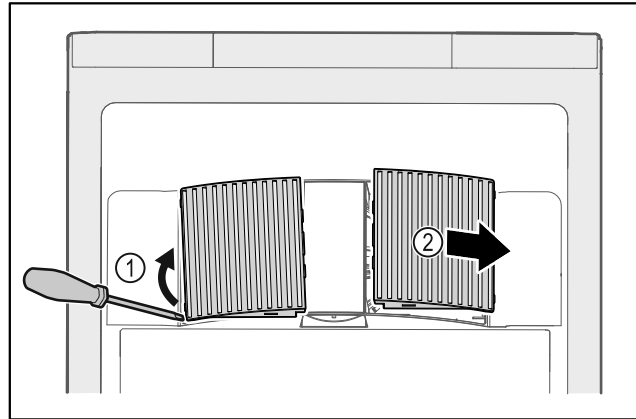

Fig. 164

- ▶ Carefully lever out fan covers from the side Fig. 164 (1) and remove towards the front Fig. 164 (2).
- ▶ Rinse the air slots of the fan covers under running water. If very dirty, use lukewarm water with a neutral cleaner.
- ▶ Leave fan covers to air-dry completely.
- ▶ Reattach fan covers to the appliance.

## 8.3.4 Cleaning the interior



## WARNING

Short-circuit hazard due to live parts!  
Electric shock or damage to the electronics.

- ▶ **Switch off the appliance.**
- ▶ Pull out mains plug or switch off fuse.



## WARNING

Risk of injury or damage due to hot steam.  
Hot steam can cause scalding/burns and damage to surfaces.

- ▶ Do not use steam cleaners.

### NOTICE

Improper cleaning!  
Damage to the appliance.

- ▶ Only use soft cleaning cloths and ph-neutral all-purpose cleaners.
- ▶ Do not use steel wool or sponges that scour or scratch.
- ▶ Do not use caustic or abrasive cleaning materials or those containing sand, chloride, or acids.

### Note

- ▶ Defrost water drain (see 1.2 Overview of appliance and equipment) : Remove deposits using a thin object (e.g. a cotton bud).

### Note

Do not damage or remove the type plate on the inside of the appliance. The type plate is important for Customer Service. (see 9.3 Customer Service)

## Customer support

- ▶ Open the door.
- ▶ Empty the appliance.
- ▶ Clean the interior and equipment parts with luke-warm water and a little dish detergent. Do not use any gritty or acidic cleaning agent or any chemical solvent.

### 8.3.5 After cleaning

- ▶ Wipe the appliance and equipment parts dry.
- ▶ Connect and switch on appliance.  
When the temperature is sufficiently cold:
- ▶ Place in items for refrigeration.
- ▶ Clean regularly.
- ▶ Clean and dust appliances with a heat exchanger (metal grill on rear of appliance) once per year.

## 9 Customer support

### 9.1 Technical data

Temperature range	
Cooling	+3 °C (38 °F) to +16 °C (60 °F)

Maximum load per shelf <sup>A)</sup>		
Appliance width	600 mm (23 1/2 in)	750 mm (29 7/16 in)
Grid shelves	45 kg (99.21 lb)	60 kg (132 lb)
Glass shelf	40 kg (88.18 lb)	40 kg (88.18 lb)
Wooden grid shelf	45 kg (99.21 lb)	60 kg (132 lb)
Drawer	50 kg (110 lb)	50 kg (110 lb)

A) Heavier loads may result in a slight bending of the shelves.

Maximum total load and net weight		
M o d e l (see 4.2 Appliance dimensions)	Maximum total load	Net weight
SRF. 3501	180 kg (397 lb)	60 kg (132 lb)
SRFfg 4001	225 kg (496 lb)	70 kg (154 lb)

Maximum total load and net weight		
M o d e l (see 4.2 Appliance dimensions)	Maximum total load	Net weight
SRF. 5501	300 kg (661 lb)	80 kg (176 lb)

Maximum net capacity	
See net capacity on the type plate. (see 1.2 Overview of appliance and equipment)	

Setup conditions	
Degrees of pollution (surrounding the appliance)	PD2
Ambient temperature	+10 °C (50 °F) to +35 °C (95 °F)
Maximum relative ambient moisture	75%, not condensing
Maximum operating elevation (meters above sea level)	2000 m (6,561.68 ft) 1500 m (4,921.26 ft) (glass door)

Electrical values	
Nominal voltage	115-127 V ~
Frequency	60 Hz
Connected load	2,0 A
Maximum power supply fluctuation	+/-10%
Overvoltage categories	II

### 9.2 Technical malfunction

Your appliance is designed and built to ensure it works reliably and has a long service life. If a malfunction nonetheless occurs during operation, please check whether the malfunction is due to an operating error. If this is the case, you will be charged for the cost incurred even if this falls within the warranty period.

You can rectify the following malfunctions yourself.

#### 9.2.1 Appliance function

Defect	Cause	Remedy
The appliance is not working.	The appliance is not switched on.	▶ Switch on the appliance.
	The power plug is not properly inserted in the socket.	▶ Check the power plug.

Defect	Cause	Remedy
	There is a problem with the wall socket breaker.	▶ Check the breaker.
	Power failure	▶ Keep the appliance closed. ▶ If necessary move the refrigerated/frozen items to another fridge or freezer if the power is off for a prolonged period.
	The IEC socket is not correctly plugged into the appliance.	▶ Check the IEC socket.
<b>The temperature is not cold enough.</b>	The appliance door is not closed properly.	▶ Close the appliance door.
	Ventilation is not sufficient.	▶ Unclog the ventilation grill and clean it.
	The ambient temperature is too high.	▶ Observe the suitable ambient conditions: (see 1.4 Range of appliance use)
	The appliance was opened too many times or for too long.	▶ Wait to see if the required temperature corrects itself. If not, contact Customer Service. (see 9.3 Customer Service)
	The temperature is set incorrectly.	▶ Set a colder temperature and check after 24 hours.
	The appliance is too close to a heat source (stove, heater etc).	▶ Move either the appliance or the heat source.

## 9.3 Customer Service

First check whether you can remedy the fault yourself. If this is not the case, please contact Customer Service.

You can find the address in the enclosed brochure "Liebherr-Service" or at [home.liebherr.com/service](http://home.liebherr.com/service).



### WARNING

Unprofessional repair!

Injuries.

- ▶ A damaged power cable may only be replaced by the manufacturer, the manufacturer's Customer Service or a similarly qualified person.
- ▶ For appliances with plug and play connection cables, the change can be made by the customer.

### 9.3.1 Contacting Customer Service

Make sure you have the following appliance information ready:

- Appliance name (model and index)
- Service no. (service)
- Serial no. (S no.)

- ▶ Access the appliance information via the display (see 6.2.15 Appliance information ).

-or-

- ▶ Refer to the type plate for appliance information. (see 9.4 Type plate)

- ▶ Note appliance information.
- ▶ Inform Customer Service: Report faults and the appliance information.
- ▷ This will help us to provide fast and focused service.
- ▶ Follow any further instructions provided by Customer Service.

## 9.4 Type plate

The type plate is inside the appliance. See appliance overview.

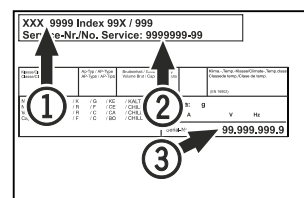

Fig. 165

- (1) Appliance designation
- (2) Service No.
- (3) Serial No.

## 10 Shutting down

- ▶ Empty the appliance.
- ▶ Switch off appliance.
- ▶ Pull the power plug from the outlet.

## Disposal

- ▶ If necessary, remove the IEC socket: Pull the IEC socket out of the appliance plug while turning it to the left and right at the same time.
- ▶ Clean the appliance. (see 8.3 Cleaning the appliance)
- ▶ If available: Remove the covers and insulation of the sensor feed-through to prevent mold from forming.
- ▶ Leave the door open so that no bad odors form.

### Note

Damage to the appliance and malfunctions!

- ▶ After shutting down, only store the appliance at the permitted room temperature of between -10 °C (14 °F) and +50 °C (122 °F).

## 11 Disposal

### 11.1 Preparing the appliance for disposal



#### WARNING

Risk of child entrapment!

Before you throw away your old refrigerator or freezer:

- ▶ Take off the doors.
- ▶ Leave the shelves in place so that children may not easily climb inside.



Li-Ion

Liebherr uses batteries in some of its appliances. You should remove these before disposal of the old appliance for environmental reasons. If your appliance contains batteries, a corresponding notice is attached to the appliance.

Lamps If you can remove the lamps yourself without destroying them, also remove these before disposal.

- ▶ Take the appliance out of operation.
- ▶ If possible: Remove lamps without destroying them.

### 11.2 Disposing of the appliance in an environmentally friendly manner



The appliance still contains valuable materials and must be collected separately from unsorted municipal waste so it can be recycled.



Dispose of batteries separately from the old appliance. Certain batteries should NOT go in household garbage or recycling bins. Waste batteries can always be recycled or taken to household hazardous waste collection points. To prevent fires from lithium-ion batteries, tape battery terminals and/or place batteries in separate plastic bags and never put these batteries in household garbage or recycling bins.

Lamps

Dispose of removed lamps via the respective collection systems.

For USA:

Check the Responsible Appliance Disposal (RAD) program to find a RAD partner near you.

For Canada:

Follow your local guidance about recycling and disposal capabilities near you.



#### WARNING

Leaking refrigerant and oil!

Fire. The refrigerant contained within the appliance is environmentally friendly, but flammable. The oil contained within the appliance is flammable. Escaping refrigerant and oil can ignite if they are of high enough concentration and are exposed to an external heat source.

- ▶ Do not damage the pipelines of the coolant circuit and the compressor.

- ▶ Observe the notes on appliance transport. (see 4.3 Transporting the appliance)
- ▶ Transport the appliance away without damaging it.
- ▶ Dispose of batteries, lamps, and the appliance according to the above specifications.

## 12 Additional information

Further information on warranty conditions can be found in the enclosed service brochure or on the Internet at <https://home.liebherr.com>.

Notify in event of  
appliance  
malfunction: \_\_\_\_\_

Model ID/  
Inventory number: \_\_\_\_\_

## Quick Start Guide for everyday use

### Information about using this Quick Start Guide:

- This Quick Start Guide is not a substitute for the full operating instructions nor is it a substitute for appliance training.
- This Quick Start Guide provides support for everyday use and handling the appliance.
- Read the full operating instructions and the safety instructions contained therein.

This quick start guide is for: SRFfg 35../55..



Using the QR code, you can read the full operating instructions.



## Status display



Fig. 166 Status display with actual temperature

## Displaying temperature recording

The temperature recording displays the length of the recording and the minimum and maximum temperatures measured during this period of time.



Fig. 167

## Intended use

This laboratory refrigerator, with an interior free of ignition sources, is suitable for professional storage of highly flammable products in closed containers, at temperatures between 3 °C (38 °F) and 16 °C (60 °F).

### Foreseeable incorrect use

Do not use the appliance for the following applications:

- Storage and cooling of:
  - Chemically unstable substances
  - Blood, plasma or other body fluids for the purpose of infusion, application or introduction in the human body
- Use in areas with risk of explosion
- Outdoor use or in areas where it is exposed to splash water or damp conditions

### When stocking, observe the following points:

- Position grid shelves according to the height required.
- Observe maximum load.
- When the storage temperature has been reached, load the appliance (compliance with cold chain).
- Keep the ventilation slots of the recirculation fan free in the interior.
- Items for refrigeration must not come into contact with the evaporator on the rear wall.
- Keep liquids in closed containers.
- Leave space when storing items for refrigeration to ensure adequate air circulation.

## Resetting temperature recording

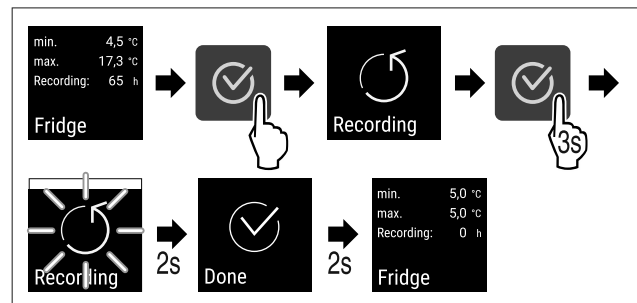

Fig. 168

## Unlocking appliance

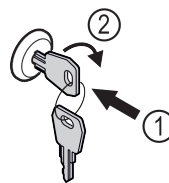

Fig. 169

- ▶ Insert the key. Fig. 169 (1)
- ▶ Turn the key clockwise by 90°. Fig. 169 (2)
- ▷ The appliance is unlocked.

# Quick Start Guide for everyday use

## Locking appliance

Cut out the page

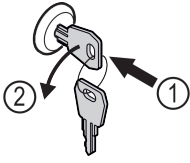

Fig. 170

- ▶ Insert the key. Fig. 170 (1)
- ▶ Turn the key anticlockwise by 90°. Fig. 170 (2)
- ▷ The appliance is locked.

## Cleaning appliance

- ▶ Empty the appliance.
- ▶ Pull out the power plug.
- ▶ Observe the information in the operating instructions.
- ▶ Dry the appliance and equipment thoroughly after cleaning.
- ▶ Connect the appliance.
- ▶ Switch on the appliance.
- ▶ Load the appliance once the storage temperature is reached.



## What should I do if there is a fault?

A message appears in the display if there is a fault. Messages have different meanings:

Symbol color in the display	Meaning	Remedy
<b>WHITE with black bar</b>	<b>Reminder</b> Reminder of general procedures. You can carry out these procedures to eliminate the message.	Consult the operating instructions and perform the troubleshooting steps.
<b>WHITE</b>	<b>Warning</b> Appears when there are malfunctions. You can eliminate simple malfunctions yourself.	Consult the operating instructions and perform the troubleshooting steps.
If you cannot remedy the fault yourself, contact a competent member of staff or your nearest customer service outlet.		





[home.liebherr.com/fridge-manuals](https://home.liebherr.com/fridge-manuals)

**EN** ORIGINAL OPERATOR'S MANUAL

Issue date: 20240911

**Part number index: 7082908-00**

For service in the United States and Canada: Liebherr Service Center  
Toll Free: 1-844-542-6782  
Email: [service-commercial.us@liebherr.com](mailto:service-commercial.us@liebherr.com)  
PlusOne Solutions, Inc.  
3501 Quadrangle Blvd, Suite 120  
Orlando, FL 32817

