

Piling and drilling rig

LRB 355.1

EN-US

LRB 2504.07

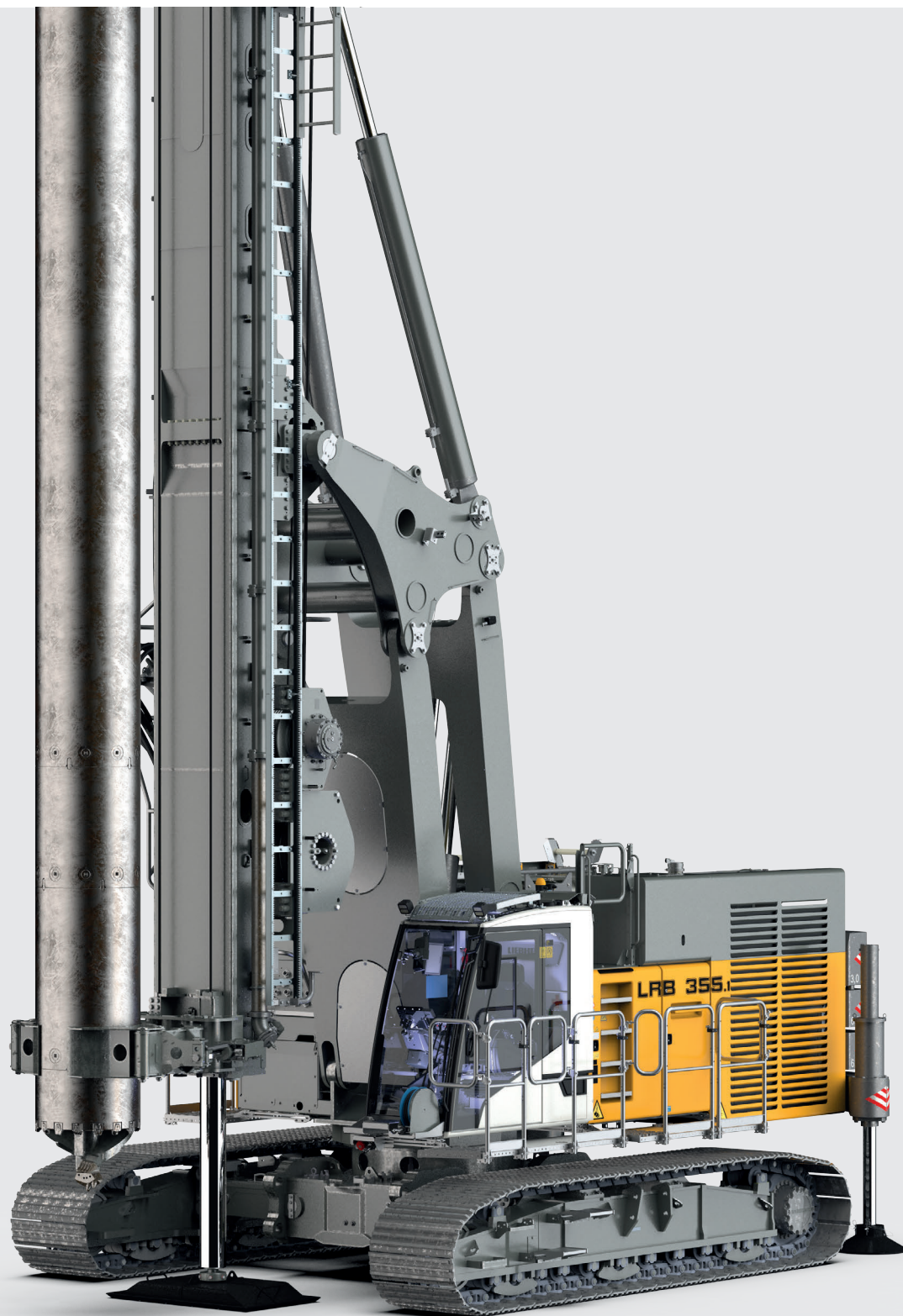

LIEBHERR

Concept and characteristics

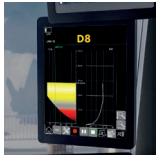

PDE[®]
Process Data Recording

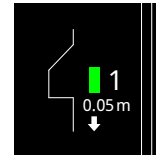

Kelly
Visualization



MyJobsite



Ground
Pressure
Visualization



LIPOS[®]
Positioning System



Radio remote
control



LiDAT[®]
Data Transmission



Concrete
pump



The robust universal machine for a wide variety of applications:

- Full displacement drilling
- Continuous flight auger drilling
- Double rotary drilling
- Kelly drilling
- Soil mixing
- Vibrator slim design
- Ring vibrator
- Hydraulic hammer

Assistance systems:

- Cruise Control for all main functions
- Joystick control for all machine functions
- Automatic shake-off function for working tools
- Kelly Visualization
- Ground Pressure Visualization
- Radio remote control for concrete pump
- Drilling assistant (single-pass process)
- Leader inclination memory
- Display of auger filling level
- Kelly winch with freewheeling and with slack rope monitoring and prevention

Technical data



Diesel engine

Power rating according to ISO 9249	600 kW (805 hp) at 1700 rpm 750 kW (1005 hp) at 1700 rpm
Engine type	Liebherr D 9512 A7-04
Fuel tank capacity	343 gal with continuous level indicator and reserve warning
Exhaust emission	complies with EU 2016/1628 Stage V or NRMM exhaust certification EPA/CARB Tier 4f



Hydraulic system

Hydraulic pumps	
for attachments	3x 105 + 2x 114 gal/min
for kinematics	57 gal/min
Hydraulic oil tank capacity	291 gal
Max. working pressure	5,801 PSI
Hydraulic oil	A system of electronically monitored pressure and return filters cleans the hydraulic oil. Any clogging is displayed in the cabin. The use of synthetic environmentally friendly oil is also possible.



Crawlers

Drive system	with fixed axial piston hydraulic motors
Crawlers	maintenance-free, with hydraulic chain tensioning device
Brake	hydraulically released multi-disc holding brake
Undercarriage type 225	
Drive speed	0-1.3 mph
Track force	145,451 lbf
Grousers	3-web grousers, width 35.4 inch
Undercarriage type 260	
Drive speed	0-1.1 mph
Track force	167,483 lbf
Grousers	3-web grousers, width 39.4 inch



Swing gear

Drive system	with fixed axial piston hydraulic motors, planetary gearbox, pinion
Swing ring	triple-row roller bearing with external teeth and 2 swing drives
Brake	hydraulically released multi-disc holding brake
Swing speed	0-2.4 rpm continuously variable



Winches

Kelly winch with free fall	
Line pull effective	56,202 lbf (1 st layer)
Rope diameter	34 mm
Rope speed	0-279 ft/min
Optional 66,139 lbs Kelly winch with free fall*	
Line pull effective	67,443 lbf (1 st layer)
Rope diameter	34 mm
Rope speed	0-262 ft/min
* max. line pull only available in the operating mode Kelly drilling	
Auxiliary winch	
Line pull effective	17,985 lbf (3 rd layer)
Swing range	left 180°, right 90°
Radius adjustment device	8 ft
Rope diameter	20 mm
Rope speed	0-177 ft/min



Crowd system

Crowd system	
Crowd winch	
Crowd force	89,924 / 89,924 lbf (push/pull)
Line pull effective	44,962 lbf
Travel with 72.2 ft leader	60.7 ft
Travel with 88.6 ft leader	77.1 ft
Rope speed	0-230 ft/min
Optional free fall for hammer operation	



Noise emission / vibration

Noise emission		according to 2000/14/EC directive
Emission sound pressure level L_{PA}	75 dB(A)	(in the cabin)
Guaranteed sound power level L_{WA}	110 dB(A)	(of the machine)
Vibration transmitted to the machine operator	< 8.2 ft/s ²	(to the hand-arm system)
Optional Eco-Silent Mode	< 1.6 ft/s ²	(to the whole body)
Guaranteed sound power level L_{WA}	-3 dB(A)	(of the machine)

Remarks:

- Illustrations showing the types of application (e.g. Kelly drilling, continuous flight auger drilling etc.) are examples only.
- Weights can vary with the final configuration of the machine. The figures in this brochure may include options which are not within the standard scope of supply of the machine.

Dimensions

Leader 72.2 ft

Leader 88.6 ft

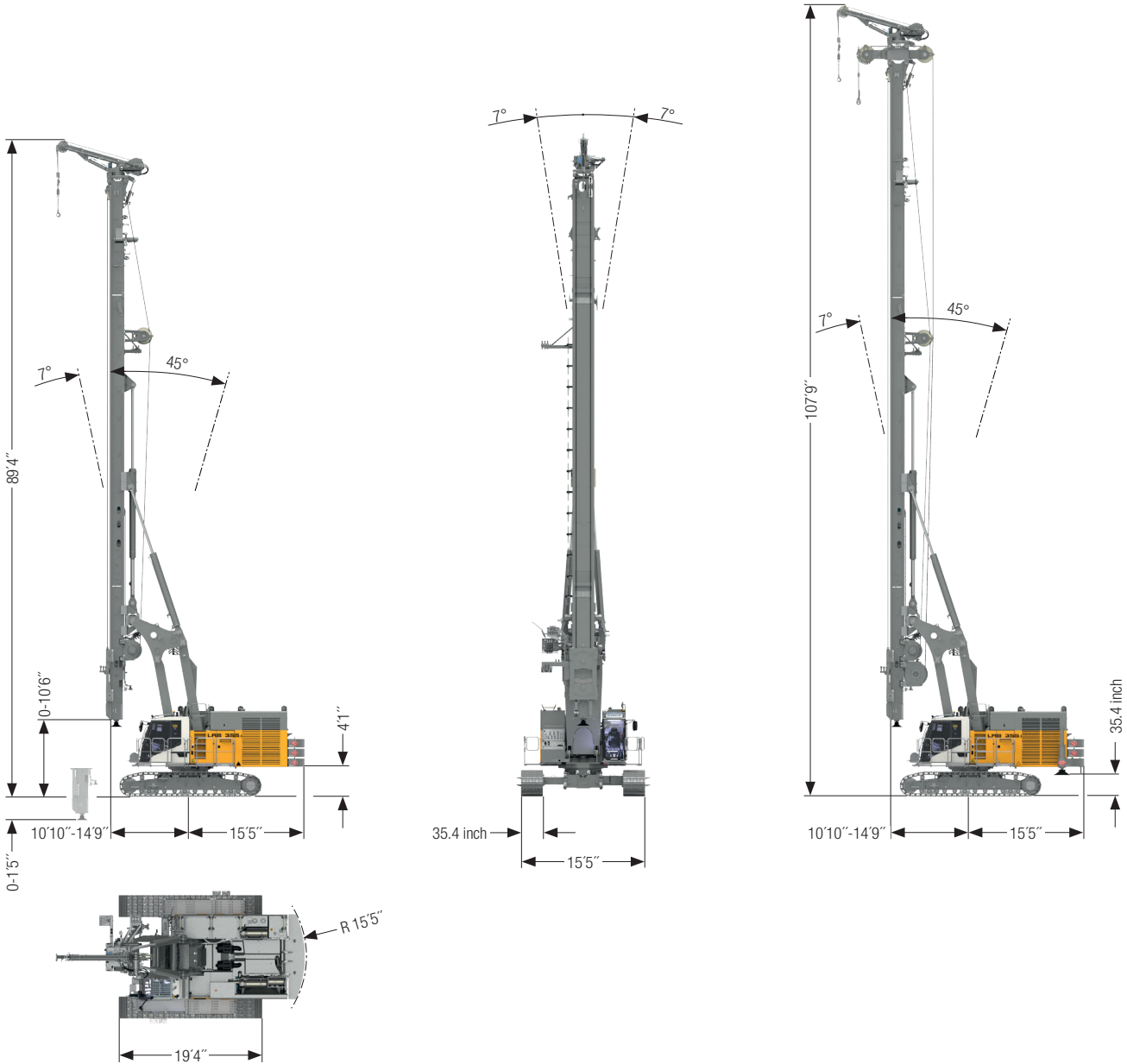

Operating weight

Total weight with undercarriage type 225	lbs	210,762
--	-----	---------

The operating weight includes the basic machine LRB 355.1 (ready for operation – including 20% filling of diesel tank) and 3x 13,228 lbs counterweight, without attachment and Kelly equipment.

Operating weight

Total weight with undercarriage type 225	lbs	224,210
--	-----	---------

The operating weight includes the basic machine LRB 355.1 (ready for operation – including 20% filling of diesel tank) with Kelly equipment and 3x 13,228 lbs counterweight, without attachment.

Leader 88.6 ft

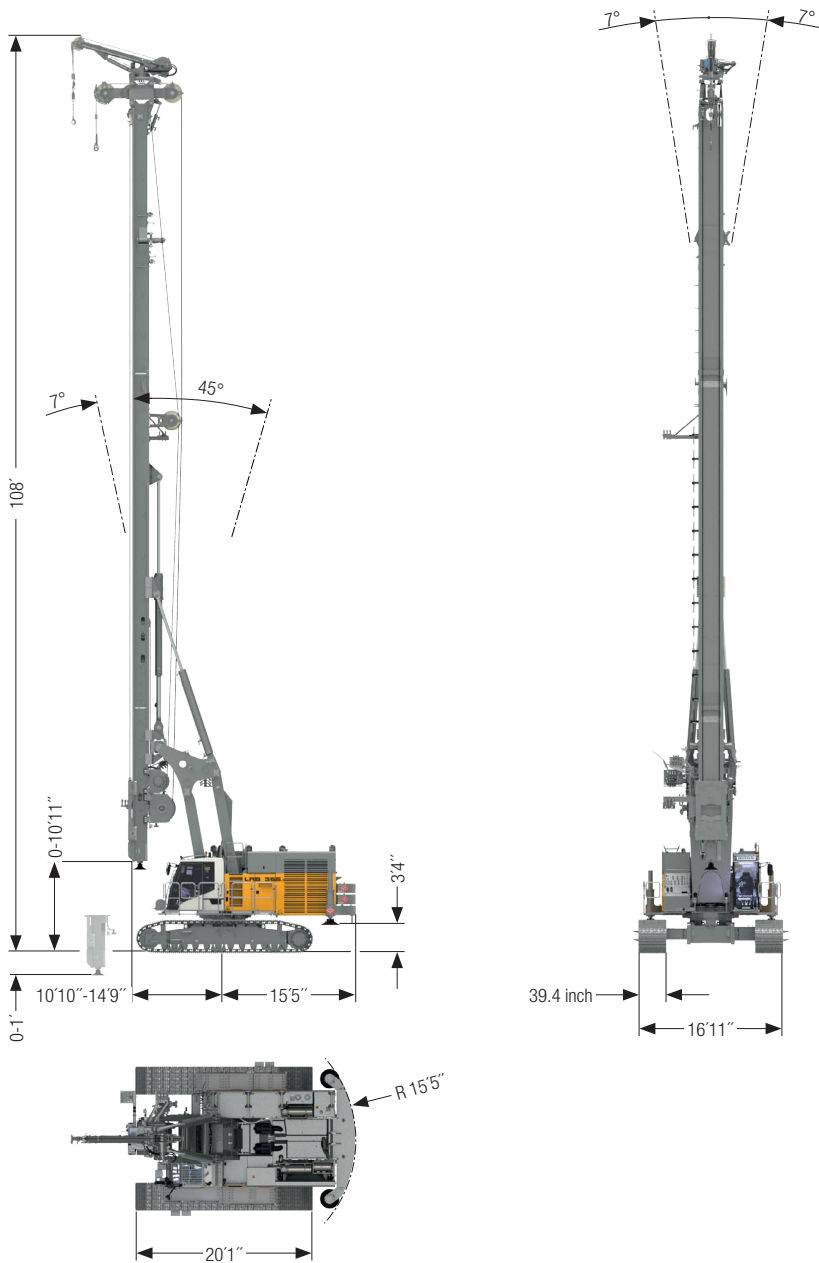

Operating weight

Total weight with undercarriage type 260	lbs	239,863
--	-----	---------

The operating weight includes the basic machine LRB 355.1 (ready for operation – including 20 % filling of diesel tank) with Kelly equipment and 3x 13,228 lbs counterweight, without attachment.

Transport and weights

Undercarriage type 225

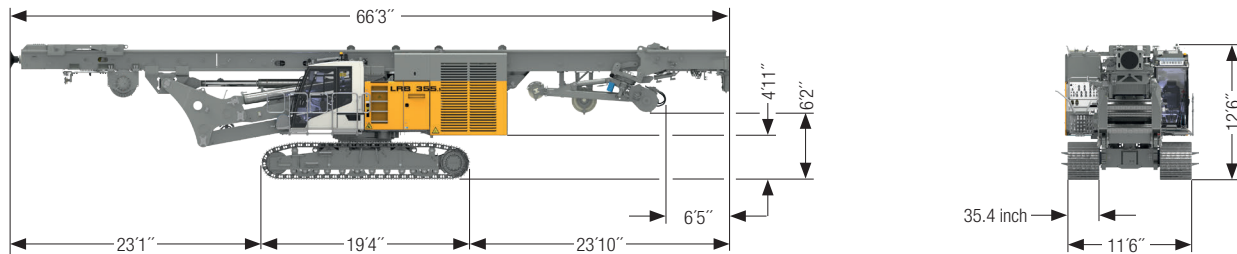

Leader 72.2 ft without Kelly equipment

includes the basic machine LRB 355.1 (ready for operation – including 20% filling of diesel tank) without counterweight and attachment.

lbs 171,079

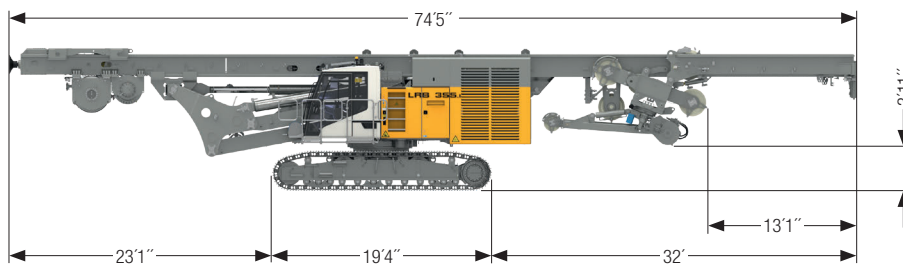

Leader 88.6 ft with Kelly equipment

includes the basic machine LRB 355.1 (ready for operation – including 20% filling of diesel tank) without counterweight and attachment.

lbs 184,527

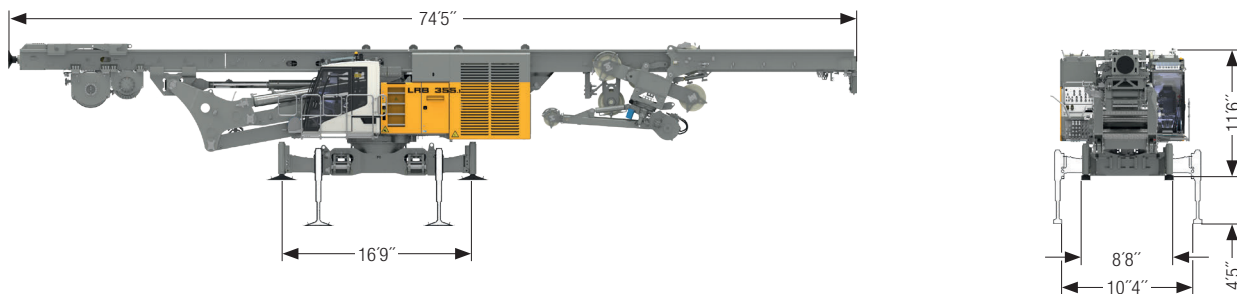

Leader 27 m with Kelly equipment, without crawlers, with jack-up system

includes the basic machine LRB 355.1 (ready for operation – including 20% filling of diesel tank) with jack-up system and adapter for casing oscillator, without counterweight and attachment.

lbs 161,158

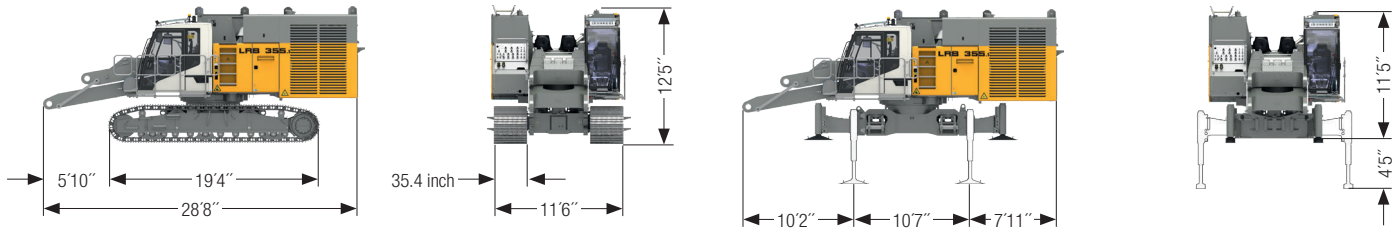

Basic machine versions

without jack-up system, counterweight and adapter for casing oscillator	lbs	107,365
with jack-up system and adapter for casing oscillator, without counterweight and crawlers	lbs	83,996

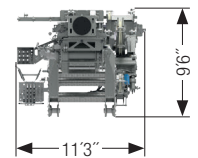
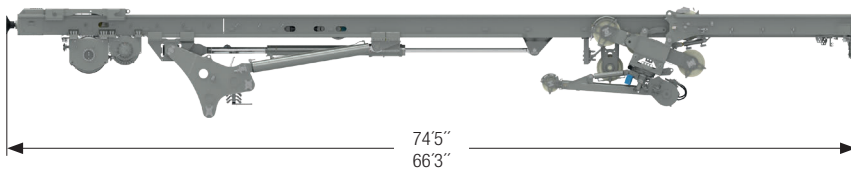

Leader

Leader 72.2 ft without Kelly equipment	lbs	63,714
Leader 88.6 ft with Kelly equipment	lbs	77,162

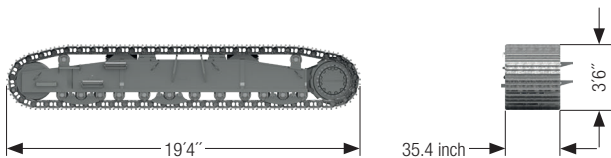

Crawler type 225

Weight	lbs	16,314
--------	-----	--------

Undercarriage type 260

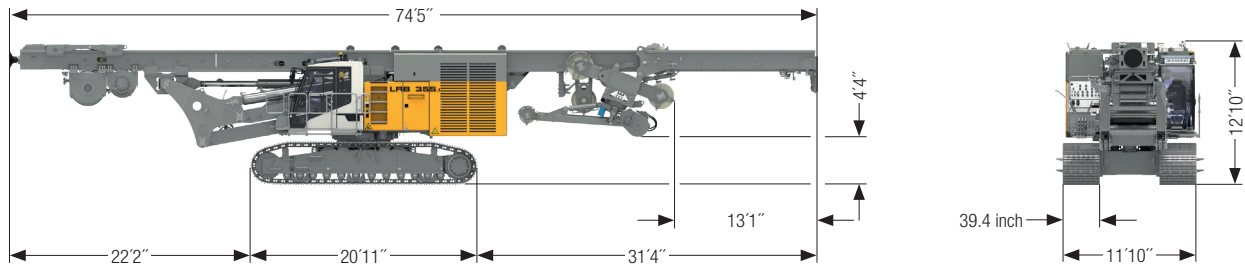

Leader 88.6 ft with Kelly equipment

includes the basic machine LRB 355.1 (ready for operation – including 20 % filling of diesel tank), without counterweight and attachments. lbs 199,959

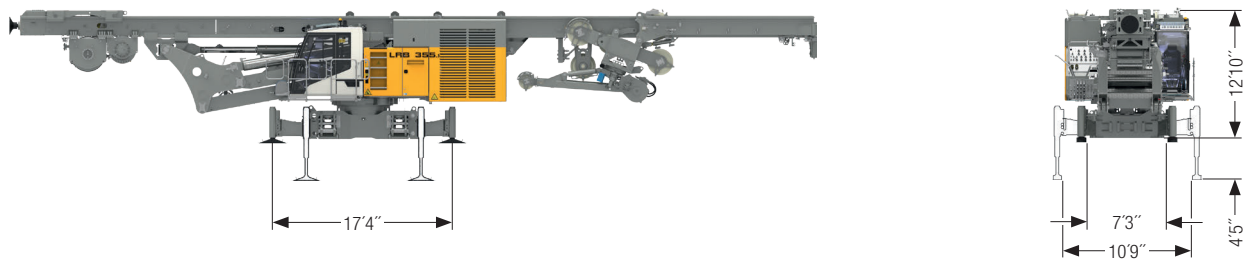

Leader 88.6 ft with Kelly equipment, without crawlers, with jack-up system

includes the basic machine LRB 355.1 (ready for operation – including 20 % filling of diesel tank) with jack-up system and adapter for casing oscillator, without counterweight and attachment. lbs 164,024

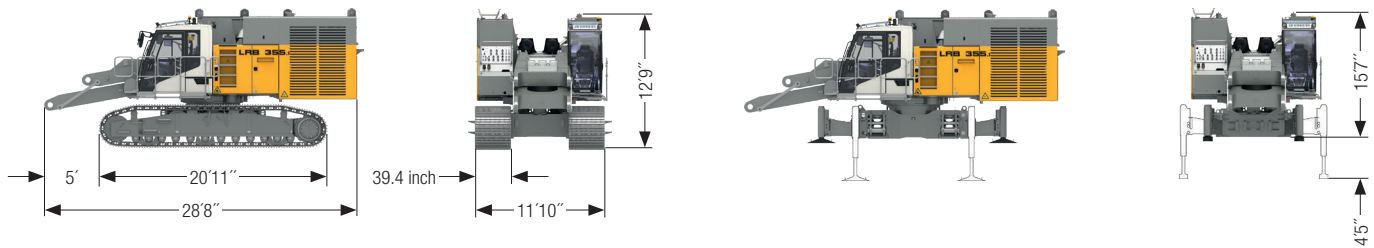

Basic machine versions

without jack-up system, counterweight and adapter for casing oscillator.	lbs	122,797
with jack-up system and adapter for casing oscillator, without counterweight and crawlers.	lbs	86,862

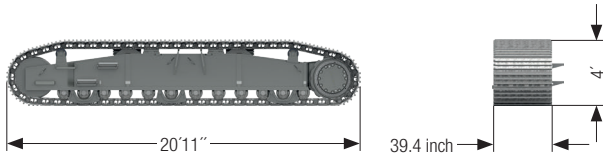

Crawler type 260

Weight	lbs	22,707
--------	-----	--------

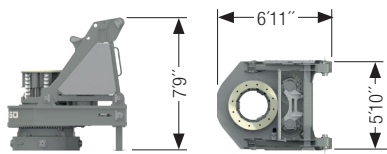

BAT 450.1

Weight	lbs	19,842
--------	-----	--------

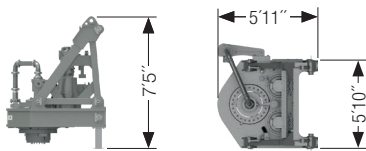

MA 220

Weight	lbs	14,110
--------	-----	--------

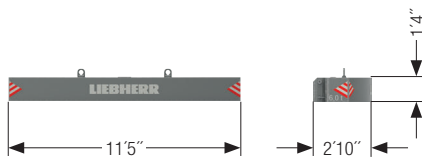

Counterweight (standard)

Weight	lbs	3x 13,228
--------	-----	-----------

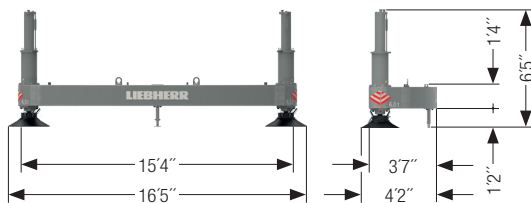

Counterweight (option)

Weight	lbs	1x 13,228
--------	-----	-----------

Options

Adapter for casing oscillator	lbs	2,866
Jack-up system (incl. adapter for casing oscillator)	lbs	8,598
Elevating working platform	lbs	1,102
Concrete supply line	lbs	1,764

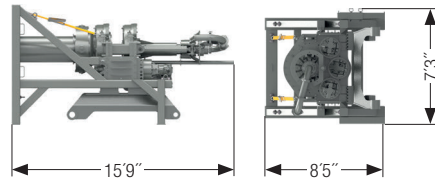

DBA 300

Weight	lbs	26,015
--------	-----	--------

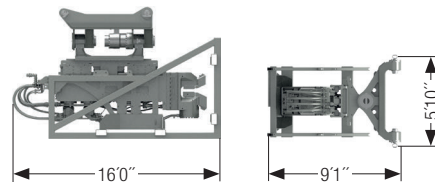

Vibrator slim design LV 36

Weight	lbs	27,999
--------	-----	--------

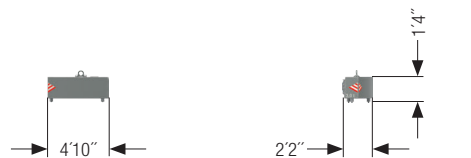

Additional counterweight (option, only for double rotary drilling)

Weight	lbs	2x 13,228
--------	-----	-----------

Full displacement drilling

BAT 450.1

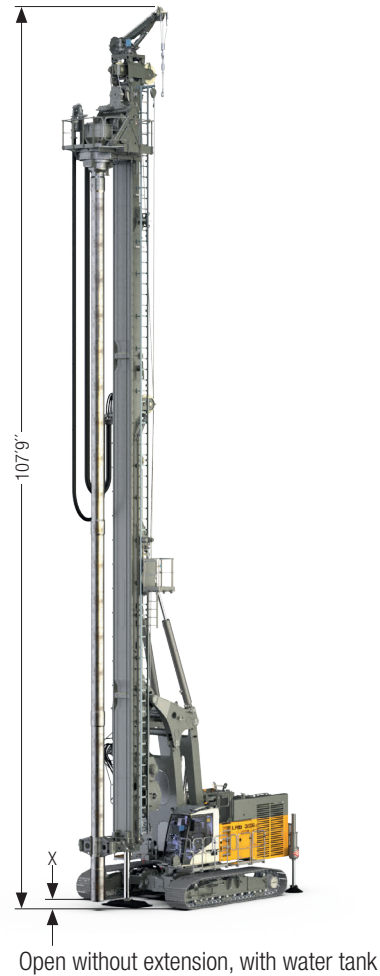
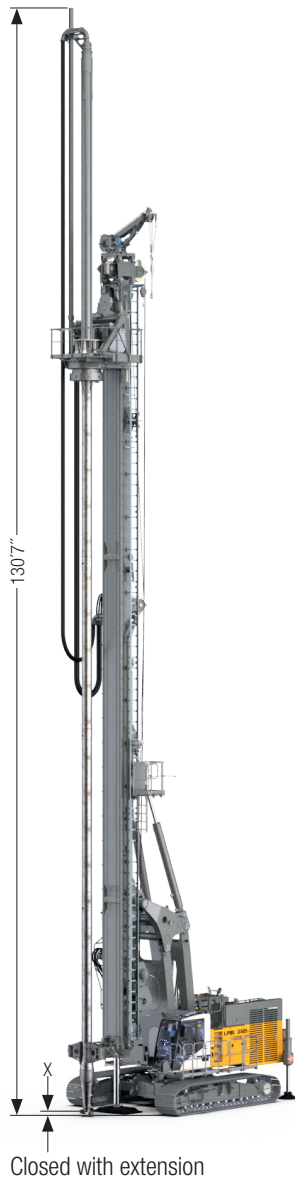

Performance data

Rotary drive - torque	lbf-ft	331,903
Rotary drive - speed	rpm	38
Max. drilling depth	ft	84.6
Drilling depth with 32.8 ft Kelly extension	ft	117.5
Max. pull force (crowd winch and Kelly winch)	lbf	202,328
Max. drilling diameter*	inch	23.6

Above drilling depths are valid for the use of standard tools and for the X value of 22.8 inch shown in the illustration.

Using the 72.2 ft leader the given maximum drilling depth must be reduced by 16.4 ft.

* Other drilling diameters available on request

Continuous flight auger drilling

BAT 450.1

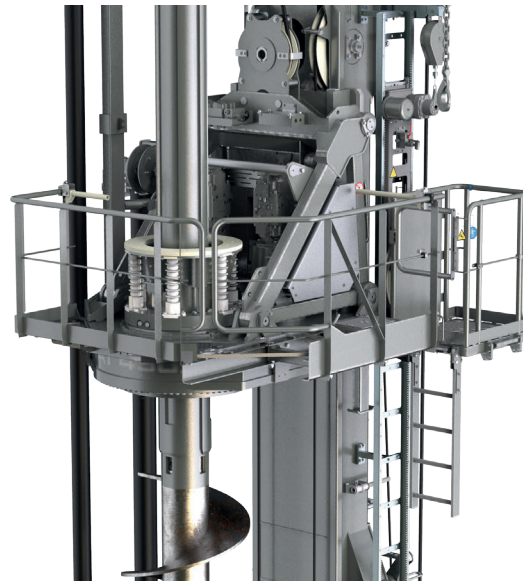
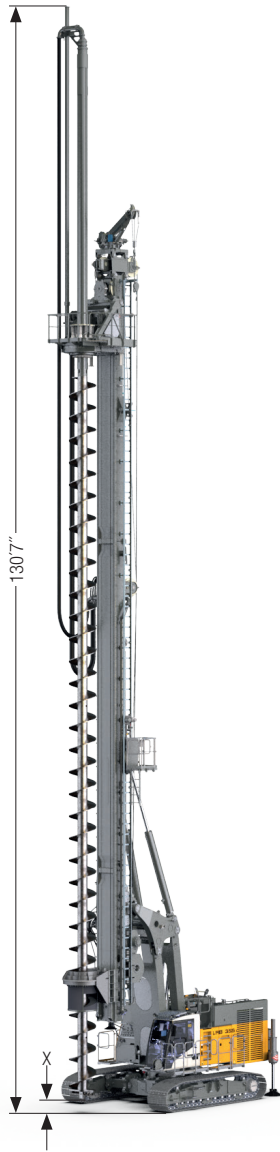

Detailed view of BAT 450.1

Performance data

Rotary drive - torque	lbf-ft	331,903
Rotary drive - speed	rpm	38
Max. drilling depth	ft	83.7
Drilling depth with 32.8 ft Kelly extension	ft	116.5
Max. pull force (crowd winch and Kelly winch)	lbf	202,328
Max. drilling diameter*	inch	47.2

Above drilling depths take into account that an auger cleaner is used and the cardan joint has been removed.

Above drilling depths are valid for the use of standard tools and for the X value of 13.8 inch shown in the illustration.

Using the 72.2 ft leader the given maximum drilling depth must be reduced by 16.4 ft

*Other drilling diameters available on request

Double rotary drilling

DBA 300



Performance data

Rotary drive I - torque	lbf-ft	0-221,267
Rotary drive I - speed	rpm	0-26
Rotary drive II - torque	lbf-ft	0-110,634
Rotary drive II - speed	rpm	0-30
Max. drilling diameter*	inch	35.40
Max. pull force (crowd winch and Kelly winch) <small>single fall</small>	lbf	146,126
Max. pull force (crowd winch and Kelly winch) <small>two fall***</small>	lbf	202,328
Max. drilling depth**	ft	85.3

Above drilling depths are valid for the use of standard tools and for an X value of 11.8 inch.

Using the 72.2 ft leader the given maximum drilling depth must be reduced by 16.4 ft. Due to differences in the max. admissible load capacities, the combinations of drilling depth and drilling diameter may be limited.

* Other drilling diameters available on request

** When using a protective hose, the maximum drilling depth must be reduced by 31.5 inch

*** When using a two-fall pulling device, the maximum drilling depth must be reduced by 8.2 ft

Kelly drilling

BAT 450.1

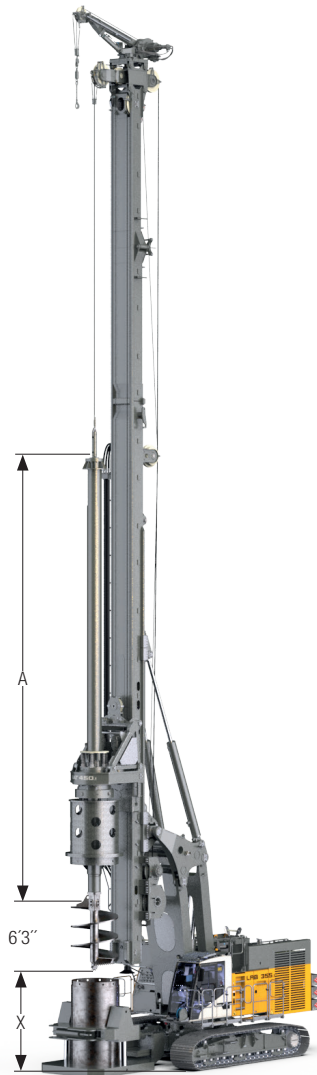

Performance data

Rotary drive - torque	lbf-ft	331,903
Rotary drive - speed	rpm	38
Max. drilling diameter uncased	ft	6.6
Max. drilling diameter* cased	ft	4.9
Max. drilling diameter below the leader	ft	14.4

Other drilling diameters available on request.

When using a casing oscillator, value X must be reduced by 63 inch.

*Depends on the design of the casing driver

Kelly bars

	A	X**	Drilling depth	Weight
	ft	ft	ft	lbs
MD 36/3/30	39.0	48.6	88.6	16,755
MD 36/3/36	45.6	42.0	108.3	20,283
MD 36/4/30	32.6	55.1	88.6	18,740
MD 36/4/42	42.5	45.3	128.3	24,030
MD 36/4/48	49.0	40.4	148.0	26,676
MD 36/4/54	52.3	35.4	167.7	28,660
MD 36/4/60	57.3	30.5	187.3	31,085
MD 36/4/66	62.2	25.6	207.0	33,731

** Values valid for 88.6 ft leader. For machines with 72.2 ft leader value X is reduced by 16.4 ft

Soil mixing

3MA 100

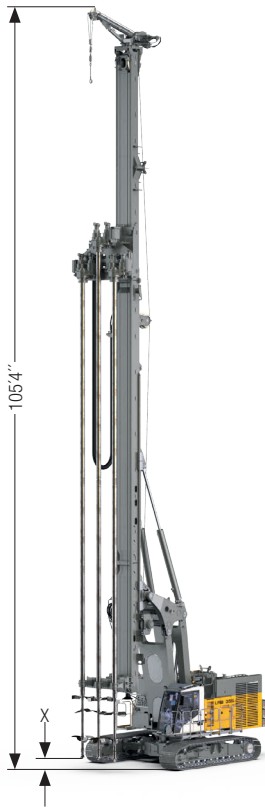

MA 220

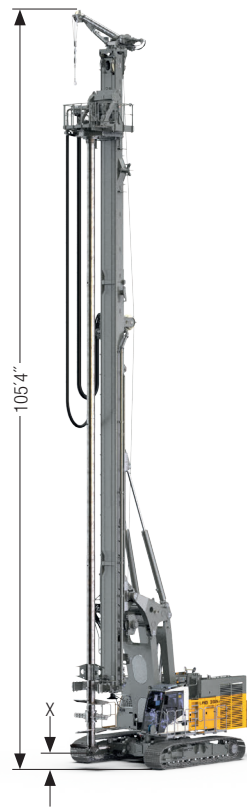

BAT 450.1

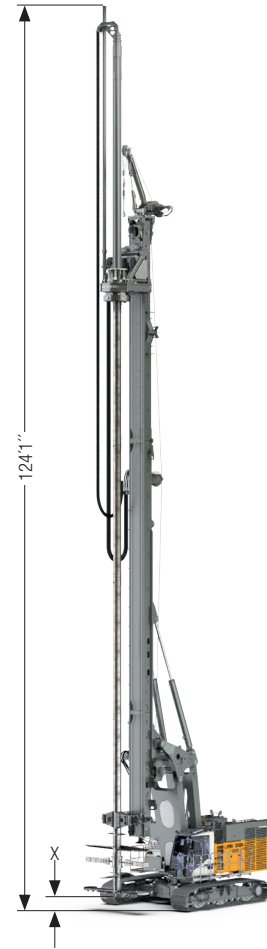

Performance data 3MA 100

Rotary drive - torque	lbf-ft	0-78,182
Rotary drive - speed	rpm	0-75
Swing range mixing drive	°	+/- 30
Centre-to-centre distance adjustable in steps of 0.2ft	ft	2-2.6
Max. mixing depth	ft	85.3
Max. pull force	lbf	146,126

Above mixing depth is valid for the use of standard tools and for the X value of 1 ft shown in the illustration.

Performance data MA 220

Rotary drive - torque	lbf-ft	162,264
Rotary drive - speed	rpm	80
Max. mixing depth	ft	85.3
Max. mixing diameter*	ft	4.9

Above mixing depth is valid for the use of standard tools and for the X value of 11.8 inch shown in the illustration.

*Other mixing diameters available on request

Performance data BAT 450.1

Rotary drive - torque	lbf-ft	331,903
Rotary drive - speed	rpm	38
Max. mixing depth	ft	84
Mixing depth with 32.8 ft Kelly extension	ft	116.8
Max. mixing diameter*	ft	11.1

Above mixing depth is valid for the use of standard tools and for the X value of 29.9 inch shown in the illustration.

*If the mixing diameter is 6.6 ft or more the mixing paddle is always located below the leader, other diameters available on request

Using the 72.2 ft leader the given maximum mixing depths must be reduced by 16.4 ft.

Vibrator slim design

LV 36

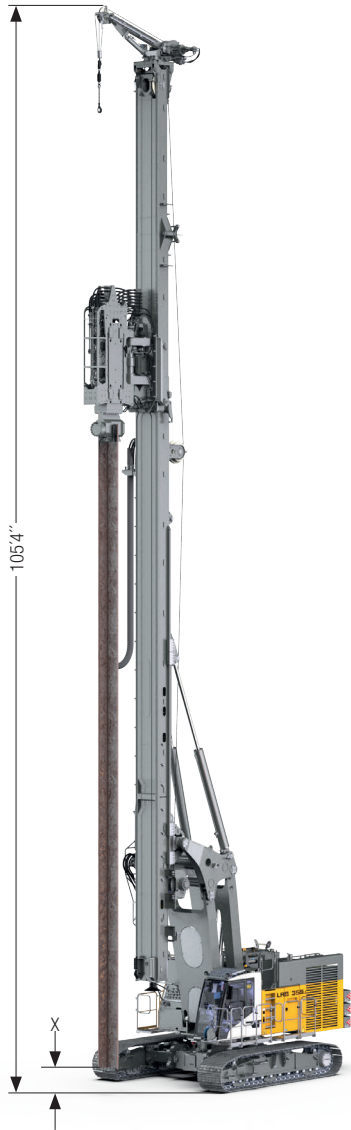

Performance data

Static moment	lbs-ft	0-260
Max. frequency	rpm	0-2200
Max. pull force	lbf	429,385
Total weight without clamp	lbs	21,021
Dynamic weight with clamp	lbs	13,889
Max. pile element length	ft	86.9
Swing range vibrator	°	-87 / +80

The given pile element length is valid for the X value of 1.6 ft shown in the illustration.

Using the 72.2 ft leader the given maximum pile element length must be reduced by 16.4 ft.

Ring vibrator

32 VMR



Performance data

Static moment	lbf-ft	0-23,602
Max. frequency	rpm	2300
Max. pull force	lbf	418,144
Pile element diameter	inch	22-24
Max. pile element length	ft	131.2
Total weight	lbs	30,644

Using the 72.2 ft leader the given maximum pile element length must be reduced by 16.4 ft.

Hydraulic hammer

H 15L

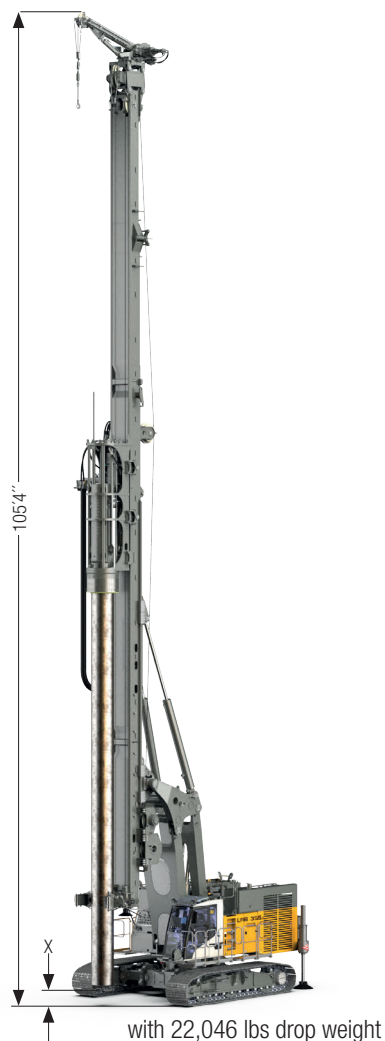

Performance data

Drop weight	lbs	22,046
Max. rated energy	lbf-ft	110,634
Blow rate max. energy	blows/min	30
Max. blow rate	blows/min	80
Kelly winch (pile winch)	lbf	56,202
Total weight	lbs	39,992
Max. pile length	ft	80.4

The given pile element length is valid for the X value of 19.7 inch shown in the illustration.
Using the 72.2 ft leader the given maximum pile element length must be reduced by 16.4 ft.

BAT 450.1

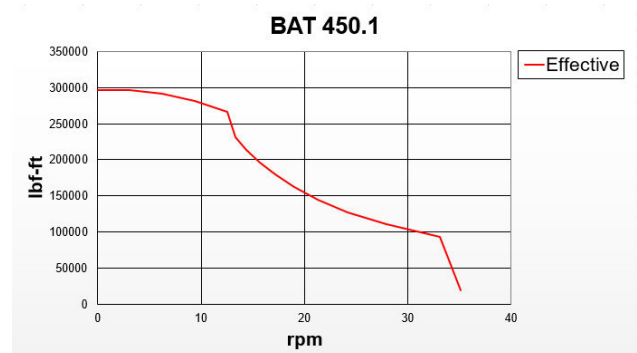
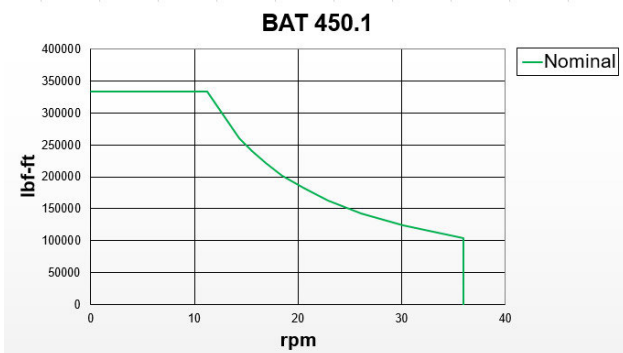
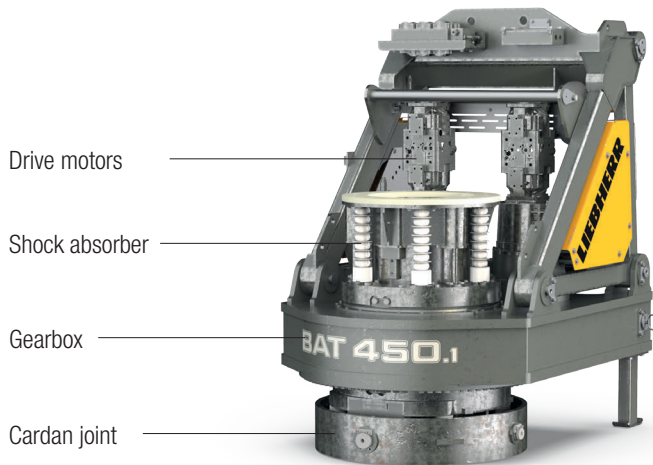

Kelly shock absorber:

- Newly developed Kelly shock absorber for highest demands
- Possibility of adjusting the strength of the Kelly shock absorber for different Kelly bar weights

Automatic gearbox for best operating comfort:

- No stopping required to change gears
- No interruption of the drilling process
- Continuous optimization of speed

Highest availability through easy set-up:

- No mechanical shift gearbox
- Low maintenance requirements

Flexibility through modular design:

- Exchangeable cardan joint for other casing drivers
- Exchangeable drive adapters for use of other Kelly bars
- Quickly exchangeable equipment for other methods of operation

Ground Pressure Visualization

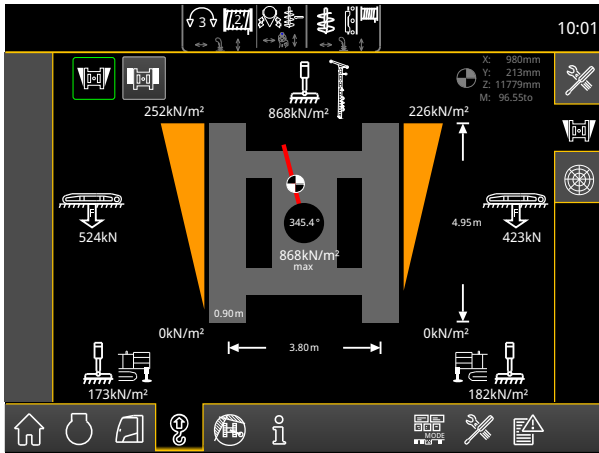

Features:

- The actual ground pressure is calculated in real time
- The maximum admissible ground pressure can be individually predefined
- The utilization is continuously calculated and displayed on the monitor in the operator's cab
- Audible and visual warnings when the predefined values are approached

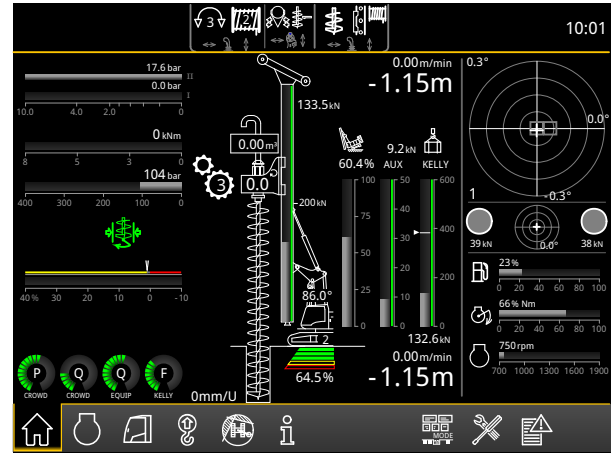

Your benefits:

- Increased safety on the jobsite due to consideration of prevailing ground conditions.
- Higher operator comfort thanks to clearly displayed information and warning signal
- Prevention of critical or stressful situations before they occur
- User-friendly and intuitive handling in the operator's cab

Kelly Visualization

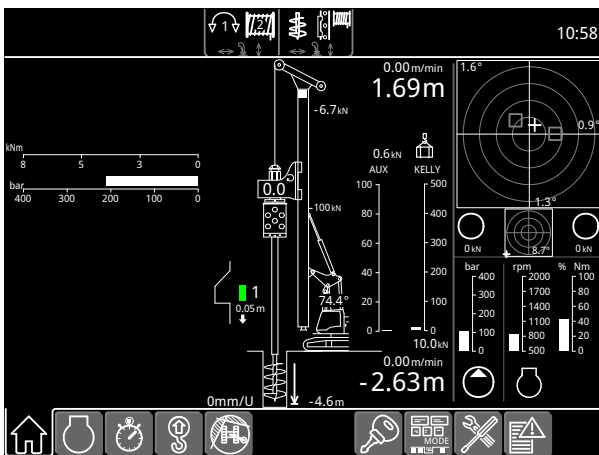

Your benefit:

- Time saving: The operator no longer needs to search for the interlocking recesses
- Higher availability: The machine needs less repair and maintenance work
- More safety: Correct locking prevents damage to the Kelly bar
- Cost reduction: Smooth operation results in higher performance and less wear

all measurements displayed on this page are metric

The Liebherr Group of Companies

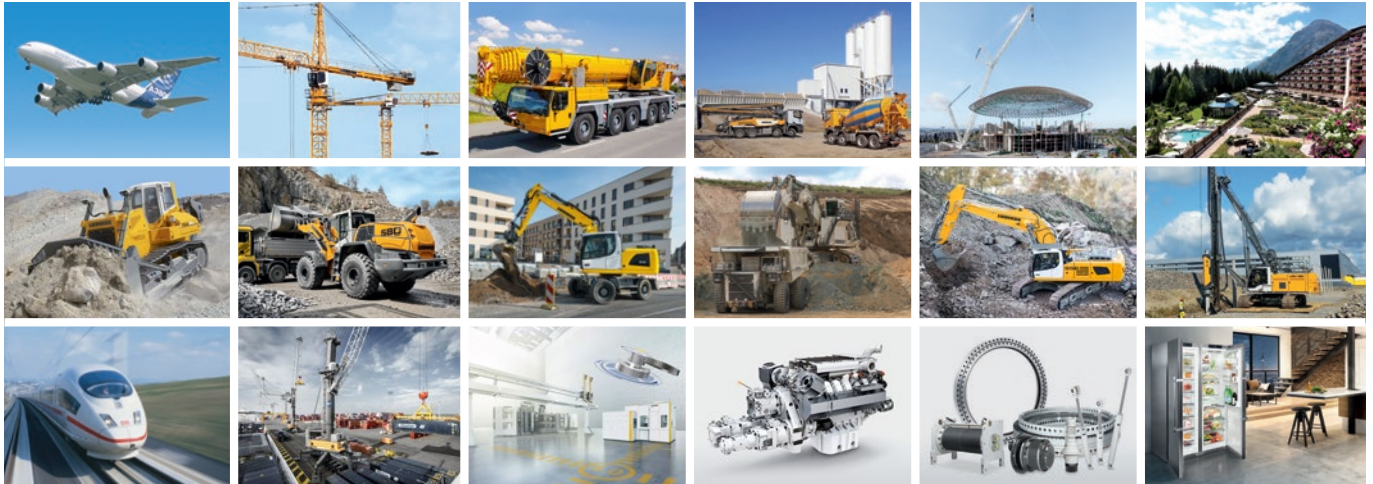

Wide Product Range

The Liebherr Group is one of the largest construction equipment manufacturers in the world. Liebherr's high-value products and services enjoy a high reputation in many other fields. The wide range includes domestic appliances, aerospace and transportation systems, machine tools and maritime cranes.

Exceptional Customer Benefit

Every product line provides a complete range of models in many different versions. With both their technical excellence and acknowledged quality, Liebherr products offer a maximum of customer benefits in practical applications.

State-of-the-art Technology

To provide consistent, top quality products, Liebherr attaches great importance to each product area, its components and core technologies. Important modules and components are developed and manufactured in-house, for instance the entire drive and control technology for construction equipment.

Worldwide and Independent

Hans Liebherr founded the Liebherr family company in 1949. Since then, the family business has steadily grown to a group of more than 130 companies with nearly 44,000 employees located on all continents. The corporate headquarters of the Group is Liebherr-International AG in Bulle, Switzerland. The Liebherr family is the sole owner of the company.

www.liebherr.com

Liebherr-Werk Nenzing GmbH

Dr. Hans Liebherr Str. 1, 6710 Nenzing/Austria

+43 50809 41-473

www.liebherr.com, foundation.equipment@liebherr.com

[facebook.com/LiebherrConstruction](https://www.facebook.com/LiebherrConstruction)