

L 509 Tele

Product information

LIEBHERR

Telescopic wheel loader



Generation
6

Tipping load
3,600–3,800 kg

Diesel engine
Stage V

Max. payload for fork carrier and fork
2,300 kg¹⁾

**Max. lifting height for fork carrier
and fork**
4,800 mm

¹⁾ Recommended payload for smooth surfaces
= 80% of tipping load, articulated –
according to 474-3

Equipped for all heights



Tipping load

3,800 kg

Bucket capacity

0.9 m³

Operating weight

7,000 kg

Max. payload for fork carrier and fork

2,300 kg¹⁾

Max. lifting height for fork carrier and fork

4,800 mm

Engine output

54 kW / 73 HP

¹⁾ Recommended payload for smooth surfaces = 80% of tipping load, articulated – according to 474-3

Performance

- Specially designed telescopic lift arms enable high manipulation heights up to 4.8 m and long reach
- In addition to classic wheel loader operation, also specifically designed with industrial use in mind
- Excellent manoeuvrability thanks to Liebherr stereo steering (combination of articulated steering and steered rear axle)
- Powerful Telescopic linkage offer extremely precise parallel guidance in fork operation without manual re-adjustment
- Efficient equipment change via hydraulic quick coupler increases machine utilisation
- Reduced articulation angle (30°) creates a central machine centre of gravity and increased stability

Economy

- Compact design enables excellent handling performance even in confined spaces
- Continuous acceleration without noticeable gear changes and loss of traction thanks to the powerful Liebherr hydrostatic travel drive
- 38 km/h top speed (standard) ensures very high productivity
- Fuel and cost savings thanks to intelligent cooling system with cooling control corresponding to demand
- Efficient cooling performance through cooling air flowing across the entire engine compartment
- Cooling air is drawn in from the side behind the operator's cab
- Reduced cleaning time and consistent, reliable cooling performance thanks to the intelligent cooling system

Reliability

- Long lifetime thanks to strong steel construction and components perfectly coordinated with one another
- Intelligent overload warning system provides constant information about the load situation and stability of the machine with the help of the integrated load torque limit and the load torque indicator
- Shortly before reaching the stability limit in the forward tipping direction, the movements of the working hydraulics slow down to a standstill
- Automatic visual and audible warning system when the maximum lifting load is exceeded, increases safety when moving heavy loads

Comfort

- Clearly and ergonomically arranged controls in the operator's cab enable focussed and fatigue-free work
- Precise and sensitive control of the machine by means of a control lever with mini-joystick integrated in the operator's seat as standard
- Large glass panes, roof screen and the specially designed telescopic lift arms provide excellent all-round visibility in all lift arm positions
- Perfect all-round visibility thanks to the design of the engine bonnet which optimises visibility and the optionally available reversing camera
- Damped articulated pendulum joint guarantees excellent stability and maximum driving comfort
- Automatic bucket return-to-dig, programmable auto lifting and lowering, and visualisation of the equipment position on the display with the optional 'Tele comfort operation' package

Maintainability

- The key points for daily maintenance are easily accessible from ground level
- Entire engine compartment easily accessible with only one hood to open
- High machine availability due to minimal service work
- Quick and safe checks save time and money

Focus on safety and comfort

Lift arms

Powerful and clever – the intelligently designed telescopic lift arms with the powerful Telescopic linkage impress with high payloads at maximum reach and lifting height. Safe lifting and loading without the need for manual re-adjustment and no loss of load enables quick positioning of the load. The optimised parallel movement in fork operation over the entire lifting range ensures the safe transportation of loads.



Stable and tip resistant

Stable and safe – the stereo steering with an articulation angle of 30° offers maximum manoeuvrability due to the tight turning radius and also maximum stability and resistance to tipping over. Compensation for uneven ground is undetectable due to the integrated articulated pendulum joint, which achieves comfortable and stable driving characteristics. The ideal ratio of operating mass to tipping load enables large payloads and thus maximum productivity.



Operator's cab

Visibility in any direction – large glass surfaces, roof screen and the visibility-optimised cab and engine bonnet design ensure an optimum view of the operating area. The optional reversing camera offers the operator a better view of the rear area of the wheel loader at a glance and increases safety in everyday work. In addition to the significant space available, there is the impressive well-ordered cockpit with clear view. A special feature is the height-adjustable 9-inch touch screen which clearly displays all information. The hydraulic quick coupler enables convenient changing of the working tool directly from the cab.

Technology

Intuitive and intelligent – the logical arrangement of control elements enables convenient handling which is easy get acquainted with. Precise and safe operation of all work and drive travel functions can be carried out with just one control lever, promoting economical and versatile work. The highly efficient hydrostatic travel drive promotes fast and productive work due to the increased travel speed of 38 km/h.

Technical data



Diesel engine

Diesel engine	4TNV98CT	
Design	Water-cooled turbocharged in-series diesel engine	
Cylinder inline	4	
Fuel injection process	Electronic Common Rail high-pressure injection	
Output to ISO 9249 - SAE J1349	kW / HP at RPM	52 / 71 2,400
Rated output to ISO 14396 / ECE-R.120	kW / HP at RPM	54 / 73 2,400
Nominal speed	2,400	
Max. torque to ISO 14396	Nm at RPM	280 1,800
Displacement	litres 3.32	
Bore / Stroke	mm 98 / 110	
Stage V		
Harmful emissions values	According to regulation (EU) 2016/1628	
Emission control	Closed diesel particle filter system	
Air cleaner system	Dry type filter with main and safety element	
Electrical system		
Operating voltage	V	12
Capacity	Ah	100
Alternator	V / A	12 / 80
Starter	V / kW	12 / 3

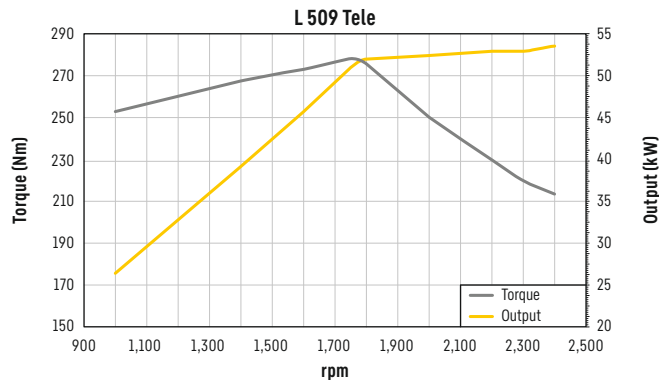

Driveline

Hydrostatic driveline – Speeder	
Design	2-speed automated gearbox, swash plate type variable flow pump and variable axial piston motor in closed loop circuit
Filtration	Suction return line filter for closed circuit
Control	By travel and inching pedal. The inching pedal makes it possible to control the tractive and thrust forces steplessly at full engine speed. The Liebherr control lever is used to control forward and reverse travel
Travel speed range	Speed range 1 _____ 0–18 km/h Speed range 2 _____ 0–38 km/h* forward and reverse Speeds quoted apply with the tyres indicated as standard on loader model.

* Configuration, tyres and mounting tools can influence the maximum speed.

Axles

Four-wheel drive	
Front axle	Fixed
Rear axle	Axle pivot steering, fixed
Height of obstacles which can be driven over	mm 370 with all four wheels remaining in contact with the ground
Differentials	100% differential lock in front axle, manually engaged
Reduction gear	Planetary final drive in wheel hubs
Track width	1,630 mm with tyres indicated as standard

Brakes

Service brake	Wear-free service brake due to hydrostatic driveline, applied to all four wheels and additional dual-circuit brake system, drum brake and wet multi-disc brake located in the front axle
Parking brake	Negative brake system in the front axle acting on the wet multi-disc brakes

The braking system meets the requirements of the ISO 3450.

Steering

Design	Stereo steering system, hydraulic servo power steering. Central oscillating frame articulation with damper element in combination with rear-axle pivot steering
Angle of articulation	30° to each side
Angle of oscillation - centre-pivot steering	8° to each side
Max. pressure	bar 180

Attachment hydraulics

Design	Gear pump to supply the hydraulic and steering systems (via priority valve)
Cooling	Hydraulic oil cooling using thermostatically controlled fan
Filtration	Suction return line filter in the hydraulic reservoir
Control	Liebherr control lever, electro-proportionally operated, 1st and 2nd additional hydraulic function electro-proportionally controlled optional
Lifting function	Lifting, neutral, lowering Float position controlled by Liebherr control lever with detent, automatic lift arm position and lowering by Liebherr control lever optional
Tilt function	Tilt back, neutral, dump Automatic bucket return for tilting back and dumping controlled by Liebherr control lever optional
Telescope	Telescoping extension and retraction controlled electro-proportionally operated by mini-joystick, stroke limit damping
Max. flow	l/min. 93
Max. pressure	bar 230

Attachment

Geometry	Telescopic lift arm with powerful Telescopic linkage, hydraulic quick hitch as standard
Cycle time at nominal load	TK
Lifting	s 5.2
Dumping	s 2.0
Lowering (empty)	s 4.0
Extend	s 4.0
Retract	s 3.0

Operator's cab

Design	Elastic mounted, noise-proof cab ROPS roll over protection per EN ISO 3471 / EN 474-1 FOPS falling objects protection per EN ISO 3449 / EN 474-1, Cat. II Operator's door with 180° opening angle with rigid window, fold-out window on right with 12° gap opener or 180° opening, roof glass panel, roof glass panel windscreen wiper optional, single-pane safety glass ESG, heated rear window ESG, all windows are tinted. Continuously adjustable steering column optional
Liebherr operator's seat	5 way adjustable, vibration-damped operator's seat "Standard" (mechanically sprung, adjustable to operator's weight), Liebherr control lever mounted into the operator's seat as standard
Cab heating and ventilation	Fresh / recirculated air mode, cab heating via cooling water, arrangement of the air nozzles ensures quick defrosting and defogging of the windows, electrically heated rear window
Vibration emissions	
Vibrations in the hand/arm	ft/s ² ≤ 2.5
Vibrations through the whole body	ft/s ² ≤ 0.5

Sound level

Sound pressure level to ISO 6396		
L _{PA} (inside cab)	dB(A)	73
Sound power level to 2000/14/EC		
L _{WA} (surround noise)	dB(A)	101

Capacities

Fuel tank	l 90
Engine oil (inclusive filter change)	l 10.2
Travel gear / rear axle	l 1.3
Coolant	l 9
Front axle / differential	l 6.8
Rear axle / differential	l 6
Front axle / wheel hubs	l 1.4
Rear axle / wheel hubs	l 1.4
Hydraulic tank	l 65
Hydraulic system, total	l 110

Dimensions

Telescopic linkage

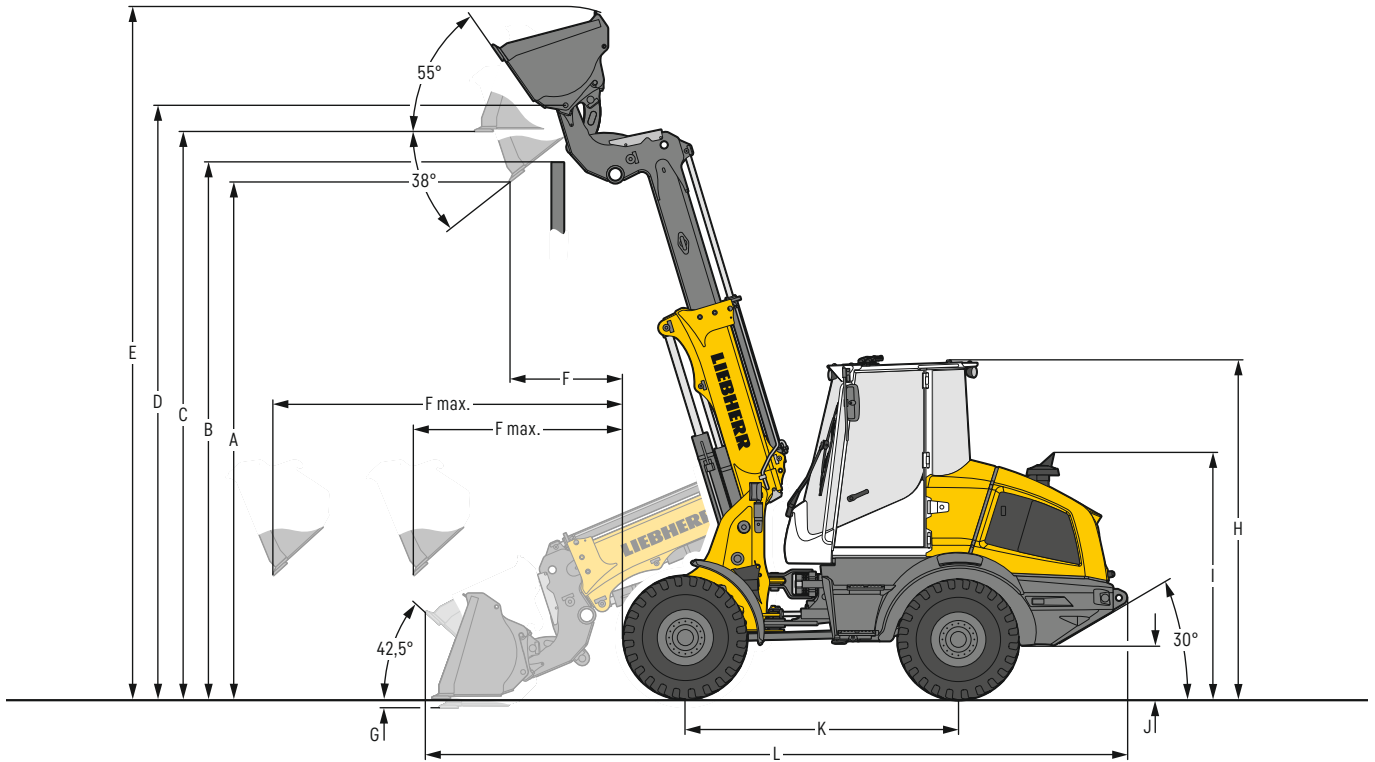

Excavation bucket

Geometry		TK-QH
Cutting tools		BOCE
Lift arm length	mm	2,475 / 3,650
Bucket capacity according to ISO 7546 **	m ³	0.9
Specific material density	t/m ³	1.8
Bucket width	mm	2,200
A Dumping height at max. lift height and 40° discharge	mm	4,320
B Dump-over height	mm	4,500
C Max. height of bucket bottom	mm	4,760
D Max. height of bucket pivot point	mm	4,960
E Max. operating height	mm	5,790
F Reach at max. lift height and 40° discharge	mm	950
F max. Max. reach at 42° discharge	mm	1,750 / 2,930
G Digging depth	mm	90
H Height above operator's cab ¹⁾	mm	2,790
I Height above exhaust	mm	2,020
J Ground clearance	mm	305
K Wheelbase	mm	2,300
L Overall length	mm	5,835
Turning circle radius over tyres	mm	3,760
Turning circle radius over outside bucket edge	mm	4,225
Breakout force (SAE)	kN	49
Tipping load, straight *	kg	4,300
Tipping load, fully articulated *	kg	3,800
Operating weight *	kg	7,000
Tyre size		400/70R20 L3

* The figures shown include the above tyres, all lubricants, a full fuel tank, the ROPS / FOPS cab and the operator. Different tyres and optional equipment will change the operating weight and tipping load. (Tipping load, fully articulated according to ISO 14397-1).

** Actual bucket capacity may be approx. 10% larger than the calculation according to ISO 7546 standard. The degree to which the bucket can be filled depends on the material – see page 11.

¹⁾ Available option of "roof glass panel windscreen wiper" the value "H" increases to 50 mm.

TK-QH = Telescopic linkage incl. quick hitch

BOCE = Bolt-on cutting edge

Attachment

Light material bucket

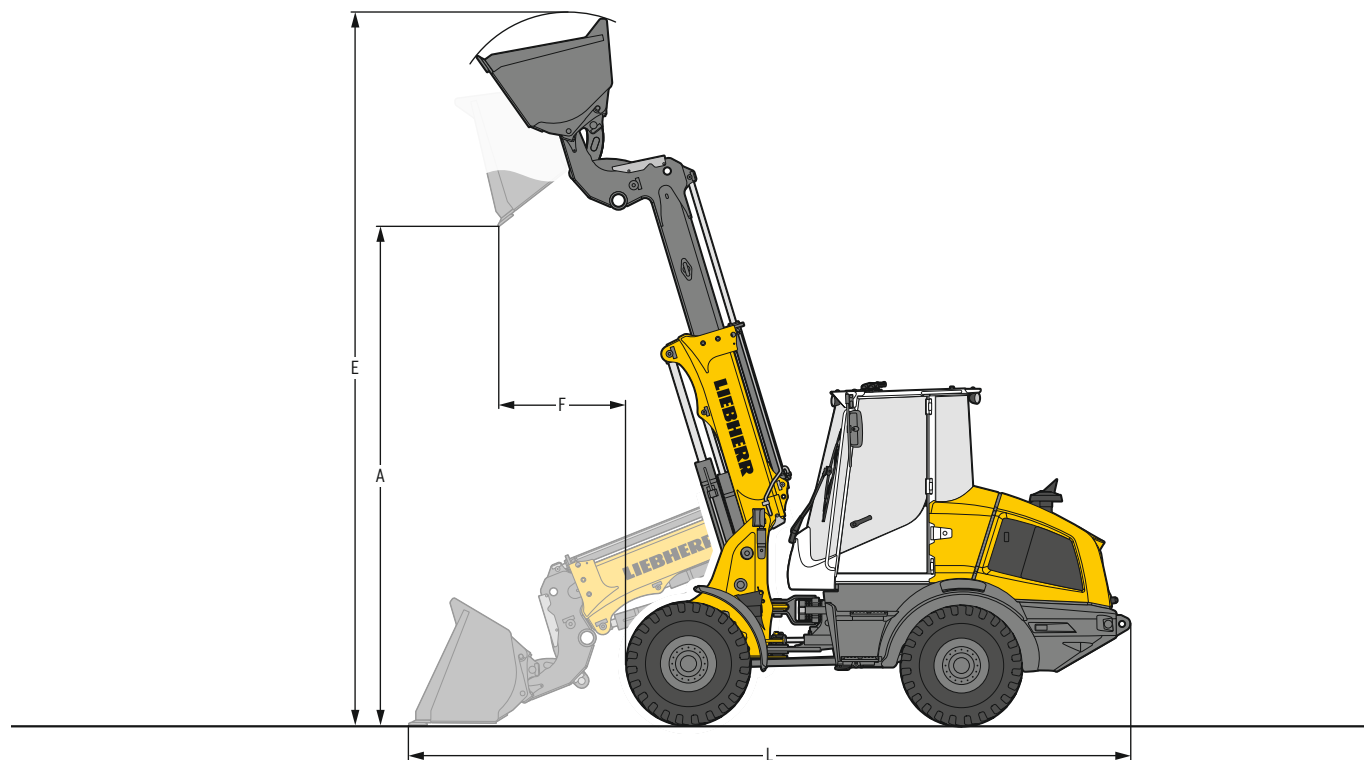

Heavy material density

Geometry		TK-QH	TK-QH
Cutting tools		BOCE	BOCE
Bucket capacity	m ³	1.6	2.0
Specific material density	t/m ³	1.0	0.8
Bucket width	mm	2,400	2,400
A Dumping height at max. lift height	mm	4,165	4,085
E Max. operating height	mm	5,790	5,950
F Reach at maximum lift height	mm	1,055	1,170
L Overall length	mm	6,050	6,195
Tipping load, straight*	kg	4,100	4,050
Tipping load, fully articulated*	kg	3,650	3,600
Operating weight*	kg	7,100	7,150
Tyre size		400/70R20 L3	

* The figures shown include the above tyres, all lubricants, a full fuel tank, the ROPS / FOPS cab and the operator. Different tyres and optional equipment will change the operating weight and tipping load. (Tipping load, fully articulated according to ISO 14397-1).

TK-QH = Telescopic linkage incl. quick hitch
BOCE = Bolt-on cutting edge

Attachment

4 in 1 bucket

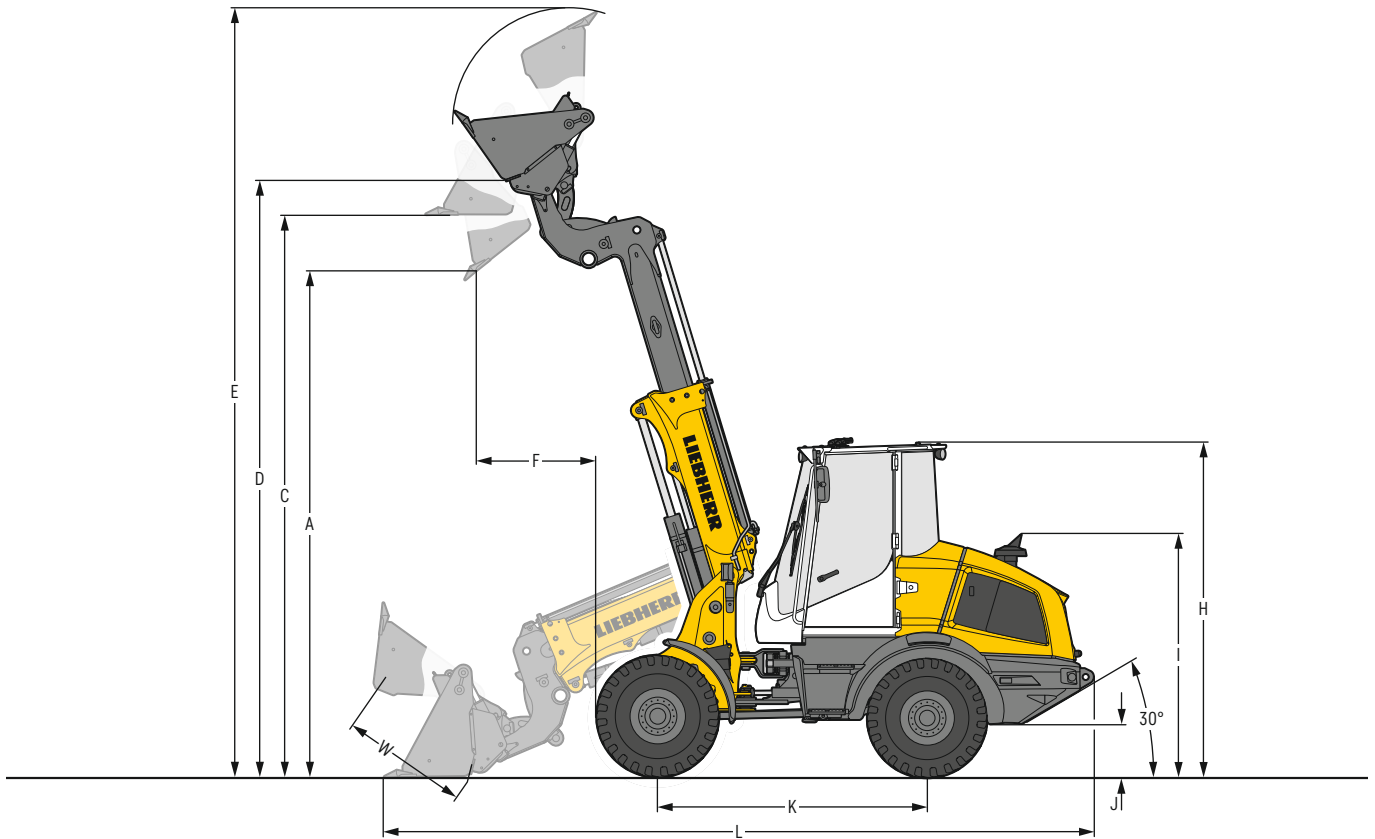

4 in 1 bucket

		STD
Geometry		TK-QH
Cutting tools		T
Bucket capacity	m ³	0.8
Specific material density	t/m ³	1.8
Bucket width	mm	2,100
A Dumping height at max. lift height and 42° discharge	mm	4,280
A1 Max. dumping height with opened bucket	mm	5,050
C Max. height of bucket bottom	mm	4,770
E Max. operating height	mm	6,510
F Reach at max. lift height and 42° discharge	mm	1,030
L Overall length	mm	6,040
W Max. bucket opening	mm	960
Turning circle radius over outside bucket edge	mm	3,995
Tipping load, straight*	kg	4,110
Tipping load, fully articulated*	kg	3,650
Operating weight*	kg	7,120
Tyre size		405/70R20

* The figures shown include the above tyres, all lubricants, a full fuel tank, the ROPS/FOPS cab and the operator. Different tyres and optional equipment will change the operating weight and tipping load. (Tipping load, fully articulated according to ISO 14397-1)

STD = Standard lift arm length

TK-QH = Telescopic linkage incl. quick hitch

T = Welded-on tooth holder with add-on teeth

Attachment

Fork carrier and fork

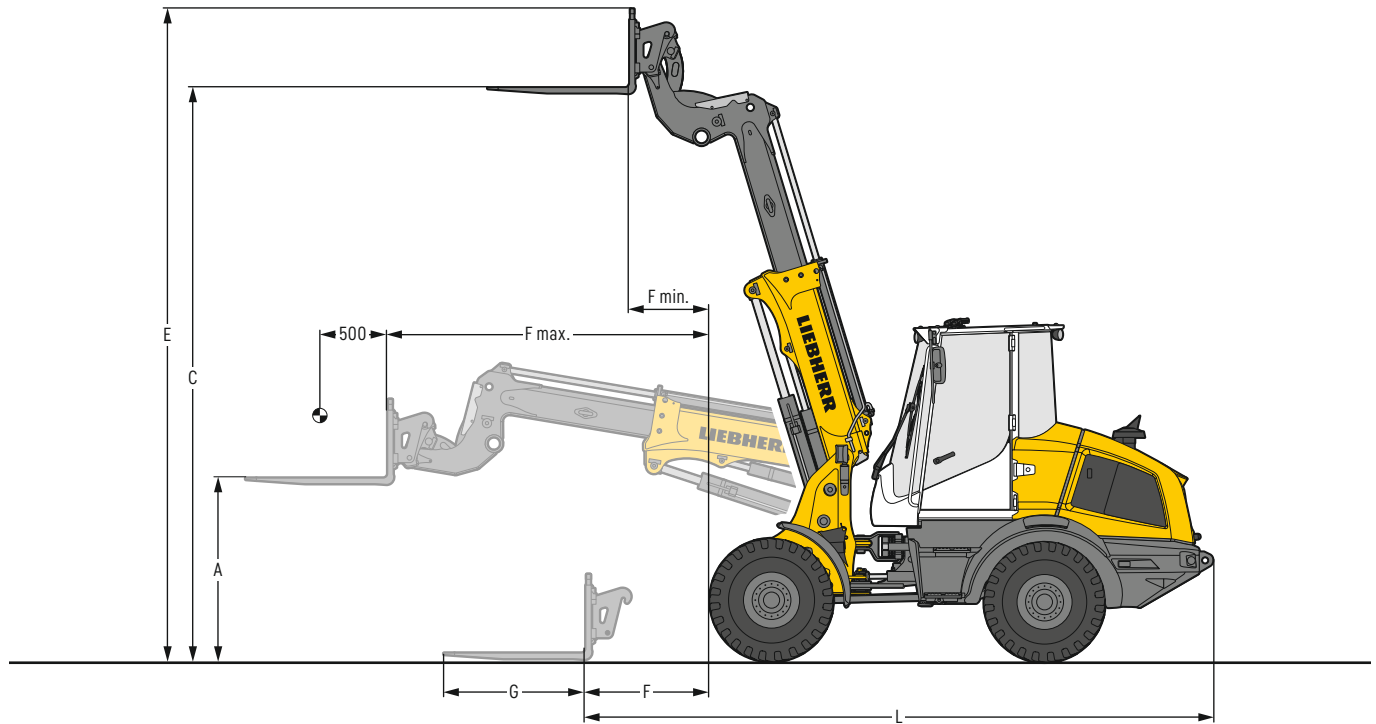

FEM IIB Fork carrier and fork

Geometry		TK-QH	
A	Lifting height at max. reach	mm	1,530
C	Max. lifting height	mm	4,800**
E	Max. operating height	mm	5,460
F	Reach at loading position	mm	1,030
F max.	Max. reach	mm	1,515 / 2,695
F min.	Reach at max. lifting height	mm	660
G	Fork length	mm	1,200
L	Length - basic machine	mm	5,270
	Tipping load, straight*	kg	3,400
	Tipping load, fully articulated*	kg	3,050
	Recommended payload for uneven ground = 60% of tipping load, articulated ¹⁾	kg	1,800
	Recommended payload for smooth surfaces = 80% of tipping load, articulated ¹⁾	kg	2,300
	Operating weight*	kg	6,800
	Tyre size		400/70R20 L3

* The figures shown include the above tyres, all lubricants, a full fuel tank, the ROPS/FOPS cab and the operator. Different tyres and optional equipment will change the operating weight and tipping load. (Tipping load, fully articulated according to ISO 14397-1).

** Depending on the selected forks.

¹⁾ According to EN 474-3

TTK-QH = Telescopic linkage incl. quick hitch

Bucket selection

L 509 Tele

Lift arm	Bucket	Material density (t/m ³)									
		0.4	0.6	0.8	1.0	1.2	1.4	1.6	1.8	2.0	
TK-QH	GPB 0.9 m ³							1.0	0.9		
	LMB 1.6 m ³			1.8	1.6						
		2.0 m ³		2.2	2.0						
	4in1 0.8 m ³							0.9	0.8		

Bucket filling factor

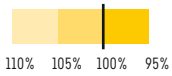

Lift arm

TK-QH	Telescopic linkage with quick hitch
-------	-------------------------------------

Bucket

GPB	General purpose bucket (Excavation bucket)
LMB	Light material bucket
4in1	4 in 1 bucket

Load curve

L 509 Tele FEM II Fork carrier and fork

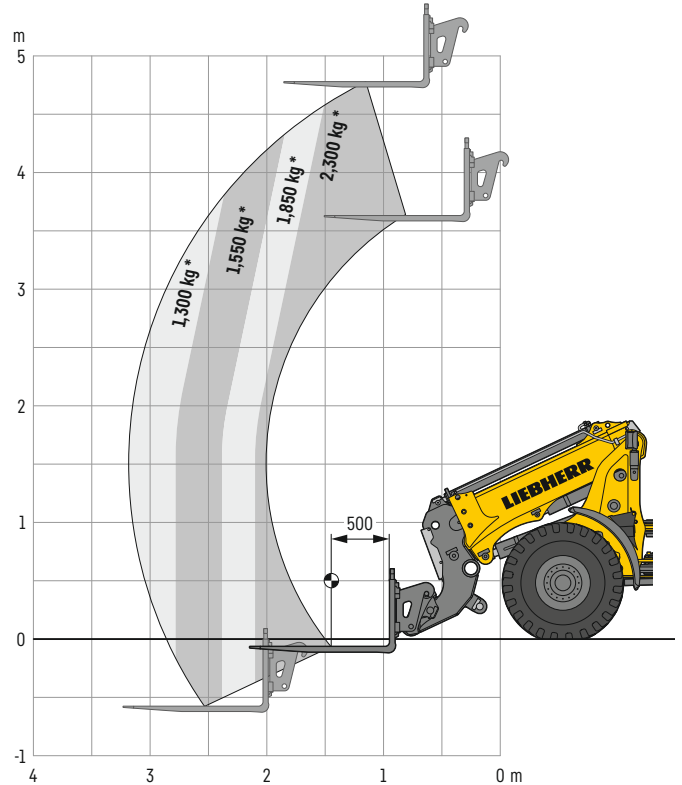

* Recommended payload for smooth surfaces = 80% of tipping load, articulated - according to 474-3

Bulk material densities and bucket filling factors

		t/m ³	%			t/m ³	%			t/m ³	%
Gravel	moist	1.9	105	Earth	dry	1.3	115	Glass waste	broken	1.4	100
	dry	1.6	105		wet excavated	1.6	110		solid	1.0	100
	crushed stone	1.5	100	Topsoil		1.1	110	Compost	dry	0.8	105
Sand	dry	1.5	105	Basalt		1.95	100	wet	1.0	110	
	wet	1.9	110	Granite		1.8	95	Wood chips / Saw dust		0.5	110
Gravel and Sand	dry	1.7	105	Sandstone		1.6	100	Paper	shredded / loose	0.6	110
	wet	2.0	100	Slate		1.75	100	recovered paper / cardboard	1.0	110	
Sand / Clay		1.6	110	Bauxite		1.4	100	Coal	heavy material density	1.2	110
Clay	natural	1.6	110	Limestone		1.6	100	light material density	0.9	110	
	dry	1.4	110	Gypsum	broken	1.8	100	Waste	domestic waste	0.5	100
Clay / Gravel	dry	1.4	110	Coke		0.5	110	bulky waste	1.0	100	
	wet	1.6	100	Slag	broken	1.8	100				

Tyres



Tyre types

	Size and tread code		Change of operating weight kg	Width over tyres mm	Change in vertical dimensions* mm	Use
L 509 Tele						
Goodyear	405/70R20 Powerload ¹⁾	L2	55	2,090	22	Sand, Gravel, Asphalt (all ground conditions)
Goodyear	405/70R18 Powerload	L2	0	2,080	- 11	Sand, Gravel, Asphalt (all ground conditions)
Goodyear	365/80R20 Powerload	L2	4	2,040	21	Sand, Gravel, Asphalt (all ground conditions)
Dunlop	15.5/55R18 SP PG7	L2	- 88	2,050	- 53	Sand, Gravel, Asphalt (all ground conditions)
Firestone	365/80R20 Duraforce UT	L3	24	2,050	28	Gravel, Asphalt, Industry (all ground conditions)
Firestone	400/70R20 Duraforce UT ¹⁾	L3	66	2,080	18	Gravel, Asphalt, Industry (all ground conditions)
Firestone	405/70R18 Duraforce UT	L3	36	2,090	- 2	Gravel, Asphalt, Industry (all ground conditions)
Firestone	400/70R20 R8000 UT ¹⁾	L2	43	2,080	18	Earthworks, Green area (all ground conditions)
Michelin	400/70R20 BIBLOAD ¹⁾	L3	40	2,080	13	Gravel, Asphalt, Industry (firm ground conditions)
Michelin	400/70R20 XMCL ¹⁾	L2	56	2,090	19	Earthworks, Green area (all ground conditions)
Mitas	405/70R18 EM-01	L2	0	2,090	0	Gravel, Asphalt, Industry (all ground conditions)
Mitas	365/80R20 EM-01	L2	16	2,050	27	Gravel, Asphalt, Industry (all ground conditions)
Mitas	405/70R20 EM-01 ¹⁾	L2	36	2,090	25	Gravel, Asphalt, Industry (all ground conditions)
Nokian	400/70R20 Hakkapeliitta TRI	L2	56.0	2,080	23	Winter tyres, Gravel, Asphalt, Industry (all ground conditions)
Trelleborg	400/70R20 TH400 ¹⁾	L2	50	2,080	13	Earthworks, Green area (all ground conditions)

* The stated values are theoretical and may deviate in practice.

¹⁾ Recommended tyre sizes from Liebherr-Werk Bischofshofen GmbH for optimum lateral stability.

Before operating the vehicle with tyre foam filling or tyre protection chains, please discuss this with the Liebherr-Werk Bischofshofen GmbH.

The Liebherr telescopic wheel loaders



Telescopic wheel loader

		L 509 Tele
Tipping load	kg	3,800
Bucket capacity	m ³	0.9
Operating weight	kg	7,000
Max. payload for fork carrier and fork	kg	2,300 ²⁾
Max. lifting height for fork carrier and fork	mm	4,800
Engine output	kW / HP	54 / 73

²⁾ Recommended payload for smooth surfaces = 80% of tipping load, articulated – according to 474-3

03.23

Equipment



Basic wheel loader

L 509

Connection for electrical equipment 7-pole	+
Automatic central lubrication system	+
Battery main switch (lockable)	●
Tool kit	●
Diesel particle filter	●
Ride control	+
Parking brake	●
Speed limitation 20 km/h or 30 km/h as a factory preset	+
Speed limit & fixed speed	+
Pre-heat system for cold starting	●
Rear license panel light	+
Combined inching-braking system	●
Fuel pre-filter	●
Cooling water pre-heating 220 V	+
Liebherr biodegradable hydraulic oil	+
Reversible fan drive	+
Guard for headlights	+
Windscreen guard	+
Side protective cover, front section	+
Special paint	+
Speeder version	●
Auxiliary heater (Additional heating with engine preheating)	+
Power socket rear (13-pole, 12 V)	+
Lockable doors and engine hood	●
Load lashing lugs	●
Air pre-cleaner	+
Tractive force adjustment	+
Towing hitch	●



Equipment

L 509

Working hydraulics lockout	●
Stroke limit damping	+
Fork carrier and pallet forks	+
High-Flow hydraulic	+
Hydraulic connections rear	+
Hydraulic quick hitch	●
Loading buckets incl. a range of cutting tools	+
Light material bucket	+
Comfort operation Tele	+
- Automatic bucket return programmable	
- Automatic lift arm position and lowering programmable	
- Visualisation of the equipment position	
Load holding valves telescopic cylinder	●
Headlights LED on the lift arm	+
Float position	●
Control lever lock	+
Telescopic linkage	●
1st electro-hydraulic, proportional additional function	●
1st and 2nd electro-hydraulic, proportional additional function	+

Equipment



Operator's cab

L 509

Storage compartment	•
Storage box	•
Exterior mirror, tiltable	•
Exterior mirror, tiltable and heatable	+
Fold-out window right 180°	•
Operating hour meter (integrated in display unit)	•
Roof glass panel	•
Electronical theft protection with code	+
Comfort Grammer operator's seat with longitudinal absorption, seat heating and 2-point seatbelt	+
Standard Grammer operator's seat with mechanical absorption and 2-point seatbelt	•
Particle filter F5	•
Fire extinguisher in cab 2 kg	+
Cup holder	•
Rear window heated electrically	•
Floor mat	•
Clothes hook	•
Air conditioning system	+
3 way continuously adjustable steering column (height-adjustable, tilting, folding)	+
Steering column folding	+
Steering column fixed	•
LiDAT (Liebherr data transfer system)	+
Liebherr control lever with mini-joystick for 1st hydraulic, proportional additional function moving with operator's seat (incl. travel direction)	•
Liebherr control lever with mini-joystick for 1st and 2nd hydraulic, proportional additional function moving with operator's seat (incl. travel direction)	+
Emergency exit	•
Premium display (Touchscreen), with height adjustment and tilting function	•
Preparation for radio installation	+
Radio Liebherr "Comfort" (DAB+ / USB / AUX / BLUETOOTH / handsfree set)	+
Radio Liebherr "Standard" (USB / AUX)	+



Operator's cab

L 509

Interior rear-view mirror	•
Amber beacon LED	+
Soundproof ROPS / FOPS cab	•
Wiper system front / rear	•
Roof glass panel windscreen wiper	+
Headlights rear, single design, halogen / LED	+
Headlights rear, double design, LED	+
Headlights front, single design, halogen	•
Headlights front, single design, LED	+
Headlights front, double design, LED	+
Sliding window left	+
Sunblind rear	+
Sunblind for roof screen	+
Sunblind front	•
Power socket 12V	•
First aid kit	+
Hot-water heater with defroster and recirculated air mode	•
Wide angle mirror	+



Safety

L 509

Country-specific versions	+
Back-up alarm acoustic / visual	+
Rear space monitoring with camera (integrated in display unit)	+
Overload warning system with load torque limit and load torque indicator via display	•

• = Standard, + = Option, - = not available

Here you can download our wheel loader brochures:



The Liebherr Group



Global and independent: more than 70 years of success

Liebherr was founded in 1949 when, with the development of the world's first mobile tower crane, Hans Liebherr laid the foundations for a family business now employing nearly 51,000 people and comprising over 140 companies across every continent.

The parent company is Liebherr-International AG in Bulle, Switzerland, whose associates are exclusively members of the Liebherr family.

Leaders and pioneers

Liebherr is a pioneer and its forward-looking approach has seen it make important contributions to technology history over a wide variety of industries. Employees throughout the world continue to share the courage of the founder, sharing a passion to produce innovative products and a determination to provide world-leading equipment and machinery.

Diversified portfolio

The company is one of the world's biggest construction equipment manufacturers and provides high-quality, user-oriented products and services to sectors including: earthmoving, material handling, deep foundations, mining, mobile and crawler cranes, tower cranes, concrete production and distribution, maritime cranes, aerospace and transportation, gear technology and automation, refrigeration and freezing, components and hotels.

Customised care

Liebherr solutions are characterised by precision, implementation and longevity. The company is committed to technological excellence and to providing customers with solutions that match their needs exactly. That customer focus does not end with delivery of a product but continues through a comprehensive range of back-up and support services.

www.liebherr.com

Liebherr-Werk Bischofshofen GmbH

Postfach 49 · 5500 Bischofshofen, Austria · Phone +43 50809 1-0 · Fax +43 50809 11385
info.lbh@liebherr.com · www.liebherr.com · www.facebook.com/LiebherrConstruction