

User Guide

base unit fridge

EN

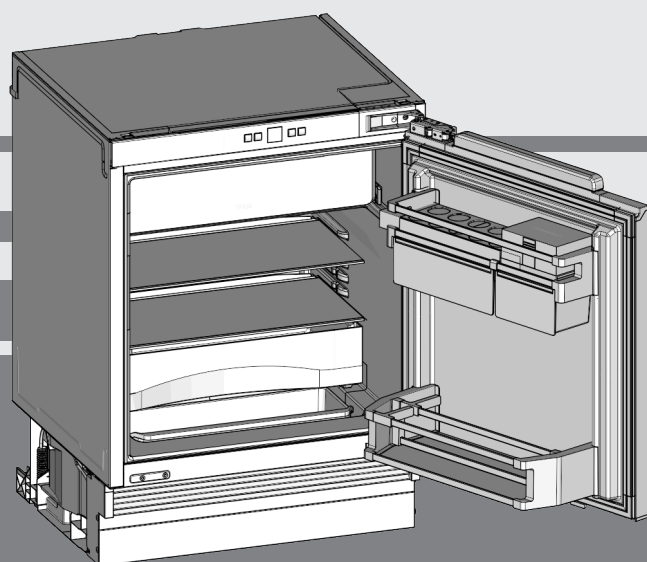

20241118 **7088065 - 01**

UIKP 1550/54

LIEBHERR

Appliance at a glance

Contents

1	Appliance at a glance	2
1.1	Overview of the appliance and its equipment.....	2
1.2	Appliance range of use.....	2
1.3	Conformity.....	3
1.4	SVHC substances according to REACH regulation.....	3
1.5	EPREL database.....	3
1.6	Spare parts.....	3
1.7	Saving energy.....	3
2	General safety instructions	3
3	Controls and displays	5
3.1	Operating and control elements.....	5
3.2	Temperature display.....	5
4	Putting into operation	5
4.1	Transporting the appliance.....	5
4.2	Disposing of packaging.....	5
4.3	Switching on the appliance.....	5
5	Control	5
5.1	Child proofing.....	5
5.2	Door alarm.....	5
5.3	SabbathMode.....	5
5.4	Refrigerator compartment.....	6
5.5	Freezer compartment*.....	8
6	Maintenance	10
6.1	Defrosting.....	10
6.2	Cleaning the appliance.....	10
6.3	Customer service.....	10
6.4	Energy efficiency class lighting.....	11
7	Malfunctions	11
8	Decommissioning	13
8.1	Switching off the appliance.....	13
8.2	Taking the appliance out of service.....	13
9	Disposal	13
9.1	Preparing appliance for disposal.....	13
9.2	Disposing of the appliance in an environmentally friendly manner.....	13

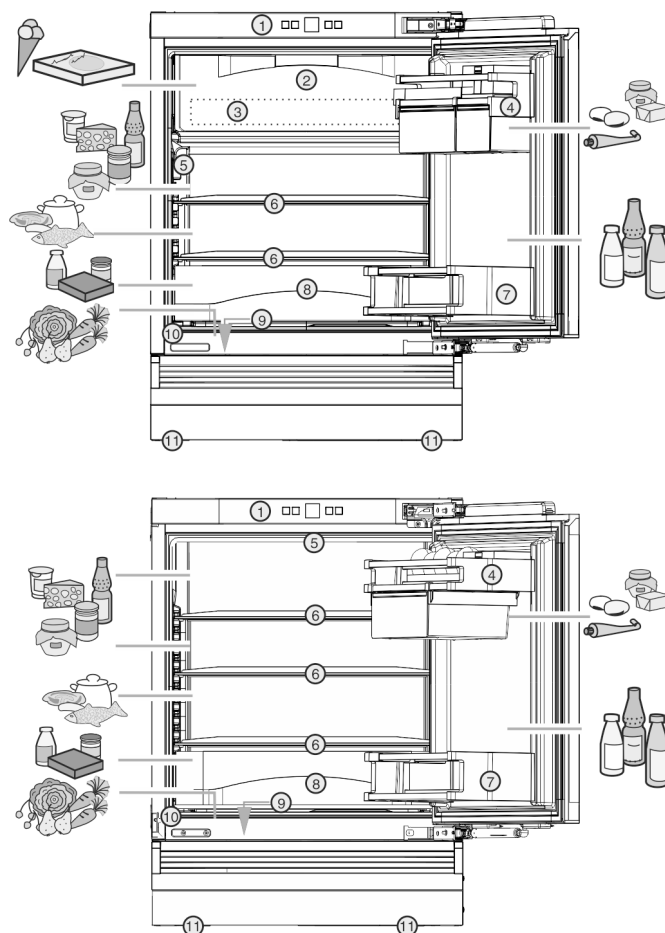

Fig. 1

- | | |
|----------------------------------|-------------------------------------|
| (1) Control panel | (7) Bottle shelf |
| (2) Freezer compartment* | (8) Drawer |
| (3) Bowl in freezer compartment* | (9) Vegetable bowl in the well |
| (4) Butter and cheese tray | (10) Model plate |
| (5) LED interior lighting | (11) Front and rear adjustable feet |
| (6) Removable shelf | |

The manufacturer works constantly on the further development of all the types and models. Therefore please understand that we have to reserve the right to make design, equipment and technical modifications.

To get to know all the benefits of your new appliance, please read the information contained in these instructions carefully.

The instructions apply to several models. Differences may occur. Text relating only to specific appliances is marked with an asterisk (*).

Instructions are marked with a ►, and results are marked with a ▷.

1 Appliance at a glance

1.1 Overview of the appliance and its equipment

Note

- Place food inside the appliance as shown in the diagram. This allows the appliance to save energy during operation.
- Shelves, drawers and baskets are arranged for optimum energy efficiency on delivery.

1.2 Appliance range of use

Intended use

The appliance is only suitable for cooling food products in a domestic or household-like environment. This includes, for example, use:

- in staff kitchens, bed and breakfast establishments,
- by guests in country houses, hotels, motels and other accommodation,
- for catering and similar services in the wholesale trade.

The appliance is not suitable for freezing food;*

The appliance is suitable for integrating under counters.

All other types of use are not permitted.

Foreseeable misuse

The following applications are expressly forbidden:

- Storing and refrigerating medicines, blood plasma, laboratory preparations or similar substances and products based on the Medical Device Directive 2007/47/EC
- Use in areas at risk of explosions

Misusing the appliance may lead to damage to the goods stored or they may spoil.

Climate classifications

Depending on the climate classification the appliance is designed to operate in restricted ambient temperatures. The climate classification applying to your appliance is printed on the rating plate.

Note

- ▶ Keep to the specified ambient temperatures in order to guarantee that the appliance works properly.

Climate classification	for ambient temperatures of
SN	10 °C to 32 °C
N	16 °C to 32 °C
ST	16 °C to 38 °C
T	16 °C to 43 °C
SN-ST	10 °C to 38 °C
SN-T	10 °C to 43 °C

1.3 Conformity

The refrigerant circuit has been tested for leaks. When installed, the appliance complies with the applicable safety regulations and with the corresponding directives.

For the EU market: The appliance complies with directive 2014/53/EU.

For the GB market: The appliance complies with Radio Equipment Regulations 2017 SI 2017 No. 1206.

The full text of the EU Declaration of Conformity is available on the following website: www.Liebherr.com

1.4 SVHC substances according to REACH regulation

You can check whether your appliance contains SVHC substances according to REACH regulation at the following link: home.liebherr.com/de/deu/de/liebherr-erleben/nachhaltigkeit/umwelt/scip/scip.html

1.5 EPREL database

Details about energy labelling and ecodesign requirements will be available on the European product database (EPREL) from 1st March 2021. You can access the product database at the following link: <https://eprel.ec.europa.eu/> You will be asked to enter the model ID. You can find the model ID on the nameplate.

1.6 Spare parts

The spare parts availability for functional parts and stockable parts of the equipment is 15 years.

1.7 Saving energy

- Pay attention to good ventilation. Do not cover ventilation holes or grids.
- Always keep the fan air slits clear.
- Do not install the appliance in direct sunlight or near radiators or similar sources of heat.
- If the appliance is installed directly next to an oven, the energy consumption may increase slightly. This is dependent on the service life and usage intensity of the oven.
- Energy consumption depends on the installation conditions, e.g. the ambient temperature (see 1.2 Appliance range of use). A warmer ambient temperature can increase the energy consumption.
- Open the appliance for as short a time as possible.
- The lower the temperature is set the higher the energy consumption.
- Sort your food: home.liebherr.com/food.
- Keep all food properly packed and covered. This prevents frost from forming.
- Only take food out for as long as necessary so that it doesn't warm up too much.
- Inserting warm food: allow to cool down to room temperature first.
- Thaw frozen food in the refrigerator.*
- If there is a thick layer of frost in the appliance: defrost the appliance.*

2 General safety instructions

Please keep these operating instructions in a safe place so you can refer back to them at any time.

If you pass the appliance on, please hand these operating instructions to the next user.

Read these operating instructions carefully before use to ensure safe and correct use of the appliance. Follow the instructions, safety instructions and warning messages included at all times. They are important for ensuring you can operate and install the appliance safely and without any problems.

Danger for the user:

- This device can be used by children and people with impaired physical, sensory or mental abilities or with a lack of experience and knowledge provided that they are supervised or have received instruction in the safe use of this device, and about the resulting hazards.

Children must not play with this appliance. Cleaning and user maintenance work must not be carried out by children without adult supervision. Children aged between 3 and 8 are allowed to load and unload the appliance. Children below the age of 3 must be

General safety instructions

kept away from the appliance unless they are under continuous adult supervision.

- The socket must be easily accessible so that the appliance can be disconnected quickly from the electricity in an emergency. It must not be located in the area behind the appliance.
- When disconnecting the appliance from the supply, always take hold of the plug. Do not pull the cable.
- In the event of a fault pull out the mains plug or deactivate the fuse.
- Do not damage the mains power cable. Do not operate the appliance with a defective mains power cable.
- Repairs, interventions on the appliance and the replacement of mains connection line may only be carried out by AfterSales Service or other suitably trained specialist personnel.
- Only install, connect and dispose of the appliance according to the instructions.
- Only use the appliance when is installed.

Fire hazard:

- The coolant used (information on the model plate) is ecofriendly but also flammable. Any leaking coolant may ignite.
 - Do not damage the refrigerant circuit pipes.
 - Do not handle ignition sources inside the appliance.
 - Do not use electrical appliances inside the appliance (e.g. steam cleaners, heaters, ice cream makers, etc.).
 - If the refrigerant leaks: remove any naked flames or ignition sources from the vicinity of the leakage point. Properly air the room. Inform customer services.
- Do not store explosives or sprays using combustible propellants such as butane, propane, pentane, etc. in the appliance. To identify these spray cans, look for the list of contents printed on the can, or a flame symbol. Gases possibly escaping may ignite due to electrical components.
- Keep burning candles, lamps and other items with naked flames away from the appliance so that they do not set the appliance on fire.
- Please be sure to store alcoholic drinks or other packaging containing alcohol in tightly closed containers. Any alcohol that leaks out may be ignited by electrical components.

Danger of tipping and falling:

- Do not misuse the plinth, drawers, doors etc. as a step or for support. This applies particularly to children.

Danger of food poisoning:

- Do not consume food which has been stored too long.

Danger of frostbite, numbness and pain:

- Avoid prolonged skin contact with cold surfaces or refrigerated/frozen goods or take protective measures, e.g wear gloves.

Danger of injury and damage:

- Hot steam can lead to injury. Do not use electrical heating or steam cleaning equipment, open flames or defrosting sprays to defrost.
- Do not use sharp implements to remove the ice.

Risk of crushing:

- Do not hold the hinge when opening and closing the door. Fingers may get caught.

Symbols on the appliance:



This symbol may be located on the compressor. It relates to the oil in the compressor and makes reference to the risk that: Swallowing or inhaling can be fatal. This advice is only relevant to recycling. There is no danger in normal operation.



This symbol is located on the compressor and indicates the danger of flammable materials. Do not remove the sticker.



This or a similar sticker may be located on the rear of the appliance. This sticker indicates that there are vacuum insulation panels (VIP) or perlite panels in the door and/or housing. This advice is only relevant to recycling. Do not remove the sticker.

Please note the warning messages and other specific advice in the other chapters:

	DANGER	indicates an immediately hazardous situation which will lead to death or serious injuries if it is not avoided.
	WARNING	indicates a hazardous situation which may lead to death or serious injuries if it is not avoided.
	CAUTION	indicates a hazardous situation which may lead to minor or moderate injuries if it is not avoided.
	NOTICE	indicates a hazardous situation which may lead to damage to property if it is not avoided.

Note indicates useful instructions and tips.

3 Controls and displays

3.1 Operating and control elements

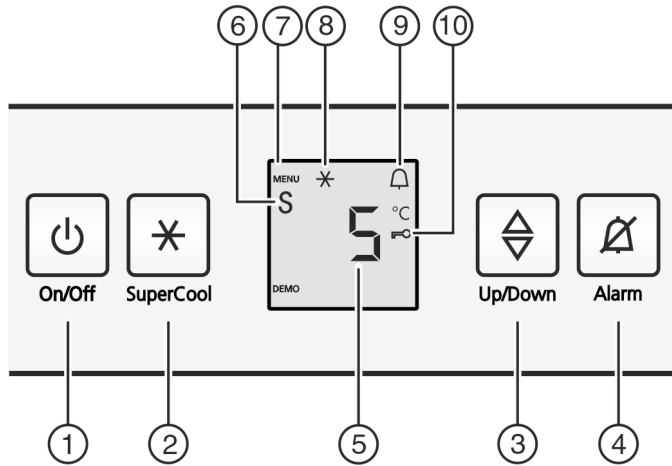

Fig. 2

- | | |
|-------------------------|-------------------------|
| (1) On/Off button | (6) Sabbath Mode symbol |
| (2) SuperCool button | (7) Menu symbol |
| (3) Settings button | (8) SuperCool symbol |
| (4) Alarm button | (9) Alarm symbol |
| (5) Temperature display | (10) Child lock symbol |

3.2 Temperature display

During normal operation, the display shows:

- the average cooling temperature

The temperature display flashes if/when:

- You change the temperature setting

The following displays indicate a fault. Possible causes and solutions: (see 7 Malfunctions).

- **F0** to **F9**

4 Putting into operation

4.1 Transporting the appliance

- ▶ Transport the appliance only in suitable packaging.
- ▶ Transport the appliance upright.
- ▶ Do not transport the appliance on your own.

4.2 Disposing of packaging



WARNING

Danger of suffocation due to packing material and plastic film!

- ▶ Do not allow children to play with packing material.

The packaging is made of recyclable materials:

- corrugated board/cardboard
- expanded polystyrene parts
- polythene bags and sheets
- polypropylene straps
- nailed wooden frame with polyethylene panel*

- ▶ Take the packaging material to an official collecting point.

4.3 Switching on the appliance

- ▶ Open the door.
- ▶ Press the On/Off button Fig. 2 (1).
- ▷ The temperature display lights up. The appliance is switched on.
- ▷ If "DEMO" is displayed, demo mode is activated. Please contact the after sales service.



5 Control

5.1 Child proofing

The child-proofing function enables you to make sure that the appliance is not inadvertently switched off by playing children.



5.1.1 Setting the child lock function

- ▶ Activate setting mode: Press the SuperCool button Fig. 2 (2) for around 5 seconds.
- ▷ The display indicates **5**.
- ▷ The menu symbol Fig. 2 (7) shines.
- ▶ Use the Settings button Fig. 2 (3) to select **c**.
- ▶ Briefly press the SuperCool button Fig. 2 (2) to confirm. When **cl** is indicated in the display:
- ▶ to activate the child lock, briefly press the SuperCool button Fig. 2 (2).



- ▷ The child lock symbol Fig. 2 (10) shines. **c** flashes in the display.
- When **cl** is indicated in the display:
- ▶ to deactivate the child lock, briefly press the SuperCool button Fig. 2 (2).
- ▷ The child lock symbol Fig. 2 (10) goes out. **c** flashes in the display.
- ▶ To deactivate the set-up mode: press On/Off button Fig. 2 (1).
- or-
- ▶ Wait for 5 minutes.
- ▷ The temperature is indicated again in the temperature display.

5.2 Door alarm

For the fridge compartment

An audible warning sounds if the door is open for longer than 60 seconds.

The audible warning stops automatically when the door is closed.



5.2.1 Muting the door alarm

The audible alarm can be muted when the door is open. The sound switch-off function is active as long as the door is left open.

- ▶ Press alarm button Fig. 2 (4).
- ▷ The door alarm is silenced.

5.3 SabbathMode

This function meets the religious requirements on the Sabbath or Jewish festivals. Turn on SabbathMode to

Control

switch off certain controls. After setting up SabbathMode, you no longer need to worry about indicator lights, figures, symbols, displays, alarms or fans. The thawing cycle only works for the specified time without taking account of fridge use. After a power cut the appliance automatically returns to SabbathMode.

There is a list of Star-K certified appliances at www.star-k.org/appliances.



WARNING

Danger of food poisoning.

If there is a power cut while the appliance is in SabbathMode, this message is not saved. Once power is restored, the appliance continues in SabbathMode. When this mode is over no message about the power cut is displayed on the temperature display.

If there was a power cut during SabbathMode:

- ▶ Check the food for quality. Do not eat the food if it has thawed.

- All functions are locked until SabbathMode is switched off.
- If functions such as SuperFrost, SuperCool, Ventilation, etc. are activated when SabbathMode is on, they remain active.
- No audible signals are emitted and the temperature display does not indicate any warnings or settings (such as a temperature alarm or door alarm).
- The internal light is off.

5.3.1 Setting Sabbath Mode

- ▶ Activate setting mode: Press the SuperCool button *Fig. 2 (2)* for around 5 seconds.
- ▷ **S** flashes in the display.
- ▷ The Menu symbol *Fig. 2 (7)* lights up.
- ▶ To call up the Sabbath Mode function: Briefly press the SuperCool button *Fig. 2 (2)*.
- ▷ **S** flashes in the display.

If you see **SI** in the display:

- ▶ To switch on Sabbath Mode, briefly press the SuperCool button *Fig. 2 (2)*.

If you see **SO** in the display:

- ▶ To switch off Sabbath Mode, briefly press the SuperCool button *Fig. 2 (2)*.
- ▶ Deactivate setting mode: Press the On/Off button *Fig. 2 (1)*.

-or-

- ▶ Wait 5 min.

- ▷ The temperature display shows the Sabbath Mode symbol *Fig. 2 (6)* as long as Sabbath Mode is on.
- ▷ Sabbath Mode switches off automatically after 120 hours if it has not already been switched off manually.

5.4 Refrigerator compartment

The natural circulation of air in the refrigerator compartment results in zones differing in temperature. It is coldest directly above the vegetable drawers and at the rear wall. It is warmest at the top front of the compartment and in the door.

5.4.1 Refrigerating food

The coldest areas are directly above the vegetable compartments and along the back wall. The warmest area is at the top front and in the door.*

- ▶ Store perishable foods such as ready-to-eat meals, meat and sausages in the coldest area. Place butter and preserves in the top area and in the door. (see 1 Appliance at a glance)
- ▶ Use reuseable plastic, metal, aluminium, glass containers and foil wrap to store food.
- ▶ Always store raw meat and fish in clean, sealed containers on the bottom shelf of the refrigerator, to prevent them coming into contact with or dripping onto other foods.
- ▶ Foods that easily absorb or give off smell or taste, as well as liquids, should be stored in sealed containers or covered.
- ▶ Do not pack foods too closely together, as the air needs to circulate.

5.4.2 Setting the temperature

The temperature depends on the following factors:

- the frequency of opening the door
- how long the door is open for
- the room temperature of the installation location
- the type, temperature and quantity of the food

An average temperature of approx. -18 °C is then established in the freezer compartment.*

The temperature is changed sequentially. Once the 2 °C setting is reached, the sequence starts again at 9 °C.

- ▶ Call up temperature function: press the setting button *Fig. 2 (3)*.
- ▷ The previously-set value will flash in the temperature display.
- ▶ Change the temperature in 1 °C steps: Press the setting button *Fig. 2 (3)* until the required temperature is indicated in the temperature display.
- ▶ Change temperature continually: hold down setting button.
- ▷ During adjustment the value flashes on the display.
- ▷ The new setting is adopted approx. 5 seconds after the last time the button was pressed and the set temperature is again displayed. The temperature in the interior gradually adjusts to the new value.



5.4.3 SuperCool

SuperCool is for maximum cooling. This option is for very low temperatures:

- In the fridge compartment
- In the freezer compartment*



Use SuperCool to quickly cool large amounts of food.

To freeze food, activate SuperCool when you place the goods in the appliance.*

When SuperCool is activated, the fan* may run. The appliance operates with maximum cooling performance, which means that the noise of the refrigeration unit may be temporarily louder.

The SuperCool function uses slightly more energy.

Switching onSuperCool

- ▶ Briefly press SuperCool button *Fig. 2 (2)*.
- ▷ The SuperCool *Fig. 2 (8)* symbol lights up in the display.
- ▷ The cooling temperature drops to the lowest setting.
- ▷ SuperCool is on.
- ▷ SuperCool turns off automatically. The appliance continues in energy-saving Normal mode.

To prematurely deactivate SuperCool

- ▶ Briefly press SuperCool button *Fig. 2 (2)*.
- ▷ The SuperCool symbol *Fig. 2 (8)* goes out in the display.

▷ SuperCool is deactivated.

5.4.4 Shelves

Moving or removing shelves

The shelves are prevented from being pulled out accidentally by pull out stops.

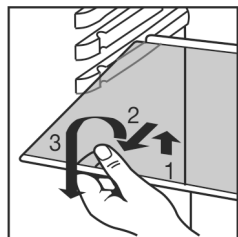
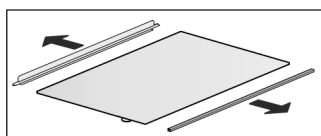

Fig. 3

- ▶ Lift the shelf and pull it out towards the front.
- ▶ Insert shelf with the raised edge pointing upwards at the back.
- ▷ The food does not freeze onto the rear wall.

Dismantling shelves

- ▶ The shelves can be dismantled for cleaning.



5.4.5 Door racks

Removing the storage rack

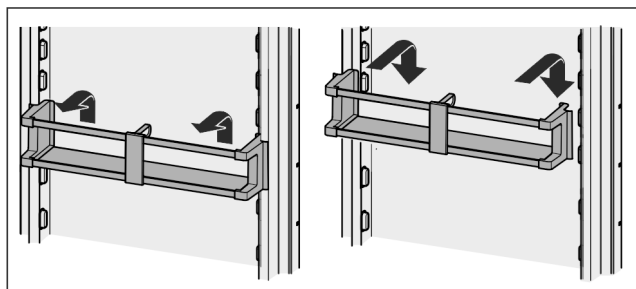

Fig. 4

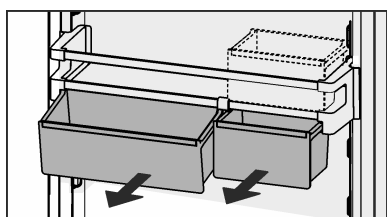

Fig. 5 *

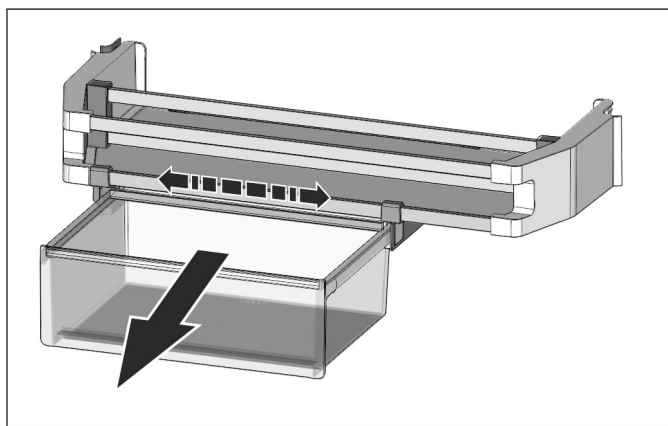
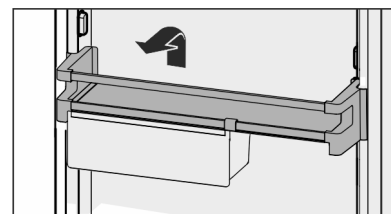
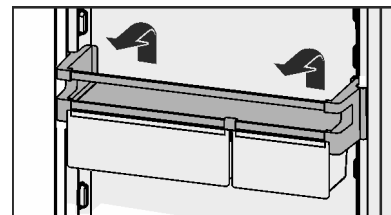

Fig. 6 *

You can use just one or both boxes. To store oversized bottles, just suspend one box over the bottle rack. Store the other box in the holder.*



- ▶ Re-positioning the boxes: Lift them for removal and re-position them as required.

Dismantling door racks

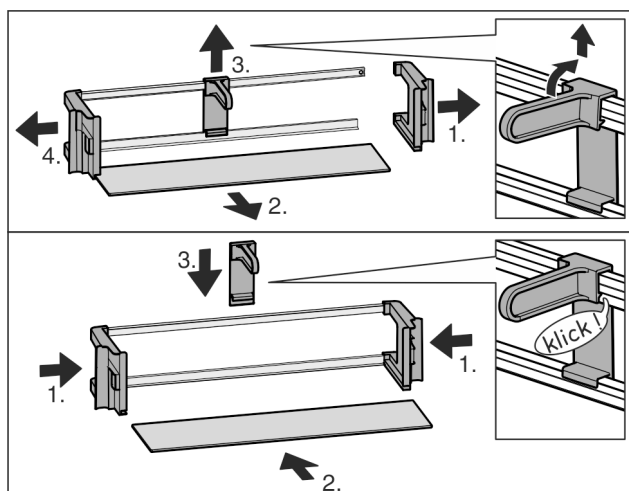

Fig. 7

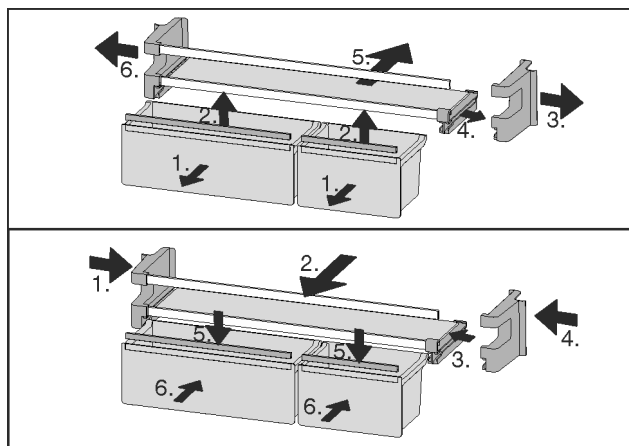

Fig. 8 *

Control

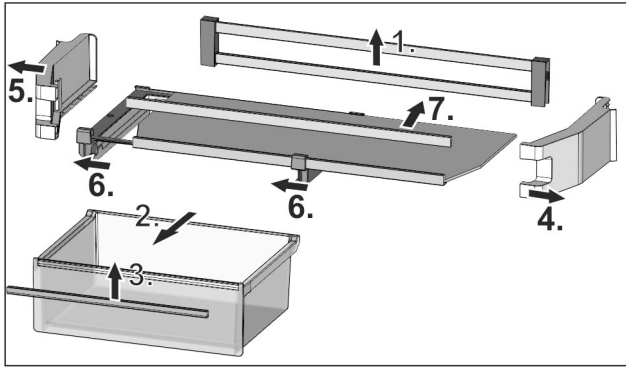
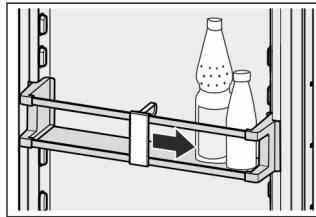

Fig. 9*

- ▶ The door racks can be dismantled for cleaning.

5.4.6 Using the bottle holder

- ▶ To avoid the bottles tipping over, push the bottle holder along.



5.4.7 Butter dish

Opening/closing the butter dish

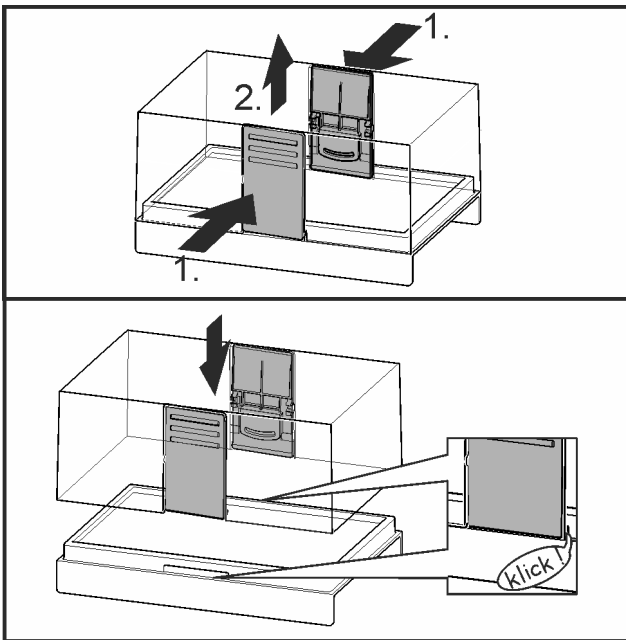

Fig. 10

Dismantling the butter dish

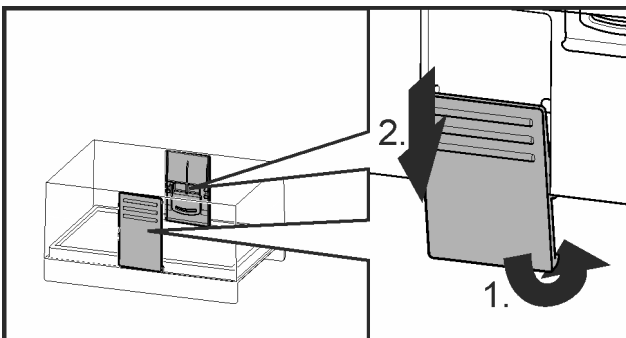
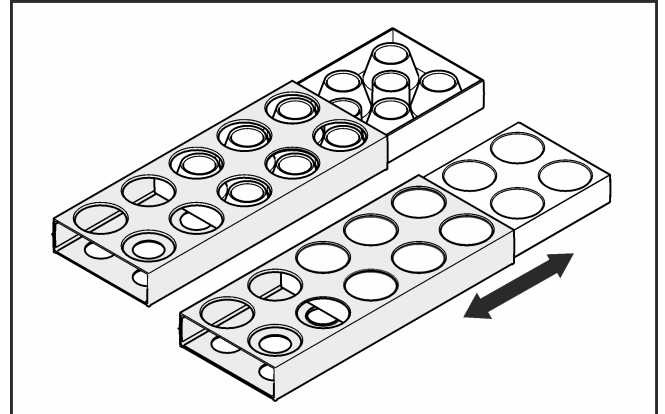

Fig. 11

- ▶ You can take the butter dish apart for cleaning.

5.4.8 Egg tray

You can take out and rotate the egg tray. You can use the two parts of the egg tray to mark different use-by dates, for example.



- ▶ Use the top part to store e.g. chicken eggs.
- ▶ Use the bottom part to store quails' eggs.

5.4.9 Drawer

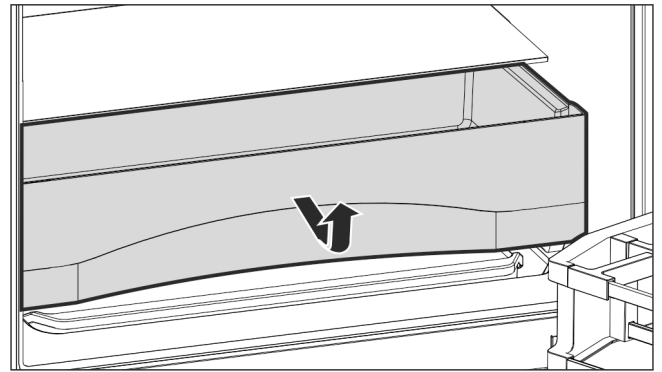

Fig. 12

5.5 Freezer compartment*

You can store frozen food for several months, make ice cubes and freeze fresh food in the freezer compartment at a temperature of -18 °C and lower.

The air temperature in the compartment, measured by thermometer or other instruments, may fluctuate.

5.5.1 Opening the freezer compartment

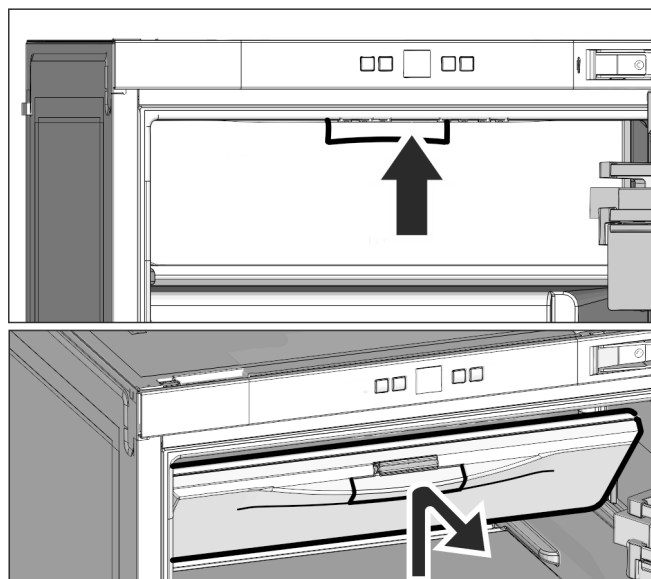

Fig. 13

To open the freezer compartment, push the handle up and pull the freezer door towards you.

When closing the freezer, push on the handle to make sure the lock clicks into place.

5.5.2 Freezing food

The rating plate indicates the maximum quantity of fresh food you can freeze within 24 hours (see 1 Appliance at a glance) under "Freezing capacity ... kg/24h".



CAUTION

Risk of injury due to broken glass!

Bottles and cans containing drinks may burst when being frozen. This applies particularly to sparkling drinks.

▶ Do not freeze bottles and cans containing drinks!

▶ Switch on SuperCool 4 hours before freezing and set the temperature to 4 °C or less.

▶ Once the food is frozen, you can reset the temperature and switch off SuperCool.

So that the food is rapidly frozen through to the core, do not exceed the following quantities per pack

- Fruit, vegetables up to 1 kg

- Meat up to 2.5 kg

▶ Pack the food in portions in freezer bags, reusable plastic, metal or aluminium containers

5.5.3 Storage times

Guide times for storing various types of food in the freezer compartment:

Ice cream	2 to 6 months
Sausage, ham	2 to 6 months
Bread, bakery products	2 to 6 months
Game, pork	6 to 10 months
Fish, fatty	2 to 6 months
Fish, lean	6 to 12 months
Cheese	2 to 6 months
Poultry, beef	6 to 12 months

Guide times for storing various types of food in the freezer compartment:

Vegetables, fruit	6 to 12 months
-------------------	----------------

Storage times given are guide times.

5.5.4 Thawing food

- in the refrigerator compartment
- in a microwave oven
- in a conventional or fan oven
- at room temperature

▶ Remove only as much food as is required. Use thawed food as quickly as possible.

▶ Food once thawed should be re-frozen only in exceptional cases.

5.5.5 Bowl in freezer compartment*

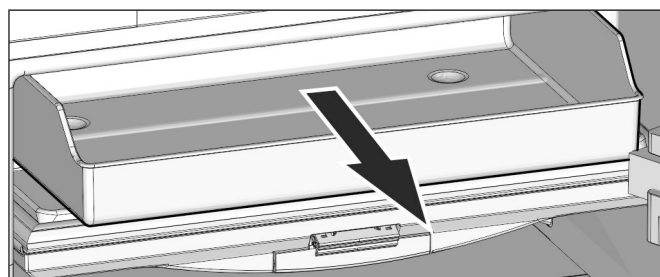

Fig. 14

You can store the packaged frozen goods in the bowl. To easily remove your frozen items, pull the bowl towards you and take it out.

5.5.6 Ice cube tray

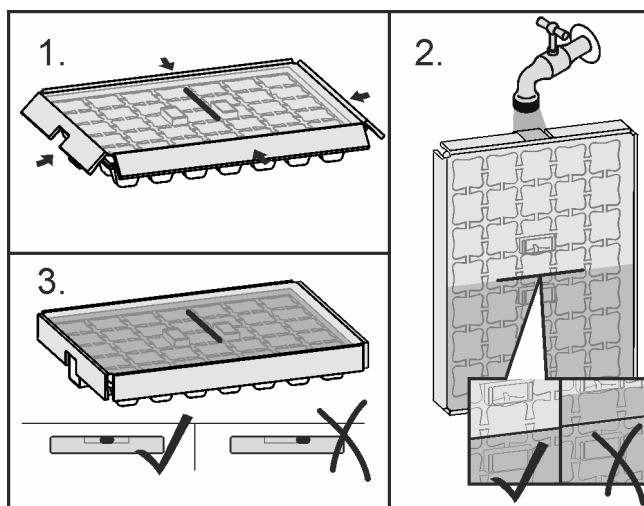

Fig. 15

When the water is frozen:

▶ Hold ice cube tray under hot water for a short time.

▶ Remove the lid.

▶ Gently turn the ends of the ice cube tray in opposite directions and release the cubes.

Dismantling the ice cube tray

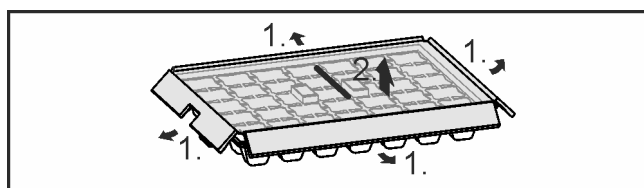

Fig. 16

Maintenance

- ▶ You can take the ice cube tray apart for cleaning.

6 Maintenance

6.1 Defrosting

6.1.1 Defrosting refrigerator compartment

The fridge compartment defrosts automatically. The defrosted water will evaporate. Water drops or a thin layer of frost or ice can form on the back wall; this is a completely normal part of the machine's function.

- ▶ Clean the drain hole at regular intervals to allow the defrost water to drain (see 6.2 Cleaning the appliance).

6.1.2 Defrosting freezer compartment*

A layer of frost and ice forms in the freezer compartment after the appliance has been in use for a lengthy period of time. This is quite normal. The layer of frost and ice forms more quickly if the door is opened frequently or if the food is warm when placed inside. However, a thick layer of ice will increase the appliance's energy consumption. You should therefore defrost the appliance regularly.



WARNING

Improper defrosting of the appliance!
Injuries and damage.

- ▶ Do not use mechanical equipment or other methods to speed up the defrosting process other than those recommended by the manufacturer.
 - ▶ Do not use electrical heating or steam-cleaning appliances, naked flames or defroster sprays to defrost.
 - ▶ Do not use sharp objects to remove ice.
-
- ▶ Switch off the appliance.
 - ▷ The temperature display goes out.
 - ▷ If the temperature display does not go out, the child-proofing function (see 5.1 Child proofing) is active.
 - ▶ Pull out the plug.
 - ▶ Wrap the frozen food in newspaper or blankets and store in a cool place.
 - ▶ Leave the compartment and appliance door open during defrosting.
 - ▶ Remove detached pieces of ice.
 - ▶ Pay attention that the defrost water does not run into the kitchen unit.
 - ▶ If necessary, pick up defrost water several times, using a sponge or cloth.
 - ▶ Clean the compartment (see 6.2 Cleaning the appliance).

6.2 Cleaning the appliance

Clean the appliance regularly.



WARNING

Risk of injury and damage as a result of hot steam!
Hot steam can lead to burns and can damage the surfaces.

- ▶ Do not use any steam cleaners!

NOTICE

Incorrect cleaning damages the appliance!

- ▶ Do not use cleaning agents in concentrated form.
- ▶ Do not use any scouring or abrasive sponges or steel wool.
- ▶ Do not use any sharp or abrasive cleaning agents, nor any that contain sand, chloride or acid.
- ▶ Do not use chemical solvents.
- ▶ Do not damage or remove the type plate on the inside of the appliance. It is important for the customer service.
- ▶ Do not pull off, bend or damage cables or other components.
- ▶ Do not allow any cleaning water to enter the drain channel, ventilation grille or electrical parts.
- ▶ Please use soft cleaning cloths and a universal pH-neutral cleaning agent.
- ▶ Please use cleaning and care products suitable for contact with foodstuffs in the appliance interior.

- ▶ **Empty appliance.**
- ▶ **Pull out the power plug.**



- ▶ Clean the **vent grille** regularly.
- ▷ Dust deposits increase energy consumption.
- ▶ Clean **plastic outer and inner surfaces** with lukewarm water and a little washing-up liquid.
- ▶ Clean **drain hole**: Remove deposits with a narrow instrument, e.g. a cotton bud.

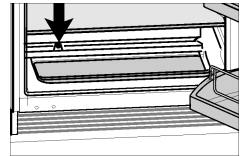

- ▶ Most of the **parts** can be dismantled for cleaning: see the relevant chapter.
- ▶ **Clean drawers** by hand with lukewarm water and a little washing up liquid.
- ▶ All the **other fittings** can be put in the dishwasher.

After cleaning:

- ▶ Wipe dry the appliance and items of equipment.
- ▶ Connect the appliance and switch it on again.
When the temperature is sufficiently cold:
- ▶ Put the food back inside.

6.3 Customer service

First check whether you can rectify the fault yourself (see 7 Malfunctions). If you cannot rectify the problem, contact Customer Services. You can find the address in the enclosed Customer Service Directory.



WARNING

Unprofessional repair!
Injuries.

- ▶ Have any repairs and action - not expressly specified - on the appliance and mains cable carried out by service personnel only. (see 6 Maintenance)
- ▶ A damaged mains cable may only be replaced by the manufacturer, the manufacturer's Customer Service or a similarly qualified person.
- ▶ In the case of appliances with an IEC connector, the change may be made by the customer.

- ▶ Read the appliance designation Fig. 17 (1), service No. Fig. 17 (2) and serial No. Fig. 17 (3) off the model plate located inside the appliance on the left-hand side.

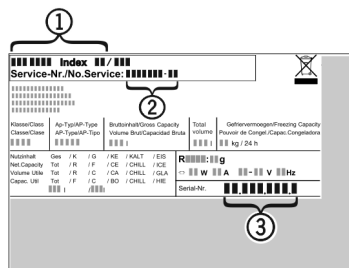

Fig. 17

- ▶ Notify the customer service, specifying the fault, appliance designation Fig. 17 (1), service No. Fig. 17 (2) and serial No. Fig. 17 (3).
- ▷ This will help us to provide you with a faster and more accurate service.
- ▶ Keep the appliance closed until the customer service arrives.
- ▷ The food will stay cool longer.
- ▶ Pull out the mains plug (not by pulling the connecting cable) or switch off the fuse.

6.4 Energy efficiency class lighting

Lighting	
Energy efficiency class ¹	Light source
This product contains an energy efficiency class G light source	LED



¹ The appliance may contain light sources with different energy efficiency classes. The lowest energy efficiency class is indicated.

7 Malfunctions

Your appliance is designed and manufactured for a long life span and reliable operation. If a malfunction nonetheless occurs during operation, check whether it is due to a handling error. In this case you will have to be charged for the costs incurred, even during the warranty period. You may be able to rectify the following faults yourself:

Defect	Cause	Remedy
Appliance does not work.	→ The appliance is not switched on.	▶ Switching on the appliance.
	→ The power plug is not properly inserted in the wall socket.	▶ Check power plug.
	→ The fuse of the wall socket is not in order.	▶ Check fuse.
The compressor runs for a long time.	→ The compressor switches to a low speed when little cold is needed. Although the running time is increased as a result, energy is saved.	▶ This is normal in energy-saving models.
	→ SuperCool is activated.	▶ The compressor runs for longer in order to rapidly cool the food. This is normal.
A LED on the bottom rear of the appliance (at the compressor) flashes repeatedly every 5 seconds*.	→ There is a fault.	▶ Please contact the after-sales service (see 6 Maintenance).
Excessive noise.	→ Due to the various speed steps, speed-regulated* compressors can generate different running noises.	▶ The sound is normal.
A bubbling and gurgling noise.	→ This noise comes from the refrigerant flowing in the refrigeration circuit.	▶ The sound is normal.
A quiet clicking noise.	→ The noise is produced whenever the refrigeration unit (motor) automatically switches on or off.	▶ The sound is normal.
A hum. It is briefly a little louder when the refrigeration unit (the motor) switches on.	→ The refrigeration increases automatically when the SuperCool function is activated, fresh food has just been placed in the appliance or the door has been left open for a while.	▶ The sound is normal.
	→ The ambient temperature is too high.	▶ Solution: (see 1.2 Appliance range of use)
A low hum.	→ The sound is produced by air flow noise of the fan.	▶ The sound is normal.

Malfunctions

Defect	Cause	Remedy
Vibration noises	→ The appliance is not standing firmly on the floor. As a result objects and adjacent units start to vibrate when the refrigerator is running.	<ul style="list-style-type: none"> ▶ Check the installation and realign the appliance. ▶ Keep bottles and jars apart.
Flow sound at the soft stop mechanism.	→ The noise is produced when the door is opened and closed.	▶ The sound is normal.
The temperature display indicates: F0 to F9	→ There is a fault.	▶ Please contact the after-sales service (see 6 Maintenance) .
DEMO shines in the temperature display.	→ The demo mode is activated.	▶ Please contact the after-sales service (see 6 Maintenance) .
The outer surfaces of the appliance are warm*.	→ The heat of the refrigeration circuit is used to prevent condensate from forming.	▶ This is normal.
The temperature is not cold enough.	→ The door of the appliance is not properly closed.	▶ Close the door of the appliance.
	→ Insufficient ventilation.	▶ Keep ventilation grille clear, and clean it.
	→ The ambient temperature is too high.	▶ Solution: (see 1.2 Appliance range of use) .
	→ The appliance was opened too frequently or for too long.	▶ Wait to see whether the appliance reaches the required temperature by itself. If not, please contact the after sales service (see 6 Maintenance) .
	→ The temperature is incorrectly set.	▶ Set the temperature to a colder setting and check after 24 hours.
	→ The appliance is too close to a source of heat (stove, heater etc).	▶ Change the position of the appliance or the source of heat.
	→ The appliance was not inserted properly into the recess.	▶ Check whether the appliance was inserted correctly and the door closes properly.
The internal light does not come on.	→ The appliance is not switched on.	▶ Switch the appliance on.
	→ The door was open for longer than 15 minutes.	▶ The internal light switches itself off automatically after about 15 minutes if the door is open.
	→ The LED illumination is faulty or the cover is damaged:	<hr/> <p> WARNING Risk of injury due to electric shock! There are live electrical parts under the cover. ▶ Only ever have the inside LED light replaced or repaired by customer service or trained personnel.</p> <hr/> <p> WARNING Risk of injury from LED bulb! The light intensity of the LED light corresponds to hazard group RG 2. If the cover is defective: ▶ Do not look directly into the light from close range. It cause injury to the eyes.</p> <hr/>
The door seal is defective or needs to be replaced for another reason.	→ The door seal can be replaced. It can be replaced without the need for special tools.	▶ Contact Customer Service (see 6 Maintenance) :

Defect	Cause	Remedy
The unit has iced up or condensation has formed.	→ The door seal may have also slipped out of its groove.	▶ Check to ensure that the door seal is seated properly in the groove.

8 Decommissioning

8.1 Switching off the appliance

- ▶ Press the On/Off button *Fig. 2 (1)* until the display goes dark. Release button.
- ▷ If the appliance cannot be switched off, the child lock function is active (see 5.1 Child proofing) .

8.2 Taking the appliance out of service

- ▶ Empty the appliance.
- ▶ Switch off the appliance (see 8 Decommissioning) .
- ▶ Remove mains connector.
- ▶ Clean the appliance (see 6.2 Cleaning the appliance) .



- ▶ Leave the door open to prevent odour.

9 Disposal

9.1 Preparing appliance for disposal



Liebherr uses batteries in some of its appliances. In the EU, for environmental reasons, legislation obliges the end user to remove these batteries before disposing of old appliances. If your appliance contains batteries, a corresponding notice is attached.

Lamps If you can remove the lamps yourself without destroying them, also remove these before disposal.

- ▶ Take the appliance out of operation. (see 8.2 Taking the appliance out of service)
- ▶ Appliances with batteries: remove the batteries. For description, see **Maintenance** chapter.
- ▶ If possible: remove lamps without destroying them.

9.2 Disposing of the appliance in an environmentally friendly manner



The appliance still contains valuable materials and must be disposed of separately from unsorted municipal waste.



Dispose of batteries separately from the old appliance. To do this, you can return the batteries free of charge to retailers as well as recycling centres and collection centres for recyclable materials.

Lamps Dispose of removed lamps via the respective collection systems.

For Germany:

You can dispose of the appliance free of charge via the class 1 collection containers at the local recycling and recyclable material collection centres. When purchasing a new fridge/freezer, if the sales area > 400 m², retailers will also take back the old appliance free of charge.



WARNING

Leaking coolant and oil!

Fire. The coolant contained in the appliance is eco-friendly, but also flammable. The oil contained in the appliance is flammable. Escaping coolant and oil can ignite if the concentration is high enough and in contact with an external heat source.

- ▶ Do not damage the pipelines of the coolant circuit and the compressor.

- ▶ Observe the notes on transporting the appliance. (see 4.1 Transporting the appliance)
- ▶ Transport the appliance without damaging it.
- ▶ Dispose of batteries, lamps and the appliance according to the above specifications.



Liebherr-Hausgeräte Marica EOOD

4202 Radinovo

Bezirk Plovdiv

Bulgarien

home.liebherr.com