

---

# LH 22 Industry Litronic

---

## LIEBHERR

Material handling machine

### Generation

6

### Operating weight

19,200–22,200 kg\*

### Engine

105 kW / 143 HP

Stage V

Stage IIIA (compliant)

Tier 4 Final

\* Without attachment



## Performance

Power plus speed –  
Redefined performance

## Economy

Good investment –  
Savings for long-term

## Reliability

Durability and sustainability –  
Quality down to the last detail

## Comfort

Perfection at a glance –  
When technology is comfortable

## Maintainability

Efficiency bonus –  
Even with maintenance and service





## **LH 22 M** **Industry Litronic**

**Operating weight**

19,200–21,900 kg\*

**Engine**

105 kW / 143 HP

Stage V

Stage IIIA (compliant)

Tier 4 Final

## **LH 22 C** **Industry Litronic**

**Operating weight**

21,000–22,200 kg\*

**Engine**

105 kW / 143 HP

Stage V

Stage IIIA (compliant)

Tier 4 Final

\* Without attachment

# Performance

---



## Power plus speed – Redefined performance

Liebherr has been designing and manufacturing successful machines for material handling for over 60 years. With the different versions of the LH 22 Industry machine model of the generation of Liebherr handlers, high performance and yet economical machines specially designed for use in waste and scrap recycling.

## Maximum handling capacity

### High engine performance

The optimized design of the 105 kW engine supplies a high torque output for fast and strong movements. Load peaks are cleverly compensated for to ensure that maximum torque is available at all times for highest handling capacity.

### High load capacities

The intelligent arrangement of the components in the up-percarriage concept optimises the centre of gravity of the complete machine. This allows greater load capacities while retaining compact dimensions.

### Captivating dynamics

The combination of an increased engine output and a higher pump delivery volume guarantees maximum acceleration and speed of working motions.

## Precision operation

### Intelligent electronics

The elaborate machine controls guarantee that the hydraulics are optimally configured for the task at hand. Here, the load sensing control ensures that the flow delivered by the pump is optimally distributed when movements overlap. Speed and power are available whenever they are needed.

### Sensitive hydraulics

The optimal harmonisation between the engine and the control valve allows a fast and direct response from the hydraulics to the input command. This is controlled proportionally to enable smooth and gentle movements to be executed when the joystick is moved.

### Firm and stable positioning

An essential prerequisite for precise working and maximum handling capacity is the firm and stable positioning of the machine. The design of the Liebherr undercarriage optimises the way forces are induced on components to minimise stress and guarantee maximum stability and durability.



### Liebherr diesel engine

- Powerful, robust and reliable
- Maximum torque even at low speeds to ensure fast movements with low fuel consumption
- Common-Rail injection system for maximum efficiency



### Generator

- Twin-belt drive for good functional reliability
- High efficiency thanks to direct transmission of the engine torque
- Optimised belt guidance for long service life



### Travel motor

- Powerful, robust, reliable and quiet
- Better performance even on uphill grades due to electrical swivel angle adjustment for more torque, maximum acceleration and more driving power
- Fuel efficiency at maximum speed due to optimal adjustment of speed and delivery volume

# Economy

---



## Good investment – Savings for long-term

Liebherr material handling machines combine high productivity with excellent economy – all as standard. Liebherr manages to achieve this difficult goal through sophisticated engine technology from its own production and improved demand-controlled hydraulics.

# Fuel efficiency

## Requirement-controlled cooling

The vanes of the fan are driven regardless of the diesel engine, generating the exact cooling output that is actually required. Thermal sensors guarantee reliable, need-based and efficient control.

## Engine idling and engine shut-down

The standard automatic idling function reduces the engine speed to idle as soon as the operator takes their hand from the joystick so that no hydraulic function is activated. Proximity sensors in the joystick levers restore the original engine speed as soon as the operator's hand is moved towards the lever again. This ensures that the set engine speed is available immediately. The result is a combination of fuel saving and reduced noise levels. Operating costs can be reduced even further with the optional automatic engine shut-down function.

# Increased productivity

## Attachments and quick coupling systems

Liebherr offers a wide selection of attachments for every application to increase the productivity of its material handling machines. In addition the material handlers can be fitted with a Liebherr quick coupling system which increases the productivity of the machine by up to 30%. The matching attachment and quick coupling system combined with the outstanding dynamics of a Liebherr handler ensures highest handling capacity and maximum productivity.

## Road licensing

The LH 22 M Industry with an adjustable boom package and the appropriate machine configuration can be issued with a road licence ex-works by the TÜV. This road licence enables it to work at the side of the road and to be driven to nearby places without the requirement for a special licence.

Liebherr Power Efficiency (LPE) System

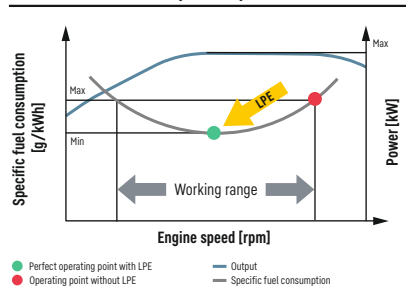

## Low fuel consumption thanks to intelligent machine control

- Liebherr-Power Efficiency (LPE) optimises the interaction of the drive components in terms of efficiency
- LPE enables machine operation in the area of the lowest specific fuel use for less consumption and greater efficiency with the same performance

## Liebherr attachments

- Robust and service-friendly slewing drive, can be turned 360°
- Optimum filling and clamping performance for effective material handling
- Finite element method (FEM) optimised for a perfect relationship between grapple weight, volume and a very long service life

## Eco-mode

- Reducing the engine speed by pressing a button
- Lower fuel consumption with unchanged high performance
- Economical and environmentally friendly working guaranteed
- Ideal for light to medium operations

# Reliability

---



## Durability and sustainability – Quality down to the last detail

Every day Liebherr material handlers show their qualities in a very wide range of industrial applications all over the world. Years of experience, continuous development and the latest technologies provide maximum safety in use. Their robust, compact design and the use of components produced in-house ensure that the material handling machine LH 22 is designed for a long service life.



## More safety

### Pipe fracture safety valves

The standard pipe fracture safety valves on the stick and hoist cylinders prevents the equipment from dropping in an unregulated way and ensure maximum safety during every operation.

### Working range limiters

For operations in which the working range should be limited, the material handling machines can be equipped optional with a working range limitation feature. Collisions and resulting component damage can thus be avoided.

### Overload warning device and load torque limitation

The acoustic and visual overload warning system continuously tells the operator about the current load situation of the machine. Furthermore, load torque limitation automatically regulates the speed of the working hydraulics to allow the maximum load bearing capacity to be approached safely. In the event of an overload, the functions which could cause the machine to topple are disabled. Only movements back to the safe working range are then possible.

## High machine availability

### Quality and competence

Our experience, understanding of customer needs and the technical implementation of these findings guarantee the success of the product. For decades, Liebherr has been inspirational with its depth of production and system solutions. Key components such as the diesel engine, electronic components, slewing ring, swivelling drive and hydraulic cylinders are developed and produced by Liebherr itself. The great depth of in-house manufacturing guarantees maximum quality and ensures that components are optimally configured to each other.

### Robust design

All steel components are designed and manufactured by Liebherr itself. High-strength steel plates configured for the toughest of requirements result in high torsional stiffness and optimum absorption of forces induced for a longer service life.

### Intelligent self diagnostics

The clever control electronics permanently monitor the vital functions of the machine to guarantee a high level of machine availability. Components which are critical for safety are designed with redundancy to guarantee maximum reliability.



### QPDM – Quality and process data management

- QPDM allows production data to be logged, documented and evaluated
- Test specifications and machine documented automatically logged
- Ability to handle large quantities of data while maintaining uniform high quality



### Dust-intensive jobs

- Large-dimension radiator with large mesh for optimum cooling performance, even in extremely dust-intensive conditions
- Protective grille with fine mesh, extending and folding fan for quick and easy cleaning
- Provision for the installation of filter systems on the cab



### Recycling package

- Reversible fan slows down the accumulation of dirt in the engine and radiator, guaranteeing high levels of machine availability
- Separate position of air conditioning compressor maximises the air stream in the radiator / fan unit and guarantees good reliability even in extremely dust-intensive conditions
- Air pre-filter with dust discharge for extra-fine filtration of the engine intake air

# Comfort

---



## Perfection at a glance – When technology is comfortable

The Liebherr deluxe cab is spacious, has an ergonomic design and is very quiet. This ensures that the operator remains intent and fully concentrated throughout the working day and enables him to deliver a constantly high performance.

## Deluxe cab

### Ergonomic design

The modern cab design provides excellent conditions for healthy, concentrated and productive work in maximum comfort. The colour touchscreen display, the controls and operator's seat Comfort are all coordinated to form a perfect ergonomic unit. In addition the ergonomic joysticks allow the machine operation to be both pleasant and precise.

### Excellent all-round vision

The large areas of glass, different versions of cab elevations and the rear and side area monitoring systems provide the operator with an excellent view of his working area and the zone around the machine. This perfect view enhances the operator's safety and ensures that he can handle the machine safely at all times.

### Low noise levels

The use of viscoelastic mounts, good insulation and low-noise diesel engines from Liebherr minimises noise emissions and vibrations.



### Safe access

- Foldable arm console for a safe and comfortable access
- Wide, non-slip steps and ergonomically positioned handles for an easy and safe access
- All access systems are designed to national guidelines and statutory regulations
- Elastic first step



### Operator's seat comfort with adjustable armrests

- Greater seating comfort due to variable damper hardness, lockable horizontal suspension, pneumatic lumbar support, seat heating and passive seat air conditioning for concentrated working
- Individual adjustment options for armrests, seat cushion depth, seat angle and head restraint for comfortable working

## Comfortable operation

### Proportional control

Precision control of the material handling machine are especially important in applications such as waste separation or scrap recycling. Thanks to the standard proportional control, even such demanding operations can be mastered in style.

### Joystick steering and stabilizing

The standard joystick steering gives the operator an additional comfort boost. The steering movement can be conveniently executed using the joystick, eliminating the need to reposition during the work cycle. Substituting the steering wheel in favour of joystick steering provides additional legroom and a clear view of the working area. A new standard feature is Joystick control of the outriggers for more convenience and an increased productivity.

### Colour touchscreen display and operation unit

The 9" colour touchscreen display is intuitive in its operation and provides continuous information about all important operating data. The shortcut keys can be individually assigned and are selected quickly and easily with the menu strip.



### Joystick with proportional control

- Good functionality with streamlined, ergonomic design
- 4-way mini joystick can be used to control all operations e.g. steering, outriggers and attachments etc.
- Joysticks - each with two newly designed buttons and a rocker switch - increase the number of functions available

# Maintainability



## Efficiency bonus – Even with maintenance and service

The Liebherr material handling machine LH 22 is powerful, robust, precise and efficient. It also features integral maintenance benefits as a result of their service-based machine design. The maintenance work for the Liebherr material handler can be carried out quickly, easily and safely. This minimises the material handling machine's maintenance costs and down times.

## Elaborate maintenance concept

### Service-based machine design

The service-based machine design guarantees short servicing times, thus minimising maintenance costs due to the time it saves. All the maintenance points are easily accessible from the ground and easy to reach due to the large, wide-opening service doors. The enhanced service concept places the maintenance points close to each other and reduces their number to a minimum. This means that service work can be completed even more quickly and efficiently.

### Integral maintenance benefits

Maintenance work helps to keep the machine fully functional. However this kind of work leads to machine downtimes which must be minimised. With change intervals of up to 500 hours for engine oil and up to 8,000 hours for hydraulic oil, Liebherr has significantly reduced the amount of maintenance and increased the productivity of the material handlers. In addition, central lubrication systems minimise daily maintenance.

## Your competent service partner

### Remanufacturing

The Liebherr remanufacturing program offers cost-effective reconditioning of components to the highest quality standards. Various reconditioning levels are available: Replacement components, general overhaul or repair. The customer receives components with original part quality at a reduced cost.

### Competent advice and service

Competent advice is given at Liebherr. Experienced specialists provide decision guidance for your specific requirements: application-oriented sales support, service agreements, economical repair alternatives, original parts management, as well as remote data transmission for machine planning and fleet management.

### Fast spare parts service

The Liebherr spare parts service provides 24-hour delivery and is therefore available to our dealers around the clock. Thanks to the electronic spare parts catalogue, the parts can be selected and ordered quickly and reliably using the Liebherr online portal. Your order can be tracked at any time using the online tracking system.



### Lubrication as it works

- Fully automatic central lubrication system for uppercarriage and equipment
- Can be extended as an option to the connection link, quick coupler and attachment
- Fully automatic central lubrication system for the undercarriage available as an option
- Lubricates without interrupting work to ensure better productivity and a long component service life



### Excellent service access

- Large, wide-opening service doors
- Engine oil, fuel, air and cab air filters are easily and safely accessible from the ground
- The oil level in the hydraulic tank can be checked from the cab
- Short service times for more productivity



### SCRT for stage V

- Developed emissions purification system SCRT includes a DOC catalytic converter, a particulate filter and an SCR catalytic converter
- The DOC catalytic converter requires no maintenance and the particulate filter is actively regenerated
- The maintenance intervals can be extended to 3,000 hours of service

# Material handling machines overview

## Equipment

- High load capacities and long reaches thanks to optimised kinematic properties and robust construction for greater handling performance
- Ingenious routing of hydraulic hoses optimises the oil flow and minimises power losses for maximum energy efficiency
- Pipe fracture safety valves on hoist and stick cylinders and retract stick shut-off for maximum safety during every application
- Quick coupling systems and attachments made by Liebherr for maximum machine capacity utilisation and greater handling performance

## Operator's cab

- Joystick steering without steering column as standard for convenient operation, greater legroom and clear view of the working area
- Less strain on the operator, workers and reduced environmental pollution due to lower noise emissions
- Optimum visibility thanks to large glass surfaces and standard rear and side area monitoring with camera
- Proportional control as standard with 4-way mini joystick for greater precision, high precision control and functions





## Uppercarriage

- Greater fuel efficiency thanks to the latest engine technology with intelligent machine control
- Recycling package for high levels of machine availability even in extremely dust-intensive conditions
- Ideal uppercarriage concept for greater load capacities and optimum service access
- Optimised hydraulics for greater fuel efficiency and faster work cycles

## Undercarriage

- Maximum acceleration and higher drawbar pull thanks to the travel motor for greater travelling performance
- Load-holding valves fitted as standard on all support cylinders for maximum stability in every application
- Fewer downtimes thanks to maintenance-free support cylinders
- Undercarriage variants with dozer blade for universal operation of the material handling machine

# The perfect solution for every application

## Attachments

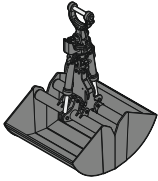

Grab for loose material

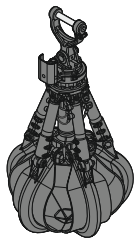

Multi-tine grab

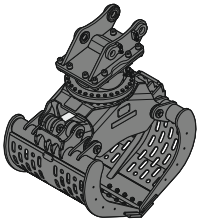

Sorting grab

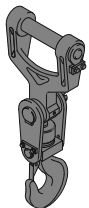

Load hook

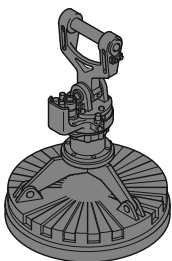

Magnet devices

## Sticks

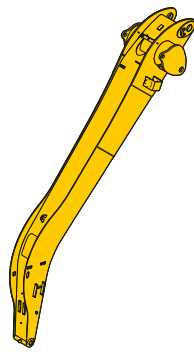

Angled stick

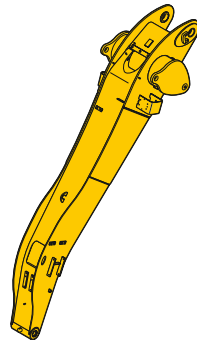

Flat angled stick

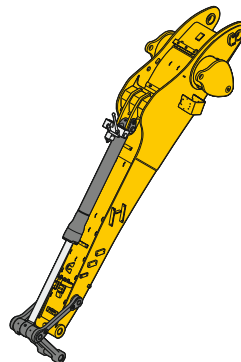

Stick with tipping kinematics

## Booms

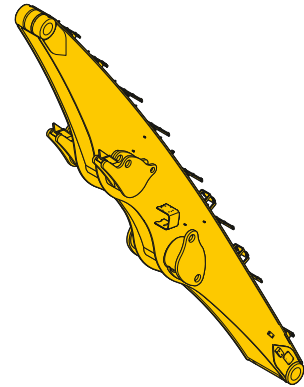

Straight boom

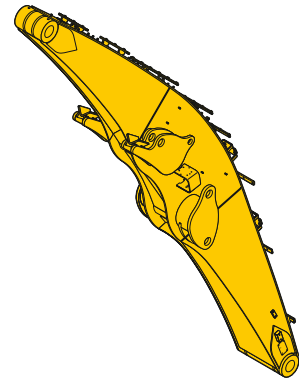

Angled boom

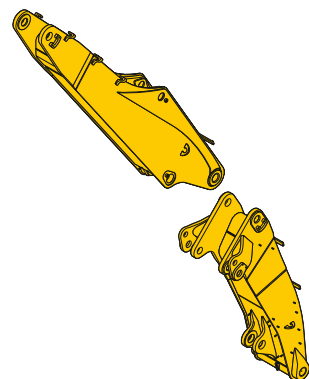

Two-piece boom



## Cab elevations

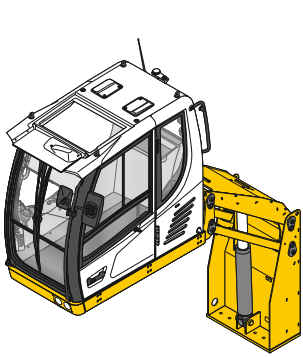

Hydraulic cab elevation

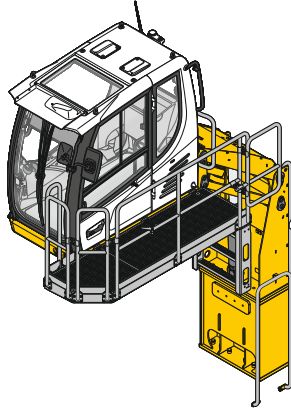

Connecting piece for hydraulic cab elevation

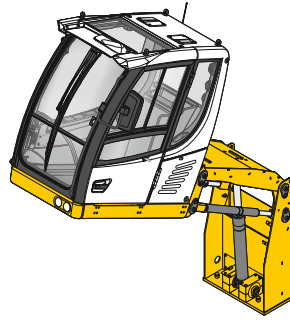

30° tilt function

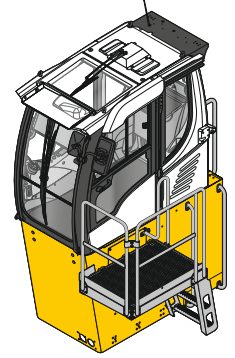

Rigid cab elevation

---

## Uppercarriage

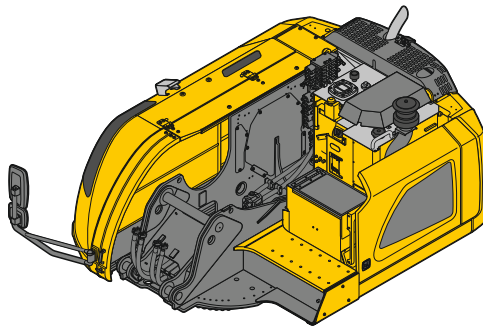

---

## Undercarriage

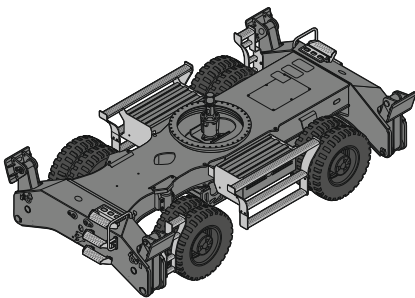

Mobile, 4 point outriggers

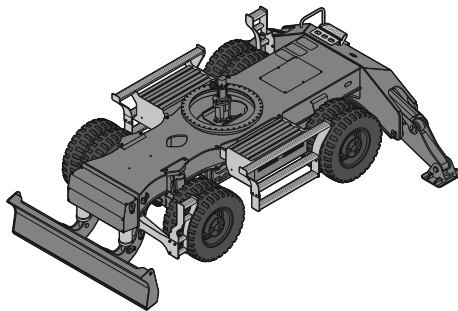

Mobile, blade + 2 point outriggers

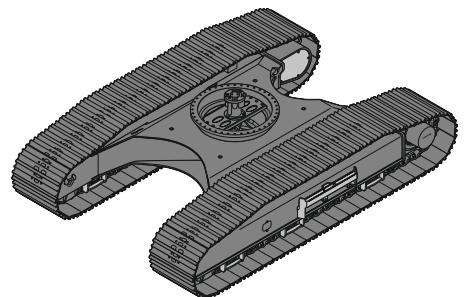

Crawler

# Experience the progress

The invention of the mobile tower crane in 1949 also marked the birth of the Liebherr company. During its first decade the small construction company developed into an established manufacturer of construction machines and other technically advanced products. The R 353 and its first industrial equipment were launched in 1951 to lay the

foundations for the production of today's material handling machines. The A 911 mobile material handling machine a few years later enabled the company to make the breakthrough into material handling. Over the years the machines have been developed continually and today they are designed uncompromising for the industrial use.

**1949**

First tower crane TK10



**1968**

Breakthrough with the A 911 mobile material handler



**1974**

Silenced material handling machine



R 353 with the first industrial equipment

**1961**



Production plant in Kirchdorf

**1970**



First hydraulic cab elevation

**1983**

Liebherr has now been developing and manufacturing material handling machines for a very wide range of applications in the scrap, port and timber handling sectors and for the waste and recycling industry for over 60 years. In the development of its machines, Liebherr chooses quality, durability and reliability from the very outset, together with performance and economy. Years of experience in design

and construction are not only reflected in the end product but also in the components which are developed, designed and manufactured by Liebherr itself. This multiple sector expertise is used in product design from the early phase of the development process and thus allows high level technical innovations to be made.

**2007**

Opening of the assembly building for material handling machines



**2013**

Launch of the new LH series



**2016**

Launch of the new Port Material handling machines



Awarded the Bauma Design Prize for the LH 120

**2010**



Awarded the Bauma Innovation Prize for the ERC cylinder



Awarded the IF Award for the material handling machine LH 60

**2014**

# Technical data



## Diesel engine

<b>Rating per ISO 9249</b>	105kW (143HP) at 1,800RPM
<b>Model</b>	
Stage V / Tier 4 Final	D924 - FPT motor designed for Liebherr
Stage IIIA (compliant)	Cummins QSB4.5
<b>Type</b>	4 cylinder in-line
Bore / Stroke	104 / 132 mm (FPT) 107 / 124 mm (Cummins)
Displacement	4.5l
<b>Engine operation</b>	4-stroke diesel Common-Rail Turbo-charged and after-cooled Reduced emissions
<b>Air cleaner</b>	Dry-type air cleaner with pre-cleaner, primary and safety elements
<b>Engine idling</b>	Sensor controlled
<b>Electrical system</b>	
Voltage	24 V
Batteries	2 x 135 Ah / 12V
Alternator	Three-phase current 28V / 140 A (FPT) Three-phase current 28V / 90 A (Cummins)
<b>Stage V</b>	
Harmful emissions values	According to regulation (EU) 2016/1628
Emission control	Liebherr-SCRT technology
Fuel tank	369 l
Urea tank	46 l
<b>Stage IIIA (compliant)</b>	
Harmful emissions values	In accordance with ECE-R.96 Power Band I
Fuel tank	369 l
<b>Tier 4 Final</b>	
Harmful emissions values	In accordance with 40CFR1039 (EPA) / 13CCR (CARB)
Emission control	Liebherr-SCR technology
Fuel tank	369 l
Urea tank	46 l



## Cooling system

<b>Diesel engine</b>	Water-cooled Compact cooling system consisting cooling unit for water, hydraulic oil and charge air with stepless thermostatically controlled fan, fans for radiator cleaning can be completely folded away
----------------------	--



## Hydraulic controls

<b>Power distribution</b>	Via control valves with integrated safety valves, simultaneous and independent actuation of chassis, swing drive and equipment
<b>Servo circuit</b>	
Equipment and swing	With hydraulic pilot control and proportional joystick levers
Chassis mobile	Electro-proportional via foot pedal
Chassis crawler	With hydraulic proportionally functioning foot pedals or adjusted with plugable levers
<b>Additional functions</b>	Via switch or electro-proportional foot pedals
Proportional control	Proportionally acting transmitters on the joysticks for additional hydraulic functions



## Hydraulic system

<b>Hydraulic pump</b>	For equipment and travel drive Liebherr axial piston variable displacement pump
Max. flow	300l/min.
Max. pressure	350 bar
<b>Hydraulic pump regulation and control</b>	Liebherr-Synchron-Comfort-system (LSC) with electronic engine speed sensing regulation, pressure and flow compensation, torque controlled swing drive priority
<b>Hydraulic tank</b>	155 l
<b>Hydraulic system</b>	350 l
<b>Filtration</b>	1 main return filter with integrated partial micro filtration (5 µm)
<b>MODE selection</b>	Adjustment of engine and hydraulic performance via a mode pre-selector to match application, e.g. for especially economical and environmentally friendly operation or for maximum material handling and heavy-duty jobs
S (Sensitive)	Mode for precision work and lifting through very sensitive movements
E (Eco)	Mode for especially economical and environmentally friendly operation
P (Power)	Mode for high performance with low fuel consumption
P+ (Power-Plus)	Mode for highest performance and for very heavy duty applications, suitable for continuous operation
<b>Engine speed and performance setting</b>	Stepless alignment of engine output and hydraulic power via engine speed
Option	Tool Control: 20 pre-adjustable pump flows and pressures for add-on attachments



## Swing drive

<b>Drive</b>	Liebherr axial piston motor with integrated brake valve and torque control
<b>Swing ring</b>	Liebherr, sealed race ball bearing swing ring, internal teeth
<b>Swing speed</b>	0-9.0RPM stepless
<b>Swing torque</b>	53 kNm
<b>Holding brake</b>	Wet multi-disc (spring applied, pressure released)
<b>Option</b>	Slewing gear brake Comfort

## Cab

<b>Cab</b>	TOPS safety cab structure (tip-over protection) with individual windscreens or featuring a slide-in subpart under the ceiling, work headlights integrated in the ceiling, a door with a sliding window (can be opened on both sides), large stowing and depositing possibilities, shock-absorbing suspension, sound damping insulating, tinted laminated safety glass, separate shades for the sunroof window and windscreen
<b>Operator's seat Comfort</b>	Air cushioned operator's seat with 3D-adjustable armrests, headrest, lap belt, seat heater, adjustable seat cushion inclination and length, lockable horizontal suspension, automatic weight adjustment, adjustable suspension stiffness, pneumatic lumbar vertebrae support and passive seat climatisation with active coal
<b>Operator's seat Premium (Option)</b>	In addition to operator's seat comfort: active electronic weight adjustment (automatic readjustment), pneumatic low frequency suspension and active seat climatisation with active coal and ventilator
<b>Arm consoles</b>	Joysticks with control consoles and swivel seat, folding left control console
<b>Operation and displays</b>	Large high-resolution operating unit, self-explanatory, colour display with touchscreen, video-compatible, numerous setting, control and monitoring options, e.g. air conditioning control, fuel consumption, machine and attachment parameters
<b>Air-conditioning</b>	Automatic air-conditioning, recirculated air function, fast de-icing and demisting at the press of a button, air vents can be operated via a menu; recirculated air and fresh air filters can be easily replaced and are accessible from the outside; heating-cooling unit, designed for extreme outside temperatures, sensors for solar radiation, inside and outside temperatures
Refrigerant	R134a
Global warming potential	1,430
Quantity at 25 °C*	1,300–1,500 g
CO <sub>2</sub> equivalent	1.859–2.145 t
<b>Vibration emission**</b>	
Hand / arm vibrations	< 2.5 m/s <sup>2</sup>
Whole-body vibrations	< 0.5 m/s <sup>2</sup>
Measuring inaccuracy	According with standard EN 12096:1997

## Equipment

<b>Type</b>	High-strength steel plates at highly-stressed points for the toughest requirements. Complex and stable mountings of equipment and cylinders
<b>Hydraulic cylinders</b>	Liebherr cylinders with special sealing and guide system and, depending on cylinder type, shock absorption
<b>Bearings</b>	Sealed, low maintenance

## Undercarriage

<b>Mobile</b>	
Drive	Oversized two speed power shift transmission with additional creeper speed, Liebherr axial piston motor with functional brake valve on both sides
Travel speed	0– 3.5 km/h stepless (creeper speed + transmission stage 1)
Joystick steering	0– 7.0 km/h stepless (transmission stage 1) 0–12.0 km/h stepless (creeper speed + transmission stage 2) 0–12.0 km/h stepless (transmission stage 2)
Travel speed	0– 3.5 km/h stepless (creeper speed + transmission stage 1)
Wheel steering (Option)	0– 7.0 km/h stepless (transmission stage 1) 0–13.0 km/h stepless (creeper speed + transmission stage 2) 0–20.0 km/h stepless (transmission stage 2)
Driving operation	Automotive driving using accelerator pedal, cruise control function: storage of variable accelerator pedal positions
Axles	32 t drive axles; manual or automatic hydraulically controlled front axle oscillation lock
Service brake	Two circuit travel brake system with accumulator; wet and backlash-free disc brake
Holding brake	Wet multi-disc (spring applied, pressure released)
Stabilization	Stabilizing blade + 2 point outriggers 4 point outriggers Dozer blade, at the front, for 4 point outriggers
Option	
<b>Crawler</b>	
Version	LC
Drive	Liebherr compact planetary reduction gear with Liebherr axial piston motor per side of undercarriage
Travel speed	0–2.7 km/h stepless (creeper speed) 0–4.6 km/h stepless
Brake	Functional brake valves on both sides
Holding brake	Wet multi-disc (spring applied, pressure released)
Track pads	Triple grouser

## Complete machine

<b>Lubrication</b>	Liebherr central lubrication system for uppercarriage and equipment, automatically
Mobile (Option)	Liebherr central lubrication system for undercarriage, automatically
<b>Steps system</b>	Safe and durable access system with anti-slip steps; main components hot-galvanised
<b>Noise emission</b>	
ISO 6396 (Stage V)	70 dB(A) = L <sub>PA</sub> (inside cab)
2000/14/EC (Stage V)	101 dB(A) = L <sub>WA</sub> (surround noise)
ISO 6396 (Stage IIIA compliant)	70 dB(A) = L <sub>PA</sub> (inside cab)
2000/14/EC (Stage IIIA compliant)	102 dB(A) = L <sub>WA</sub> (surround noise)
ISO 6396 (Tier 4 Final)	70 dB(A) = L <sub>PA</sub> (inside cab)
2000/14/EC (Tier 4 Final)	101 dB(A) = L <sub>WA</sub> (surround noise)

\* depending on configuration

\*\* for risk assessment according to 2002/44/EC see ISO/TR 25398:2006

# LH 22 M – Dimensions

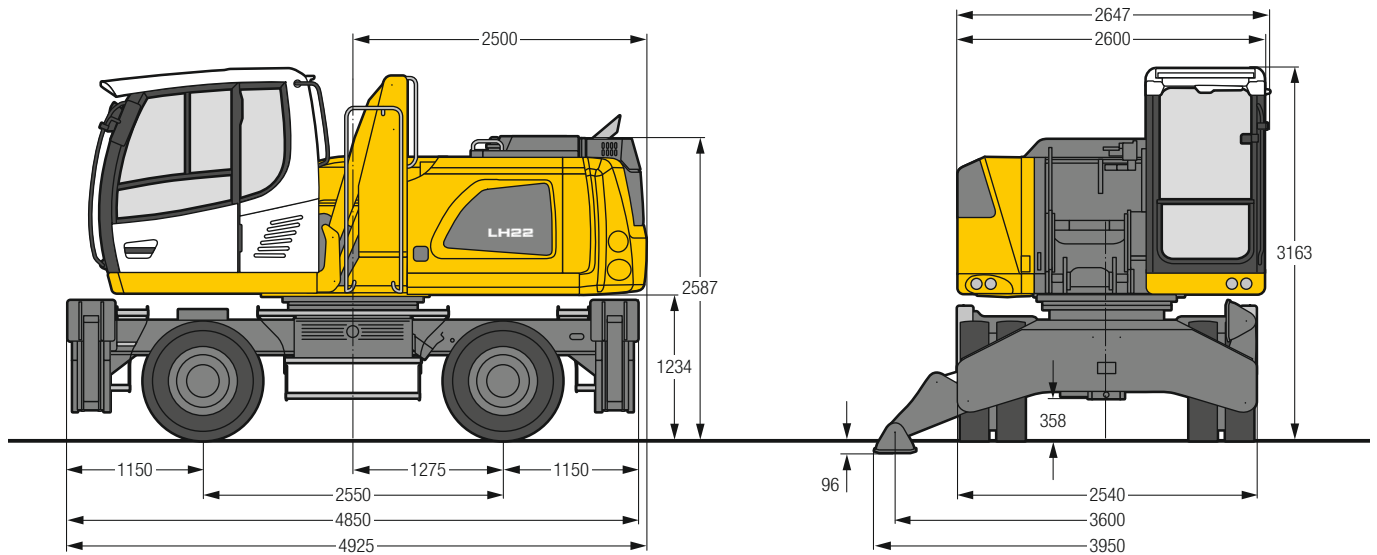

## LH 22 M – Choice of cab elevation

### Cab elevation LFC (rigid elevation)

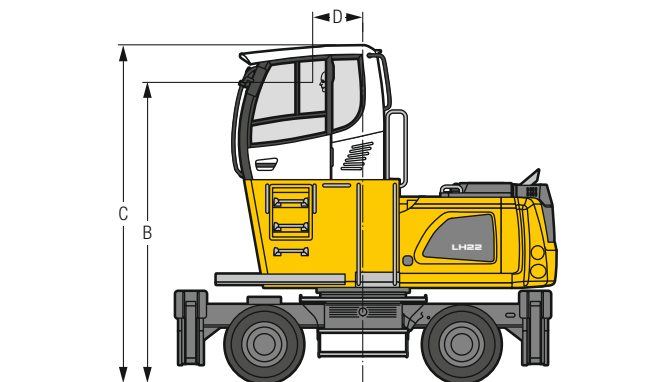

Increase type	LFC 120
Height	1,200 mm
B	3,889 mm
C	4,361 mm
D	653 mm

A rigid cab elevation has a fixed eye level height. For a lower transport height, the shell of the cab can be removed and replaced by a transport device. The dimension C is in this machine design for all rigid cab elevations 3,465 mm.

### Cab elevation LHC (hydraulic elevation)

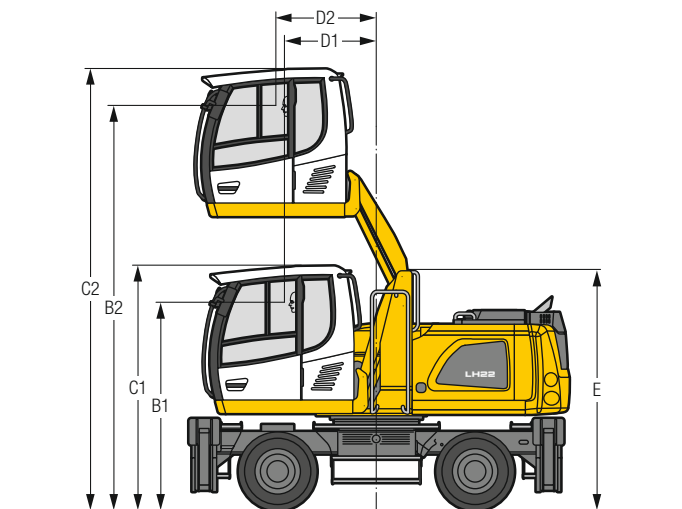

Increase type	LHC 255
B1	2,696 mm
B2	5,236 mm
C1	3,163 mm
C2	5,704 mm
D1	1,190 mm
D2	1,299 mm
E	3,104 mm

The hydraulically adjustable cab allows the driver, that he can choose his field of view freely and at any time within the stroke.

Tyres 10.00-20

# LH 22 C – Dimensions

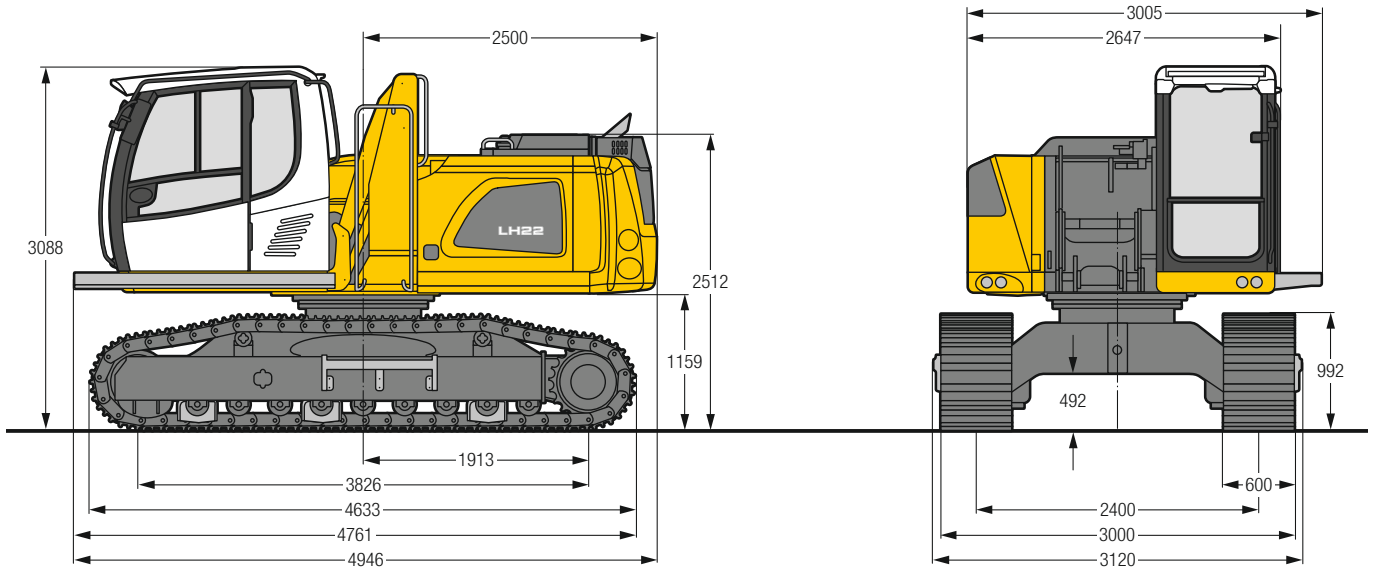

# LH 22 C – Choice of cab elevation

## Cab elevation LFC (rigid elevation)

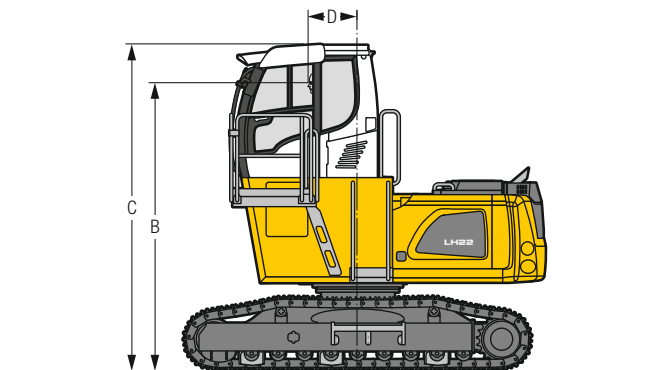

Increase type	LFC 120
Height	1,200 mm
B	3,814 mm
C	4,328 mm
D	653 mm

A rigid cab elevation has a fixed eye level height. For a lower transport height, the shell of the cab can be removed and replaced by a transport device. The dimension C is in this machine design for all rigid cab elevations 3,432 mm.

## Cab elevation LHC (hydraulic elevation)

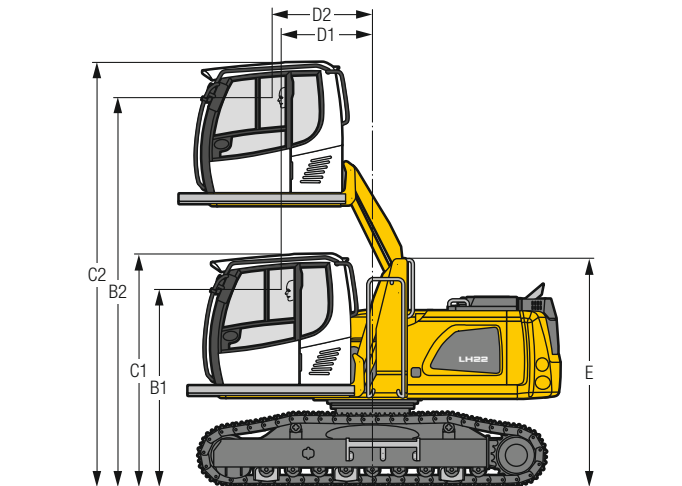

Increase type	LHC 255
B1	2,621 mm
B2	5,161 mm
C1	3,088 mm
C2	5,629 mm
D1	1,207 mm
D2	1,317 mm
E	3,029 mm

The hydraulically adjustable cab allows the driver, that he can choose his field of view freely and at any time within the stroke.

# LH 22 M – Equipment GA10

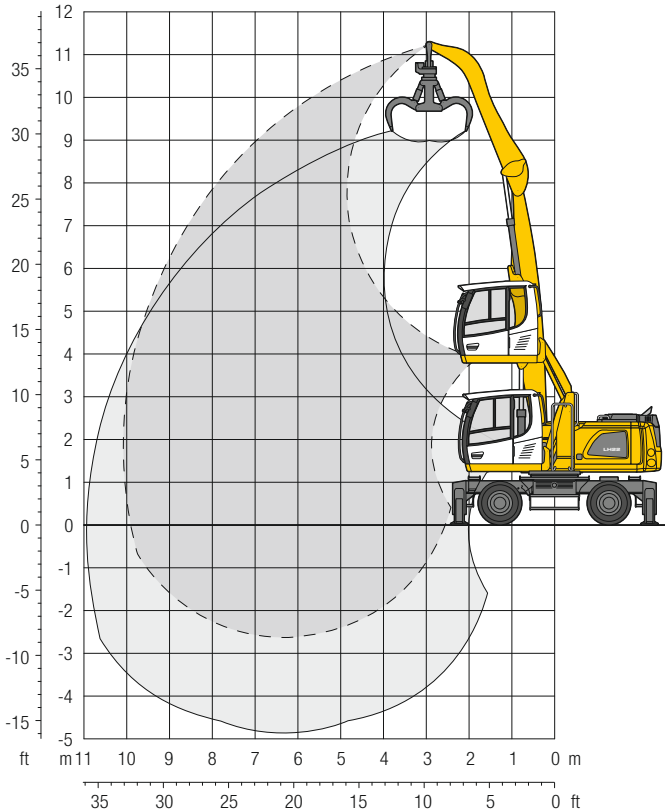

## Dimensions

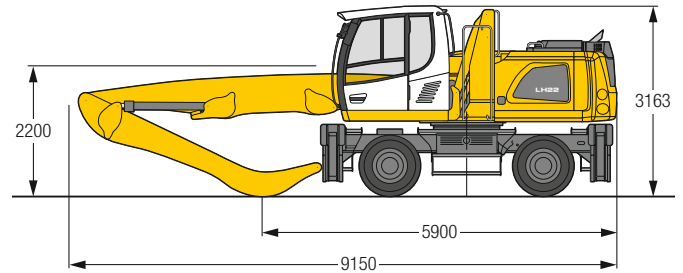

## Operating weight

The operating weight includes the basic machine with 4 point outriggers, hydr. cab elevation, 8 solid tyres plus intermediate rings, straight boom 6.00 m, angled stick 4.00 m and multi-tine grab GM 55B / 0.40 m<sup>3</sup> semi-closed tines.

Weight 22,500 kg

m	3.0m		4.5m		6.0m		7.5m		9.0m		10.5m		m
10.5	Undercarriage		5.6*		5.6*								4.8
	Stabilizers raised		5.6*		5.6*								4.8
	4 pt. outriggers down		5.6*		5.6*								4.8
9.0	Stabilizers raised				3.9		5.1						7.0
	4 pt. outriggers down				5.6*		5.6*						7.0
7.5	Stabilizers raised				3.9		5.2		2.7		3.6		8.3
	4 pt. outriggers down				5.7*		5.7*		4.9*		4.9*		8.3
6.0	Stabilizers raised				6.0		7.2*		2.0		2.6		9.1
	4 pt. outriggers down				7.2*		7.2*		3.9*		3.9*		9.1
4.5	Stabilizers raised				5.6		7.6		1.9		2.6		9.7
	4 pt. outriggers down				7.8*		7.8*		4.0		4.2*		9.7
3.0	Stabilizers raised		9.1		5.1		7.1		1.9		2.6		10.0
	4 pt. outriggers down		11.8*		8.6*		8.6*		3.9		4.1*		10.0
1.5	Stabilizers raised		1.2*		4.6		6.5		1.8		2.5		10.1
	4 pt. outriggers down		1.2*		8.9*		8.9*		3.9		3.9*		10.1
0	Stabilizers raised		1.9*		4.4		6.2		1.8		2.4		9.9
	4 pt. outriggers down		1.9*		7.9*		7.9*		3.5*		3.5*		9.9
-1.5	Stabilizers raised				4.3		6.1		1.8		2.4		9.1
	4 pt. outriggers down				6.5*		6.5*		2.6*		2.6*		9.1
-3.0	Stabilizers raised												
	4 pt. outriggers down												

Height Can be slewed through 360° In longitudinal position of undercarriage Max. reach \* Limited by hydr. capacity

The lift capacities on the stick end without attachment are stated in metric tons (t) and are valid on a firm, level supporting surface with blocked oscillating axle. These capacities can be slewed through 360° with the undercarriage in the transverse position. Capacities in the longitudinal position of the undercarriage (±15°) are specified over the steering axle with the stabilizers raised and over the rigid axle with the stabilizers down. Indicated loads based on the ISO 10567 standard and do not exceed 75% of tipping or 87% of hydraulic capacity. The lift capacity of the unit is limited by its stability, the lifting capability of the hydraulic elements, or the maximum permissible lifting capacity of the load hook.

In accordance with the harmonised European Standard EN 474-5, hydraulic excavators used for lifting operations must be equipped with pipe fracture safety valves, an overload warning device, a load hook and a lift capacity chart.



# LH 22 M – Equipment GA11

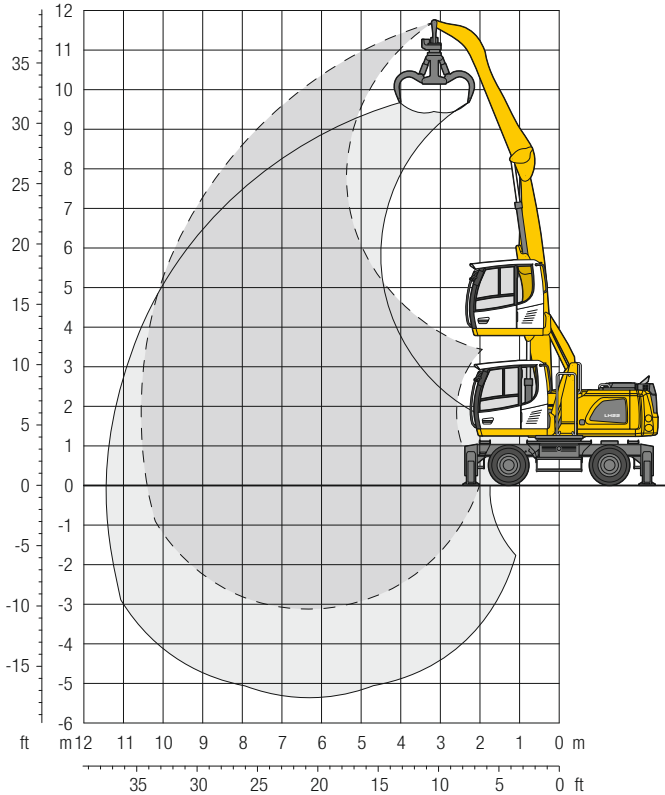

## Dimensions

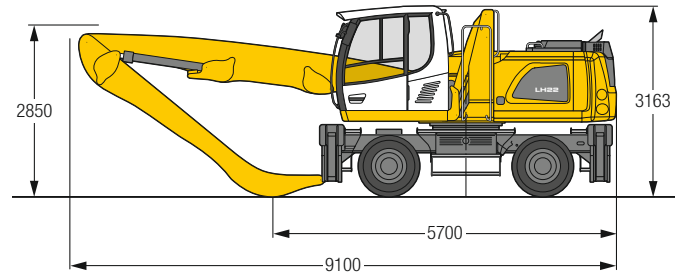

## Operating weight

The operating weight includes the basic machine with 4 point outriggers, hydr. cab elevation, 8 solid tyres plus intermediate rings, straight boom 6.00 m, angled stick 4.50 m and multi-tine grab GM 55B / 0.40 m<sup>3</sup> semi-closed tines.

Weight 22,600 kg

m	3.0m		4.5m		6.0m		7.5m		9.0m		10.5m		m	
10.5	Undercarriage		5.7*		4.0		2.7		2.0		1.5		4.0	4.1*
	Stabilizers raised		5.7*		5.5*		3.8*		4.1		2.0		4.1*	4.1*
	4 pt. outriggers down				5.2		3.6		2.7		2.0		3.4*	3.4*
9.0	Stabilizers raised				4.0		2.8		2.0		1.5		2.6	3.4*
	4 pt. outriggers down				5.5*		4.8*		4.1		2.0		3.4*	3.4*
7.5	Stabilizers raised				4.0		2.8		2.0		1.5		2.0	2.7
	4 pt. outriggers down				5.5*		4.8*		4.1		2.0		3.1*	3.1*
6.0	Stabilizers raised				3.9		2.7		2.0		1.5		1.7	2.4
	4 pt. outriggers down				5.6*		4.8*		4.1		2.0		3.0*	3.0*
4.5	Stabilizers raised		5.8		3.7		2.6		2.0		1.5		1.6	2.1
	4 pt. outriggers down		7.3*		5.9*		4.9*		4.0		2.0		2.9*	2.9*
3.0	9.7	12.7*	5.3	7.2	3.5	4.7	2.5	3.4	1.9	2.6	1.5	2.0	1.5	2.0
	12.7*	12.7*	8.3*	8.3*	6.3*	6.3*	5.0*	5.0*	4.0	4.1*	3.0*	3.0*	2.9*	2.9*
1.5	2.2*	2.2*	4.7	6.6	3.2	4.4	2.4	3.2	1.8	2.5	1.4	2.0	1.4	2.0
	2.2*	2.2*	8.8*	8.8*	6.4*	6.4*	5.0*	5.0*	3.9	4.0*	2.9*	2.9*	2.8*	2.8*
0	2.1*	2.1*	4.4	6.2	3.0	4.2	2.3	3.1	1.8	2.4	1.4	2.0	1.5	2.0
	2.1*	2.1*	8.5*	8.5*	6.2*	6.2*	4.8*	4.8*	3.7*	3.7*	2.9*	2.9*	2.5*	2.5*
-1.5	3.2*	3.2*	4.2	6.1	2.9	4.1	2.2	3.1	1.7	2.4	1.4	2.0	1.6	2.2
	3.2*	3.2*	7.2*	7.2*	5.5*	5.5*	4.2*	4.2*	3.0*	3.0*	2.9*	2.9*	2.3*	2.3*
-3.0	Stabilizers raised				2.9		2.3		1.7		1.4		2.3	3.1
	4 pt. outriggers down				4.1*		4.1*		3.0*		2.9*		3.2*	3.2*

Height Can be slewed through 360° In longitudinal position of undercarriage Max. reach \* Limited by hydr. capacity

The lift capacities on the stick end without attachment are stated in metric tons (t) and are valid on a firm, level supporting surface with blocked oscillating axle. These capacities can be slewed through 360° with the undercarriage in the transverse position. Capacities in the longitudinal position of the undercarriage (±15°) are specified over the steering axle with the stabilizers raised and over the rigid axle with the stabilizers down. Indicated loads based on the ISO 10567 standard and do not exceed 75% of tipping or 87% of hydraulic capacity. The lift capacity of the unit is limited by its stability, the lifting capability of the hydraulic elements, or the maximum permissible lifting capacity of the load hook.

In accordance with the harmonised European Standard EN 474-5, hydraulic excavators used for lifting operations must be equipped with pipe fracture safety valves, an overload warning device, a load hook and a lift capacity chart.

# LH 22 M – Equipment GK9

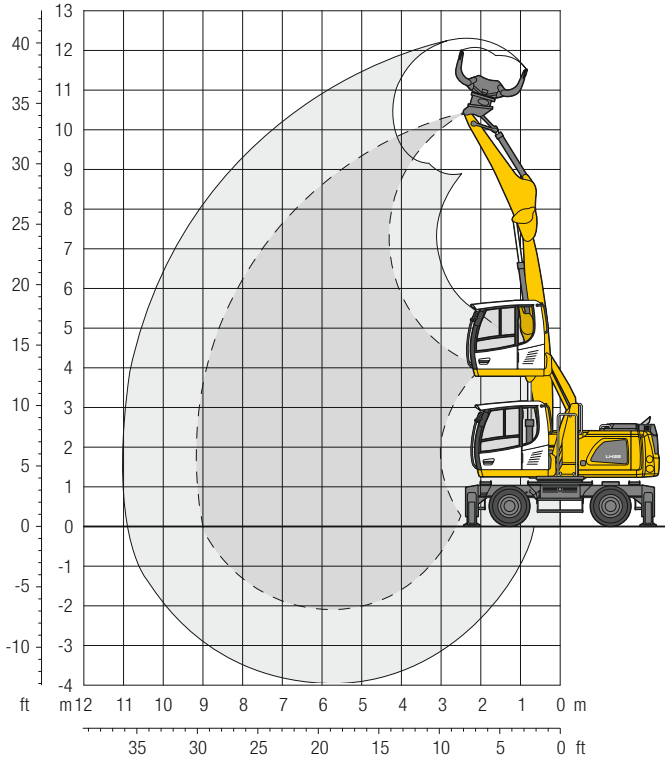

## Dimensions

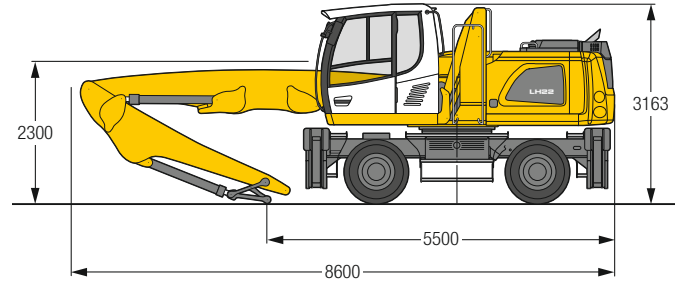

## Operating weight

The operating weight includes the basic machine with 4 point outriggers, hydr. cab elevation, 8 solid tyres plus intermediate rings, straight boom 5.50 m, stick with tipping kinematics 3.50 m and sorting grab SG 20B / 0.50 m<sup>3</sup> perforated shells.

Weight 22,700 kg

m	Undercarriage	3.0 m		4.5 m		6.0 m		7.5 m		9.0 m		10.5 m		m
10.5	Stabilizers raised													
	4 pt. outriggers down													
9.0	Stabilizers raised			5.7	7.1*							3.9	5.0*	5.5
	4 pt. outriggers down			7.1*	7.1*							5.0*	5.0*	
7.5	Stabilizers raised			5.8	7.1*	3.6	4.9					2.6	3.6	7.1
	4 pt. outriggers down			7.1*	7.1*	5.9*	5.9*					4.2*	4.2*	
6.0	Stabilizers raised			5.7	7.3*	3.6	4.8	2.4	3.3			2.1	2.9	8.1
	4 pt. outriggers down			7.3*	7.3*	5.9*	5.9*	4.9*	4.9*			3.8*	3.8*	
4.5	Stabilizers raised	7.6*	7.6*	5.4	7.4	3.5	4.7	2.4	3.3			1.8	2.5	8.8
	4 pt. outriggers down	7.6*	7.6*	7.8*	7.8*	6.1*	6.1*	4.9*	4.9*			3.7*	3.7*	
3.0	Stabilizers raised	9.0	13.3	5.0	6.9	3.2	4.5	2.3	3.2	1.7	2.4	1.7	2.3	9.1
	4 pt. outriggers down	13.5*	13.5*	8.6*	8.6*	6.3*	6.3*	4.9*	4.9*	3.7*	3.7*	3.5*	3.5*	
1.5	Stabilizers raised	0.9*	0.9*	4.5	6.4	3.0	4.2	2.2	3.1	1.7	2.3	1.6	2.3	9.2
	4 pt. outriggers down	0.9*	0.9*	8.7*	8.7*	6.3*	6.3*	4.8*	4.8*	3.3*	3.3*	3.1*	3.1*	
0	Stabilizers raised	2.0*	2.0*	4.3	6.1	2.9	4.1	2.1	3.0			1.7	2.3	9.0
	4 pt. outriggers down	2.0*	2.0*	7.9*	7.9*	5.8*	5.8*	4.2*	4.2*			2.5*	2.5*	
-1.5	Stabilizers raised			4.2	6.0*	2.8	4.0	2.1	3.0			2.0	2.9	7.7
	4 pt. outriggers down			6.0*	6.0*	4.6*	4.6*	3.1*	3.1*			2.9*	2.9*	

Height Can be slewed through 360° In longitudinal position of undercarriage Max. reach \* Limited by hydr. capacity

The lift capacities on the stick end without attachment are stated in metric tons (t) and are valid on a firm, level supporting surface with blocked oscillating axle. These capacities can be slewed through 360° with the undercarriage in the transverse position. Capacities in the longitudinal position of the undercarriage (±15°) are specified over the steering axle with the stabilizers raised and over the rigid axle with the stabilizers down. Indicated loads based on the ISO 10567 standard and do not exceed 75% of tipping or 87% of hydraulic capacity. The lift capacity of the unit is limited by its stability, the lifting capability of the hydraulic elements, or the maximum permissible lifting capacity of the load hook.

In accordance with the harmonised European Standard EN 474-5, hydraulic excavators used for lifting operations must be equipped with pipe fracture safety valves, an overload warning device, a load hook and a lift capacity chart.

# LH 22 M – Equipment GK10

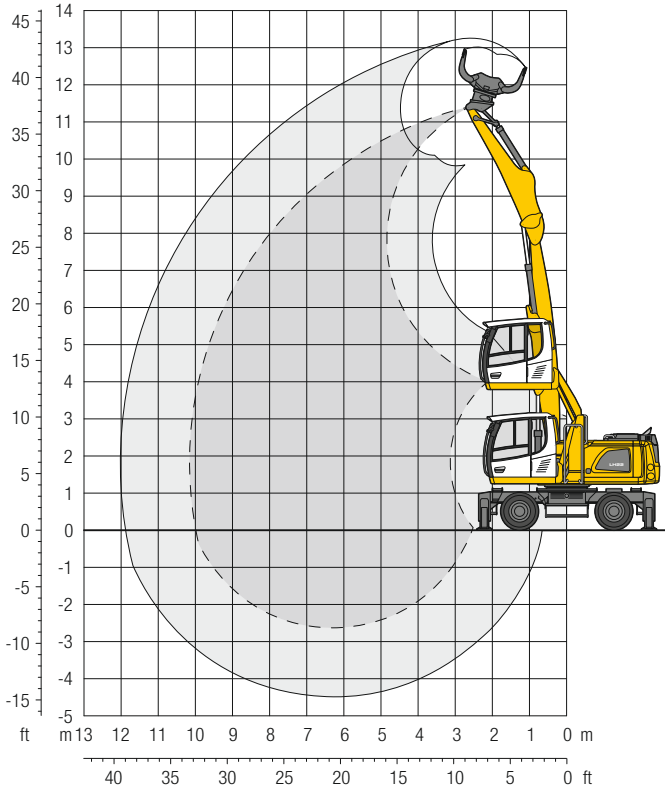

## Dimensions

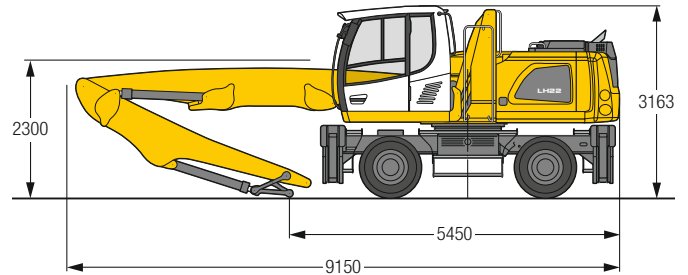

## Operating weight

The operating weight includes the basic machine with 4 point outriggers, hydr. cab elevation, 8 solid tyres plus intermediate rings, straight boom 6.00 m, stick with tipping kinematics 4.00 m and sorting grab SG 20B / 0.50 m<sup>3</sup> perforated shells.

Weight 22,900 kg

m	Undercarriage	3.0 m		4.5 m		6.0 m		7.5 m		9.0 m		10.5 m		m
10.5	Stabilizers raised			5.6	6.0*							4.6	5.0*	5.0
	4 pt. outriggers down			6.0*	6.0*							5.0*	5.0*	
9.0	Stabilizers raised					3.6	4.9					2.6	3.6	7.1
	4 pt. outriggers down					5.6*	5.6*					3.9*	3.9*	
7.5	Stabilizers raised					3.7	4.9	2.5	3.3			1.9	2.7	8.4
	4 pt. outriggers down					5.5*	5.5*	4.6*	4.6*			3.4*	3.4*	
6.0	Stabilizers raised			5.8	6.9*	3.6	4.8	2.4	3.3	1.7	2.4	1.6	2.3	9.2
	4 pt. outriggers down			6.9*	6.9*	5.6*	5.6*	4.6*	4.6*	3.8	3.9*	3.2*	3.2*	
4.5	Stabilizers raised			5.4	7.4	3.4	4.6	2.3	3.2	1.7	2.4	1.4	2.0	9.8
	4 pt. outriggers down			7.5*	7.5*	5.8*	5.8*	4.7*	4.7*	3.8	3.9*	3.1*	3.1*	
3.0	Stabilizers raised	7.6*	7.6*	4.8	6.8	3.1	4.4	2.2	3.1	1.6	2.3	1.3	1.9	10.1
	4 pt. outriggers down	7.6*	7.6*	8.3*	8.3*	6.1*	6.1*	4.8*	4.8*	3.7	3.8*	3.0*	3.0*	
1.5	Stabilizers raised			4.3	6.2	2.9	4.1	2.1	2.9	1.5	2.2	1.3	1.8	10.2
	4 pt. outriggers down			8.5*	8.5*	6.1*	6.1*	4.7*	4.7*	3.6*	3.6*	2.6*	2.6*	
0	Stabilizers raised	1.2*	1.2*	4.0	5.8	2.7	3.9	2.0	2.8	1.5	2.2	1.3	1.9	10.0
	4 pt. outriggers down	1.2*	1.2*	6.9*	6.9*	5.7*	5.7*	4.3*	4.3*	3.1*	3.1*	2.1*	2.1*	
-1.5	Stabilizers raised			3.9	5.7	2.6	3.8	1.9	2.8	1.5	2.2	1.5	2.1	9.1
	4 pt. outriggers down			6.1*	6.1*	4.7*	4.7*	3.5*	3.5*	2.3*	2.3*	2.2*	2.2*	

Height Can be slewed through 360° In longitudinal position of undercarriage Max. reach \* Limited by hydr. capacity

The lift capacities on the stick end without attachment are stated in metric tons (t) and are valid on a firm, level supporting surface with blocked oscillating axle. These capacities can be slewed through 360° with the undercarriage in the transverse position. Capacities in the longitudinal position of the undercarriage (±15°) are specified over the steering axle with the stabilizers raised and over the rigid axle with the stabilizers down. Indicated loads based on the ISO 10567 standard and do not exceed 75% of tipping or 87% of hydraulic capacity. The lift capacity of the unit is limited by its stability, the lifting capability of the hydraulic elements, or the maximum permissible lifting capacity of the load hook.

In accordance with the harmonised European Standard EN 474-5, hydraulic excavators used for lifting operations must be equipped with pipe fracture safety valves, an overload warning device, a load hook and a lift capacity chart.

# LH 22 M – Equipment GF9

Specially designed equipment for indoor application

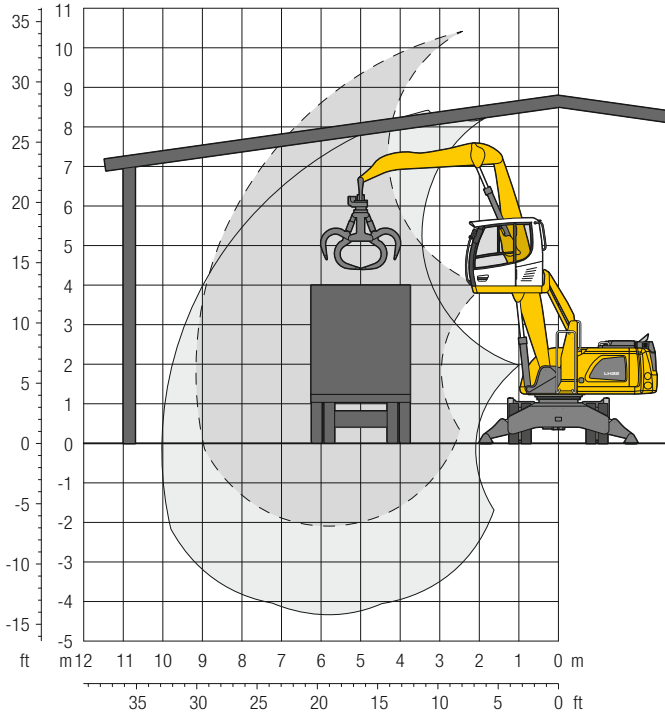

## Dimensions

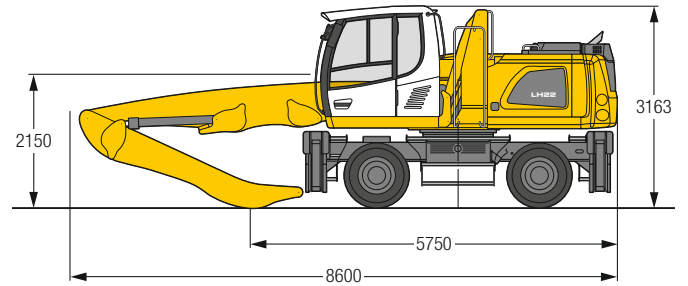

## Operating weight

The operating weight includes the basic machine with 4 point outriggers, hydr. cab elevation, 8 solid tyres plus intermediate rings, straight boom 5.50 m, flat angled stick 3.50 m and multi-tine grab GM 55B / 0.40 m<sup>3</sup> semi-closed tines.

Weight 22,400 kg

m	Undercarriage	3.0 m		4.5 m		6.0 m		7.5 m		9.0 m		10.5 m		m
9.0	Stabilizers raised			5.9	7.2*							4.2	5.1*	5.5
	4 pt. outriggers down			7.2*	7.2*							5.1*	5.1*	
7.5	Stabilizers raised			6.0	7.3*	3.8	5.1					2.9	3.8	7.1
	4 pt. outriggers down			7.3*	7.3*	6.1*	6.1*					4.3*	4.3*	
6.0	Stabilizers raised			5.9	7.5*	3.8	5.0	2.7	3.5			2.3	3.1	8.1
	4 pt. outriggers down			7.5*	7.5*	6.1*	6.1*	5.2*	5.2*			4.0*	4.0*	
4.5	Stabilizers raised	8.1*	8.1*	5.6	7.6	3.7	4.9	2.6	3.5			2.0	2.7	8.8
	4 pt. outriggers down	8.1*	8.1*	8.1*	8.1*	6.4*	6.4*	5.2*	5.2*			3.9*	3.9*	
3.0	Stabilizers raised	9.3	13.7	5.2	7.2	3.5	4.7	2.5	3.4	1.9	2.6	1.9	2.6	9.1
	4 pt. outriggers down	13.8*	13.8*	8.9*	8.9*	6.6*	6.6*	5.2*	5.2*	4.0*	4.0*	3.8*	3.8*	
1.5	Stabilizers raised	1.2*	1.2*	4.8	6.7	3.3	4.5	2.5	3.3	1.9	2.6	1.9	2.5	9.2
	4 pt. outriggers down	1.2*	1.2*	9.1*	9.1*	6.6*	6.6*	5.1*	5.1*	3.6*	3.6*	3.4*	3.4*	
0	Stabilizers raised	2.3*	2.3*	4.6	6.5	3.2	4.4	2.4	3.3			1.9	2.6	9.0
	4 pt. outriggers down	2.3*	2.3*	8.3*	8.3*	6.1*	6.1*	4.5*	4.5*			2.8*	2.8*	
-1.5	Stabilizers raised			4.6	6.4*	3.1	4.3	2.4	3.2			2.3	3.1	7.7
	4 pt. outriggers down			6.4*	6.4*	4.9*	4.9*	3.4*	3.4*			3.2*	3.2*	
-3.0	Stabilizers raised													
	4 pt. outriggers down													

Height Can be slewed through 360° In longitudinal position of undercarriage Max. reach \* Limited by hydr. capacity

The lift capacities on the stick end without attachment are stated in metric tons (t) and are valid on a firm, level supporting surface with blocked oscillating axle. These capacities can be slewed through 360° with the undercarriage in the transverse position. Capacities in the longitudinal position of the undercarriage (±15°) are specified over the steering axle with the stabilizers raised and over the rigid axle with the stabilizers down. Indicated loads based on the ISO 10567 standard and do not exceed 75% of tipping or 87% of hydraulic capacity. The lift capacity of the unit is limited by its stability, the lifting capability of the hydraulic elements, or the maximum permissible lifting capacity of the load hook.

In accordance with the harmonised European Standard EN 474-5, hydraulic excavators used for lifting operations must be equipped with pipe fracture safety valves, an overload warning device, a load hook and a lift capacity chart.

# LH 22 M – Equipment VK8

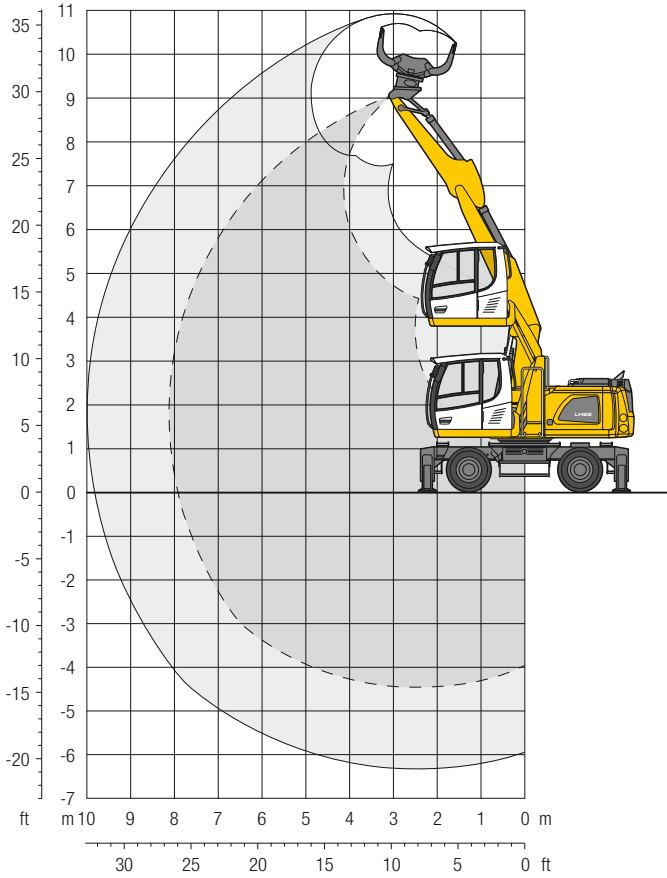

## Dimensions

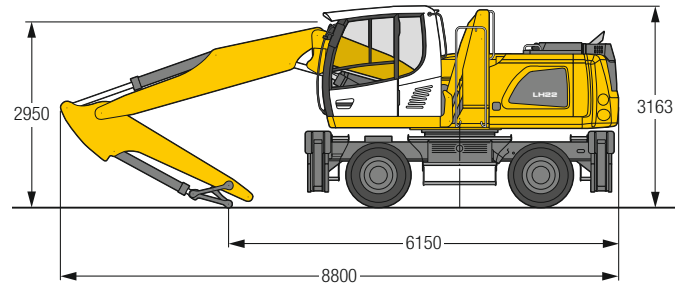

## Operating weight

The operating weight includes the basic machine with 4 point outriggers, hydr. cab elevation, 8 solid tyres plus intermediate rings, two-piece boom 5.25m, stick with tipping kinematics 2.65m and sorting grab SG 20B/ 0.50 m<sup>3</sup> perforated shells.

Weight 22,600 kg

m	Undercarriage	3.0m		4.5m		6.0m		7.5m		9.0m		10.5m		m
9.0	Stabilizers raised											4.2*	4.2*	3.2
	4 pt. outriggers down											4.2*	4.2*	
7.5	Stabilizers raised			5.1*	5.1*							2.9*	2.9*	5.6
	4 pt. outriggers down			5.1*	5.1*							2.9*	2.9*	
6.0	Stabilizers raised			5.1*	5.1*	3.9	4.6*					2.5*	2.5*	6.9
	4 pt. outriggers down			5.1*	5.1*	4.6*	4.6*					2.5*	2.5*	
4.5	Stabilizers raised	6.7*	6.7*	5.7	5.8*	3.8	4.8*	2.6	3.3*			2.4*	2.4*	7.6
	4 pt. outriggers down	6.7*	6.7*	5.8*	5.8*	4.8*	4.8*	3.3*	3.3*			2.4*	2.4*	
3.0	Stabilizers raised	9.4*	9.4*	5.5	6.8*	3.8	4.8	2.6	3.5			2.3	2.4*	8.0
	4 pt. outriggers down	9.4*	9.4*	6.8*	6.8*	5.2*	5.2*	4.3*	4.3*			2.4*	2.4*	
1.5	Stabilizers raised	9.5	10.4*	5.5	7.0	3.8	4.8	2.5	3.4			2.2	2.5*	8.1
	4 pt. outriggers down	10.4*	10.4*	7.6*	7.6*	5.5*	5.5*	4.3*	4.3*			2.5*	2.5*	
0	Stabilizers raised	9.6	11.9*	5.5	7.1	3.6	4.8	2.5	3.3			2.2	2.7*	7.9
	4 pt. outriggers down	11.9*	11.9*	7.7*	7.7*	5.6*	5.6*	4.3*	4.3*			2.7*	2.7*	
-1.5	Stabilizers raised	9.4	12.6*	5.3	7.3	3.4	4.6					2.4	3.2*	7.4
	4 pt. outriggers down	12.6*	12.6*	7.8*	7.8*	5.7*	5.7*					3.2*	3.2*	
-3.0	Stabilizers raised	9.3	13.0*	5.0	7.0	3.3	4.2*					3.0	3.0*	6.5
	4 pt. outriggers down	13.0*	13.0*	7.7*	7.7*	4.2*	4.2*					3.0*	3.0*	

Height Can be slewed through 360° In longitudinal position of undercarriage Max. reach \* Limited by hydr. capacity

The lift capacities on the stick end without attachment are stated in metric tons (t) and are valid on a firm, level supporting surface with blocked oscillating axle. These capacities can be slewed through 360° with the undercarriage in the transverse position. Capacities in the longitudinal position of the undercarriage (±15°) are specified over the steering axle with the stabilizers raised and over the rigid axle with the stabilizers down. The values apply with the optimum positioning of the two-piece boom. Indicated loads based on the ISO 10567 standard and do not exceed 75% of tipping or 87% of hydraulic capacity. The lift capacity of the unit is limited by its stability, the lifting capability of the hydraulic elements, or the maximum permissible lifting capacity of the load hook. In accordance with the harmonised European Standard EN 474-5, hydraulic excavators used for lifting operations must be equipped with pipe fracture safety valves, an overload warning device, a load hook and a lift capacity chart.

# LH 22 C – Equipment GA9

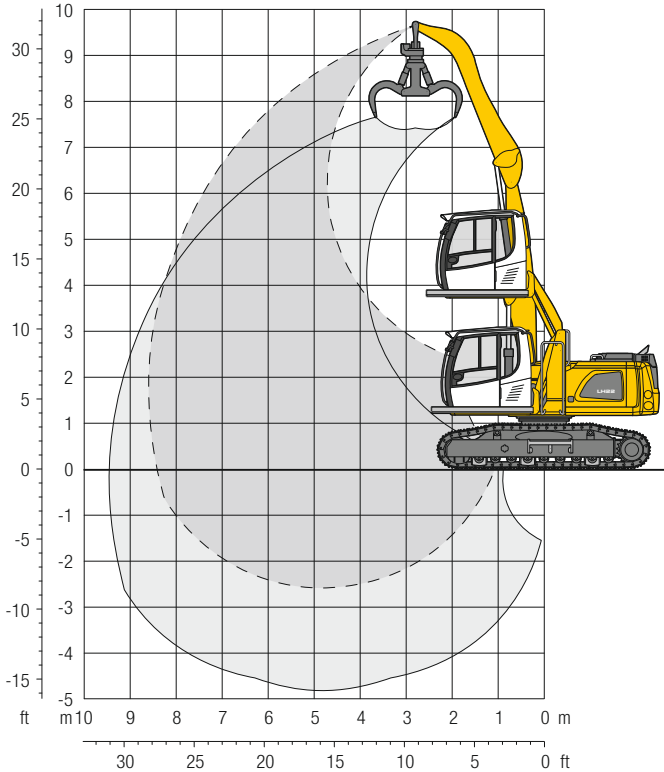

## Dimensions

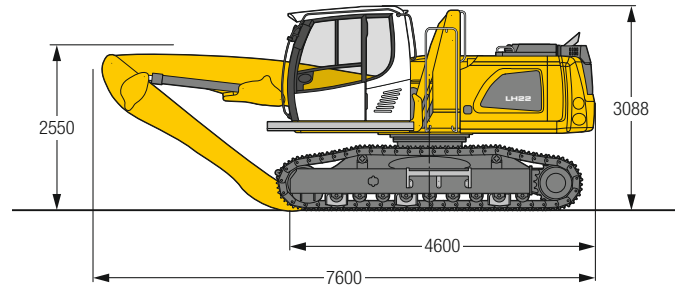

## Operating weight and ground pressure

The operating weight includes the basic machine with hydr. cab elevation, straight boom 4.50 m, angled stick 4.00 m and multi-tine grab GM 55B / 0.40 m<sup>2</sup> semi-closed tines.

Weight	22,700 kg
Pad width	600 mm
Ground pressure	on request

m	Undercarriage	3.0m		4.5m		6.0m		7.5m		9.0m		m		
		LC	LC	LC	LC	LC	LC	LC	LC	LC	LC			
10.5	LC													
9.0	LC													
7.5	LC					4.6*	4.6*					5.1*	5.1*	4.2
6.0	LC					5.4	6.1*					3.9*	3.9*	6.2
4.5	LC					5.4	6.1*					3.5*	3.5*	7.4
4.5	LC			7.3*	7.3*	5.3	6.3*	3.8	5.3*			3.3	3.3*	8.1
3.0	LC			8.0	8.2*	5.2	6.6*	3.7	5.4*			3.1	3.3*	8.5
1.5	LC	14.1*	14.1*	7.6	9.2*	5.0	6.8*	3.6	5.3*			3.0	3.4*	8.6
0	LC	8.1*	8.1*	7.2	9.3*	4.8	6.7*	3.6	4.9*			3.1	3.5*	8.4
-1.5	LC	7.6*	7.6*	7.1	8.1*	4.8	5.7*	3.6	3.6*			3.4*	3.4*	7.6

Height Can be slewed through 360° In longitudinal position of undercarriage Max. reach \* Limited by hydr. capacity

The lift capacities on the stick end without attachment are stated in metric tons (t) and can be slewed through 360° on a firm, level supporting surface. Capacities are valid for 600 mm wide triple grouser pads. Indicated loads based on the ISO 10567 standard and do not exceed 75% of tipping or 87% of hydraulic capacity. The lift capacity of the unit is limited by its stability, the lifting capability of the hydraulic elements, or the maximum permissible lifting capacity of the load hook.

In accordance with the harmonised European Standard EN 474-5, hydraulic excavators used for lifting operations must be equipped with pipe fracture safety valves, an overload warning device, a load hook and a lift capacity chart.

# LH 22 C – Equipment GA10

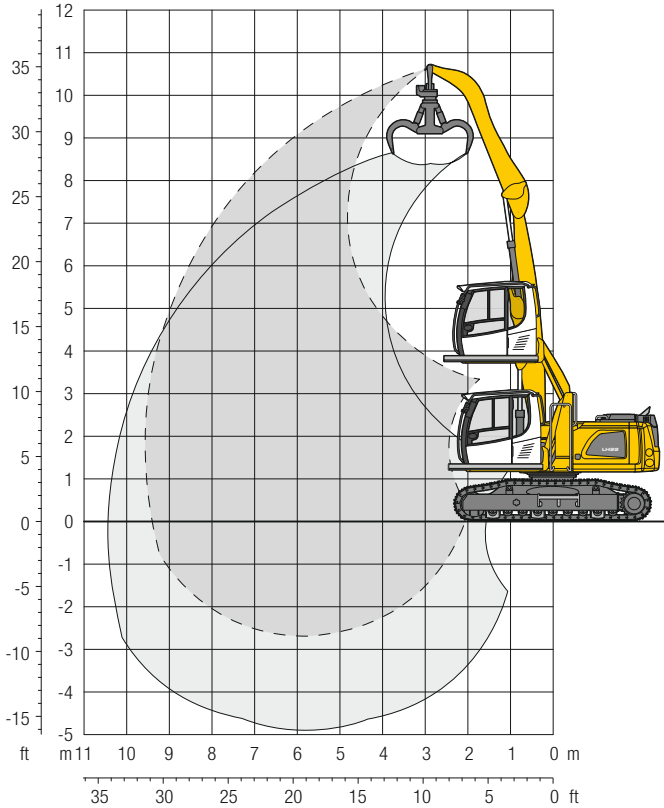

## Dimensions

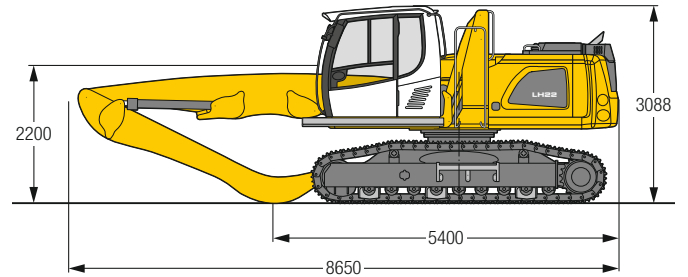

## Operating weight and ground pressure

The operating weight includes the basic machine with hydr. cab elevation, straight boom 5.50 m, angled stick 4.00 m and multi-tine grab GM 55B / 0.40 m<sup>3</sup> semi-closed tines.

Weight	23,000 kg
Pad width	600 mm
Ground pressure	on request

m	Undercarriage	3.0m		4.5m		6.0m		7.5m		9.0m		m
		LC	LC	LC	LC	LC	LC	LC	LC	LC	LC	
10.5	LC											3.2
9.0	LC			6.4*	6.4*	4.3*	4.3*					6.0
7.5	LC					5.4	5.9*	3.7	3.8*			7.5
6.0	LC					5.3	5.9*	3.8	5.1*			8.5
4.5	LC			7.6*	7.6*	5.2	6.1*	3.7	5.1*	2.8	3.9*	9.2
3.0	LC	12.7*	12.7*	7.6	8.5*	5.0	6.4*	3.6	5.2*	2.7	4.2*	9.5
1.5	LC	3.7*	3.7*	7.1	9.1*	4.8	6.6*	3.5	5.1*	2.7	3.9*	9.6
0	LC	3.0*	3.0*	6.8	8.7*	4.6	6.4*	3.4	4.8*	2.7	3.4*	9.4
-1.5	LC	4.1*	4.1*	6.7	7.3*	4.5	5.5*	3.3	4.0*	2.8*	2.8*	8.7

Height Can be slewed through 360° In longitudinal position of undercarriage Max. reach \* Limited by hydr. capacity

The lift capacities on the stick end without attachment are stated in metric tons (t) and can be slewed through 360° on a firm, level supporting surface. Capacities are valid for 600 mm wide triple grouser pads. Indicated loads based on the ISO 10567 standard and do not exceed 75% of tipping or 87% of hydraulic capacity. The lift capacity of the unit is limited by its stability, the lifting capability of the hydraulic elements, or the maximum permissible lifting capacity of the load hook.

In accordance with the harmonised European Standard EN 474-5, hydraulic excavators used for lifting operations must be equipped with pipe fracture safety valves, an overload warning device, a load hook and a lift capacity chart.

# LH 22 C – Equipment GK8

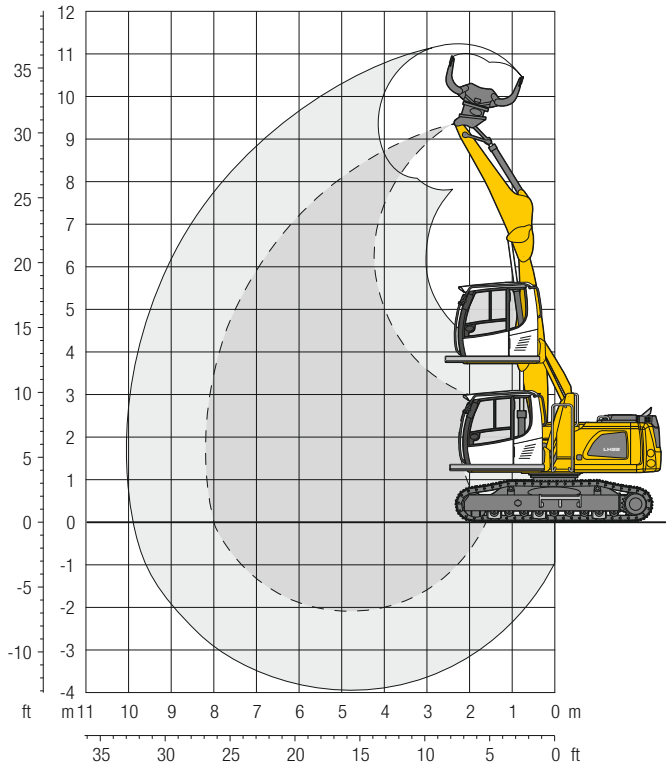

## Dimensions

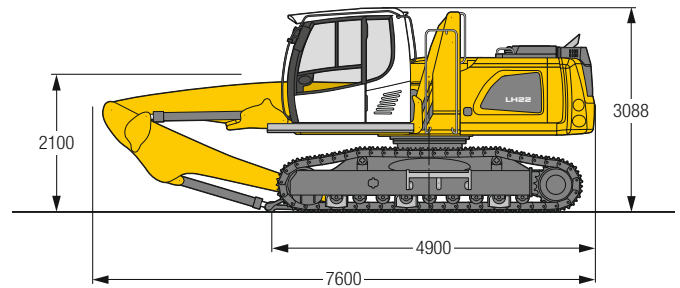

## Operating weight and ground pressure

The operating weight includes the basic machine with hydr. cab elevation, straight boom 4.50 m, stick with tipping kinematics 3.50 m and sorting grab SG 20B / 0.50 m<sup>3</sup> perforated shells.

Weight	22,900 kg
Pad width	600 mm
Ground pressure	on request

m	Undercarriage	3.0m		4.5m		6.0m		7.5m		9.0m		m		
9.0	LC	7.7*	7.7*									7.0*	7.0*	3.3
7.5	LC			7.1*	7.1*							4.6*	4.6*	5.6
6.0	LC			7.3*	7.3*	5.1	6.2*					4.0*	4.0*	6.9
4.5	LC			7.6*	7.6*	5.0	6.3*	3.5	4.7*			3.4	3.7*	7.7
3.0	LC	9.2*	9.2*	7.6	8.4*	4.9	6.5*	3.5	5.1*			3.1	3.7*	8.1
1.5	LC	13.9	14.4*	7.2	9.1*	4.7	6.6*	3.4	4.9*			3.0	3.8*	8.2
0	LC	5.9*	5.9*	6.9	8.8*	4.6	6.2*	3.4	4.2*			3.1	3.1*	8.0
-1.5	LC	7.2*	7.2*	6.8	7.1*	4.5	4.9*					3.6*	3.6*	6.8

Height Can be slewed through 360° In longitudinal position of undercarriage Max. reach \* Limited by hydr. capacity

The lift capacities on the stick end without attachment are stated in metric tons (t) and can be slewed through 360° on a firm, level supporting surface. Capacities are valid for 600 mm wide triple grouser pads. Indicated loads based on the ISO 10567 standard and do not exceed 75% of tipping or 87% of hydraulic capacity. The lift capacity of the unit is limited by its stability, the lifting capability of the hydraulic elements, or the maximum permissible lifting capacity of the load hook.

In accordance with the harmonised European Standard EN 474-5, hydraulic excavators used for lifting operations must be equipped with pipe fracture safety valves, an overload warning device, a load hook and a lift capacity chart.



# LH 22 C – Equipment GK9

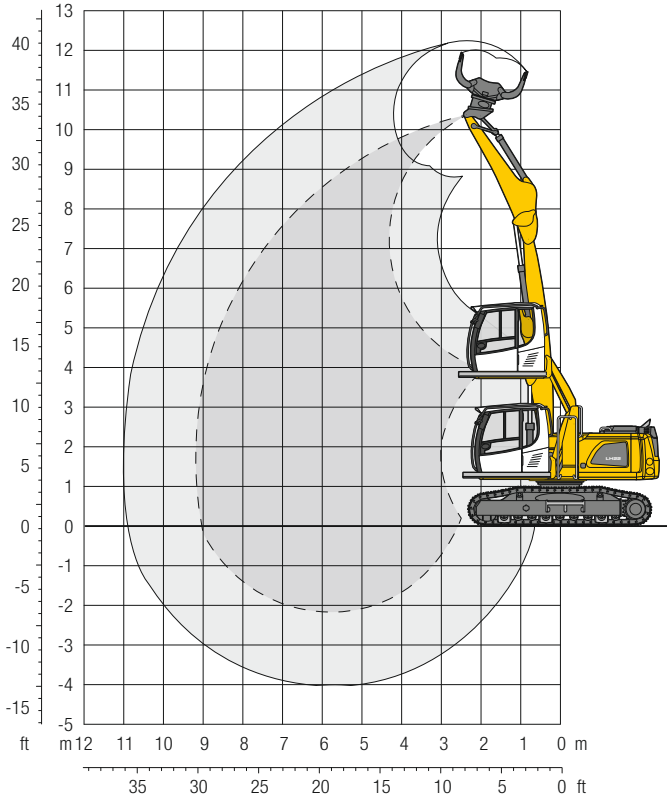

## Dimensions

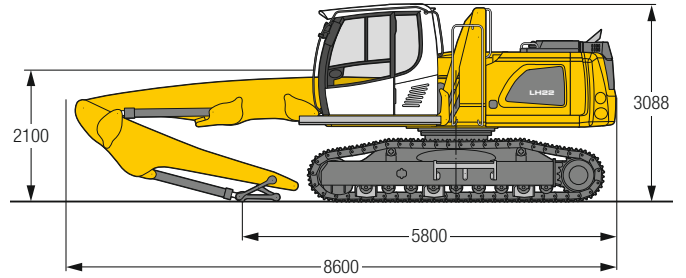

## Operating weight and ground pressure

The operating weight includes the basic machine with hydr. cab elevation, straight boom 5.50 m, stick with tipping kinematics 3.50 m and sorting grab SG 20B / 0.50 m<sup>3</sup> perforated shells.

Weight	23,200 kg
Pad width	600 mm
Ground pressure	on request

m	Undercarriage	3.0m		4.5m		6.0m		7.5m		9.0m		m		
		Can be slewed through 360°	In longitudinal position of undercarriage	Can be slewed through 360°	In longitudinal position of undercarriage	Can be slewed through 360°	In longitudinal position of undercarriage	Can be slewed through 360°	In longitudinal position of undercarriage	Can be slewed through 360°	In longitudinal position of undercarriage			
9.0	LC			6.9*	6.9*							5.2*	5.2*	5.3
7.5	LC			7.1*	7.1*	5.1	5.9*					3.8	4.2*	7.0
6.0	LC			7.2*	7.2*	5.0	5.9*	3.5	4.9*			3.0	3.8*	8.1
4.5	LC			7.8	7.8*	4.9	6.1*	3.4	4.9*			2.7	3.7*	8.7
3.0	LC	13.3*	13.3*	7.3	8.5*	4.7	6.3*	3.3	4.9*	2.5	3.7*	2.5	3.6*	9.1
1.5	LC	0.9*	0.9*	6.8	8.8*	4.5	6.3*	3.2	4.8*	2.5	3.4*	2.4	3.1*	9.2
0	LC	1.8*	1.8*	6.5	8.0*	4.3	5.9*	3.2	4.3*	2.5	2.6*	2.5	2.5*	9.0
-1.5	LC			6.2*	6.2*	4.2	4.7*	3.1	3.3*			2.8*	2.8*	7.9

Height Can be slewed through 360° In longitudinal position of undercarriage Max. reach \* Limited by hydr. capacity

The lift capacities on the stick end without attachment are stated in metric tons (t) and can be slewed through 360° on a firm, level supporting surface. Capacities are valid for 600 mm wide triple grouser pads. Indicated loads based on the ISO 10567 standard and do not exceed 75% of tipping or 87% of hydraulic capacity. The lift capacity of the unit is limited by its stability, the lifting capability of the hydraulic elements, or the maximum permissible lifting capacity of the load hook.

In accordance with the harmonised European Standard EN 474-5, hydraulic excavators used for lifting operations must be equipped with pipe fracture safety valves, an overload warning device, a load hook and a lift capacity chart.

# LH 22 C – Equipment GF8

Specially designed equipment for indoor application

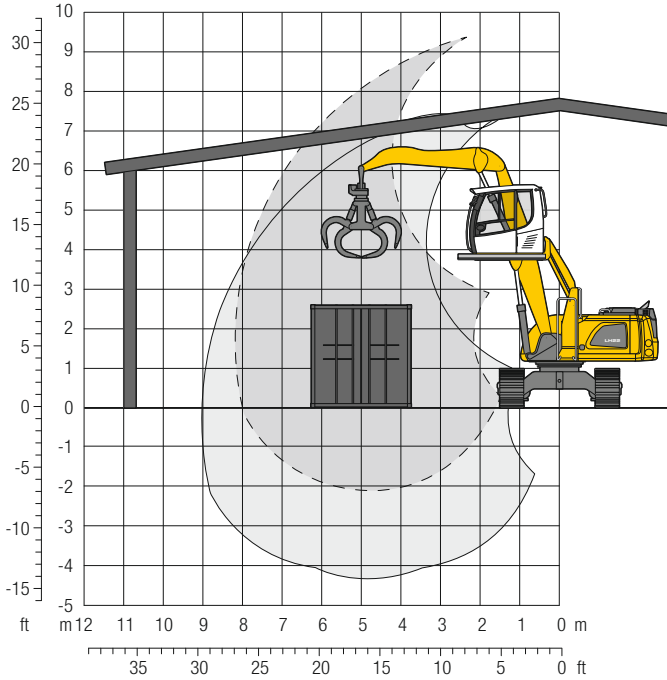

## Dimensions

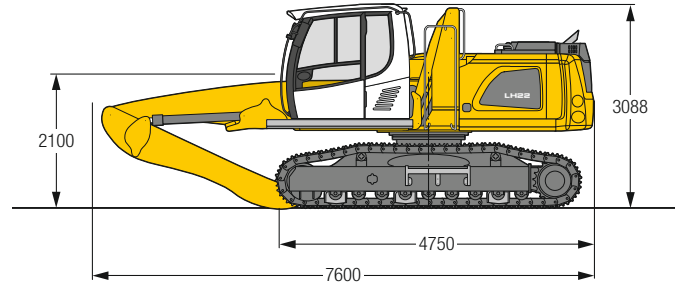

## Operating weight and ground pressure

The operating weight includes the basic machine with hydr. cab elevation, straight boom 4.50 m, flat angled stick 3.50 m and multi-tine grab GM 55B / 0.40 m<sup>3</sup> semi-closed tines.

Weight	22,600 kg
Pad width	600 mm
Ground pressure	on request

m	Undercarriage	3.0m		4.5m		6.0m		7.5m		9.0m		m
9.0	LC	7.7*	7.7*							7.1*	7.1*	3.2
7.5	LC			7.3*	7.3*					4.8*	4.8*	5.6
6.0	LC			7.5*	7.5*	5.3	6.5*			4.1*	4.1*	6.9
4.5	LC			7.9*	7.9*	5.2	6.5*	3.7	4.8*	3.6	3.9*	7.7
3.0	LC	9.8*	9.8*	7.9	8.7*	5.1	6.8*	3.7	5.4*	3.3	3.8*	8.1
1.5	LC	14.3	14.8*	7.5	9.4*	5.0	6.9*	3.6	5.2*	3.2	4.0*	8.2
0	LC	6.2*	6.2*	7.2	9.2*	4.9	6.5*	3.6	4.5*	3.3	3.5*	8.0
-1.5	LC	7.4*	7.4*	7.1	7.5*	4.8	5.2*			3.9*	3.9*	6.8
-3.0	LC											

Height Can be slewed through 360° In longitudinal position of undercarriage Max. reach \* Limited by hydr. capacity

The lift capacities on the stick end without attachment are stated in metric tons (t) and can be slewed through 360° on a firm, level supporting surface. Capacities are valid for 600 mm wide triple grouser pads. Indicated loads based on the ISO 10567 standard and do not exceed 75% of tipping or 87% of hydraulic capacity. The lift capacity of the unit is limited by its stability, the lifting capability of the hydraulic elements, or the maximum permissible lifting capacity of the load hook.

In accordance with the harmonised European Standard EN 474-5, hydraulic excavators used for lifting operations must be equipped with pipe fracture safety valves, an overload warning device, a load hook and a lift capacity chart.

# LH 22 C – Equipment VK8

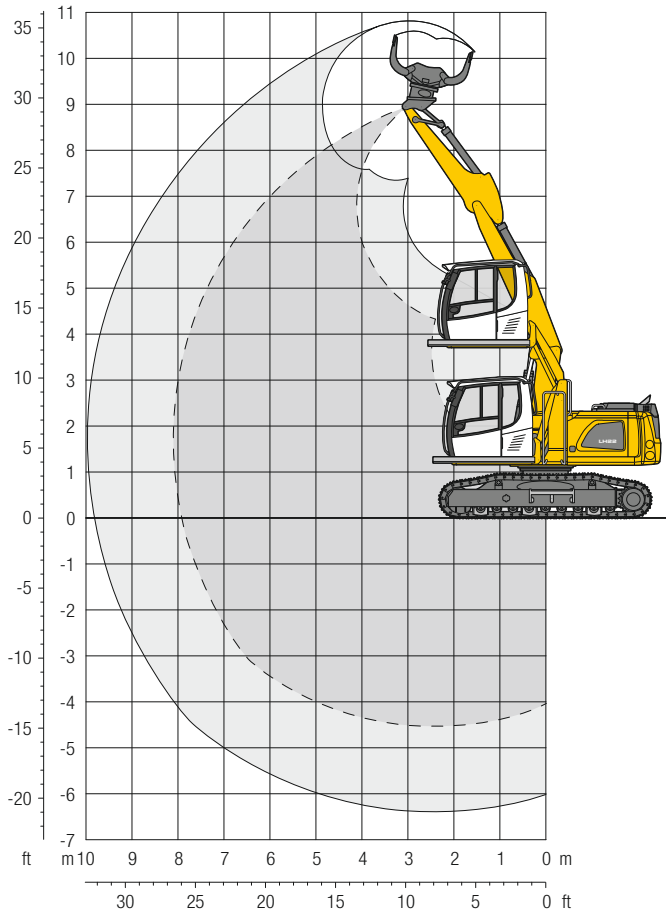

## Dimensions

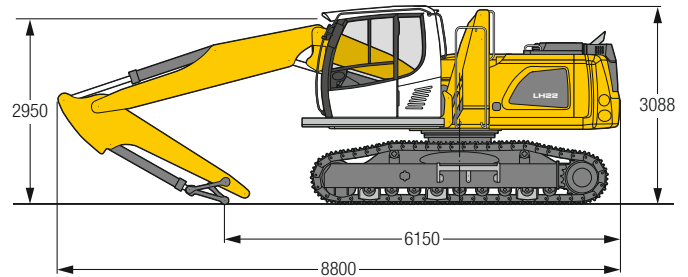

## Operating weight and ground pressure

The operating weight includes the basic machine with hydr. cab elevation, two-piece boom 5.25 m, stick with tipping kinematics 2.65 m and sorting grab SG 20B / 0.50 m<sup>3</sup> perforated shells.

Weight	23,100 kg
Pad width	600 mm
Ground pressure	on request

m	Undercarriage	3.0m		4.5m		6.0m		7.5m		9.0m		m
		LC	LC	LC	LC	LC	LC	LC	LC	LC	LC	
7.5	LC			5.1*	5.1*							5.5
6.0	LC			5.1*	5.1*	4.6*	4.6*					6.8
4.5	LC	6.3*	6.3*	5.7*	5.7*	4.7*	4.7*	3.1*	3.1*			7.6
3.0	LC	9.3*	9.3*	6.7*	6.7*	5.0	5.1*	3.6	4.3*			8.0
1.5	LC	10.4*	10.4*	7.3	7.6*	5.0	5.5*	3.6	4.3*			8.1
0	LC	11.8*	11.8*	7.3	7.7*	5.0	5.6*	3.5	4.3*			7.9
-1.5	LC	12.6*	12.6*	7.5	7.8*	4.8	5.7*					7.4
-3.0	LC	13.0*	13.0*	7.3	7.8*	4.4*	4.4*					6.5
-4.5	LC	8.1*	8.1*									3.3

Height Can be slewed through 360° In longitudinal position of undercarriage Max. reach \* Limited by hydr. capacity

The lift capacities on the stick end without attachment are stated in metric tons (t) and can be slewed through 360° on a firm, level supporting surface. Capacities are valid for 600 mm wide triple grouser pads. The values apply with the optimum positioning of the two-piece boom. Indicated loads based on the ISO 10567 standard and do not exceed 75% of tipping or 87% of hydraulic capacity. The lift capacity of the unit is limited by its stability, the lifting capability of the hydraulic elements, or the maximum permissible lifting capacity of the load hook. In accordance with the harmonised European Standard EN 474-5, hydraulic excavators used for lifting operations must be equipped with pipe fracture safety valves, an overload warning device, a load hook and a lift capacity chart.

# Machine stabilities sorting grabs

## LH 22 M – Max. material weight in t/m<sup>3</sup>

Grab	Shell type	Capacity m <sup>3</sup>	Mounting for direct mounting						Mounting for quick coupler SWA 48					
			4 pt. outriggers down			Blade + 2 pt. outriggers down			4 pt. outriggers down			Blade + 2 pt. outriggers down		
			GK9	GK10	VK8	GK9	GK10	VK8	GK9	GK10	VK8	GK9	GK10	VK8
SG 20B	perforated	0.40	3.2	2.0	1.5	2.2	1.0	1.5	2.5	1.3	0.8	1.5	0.3	0.8
SG 20B	perforated	0.50	2.5	1.5	1.1	1.7	0.7	1.1	1.9	0.9	0.5	1.1	-	0.5
SG 20B	perforated	0.60	2.0	1.1	0.8	1.3	0.5	0.8	1.5	0.7	0.3	0.8	-	0.3
SG 20B	perforated	0.70	1.6	0.9	0.6	1.0	0.3	0.6	1.2	0.5	-	0.7	-	-
SG 20B	closed	0.40	3.2	1.9	1.4	2.2	0.9	1.4	2.5	1.2	0.7	1.5	-	0.7
SG 20B	closed	0.50	2.4	1.4	1.0	1.6	0.6	1.0	1.9	0.9	0.5	1.1	-	0.5
SG 20B	closed	0.60	2.0	1.1	0.8	1.3	0.5	0.8	1.5	0.7	0.3	0.8	-	0.3
SG 20B	closed	0.70	1.6	0.9	0.6	1.0	0.3	0.6	1.2	0.5	-	0.6	-	-

- = Load values at maximum outreach insufficient

## LH 22 C – Max. material weight in t/m<sup>3</sup>

Grab	Shell type	Capacity m <sup>3</sup>	Mounting for direct mounting LC undercarriage			Mounting for quick coupler SWA 48 LC undercarriage		
			GK8	GK9	VK8	GK8	GK9	VK8
SG 20B	perforated	0.40	2.7	1.2	1.5	2.0	0.5	0.8
SG 20B	perforated	0.50	2.1	0.9	1.1	1.5	0.3	0.5
SG 20B	perforated	0.60	1.6	0.6	0.8	1.2	-	0.3
SG 20B	perforated	0.70	1.3	0.5	0.6	0.9	-	-
SG 20B	closed	0.40	2.7	1.2	1.4	2.0	0.5	0.7
SG 20B	closed	0.50	2.0	0.8	1.0	1.5	0.3	0.5
SG 20B	closed	0.60	1.6	0.6	0.8	1.2	-	0.3
SG 20B	closed	0.70	1.3	0.5	0.6	0.9	-	-

- = Load values at maximum outreach insufficient

# Attachments

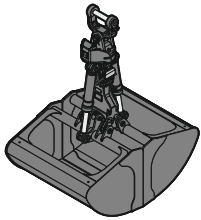

## Grab for loose material

Shells for loose material with cutting edge (without teeth)

Grab model GZ 26					
Width of shells	mm	1,000	1,250	1,500	1,750
Capacity	m <sup>3</sup>	1.20	1.50	1.80	2.10
Weight	kg	1,130	1,205	1,295	1,405



## Multi-tine grab

open

semi-closed

closed, heart-shaped

Grab model GMM 35-4 (4 tines)					
Capacity	m <sup>3</sup>	0.60		0.60	0.60
Weight	kg	1,260		1,325	1,420
Grab model GM 55B (5 tines)					
Capacity	m <sup>3</sup>	0.40		0.40	0.40
Weight	kg	995		1,120	1,375
Grab model GMM 35-5 (5 tines)					
Capacity	m <sup>3</sup>	0.60		0.60	0.60
Weight	kg	1,450		1,515	1,560

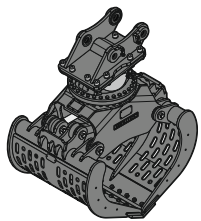

## Sorting grab

perforated

ribbed

closed

Grab model SG 20B													
Width of shells	mm	800	1,000	1,200	1,400					800	1,000	1,200	1,400
Capacity	m <sup>3</sup>	0.40	0.50	0.60	0.70					0.40	0.50	0.60	0.70
Max. closing force	kN	40	40	40	40					40	40	40	40
Weight incl. quick coupler mounting SWA 48	kg	950	995	1,040	1,085					965	1,010	1,050	1,095
Grab model SG 25B													
Width of shells	mm	800	1,000	1,200	1,400	800	1,000	1,200	800	1,000	1,200	1,400	
Capacity	m <sup>3</sup>	0.55	0.75	0.90	1.10	0.50	0.65	0.80	0.55	0.75	0.90	1.10	
Max. closing force	kN	60	60	60	60	60	60	60	60	60	60	60	
Weight incl. quick coupler mounting SWA 48	kg	1,240	1,305	1,370	1,435	1,285	1,370	1,455	1,260	1,330	1,400	1,470	

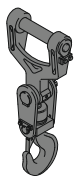

## Load hook

Max. load	t	12.5
Height with suspension	mm	930
Weight	kg	135

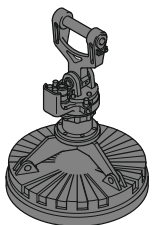

## Magnet devices / lifting magnets

Generator	kW	10
Electromagnet with suspension		
Power	kW	8.8
Diameter of magnet	mm	1,250
Weight	kg	1,415*

\* only magnet plate

# Equipment

## Undercarriage

	22 M	22 C
Track pads, variants		+
Individual control outriggers	+	
Shuttle axle lock, automatic	●	
Outrigger monitoring system	+	
Dozer blade	+	
Tyres, variants	+	
Protection for travel drive	+	
Protection for piston rods, outriggers	+	
Two lockable storage compartments	●	
Undercarriage, variants	+	

## Uppercarriage

	22 M	22 C
Uppercarriage right side light, 1 piece, LED	●	●
Uppercarriage rear light, 2 pieces, LED	+	+
Refuelling system with filling pump	+	+
Generator	+	+
Main battery switch for electrical system	●	●
Recycling package	+	+
Amber beacon, at uppercarriage, LED double flash	+	+
Protection for headlights	+	+
Protection for rear lights	+	+
Tool equipment, extended	+	+

## Hydraulic system

	22 M	22 C
Electronic pump regulation	●	●
Liebherr hydraulic oil from -20 °C to +40 °C	●	●
Liebherr hydraulic oil, biologically degradable	+	+
Magnetic rod in hydraulic tank	●	●
Bypass filter	+	+
Preheating hydraulic oil	+	+

## Engine

	22 M	22 C
Fuel anti-theft device	+	+
Automatic engine shut-down (time adjustable)	+	+
Preheating fuel	+	+
Preheating coolant*	+	+
Preheating engine oil*	+	+

## Cooling system

	22 M	22 C
Radiator, large-mesh, for dust-intensive operation	●	●
Reversible fan drive, fully automatic	+	+
Protective grid (close-mesh) in front of cooler intake, extendible	●	●



## Cab

	22 M	22 C
Stabilizer, control lever, left console	+	
Stabilizer, proportional control on left joystick	●	
Cab lights front, halogen	+	+
Cab lights front, halogen (under rain cover)	●	●
Cab lights front, LED	+	+
Cab lights front, LED (under rain cover)	+	+
Armrest adjustable	●	●
Slewing gear brake Comfort, button on the left or right joystick	+	
Operator's seat Comfort	●	●
Operator's seat Premium	+	+
Driving alarm (acoustic signal is emitted during travel, can be switched ON / OFF)	+	+
Fire extinguisher	+	+
Footrest	+	+
Horn, button on left joystick	●	●
Joystick steering (max. 12 km/h)	●	
Joystick and wheel steering (slim version)	+	
Cab elevation, hydraulic (LHC)	●	●
Cab elevation, hydraulic with tilt function (LHC)	+	+
Cab elevation, hydraulic with connecting piece 1,000 mm (LHC)	+	+
Cab elevation, rigid (LFC)	+	+
Automatic air conditioning	●	●
Wheel steering (slim version)	+	
LiDAT, vehicle fleet management	●	●
Proportional control	●	●
Radio Comfort, control via display with handsfree set	+	+
Preparation for radio installation	●	●
Back-up alarm (acoustic signal is emitted traveling backward, can not be switched off)	+	
Amber beacon, on cab, LED double flash	+	+
Windows made from impact-resistant laminated safety glass	+	+
Windscreen wiper, roof	+	+
Windshield wiper, entire windscreen	●	●
FOPS top guard	+	+
FGPS front guard, tiltable	+	+
Sun visor	+	+
Left control console, folding	●	●



## Equipment

	22 M	22 C
Boom lights, 2 pieces, halogen	●	●
Boom lights, 2 pieces, LED	+	+
Stick lights, 2 pieces, halogen	●	●
Stick lights, 2 pieces, LED	+	+
Filter system for attachment	+	+
Height limitation and stick shutoff, electronically	+	+
Boom cylinder cushioning	+	+
Stick camera (with separate monitor), bottom side, with protection	+	+
Liebherr multi coupling system	+	+
Liebherr quick coupler, hydraulic	+	+
Pipe fracture safety valves hoist cylinders	●	●
Pipe fracture safety valves stick cylinders	●	●
Quick coupling system Solidlink	+	+
Protection for piston rods, hoist cylinder	+	+
Protection for piston rods, stick cylinder	+	+
Overload warning device	+	+



## Complete machine

	22 M	22 C
<b>Lubrication</b>		
Lubrication undercarriage, manually - decentralised (grease points)	●	
Lubrication undercarriage, manually - centralised (one grease point)	+	
Central lubrication system for uppercarriage and equipment, automatically	●	●
Central lubrication system for undercarriage, automatically	+	
Centralised lubrication extended for attachment	+	+
<b>Special coating</b>		
Special coating, variants	+	+
<b>Monitoring</b>		
Rear view monitoring with camera	●	●
Side view monitoring with camera	●	●

● = Standard, + = Option

\* = country-dependent

Options and / or special equipment, supplied by vendors other than Liebherr, are only to be installed with the knowledge and approval of Liebherr in order to retain warranty.

# The Liebherr Group

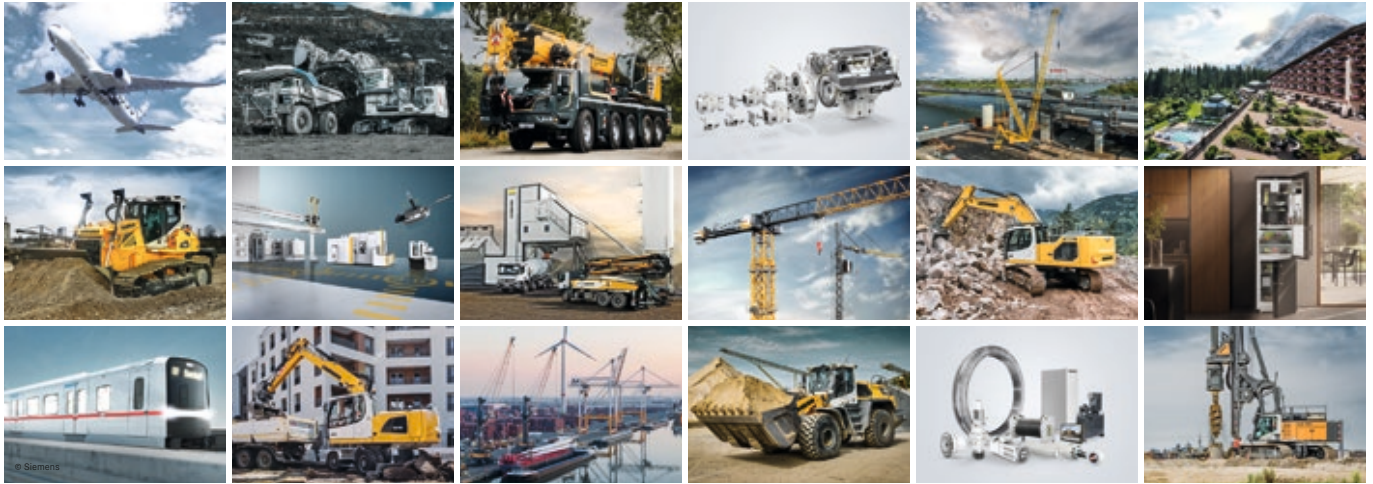

## Global and independent: more than 70 years of success

Liebherr was founded in 1949 when, with the development of the world's first mobile tower crane, Hans Liebherr laid the foundations for a family-run company which now has more than 50,000 employees and comprises over 150 companies across every continent. The holding company of the Group is Liebherr-International AG in Bulle, Switzerland, whose shareholders are exclusively members of the Liebherr family.

## Technology leadership and pioneering spirit

Liebherr is a pioneer and its forward-looking approach has seen it make important contributions to technology history over a wide variety of industries. Employees throughout the world continue to share the courage of the company founder, sharing a passion to produce innovative products and a determination to provide world-leading equipment and machinery.

## Diversified product programme

Liebherr is one of the world's biggest construction machine manufacturers and provides high-quality, user-oriented products and services. Its product programme includes earthmoving machinery, material handling technology, deep foundation machines, mining, mobile and crawler cranes, tower cranes, concrete technology, maritime cranes, aerospace and transportation systems, gear technology and automation systems, refrigerators and freezers, components and hotels.

## Customised solutions and maximum customer value

Liebherr solutions are characterised by precision, implementation and longevity. The company is committed to technological excellence and to providing customers with solutions that match their needs exactly. For Liebherr, customer focus does not end with delivery of a product but continues through a comprehensive range of back-up and support services.

[www.liebherr.com](http://www.liebherr.com)

## Liebherr-Hydraulikbagger GmbH

Liebherrstraße 12 • 88457 Kirchdorf/Iller, Germany • Phone +49 7354 80-0 • Fax +49 7354 80-72 94  
info.lhb@liebherr.com • [www.liebherr.com](http://www.liebherr.com) • [www.facebook.com/LiebherrConstruction](https://www.facebook.com/LiebherrConstruction)