

Datos Técnicos

Grúa de celosía sobre cadenas

LR 1100

Litronic®

- Elevación

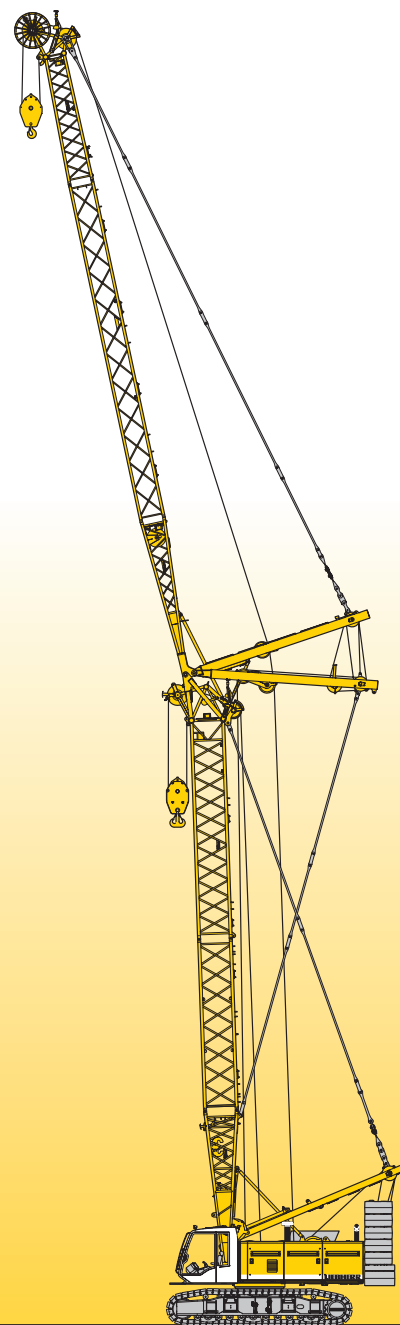

LIEBHERR

Dimensiones

Máquina base con chasis inferior

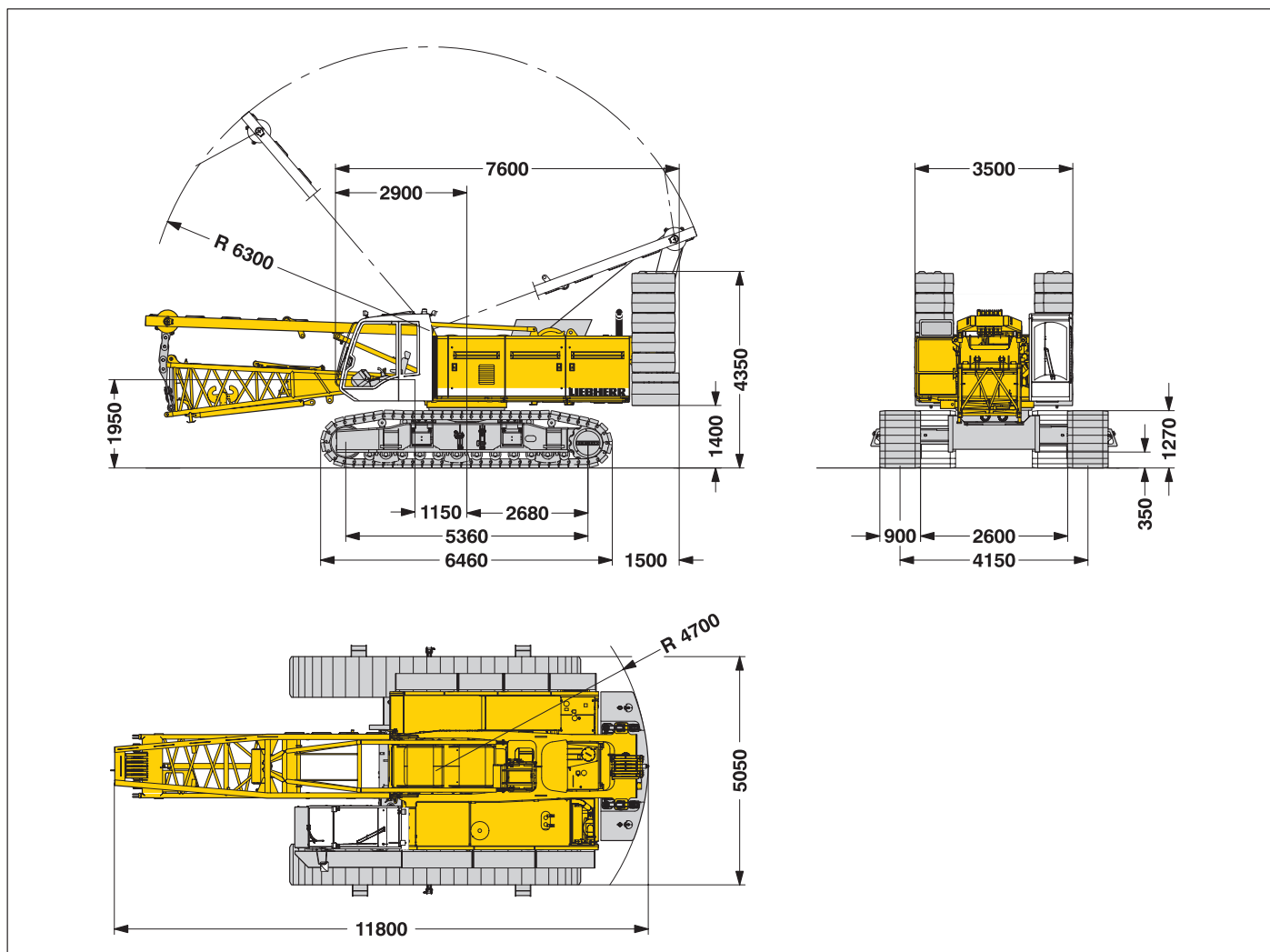

Peso operacional

El peso operacional incluye la máquina base con cadenas, 2 cabrestantes principales de 120 kN y una pluma principal de 14 m, que se compone de un caballete, pie de pluma (5.5m), cabeza de pluma (8.5m), contrapeso base (32.3 t), contrapeso central 15 t, y un gancho de 100 t de capacidad.

Peso total _____ aprox. 109.8 t

Presión sobre el suelo

Presión sobre el suelo _____ 1.14 kg/cm²

Equipo de trabajo

Pluma principal (Nº 1311.xx) longitud máxima _____ 68 m
De largo alcance (Nº 1311.xx y 1008.xx) _____ 83 m
Plumín abatible (Nº 1008.xx) longitud máxima _____ 62 m
Combinación máxima con pluma de 38 m y plumín abatible de _____ 62 m
Plumín fijo (Nº 0806.xx) _____ 11 m – 32 m
Plumín auxiliar con capacidad de 24 t (opcional 36 t)

Observaciones

1. Las mencionadas capacidades de carga son válidas para trabajos de elevación (corresponden según clasificación de grúas F.E.M. 1001, grupo de grúas A1).
2. La grúa debe estar situada sobre un terreno horizontal y firme.
3. Los pesos de los implementos de elevación (tales como cables de elevación, ganchos, cuñeros etc) se tienen que deducir de los valores de carga.
4. Equipos adicionales montados en la pluma (tales como pasarelas), plumín auxiliar se tienen que deducir de los valores de carga.
5. Para conocer las velocidades máximas de viento durante el trabajo con la grúa, consultar la introducción de la tabla de cargas.
6. El radio de trabajo se mide desde el centro de la corona.
7. Las capacidades de carga están indicadas en toneladas y son válidas para 360 grados de giro.
8. El cálculo de estabilidad bajo la carga está basado en DIN 15019 / parte 2 / tabla 1/ ISO 4305 Tabla 1 + 2, valor vuelco 4°.
9. Las estructuras están calculadas según F.E.M 1.001 – 1998 (prEN 13001 / T2 / 1997)

Dimensiones y pesos de transporte

Máquina base y pluma (Nº 1311.xx)

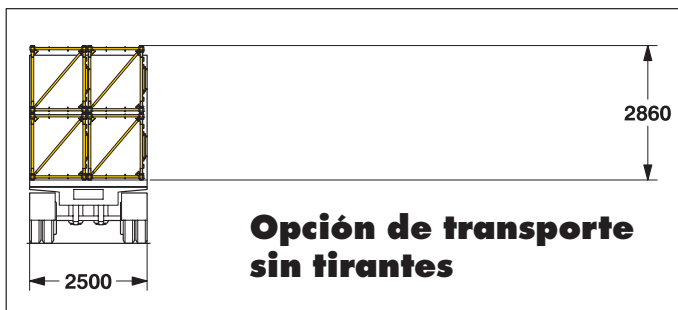
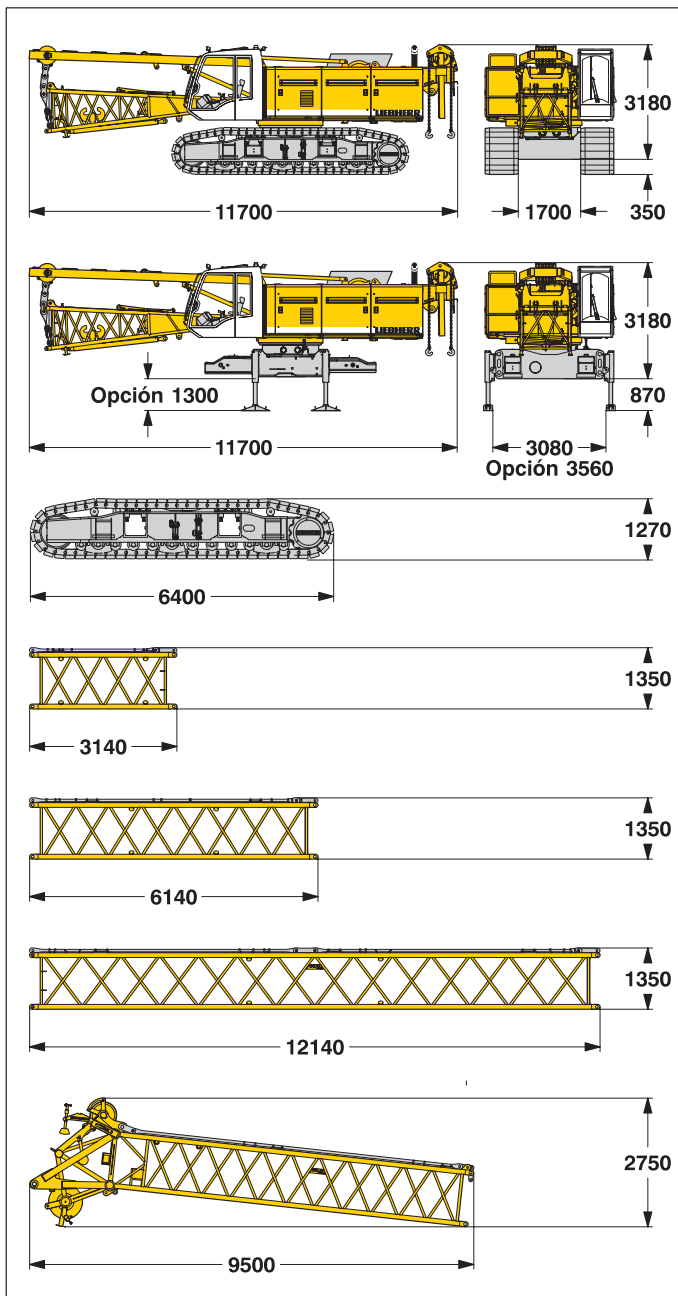

Opción de transporte sin tirantes

*) Incluye tirantes

Máquina base

Con chasis inferior, pie de pluma (Nº 1311.xx), caballete, 2 cabestrantes de 120 kN sin cables de carga, sin contrapeso base

Ancho	mm	3500
Peso	kg	57150

Máquina base

Con pie de pluma (Nº 1311.xx), caballete, 2 cabestrantes de 120 kN sin cables de carga, sin contrapeso base y cadenas.

Ancho	mm	3500
Peso	kg	36750

Cadenas

2x

Tejas	mm	900
Ancho	mm	915
Peso	kg	10200

Tramo de pluma (Nº 1311.xx)

3 m

Ancho	mm	1400
Peso*	kg	510

Tramo de pluma (Nº 1311.xx)

6 m

Ancho	mm	1400
Peso*	kg	880

Tramo de pluma (Nº 1311.xx)

12 m

Ancho	mm	1400
Peso*	kg	1540

Cabeza de pluma (Nº 1311.xx)

Ancho	mm	1750
Peso*	kg	2350

Opción de transporte de pluma

Longitud	mm	12140
Peso*	kg	6160

Dimensiones y pesos de transporte

Plumín abatible (N° 1008.xx)

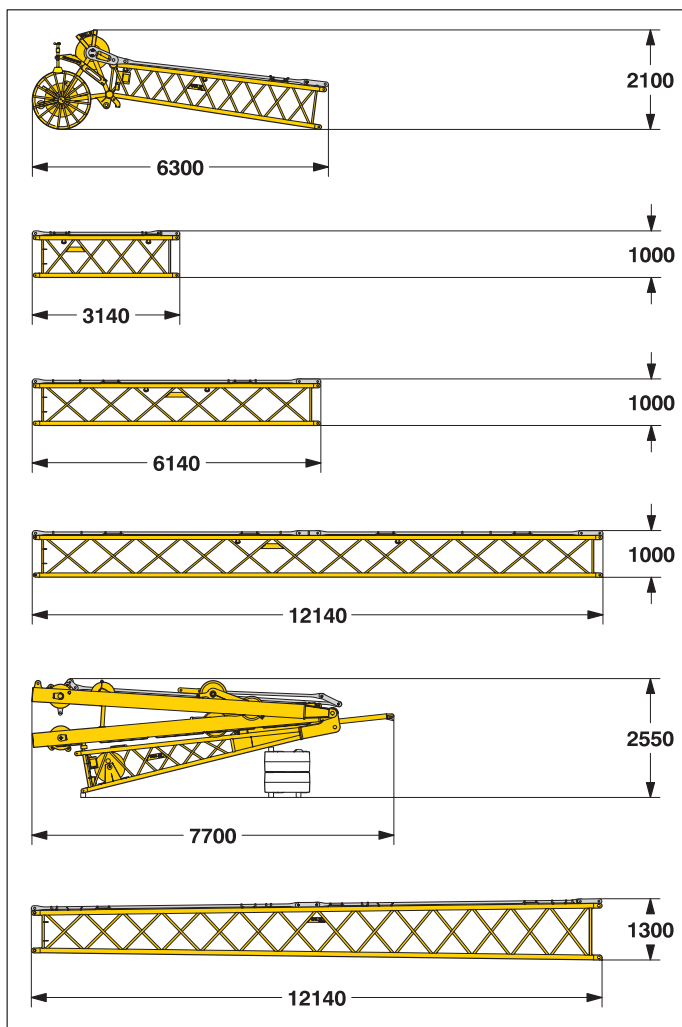

Cabeza de plumín abatible (N° 1008.xx)

Ancho	mm	1300
Peso*	kg	970

Tramo plumín abatible (N° 1008.xx) 3 m

Ancho	mm	1200
Peso*	kg	296

Tramo plumín abatible (N° 1008.xx) 6 m

Ancho	mm	1200
Peso*	kg	455

Tramo plumín abatible (N° 1008.xx) 12 m

Ancho	mm	1200
Peso*	kg	860

Pie de plumín abatible con caballete (N° 1008.xx)

Ancho	mm	1600
Peso*	kg	3900

Tramo de pluma cónica (N° 1311/1008.xx) 12 m

Ancho	mm	1400
Peso*	kg	1150

Plumín fijo (N° 0806.xx)

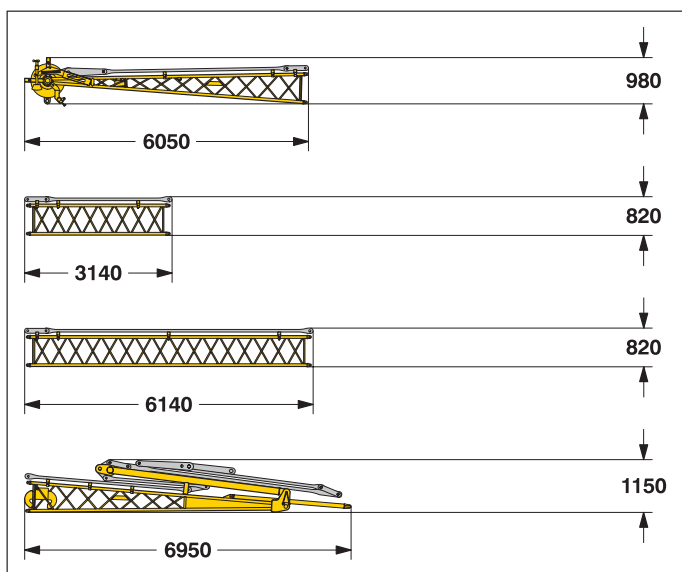

Cabeza de plumín fijo (N° 0806.xx)

Ancho	mm	1140
Peso*	kg	445

Tramo plumín fijo (N° 0806.xx) 3 m

Ancho	mm	950
Peso*	kg	110

Tramo plumín fijo (N° 0806.xx) 6 m

Ancho	mm	950
Peso*	kg	195

Pie de plumín fijo con caballete (N° 0806.xx)

Ancho	mm	1500
Peso*	kg	930

*) Incluye tirantes

Dimensiones y pesos de transporte

Plumín abatible (N° 1309.xx)

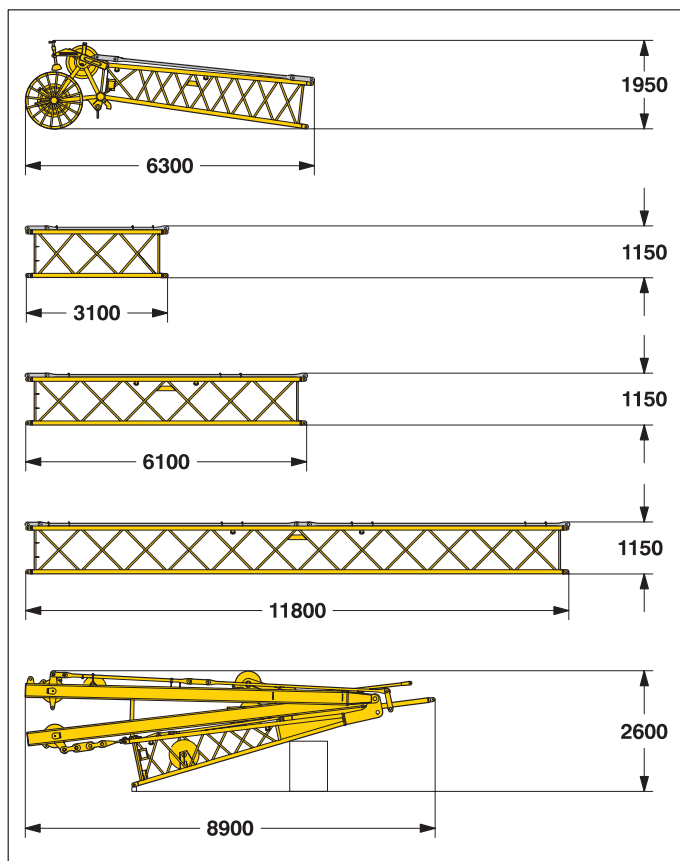

*) Incluye tirantes

Cabeza de plumín abatible (N° 1309.xx)

Ancho	mm	1500
Peso*	kg	1135

Tramo plumín abatible (N° 1309.xx) **3 m**

Ancho	mm	1500
Peso*	kg	420

Tramo plumín abatible (N° 1309.xx) **6 m**

Ancho	mm	1500
Peso*	kg	520

Tramo plumín abatible (N° 1309.xx) **11.7 m**

Ancho	mm	1500
Peso*	kg	960

Pie de plumín abatible con caballete (N° 1309.xx)

Ancho	mm	1700
Peso*	kg	4800

Dimensiones y pesos de transporte

Contrapeso

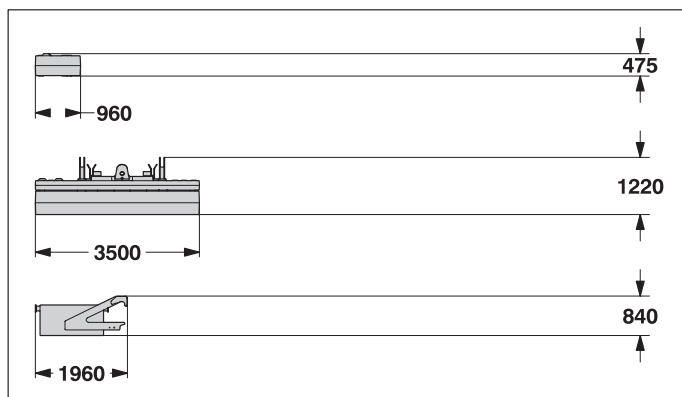

Contrapeso trasero 10x

Ancho	mm	850
Peso	kg	1500

Contrapeso trasero 1x

Ancho	mm	1050
Peso	kg	17300

Contrapeso central 2x

Ancho	mm	1640
Peso	kg	7500

Ganchos

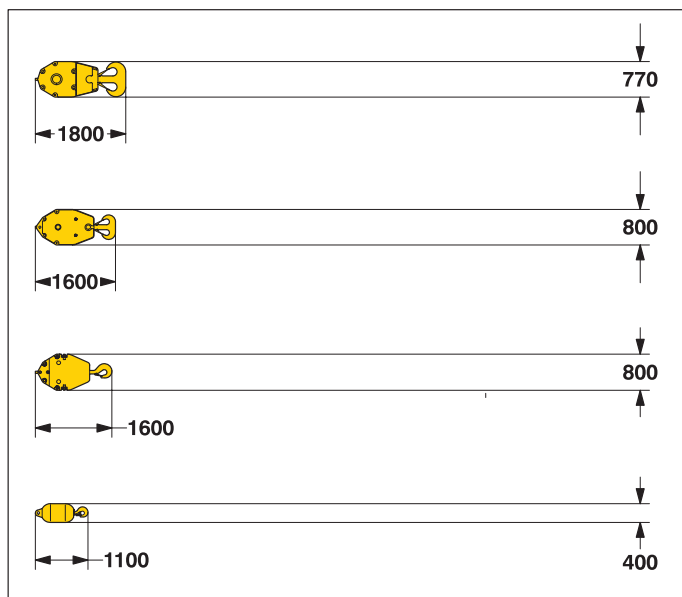

Gancho 100 t - 5 poleas

Ancho	mm	540	640	770
Peso	kg	1300	1800	2300

Gancho 80 t - 3 poleas

Ancho	mm	560
Peso	kg	2000

Gancho 40 t - 1 polea

Ancho	mm	300	400	500
Peso	kg	700	1100	1500

Gancho simple 12.5 t

Ancho	mm	400
Peso	kg	600

Descripción técnica



Motor

Potencia controlada de acuerdo a la norma ISO 9249, 240 kW (322 caballos) a 2000 r. p.m.
Tipo de motor — Liebherr D 926 TI-E
Capacidad de tanque — 800 l de capacidad con indicador continuo de nivel y de reserva.
De acuerdo con EPA CARB II/TIER II/ y 97/68 EC TIER II OFF-ROAD.



Sistema hidráulico

La bomba doble de desplazamiento axial y caudal variable permite realizar todos los movimientos de forma simultánea. Para reducir picos de presión hidráulica se incorpora una válvula de corte en la bomba. Todos los filtros están controlados electrónicamente en el monitor.
Existe la posibilidad de utilizar aceites sintéticos ecológicos (biodegradables).
Presión — máx. 350 bar
Capacidad de tanque — 650 l



Cabestrante de plumín abatible

Tiro del cable — máx. 105 kN
Diámetro del cable — 20 mm
Tiempo de subida/bajada de 15° a 78° — 48 s



Cabestrante de pluma

Tiro del cable — máx. 126 kN
Diámetro del cable — 20 mm
Tiempo de subida/bajada de 15° a 86° — 44 s



Mecanismo de giro

Corona de giro de rodamiento interno y dientes exteriores, accionado por un reductor con motor hidráulico de pistones axiales, frenos multi-disco accionados hidráulicamente, engranaje planetario y piñón.
A través del giro libre se reduce el desgaste al mínimo. Como alternativa se puede controlar la velocidad de giro con los joysticks y se cerrará el freno de parada de discos múltiples automáticamente en la posición cero.
Velocidad de giro: 0 – 3.15 r.p.m., regulable sin escalonamientos.



Cabestrantes principales

Tiro de cable (en la 1ª capa) — máx. 175 kN
Tiro de cable (en la 7ª capa) — 120 kN
Diámetro del cable — 26 mm
Diámetro del tambor — 580 mm
Velocidad cable m/min — 0 – 136
Longitud de cable en 7 capas — 489 m

Los cabestrantes destacan por su diseño compacto y su facilidad de ensamblaje. Consisten de un engranaje planetario interno, bañado en aceite y de mantenimiento mínimo. La carga se sostiene por el sistema hidráulico, además de un factor de seguridad adicional, con un freno de discos múltiples (freno de parada).

Para los cabestrantes se utiliza motores de control de alta presión y caudal variable. Este sistema dispone de sensores que automáticamente ajustan del caudal de aceite para alcanzar la máxima velocidad dependiendo de la carga suspendida.

Opción: Cabestrantes con caída libre

En el cabrestante con caída libre se realiza la función de freno y de embrague solo con el freno de trabajo. Este freno es un freno de discos múltiples de diseño compacto, de bajo desgaste y sin necesidad de mantenimiento.



Mecanismo de traslación

El mecanismo de traslación se realiza a través de un motor de pistones axiales, frenos de discos múltiples de bajo mantenimiento y dos tensores hidráulicos de cadenas.

Tejas planas — 900mm
Velocidad de traslación — 0 – 1.35 km/h



Sistema de control electrónico

El sistema de control está diseñado y fabricado por Liebherr para trabajar en las obras y en condiciones medio ambientales más duras tales como cambios bruscos de temperatura, alta humedad, vibraciones e interferencias eléctrico-magnéticas.

Todos los datos relevantes de la máquina se muestran en un monitor de alta resolución. Información estándar se visualiza a través de símbolos gráficos, los mensajes de error aparecen en forma de mensajes de texto claros y concisos. (disponible en más de diez idiomas diferentes)

Las grúas vienen equipadas con un control proporcional sin escalas, que permiten realizar todos los movimientos posibles simultáneamente.

Un sistema de emergencia, que permite un manejo limitado en casos de urgencia, está incluido en el suministro de la grúa.

El manejo se lleva a cabo a través de dos joysticks multi-direccionales, el derecho para el cabestrante I y la pluma y el izquierdo para el cabestrante II y el giro.

Las cadenas se activan por medio de unos pedales centrales que además llevan unas palancas de mano.

Opción:

Mando doble T bi-direccional para un manejo simultáneo de la pluma y el plumín.



Emisión de sonidos

La emisión de sonidos corresponde a la directiva 2000/14 de la normativa CE de emisión de sonidos en el exterior.

Configuraciones de pluma

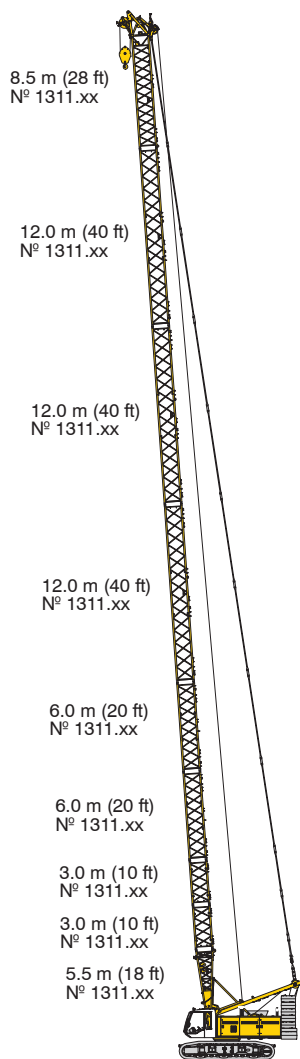

Pluma principal Nº 1311.xx — 68 m

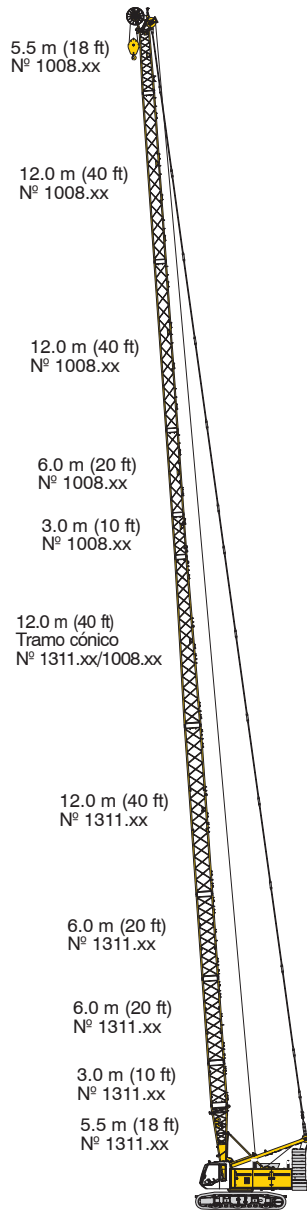

Combinación máx — 83 m
Pluma principal Nº 1311.xx — 44.5 m
Tramo cónico Nº 1311/1008.xx — 12.0 m
Plumín abatible Nº 1008.xx — 26.5 m

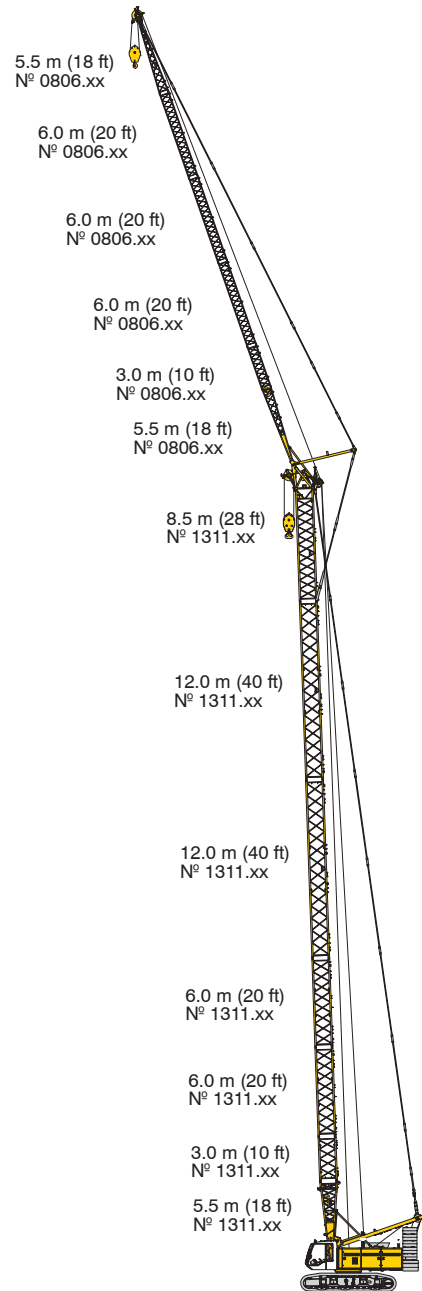

Combinación máx — 85.0 m
Pluma principal Nº 1311.xx — 53.0 m
Plumín fijo Nº 0806.xx — 32.0 m

Configuraciones de pluma

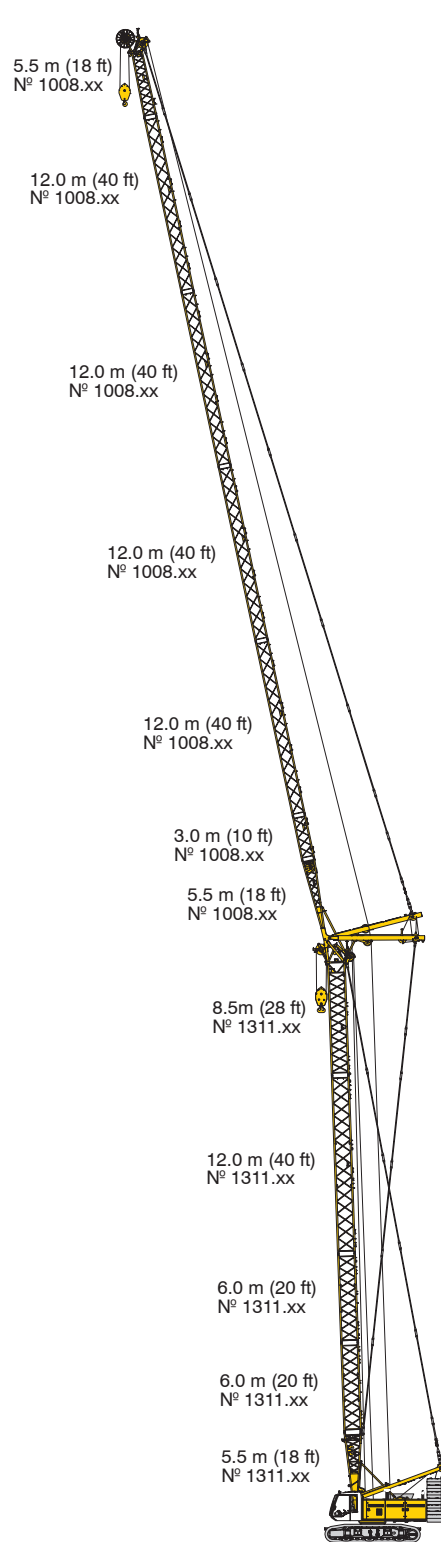

Combinación máx ————— 100.0 m
 Pluma principal N° 1311.xx — 38.0 m
 Plumín abatible N° 1008.xx — 62.0 m
 Pluma principal N° 1311.xx — 41.0 m
 Plumín abatible N° 1008.xx — 44.0 m

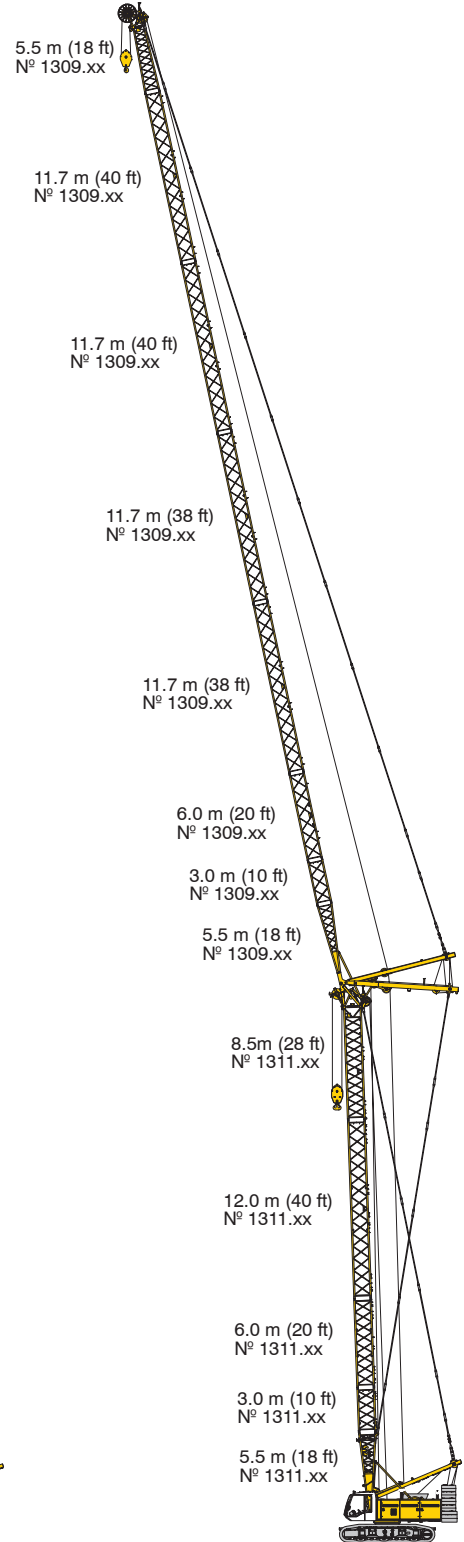

Combinación máx ————— 101.8 m
 Pluma principal N° 1311.xx — 35.0 m
 Plumín abatible N° 1309.xx — 66.8 m
 Pluma principal N° 1311.xx — 38.0 m
 Plumín abatible N° 1309.xx — 46.1 m

Sistema de auto montaje

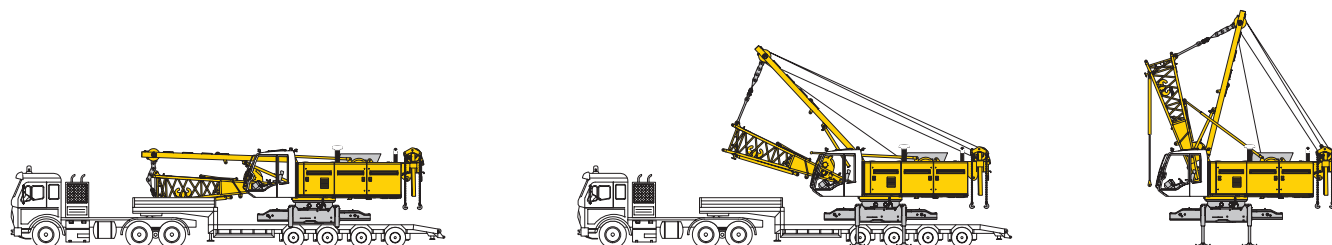

Descarga de la máquina base (opcional)

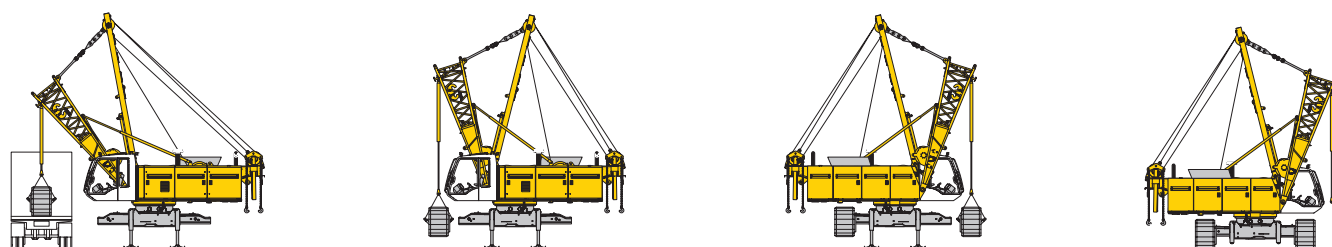

Descarga y montaje de las cadenas

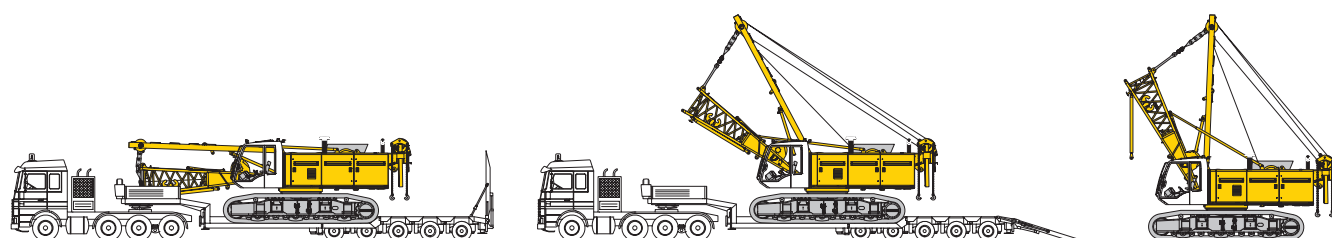

Descarga de la máquina base (estándar)

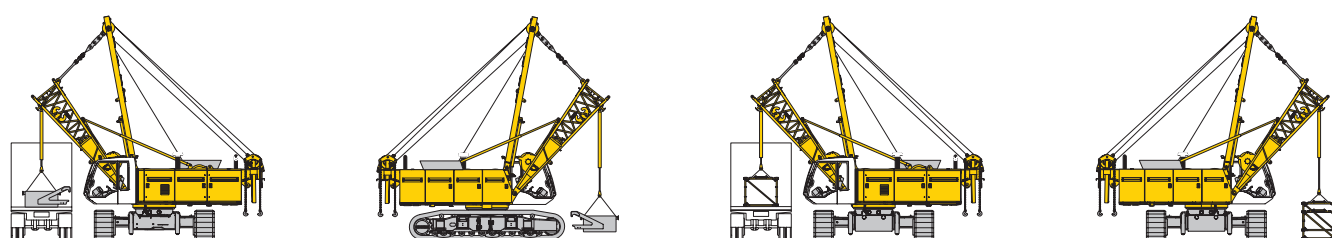

Descarga y montaje del contrapeso central

Descarga y montaje de la pluma

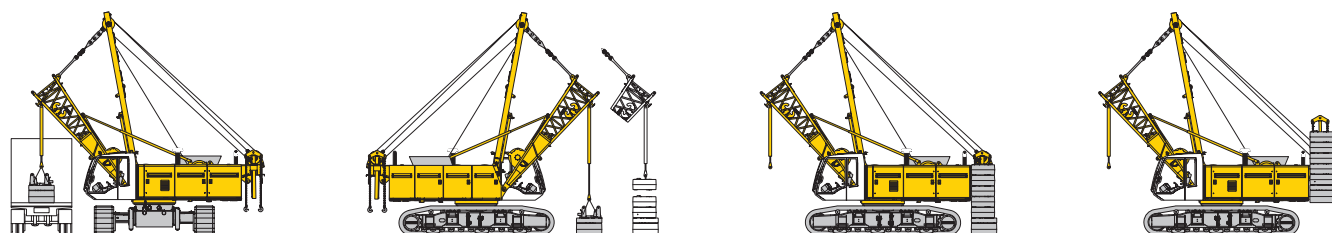

Descarga y montaje del contrapeso

Elevación de la pluma a posición de trabajo

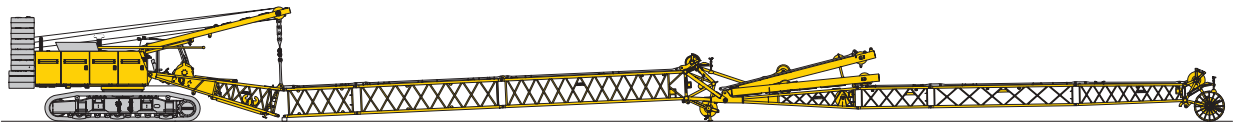

Montaje de la pluma

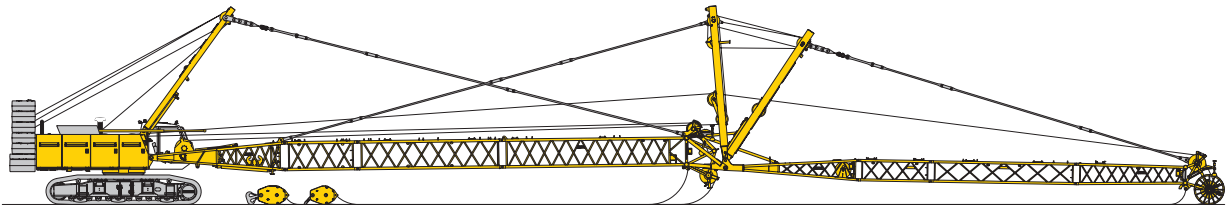

Montaje de los cables de la pluma principal y del plumín abatible

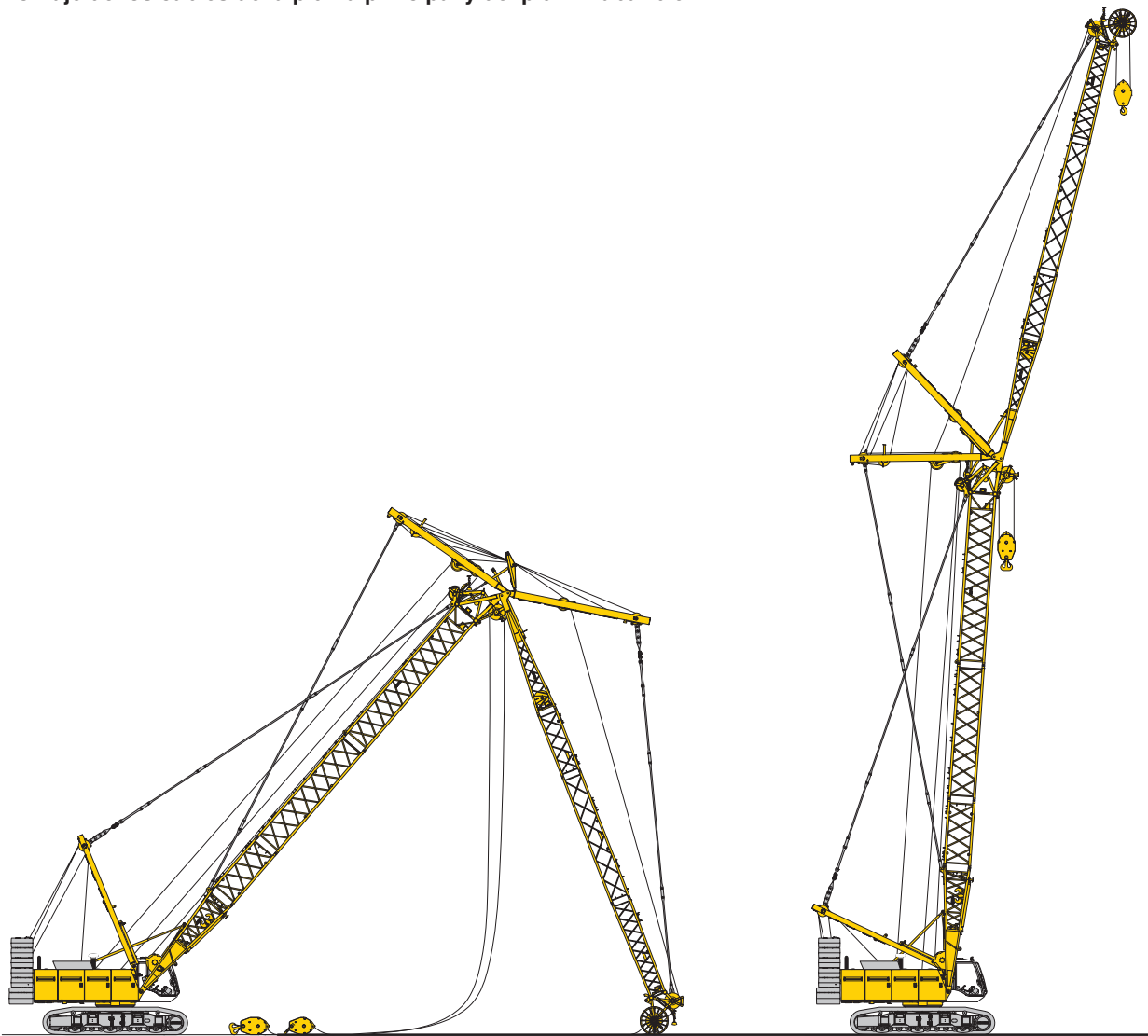

Elevación de la pluma principal y del plumín abatible

Posición de trabajo

Radio de trabajo - pluma principal (N° 1311.xx) **86° - 15°** **32.3 t contrapeso y 15 t contrapeso central**

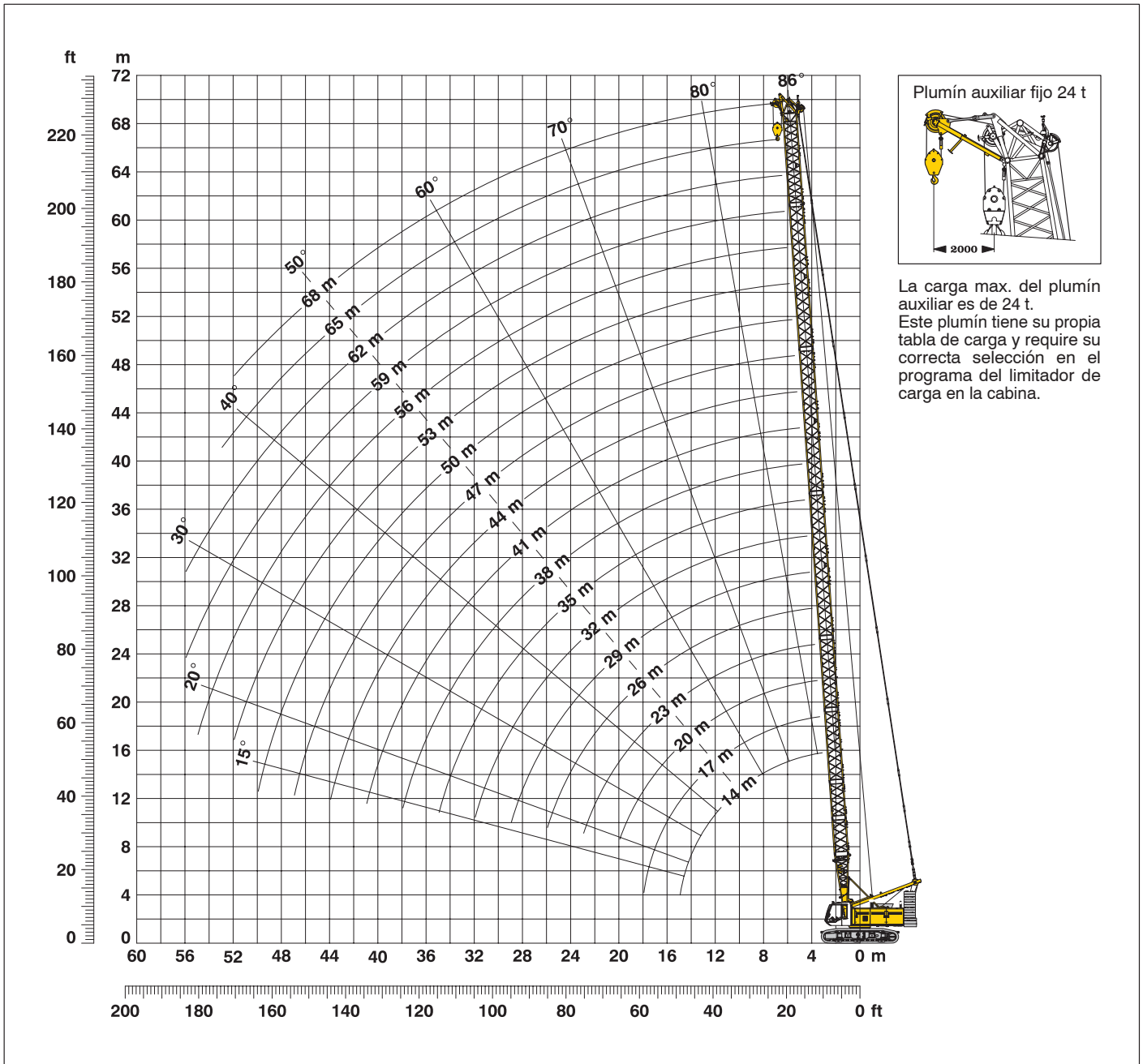

Configuración de pluma principal (Tabla 1 - N° 1311.xx)

Configuración para longitudes de pluma (17 m - 80 m)

Pie de pluma	Longitud	Número de tramos de pluma principal																		
		1	1	1	1	1	1	1	1	1	1	1	1	1	1	1	1	1	1	
Tramo pluma	5.5 m		1																	
Tramo pluma	3.0 m			1																
Tramo pluma	6.0 m				1															
Tramo pluma	12.0 m					1														
Cabeza pluma	8.5 m	1	1	1	1	1	1	1	1	1	1	1	1	1	1	1	1	1	1	
Longitud pluma (m)		14	17	20	23	26	29	32	35	38	41	44	47	50	53	56	59	62	65	68

Tabla de cargas para pluma principal (N° 1311.xx)

Capacidades de carga indicadas en toneladas para pluma con longitud de (14 m – 68 m) – con cabestrantes de 120 kN contrapeso de 32.3 t y contrapeso central de 15 t

Radio	Longitud pluma en (m)										Radio
	14	20	26	32	38	44	50	56	62	68	
(m)	t	t	t	t	t	t	t	t	t	t	(m)
3.1	104.5										3.1
4	103.7	94.1	78.0								4
5	82.2	73.2	65.8	59.8	50.5						5
6	65.8	59.7	54.6	50.2	46.4	35.2	27.7				6
7	54.8	50.3	46.5	43.2	40.2	34.3	26.9	18.6	15.2	10.9	7
8	46.8	43.4	40.4	37.8	35.3	33.1	26.2	18.2	14.9	10.8	8
9	39.5	38.1	35.6	33.5	31.5	29.7	25.2	17.9	14.6	10.5	9
10	34.1	33.9	31.8	30.0	28.3	26.8	24.5	17.5	14.2	10.2	10
12	26.6	26.7	26.1	24.8	23.4	22.3	21.1	16.9	13.5	9.7	12
14	21.6	21.7	21.6	20.9	19.9	18.9	17.9	15.9	13.0	9.3	14
16		18.1	18.0	18.0	17.1	16.3	15.5	14.7	12.1	8.9	16
18		15.5	15.4	15.3	15.0	14.3	13.5	12.8	10.9	8.4	18
20		13.3	13.3	13.2	13.0	12.6	12.0	11.4	10.6	8.1	20
22			11.7	11.6	11.4	11.2	10.6	10.1	9.5	7.8	22
24			10.3	10.3	10.1	9.9	9.5	9.0	8.4	7.3	24
26			9.1	9.1	8.9	8.8	8.5	8.0	7.5	6.9	26
28				8.2	8.0	7.8	7.6	7.2	6.7	6.2	28
30				7.3	7.1	7.0	6.7	6.5	6.0	5.5	30
32				6.6	6.4	6.3	6.0	5.8	5.4	4.9	32
34					5.8	5.6	5.4	5.2	4.8	4.4	34
36					5.2	5.1	4.8	4.7	4.3	3.9	36
38					4.7	4.6	4.4	4.2	3.9	3.4	38
40						4.1	3.9	3.7	3.5	3.0	40
42						3.7	3.5	3.3	3.1	2.7	42
44						3.3	3.1	3.0	2.7	2.3	44
46							2.8	2.6	2.4	2.0	46
48							2.5	2.3	2.1		48
50							2.2	2.0			50

Esta tabla de cargas sirve únicamente como información. Para trabajos de elevación consultar la tabla de carga de la cabina o el manual.

Pluma - L de largo alcance (N° 1311 / 1008.xx) **50 m - 83 m**

Radio de trabajo 86° - 15°

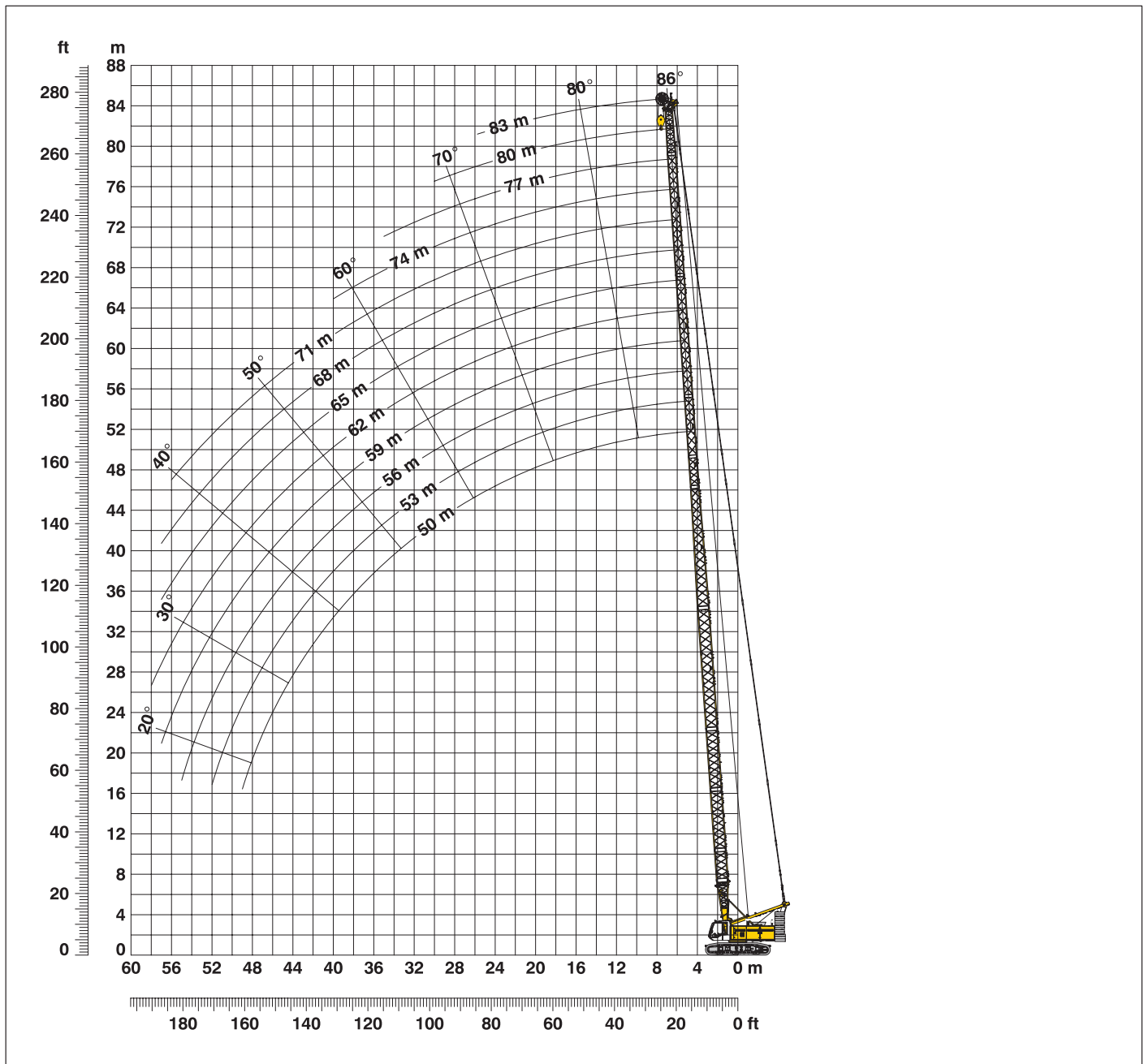

Configuración de pluma L con pluma principal de 32.5 m (N° 1311.xx / N° 1008.xx)

Configuración para longitud de pluma (50 m – 83 m)

	Longitud	Número de tramos de pluma y de plumín abatible											
		1	1	1	1	1	1	1	1	1	1	1	1
Pie de pluma	5.5 m	1	1	1	1	1	1	1	1	1	1	1	1
Tramo pluma	3.0 m	1	1	1	1	1	1	1	1	1	1	1	1
Tramo pluma	6.0 m	2	2	2	2	2	2	2	2	2	2	2	2
Tramo pluma	12.0 m	1	1	1	1	1	1	1	1	1	1	1	1
Tramo cónico	12.0 m	1	1	1	1	1	1	1	1	1	1	1	1
Tramo plumín abatible	3.0 m		1		1		1		1		1		1
Tramo plumín abatible	6.0 m			1	1			1	1			1	1
Tramo plumín abatible	12 m					1	1	1	1	2	2	2	2
Cabeza plumín abatible	5.5 m	1	1	1	1	1	1	1	1	1	1	1	1
Longitud máx. pluma L (m)		50	53	56	59	62	65	68	71	74	77	80	83

Tablas de cargas - pluma - L (N° 1311 / 1008.xx)

Pluma principal 32.5 m

Capacidad en toneladas: Contrapeso de 32.5 t y contrapeso central de 15 t				
Radio (m)	Longitud de pluma - L en (m)			
	50	62	74	83
5.2	t	t	t	t
6	27.0			
7	26.6	13.2		
8	25.5	12.8	6.3	
9	24.5	12.2	6.1	3.8
10	23.0	10.7	5.8	3.7
12	22.3	10.2	5.6	3.6
14	20.6	9.4	5.1	3.3
16	18.8	8.6	4.7	3.0
18	16.3	8.0	4.3	2.8
20	14.4	7.4	4.0	2.6
22	12.8	7.0	3.6	2.4
24	11.5	6.4	3.4	2.2
26	10.4	6.0	3.2	
28	9.3	5.7	3.0	
30	8.4	5.4	2.8	
32	7.5	5.2	2.6	
34	6.8	5.0	2.4	
36	6.2	4.7	2.2	
38	5.6	4.5	2.1	
40	5.2	4.3		
42	4.7	4.2		
44	4.3	3.9		
46	4.0	3.7		
48	3.6	3.5		
50	3.3	3.2		
55		2.9		
		2.3		

Pluma principal 44.5 m

Capacidad en toneladas: Contrapeso de 32.5 t y contrapeso central de 15 t				
Radio (m)	Longitud de pluma - L en (m)			
	62	68	74	83
6	t	t	t	t
7	16.1			
8	15.7	11.1	8.2	
9	15.0	10.7	8.0	5.0
10	14.5	9.9	7.6	4.9
12	13.8	9.4	7.2	4.6
14	12.8	8.4	6.6	4.3
16	11.0	7.8	6.2	4.1
18	10.3	7.3	5.8	3.8
20	9.6	6.7	5.5	3.5
22	9.1	6.2	5.1	3.3
24	8.5	5.7	4.8	3.1
26	8.0	5.3	4.6	2.9
28	7.7	4.9	4.3	2.7
30	7.4	4.6	4.1	2.5
32	6.9	4.4	3.9	2.4
34	6.3	4.3	3.7	2.3
36	5.7	4.1	3.5	2.1
38	5.2	3.9	3.3	
40	4.7	3.7	3.1	
42	4.3	3.4	3.0	
44	3.9	3.2	2.9	
46	3.5	3.0	2.7	
48	3.2	2.8	2.6	
50	2.9	2.7	2.5	
55	2.6	2.5	2.4	
	2.0			

Esta tabla de cargas sirve únicamente como información. Para trabajos de elevación consultar la tabla de carga de la cabina o el manual.

Configuración de pluma L con pluma principal de 44.5 m (N° 1311.xx / N° 1008.xx)

Configuración para longitud de pluma (62 m - 83 m)									
Pie de pluma	Longitud	Número de tramos de pluma y de plumín abatible							
		5.5 m	1	1	1	1	1	1	1
Tramo pluma	3.0 m	1	1	1	1	1	1	1	1
Tramo pluma	6.0 m	2	2	2	2	2	2	2	2
Tramo pluma	12.0 m	2	2	2	2	2	2	2	2
Tramo cónico	12.0 m	1	1	1	1	1	1	1	1
Tramo plumín abatible	3.0 m		1		1		1		1
Tramo plumín abatible	6.0 m			1	1			1	1
Tramo plumín abatible	12.0 m					1	1	1	1
Cabeza plumín abatible	5.5 m	1	1	1	1	1	1	1	1
Longitud máx. pluma L (m)		62	65	68	71	74	77	80	83

Radio de trabajo - plumín abatible (N° 1008.xx) 78° - 15°

Pluma principal 88° - 45°

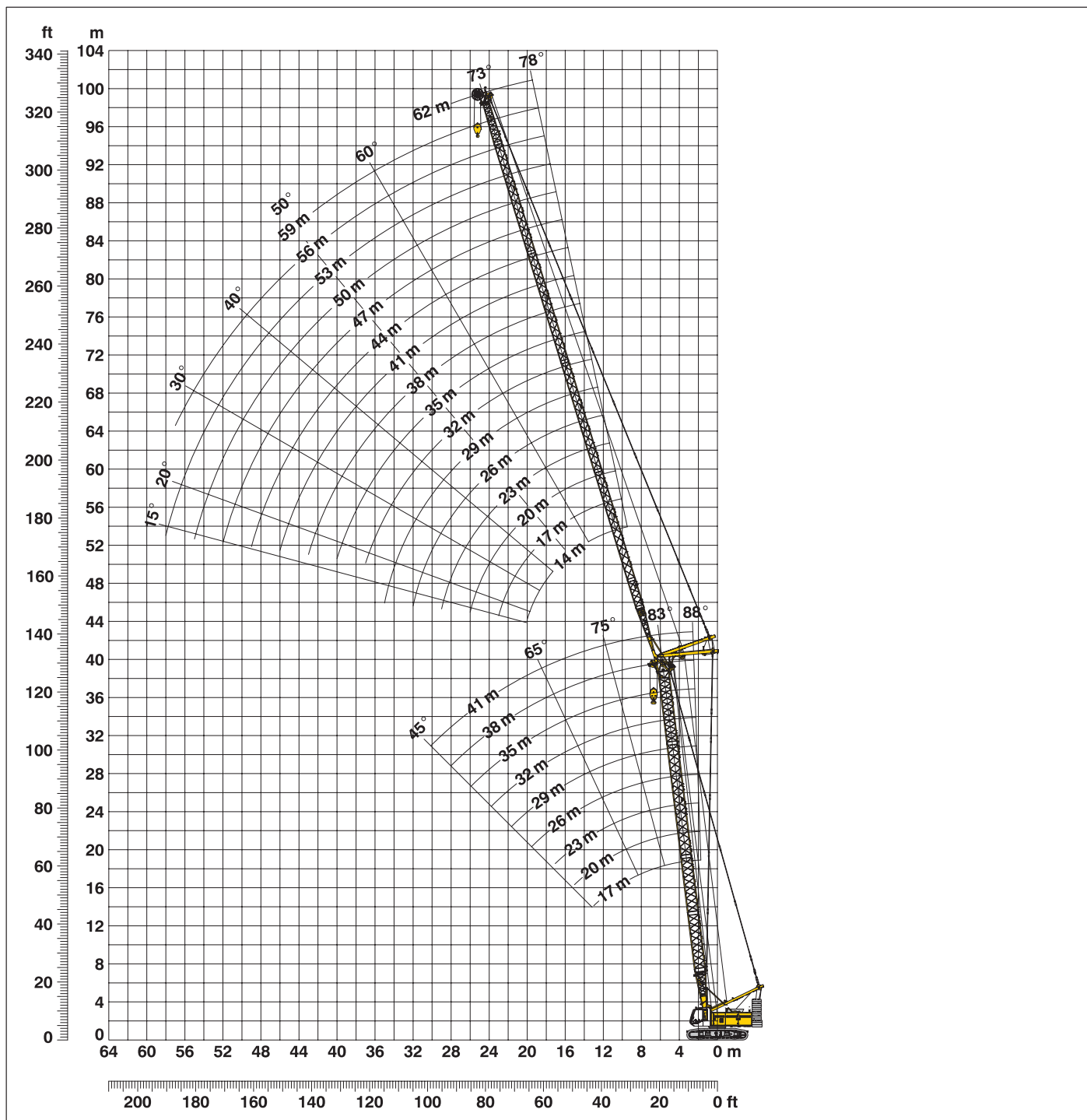

Configuración de pluma principal (17 m - 41 m) – vea tabla 1 en la pagina 12
Configuración de plumín abatible (14 m - 62 m)

	Longitud	Número de tramos de plumín abatible																
Pie de plumín abatible	5.5 m	1	1	1	1	1	1	1	1	1	1	1	1	1	1	1	1	1
Tramo plumín abatible	3.0 m	1		1		1		1		1		1		1		1		1
Tramo plumín abatible	6.0 m		1	1		1	1		1	1		1	1		1	1	2	2
Tramo plumín abatible	12.0 m				1	1	1	1	2	2	2	2	3	3	3	3	3	3
Cabeza plumín abatible	5.5 m	1	1	1	1	1	1	1	1	1	1	1	1	1	1	1	1	1
Longitud de plumín abatible (m)		14	17	20	23	26	29	32	35	38	41	44	47	50	53	56	59	62

Tablas de cargas - plumín abatible (N° 1008.xx)

Pluma principal con ángulo 88°

Pluma principal 17 m

Radio (m)	Longitud de plumín (m)							
	14	23	29	35	44	50	56	62
5.9	t	t	t	t	t	t	t	t
8	47.3							
9	39.8	27.9						
11	35.6	26.8	18.9					
13	29.3	24.0	17.7	13.3				
14	25.0	20.4	16.4	12.7	7.1			
15	23.2	19.4	15.7	12.4	7.1	5.4		
16	20.7	18.1	15.1	12.2	7.1	5.3	4.1	
20	16.2	16.9	14.5	11.3	7.0	5.2	4.0	2.9
24		13.5	12.2	10.2	6.5	4.6	3.6	2.6
26		9.6	9.8	9.0	6.0	4.3	3.4	2.3
28			9.1	8.6	5.8	4.1	3.2	2.2
30			8.1	8.2	5.7	4.0	3.1	2.1
36			6.9	7.8	5.5	3.9	3.1	2.1
44				5.5	5.1	3.7	2.8	
50					3.9	3.4	2.5	
55						2.9	2.3	
							2.2	

Pluma principal 23 m

Radio (m)	Longitud de plumín (m)							
	14	23	29	35	44	50	56	62
6.1	t	t	t	t	t	t	t	t
7	42.1							
8	39.9							
10	37.1	24.9						
11	30.3	22.7	16.9					
13	27.7	21.7	16.3	12.3				
14	23.7	19.5	15.3	11.2	7.2			
15	22.1	18.7	14.7	11.0	7.0	5.2		
17	20.7	17.6	14.2	10.8	6.9	5.0	3.8	
20		15.8	13.4	10.3	6.5	4.8	3.7	2.8
24		13.5	11.0	9.6	6.1	4.4	3.5	2.5
28		10.1	9.6	8.7	5.6	4.1	3.2	2.2
30			8.1	7.9	5.4	3.9	3.0	2.0
36			7.3	7.5	5.3	3.7	3.0	
44				5.9	5.0	3.5	2.7	
50					4.2	3.3	2.5	
55						3.1	2.3	
							2.2	

Pluma principal 29 m

Radio (m)	Longitud de plumín (m)							
	14	23	29	35	44	50	56	62
6.3	t	t	t	t	t	t	t	t
9	33.7							
10	28.9	20.6						
11	27.4	19.8	15.1					
13	25.7	18.9	14.7	10.7				
14	22.5	17.4	13.8	10.4	6.6			
16	21.0	16.7	13.4	10.1	6.5	4.8		
17	18.2	15.2	12.6	9.7	6.2	4.6	3.6	
24		14.6	12.4	9.4	6.0	4.5	3.5	2.6
26		8.5	9.1	8.1	5.3	3.9	3.1	2.1
28			8.3	7.8	5.2	3.8	3.0	2.0
30			7.6	7.3	5.1	3.7	2.9	
36			6.8	6.8	5.0	3.6	2.8	
44				5.0	4.7	3.4	2.6	
50					3.9	3.2	2.4	
55						3.0	2.2	
							2.1	

Pluma principal 35 m

Radio (m)	Longitud de plumín (m)							
	14	23	29	35	44	50	56	62
6.5	t	t	t	t	t	t	t	t
9	24.9							
10	21.6	16.1						
11	20.5	15.6	12.5					
13	19.4	14.9	12.2	9.1				
14	17.6	13.8	10.4	8.9	5.8			
16	16.7	13.3	10.2	8.7	5.8	4.3		
17	15.2	12.2	9.4	8.3	5.5	4.2	3.3	
20	9.3	10.4	9.2	8.0	5.4	4.1	3.2	2.3
22		9.2	8.3	7.4	5.2	3.9	3.0	2.2
24		8.4	7.9	7.0	5.0	3.7	2.9	2.0
30		7.2	7.3	6.6	4.8	3.6	2.8	
36			5.5	5.5	4.5	3.3	2.6	
46				4.3	3.9	3.1	2.4	
48					3.1	2.6	2.1	
50						2.5		
						2.3		

Pluma principal 38 m

Radio (m)	Longitud de plumín (m)							
	14	23	29	35	44	50	56	62
6.6	t	t	t	t	t	t	t	t
9	21.6							
10	19.2	14.6						
11	18.3	14.2	10.1					
13	17.4	13.5	10.0	8.2				
15	15.6	12.5	9.5	8.0	5.3			
16	14.1	10.2	8.9	7.7	5.2	4.0		
17	13.7	9.7	8.6	7.6	5.1	3.9	3.0	
20	8.3	9.3	8.3	7.3	5.0	3.9	3.0	2.2
24		8.0	7.4	6.7	4.8	3.7	2.9	2.0
30		6.3	6.5	6.0	4.5	3.4	2.7	
36			5.0	5.1	4.1	3.2	2.5	
42				4.2	3.6	2.9	2.3	
46					3.0	2.6	2.1	
50					2.6	2.4		
						2.1		

Pluma principal 41 m

Radio (m)	Longitud de plumín (m)							
	14	23	29	35	44			
6.8	t	t	t	t	t			
9	19.1							
10	17.2	13.0						
12	16.5	12.8	9.0					
13	14.8	10.4	8.8	7.2				
14	14.1	9.9	8.6	7.1	4.9			
15	13.3	9.4	8.4	7.0	4.8			
16	12.7	9.0	8.1	6.9	4.8			
17	12.5	8.5	7.7	6.8	4.8			
24	7.5	8.0	7.5	6.6	4.7			
30		5.4	5.7	5.3	4.2			
36			4.6	4.6	3.7			
38				3.9	3.3			
42					3.1			
46					2.7			
					2.3			

Capacidades de cargas indicadas en toneladas, con plumín abatible (N° 1008.xx), 32.3 t contrapeso y contrapeso central de 15 t. Estas tablas de cargas sirven únicamente como información. Para trabajos de elevación consultar las tablas de cargas de la cabina o el manual.

Tablas de cargas - plumín abatible (Nº 1008.xx)

Pluma principal con ángulo 83°

Pluma principal 17 m

Radio (m)	Longitud de plumín (m)							
	14	23	29	35	44	50	56	62
8.6	35.8	t	t	t	t	t	t	t
12	26.0	24.1						
13	24.0	22.4	17.1					
15	20.9	19.5	16.1	12.4				
16	19.5	18.3	15.5	12.2				
18		16.3	14.4	11.2	7.0			
20		14.6	13.2	10.6	6.7	4.8		
22		13.1	12.2	10.1	6.4	4.5	3.6	
24		11.2	10.6	9.6	6.1	4.4	3.4	2.4
26		9.7	9.9	9.1	5.9	4.2	3.3	2.3
28			9.3	8.8	5.8	4.1	3.2	2.2
32			7.1	7.9	5.6	3.9	3.1	2.0
38				5.7	5.2	3.6	2.8	
46					4.1	3.4	2.5	
50						3.2	2.4	
55							2.3	

Pluma principal 23 m

Radio (m)	Longitud de plumín (m)							
	14	23	29	35	44	50	56	62
9.4	30.7	t	t	t	t	t	t	t
12	24.3	22.5						
14	21.0	19.6	15.7					
16	18.4	17.2	14.8	11.0				
18	16.5	15.4	13.9	10.5				
19		14.6	13.5	10.3	6.5			
20		13.8	13.0	10.1	6.3	4.6		
22		12.6	11.2	9.7	6.1	4.4	3.4	
24		11.5	10.7	9.3	5.8	4.2	3.3	2.3
26		10.5	9.9	8.9	5.7	4.1	3.2	2.2
30			8.5	8.2	5.5	3.9	3.0	2.1
32			7.6	7.7	5.4	3.8	3.0	
38				6.1	5.1	3.6	2.8	
46					4.4	3.3	2.5	
50						3.3	2.4	
55							2.3	

Pluma principal 29 m

Radio (m)	Longitud de plumín (m)							
	14	23	29	35	44	50	56	62
10.1	26.5	t	t	t	t	t	t	t
13	21.0	19.6						
15	18.4	17.2	13.9					
17	16.3	15.3	13.3	9.9				
19	14.7	13.7	12.6	9.5	6.0			
22		11.6	10.9	9.0	5.7	4.2		
24		10.9	10.3	8.7	5.5	4.0	3.2	
26		9.8	9.6	8.4	5.4	3.9	3.1	2.1
28		8.0	8.8	8.1	5.3	3.8	3.0	2.1
32			6.9	7.2	5.1	3.6	2.8	
38				5.3	4.9	3.4	2.6	
48					3.5	3.2	2.4	
50						3.2	2.3	
60							2.1	

Pluma principal 35 m

Radio (m)	Longitud de plumín (m)							
	14	23	29	35	44	50	56	62
10.8	22.4	t	t	t	t	t	t	t
14	18.3	14.8						
16	16.2	13.8	11.2					
17	15.3	13.3	10.8	8.5				
20	10.1	11.2	9.8	8.1	5.3			
22		10.6	9.3	7.7	5.2	3.8		
24		9.6	8.8	7.3	5.0	3.7	2.9	
28		7.2	7.8	6.7	4.8	3.5	2.8	
34			5.4	6.1	4.6	3.3	2.6	
38				5.0	4.4	3.2	2.5	
40				4.3	4.3	3.1	2.4	
48					3.5	2.9	2.2	
50						2.9	2.2	
55							2.1	

Pluma principal 38 m

Radio (m)	Longitud de plumín (m)							
	14	23	29	35	44	50	56	62
11.2	19.4	t	t	t	t	t	t	t
14	17.1	13.2						
16	15.7	12.4	9.9					
18	14.0	11.2	9.4	7.6				
20	12.7	10.1	8.8	7.3	4.9			
22		9.3	8.2	6.9	4.8	3.6		
24		8.5	7.7	6.6	4.6	3.6	2.8	
28		6.6	6.9	6.0	4.4	3.4	2.6	
34			5.0	5.5	4.1	3.2	2.5	
40				4.1	3.8	3.0	2.3	
48					3.3	2.8	2.1	
50						2.7	2.1	
55						2.5		

Pluma principal 41 m

Radio (m)	Longitud de plumín (m)							
	14	23	29	35	44	50	56	62
11.5	17.0	t	t	t	t	t	t	t
15	14.5	11.0						
16	14.0	10.6	8.7					
18	13.2	9.8	8.3	6.7				
20	12.3	8.9	7.7	6.4				
22		8.1	7.2	6.1	4.5			
28		5.8	6.0	5.3	4.1			
34			4.6	4.8	3.7			
40				3.8	3.5			
42					3.4			
44					3.3			
46					3.2			
48					3.0			

Capacidades de cargas indicadas en toneladas, con plumín abatible (Nº 1008.xx), 32.3 t contrapeso y contrapeso central de 15 t. Estas tablas de cargas sirven únicamente como información. Para trabajos de elevación consultar las tablas de cargas de la cabina o el manual.

Tablas de cargas - plumín abatible (N° 1008.xx)

Pluma principal con ángulo 75°

Pluma principal 17 m

Radio (m)	Longitud de plumín (m)							
	14	23	29	35	44	50	56	62
12.8	t	t	t	t	t	t	t	t
17	23.0	17.2	16.2					
20	14.0	13.8	13.1					
22		12.4	11.9	10.4				
26		10.1	9.9	9.5	6.0			
28		9.1	9.0	8.8	5.9	4.1		
32			7.6	7.4	5.6	4.0	3.1	
34			7.0	6.9	5.6	3.9	3.0	2.0
40				5.4	5.2	3.6	2.8	
48					3.9	3.4	2.6	
50						3.4	2.5	
55						2.9	2.4	
60							2.3	

Pluma principal 23 m

Radio (m)	Longitud de plumín (m)							
	14	23	29	35	44	50	56	
14.4	t	t	t	t	t	t	t	
19	18.9	14.3	13.3					
20	13.6	12.7						
22		11.5	11.0					
24		10.5	10.0	9.5				
28		8.8	8.5	8.1	5.6			
30		8.0	7.9	7.5	5.5	3.9		
34			6.7	6.5	5.4	3.8	3.0	
36			6.2	6.0	5.3	3.7	2.9	
42				4.8	4.5	3.5	2.7	
50					3.4	3.2	2.5	
55						2.7	2.4	
60							2.1	

Pluma principal 29 m

Radio (m)	Longitud de plumín (m)							
	14	23	29	35	44	50	56	
15.9	t	t	t	t	t	t	t	
20	15.5	11.5						
22	12.4	11.3						
24		9.6	9.1					
26		8.8	8.4	7.9				
30		7.6	7.1	6.8	5.2			
32		7.0	6.6	6.3	5.2	3.7		
34			6.2	5.8	5.1	3.6	2.8	
36			5.8	5.5	4.9	3.6	2.8	
42				4.5	4.0	3.4	2.6	
50					3.1	2.8	2.4	
55						2.3	2.0	

Pluma principal 35 m

Radio (m)	Longitud de plumín (m)							
	14	23	29	35	44	50	56	
17.5	t	t	t	t	t	t	t	
22	12.9	9.5						
24	10.2	9.4	8.2					
28		8.7	7.4	6.6				
32		6.4	6.0	5.6	4.7			
34			5.6	5.2	4.6	3.4		
36			5.2	4.9	4.3	3.3	2.5	
38			4.9	4.5	4.0	3.3	2.5	
40				4.3	3.7	3.2	2.5	
44				3.7	3.2	2.9	2.4	
46					3.0	2.7	2.4	
50					2.6	2.4	2.0	

Pluma principal 38 m

Radio (m)	Longitud de plumín (m)							
	14	23	29	35	44	50	56	
18.3	t	t	t	t	t	t	t	
24	11.5	8.2						
26	8.9	7.6	7.1					
28		7.0	6.6	5.9				
32		6.0	5.6	5.3	4.0			
34		5.6	5.2	4.9	4.0	3.2		
36			4.9	4.6	3.9	3.1	2.3	
40			4.3	4.0	3.4	3.1	2.3	
46				3.3	2.8	2.5	2.2	
50					2.4	2.1		

Pluma principal 41 m

Radio (m)	Longitud de plumín (m)							
	14	23	29	35	44			
19	t	t	t	t	t			
24	10.5	7.7						
26	8.4	7.1	6.2					
28	7.7	6.6	5.9	4.9				
32		5.7	5.3	4.7	3.5			
34		5.3	4.9	4.5	3.5			
40			4.0	3.7	3.2			
46				3.0	2.5			
48					2.3			
50					2.2			

Capacidades de cargas indicadas en toneladas, con plumín abatible (N° 1008.xx), 32.3 t contrapeso y contrapeso central de 15 t. Estas tablas de cargas sirven únicamente como información. Para trabajos de elevación consultar las tablas de cargas de la cabina o el manual.

Tablas de cargas - plumín abatible (N° 1008.xx)

Pluma principal con ángulo 65°

Pluma principal 17 m

Radio (m)	Longitud de plumín (m)						
	14	23	29	35	44	50	56
17.7	t	t	t	t	t	t	t
22	15.4						
24	11.7						
28		10.4					
30		8.5	8.3				
36		7.8	7.6	7.4			
40			5.9	5.8	5.4		
42				5.0	4.7	3.6	
46				4.6	4.4	3.6	2.8
50					3.8	3.5	2.7
55					3.2	3.1	2.6
						2.6	2.4

Pluma principal 23 m

Radio (m)	Longitud de plumín (m)						
	14	23	29	35	44	50	56
20.3	t	t	t	t	t	t	t
24	11.9						
26	9.9						
30		8.6					
34		7.2	6.9				
38		6.1	5.9	5.6			
40			5.1	4.9	4.3		
42			4.7	4.5	4.0		
46				4.2	3.8	3.4	
50				3.6	3.3	3.0	2.6
55					2.9	2.6	2.3
						2.2	

Pluma principal 29 m

Radio (m)	Longitud de plumín (m)					
	14	23	29	35	44	50
22.8	t	t	t	t	t	t
28	9.2					
30	7.4	6.8				
36		6.4				
40		5.1	4.8	4.4		
42			4.1	3.8	3.2	
44			3.9	3.6	3.0	
48				3.3	2.8	2.5
50				2.9	2.4	2.1
					2.3	

Pluma principal 35 m

Radio (m)	Longitud de plumín (m)					
	14	23	29	35	44	50
25.4	t	t	t	t	t	t
30	7.1					
32	5.9					
34		5.0				
38		4.6	4.2			
40		4.0	3.7	3.3		
44			3.4	3.1		
48			3.0	2.7	2.2	
50				2.3		
				2.2		

Pluma principal 38 m

Radio (m)	Longitud de plumín (m)				
	14	23	29	35	44
26.6	t	t	t	t	t
32	6.2				
36	5.0	4.5			
38		3.9	3.5		
40		3.6	3.3		
44		3.4	3.0	2.7	
46			2.6	2.3	
			2.4	2.1	

Pluma principal 41 m

Radio (m)	Longitud de plumín (m)				
	14	23	29	35	44
27.9	t	t	t	t	t
32	5.3				
34	4.5				
38		3.7			
40		3.2	2.8		
42		3.0	2.6	2.3	
46		2.7	2.4	2.1	
			2.1		

Capacidades de cargas indicadas en toneladas, con plumín abatible (N° 1008.xx), 32.3 t contrapeso y contrapeso central de 15 t. Estas tablas de cargas sirven únicamente como información. Para trabajos de elevación consultar las tablas de cargas de la cabina o el manual.

Tablas de cargas - plumín abatible (N° 1008.xx)

Pluma principal con ángulo 45°

Pluma principal 17 m

Radio (m)	Longitud de plumín (m)								
	14	23	29	35	44				
t	t	t	t	t	t				
25.9	8.3								
28	7.6								
34		5.7							
36		5.2							
40			4.3						
42			4.0						
44				3.6					
48				3.1					
55					2.1				

Pluma principal 23 m

Radio (m)	Longitud de plumín (m)								
	14	23	29	35					
t	t	t	t	t					
30.2	5.9								
32	5.5								
38		4.1							
40		3.8							
44			3.1						
46			2.8						
48				2.4					
50				2.3					

Pluma principal 29 m

Radio (m)	Longitud de plumín (m)							
	14	23						
t	t	t						
34.4	4.0							
36	3.8							
42		2.7						
44		2.5						

Pluma principal 35 m

Radio (m)	Longitud de plumín (m)							
	14	17						
t	t	t						
38.7	2.5							
40	2.4							
42		2.1						

Capacidades de cargas indicadas en toneladas, con plumín abatible (N° 1008.xx), 32.3 t contrapeso y contrapeso central de 15 t. Estas tablas de cargas sirven únicamente como información. Para trabajos de elevación consultar las tablas de cargas de la cabina o el manual.

Radio de trabajo - plumín abatible (N° 1309.xx) 78° - 15°

Pluma principal 88° - 45°

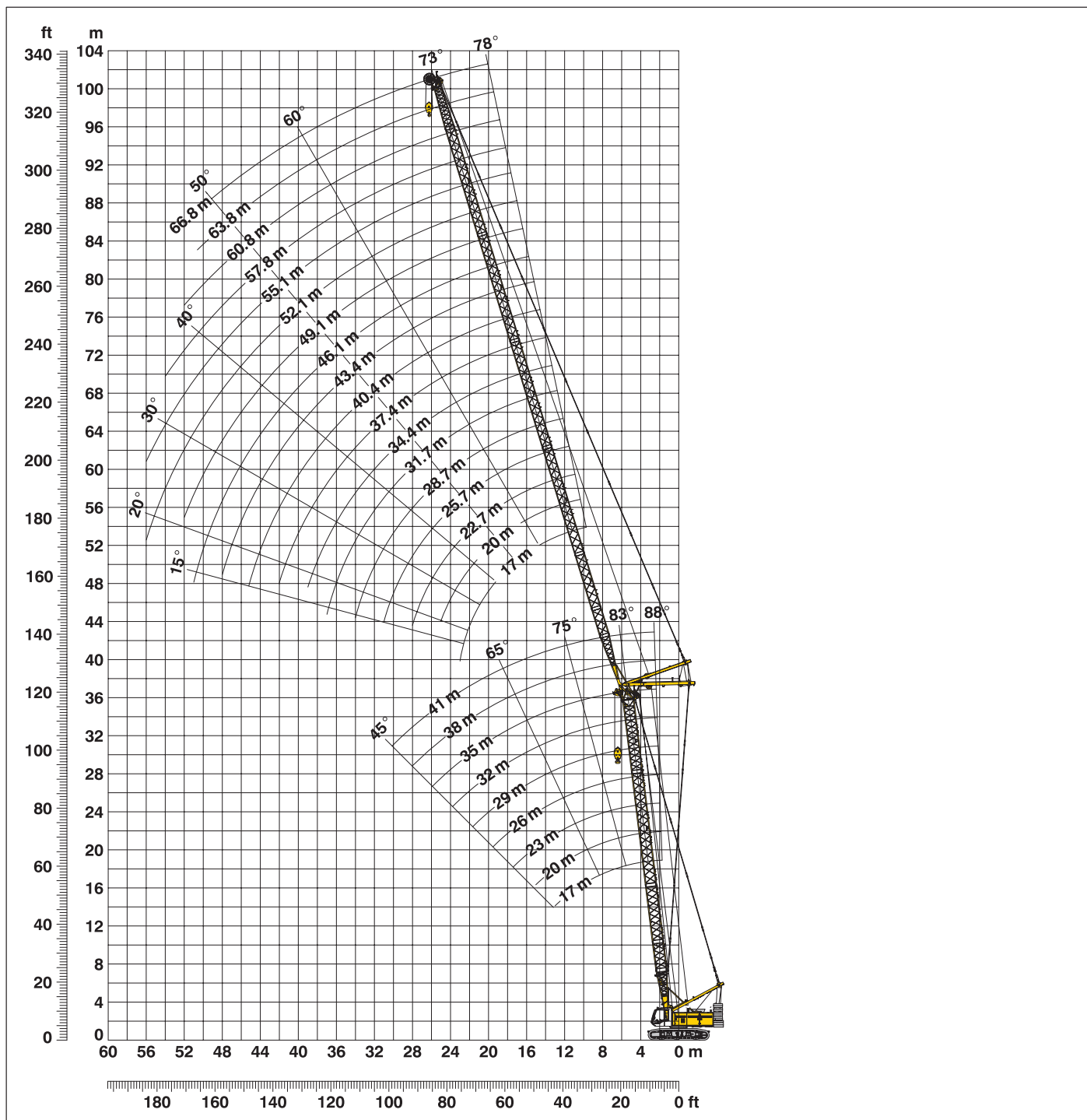

Configuración de pluma principal (17 m - 41 m) – vea tabla 1 en la pagina 12

Configuración de plumín abatible (17 m - 66.8 m)

	Longitud	Número de tramos de plumín abatible																
		17	22.7	25.7	28.7	31.7	34.4	37.4	40.4	43.4	46.1	49.1	52.1	55.1	57.8	60.8	63.8	66.8
Pie de plumín abatible	5.5 m	1	1	1	1	1	1	1	1	1	1	1	1	1	1	1	1	1
Tramo plumín abatible	3.0 m			1	1			1	1			1	1			1	1	
Tramo plumín abatible	6.0 m	1			1	1			1	1			1	1				1
Tramo plumín abatible	11.7 m		1	1	1	1	2	2	2	2	3	3	3	3	4	4	4	4
Cabeza plumín abatible	5.5 m	1	1	1	1	1	1	1	1	1	1	1	1	1	1	1	1	1
Longitud de plumín abatible (m)		17	22.7	25.7	28.7	31.7	34.4	37.4	40.4	43.4	46.1	49.1	52.1	55.1	57.8	60.8	63.8	66.8

Tablas de cargas - plumín abatible (N° 1309.xx)

Pluma principal con ángulo 88°

Pluma principal 17 m

Radio (m)	Longitud de plumín (m)							
	17	22.7	28.7	34.4	46.1	52.1	57.8	66.8
6.5	45.7							
8	38.8	35.3						
9	34.7	32.7	27.5					
11	28.7	27.3	24.8	21.3				
13	24.4	23.3	22.0	19.2	13.8			
14	22.7	21.7	20.6	18.2	13.3	10.1		
15	21.2	20.3	19.3	17.5	12.9	10.0	8.2	
17	18.7	17.9	17.1	15.7	11.6	9.5	8.0	5.4
18	17.4	16.9	16.1	15.0	11.3	9.3	7.8	5.4
19	16.2	16.0	15.3	14.4	11.1	9.0	7.7	5.2
24		12.1	11.3	11.2	9.1	7.9	6.7	4.8
30			9.0	8.9	7.6	6.7	5.8	4.4
36				6.9	6.3	5.7	5.0	4.0
46					4.5	4.2	3.8	3.2
50						3.7	3.4	2.8
55							2.9	2.3

Pluma principal 23 m

Radio (m)	Longitud de plumín (m)							
	17	22.7	28.7	34.4	46.1	52.1	57.8	66.8
6.7	38.3							
7	38.1							
8	35.3	29.9						
10	29.6	26.8	22.6					
11	27.1	25.4	21.7	18.4				
13	23.2	22.1	19.7	17.0	11.8			
14	21.6	20.6	18.7	16.3	11.6	9.0		
16	19.0	18.2	17.1	15.0	11.0	8.7	7.2	
18	17.0	16.2	15.3	13.8	10.2	8.4	6.9	4.9
19	16.2	15.4	14.4	13.3	9.9	8.1	6.8	4.8
24		11.3	10.5	10.1	8.4	7.2	6.0	4.4
30			8.1	7.6	6.8	6.1	5.4	4.0
36				6.2	5.5	5.1	4.6	3.6
46					4.0	3.6	3.3	2.7
50						3.2	2.9	2.3
55							2.5	

Pluma principal 29 m

Radio (m)	Longitud de plumín (m)							
	17	22.7	28.7	34.4	46.1	52.1	57.8	66.8
7	30.6							
9	27.4	22.4						
10	25.8	21.8	18.8					
11	24.5	21.1	18.0	15.3				
13	21.7	19.2	16.6	14.3	9.8			
15	19.3	17.4	15.2	13.3	9.4	7.8		
16	18.1	16.5	14.6	12.8	9.2	7.6	6.2	
18	16.1	15.0	13.3	11.5	8.6	7.2	5.9	4.3
19	15.1	14.0	12.6	11.3	8.4	7.0	5.8	4.3
24		10.3	9.9	9.0	7.2	6.1	5.2	3.9
30			7.7	7.0	5.9	5.3	4.6	3.5
36				5.8	4.9	4.4	3.9	3.1
46					3.7	3.2	2.9	2.2
48						3.1	2.7	2.1
50							2.9	2.5
55								2.2

Pluma principal 35 m

Radio (m)	Longitud de plumín (m)							
	17	22.7	28.7	34.4	46.1	52.1	57.8	66.8
7.2	22.3							
9	20.3	17.4						
10	19.3	16.7	14.1					
11	18.3	15.9	13.6	11.3				
14	15.3	14.0	12.1	10.2	7.3			
15	14.4	13.3	11.4	9.9	7.1	5.8		
16	13.5	12.7	10.9	9.6	6.9	5.7	4.7	
18	12.4	10.3	10.2	8.8	6.4	5.4	4.5	3.3
19	10.6	9.9	9.7	8.5	6.2	5.2	4.4	3.2
24		7.9	7.8	7.0	5.4	4.6	3.8	2.8
30			6.0	5.6	4.5	4.0	3.4	2.4
36				4.7	3.8	3.4	2.9	2.2
38					3.6	3.2	2.7	2.0
46						2.8	2.4	2.0
48							2.6	2.2
50								2.1

Pluma principal 38 m

Radio (m)	Longitud de plumín (m)					
	17	22.7	28.7	34.4	40.4	46.1
7.3	19.3					
9	18.2	15.2				
10	17.5	14.6	12.7			
11	16.7	14.0	12.2	10.1		
13	15.0	13.0	11.1	9.6	8.1	
14	14.3	12.6	10.8	9.3	7.8	6.5
16	12.9	10.5	9.9	8.7	7.3	6.2
18	10.0	9.6	9.3	8.0	6.9	5.8
20	8.2	8.8	8.5	7.5	6.4	5.5
24		7.3	7.2	6.4	5.6	4.9
30			5.4	5.2	4.7	4.2
36				4.3	3.9	3.5
42					3.2	2.9
48						2.4

Pluma principal 41 m

Radio (m)	Longitud de plumín (m)		
	22.7	25.7	28.7
8.6	13.5		
10	13.0	10.3	11.0
11	12.5	10.1	10.8
12	12.2	9.7	10.5
13	11.0	9.4	10.0
14	10.5	8.9	9.7
16	9.6	8.1	8.9
18	8.9	7.2	8.3
20	8.3	6.5	7.7
22	7.7	6.1	7.3
24	6.9	5.8	6.6
26		5.6	6.0
28		5.4	5.6
30			5.3

Capacidades de cargas indicadas en toneladas, con plumín abatible (N° 1008.xx), 32.3 t contrapeso y contrapeso central de 15 t. Estas tablas de cargas sirven únicamente como información. Para trabajos de elevación consultar las tablas de cargas de la cabina o el manual.

Tablas de cargas - plumín abatible (Nº 1309.xx)

Pluma principal con ángulo 83°

Pluma principal 17 m

Radio (m)	Longitud de plumín (m)							
	17	22.7	28.7	34.4	46.1	52.1	57.8	66.8
9.5	31.8	t	t	t	t	t	t	t
12	25.4	24.2	t	t	t	t	t	t
13	23.5	22.4	21.3	t	t	t	t	t
15	20.4	19.5	18.6	17.7	t	t	t	t
18	16.9	16.2	15.5	14.8	12.7	t	t	t
20	14.7	14.6	13.9	13.3	11.8	9.1	t	t
22		13.1	12.6	12.1	11.0	8.8	7.4	t
26		10.6	10.5	10.1	9.2	8.1	6.9	4.8
32			7.9	7.8	7.2	6.8	6.2	4.4
36				6.6	6.2	5.8	5.4	4.3
48					4.0	3.8	3.5	3.0
50						3.5	3.3	2.8
55							2.7	2.3
60							2.2	

Pluma principal 23 m

Radio (m)	Longitud de plumín (m)							
	17	22.7	28.7	34.4	46.1	52.1	57.8	66.8
10.2	27.5	t	t	t	t	t	t	t
11	25.7	t	t	t	t	t	t	t
12	23.7	22.6	t	t	t	t	t	t
14	20.5	19.5	18.6	t	t	t	t	t
16	18.0	17.2	16.4	15.7	t	t	t	t
19	15.2	14.5	13.8	13.2	11.0	t	t	t
22		12.5	11.9	11.4	10.3	8.0	t	t
24		11.5	10.9	10.4	9.4	7.7	6.5	t
26		10.4	10.0	9.5	8.6	7.5	6.3	4.4
32			7.8	7.6	6.8	6.3	5.8	4.1
38				6.0	5.4	5.0	4.7	3.8
48					3.9	3.6	3.2	2.7
55						2.8	2.5	2.0
60							2.1	

Pluma principal 29 m

Radio (m)	Longitud de plumín (m)							
	17	22.7	28.7	34.4	46.1	52.1	57.8	66.8
11	24.0	t	t	t	t	t	t	t
12	22.1	t	t	t	t	t	t	t
13	20.5	19.6	t	t	t	t	t	t
15	17.9	17.1	16.3	t	t	t	t	t
20	13.6	13.0	12.3	11.8	9.4	t	t	t
22	12.4	11.8	11.2	10.7	9.0	7.1	t	t
24		10.8	10.2	9.8	8.5	6.9	5.6	t
26		9.9	9.4	9.0	8.0	6.7	5.5	4.0
32			7.5	7.1	6.3	5.9	5.2	3.8
38				5.8	5.0	4.7	4.3	3.5
50					3.3	3.0	2.7	2.2
55						2.6	2.3	

Pluma principal 35 m

Radio (m)	Longitud de plumín (m)							
	17	22.7	28.7	34.4	46.1	52.1	57.8	66.8
11.7	20.3	t	t	t	t	t	t	t
14	17.9	15.9	t	t	t	t	t	t
16	15.8	14.7	12.6	t	t	t	t	t
17	14.9	14.1	12.2	10.1	t	t	t	t
22	11.4	11.1	9.9	8.7	6.3	5.2	t	t
24		10.1	9.3	8.2	6.0	5.1	4.2	t
28		8.1	8.2	7.5	5.5	4.7	4.0	2.9
34			6.4	6.2	5.0	4.3	3.6	2.6
38				5.4	4.5	4.0	3.4	2.5
48					3.3	3.0	2.6	2.0
50					3.1	2.8	2.4	
55						2.3		

Pluma principal 38 m

Radio (m)	Longitud de plumín (m)					
	17	22.7	28.7	34.4	40.4	46.1
12.1	17.6	t	t	t	t	t
14	16.3	13.9	t	t	t	t
16	15.0	12.9	10.8	t	t	t
18	13.6	11.6	10.1	8.7	t	t
19	12.9	11.1	9.7	8.4	6.9	t
22	10.5	9.9	8.8	7.6	6.4	5.5
28		7.7	7.5	6.5	5.6	4.9
34			6.1	5.7	5.0	4.4
40				4.5	4.4	3.8
46					3.7	3.3
50						3.0

Pluma principal 41 m

Radio (m)	Longitud de plumín (m)			
	22.7	25.7	28.7	
14.1	12.1	t	t	t
15	11.4	10.2	t	t
16	11.0	10.0	9.4	t
18	10.1	9.2	8.9	t
20	9.4	8.6	8.2	t
22	8.8	7.9	7.7	t
24	8.3	7.5	7.2	t
26	7.8	7.3	6.9	t
28	7.2	7.1	6.7	t
32		5.7	6.1	t
34			5.6	t

Capacidades de cargas indicadas en toneladas, con plumín abatible (Nº 1008.xx), 32.3 t contrapeso y contrapeso central de 15 t. Estas tablas de cargas sirven únicamente como información. Para trabajos de elevación consultar las tablas de cargas de la cabina o el manual.

Tablas de cargas - plumín abatible (N° 1309.xx)

Pluma principal con ángulo 75°

Pluma principal 17 m

Radio (m)	Longitud de plumín (m)							
	17	22.7	28.7	34.4	46.1	52.1	57.8	66.8
14.1	t	t	t	t	t	t	t	t
17	20.4							
19	16.9	16.2						
22	15.0	14.4	13.7					
28	12.4	12.3	11.8	11.3				
30		9.0	8.9	8.6	7.7			
32			8.1	8.0	7.1	6.7		
34			7.4	7.3	6.6	6.2	5.8	
36			6.8	6.7	6.1	5.7	5.3	
40				6.2	5.7	5.3	4.9	4.3
44				5.3	4.9	4.5	4.2	3.6
48					4.2	3.9	3.6	3.1
50					3.6	3.4	3.1	2.6
55					3.3	3.2	2.9	2.3

Pluma principal 23 m

Radio (m)	Longitud de plumín (m)							
	17	22.7	28.7	34.4	46.1	52.1	57.8	66.8
15.6	t	t	t	t	t	t	t	t
19	16.9							
22	13.9	13.2						
24	11.9	11.4	10.8					
28	10.7	10.4	9.8	9.4				
30		8.7	8.3	7.9	6.9			
32		7.9	7.7	7.3	6.4			
34			7.1	6.7	5.9	5.5		
36			6.5	6.3	5.5	5.1	4.7	
38			6.0	5.8	5.1	4.7	4.3	
40				5.4	4.7	4.3	4.0	3.4
48				5.0	4.4	4.0	3.7	3.1
50					3.3	3.0	2.6	2.1
55					3.1	2.7	2.4	

Pluma principal 29 m

Radio (m)	Longitud de plumín (m)							
	17	22.7	28.7	34.4	46.1	52.1	57.8	66.8
17.2	t	t	t	t	t	t	t	t
20	14.0							
24	12.0	11.4						
26	9.9	9.5	8.9					
30	9.1	8.7	8.2	7.7				
32		7.4	6.9	6.5	5.7			
36			6.4	6.1	5.2	4.7		
40			5.6	5.2	4.5	4.1	3.7	
42				4.6	3.8	3.5	3.1	2.5
44				4.3	3.6	3.2	2.8	2.3
48					3.3	2.9	2.6	2.1
50					2.8	2.5	2.2	

Pluma principal 35 m

Radio (m)	Longitud de plumín (m)							
	17	22.7	28.7	34.4	46.1	52.1	57.8	
18.7	t	t	t	t	t	t	t	
22	11.4							
24	9.9	9.4						
26	9.0	8.5	8.0					
28	8.3	7.8	7.3					
32		7.2	6.7	6.3				
34		6.2	5.8	5.4	4.6			
36			5.4	5.0	4.2	3.8		
38			5.0	4.6	3.9	3.5	3.1	
44			4.7	4.3	3.6	3.2	2.8	
48				3.5	2.8	2.4	2.1	
50					2.4	2.0		

Pluma principal 38 m

Radio (m)	Longitud de plumín (m)							
	17	22.7	28.7	34.4	40.4	46.1		
19.5	t	t	t	t	t	t		
22	10.4							
26	9.3	8.7						
28	7.8	7.4	6.9					
30	7.2	6.8	6.3	5.9				
32		6.3	5.8	5.4	5.0			
34		5.8	5.4	5.0	4.6	4.2		
40		5.4	5.0	4.6	4.2	3.9		
44			4.1	3.7	3.3	3.0		
48				3.2	2.9	2.5		
50					2.5	2.1		

Pluma principal 41 m

Radio (m)	Longitud de plumín (m)							
	22.7	25.7	28.7					
22.7	t	t	t					
24	7.9							
26	7.6	7.1						
28	6.9	6.7	6.4					
30	6.4	6.1	5.9					
32	5.9	5.7	5.4					
34	5.5	5.2	5.0					
36	5.1	4.9	4.7					
38		4.5	4.3					
40			4.0					

Capacidades de cargas indicadas en toneladas, con plumín abatible (N° 1008.xx), 32.3 t contrapeso y contrapeso central de 15 t. Estas tablas de cargas sirven únicamente como información. Para trabajos de elevación consultar las tablas de cargas de la cabina o el manual.

Tablas de cargas - plumín abatible (N° 1309.xx)

Pluma principal con ángulo 65°

Pluma principal 17 m

Radio (m)	Longitud de plumín (m)							
	17	22.7	28.7	34.4	46.1	52.1	57.8	66.8
19.5	t	t	t	t	t	t	t	t
24	13.5	10.3						
26	10.4	9.3						
28	9.3	8.4	8.2					
30		7.6	7.5	7.2				
36			5.8	5.6				
38				5.2	4.6			
40				4.8	4.3	3.9		
42				4.4	4.0	3.6		
44					3.7	3.4	3.0	
48					3.2	2.9	2.6	2.0
50					2.9	2.7	2.4	
55					2.2			

Pluma principal 23 m

Radio (m)	Longitud de plumín (m)							
	17	22.7	28.7	34.4	46.1	52.1	57.8	
22	t	t	t	t	t	t	t	
26	10.5	8.4						
28	8.7	7.7						
30	7.9	7.1	6.7					
34		5.9	5.7	5.4				
38			4.9	4.6				
40				4.3	3.6			
42				4.0	3.3			
44				3.7	3.1	2.7		
46					2.8	2.5	2.1	
48					2.6	2.3		
50					2.4	2.1		
55					2.0			

Pluma principal 29 m

Radio (m)	Longitud de plumín (m)					
	17	22.7	28.7	34.4	46.1	
24.5	t	t	t	t	t	
28	8.1	6.6				
30	7.1	6.1				
32	6.5	5.7	5.2			
36		4.9	4.5	4.1		
42			3.6	3.3	2.6	
44				3.1	2.4	
46				2.9	2.2	
48				2.7		

Pluma principal 35 m

Radio (m)	Longitud de plumín (m)				
	17	22.7	28.7	34.4	
27.1	t	t	t	t	
32	6.2	4.8			
34	5.1	4.4	4.0		
38		3.8	3.4	3.0	
40			3.2	2.8	
42			2.9	2.6	
44			2.7	2.4	
46				2.2	
48				2.0	

Pluma principal 38 m

Radio (m)	Longitud de plumín (m)				
	17	22.7	28.7	34.4	
28.3	t	t	t	t	
32	5.3	4.3			
34	4.7	4.0			
36	4.3	3.7	3.2		
40		3.1	2.8	2.4	
44			2.3	2.0	
46			2.1		

Pluma principal 41 m

Radio (m)	Longitud de plumín (m)			
	22.7	25.7	28.7	
32.9	t	t	t	
34	3.6			
36	3.5			
38	3.2	3.0		
40	2.9	2.7	2.5	
42	2.7	2.5	2.3	
44		2.3	2.1	
		2.1		

Capacidades de cargas indicadas en toneladas, con plumín abatible (N° 1008.xx), 32.3 t contrapeso y contrapeso central de 15 t. Estas tablas de cargas sirven únicamente como información. Para trabajos de elevación consultar las tablas de cargas de la cabina o el manual.

Tablas de cargas - plumín abatible (N° 1309.xx)

Pluma principal con ángulo 45°

Pluma principal 17 m

Radio (m)	Longitud de plumín (m)							
	17	22.7	28.7	34.4				
t	t	t	t					
28.4	7.1							
30	6.7							
34		5.5						
36		5.0						
38			4.4					
42			3.8					
44				3.3				
46				3.1				

Pluma principal 23 m

Radio (m)	Longitud de plumín (m)							
	17	22.7	28.7	34.4				
t	t	t	t					
32.6	5.0							
34	4.8							
38		3.9						
40		3.6						
44			2.8					
46			2.6					
48				2.2				

Pluma principal 29 m

Radio (m)	Longitud de plumín (m)						
	17	22.7					
t	t	t					
36.9	3.3						
38	3.2						
42		2.5					
44		2.3					

Capacidades de cargas indicadas en toneladas, con plumín abatible (N° 1008.xx), 32.3 t contrapeso y contrapeso central de 15 t. Estas tablas de cargas sirven únicamente como información. Para trabajos de elevación consultar las tablas de cargas de la cabina o el manual.

Radio de trabajo - plumín fijo (N° 0806.xx) 15° y 30°

Pluma principal con ángulo 88°- 30°

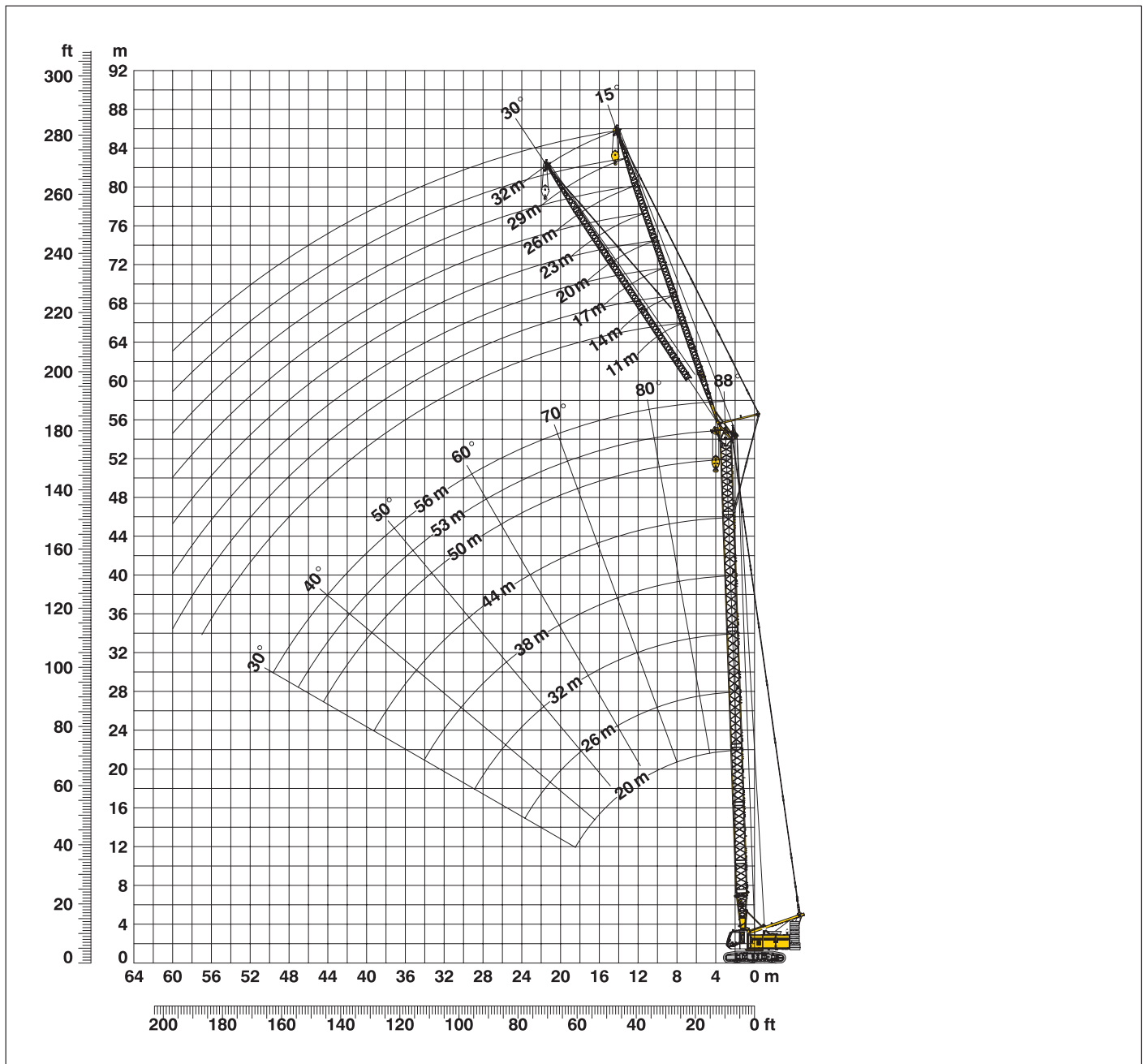

Configuración de pluma principal (20 m - 56 m) – vea tabla 1 en la pagina 12

Configuración del plumín fijo (11 m - 32 m)

	Longitud	Número de tramos de plumín fijo							
Pie plumín fijo	5.5 m	1	1	1	1	1	1	1	1
Tramo plumín fijo	3.0 m		1		1		1		1
Tramo plumín fijo	6.0 m	0	0	1	1	2	2	3	3
Cabeza plumín fijo	5.5 m	1	1	1	1	1	1	1	1
Longitud plumín fijo (m)		11	14	17	20	23	26	29	32

Tablas de cargas - plumín fijo (N° 0806.xx)

Con ángulo 15°

Pluma principal 20 m

Radio (m)	Longitud de plumín (m)			
	11	20	26	32
4.8	24.0			
9	23.0	12.6		
11	21.6	10.9	6.9	
14	19.8	9.9	6.3	4.1
16	18.7	9.3	6.0	3.9
18	16.0	8.8	5.7	3.7
20	13.9	8.3	5.4	3.6
22	12.2	7.9	5.1	3.5
24	10.9	7.6	4.9	3.3
26	9.7	7.2	4.7	3.2
28	8.7	7.0	4.5	3.1
30	7.9	6.7	4.3	3.0
38		5.8	3.8	2.7
44			3.7	2.5
50				2.5

Pluma principal 26 m

Radio (m)	Longitud de plumín (m)			
	11	20	26	32
5.1	24.0			
9	22.3	12.1		
11	21.1	10.6	6.7	
14	19.2	9.7	6.2	4.0
16	17.8	9.2	5.9	3.9
18	15.6	8.8	5.6	3.7
20	13.6	8.3	5.3	3.6
22	12.0	7.9	5.1	3.5
24	10.6	7.6	4.9	3.3
26	9.4	7.3	4.7	3.2
30	7.6	6.7	4.4	3.0
34	6.2	6.4	4.1	2.9
44		4.3	3.6	2.5
50			3.5	2.4
55				2.4

Pluma principal 32 m

Radio (m)	Longitud de plumín (m)			
	11	20	26	32
5.3	22.8			
9	20.7	10.4		
12	19.1	9.8	6.3	
14	18.0	9.3	6.0	3.9
16	16.9	8.9	5.7	3.8
18	14.9	8.5	5.5	3.7
20	13.2	8.1	5.2	3.5
22	11.8	7.8	5.0	3.4
26	9.2	7.2	4.6	3.2
32	6.7	6.4	4.2	2.9
36	5.5	5.9	4.0	2.8
40	4.5	4.9	3.8	2.6
48		3.4	3.5	2.5
55			2.7	2.4
60				2.3

Pluma principal 38 m

Radio (m)	Longitud de plumín (m)			
	11	20	26	32
5.5	20.5			
9	19.0	9.8		
12	17.3	9.3	6.0	
14	16.3	8.9	5.8	3.8
16	15.4	8.5	5.6	3.7
20	12.4	7.8	5.1	3.5
24	10.0	7.3	4.7	3.2
28	8.0	6.7	4.4	3.1
32	6.4	6.2	4.2	2.9
36	5.2	5.7	3.9	2.8
40	4.2	4.7	3.7	2.6
44	3.5	3.9	3.6	2.5
50		2.9	3.1	2.4
55			2.4	2.3
60				2.0

Pluma principal 44 m

Radio (m)	Longitud de plumín (m)			
	11	20	26	32
5.7	17.4			
10	15.7	8.8		
11	15.3	8.7		
12	14.9	8.5	5.6	
13	14.5	8.4	5.6	
14	14.1	8.2	5.5	3.7
18	12.6	7.6	5.1	3.5
22	10.5	7.0	4.7	3.3
26	8.5	6.4	4.4	3.1
30	6.9	5.9	4.1	2.9
34	5.6	5.4	3.9	2.8
38	4.5	4.9	3.7	2.6
42	3.6	4.0	3.6	2.5
46	2.9	3.3	3.4	2.4
50	2.3	2.7	2.9	2.3
55		2.0	2.2	2.3

Pluma principal 50 m

Radio (m)	Longitud de plumín (m)			
	11	20	26	32
5.9	14.7			
10	13.4	8.0		
12	12.6	7.8	5.2	
15	11.1	7.3	5.0	3.5
16	10.8	7.1	4.9	3.4
18	10.1	6.8	4.8	3.3
22	9.0	6.2	4.5	3.1
26	7.8	5.7	4.2	3.0
30	6.4	5.2	4.0	2.8
34	5.2	4.7	3.7	2.7
38	4.2	4.2	3.5	2.5
42	3.4	3.7	3.2	2.5
46	2.6	3.0	3.0	2.4
48	2.3	2.7	2.8	2.3
50	2.0	2.4	2.6	2.3
55				2.0

Pluma principal 53 m

Radio (m)	Longitud de plumín (m)			
	11	20	26	32
6	13.4			
11	11.6	7.4		
12	11.4	7.3	5.0	
15	10.5	6.9	4.8	3.4
18	9.6	6.5	4.6	3.3
22	8.6	5.9	4.3	3.1
26	7.6	5.4	4.1	2.9
30	6.1	5.0	3.8	2.8
34	4.9	4.5	3.6	2.6
38	4.0	4.2	3.4	2.5
40	3.5	3.8	3.3	2.5
42	3.2	3.5	3.2	2.4
44	2.8	3.1	3.1	2.4
46	2.5	2.8	2.9	2.3
48	2.2	2.5	2.6	2.3
50		2.2	2.4	2.2

Pluma principal 56 m

Radio (m)	Longitud de plumín (m)			
	11	14	20	23
6.1	10.6			
8	10.6	9.1		
10	10.3	9.1	6.6	
11	10.0	8.9	6.6	5.6
12	9.8	8.7	6.5	5.5
14	9.2	8.2	6.3	5.4
18	8.1	7.3	5.8	5.1
22	7.2	6.5	5.2	4.7
26	6.3	5.8	4.8	4.3
30	5.6	5.1	4.3	4.0
34	4.7	4.6	3.9	3.6
38	3.8	3.9	3.6	3.3
42	3.0	3.1	3.2	3.0
46	2.3	2.4	2.6	2.7
48	2.0	2.1	2.3	2.4
50			2.1	2.2

Capacidades de cargas indicadas en toneladas, con plumín fijo (N° 0806.xx), 32.3 t contrapeso y contrapeso central de 15 t. Estas tablas de cargas sirven únicamente como información. Para trabajos de elevación consultar las tablas de cargas de la cabina o el manual.

Tablas de cargas - plumín fijo (N° 0806.xx)

Con ángulo 30°

Pluma principal 20 m

Radio (m)	Longitud de plumín (m)			
	11	20	26	32
7.5	t	t	t	t
13	21.7	9.0		
17	16.7	8.2	5.2	
22	12.4	7.4	4.7	3.2
24	11.0	7.0	4.5	3.1
26	9.8	6.8	4.4	3.0
28	8.8	6.6	4.2	3.0
30	7.9	6.4	4.1	2.9
34		6.2	3.9	2.7
36		6.1	3.8	2.7
38		5.9	3.8	2.6
42			3.7	2.5
44			3.7	2.5
48				2.5
50				2.6

Pluma principal 26 m

Radio (m)	Longitud de plumín (m)			
	11	20	26	32
7.7	t	t	t	t
14	20.6	8.6		
17	16.7	8.1	5.1	
22	12.2	7.3	4.7	3.2
24	10.8	7.1	4.5	3.1
26	9.6	6.8	4.4	3.0
28	8.6	6.6	4.3	2.9
30	7.8	6.5	4.1	2.9
32	7.0	6.3	4.0	2.8
34	6.3	6.2	3.9	2.7
38		5.8	3.8	2.6
44		4.4	3.6	2.5
48			3.5	2.5
50			3.4	2.5
55				2.6

Pluma principal 32 m

Radio (m)	Longitud de plumín (m)			
	11	20	26	32
7.9	t	t	t	t
14	19.1	8.3		
17	14.8	7.8	4.9	
22	11.9	7.2	4.6	3.1
26	9.5	6.6	4.3	3.0
28	8.5	6.4	4.2	2.9
30	7.6	6.2	4.1	2.9
32	6.8	5.9	4.0	2.8
34	6.2	5.7	3.9	2.7
36	5.6	5.5	3.8	2.7
38	5.1	5.4	3.8	2.6
40	4.6	5.1	3.7	2.6
50		3.2	3.5	2.4
55			2.7	2.5
60				2.3

Pluma principal 38 m

Radio (m)	Longitud de plumín (m)			
	11	20	26	32
8.1	t	t	t	t
14	17.1	7.8		
18	13.4	7.4	4.7	
22	11.5	6.9	4.5	3.1
26	9.3	6.4	4.3	2.9
30	7.4	5.9	4.1	2.8
34	6.0	5.5	3.9	2.7
36	5.4	5.4	3.8	2.7
38	4.8	5.2	3.7	2.6
40	4.4	4.9	3.7	2.6
42	3.9	4.5	3.6	2.5
44	3.5	4.1	3.5	2.5
46	3.2	3.7	3.5	2.4
55		2.3	2.6	2.4
60				2.2

Pluma principal 44 m

Radio (m)	Longitud de plumín (m)			
	11	20	26	32
8.3	t	t	t	t
14	14.6	7.2		
18	11.2	6.9	4.5	
22	10.1	6.3	4.3	3.0
26	8.8	5.9	4.1	2.9
30	7.1	5.5	3.9	2.8
34	5.8	5.1	3.8	2.6
38	4.7	4.7	3.6	2.6
42	3.8	4.3	3.4	2.5
44	3.4	3.9	3.4	2.4
46	3.0	3.5	3.3	2.4
48	2.7	3.2	3.2	2.4
50	2.4	2.8	3.1	2.4
55		2.1	2.4	2.3
60				2.0

Pluma principal 50 m

Radio (m)	Longitud de plumín (m)			
	11	20	26	32
8.5	t	t	t	t
14	12.1	6.4		
18	9.4	6.1	4.3	
22	8.4	5.6	4.1	2.9
26	7.4	5.2	3.9	2.8
30	6.6	4.8	3.7	2.7
34	5.4	4.4	3.5	2.6
38	4.4	4.0	3.3	2.5
40	3.9	3.9	3.2	2.4
42	3.5	3.7	3.1	2.4
44	3.1	3.5	3.0	2.3
46	2.8	3.3	2.9	2.3
48	2.4	2.9	2.8	2.3
50	2.1	2.6	2.7	2.2
55			2.2	2.1

Pluma principal 53 m

Radio (m)	Longitud de plumín (m)			
	11	20	26	32
8.6	t	t	t	t
15	10.7	6.0		
18	8.8	5.8	4.1	
22	7.9	5.4	4.0	2.8
26	7.1	4.9	3.9	2.7
30	6.4	4.6	3.6	2.6
34	5.2	4.2	3.4	2.5
38	4.2	3.9	3.2	2.4
40	3.7	3.8	3.1	2.4
42	3.3	3.6	3.0	2.4
44	3.0	3.4	2.9	2.3
46	2.6	3.1	2.8	2.3
48	2.3	2.7	2.8	2.2
50	2.0	2.4	2.7	2.2
55			2.0	2.1

Pluma principal 56 m

Radio (m)	Longitud de plumín (m)			
	11	14	20	23
8.7	t	t	t	t
11	9.1	7.6		
15	8.2	7.2	5.3	
17	7.8	6.9	5.3	4.5
19	7.3	6.6	5.1	4.5
22	6.7	6.0	4.8	4.3
26	6.0	5.5	4.4	4.0
30	5.3	4.9	4.1	3.7
34	4.8	4.5	3.7	3.4
38	4.0	4.0	3.4	3.1
42	3.2	3.3	3.1	2.9
44	2.8	3.0	3.0	2.8
46	2.5	2.6	2.8	2.6
48	2.2	2.3	2.6	2.5
50		2.0	2.3	2.4

Capacidades de cargas indicadas en toneladas, con plumín fijo (N° 0806.xx), 32.3 t contrapeso y contrapeso central de 15 t. Estas tablas de cargas sirven únicamente como información. Para trabajos de elevación consultar las tablas de cargas de la cabina o el manual.

