Freshness to the fullest

Discover our freestanding and
fully integrated appliances.

LIEBHERR

Refrigeration and freezing





CBNes 6256

Global success: The Liebherr Group.

Liebherr is a third-generation, family-owned company founded in 1949 by Hans Liebherr with his ground-breaking invention of the world's first mobile tower crane.

With over 70 years of success, Liebherr is known as a pioneer in high-quality, breakthrough innovations and countless cutting-edge technologies in numerous industries. One of the world's largest manufacturers of construction machinery, Liebherr has expanded its broadly diversified portfolio to 13 product segments including earthmoving, deep foundation machines, mobile and crawler cranes, tower cranes, concrete technology, material handling technology, mining, maritime cranes, aerospace and transportation systems, gear technology and automation systems, components, hotel, and refrigeration and freezing. The company currently employs about 48,000 people in more than 140 companies in over 50 countries worldwide.



Mobile cranes



Aerospace



Earthmoving



Crawler cranes



Refrigeration and freezing



Liebherr-Hausgeräte GmbH, Germany

Liebherr-Hausgeräte – Specialists in refrigeration and freezing.

Liebherr-Hausgeräte covers the full range of refrigeration and freezing for domestic and commercial use. Headquartered in Germany, Liebherr-Hausgeräte has an impressive range of more than 3,000 products in its portfolio.



Portrait of the Liebherr Group

Before we think about fridges, we think about you.

Fridges are supposed to cool. But what else should modern appliances be capable of today? How can they better meet customer needs? How can their design be more efficient, intuitive and modern?

We think about all these questions every day, because for us a fridge is not just an appliance. Instead, it should be a partner who supports us where it can ... who thinks in harmony with us, takes on tasks and makes work easier. In order to achieve this, we are constantly developing our appliances. Because the smarter and more helpful they are, the more time you have for all the other important things in life.

Achieving the highest quality is our standard.

We have been manufacturing high-quality fridges and freezers and selling them around the world since 1954. Yet at heart we are still a family business and have our roots firmly based in Germany. We continue to develop our products here. German engineering – from an enduring connection with our founder and in the knowledge that engineering expertise has been pooled here for generations.

Built to last.

You can experience our quality standards in the smallest of details. For example, before a door hinge is approved by us, it must pass through at least 100,000 opening cycles. This corresponds to a usage period of more than 15 years. We also test all other functional parts to ensure that they can last just as long. We have leveling bars to ensure that your fully integrated appliance works perfectly over this long period and stands firmly in place, even when the wood in the kitchen unit settles. They harmoniously compensate for any unevenness between the floor and the appliance, so that the fridge door always closes tightly. It may sound simple, but this is crucial for avoiding condensation and increased energy consumption.

And if, contrary to expectations, a small detail no longer meets your requirements, you or your expert service partner can usually correct it quickly, because all of our appliances are extremely easy to repair. We keep all essential spare parts in stock for well over 10 years. This saves you money for minor repairs or the purchase of a new appliance – and it is also sustainable.

We don't just say it. We also guarantee it.

During production, we take a very close look at all of our fridge components and test them far more thoroughly and more often than required by law – right up until the packaging stage. Only then may our appliances take a little rest. All our production sites are certified according to international ISO 9001 standard for quality and ISO 14001 standard for environmental management. Therefore it is wholly natural for us to guarantee you that for at least two years our products will be free of material and manufacturing defects and are particularly easy to install.

One thing is certain in any case: Your Liebherr will be reliable companion for a very long time.

 German Engineering



Quality video - Before we think about fridges, we think about you



Taste that stands the test of time: Freshness is a question of technology.

Storing groceries in ideal climatic conditions not only ensures extra-long freshness and storage time, it also makes a substantial contribution to avoiding food waste. With our appliances this is possible – thanks to the perfect combination of integrated freshness technologies.

DuoCooling. No drying out.

Our basic technology in all fridge-freezers is called DuoCooling. Thanks to two completely separate refrigeration circuits, it ensures that there is no exchange of air between the fridge and freezer compartments. The food neither dries out nor are odours transferred – so that only the Camembert smells and tastes like Camembert.



EasyFresh. Ideal for fruit and vegetables.

The freshness guarantee in your Liebherr fridge. Unpacked fruit and vegetables feel right at home here. At the same temperature as in the fridge compartment and air-tight, lettuce, for example, remains crisp and fresh even after 10 days.



BioFresh. Our all-rounder.

With our patented BioFresh technology, food is stored at a much cooler temperature than in the rest of the appliance. At temperatures just over 0 °C and with perfect humidity, BioFresh offers the ideal storage conditions. The air-tight Fruit & Vegetable safe is the ideal environment for fresh produce. Meat, fish and dairy products are in good hands in the Meat & Dairy safe.

BioFresh Professional. Refrigerate like the professionals.

A special innovation can be found in the BioFresh Professional and the brand new HydroBreeze feature. Every time the door is opened and after every 90 minutes, a fresh, cold mist is produced, covering fruits and vegetables like a balm to ensure crisp freshness and giving them a nice wow effect.

Fresh. Sustainable. Healthy.

The storage climate: We could write so much about it. To put it briefly, there are three main reasons that motivate us to keep perfecting it. First: An ideal climate contributes to keeping your food fresh for longer. You can enjoy it fresh for longer. Second: This prevents unnecessary food waste and means you have to go shopping less frequently. Three: Optimal storage helps to protect vitamins and nutrients. And this contributes to a healthy diet.



BioFresh - the perfect environment for
your food



Timeless and elegant. Design for every kitchen.

Liebherr appliances are designed to inspire awe and integrate seamlessly into your kitchen. Multiple size configurations, installation options, and choice of stainless steel or personalized finishes allow for perfect integration into your dream kitchen.

Design meets functionality.

Puristic and timeless on the one hand. Elegant and exclusive on the other. The Liebherr design language blends design and functionality. The high quality glass and stainless steel components are impressive. The precise craftsmanship, an eye for detail, and the harmonious combination of materials, shapes and colours create an aesthetically pleasing end product.



Our LEDs provide a pleasant, bright light tone that makes your food look even more appetizing. As they have a very low heat generation, everything stays cool and fresh.



Perfectly balanced: a powerful, complete package.

A good fridge is a real all-rounder: In addition to low power consumption and low noise levels, it should also offer plenty of space for food and have power reserves for when they are needed. For this reason we don't pay attention to just one factor, instead we have all usage situations in mind at once. The result: our appliances offer a balanced, perfectly coordinated complete package of energy efficiency, volume, noise level and cooling performance. So all good things come in fours for us.



Efficiency

Liebherr appliances occupy top positions in efficiency rankings. In this way, they protect the precious resources of our environment and, thanks to low electricity costs, your wallet too.

Volume

We have the perfect appliance for all family sizes, lifestyles and niche heights. From extra-large drawers to the smallest details, we make sure that no liter of volume goes to waste. For example, through space-saving lighting solutions recessed into the housing.

Noise level

Kitchen and living spaces are merging more and more in modern home design concepts. This underlines the importance of particularly quiet fridges. Our product range therefore offers a wide selection of extremely quiet appliances. Some even achieve the ultra-quiet level of 29 dB.

Refrigeration

Intelligent sensor technology constantly adapts the cooling performance to the current use – our appliances are very energy-efficient and economical in everyday use. At the same time, they offer considerable power reserves. For example, to cool a larger amount of food after the weekly shop and they are especially good for spontaneous visits. Drinks can be brought to a pleasant drinking temperature extremely quickly at the touch of a button.



Sustainability inside.

With a Liebherr, you are not only doing something good for your food, but also for the environment. Because we are constantly working on reducing the consumption and electricity costs of the appliances even further – while maintaining their excellent performance.

For example, we test all functional parts for a service life of 15 years. And just in case, we guarantee a long availability of spare parts. This means that you can enjoy a Liebherr for many years – and at the same time take care of your ecological footprint: because a long service life significantly reduces the consumption of energy and resources.



Freestanding appliances



SBSes 8474



Bio Fresh Plus

Unique features.



IceMaker

Are there any ice cubes left? An IceMaker means you never have to ask. With the IceMaker with fixed water connection, the water comes directly from the tap. The MaxIce function allows you to produce up to 1.5 kg of ice cubes a day. The ice cube separator helps to divide the drawer into any size you want – for example, ice cubes on the left, ice cream on the right – or just for ice cubes.



SoftSystem

From breakfast to a midnight snack – a fridge needs to be open and closed on many occasions. And your Liebherr makes this a lot of fun. With the SoftSystem, your fridge door closes softly and safely, and in a way which is pleasantly quiet and light. Bottles stored in the inside door remain securely in place – nothing rattles or wobbles.



BioFresh

BioFresh provides the perfect climate – for long-lasting food storage. When stored at just over 0°C and at the ideal humidity level, fruit, vegetables, meat and fish all retain their nutritious vitamins for longer.



SmartSteel

A specially treated stainless steel finish that significantly reduces the visibility of fingerprints, making it very easy to clean. Maintain this beautiful surface simply by wiping it with a soft, damp cloth.



Touch-Display

The elegant MagicEye control system with the innovative, user-friendly Touch-electronic feature ensures that the temperature in the fridge compartment and freezer compartment is kept to the selected temperature. All the functions can be simply and conveniently operated at the touch of a finger.



Sturdy handle design

The sturdy handle with its refined, premium-quality appearance and an integrated opening mechanism ensures easy and effortless opening of the door. The handle perfectly complements the HardLine door design, and is made from anodised aluminium or white plastic. It can be easily repositioned if the hinge side of the door is changed.



More about
PRIME Lever handle

Masterpiece in Innovative Freshness Technology.

Timelessly elegant with a full stainless steel body, our award-winning BluPerformance SBSes 8486 Side-by-Side fridge-freezer with six different climate zones boasts an array of innovative solutions.

The dual-zone wine compartment allows you to store two different types of wine at their respective desired temperatures, ranging from +5 °C to +20 °C. The NoFrost freezer with automatic IceMaker provides professional freezing technology for long-term freshness while a spacious refrigerator provides an extended shelf life for fresh groceries.

The BioFresh-Plus compartment includes a versatile Fish & Seafood safe and offers an adjustable temperature range of 0 °C and -2 °C to provide even more storage flexibility for a wide array of meat and produce.

Technical data see page 84.

- Bio Fresh Plus
- No Frost
- Ice Maker
- Wine
- Soft System
- Soft-Telescopic
- Smart Steel
- Vario Space

SBSes 8486



The big, cool combination.

The **SBSes 8474** Side-by-Side fridge-freezer from the energy efficient BluPerformance series combines ample fridge storage with perfect cooling performance for long-lasting freshness.

This Side-by-Side appliance can be precisely controlled via its intuitive touch temperature display.

Get your daily dose of freshness with Liebherr's patented BioFresh technology which allows each drawer to be adjusted individually to provide the ideal humidity for different types of food. And thanks to the innovative NoFrost technology, this appliance never has to be defrosted.

Its stunning SmartSteel exterior in combination with high-quality materials and exquisite workmanship make this model the highlight of your kitchen.

Technical data see page 85.

Bio
Fresh

No
Frost

Ice
Maker

Soft
System

Soft-
Telescopic

Smart
Steel

Vario
Space

SBSes 8474

A spacious refrigerator and freezer all in one.

The **SBSef 7242** Side-by-Side fridge-freezer brings together high-quality components and meticulous workmanship to guarantee food freshness and user-friendliness.

The freezer offers up to eight drawers to give an extra-large capacity for freezing your food. The transparent fruit and vegetable drawers in the refrigerator provide a clear view of the stored food and slide out effortlessly on the roller system.

The stainless doors with special SmartSteel coating makes this appliance easier to clean.

Technical data see page 86.

No Frost

Smart Steel

Super Cool

Super Frost

Vario Space

SBSef 7242

The innovative food storage centre.

The food storage centre **CBNes 6256** with its elegant Frenchdoor concept is a focal point in any kitchen, open or closed.

The interior presents a host of innovative ideas. Take the LED interior light and the automatic IceMaker with fixed water connection in the freezer compartment, for example. In the two BioFresh drawers, fruits, vegetables, meat and dairy products stay fresh for significantly longer at around 0 °C.

Accurate and independent temperature control of the fridge and freezer compartments is ensured by DuoCooling: two separately adjustable cooling circuits. There is no air exchange between the refrigerator and freezer compartment, so that odours cannot be transferred and the stored food is prevented from drying out.

Technical data see page 87.



- Bio Fresh
- No Frost
- Duo Cooling
- Ice Maker
- Telescopic Rails
- Super Cool
- Super Frost

CBNes 6256





Practicality and elegance for your kitchen.

The **CNPef 4516** Bottom-mount freezer is the practical and elegant solution for small footprint installations such as studio apartments.

Thanks to VarioSpace, the drawers and safety glass shelves can be removed to conveniently create extra storage space for larger frozen goods.

Independent temperature control of the fridge and freezer compartments is facilitated by DuoCooling, two separately adjustable cooling circuits to prevent air exchange between the two compartments. This eliminates odour transfers and prevents food from drying out.

For larger households, double your food storage capacity by installing two units together.

Technical data see page 88.

No Frost

Duo Cooling

Smart Steel

Super Cool

Super Frost

Vario Space

CNPef 4516

An optical highlight in BlackSteel.

The spacious **SKBbs 4350** fridge has BioFresh technology to ensure a longer shelf life for fruit, vegetables, fish, meat and dairy products.

Through its advanced technology the temperature is accurately kept at just above 0 °C. The BioFresh drawers extend on smooth running telescopic rails.

The elegant, precise MagicEye control with the innovative touch control concept ensures that the selected temperatures are maintained to the exact degree.

All the functions can be simply and conveniently operated at the touch of a finger on the control panel.

Technical data see page 89.

Bio
Fresh

Soft
System

Soft-
Telescopic

Super
Cool

SKBbs 4350

The stylish answer to freshness.

The sophisticated **SICBN 3366** fridge-freezer is the perfect built-in appliance for small spaces, galley kitchens, or apartment living. Our door-on-door technology allows custom paneling to be affixed directly onto the appliance door, ensuring that the cabinet and refrigerator door open as one.

Liebherr's automatic IceMaker with fixed water connection produces a constant supply of ice cubes.

Though slim in stature, this appliance is full of innovative features such as BioFresh technology. While the DrySafe is perfect for meat, fish, and dairy products, the Fruit & Vegetable-Safe is great at retaining moisture in fruits and vegetables. Our FlexSystem helps to ensure neat separation and clear sorting.

The **SICBN 3366** is also available without IceMaker as **SICBN 3356**.

Technical data both models see page 92.

Bio
Fresh

No
Frost

Duo
Cooling

Ice
Maker

Soft
System

Soft-
Telescopic

Vario
Space

SICBN 3366

Elegant refrigeration technology in perfection.

The **SICN 3314** blends in beautifully with any kitchen cabinetry, providing diverse design options to fit your dream kitchen.

Liebherr's door-on-door technology allows for custom paneling to be affixed directly onto the appliance door, ensuring that the cabinet and the refrigerator door open as one, allowing for additional design options and easy installation.

The **SICN 3314** includes a BioCool drawer which regulates humidity via a slider control to help keep fruits and vegetables fresher for longer.

Technical data see page 93.

- Bio Cool
- No Frost
- Duo Cooling
- Super Cool
- Super Frost
- Vario Space

SICN 3314

The best sides of your kitchen.

Seamlessly tucked away behind your cabinetry, the **SIGN 3576** and **SIKB 3550** Side-by-Side combination is your kitchen's best kept secret. Enjoy ultimate freshness with **SIKB 3550** Fridge!

Liebherr's patented BioFresh technology keeps meat, fish, and dairy fresh in the DrySafe drawer while high humidity in the Fruit & Vegetable-Safe efficiently retains natural moisture in unpackaged fruits and vegetables.

With our practical FlexSystem and flexible bottle racks, you can get things organised while maximising interior space.

The **SIGN 3576** NoFrost Freezer comes with eight generous FrostSafe drawers on telescopic rails that can be easily removed for added flexibility. And thanks to the built-in IceMaker you will always be able to have cold drinks on hand for every occasion.

SoftSystem facilitates the gentle closing of both appliance doors even when the fridge door shelves are fully-loaded.

Technical data both models see page 94.

SIGN 3576 | SIKB 3550

Bio Fresh

No Frost

Soft System

Soft-Telescopic

LED

Ice Maker

Super Cool

Super Frost

Vario Space



Fresh on the inside, sleek on the outside.

Behold the **ECBN 6256** fridge-freezer with its magnificent French doors. Highlighted by BioFresh technology to provide targeted humidity for specific foods, this is your answer to style and freshness.

Our innovative DuoCooling system eliminates any odour transfers between the fridge and freezer compartments, while the plumb-in IceMaker provides an ample supply of perfect ice cubes.

Opt for our stainless steel panels and handles for that extra touch of elegance!

Technical data see page 95.

Bio
Fresh

No
Frost

Duo
Cooling

Ice
Maker

Soft
System

Telescopic
Rails

Super
Cool

Super
Frost

ECBN 6256

Convenience at your fingertips.

Our space-saving undercounter appliances are the practical choice for compact living spaces. The **SUIK 1510** Undercounter Fridge is great for fresh produce with height-adjustable glass shelves to ensure maximise storage flexibility.

The perfect companion for this undercounter fridge is the **SUIG 1514** Undercounter Freezer with SmartFrost technology, allowing food to freeze faster and reducing ice build-up to make defrosting simpler and quicker.

Both models are equipped with innovative SoftSystem technology which ensures that the appliance door closes gently and automatically from an opening angle of approximately 30°. No ventilation grill is needed in your worktop as airflow enters and exits from the front of both undercounter models.

Technical data both models see page 97.

Soft
System

Smart
Frost

Super
Cool

Super
Frost

Vario
Space

SUIG 1514 | SUIK 1510

Wine cabinets



WTes 5872

The ideal storage temperature for wine.

The ideal long term storage temperature for wine is between +10 °C and +12 °C. It is critical that the temperature is kept as constant as possible because this is the only way that a wine's natural harmony will be preserved.

As the temperature rises, the wine molecules kinetic energy increases and this accelerates the aging process causing the wine to deteriorate. Consequently, storage temperatures of between +10 °C and +12 °C are recommended for storing wine over prolonged periods. Maintaining a constant temperature is most important, as fluctuations during storage will impair the quality of the wine.

Furthermore, the temperature at which a wine is consumed also plays a crucial role in how it tastes. Red wines should be served at a warmer temperature than white wines because they contain more tannins (polyphenols). Tannins react with oxygen more quickly at higher temperatures. This is what happens in the process of allowing a wine to breathe, when the full aroma and taste are only achieved once the wine has combined with oxygen. The length of time for which a wine should breathe depends on its variety and quality. Barolo, Rioja, Burgundy and Bordeaux each take a different amount of time to develop. In general, the longer a wine matured in the barrel, the more likely it is to need a longer breathing time for full enjoyment.

2 - 3 temperature zones

+ 5 °C to + 20 °C

+ 5 °C to + 20 °C

+ 5 °C to + 20 °C

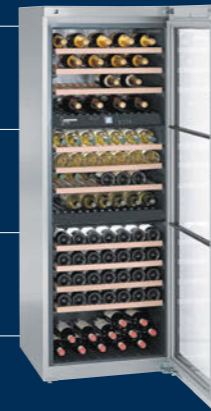

The **Vinidor range** offers ultimate flexibility and combines the advantages of both wine storage cabinets and multi-temperature wine cabinets in a single appliance. Appliances in the range come with either two or three temperature zones, which can be set independently to the required temperature between +5 °C and +20 °C. Accordingly, an appliance with three temperature zones can simultaneously store red wine, white wine, and champagne all at their optimum serving temperature. Vinidor appliances also offer the perfect climate for long-term wine storage. The varying sizes of the temperature zones, together with the fully adjustable temperature controls, make these appliances suitable for just about any collection of wines.

Temperature range

+ 5 °C to + 20 °C



Wine storage cabinets offer similar conditions to a wine cellar. They are therefore an ideal choice for both long-term storage and storage of large wine stocks, always achieving the perfect serving temperature. The temperature can be adjusted from +5 °C to +20 °C as appropriate, and is both even and constant throughout the entire appliance interior.

Bordeaux bottles capacity (0,75 l)
as per norm NF H 35-124

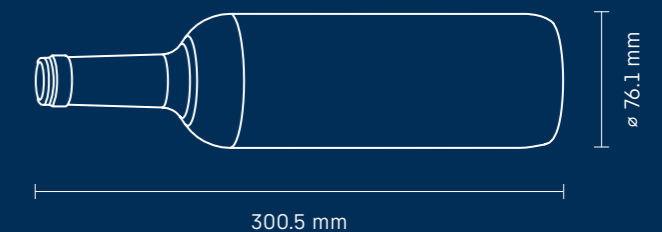

Ideal storage conditions.
Our promise for your favorite wines

Unique features.



LED lighting

The LED lighting in the individual wine compartments can be dimmed to give a pleasing ambient light inside the appliance. All Vinidor appliances are equipped with this innovative, no-heat LED lighting concept. The LED lighting can also be adjusted to operate continuously or in conjunction with door openings.



Insulated glass door

Liebherr wine cabinets come with insulated glass doors with special UV protection. The double-glazed construction means that most of the damaging UV radiation is reflected away. In addition, LED lighting guarantees perfect illumination of the wine cabinet interior without risk of UV exposure.



FreshAir activated charcoal filter

Environmental odours can have an wine stored for longer periods. Fresh air is supplied to Liebherr wine cabinets through the easily replaceable FreshAir activated charcoalfilter to ensure optimal air quality.



Handcrafted beechwood shelves

Our natural, handcrafted, and untreated beechwood shelves release no chemical aromas into the environment that could adversely influence the flavour of wine. In addition, wooden shelves contribute to the reduction of vibrations which allows wine to develop in peace.



Touch electronic control system

Our touch electronic control system is easy to navigate and enables tailored storage options. Temperature can be set between +5°C and +20°C based on your preference. In our multi-temperature models, each wine safe can be controlled independently, allowing different types of wine to be stored in one wine cabinet.



Compressor

Specially developed compressors installed in the wine cabinets from Liebherr ensure that the wines are stored in a particularly low vibration environment.

Created for true wine connoisseurs.

The WTes 5872 Multi-temperature Wine Cabinet satisfies your thirst for the smartest, most elegant ways to store wine. It adds sophisticated flair to entertainment areas while providing ideal conditions for wine to mature successfully. With three adjustable temperature zones, you can simultaneously store red wine, white wine, and champagne all at their optimum serving temperature between +5 °C and +20 °C.

An insulated glass door protects wines from damaging UV radiation while the presentation shelves allow the perfect display of your finest collection. Specially developed compressors provide a low vibration environment and telescopic rails help shelves to slide out gently without causing sudden movements that could damage your wine. An activated charcoal filter provides a permanent supply of odourless, fresh air.

Impress your guests with what is a true wine storage unit.

Technical data see page 98.

- LED
- Wine
- Soft System
- Telescopic Rails
- UV Protection
- Activated Charcoal Filter
- Multi Temperature Zone

WTes 5872



Perfect for reds, whites and champagne.

The **UWTgb 1682** offers a number of innovative solutions for wine storage. The temperature in each of the two sophisticated temperature zones can be set between +5 °C and +20 °C, ensuring optimal storage conditions for reds, whites, and champagnes.

The elegant black glass door, featuring TipOpen technology, offers seamless integration into handle-free kitchen cabinetry. This smart wine cabinet can hold up to 34 Bordeaux bottles and when lightly tapped, the glass door partially opens, facilitating further opening. If the door is not fully opened further within three seconds, the door will self-close, safeguarding your precious wines.

Liebherr's design uses recirculated forced air cooling and a permanent fresh air supply via an easily exchangeable activated charcoal filter. Humidity ranges between 50 % and 80 %, permitting wine to breathe as it matures and to keep corks supple.

Specially developed, quiet compressors ensure that the **UWTgb 1682** produces the lowest vibration possible as fine wines love peace and quiet as much as anyone.

Technical data see page 100.



LED

Wine

Tip
Open

Soft
System

Telescopic
Rails

UV
Protection

Activated
Charcoal
Filter

Multi
Temperature
Zone

UWTgb 1682

Best environment for fine wines.

The wine storage cabinet **WKEgb 582** can be set to exactly the temperature required within the range of +5 °C to +20 °C. This ensures that the selected temperature is maintained constantly and uniformly throughout the interior.

Liebherr's touch opening door with TipOpen technology integrates perfectly into kitchens with a handle-free design. The SoftSystem gentle-closing mechanism cushions movement as the door is shut to ensure extremely gentle closing, preventing vibration, which affects the quality of the wine.

The bottle shelves, made of untreated wood provide an optimum overview and a clear storage layout. The bottles can be stored in opposite directions to make full use of the capacity. The wooden shelves are designed to safely hold Bordeaux bottles.

Technical data see page 101.

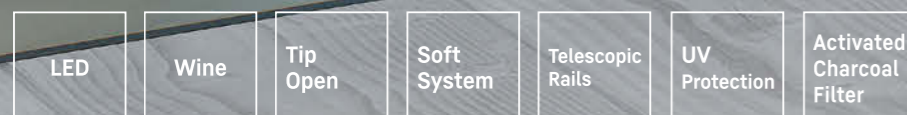

WKEgb 582

Unique features.

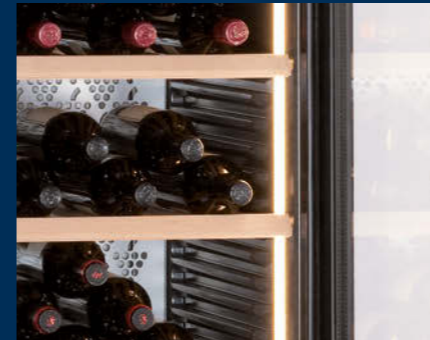

LED lighting

The tinted glass door provides not only a perfect UV protection, but also an optimum glance at wine. The integrated LED lighting ensures a pleasant illumination of the complete interior.



Precision electronics

The precise electronic control system is equipped with a digital temperature display. The door and temperature alarm alerts of any irregularities, e.g. when the door is left open. The integrated lock on the front panel prevents unwanted access to the stored bottles.



Handcrafted beechwood shelves

Our natural, handcrafted, and untreated beechwood shelves release no chemical aromas into the environment that could adversely influence the flavour of wine. In addition, wooden shelves contribute to the reduction of vibrations which allows wine to develop in peace.



Presentation shelf

The presentation shelf, equipped with wooden angles, is ideal for presenting wine and storing open bottles safely. Up to 6 bottles can be set upright on the flexible shelf. In addition further bottles can be stored lying down either behind or at the side.

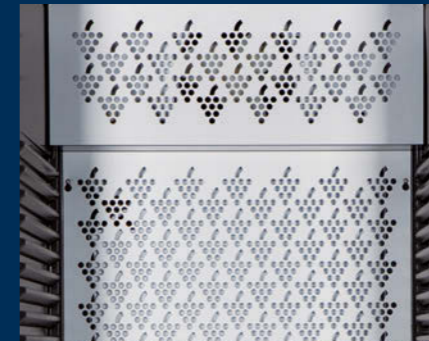

Optimum humidity

Liebherr wine cabinets guarantee an optimum humidity and this ensured the corks are supple in place whilst still allowing the wine to breathe in its maturing process.



Activated charcoal filter

The easy replaceable active charcoal filter purifies the incoming air to obtain an optimum odour-free interior.

Superb conditions for fine wines.

Our most compact model from the Liebherr Barrique series, the **WKb 1712** Wine Cabinet can store up to 60 Bordeaux bottles. Wines are stored optimally on three untreated, height-adjustable beech wood shelves.

Wines are well protected from UV radiation thanks to a tinted insulated glass door while the activated charcoal filter provides optimum air quality and is easy to replace.

Energy-efficient LED lighting ensures even and pleasant illumination so that your favourite bottles are seen in the best light.

Technical data see page 103.



LED

Wine

UV
Protection

Activated
Charcoal
Filter

WKb 1712

Design and lifestyle





Unique features.



LED lighting in humidor

Liebherr's ZKes 453 has LED lighting with dimmer function incorporated in the glass door. As the LEDs emit virtually no heat, the cigars can be exposed to the light for long periods of time without damage.



LED lighting in wine cabinet

For ideal presentation of your best wine, the WKes 653 features LED lighting with dimmer function and separate switch. As the LEDs emit minimal heat and no UV radiation, wine can be showcased bathed in light for lengthy periods without compromising its quality.



Fine cedar wood

Our ZKes 453 humidor features two presentation boxes and two wooden shelves crafted from Spanish cedar wood. The presentation boxes are perfect for storing loose cigars.



Wall mount option

Both the WKes 653 wine cabinet and ZKes 453 humidor can be wall-mounted as an attractive eye-catcher with convenient access for serving.



Ideal humidity

The integrated water tray can accommodate one liter of distilled water for ideal humidity. Sensors regulate precise humidity level selected. The display informs when water needs to be replenished.



Touch electronic control system

The perfect wine storage temperature is +8 °C to +12 °C. White wine should ideally be stored below +10 °C and red wine at up to +18 °C. Our electronic control system allows temperature to be set to the exact degree required between +5 °C to +20 °C.



The perfect indulgence.

The **ZKes 453** Humidor offers the perfect micro-climate for storing beloved cigars through fully-customisable humidity settings. Natural, handmade cigars are both delicate and sensitive, requiring a balanced mix of temperature and humidity to achieve the optimum flavour. The compartments in our humidor are crafted from Spanish cedar wood which allows its aroma to enhance the unique flavour of refined cigars.

For the perfect indulgence, pair the humidor with our **WKes 653** Wine Cabinet. It has a compact footprint yet manages to hold up to 12 Bordeaux bottles. LED lighting and dimmer function ensures perfect illumination for your selection of coveted wines.

Coated with a beautiful SmartSteel surface, both units are easy to clean and maintain. Opt to wall-mount this stunning pair to give it the attention it deserves.

Technical data both models see page 104/105.

- LED
- Wine
- Smart Steel
- Cigar
- UV Protection
- Activated Charcoal Filter

WKes 653 | ZKes 453



Freestanding



SBSes 8486
PremiumPlus



| | |
|---|---|
| Energy consumption (kWh/y) | 405 |
| Climate rating | SN-T (from +10 °C to +43 °C) |
| Max. No. of Bordeaux bottles (0.75l) ¹ | 48 |
| Refrigerator capacity litre (gross/net) | 413 / 366 |
| BioFresh comp. litre (gross/net) | 163 / 132 |
| Wine comp. litre (gross/net) | 173 / 153 |
| Freezer capacity litre (gross/net) | 154 / 126 |
| Number of shelves / Number of door racks | 10 / 5 |
| Number of freezer drawers | 5 with LED lighting |
| Number of BioFresh drawers | 3 with LED lighting |
| Electronic control | 2.4" TFT-colour temp. display, touch electronic |
| Door / side walls | stainless steel with SmartSteel / stainless steel with SmartSteel |
| Refrigerator temperature range °C | +2 °C to +9 °C |
| Freezer temperature range °C | -14 °C to -26 °C |
| Wine temperature range °C | +5 °C to +20 °C |
| Temperature alarm / Defrost type | visual and acoustic / automatic |
| Interior light | LED ceiling lighting with dimmer function |
| Door alarm | visual and acoustic |
| IceMaker / Ice cube output kg/24h | fixed water connection 3/4" / 1.2 |
| SoftSystem | yes |
| Door hinges | left / right |
| Product dimensions (H/W/D) cm | 185 / 121 / 66.5 |
| Net weight kg / Voltage V/Hz | 159 / 220-240/50/60 |



Installation Diagram

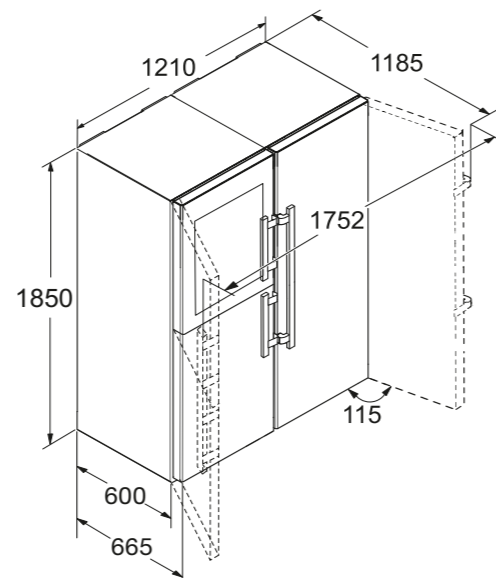
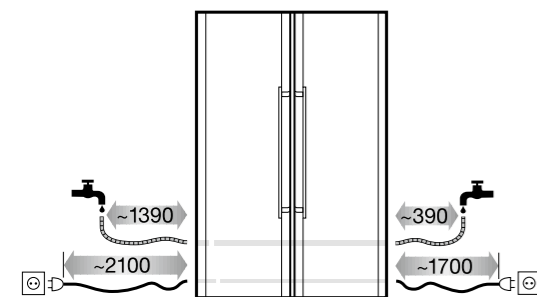

¹Maximum DIN norm bordeaux bottles capacity (0.75 l) as per norm NF H 35-124 (H: 300.5 mm, Ø 76.1 mm).

Freestanding



SBSes 8474
Premium



| | |
|---|---|
| Energy consumption (kWh/y) | 398 |
| Climate rating | SN-T (from +10 °C to +43 °C) |
| Refrigerator capacity litre (gross/net) | 602 / 539 |
| BioFresh comp. litre (gross/net) | 352 / 305 |
| Freezer capacity litre (gross/net) | 154 / 126 |
| Number of shelves | 8 |
| Number of door racks | 5 |
| Number of freezer drawers | 5 with LED lighting |
| Number of BioFresh drawers | 5 with LED lighting |
| Electronic control | 2.4" TFT-colour temp. display, touch electronic |
| Door / side walls | stainless steel with SmartSteel / stainless steel with SmartSteel |
| Refrigerator temperature range °C | +2 °C to +9 °C |
| Freezer temperature range °C | -14 °C to -26 °C |
| Temperature alarm | visual and acoustic |
| Defrost type | automatic |
| Interior light | LED ceiling lighting with dimmer function |
| Door alarm | visual and acoustic |
| IceMaker / Ice cube output kg/24h | fixed water connection 3/4" / 1.2 |
| SoftSystem | yes |
| Door hinges | left / right |
| Product dimensions (H/W/D) cm | 185 / 121 / 66.5 |
| Net weight kg | 163.6 |
| Voltage V/Hz | 220-240/50/60 |



Installation Diagram

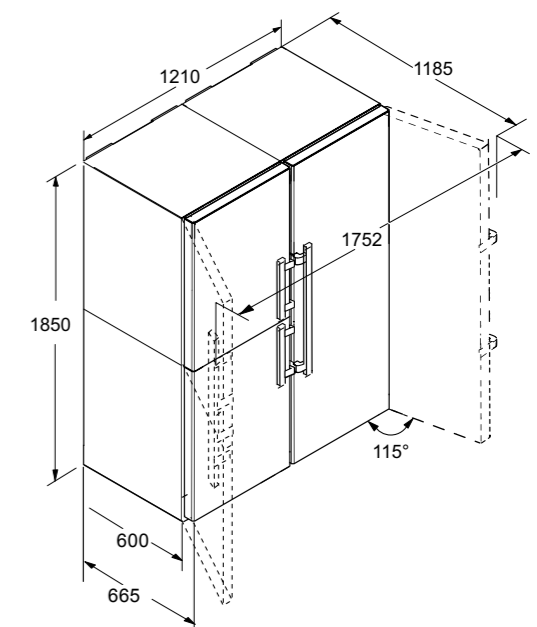
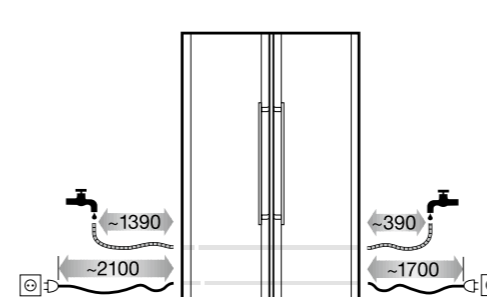

Freestanding



SBSef 7242
Comfort

| | |
|---|---|
| Energy consumption (kWh/y) | 589 |
| Climate rating | SN-T (from +10 °C to +43 °C) |
| Refrigerator capacity litre (gross/net) | 331 / 381 |
| Freezer capacity litre (gross/net) | 303 / 253 |
| Number of shelves | 7 |
| Number of door racks | 5 |
| Number of freezer drawers | 8 |
| Number of fruit and vegetable drawers | 2 |
| Electronic control | MagicEye with digital temp. display, key electronic |
| Door / side walls | stainless steel with SmartSteel / silver |
| Refrigerator temperature range °C | +1 °C to +9 °C |
| Freezer temperature range °C | -14 °C to -26 °C |
| Temperature alarm | visual and acoustic |
| Interior light | LED ceiling lighting |
| Defrost type | automatic |
| Door alarm | acoustic |
| Door hinges | left / right |
| Product dimensions (H/W/D) cm | 185.2 / 121 / 62.3 |
| Net weight kg | 151.5 |
| Voltage V/Hz | 220-240/50/60 |



Installation Diagram

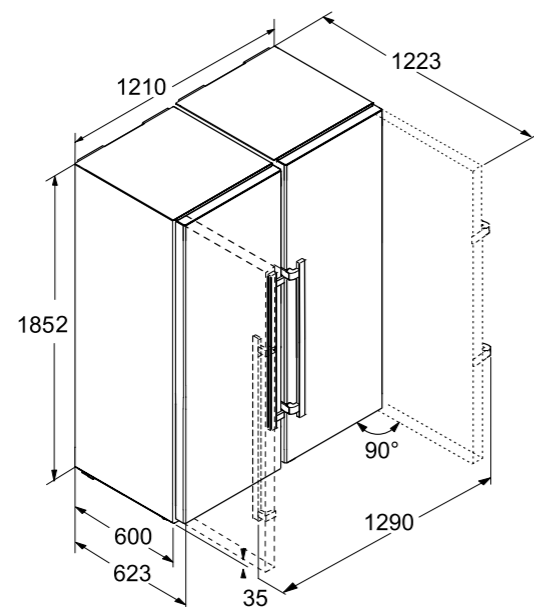

Freestanding



CBNes 6256
PremiumPlus

| | |
|---|---|
| Energy consumption (kWh/y) | 341 |
| Climate rating | SN-T (from +10 °C to +43 °C) |
| Refrigerator capacity litre (gross/net) | 402 / 357 |
| BioFresh comp. litre (gross/net) | 73 / 68 |
| Freezer capacity litre (gross/net) | 183 / 114 |
| Number of shelves | 4 |
| Number of door racks | 6 |
| Number of freezer drawers | 2 with LED lighting |
| Number of BioFresh drawers | 2 with LED lighting |
| Electronic control | MagicEye with digital temp. display, touch electronic |
| Door / side walls | stainless steel / stainless steel |
| Refrigerator temperature range °C | +3 °C to +9 °C |
| Freezer temperature range °C | -14 °C to -28 °C |
| Temperature alarm | visual and acoustic |
| Defrost type | automatic |
| Interior light | LED light column on both sides and LED ceiling lighting |
| Door alarm | acoustic |
| Water filter | yes |
| IceMaker / Ice cube output kg/24h | fixed water connection 3/4" / 0.9 |
| Door hinges | left / right |
| Product dimensions (H/W/D) cm | 203.9 / 91 / 61.5 |
| Net weight kg | 166 |
| Voltage V/Hz | 220-240/50 |



Installation Diagram

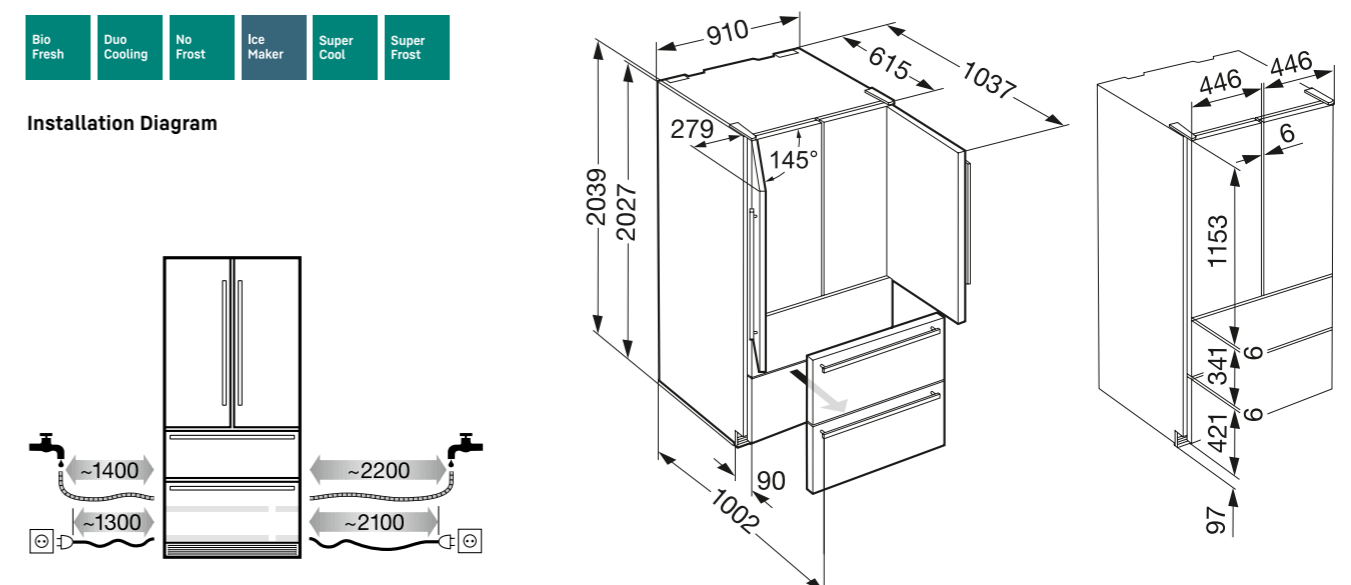

Freestanding



CNPef 4516
Comfort

| | |
|---|---|
| Energy consumption (kWh/y) | 360 |
| Climate rating | SN-T (from +10 °C to +43 °C) |
| Refrigerator capacity litre (gross/net) | 343 / 331 |
| Freezer capacity litre (gross/net) | 99 / 82 |
| Number of shelves | 5 |
| Number of door racks | 4 |
| Number of freezer drawers | 2 |
| Number of fruit and vegetable drawers | 2 with LED lighting |
| Electronic control | MagicEye with LCD temp. display, touch electronic |
| Door / side walls | stainless steel with SmartSteel / silver |
| Refrigerator temperature range °C | +2 °C to +7 °C |
| Freezer temperature range °C | -14 °C to -27 °C |
| Temperature alarm | visual and acoustic |
| Defrost type | automatic |
| Interior light | LED ceiling lighting |
| Door alarm | acoustic |
| Door hinges | right, reversible |
| Product dimensions (H/W/D) cm | 185.9 / 74.7 / 63 |
| Net weight kg | 95 |
| Voltage V/Hz | 220-240/50 |



Installation Diagram

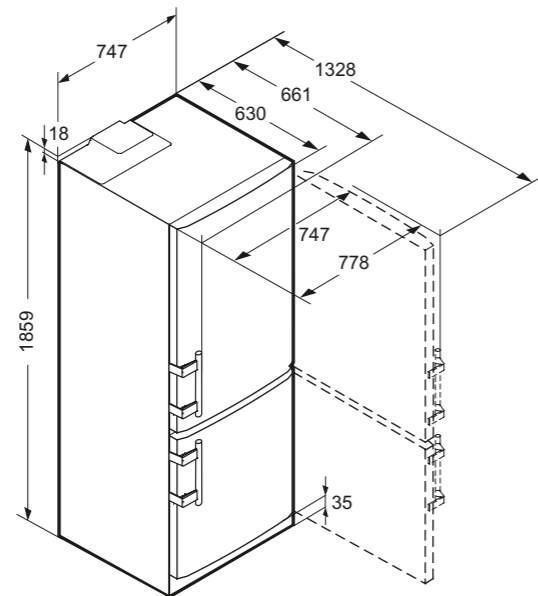

Freestanding



SKBbs 4350
Premium



| | |
|---|---|
| Energy consumption (kWh/y) | 90 |
| Climate rating | SN-T (from +10 °C to +43 °C) |
| Refrigerator capacity litre (gross/net) | 411 / 367 |
| BioFresh comp. litre (gross/net) | 161 / 133 |
| Number of shelves | 6 |
| Number of door racks | 5 |
| Number of BioFresh drawers | 3 with LED lighting |
| Electronic control | 2.4" TFT-colour temp. display, touch electronic |
| Door / side walls | BlackSteel with SmartSteel / BlackSteel with SmartSteel |
| Temperature alarm | visual and acoustic |
| Defrost type | automatic |
| Interior light | LED ceiling lighting with dimmer function |
| Door alarm | visual and acoustic |
| SoftSystem | yes |
| Door hinges | right, reversible |
| Product dimensions (H/W/D) cm | 185 / 60 / 66.5 |
| Net weight kg | 78 |
| Voltage V/Hz | 220-240/50/60 |

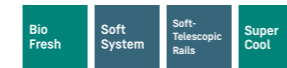

Installation Diagram

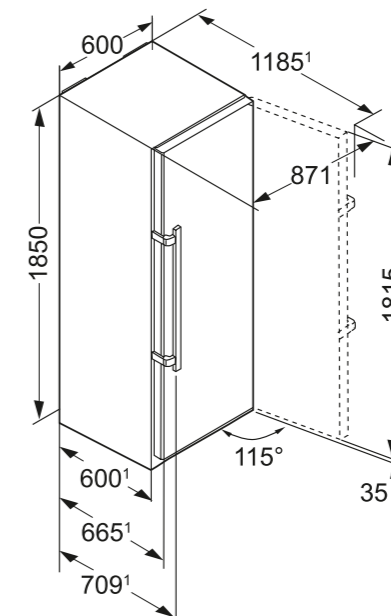

Fully integrated



SICBN 3366
Premium

| | |
|---|---|
| Energy consumption (kWh/y) | 340 |
| Climate rating | SN-T (from +10 °C to +43 °C) |
| Refrigerator capacity litre (gross/net) | 198 / 179 |
| BioFresh comp. litre (gross/net) | 72 / 68 |
| Freezer capacity litre (gross/net) | 81 / 59 |
| Number of shelves | 4 |
| Number of door racks | 2 |
| Number of freezer drawers | 4 with LED lighting |
| Number of BioFresh drawers | 2 with LED lighting |
| Electronic control | MagicEye with LCD temp. display, touch electronic |
| Refrigerator temperature range °C | +3 °C to +9 °C |
| Freezer temperature range °C | -14 °C to -26 °C |
| Temperature alarm | visual and acoustic |
| Defrost type | automatic |
| Interior light | LED light column on both sides |
| Door alarm | acoustic |
| IceMaker / Ice cube output kg/24h | fixed water connection 3/4" / 0.8 |
| SoftSystem | yes |
| Door hinges | left, reversible |
| Product dimensions (H/W/D) cm | 177-178.6 / 55.9 / 54.4 |
| Cut out dimensions (H/W/D) cm | 177.2-178.8 / 56-57 / 55 |
| Net weight kg | 79 |
| Voltage V/Hz | 220-240/50 |

Installation Diagram

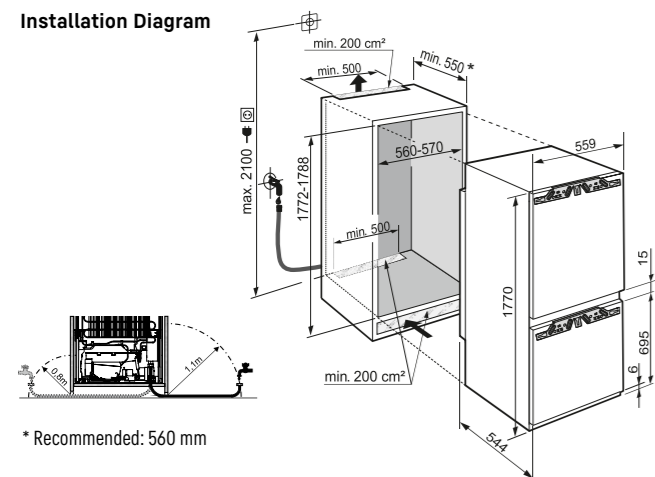

Fully integrated



SICBN 3356
Premium

| | |
|---|---|
| Energy consumption (kWh/y) | 335 |
| Climate rating | SN-T (from +10 °C to +43 °C) |
| Refrigerator capacity litre (gross/net) | 198 / 179 |
| BioFresh comp. litre (gross/net) | 72 / 68 |
| Freezer capacity litre (gross/net) | 81 / 63 |
| Number of shelves | 4 |
| Number of door racks | 2 |
| Number of freezer drawers | 3 with LED lighting |
| Number of BioFresh drawers | 2 with LED lighting |
| Electronic control | MagicEye with LCD temp. display, touch electronic |
| Refrigerator temperature range °C | +3 °C to +9 °C |
| Freezer temperature range °C | -14 °C to -26 °C |
| Temperature alarm | visual and acoustic |
| Defrost type | automatic |
| Interior light | LED light column on both sides |
| Door alarm | acoustic |
| SoftSystem | yes |
| Door hinges | right, reversible |
| Product dimensions (H/W/D) cm | 177-178.6 / 55.9 / 54.4 |
| Cut out dimensions (H/W/D) cm | 177.2-178.8 / 56-57 / 55 |
| Net weight kg | 76.6 |
| Voltage V/Hz | 220-240/50 |

Installation Diagram

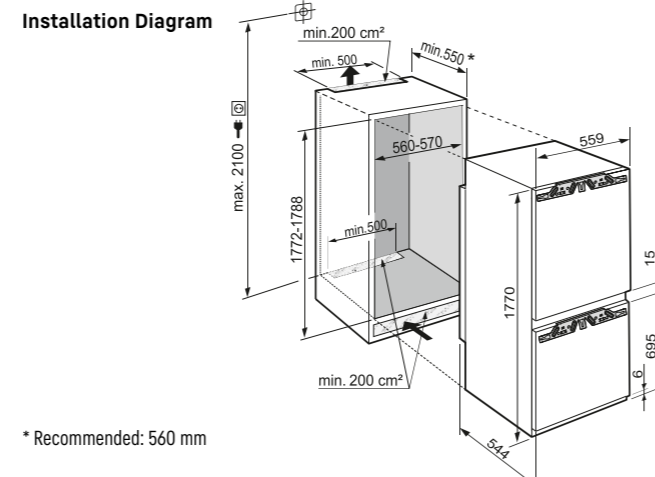

* Recommended: 560 mm



SICN 3314
Comfort

| | |
|---|---|
| Energy consumption (kWh/y) | 300 |
| Climate rating | SN (from +10 °C to +32 °C) |
| Refrigerator capacity litre (gross/net) | 202 / 198 |
| Freezer capacity litre (gross/net) | 81 / 63 |
| Number of shelves | 5 |
| Number of door racks | 3 |
| Number of freezer drawers | 3 |
| Number of BioCool drawers | 1 |
| Electronic control | MagicEye with LCD temp. display, key electronic |
| Refrigerator temperature range °C | +1 °C to +9 °C |
| Freezer temperature range °C | -14 °C to -26 °C |
| Temperature alarm | visual and acoustic |
| Defrost type | automatic |
| Interior light | LED interior lighting |
| Door alarm | acoustic |
| Door hinges | right, reversible |
| Product dimensions (H/W/D) cm | 177-178.6 / 55.9 / 54.4 |
| Cut out dimensions (H/W/D) cm | 177.2-178.8 / 56-57 / 55 |
| Net weight kg | 64.3 |
| Voltage V/Hz | 220-240/50 |

Installation Diagram

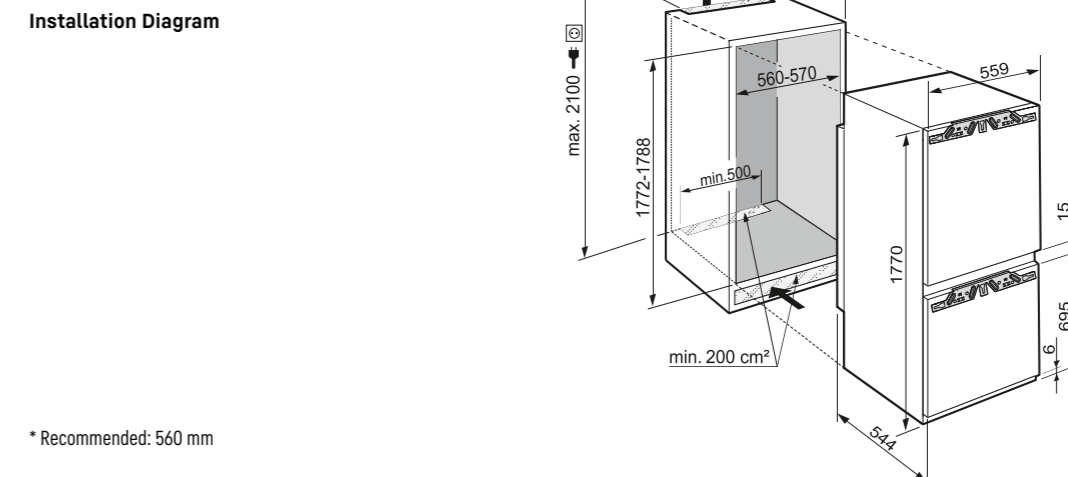

* Recommended: 560 mm

Fully integrated



SIGN 3576
Premium

| | |
|------------------------------------|---|
| Energy consumption (kWh/y) | 331 |
| Climate rating | SN-T (from +10 °C to +43 °C) |
| Freezer capacity litre (gross/net) | 248 / 207 |
| Number of freezer drawers | 9 |
| Electronic control | MagicEye with LCD temp. display, touch electronic |
| Freezer temperature range °C | -15 °C to -28 °C |
| Temperature alarm | visual and acoustic |
| Defrost type | automatic |
| Interior light | LED interior lighting |
| Door alarm | acoustic |
| IceMaker | fixed water connection 3/4" |
| Ice cube output kg/24h | 0.8 |
| SoftSystem | yes |
| Door hinges | left, reversible |
| Product dimensions (H/W/D) cm | 177-178.6 / 55.9 / 54.4 |
| Cut out dimensions (H/W/D) cm | 177.2-178.8 / 56-57 / 55 |
| Net weight kg | 73.9 |
| Voltage V/Hz | 220-240/50 |



Installation Diagram

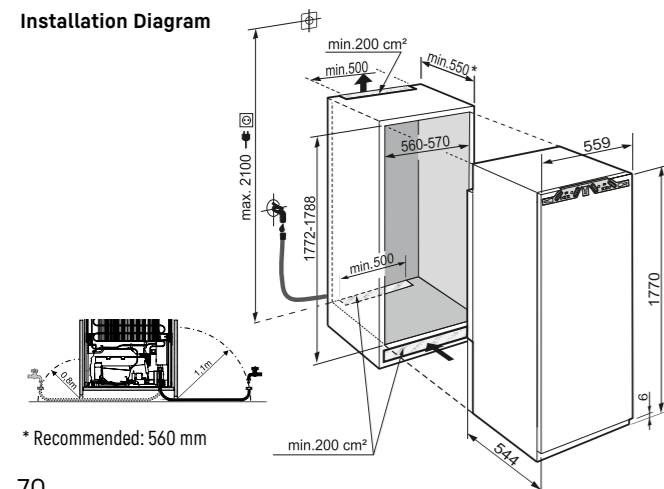

* Recommended: 560 mm

Fully integrated



SIKB 3550
Premium

| | |
|---|---|
| Energy consumption (kWh/y) | 149 |
| Climate rating | SN-T (from +10 °C to +43 °C) |
| Refrigerator capacity litre (gross/net) | 344 / 308 |
| BioFresh comp. litre (gross/net) | 99 / 92 |
| Number of shelves | 8 |
| Number of door racks | 5 |
| Number of BioFresh drawers | 3 with LED lighting |
| Electronic control | MagicEye with LCD temp. display, touch electronic |
| Refrigerator temperature range °C | +3 °C to +9 °C |
| Defrost type | automatic |
| Interior light | LED light column on both sides |
| Door alarm | acoustic |
| SoftSystem | yes |
| Door hinges | right, reversible |
| Product dimensions (H/W/D) cm | 177-178.6 / 55.9 / 54.4 |
| Cut out dimensions (H/W/D) cm | 177.2-178.8 / 56-57 / 55 |
| Net weight kg | 75 |
| Voltage V/Hz | 220-240/50 |



Installation Diagram

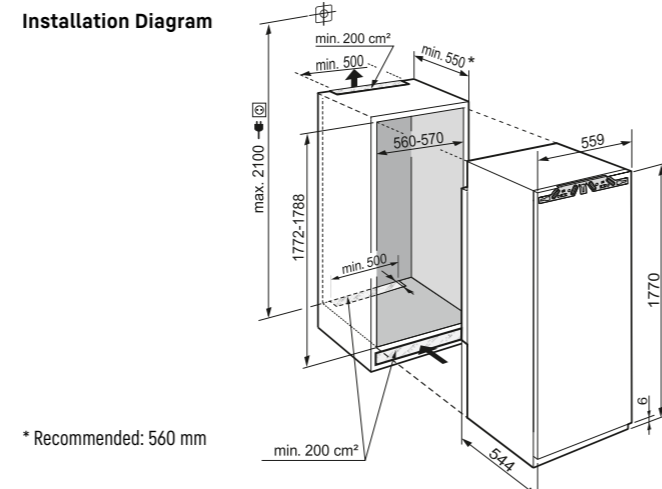

* Recommended: 560 mm



ECBN 6256
PremiumPlus

| | |
|--|---|
| Energy consumption (kWh/y) | 517 |
| Climate rating | SN-T (from +10 °C to +43 °C) |
| Refrigerator capacity litre (gross/net) | 402 / 357 |
| BioFresh comp. litre (gross/net) | 73 / 68 |
| Freezer capacity litre (gross/net) | 183 / 114 |
| Number of shelves / Number of door racks | 4 / 6 |
| Number of freezer drawers | 2 with LED lighting |
| Number of BioFresh drawers | 2 with LED lighting |
| Electronic control | MagicEye with digital temp. display, touch electronic |
| Refrigerator temperature range °C | +3 °C to +9 °C |
| Freezer temperature range °C | -14 °C to -28 °C |
| Temperature alarm | visual and acoustic |
| Defrost type | automatic |
| Interior light | LED light column on both sides and LED ceiling lighting |
| Door alarm | acoustic |
| Water filter | yes |
| IceMaker / Ice cube output kg/24h | fixed water connection 3/4" / 1.3 |
| SoftSystem | yes |
| Door hinges | left / right |
| Product dimensions (H/W/D) cm | 202.7 / 91 / 61 |
| Cut out dimensions (H/W/D) cm | 203.2-207.2 / 91.5 / 63.5 |
| Net weight kg | 159 |
| Voltage V/Hz | 220-240/50 |



Installation Diagram

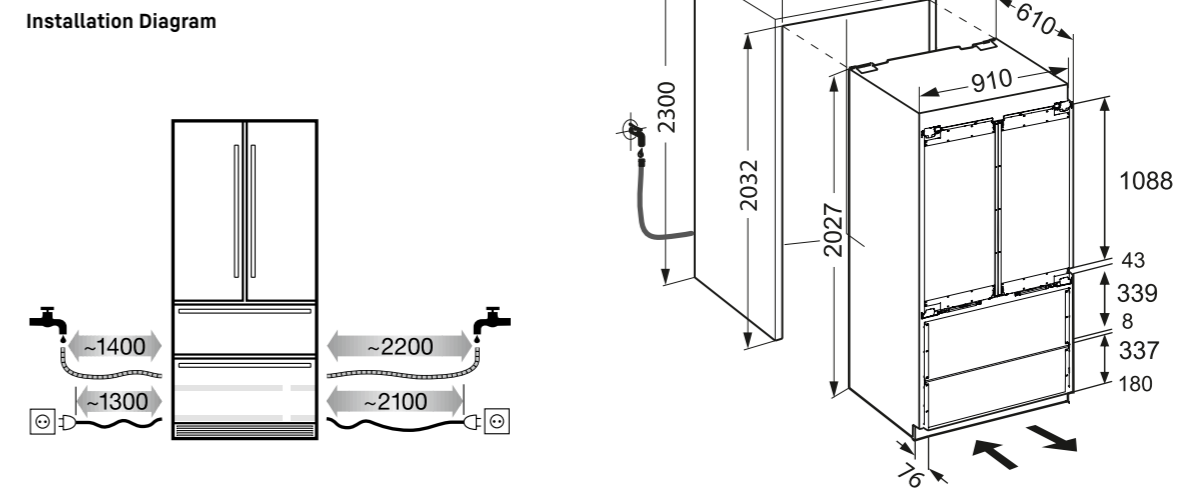



SUIG 1514
Comfort

| | |
|------------------------------------|---|
| Energy consumption (kWh/y) | 168 |
| Climate rating | SN-T (from +10 °C to +43 °C) |
| Freezer capacity litre (gross/net) | 98 / 95 |
| Number of freezer drawers | 3 |
| Electronic control | MagicEye with LCD temp. display, key electronic |
| Freezer temperature range °C | -14 °C to -26 °C |
| Temperature alarm | visual and acoustic |
| Defrost type | manual |
| Door alarm | visual and acoustic |
| Door type | steel |
| SoftSystem | yes |
| Door hinges | left, reversible |
| Product dimensions (H/W/D) cm | 82-88 / 59.7 / 55 |
| Cut out dimensions (H/W/D) cm | 82-88 / 60 / 55 |
| Net weight kg | 38.2 |
| Voltage V/Hz | 220-240/50 |



SUIK 1510
Comfort

| | |
|---|---|
| Energy consumption (kWh/y) | 147 |
| Climate rating | SN-T (from +10 °C to +43 °C) |
| Refrigerator capacity litre (gross/net) | 141 / 136 |
| Number of shelves | 4 |
| Number of door racks | 2 |
| Number of fruit and vegetable drawers | 1 |
| Electronic control | MagicEye with LCD temp. display, key electronic |
| Refrigerator temperature range °C | +2 °C to +9 °C |
| Defrost type | automatic |
| Interior light | LED interior lighting |
| Door alarm | visual and acoustic |
| Door type | steel |
| SoftSystem | yes |
| Door hinges | right, reversible |
| Product dimensions (H/W/D) cm | 82-88 / 59.7 / 55 |
| Cut out dimensions (H/W/D) cm | 82-88 / 60 / 55 |
| Net weight kg | 34.5 |
| Voltage V/Hz | 220-240/50/60 |



Installation Diagram

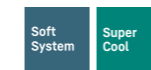
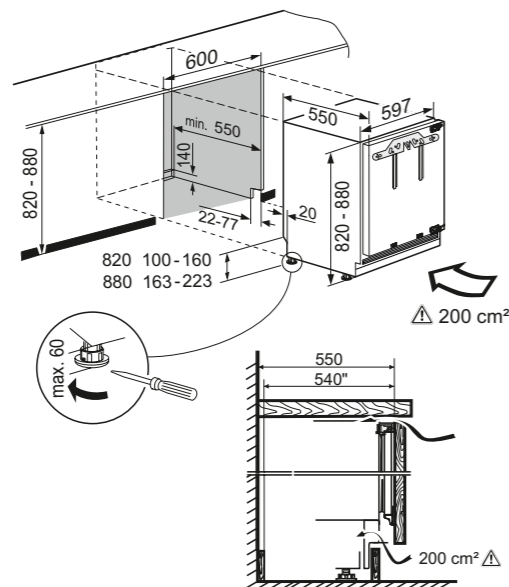

Installation Diagram

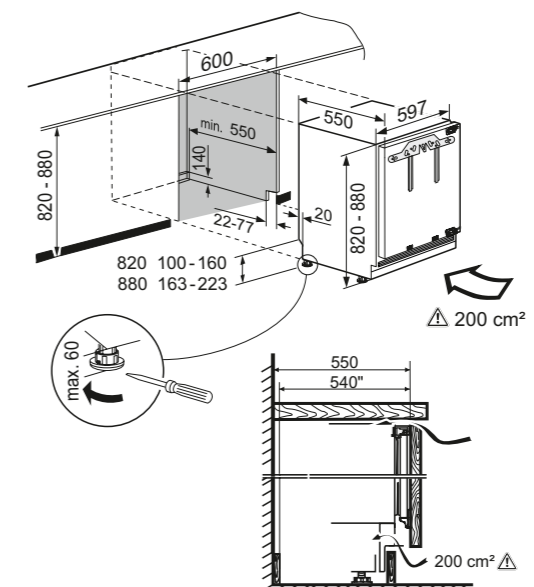



WTes 5872
Vinidor

| | |
|---|--|
| Energy consumption (kWh/y) | 245 |
| Climate rating | T (from +16 °C to +43 °C) |
| Total capacity litre (gross/net) | 584 / 511 |
| Max. No. of Bordeaux bottles (0.75l) ¹ | 178 |
| Total no. of storage shelves (incl. bottom compartment) | 13 |
| Shelves on telescopic rails | 10 |
| Shelf material | beech wood shelves |
| Presentation shelf | 1 |
| Electronic control | LCD temp. display for 3 wine zones, touch electronic |
| Temperature range °C | +5 °C to +20 °C |
| Temperature zones | 3 |
| Temperature alarm | visual and acoustic |
| Interior light | LED lighting permanently on, dimmable |
| Door alarm | acoustic |
| Safety thermostat | yes |
| Activated Charcoal filter | yes |
| Door type | glass door with stainless steel frame |
| Integrated lock | yes |
| SoftSystem | yes |
| Door hinges | right, reversible |
| Product dimensions (H/W/D) cm | 192 / 70 / 74.2 |
| Net weight kg | 137 |
| Voltage V/Hz | 220-240/50 |



Installation Diagram

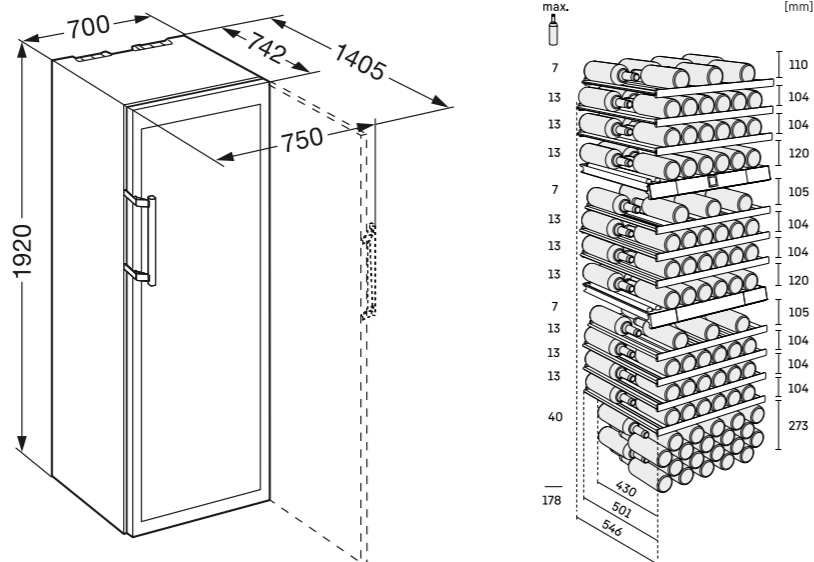

¹These models are only bound for storing wine. Maximum DIN norm bordeaux bottles capacity (0.75 l) as per norm NF H 35-124 (H: 300.5 mm, Ø 76.1 mm).



UWTgb 1682
Vinidor

| | |
|---|---|
| Energy consumption (kWh/y) | 144 |
| Climate rating | SN-ST (from +10 °C to +38 °C) |
| Total capacity litre (gross/net) | 123 / 94 |
| Max. No. of Bordeaux bottles (0.75l) ¹ | 34 |
| Total no. of storage shelves (incl. bottom compartment) | 5 |
| Shelves on telescopic rails | 3 |
| Shelf material | beech wood shelves |
| Electronic control | LCD temp. display for both wine zones, touch electronic |
| Temperature range °C | +5 °C to +20 °C |
| Temperature zones | 2 |
| Temperature alarm | visual and acoustic |
| Interior light | LED lighting permanently on, dimmable |
| Door alarm | acoustic |
| Safety thermostat | yes |
| Activated Charcoal filter | yes |
| Door type | black glass door, handle and frame free |
| SoftSystem | yes |
| Door hinges | right, reversible |
| Product dimensions (H/W/D) cm | 81.8 / 59.7 / 57.7 |
| Cut out dimensions (H/W/D) cm | 82-87 / 60 / 58 |
| Net weight kg | 48 |
| Voltage V/Hz | 220-240/50 |

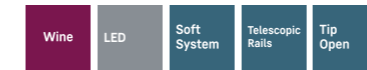

Installation Diagram

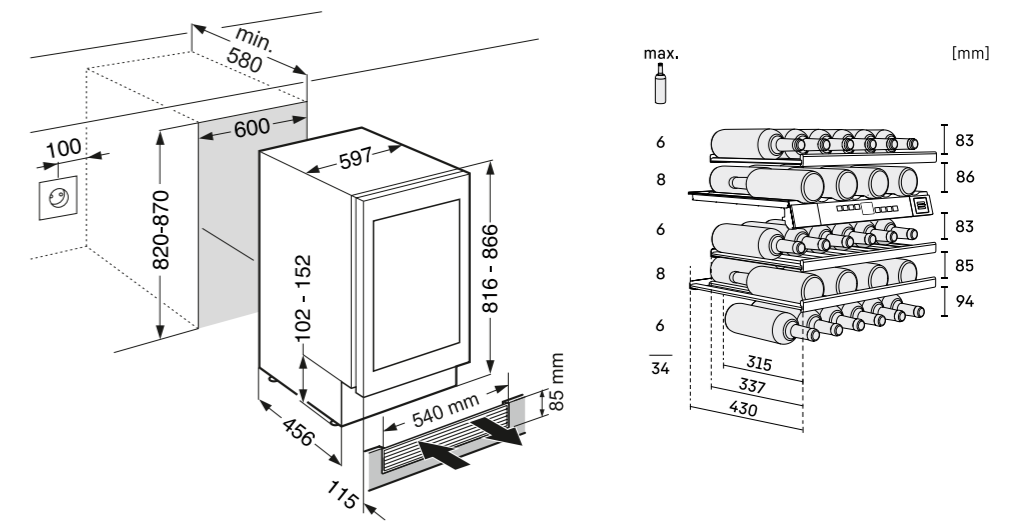



WKEgb 582
GrandCru

| | |
|---|---|
| Energy consumption (kWh/y) | 116 |
| Climate rating | SN-ST (from +10 °C to +38 °C) |
| Total capacity litre (gross/net) | 48 / 46 |
| Max. No. of Bordeaux bottles (0.75l) ¹ | 18 |
| Total no. of storage shelves (incl. bottom compartment) | 3 |
| Shelves on telescopic rails | 2 |
| Shelf material | beech wood shelves |
| Electronic control | LCD temp. display, touch electronic |
| Temperature range °C | +5°C to +20°C |
| Temperature zones | 1 |
| Temperature alarm | visual and acoustic |
| Interior light | LED lighting permanently on, dimmable |
| Door alarm | acoustic |
| Safety thermostat | yes |
| Activated Charcoal filter | yes |
| Door type | black glass door, handle and frame free |
| SoftSystem | yes |
| Product dimensions (H/W/D) cm | 44.8 / 55.5 / 55.9 |
| Cut out dimensions (H/W/D) cm | 45-45.2 / 56-57 / 55 |
| Net weight kg | 33 |
| Voltage V/Hz | 220-240/50 |



WKb 1712
Barrique cabinet

| | |
|---|---|
| Energy consumption (kWh/y) | 149 |
| Climate rating | SN-T (from +10 °C to +43 °C) |
| Total capacity litre (gross/net) | 173 / 121 |
| Max. No. of Bordeaux bottles (0.75l) ¹ | 63 |
| Total no. of storage shelves (incl. bottom compartment) | 3 |
| Shelf material | beech wood shelves |
| Electronic control | MagicEye with digital temp. display, key electronic |
| Temperature range °C | +5°C to +20°C |
| Temperature zones | 1 |
| Temperature alarm | visual and acoustic |
| Interior light | LED lighting permanently on |
| Door alarm | acoustic |
| Safety thermostat | yes |
| Activated Charcoal filter | yes |
| Door type | Insulated glazed door, black frame |
| Integrated lock | yes |
| Door hinges | right, reversible |
| Product dimensions (H/W/D) cm | 85 / 66 / 67 |
| Net weight kg | 45 |
| Voltage V/Hz | 220-240/50 |



Installation Diagram

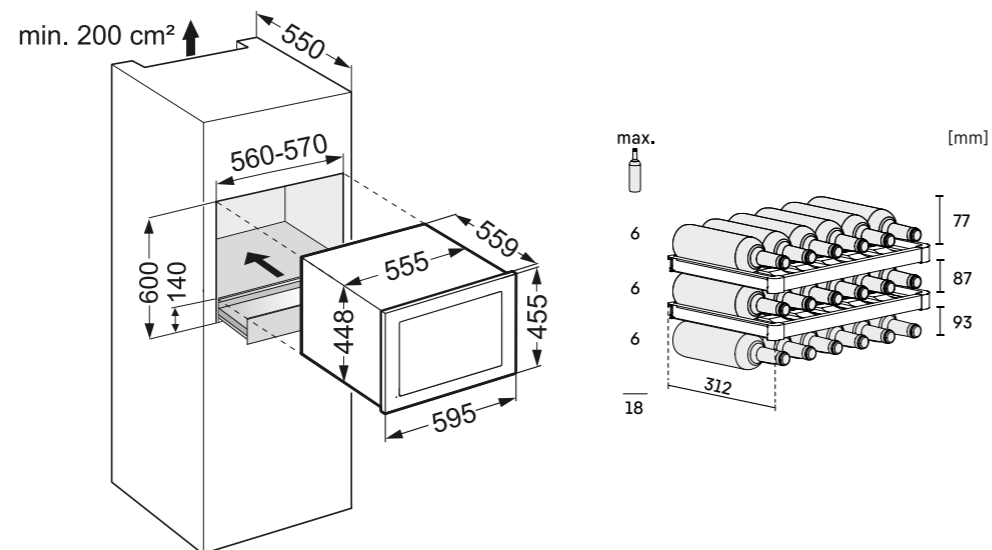

Installation Diagram

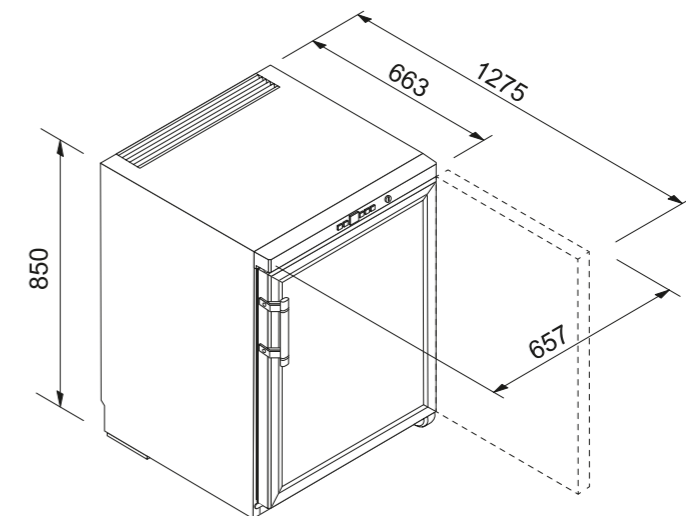



← 43 →

WKes 653
GrandCru

| | |
|---|--|
| Energy consumption (kWh/y) | 78 |
| Climate rating | SN (from +10 °C to +32 °C) |
| Total capacity litre (gross/net) | 56 / 38 |
| Max. No. of Bordeaux bottles (0.75l) ¹ | 12 |
| Total no. of storage shelves (incl. bottom compartment) | 3 |
| Shelf material | beech wood shelves |
| Electronic control | LCD temp. display, touch electronic |
| Temperature range °C | +5 °C to +20 °C |
| Temperature zones | 1 |
| Temperature alarm | visual and acoustic |
| Interior light | LED lighting permanently on, dimmable |
| Door alarm | acoustic |
| Activated Charcoal filter | yes |
| Door type | glass door with stainless steel frame and SmartSteel |
| Integrated lock | yes |
| Door hinges | right |
| Product dimensions (H/W/D) cm | 61.2 / 42.5 / 47.8 |
| Net weight kg | 28 |
| Voltage V/Hz | 220-240/50 |



← 43 →

ZKes 453
Humidor

| | |
|---|--|
| Energy consumption (kWh/y) | 162 |
| Climate rating | N (from +16 °C to +32 °C) |
| Total capacity litre (gross/net) | 43 / 39 |
| Total no. of storage shelves (incl. bottom compartment) | 2 |
| Shelf material | Spanish cedar wood shelves |
| Electronic control | LCD temp. display, touch electronic |
| Temperature range °C | +16 °C to +20 °C |
| Temperature zones | 1 |
| Temperature alarm | visual and acoustic |
| Defrost type | automatic |
| Interior light | LED lighting permanently on, dimmable |
| Door alarm | acoustic |
| Activated Charcoal filter | yes |
| Door type | glass door with stainless steel frame and SmartSteel |
| Integrated lock | yes |
| Door hinges | right |
| Product dimensions (H/W/D) cm | 61.2 / 42.5 / 47.8 |
| Net weight kg | 30 |
| Voltage V/Hz | 220-240/50 |



Installation Diagram

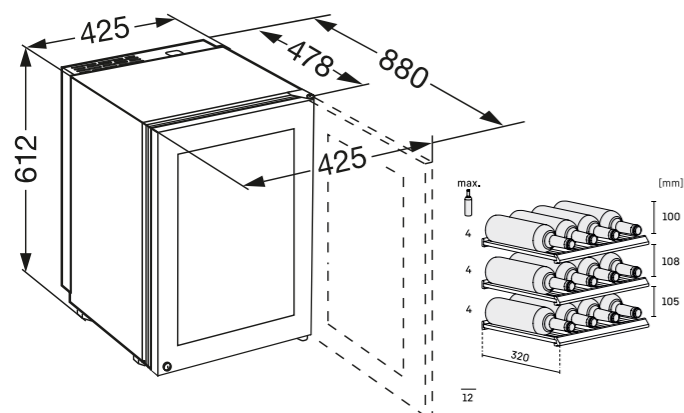

Installation Diagram

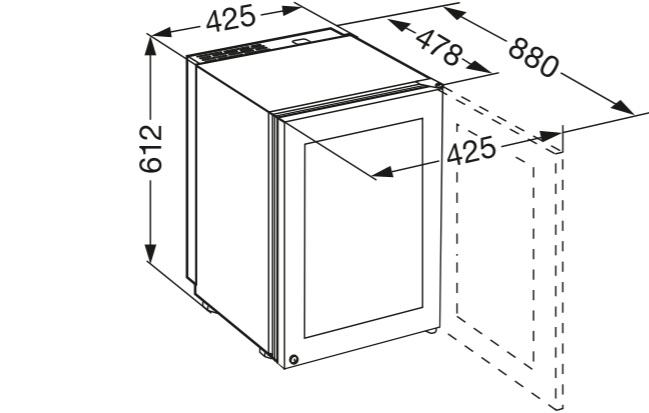

¹These models are only bound for storing wine. Maximum DIN norm bordeaux bottles capacity (0.75 l) as per norm NF H 35-124 (H: 300.5 mm, Ø 76.1 mm).

Our catalogue programme

Ask your Liebherr dealer for our main catalogues for freestanding and fully integrated appliances and for our specials. All catalogues are also available for download at home.liebherr.com.



SmartDevice app: The smart companion for your Liebherr. Operate your appliances conveniently via app, receive important status messages and benefit from many other services relating to your fridge.



HNGRY: The smart every-day assistant for shopping, storage and supplies. The app helps you organise your shopping perfectly, keep an eye on your supplies at all times, and store them correctly.



You can download our apps here.





Visit our social media channels at socialmedia.home.liebherr.com

Liebherr Appliances India Pvt. Ltd.

A1/6 Shendra MIDC | Off Jalna Road | Aurangabad - 431 154 | Maharashtra | India
Customer Care: 7038 100 400 | e-mail: customercare.lhi@liebherr.com

home.liebherr.com

Products and their details are staged for advertising purposes. Whilst every effort is made to ensure all specifications and information in this flyer are accurate, Liebherr reserves the right to make changes without notification. Where actual appliance measurements, specifications, and ratings are crucial, we recommend that the actual appliance installation instructions that accompany each appliance be checked. Liebherr will not be liable for any loss. (220921)
Subject to modification. Current data see home.liebherr.com. Printed in India 2022.