KitchenLine 2024

LIEBHERR

Refrigeration and freezing





Contents

Quality	4
Sustainability	6
Performance in balance	8
Freshness technologies	10
EasyFresh	12
BioFresh	13
Design	14
Convenience and flexibility	16
Connectivity	18
User interface	20
Brief explanation of features	22
Typology	23
Series	24
Range summary	26
Fridge-freezers	30
Series overview	32
Fridges	40
Series overview	42
Freezers	52
Fully integrated appliances glossary	56
Accessories	58

Even the smallest detail deserves the utmost attention.

We prioritise uncompromising quality – down to the tiniest screw. And we have done so from the very start. We have been manufacturing high-quality refrigerators and freezers and selling them worldwide since 1954. However, at heart we are still a family business with deep roots in Germany. It is here that we continue to develop all our products just as before. German engineering – out of loyalty to our founder and with the knowledge built up by generations of engineers.

Convenience for everybody.

Our new freestanding and fully integrated appliances are available in different series: Pure, Plus, Prime and Peak. But whatever series you opt for, every single Liebherr comes with uncompromising Liebherr quality. This is because even in the Pure series, every appliance comes with a wide range of features. One example is NoFrost – the automatic defrosting function. Another is our EasyFresh technology for storing fruit and vegetables. Then there is our DuoCooling feature. With two separate refrigerant circuits, it ensures that no air is exchanged between the fridge and freezer compartments. The stored groceries do not dry out and no odours are transferred.



EasyFresh for fruit and vegetables from the Pure series onwards



IRBSd 5120 ♦ Plus series

Built to last.

You can experience our quality standards in the smallest of details. For example, before a door hinge is approved by us, it must pass through at least 100,000 opening cycles. This corresponds to a usage period of more than 15 years. We also test all other functional parts to ensure that they can last just as long.

And if, contrary to expectations, a small detail no longer meets your requirements, you or our premium service partners can usually correct it quickly. Because all our appliances are extremely repair-friendly. We keep all essential spare parts in stock for well over 10 years. This practice is not just sustainable, it also saves you money on minor repairs or the purchase of a new appliance.

We don't just say it. We also guarantee it.

During manufacturing we inspect all components of our refrigerators with great care and test them far more rigorously than required by law – and we do this for the last time just before they are packaged. It is only then that our appliances can relax a little. All of our manufacturing sites are certified in accordance with the international standards for quality ISO 9001, energy management ISO 50001 and environmental management ISO 14001. Therefore, nothing could be easier for us than to guarantee for at least two years that our products are free of material and manufacturing faults and are particularly easy to install.

In short: one thing is certain – you will be able to enjoy your Liebherr for a long time.



No more defrosting thanks to NoFrost (from the Pure series onwards)

Our path to the future

One thing unites all our product innovations: they all present a path towards greater sustainability. Taking responsibility is one of our core values. That's why we have a decades-long tradition of research and development into eco-friendly products, with the entire product lifecycle in mind.



*** EcoVadis Gold**

Our efforts have been awarded gold for 2023 by EcoVadis, the world's leading Corporate Social Responsibility ratings agency. We are proud to be among the top 3% of companies assessed by EcoVadis.

Recycling/disposal

We are aiming for a sustainable circular economy in the long term and actively design our products to maximise the re-use of the materials in them by making them easy to separate.

Materials

We want to reduce the environmental impact of our business activities and are preparing recyclable products by increasing the use of renewable materials and recycled materials in our appliances and reducing the variety of materials we use. In doing so, we look at the entire product.



Use phase

We reduce our environmental impact by continuing to offer first-class, energy-efficient products that are extremely long-lasting and easy to repair – supported by forward-looking customer service. We also offer products and solutions that help to reduce food waste. More on this on the following pages.

Production

We want to produce in an environmentally conscious manner by reducing the energy requirements of our plants and increasingly utilising renewable energy sources. By using water responsibly, minimising waste and avoiding pollution, we reduce our environmental impact above and beyond CO₂ emissions.*

Perfectly thought out: a powerful, complete package.

Our fridges are real all-rounders. Along with their low power consumption, they also have impressively low noise levels, plenty of space for groceries, a long service life and decent power reserves for when it really matters. We take account of a great many factors during the development stage and can offer a perfectly balanced appliance. Or to put it another way: all good things come in fours.



Performance in balance perfected: Our BluPerformance technology

What is innovative about our BluPerformance models? We have integrated all of the refrigeration technology in the appliance base. As a result, the appliances of the same size have a considerably greater net capacity. So you have noticeably more space for your food and drink. In addition, we were able to further improve energy efficiency thanks to improved ventilation and extraction in the base. And our appliances are now even quieter. We are certain that this technology will appeal not only to fans of new technology.



The current EU energy label for electronic appliances

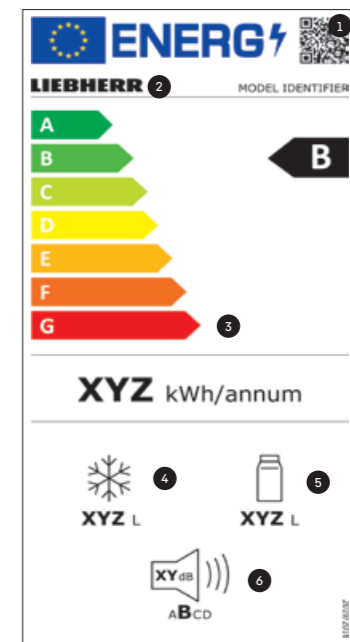

1. The QR code for identifying the product in the EU's EPREL database (European Product Database for Energy Labelling).
2. The model identifier for manual identification of the product in the EU's EPREL database, e.g. using the article number.
3. The new A to G efficiency scale. Note: G is solely used for wine fridges.
4. The total volume of all freezer compartments.
5. The total volume of all cold storage and refrigerator compartments.
6. The noise level is now classified in classes A to D.

Energy consumption

Our new freestanding and fully integrated appliances occupy top positions in the efficiency rankings. In this way, they protect the precious resources of our environment and – thanks to low electricity costs – your wallet too.

Cooling volume

We have the perfect appliance for all family sizes, lifestyles and niche heights. We make sure that we do not waste a single litre of capacity in the extra-large drawers – right down to the smallest detail, for example with the lighting solutions that have been integrated in the housing to save space.

Noise level

The boundaries between the kitchen and living areas are becoming ever more blurred in modern households. This underlines the importance of particularly quiet fridges. Our new freestanding and fully integrated appliances range therefore offers a wide selection of extremely quiet appliances. Some appliances even achieve the ultra-quiet noise level of 29 dB.

Cooling performance

Intelligent sensor technology constantly adapts the cooling performance to current use, making our new freestanding and fully integrated appliances very energy-efficient and economical in everyday use. At the same time they also have plenty of power in reserve, for example to cool down a large quantity of groceries after the weekly shop.



You can find out how efficient our appliances are using the online tool from the EU-financed projects LABEL2020 and BELT. At this site (tool.label2020.eu) you can view and compare the electricity consumption and lots of other product data for electrical appliances. The calculator also takes account of local electricity prices and shows the costs for the entire period of use. The comparison shows that a Liebherr is worth it!

Tasty for longer.

You don't compromise when you're shopping. You look for natural ingredients, the best quality and maximum freshness. Of course, anyone who values good food wants to keep it fresh for as long as possible. That is precisely why we have developed innovative freshness technologies and improve them year after year, so your food still tastes fresh after some time in the refrigerator.



DuoCooling. No drying out.
Our basic technology in all fridge-freezers. The two completely separate refrigeration circuits ensure that there is no air exchange between the fridge and freezer compartments. Groceries do not dry out nor spread odour.



EasyFresh. Ideal for fruit and vegetables.
Unpackaged fruit and vegetables feel right at home here. Stored at the same temperature as the fridge compartment and sealed airtight in the safe, lettuce, for example, is still crisp and fresh after 7 days.



BioFresh. Our all-rounder.
The reliable BioFresh technology stores groceries at a temperature just above 0°C, much cooler than in the rest of the appliance. With the perfect humidity, fruit and vegetables stay fresh even longer in the airtight Fruit & Vegetable safe. Meat, fish and dairy products can enjoy ideal conditions in the Meat & Dairy safe.



BioFresh Professional with HydroBreeze.
Refrigerate like the professionals.
A cold mist that covers fruit and vegetables like a protective balm. It ensures crisp freshness and improves structure – the special wow effect for fruit and vegetables in the BioFresh Professional Safe.



BioFresh Professional with Fish & Seafood Safe.
Like freshly caught fish from the market.
Particularly delicate foods like fish and seafood are best stored in icy temperatures and at low humidity. The constant temperature of -2°C in the Fish & Seafood Safe is therefore ideal to keep items tasting fresh for longer.



SmartFrost. Defrosting is required much less often.
With the SmartFrost technology, ice build-up is greatly reduced. This makes defrosting rarely necessary. The interior walls of the freezer compartment are smooth and easy-to-clean.



NoFrost. No more defrosting.
The automatic defrosting function guarantees that frozen foods remain fresh. There is no longer a need to store frozen food temporarily during manual defrosting. The constant optimal freezing remains the same without interruptions.





Specifications made in days are comparisons to the normal fridge compartment.



Timeless and elegant. Design for every kitchen.

Hidden behind the panels of your built-in kitchen, your Liebherr is inconspicuous and lets the design of the kitchen take the spotlight. But once you open it, it's immediately apparent that behind the door lies something very special.

Design meets functionality.

Puristic and timeless on the one hand. Elegant and exclusive on the other. The new design language blends design and functionality. The high quality glass and stainless steel components are impressive. The precise craftsmanship, an eye for detail and the harmonious combination of materials, shapes and colours create an aesthetically pleasing whole. This is subtly highlighted by the new lighting concept.



For a quick overview of everything in the refrigerator: the LED side lighting helps you to keep your food in view. The LEDs are positioned so that the light beams go up and down. And the LEDs integrated flush into the side walls mean that the valuable usable area is fully maintained.



Just a fan? Not at all: the new fan ensures almost uniform temperature distribution and also includes the FreshAir activated charcoal filter. Functionality at its best.





Fits exactly to your needs.

Fridges and freezers are used daily. They have long been an essential part of our lives. And they should be as simple to use and convenient for you as possible. That's why we develop fully integrated appliance that impress with their ease of use, clarity and flexibility – from the first door opening to the smallest features.

Life is a request show.

The features of the new fully integrated appliance give you more freedom: The divisible glass shelf, with its effortless one-handed operation, creates space for tall containers and carafes. Do you like things to be well organised? With the VarioBox and the VarioSafe you can store smaller objects neatly in the door or interior – always exactly at the height you like.

How about a cold drink? The glass shelf above the BioFresh safe transforms into a bottle shelf in the blink of an eye. The freezer compartment also ensures you are well prepared with an appliance from our new fully-integrated series: VarioSpace creates space for the largest turkey or the highest ice cream cake. Speaking of cake: For all those who love baking, our fridges and fridge-freezers offer enough space for a full baking tray.

Full of food. And convenience.

To ensure that all your food is always perfectly accessible, our appliances have telescopic rails in the fridge and freezer compartments which enable the drawers to slide back and forth with ease. And even once you have found all the ingredients, there is still further convenience. Thanks to the SoftSystem. This means that our doors always close gently and quietly, even if the force applied is a little too strong.



IRd 4520 ♦ Plus series



We are already providing what the future will bring.

One thing is clear: Technology will get smarter and smarter in the future. But does a fridge need to be intelligent? It doesn't have to be. But we believe: Another cool head in the household can't do any harm. Thanks to many smart functions, our appliances have proven themselves to be reliable helpers behind the scenes.



Built-in progress.

Your fridge helps with thoughtful features whenever it can. For example, it reminds you of forgotten drinks in the freezer – thanks to the integrated BottleTimer. Making burst bottles a thing of the past.

NightMode is especially interesting for anyone who is sometimes drawn to the fridge late at night. The interior is then only illuminated with a dimmed light. Then after your midnight snack, you can quickly go back to bed and not wake up from your half-asleep state.



Always perfectly networked.

All our new freestanding and fully integrated appliances are either already networked at the plant or can be subsequently connected to a WiFi network using a SmartDeviceBox. Appliances with a built-in SmartDeviceBox can be identified by the lower-case "i" behind the model designation (e.g.: RBstd 528i). You therefore benefit from all our SmartDevice app options and from integrating the refrigerator into an existing Smart Home environment. This means appliances can be controlled easily via voice-controlled assistants such as Amazon Alexa and Google Assistant or services such as IFTTT and Home Connect Plus (country availability varies).

Important status and alarm notifications are sent directly to your smartphone, for example notification of an open fridge door via door alarm. However, our SmartDevice app has much more to offer. Besides the simple management of all appliances and controlling them while on the move, the app also helps with storing food correctly and therefore provides even greater culinary enjoyment and extends shelf-lives. The right accessories for each refrigerator, access to warranty extensions and much more can also be found here.

In short, our appliances prepare people for tomorrow, today.

We play it very safe.

We take data protection very seriously. For this reason, we have chosen a software partner who shares our high standards: Microsoft. Microsoft, as the first leading provider of cloud services, is certified in accordance with the international standard ISO/IEC 27018, which regulates data protection, and uses AES-256 – the same encryption technology employed in the banking sector.



Learn how digitally networked refrigeration makes your everyday life easier:
home.liebherr.com/getsmart

You can download the SmartDevice app here:









Refrigerators, that leave all your options open – and your doors closed.







We don't develop refrigerators with the most functions. We develop refrigerators with exactly the right functions to store food safely and give our customers what they really need. To make their lives noticeably easier. And then we implement these features to technical perfection.







You can never be too safe.

-  **Door alarm**
Alarm when the door is open, visual as well with pulsating LED lighting.
-  **Temperature alarm**
Visual and audible warning as soon as the temperature in the freezer compartment reaches a critical level.
-  **Power failure alarm**
Visual and audible alarm in case of power failure for safe storage.
-  **Appliance failure alarm**
Optical and acoustic warning in case of appliance failure.
-  **Reminder**
Automatic reminder for maintenance and care.
-  **Input lock**
Prevents all changes to settings or activation of functions.
-  **DemoMode**
For optimal presentation of the appliance at the POS: User interface and lighting on, cooling system off.





A touch more convenience.

-  **CleaningMode**
For a perfect view when cleaning, the lights stay on while the cooling system switches off.
-  **PartyMode**
PartyMode activates functions like SuperCool and maximum ice production.
-  **HolidayMode**
The fan, SuperCool and SuperFrost are switched off and the cooling temperature is increased to +15°C to save electricity. The freezer compartment stays switched on.
-  **EnergySaver**
Raises the standard temperature to maximum 7°C to reduce power consumption.
-  **SabbathMode**
All lighting and sounds are switched off, deactivating themselves after 80 hours.
-  **Language settings***
Variable language setting for 12 languages on the display.
-  **Status indicator**
Be sure everything is OK at all times – thanks to the integrated status display in the appliance door. A blue light indicates everything is OK. If the status is anything but OK, the display flashes red and a warning tone also sounds.

Core competence cooling.

-  **Temperature display**
The display always shows the current temperature value. Flashing items in the menu indicate changes.
-  **SuperFrost**
Better cooling in the freezer compartment for vitamin-preserving freezing.
-  **SuperCool**
Increase the cooling performance until the fresh food is as cool as the rest of the contents.
-  **VarioTemp**
Variable temperature setting between -2°C and +14°C means the entire freezer compartment can also be used for cooling or as a cellar compartment.

Simply smart with the app.

-  **NightMode**
All sounds and noises are switched off – and the lighting is dimmed. For undisturbed quiet.
-  **BottleTimer**
Extra fast cooling by activating SuperFrost. The app sends an automatic reminder to take the bottles out of the ice compartment.
-  **EasyTwist Ice**
Conjure up ice cubes quickly: Fill the tank with water, let it freeze and then release the finished ice cubes with a twist.
-  **IceCubeTimer****
Faster rate of ice cube production. As soon as the ice cubes are ready, the app sends a notification.

Freshness technology

- Bio Fresh** Fruit, vegetables, meat, fish and dairy products stored close to 0 °C and at the ideal humidity will all stay fresh for much longer than if stored in a normal refrigerator compartment.
- Easy Fresh** Fruit and vegetables stay crisp and fresh for longer in the airtight safe.
- Duo Cooling** Two separate and independently controlled cooling circuits for the refrigerator and freezer compartments. Prevents odour transfer and stops food drying out.
- No Frost** Frost-free convenience, forced air system ensures consistent temperature and efficient freezing.
- Smart Frost** Defrosting is required much less often.
- Super Cool** SuperCool boosts the cooling power until the food recently placed inside reaches the temperature of the rest of the contents.
- Super Frost** SuperFrost increases the cooling power for a short time – this means the temperature remains constant when you place in unfrozen food.

Comfort & flexibility

- Soft System** Door closes softly (even if the door shelves are fully loaded) and automatically (from an opening angle of about 30° – 45° depending on model).
- Ultra Silent** Experience silence. Enjoy freshness: our most quiet appliances.
- Super Silent** Shhh – listen carefully. A Liebherr is so quiet that your customers have to strain their ears to hear it.
- Touch-Display** A Liebherr is really simple to use with a gentle tap of a finger on the clear touch display.
- Vario Space** For extra high storage space: Simply take out the individual freezer drawers and the glass horizontal dividers below and make space for extra tall frozen items.
- Side by Side** With the Side-by-Side concept, fridges, freezers and wine cabinets can be individually combined according to personal requirements.

Connectivity

- Smart Device ready** The SmartDeviceBox can be retrofitted to enable appliance control and the use of additional services via computers and mobile devices. Available as an accessory.

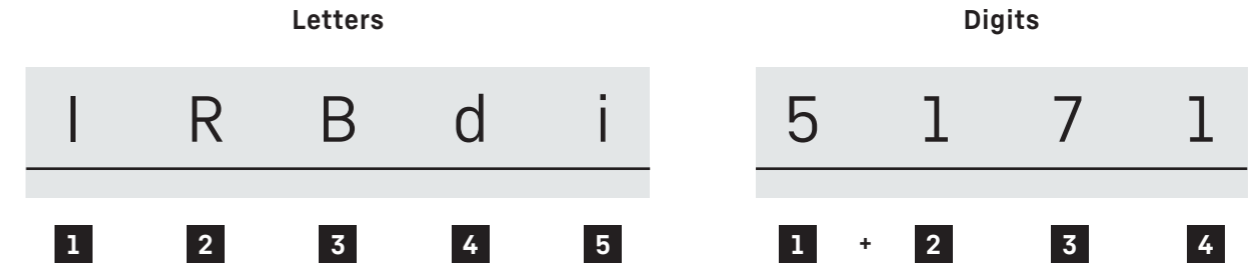

- 1 Type**
 - I Integrated
 - S Side-wall heating (first letter)
- 2 Product classification**
 - R Refrigerator
 - C Combination
 - F Freezer
- 3 Technology & Features**
 - B BioFresh
 - N NoFrost
 - S Sliding Door
- 4 Energy efficiency class**
 - a Energy efficiency class A
 - b Energy efficiency class B
 - c Energy efficiency class C
 - d Energy efficiency class D
 - e Energy efficiency class E
 - f Energy efficiency class F
 - g Energy efficiency class G
- 5 Specification**
 - i SmartDeviceBox integrated

- 1 + 2 Niche**
 - 35 72 cm
 - 39 88 cm
 - 40 102 cm
 - 41 122 cm
 - 45 140 cm
 - 48 158 cm
 - 51 178 cm
- 3 Series**
 - 0-1 Pure
 - 2-4 Plus
 - 5-6 Prime
 - 7-9 Peak
- 4 Specification**
 - Refrigerator**
 - 0 without freezer compartment
 - 1 with freezer compartment
 - Combination / Freezer**
 - 2-8 Freezer drawers

For a clear overview.
Even before you
open the fridge.

○ Pure ◇ Plus ◻ Prime △ Peak

Which appliance is right for me?
A customer question that is not always
easy to answer. That's why we have made
it even simpler for you choose what's
right for you by dividing our product range
into four easy to understand series.

○ Pure series

The Pure series is our basic class. Simple, clear and perfectly equipped for all essential needs. The Pure series has been reduced to the essentials. But full to the brim with the highest level of Liebherr quality.

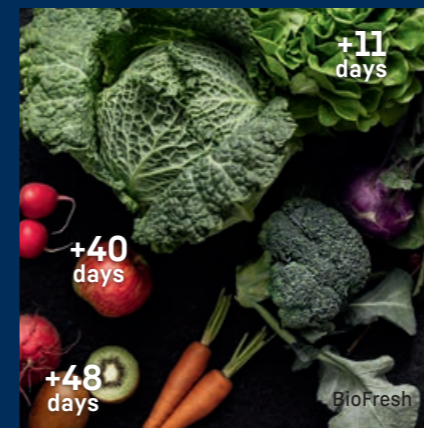

◇ Plus series

The Plus series builds on our Pure series and has many impressive additional details. Above all, plus means a plus in comfort. The appliances not only provide first-class refrigerating and freezing, they are also just that little bit smarter. They help make much of the handling a little easier.

◻ Prime series

With the Prime series things get much more classy. It makes an unmistakable mark in terms of design and material. Above all, genuine materials are used inside the appliances, such as stainless steel. But also special lighting solutions make the appliances in this series particularly appealing.

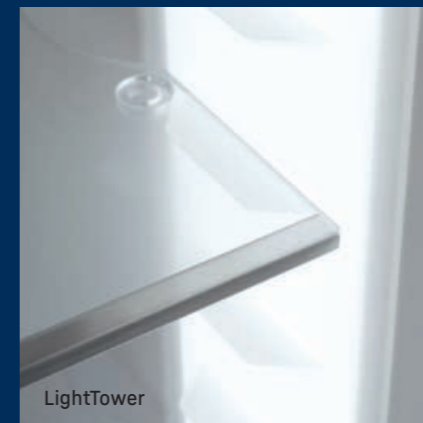

△ Peak series

The Peak series sits at the top of our series. Here the best is combined with the best. There is no compromise. Innovative Liebherr technology meets high-end design and comfort solutions that are simply first in its class. Appliances in this series are for those who want everything.

Fully integrated appliances

◆ Plus series

○ Pure series

Fridge-freezers

Door-on-door	
BioFresh/SmartFrost	ICBc 5122
EasyFresh/NoFrost	ICNd 5103
EasyFresh/SmartFrost	ICd 5103

Sliding door

BioFresh/NoFrost	ICBNSd 5123
EasyFresh/NoFrost	ICNSd 5103
EasyFresh/SmartFrost	ICSe 5103

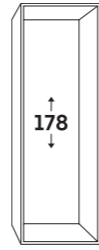

Fridges

Door-on-door			
EasyFresh		IRd 4521	
		IRd 4520	
			IRd 4101
			IRd 4100

Sliding door

BioFresh	IRBSd 5121		IRBSd 4121
	IRBSd 5120		IRBSd 4120

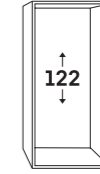
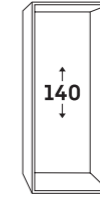
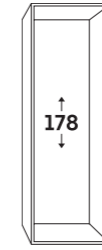

Freezers

Door-on-door	
NoFrost	SIFNe 5128

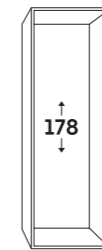

Unique features



BioFresh

At a temperature of just over 0°C and with the ideal humidity, fresh food can keep its appetising appearance and retain healthy vitamins and minerals for considerably longer than in a normal fridge compartment.



EasyFresh

The guarantee of market freshness in the home is our EasyFresh-Safe. Whether it's unpackaged vegetables or fruit, this ensures optimal storage for everything. Thanks to the air-tight closure, the food causes the humidity in the safe to rise. This keeps the food fresh for a long time.



NoFrost

When you open your freezer, you want to see frozen food – and certainly not ice and frost. NoFrost protects the freezer compartment from unwanted icing, which consumes a lot of energy and can be expensive. NoFrost means no more tedious and time-consuming defrosting of the freezer compartment, more time for other things – and saving money.



Touch display

Fingertip control: the touch display enables easy and intuitive operation of your Liebherr. All functions are clearly arranged on the display. By gently tapping a finger, for example, you can easily select the functions or check the current temperature of your refrigerator.



SoftSystem

From breakfast to a midnight snack – a fridge needs to be open and closed on many occasions. And your Liebherr makes this a lot of fun. With the SoftSystem, your fridge door closes softly and safely, and in a way which is pleasantly quiet and light. Bottles stored in the inside door remain securely in place – nothing rattles or wobbles.



Versatile bottle shelf

Expecting guests and want to chill a few more drinks than usual? The bottle shelf above the BioFresh safes exists for this very reason. Simply remove the glass shelf above the bottle shelf in one easy step – and you can now safely store and cool bottles of various sizes.



DuoCooling

DuoCooling uses two completely separate refrigeration circuits to ensure no air is exchanged between the fridge and freezer compartments. The food neither dries out nor is odour transferred. This means throwing less away, shopping less often, but saving more and greater enjoyment.



PowerCooling

Do you want to be sure that the cold is distributed as evenly as possible in your refrigerator? If so, the PowerCooling system is what you need. The fan – as powerful as it is quiet – distributes the cold air efficiently throughout the entire refrigeration compartment.



LED

For a quick overview of everything in the refrigerator: the LED side lighting helps you to keep your food in view. The LEDs are positioned so that the light beams go up and down. And the LEDs integrated flush into the side walls mean that the valuable usable area is fully maintained.



VarioSafe

Do you want a clearly arranged place for small food items such as yoghurt pots, jam jars or tubes? Your Liebherr provides this with the VarioSafe. It not only creates order, but is also highly adaptable. Simply place the two-stage height-adjustable VarioSafe in the refrigerator where it suits you best.



3 bottle shelf

Now your bottles stay where they should. The 3 bottle shelf securely holds three bottles in your fridge ready to be used. The bottle shelf fits on every glass shelf and is therefore very flexible. And if you need the space for other reasons, simply take the shelf out of the fridge.



Space for baking tray

Do you want to keep that home-baked fruit pie fresh? Or maybe a prepared pizza to be baked later on? If so, simply slide your baking tray into your Liebherr – it has plenty of space for storing a baking tray. Really convenient – you can slide the baking tray in and out when the door is opened at 90°.

Fridge-freezers



Series overview



○ Pure series



◇ Plus series

	○ Pure series	◇ Plus series
Freshness technology	EasyFresh	EasyFresh
		BioFresh on telescopic rails
	DuoCooling	DuoCooling
	FreshAir filter	FreshAir filter
	SmartFrost	SmartFrost
	NoFrost	NoFrost
Comfort & flexibility		Divisible glass shelf
		SoftSystem soft stop mechanism
		VarioSafe
	Egg tray	Egg tray
		Bottle shelf
		Ice cube tray
Design	Top fridge compartment lighting	Top fridge compartment lighting
	Transparent glass	Transparent glass
	Touch display	Touch display
Connectivity (SmartDeviceBox)	Can be retrofitted	Can be retrofitted or integrated ("i" models)

The standard features mentioned above may vary depending on the model. Details can be found in the model description.

ICBNSd 5123

Plus

Sliding door / fully integrated appliance

Energy efficiency class:	D <small>A B C D E F G</small>
Energy consumption year / 24 hrs:	207 / 0.567 kWh
Total volume ² :	244 l
Volume: Fridge: 103.3 l / BioFresh compartment: 70.9 l / Freezer compartment: 70.0 l	
Noise output / noise class:	34 dB(A) / B SuperSilent
Climate rating:	SN-ST (+10 °C to +38 °C)
Aperture dimensions in cm (h / w / d):	177.2 – 178.8 / 56 – 57 / at least 55.0



Controls

- LCD display monochrome, Touch electronics
- Digital temperature display for fridge and freezer compartments
- SmartDeviceBox: as an optional accessory
- Warning signal in case of fault: visual and acoustic
- Door alarm: visual and acoustic

Fridge and BioFresh compartments

- PowerCooling with FreshAir activated charcoal filter
- Plastic door shelves with bottle holder, egg tray, FlexCube
- 3 GlassLine storage shelves, of which one is divided into two parts
- Integrated bottle shelf
- LED ceiling lighting
- 2 BioFresh-Safes with partial extension on telescopic rails, 1 Fruit & Vegetable-Safe, 1 Meat & Dairy-Safe

Freezer compartment ****

- 3 drawers, VarioSpace
- Ice cube tray
- Temperature rise time: 9 h
- Freezing capacity in 24 hrs: 6 kg
- Safety glass fittings

Key features

- Height-adjustable feet at front
- Reversible door hinging
- Replaceable door seal



178

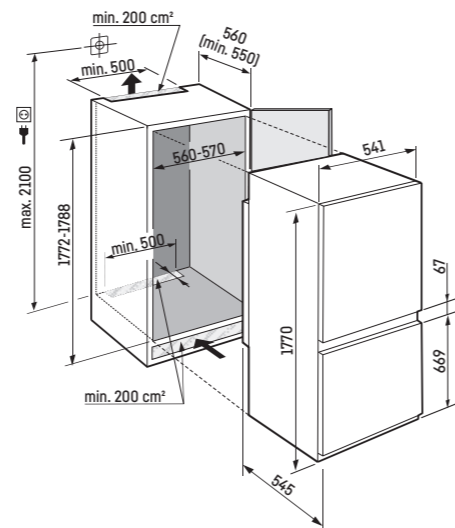

ICBc 5122

Plus

Door-on-door / fully integrated appliance

Energy efficiency class:	C <small>A B C D E F G</small>
Energy consumption year / 24 hrs:	145 / 0.397 kWh
Total volume ² :	255 l
Volume: Fridge: 130.0 l / BioFresh compartment: 70.9 l / Freezer compartment: 54.0 l	
Noise output / noise class:	32 dB(A) / B SuperSilent
Climate rating:	SN-T (+10 °C to +43 °C)
Aperture dimensions in cm (h / w / d):	177.2 – 178.8 / 56 – 57 / at least 55.0



Controls

- LCD display monochrome, Touch electronics
- Digital temperature display for fridge and freezer compartments
- SmartDeviceBox: as an optional accessory
- Warning signal in case of fault: visual and acoustic
- Door alarm: visual and acoustic

Fridge and BioFresh compartments

- PowerCooling with FreshAir activated charcoal filter
- Plastic door shelves with bottle holder, egg tray, FlexCube
- 4 GlassLine storage shelves, of which one is divided into two parts
- Integrated bottle shelf
- LED ceiling lighting
- 2 BioFresh-Safes with partial extension on telescopic rails, 1 Fruit & Vegetable-Safe, 1 Meat & Dairy-Safe

Freezer compartment ****

- 2 drawers, VarioSpace
- Ice cube tray
- Temperature rise time: 9 h
- Freezing capacity in 24 hrs: 4 kg
- Safety glass fittings

Key features

- Height-adjustable feet at front
- Reversible door hinging
- Replaceable door seal



178

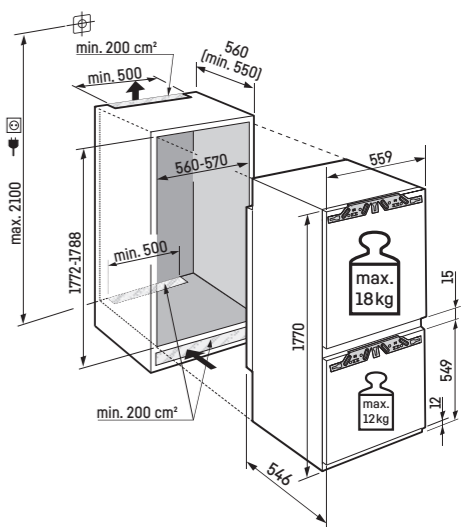

Maximum weight of furniture door:

- Fridge compartment: 18 kg;
- Freezer compartment: 12 kg

NB:

The cupboard door is attached to the appliance door (door on door assembly). No cupboard hinges required.

Fully integrated fridge-freezer

ICNd 5103

Pure

Door-on-door / fully integrated appliance

Energy efficiency class:	D ^A / _B
Energy consumption year / 24 hrs:	181 / 0.495 kWh
Total volume ² :	253 l
Volume:	Fridge: 183.3 l / Freezer compartment: 70.0 l
Noise output / noise class:	34 dB(A) / B SuperSilent
Climate rating:	SN-T (+10 °C to +43 °C)
Aperture dimensions in cm (h / w / d):	177.2 – 178.8 / 56 – 57 / at least 55.0



Controls

- LCD display monochrome, Touch electronics
- Digital temperature display for fridge and freezer compartments
- SmartDeviceBox: as an optional accessory
- Warning signal in case of fault: visual and acoustic
- Door alarm: visual and acoustic

Freezer compartment ****

- 3 drawers, VarioSpace
- Temperature rise time: 9 h
- Freezing capacity in 24 hrs: 6 kg
- Safety glass fittings

Key features

- Height-adjustable feet at front
- Reversible door hinging
- Replaceable door seal

Fridge compartment

- PowerCooling with FreshAir activated charcoal filter
- Plastic door shelves with bottle holder, egg tray
- 4 GlassLine storage shelves
- LED ceiling lighting
- 1 EasyFresh-Safe on integrated drawer guides



Maximum weight of furniture door:

Fridge compartment: 18 kg;
Freezer compartment: 12 kg

NB:

The cupboard door is attached to the appliance door (door on door assembly). No cupboard hinges required.

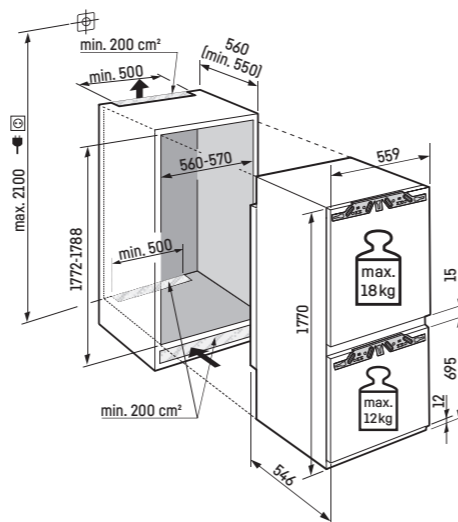

Fully integrated fridge-freezer

ICNSd 5103

Pure

Sliding door / fully integrated appliance

Energy efficiency class:	D ^A / _B
Energy consumption year / 24 hrs:	181 / 0.495 kWh
Total volume ² :	253 l
Volume:	Fridge: 183.3 l / Freezer compartment: 70.0 l
Noise output / noise class:	34 dB(A) / B SuperSilent
Climate rating:	SN-T (+10 °C to +43 °C)
Aperture dimensions in cm (h / w / d):	177.2 – 178.8 / 56 – 57 / at least 55.0



Controls

- LCD display monochrome, Touch electronics
- Digital temperature display for fridge and freezer compartments
- SmartDeviceBox: as an optional accessory
- Warning signal in case of fault: visual and acoustic
- Door alarm: visual and acoustic

Freezer compartment ****

- 3 drawers, VarioSpace
- Temperature rise time: 9 h
- Freezing capacity in 24 hrs: 6 kg
- Safety glass fittings

Key features

- Height-adjustable feet at front
- Reversible door hinging
- Replaceable door seal

Fridge compartment

- PowerCooling with FreshAir activated charcoal filter
- Plastic door shelves with bottle holder, egg tray
- 4 GlassLine storage shelves
- LED ceiling lighting
- 1 EasyFresh-Safe on integrated drawer guides

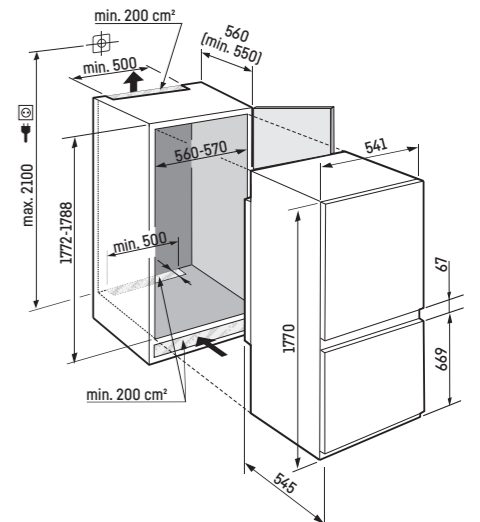

Fully integrated fridge-freezer

ICSe 5103

Pure

Sliding door / fully integrated appliance

Energy efficiency class:	E <small>A G</small>
Energy consumption year / 24 hrs:	228 / 0.624 kWh
Total volume ² :	264 l
Volume:	Fridge: 183.3 l / Freezer compartment: 81.0 l
Noise output / noise class:	34 dB(A) / B SuperSilent
Climate rating:	SN-T (+10 °C to +43 °C)
Aperture dimensions in cm (h / w / d):	177.2 – 178.8 / 56 – 57 / at least 55.0



Controls

- LCD display monochrome, Touch electronics
- Digital temperature display for fridge and freezer compartments
- SmartDeviceBox: as an optional accessory
- Warning signal in case of fault: visual and acoustic
- Door alarm: visual and acoustic

Freezer compartment ****

- 3 drawers, VarioSpace
- Temperature rise time: 11 h
- Freezing capacity in 24 hrs: 6 kg
- Safety glass fittings

Key features

- Height-adjustable feet at front
- Reversible door hinging
- Replaceable door seal

Fridge compartment

- PowerCooling with FreshAir activated charcoal filter
- Plastic door shelves with bottle holder, egg tray
- 4 GlassLine storage shelves
- LED ceiling lighting
- 1 EasyFresh-Safe on integrated drawer guides

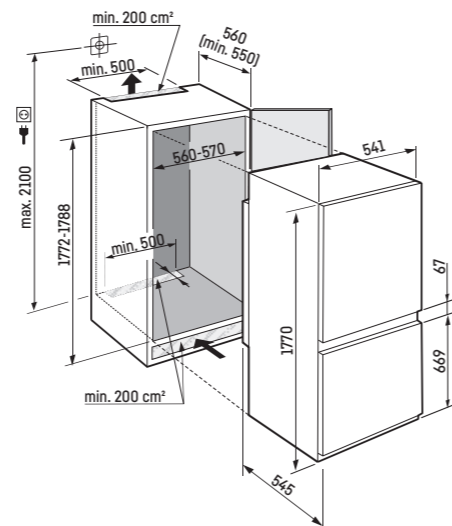

Fully integrated fridge-freezer

ICd 5103

Pure

Door-on-door / fully integrated appliance

Energy efficiency class:	D <small>A G</small>
Energy consumption year / 24 hrs:	183 / 0.501 kWh
Total volume ² :	264 l
Volume:	Fridge: 183.3 l / Freezer compartment: 81.0 l
Noise output / noise class:	33 dB(A) / B SuperSilent
Climate rating:	SN-T (+10 °C to +43 °C)
Aperture dimensions in cm (h / w / d):	177.2 – 178.8 / 56 – 57 / at least 55.0



Controls

- LCD display monochrome, Touch electronics
- Digital temperature display for fridge and freezer compartments
- SmartDeviceBox: as an optional accessory
- Warning signal in case of fault: visual and acoustic
- Door alarm: visual and acoustic

Freezer compartment ****

- 3 drawers, VarioSpace
- Temperature rise time: 11 h
- Freezing capacity in 24 hrs: 6 kg
- Safety glass fittings

Key features

- Height-adjustable feet at front
- Reversible door hinging
- Replaceable door seal

Fridge compartment

- PowerCooling with FreshAir activated charcoal filter
- Plastic door shelves with bottle holder, egg tray
- 4 GlassLine storage shelves
- LED ceiling lighting
- 1 EasyFresh-Safe on integrated drawer guides

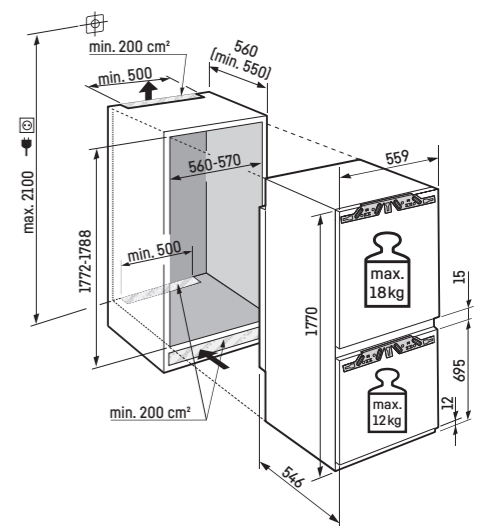

Maximum weight of furniture door:

- Fridge compartment: 18 kg;
- Freezer compartment: 12 kg

NB:

The cupboard door is attached to the appliance door (door on door assembly). No cupboard hinges required.

Fridges



Series overview



○ Pure series



◇ Plus series

	○ Pure series	◇ Plus series
Freshness technology	EasyFresh	EasyFresh
		BioFresh on telescopic rails
Comfort & flexibility	FreshAir filter	FreshAir filter
		Divisible glass shelf
		SoftSystem soft stop mechanism
		VarioSafe
	Egg tray	Egg tray
		Bottle shelf
Design		Ice cube tray
	Top or side fridge compartment lighting	Top or side fridge compartment lighting
	Transparent glass	Transparent glass
	Touch display	Touch display
Connectivity (SmartDeviceBox)	Can be retrofitted	Can be retrofitted or integrated ("i" models)

The standard features mentioned above may vary depending on the model. Details can be found in the model description.

IRBSd 5121

Plus

Sliding door / fully integrated appliance

Energy efficiency class:	D <small>A B C D E F G</small>
Energy consumption year / 24 hrs:	164 / 0.449 kWh
Total volume ² :	275 l
Volume:	Fridge: 150.2 l / BioFresh compartment: 98.2 l / Freezer compartment: 27.0 l
Noise output / noise class:	34 dB(A) / B SuperSilent
Climate rating:	SN-T (+10 °C to +43 °C)
Aperture dimensions in cm (h / w / d):	177.2 - 178.8 / 56 - 57 / at least 55.0



Controls

- LCD display monochrome, Touch electronics
- Digital temperature display for fridge compartment
- SmartDeviceBox: as an optional accessory
- Warning signal in case of fault: visual and acoustic
- Door alarm: visual and acoustic

Fridge and BioFresh compartments

- PowerCooling with FreshAir activated charcoal filter
- Plastic door shelves with bottle holder, egg tray, FlexCube
- 4 GlassLine storage shelves, of which one is divided into two parts
- Integrated bottle shelf
- LED light on both sides
- 3 BioFresh-Safes with partial extension on telescopic rails, 2 Fruit & Vegetable-Safes, 1 Meat & Dairy-Safe

Freezer compartment ********

- 4-star freezer compartment, reversible door hinging
- Ice cube tray
- Temperature rise time: 14 h
- Freezing capacity in 24 hrs: 2 kg
- Glass shelf

Key features

- Height-adjustable feet at front
- Reversible door hinging
- Replaceable door seal



178

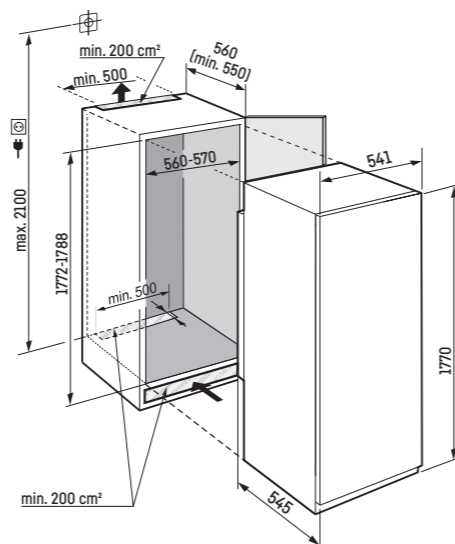

IRBSd 5120

Plus

Sliding door / fully integrated appliance

Energy efficiency class:	D <small>A B C D E F G</small>
Energy consumption year / 24 hrs:	125 / 0.342 kWh
Total volume ² :	294 l
Volume:	Fridge: 195.8 l / BioFresh compartment: 98.2 l
Noise output / noise class:	33 dB(A) / B SuperSilent
Climate rating:	SN-T (+10 °C to +43 °C)
Aperture dimensions in cm (h / w / d):	177.2 - 178.8 / 56 - 57 / at least 55.0



Controls

- LCD display monochrome, Touch electronics
- Digital temperature display for fridge compartment
- SmartDeviceBox: as an optional accessory
- Warning signal in case of fault: visual and acoustic
- Door alarm: visual and acoustic

Fridge and BioFresh compartments

- PowerCooling with FreshAir activated charcoal filter
- Plastic door shelves with bottle holder, egg tray, FlexCube
- 6 GlassLine storage shelves, of which one is divided into two parts
- Integrated bottle shelf
- LED ceiling lighting
- 3 BioFresh-Safes with partial extension on telescopic rails, 2 Fruit & Vegetable-Safes, 1 Meat & Dairy-Safe

Key features

- Height-adjustable feet at front
- Reversible door hinging
- Replaceable door seal



178

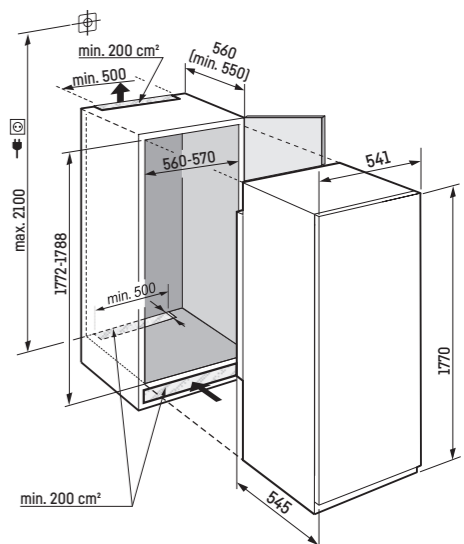

IRd 4521

Plus

Door-on-door / fully integrated appliance

Energy efficiency class:	D <small>A G</small>
Energy consumption year / 24 hrs:	122 / 0.334 kWh
Total volume ² :	217 l
Volume:	Fridge: 202.0 l / Freezer compartment: 16.0 l
Noise output / noise class:	33 dB(A) / B SuperSilent
Climate rating:	SN-T (+10 °C to +43 °C)
Aperture dimensions in cm (h / w / d):	139.7 – 141.3 / 56 – 57 / at least 55.0



Controls

- LCD display monochrome, Touch electronics
- Digital temperature display for fridge compartment
- SmartDeviceBox: as an optional accessory
- Warning signal in case of fault: visual and acoustic
- Door alarm: visual and acoustic

Fridge compartment

- Plastic door shelves with bottle holder, egg tray, FlexCube
- 6 GlassLine storage shelves, of which one is divided into two parts
- VarioSafe
- 3 bottle shelf
- LED light on both sides
- 1 EasyFresh-Safe on integrated drawer guides

Freezer compartment ********

- 4-star freezer compartment, reversible door hinging
- Ice cube tray
- Temperature rise time: 9 h
- Freezing capacity in 24 hrs: 2 kg

Key features

- Height-adjustable feet at front
- Reversible door hinging
- Replaceable door seal



Maximum weight of furniture door:

Fridge compartment: 21 kg

NB:

The cupboard door is attached to the appliance door (door on door assembly). No cupboard hinges required.

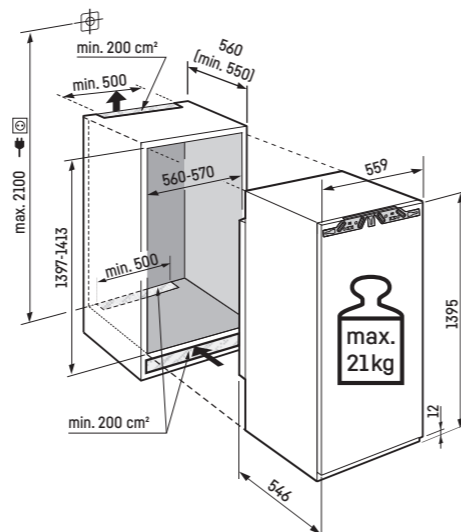

IRd 4520

Plus

Door-on-door / fully integrated appliance

Energy efficiency class:	D <small>A G</small>
Energy consumption year / 24 hrs:	84 / 0.230 kWh
Total volume ² :	235 l
Noise output / noise class:	33 dB(A) / B SuperSilent
Climate rating:	SN-T (+10 °C to +43 °C)
Aperture dimensions in cm (h / w / d):	139.7 – 141.3 / 56 – 57 / at least 55.0



Controls

- LCD display monochrome, Touch electronics
- Digital temperature display
- SmartDeviceBox: as an optional accessory
- Warning signal in case of fault: visual and acoustic
- Door alarm: visual and acoustic

Fridge compartment

- PowerCooling with FreshAir activated charcoal filter
- Plastic door shelves with bottle holder, egg tray, FlexCube
- 7 GlassLine storage shelves, of which one is divided into two parts
- VarioSafe
- 3 bottle shelf
- LED ceiling lighting
- 1 EasyFresh-Safe on integrated drawer guides

Key features

- Height-adjustable feet at front
- Reversible door hinging
- Replaceable door seal



Maximum weight of furniture door:

Fridge compartment: 21 kg

NB:

The cupboard door is attached to the appliance door (door on door assembly). No cupboard hinges required.

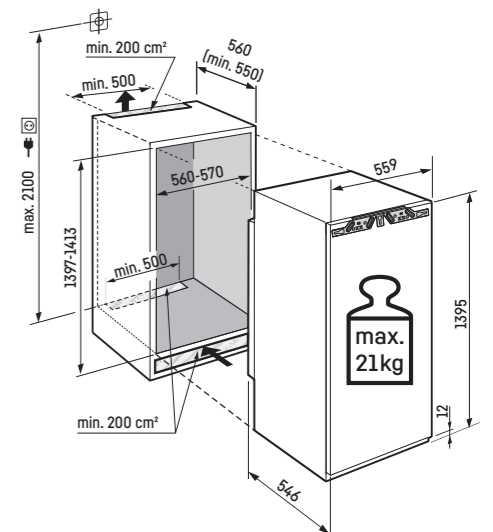

IRBSd 4121

Plus

Sliding door / fully integrated appliance

Energy efficiency class:	D <small>A B C D E F G</small>
Energy consumption year / 24 hrs:	148 / 0.405 kWh
Total volume ² :	173 l
Volume:	Fridge: 90.9 l / BioFresh compartment: 66.8 l / Freezer compartment: 16.0 l
Noise output / noise class:	33 dB(A) / B SuperSilent
Climate rating:	SN-T (+10 °C to +43 °C)
Aperture dimensions in cm (h / w / d):	121.6 – 123.1 / 56 – 57 / at least 55.0



Controls

- LCD display monochrome, Touch electronics
- Digital temperature display for fridge compartment
- SmartDeviceBox: as an optional accessory
- Warning signal in case of fault: visual and acoustic
- Door alarm: visual and acoustic

Fridge and BioFresh compartments

- PowerCooling with FreshAir activated charcoal filter
- Plastic door shelves with bottle holder, egg tray, FlexCube
- 2 GlassLine storage shelves, of which one is divided into two parts
- Integrated bottle shelf
- LED light on both sides
- 2 BioFresh-Safes with partial extension on telescopic rails, 1 Fruit & Vegetable-Safe, 1 Meat & Dairy-Safe

Freezer compartment ********

- 4-star freezer compartment, reversible door hinging
- Ice cube tray
- Temperature rise time: 9 h
- Freezing capacity in 24 hrs: 2 kg

Key features

- Height-adjustable feet at front
- Reversible door hinging
- Replaceable door seal



122

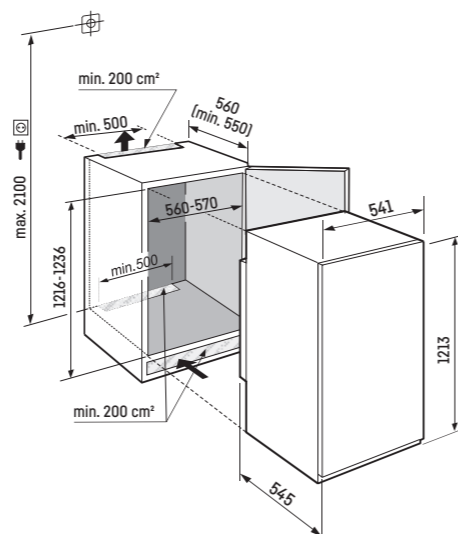

IRBSd 4120

Plus

Sliding door / fully integrated appliance

Energy efficiency class:	D <small>A B C D E F G</small>
Energy consumption year / 24 hrs:	114 / 0.312 kWh
Total volume ² :	189 l
Volume:	Fridge: 123.0 l / BioFresh compartment: 66.8 l
Noise output / noise class:	35 dB(A) / B SuperSilent
Climate rating:	SN-T (+10 °C to +43 °C)
Aperture dimensions in cm (h / w / d):	121.6 – 123.1 / 56 – 57 / at least 55.0



Controls

- LCD display monochrome, Touch electronics
- Digital temperature display for fridge compartment
- SmartDeviceBox: as an optional accessory
- Warning signal in case of fault: visual and acoustic
- Door alarm: visual and acoustic

Fridge and BioFresh compartments

- PowerCooling with FreshAir activated charcoal filter
- Plastic door shelves with bottle holder, egg tray, FlexCube
- 4 GlassLine storage shelves, of which one is divided into two parts
- Integrated bottle shelf
- LED ceiling lighting
- 2 BioFresh-Safes with partial extension on telescopic rails, 1 Fruit & Vegetable-Safe, 1 Meat & Dairy-Safe

Key features

- Height-adjustable feet at front
- Reversible door hinging
- Replaceable door seal



122

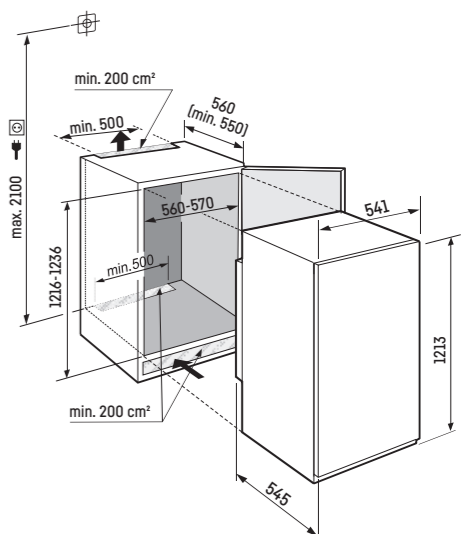

IRd 4101

Pure

Door-on-door / fully integrated appliance

Energy efficiency class:	D <small>A G</small>
Energy consumption year / 24 hrs:	119 / 0.326 kWh
Total volume ² :	182 l
Volume:	Fridge: 166.5 l / Freezer compartment: 16.0 l
Noise output / noise class:	32 dB(A) / B SuperSilent
Climate rating:	SN-T (+10 °C to +43 °C)
Aperture dimensions in cm (h / w / d):	121.6 – 123.1 / 56 – 57 / at least 55.0



Controls

- LCD display monochrome, Touch electronics
- Digital temperature display for fridge compartment
- SmartDeviceBox: as an optional accessory
- Warning signal in case of fault: visual and acoustic
- Door alarm: visual and acoustic

Fridge compartment

- Plastic door shelves with bottle holder, egg tray
- 4 GlassLine storage shelves
- LED light on both sides
- 1 EasyFresh-Safe on integrated drawer guides

Freezer compartment ********

- 4-star freezer compartment, reversible door hinging
- Temperature rise time: 9 h
- Freezing capacity in 24 hrs: 2 kg

Key features

- Height-adjustable feet at front
- Reversible door hinging
- Replaceable door seal



Maximum weight of furniture door:

Fridge compartment: 19 kg

NB:

The cupboard door is attached to the appliance door (door on door assembly). No cupboard hinges required.

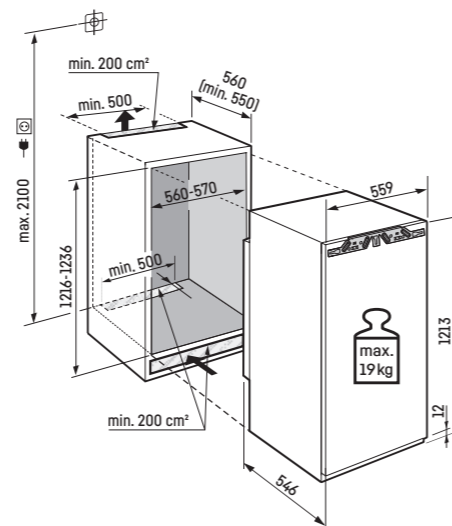

IRd 4100

Pure

Door-on-door / fully integrated appliance

Energy efficiency class:	D <small>A G</small>
Energy consumption year / 24 hrs:	81 / 0.221 kWh
Total volume ² :	201 l
Noise output / noise class:	27 dB(A) / A UltraSilent
Climate rating:	SN-T (+10 °C to +43 °C)
Aperture dimensions in cm (h / w / d):	121.6 – 123.1 / 56 – 57 / at least 55.0



Controls

- LCD display monochrome, Touch electronics
- Digital temperature display
- SmartDeviceBox: as an optional accessory
- Warning signal in case of fault: visual and acoustic
- Door alarm: visual and acoustic

Fridge compartment

- Plastic door shelves with bottle holder, egg tray
- 5 GlassLine storage shelves
- LED ceiling lighting
- 1 EasyFresh-Safe on integrated drawer guides

Key features

- Height-adjustable feet at front
- Reversible door hinging
- Replaceable door seal



Maximum weight of furniture door:

Fridge compartment: 19 kg

NB:

The cupboard door is attached to the appliance door (door on door assembly). No cupboard hinges required.

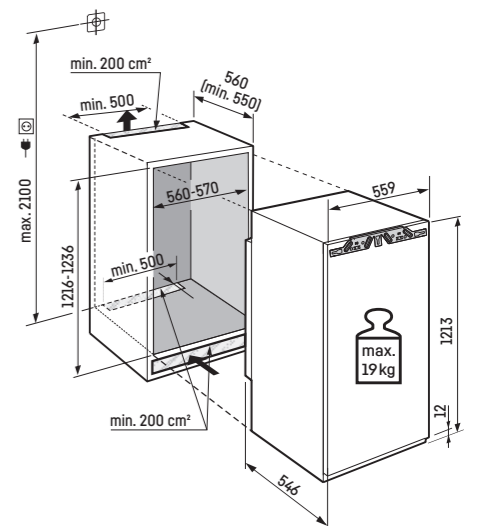

Freezers



SIFNe 5128 ◊ Plus series

SIFNe 5128

Plus

Door-on-door / fully integrated appliance

Energy efficiency class:	E
Energy consumption year / 24 hrs:	237 / 0.649 kWh
Total volume ² :	213 l
Noise output / noise class:	33 dB(A) / B SuperSilent
Climate rating:	SN-T (+10 °C to +43 °C)
Aperture dimensions in cm (h / w / d):	177.2 - 178.8 / 56 - 57 / at least 55.0



Controls

- LCD display monochrome, Touch electronics
- Digital temperature display
- SmartDeviceBox: as an optional accessory
- Warning signal in case of fault: visual and acoustic
- Door alarm: visual and acoustic

Key features

- Side wall heating on both sides, suitable for combination with other refrigerators, freezers and/or wine appliances
- Height-adjustable feet at front
- Reversible door hinge, left
- Replaceable door seal

Freezer compartment ********

- 8 drawers on integrated drawer guides, VarioSpace
- Ice cube tray
- Temperature rise time: 9 h
- Freezing capacity in 24 hrs: 12 kg
- Freezer tray



Maximum weight of furniture door:
Freezer compartment: 26 kg

NB:

The cupboard door is attached to the appliance door (door on door assembly). No cupboard hinges required.

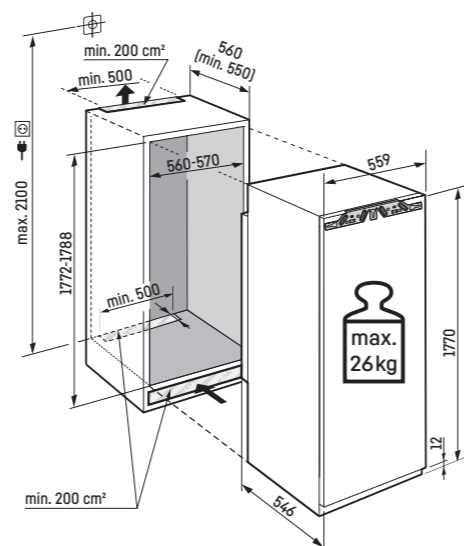

Unique features



NoFrost

The NoFrost system from Liebherr provides rapid, fan-assisted, frost-free freezing for the safe, longterm storage of food. The NoFrost technology creates a much larger storage capacity and keeps the freezer constantly frost-free.



SoftSystem

The stylish SoftSystem mechanism is integrated into the door and matches the colour of the interior door; it conveniently cushions movement to ensure extremely soft closure even when the door shelves are fully stocked. The door closes automatically from an opening angle of about 30°.



Touch display

Fingertip control: the touch display enables easy and intuitive operation of your Liebherr. All functions are clearly arranged on the display. By gently tapping a finger, for example, you can easily select the functions or check the current temperature of your refrigerator.



Replaceable door seal

Do you think the door seal on your Liebherr needs to be replaced after a few years? This is very easy to do yourself. The replaceable door seal can be removed in a few simple steps – and the new seal is just as easy to insert. As a result, this part of the refrigerator is always spotless and hygienically clean.



VarioSpace

Want to store a multi-layer ice cream cake safely until the summer party? No problem for your Liebherr freezer: Sometimes you just need more space and it's prepared for just that. With VarioSpace you can remove individual freezer drawers and the horizontal glass dividers below them, and hey presto, you have an extra large storage space.

² In accordance with Regulation EU 2019/2016 we indicate the total volume to the nearest integer (rounded off) and the volume of the frozen compartments and refrigeration compartments to one place after the decimal point. You can find the full range of efficiency classes on page 9. According to (EU) 2017/1369 6a.

The features shown are model specific; the description applies to the relevant model.



Aperture dimensions

The dimensions for fully integrated appliances are industry standard. The aperture dimensions provide information about the appliance size or height. The exact dimensions of each appliance can be seen in the installation diagrams on the pages that follow.

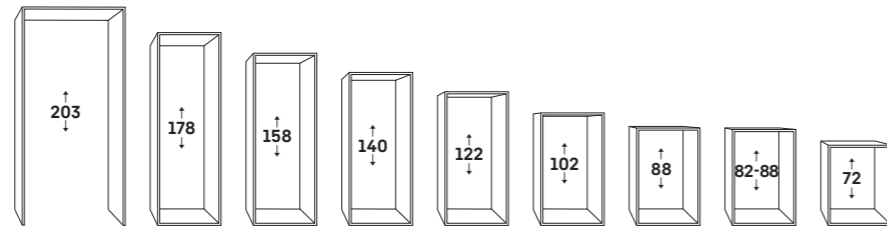

SN	from +10 °C to +32 °C
ST	from +16 °C to +38 °C
N	from +16 °C to +32 °C
T	from +16 °C to +43 °C

Climate class

The climate rating specifies the ambient temperature for which the appliances are guaranteed to work normally. The following climate ratings have been defined (pursuant to DIN EN ISO 15502):

Outstanding energy efficiency

By combining state-of-the-art, precision electronics and highly efficient refrigeration systems, Liebherr offers an attractive and ultra-economical range of appliances in the best energy efficiency classes across all product groups. Liebherr offers products with the greatest possible energy savings. You can find the full range of efficiency classes on page 9. According to (EU) 2017/1369 6a.

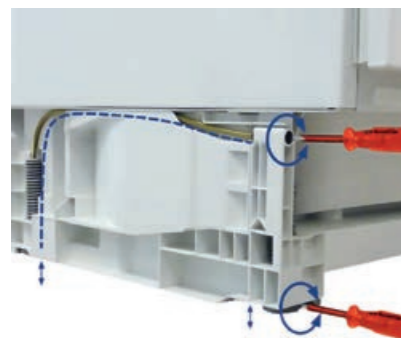
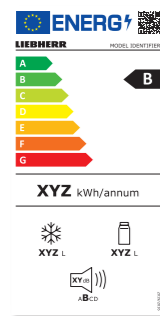

Vario plinth

The Vario plinth makes it possible to adapt under-worktop models (UIK, SUIG, UWT and UWK) to the height and depth of the kitchen units. All four positioning feet can be adjusted by up to 50 mm from the front. The position of the ventilation grille can also be adjusted to match the front of the kitchen units; it can be moved by up to 55 mm.



Levelling bars

Taller appliances with a height of 140 cm or more have two levelling bars on the left and right of the base. These make it possible to correctly level position the appliance and thereby ensure that the door closes correctly so that the appliance works properly.

Front air intake and ventilation

To ensure that the refrigeration system is cooled and the appliance operates correctly, fully integrated appliances must be adequately ventilated. Depending on the model and the installation location:

- 1** – Fully integrated appliances in non-ceiling height kitchen units. Front air intake in the plinth, venting via the back wall of the kitchen unit.
- 2** – Fully integrated appliances in ceiling height kitchen units. Front air intake in the plinth, venting via ventilation slots at the top.
- 3** – In the case of individual fully integrated appliances installed one above the other (Freshness Centre / SBS Concept) ventilation takes place as described in 1 and 2.
- 4** – Fully integrated appliances with both air intake and venting at the front.
- 5** – Under-worktop appliances with front air intake in the plinth. Venting via ventilation slots at the top.
- 6** – Under-worktop appliances with both air intake and venting at the front. Please note: All ventilation slots must be at least 200 cm².



Practical accessories for every need.

Discover the versatility of the original Liebherr range of accessories for your fridge – and make your daily life a little easier.



Organisational systems

A fridge compartment design to suit your needs: If you want to sort your groceries clearly, you could use the VarioSafe, VarioBoxes, variable egg trays and the FlexSystem, for example. Additional bottle shelves and clip-on labelling systems provide a clear overview of wine stocks.



VarioBoxes



FlexSystem



Bottle shelf

Useful help of all kinds

From the practical butter dish to the easy-fill ice cube tray with a lid or the handy freezer tray, the range of accessories offers plenty of smart solutions for serving food and keeping it fresh.



Ice cube tray with lid

The large ice cube tray is easy to fill with water thanks to its convenient fill opening. The lid seals on tightly so that the tray can be safely moved and placed in the appliance without spills.



FreshAir activated charcoal filter

Cleans the circulating air and quickly binds unpleasant odours. The filter is easy to replace and ensures optimum air quality.



SmartDeviceBox

You can retrofit your Liebherr with a SmartDeviceBox to connect it to the internet. The SmartDeviceBox can be installed in just a few steps and will open up the whole world of digital possibilities to you today.



Perfect installation – perfect appearance

Connecting sets, stainless steel frames and fronts with matching handles or drawers for accessories: the product range features many accessories that can help integrate a built-in appliance in the kitchen in an individual and visually perfect fashion.

Stay in touch

Our catalogues

Find out everything you need to know about Liebherr Freestanding & Fully integrated refrigeration as well as Wine Cabinets. Liebherr also manufacture a comprehensive range of Commercial refrigeration. Available as PDF downloads from home.liebherr.com.



SmartDevice app: Your smart companion for your Liebherr. Control your appliances conveniently via the app, receive important status messages and benefit from many other services around your appliance.



HNGRY: Your smart everyday assistant for shopping, storage and inventory. The app helps you to perfectly organise your grocery shopping, keep an eye on your food stocks and store them properly.



You can download our apps here.



WarrantyPLUS

Benefit from many advantages of an extension of 2 or 4 years Warranty. Further information under home.liebherr.com/promotions or contact your Liebherr specialist dealers Partner.



Liebherr-Hausgeräte Marica EOOD

E-mail: home.see@liebherr.com

home.liebherr.com

Subject to technical changes.
Colour deviations depending on media type.
For latest available data, see home.liebherr.com.
Printed in Germany by mediaprint solutions GmbH, 04,24

