

Übersetzung

Operating instructions

Chest freezer

Read the operating instructions before switching on for the first time

Page 12

EN

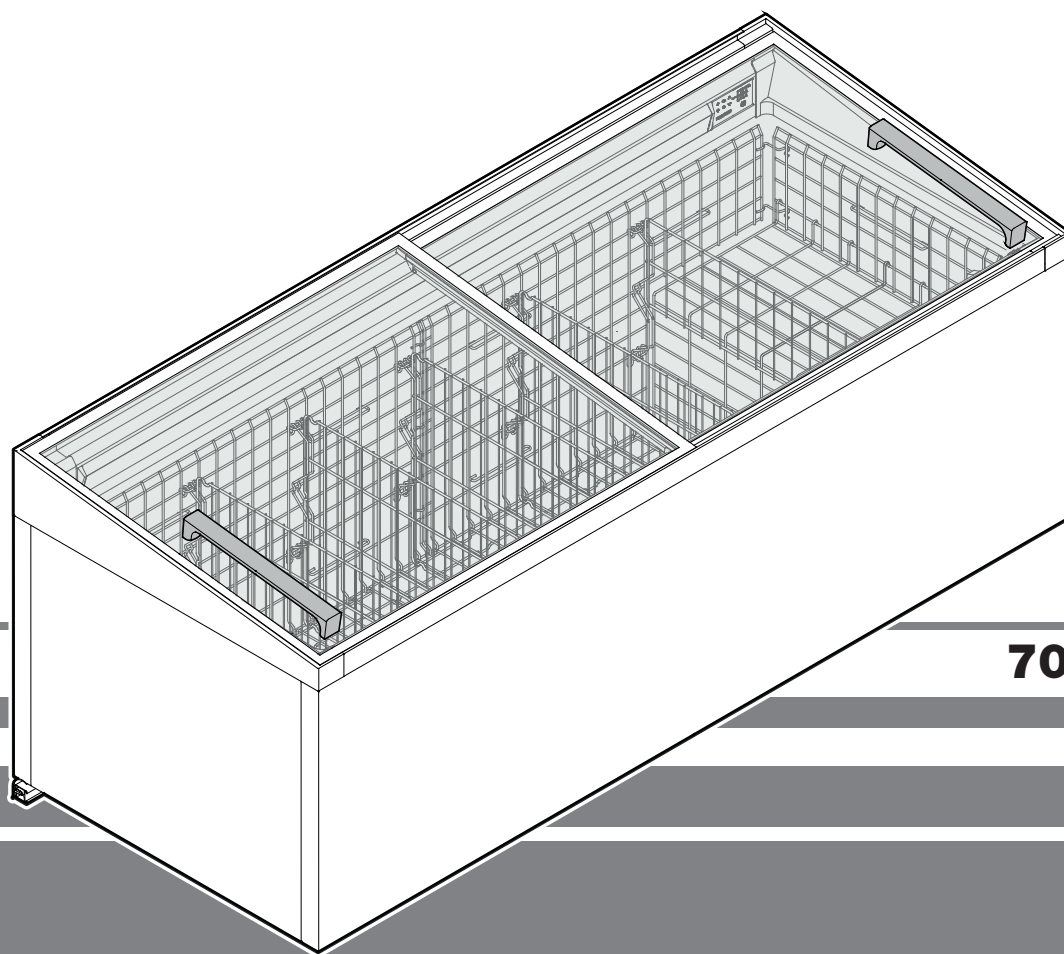

7084 808-00

LIEBHERR

Content

Range of appliance use.....	12
Appliance dimensions.....	12
Safety instructions and warnings.....	13
Disposal instructions for packaging material.....	13
Climate rating.....	13
Noise emissions from the appliance.....	13
Display in indicating mode.....	14
Setup mode.....	14
Activating setup mode.....	14
Setting the real time clock.....	14
Changing the temperature setting.....	15
Activating the defrost function manually.....	15
Interior light.....	15
(depending on options).....	15
Malfunctions.....	15
Switching the appliance off.....	16
Switching the appliance on.....	16
Cleaning.....	16
Removing the lids.....	16
Fitting the lids.....	17
Removing the grids.....	17
Cleaning the interior.....	18
Inserting the grids.....	18
Repositioning the support brackets.....	21
Customer service.....	21
Shutting down the appliance.....	21
Disposal notes.....	21

Range of appliance use

This appliance is only suitable for **storing food that has already been frozen**.

The appliance is not suitable for freezing fresh food.

Any misuse of the appliance may result in damage to or spoilage of stored goods.

Appliance dimensions

	Width [mm]	Height [mm]	Depth [mm]
SGTEs 772	1800	840	850
SGTs 872/852	2100	840	850
SGTEm 872	1800	890	850
SGTm 972/952	2100	890	850
SGTs 1072/1052	2500	840	850
SGTm 1172/1152	2500	890	850

Description of the appliance

Stacking limit marking

The appliance may be filled up to the stacking limit marking .

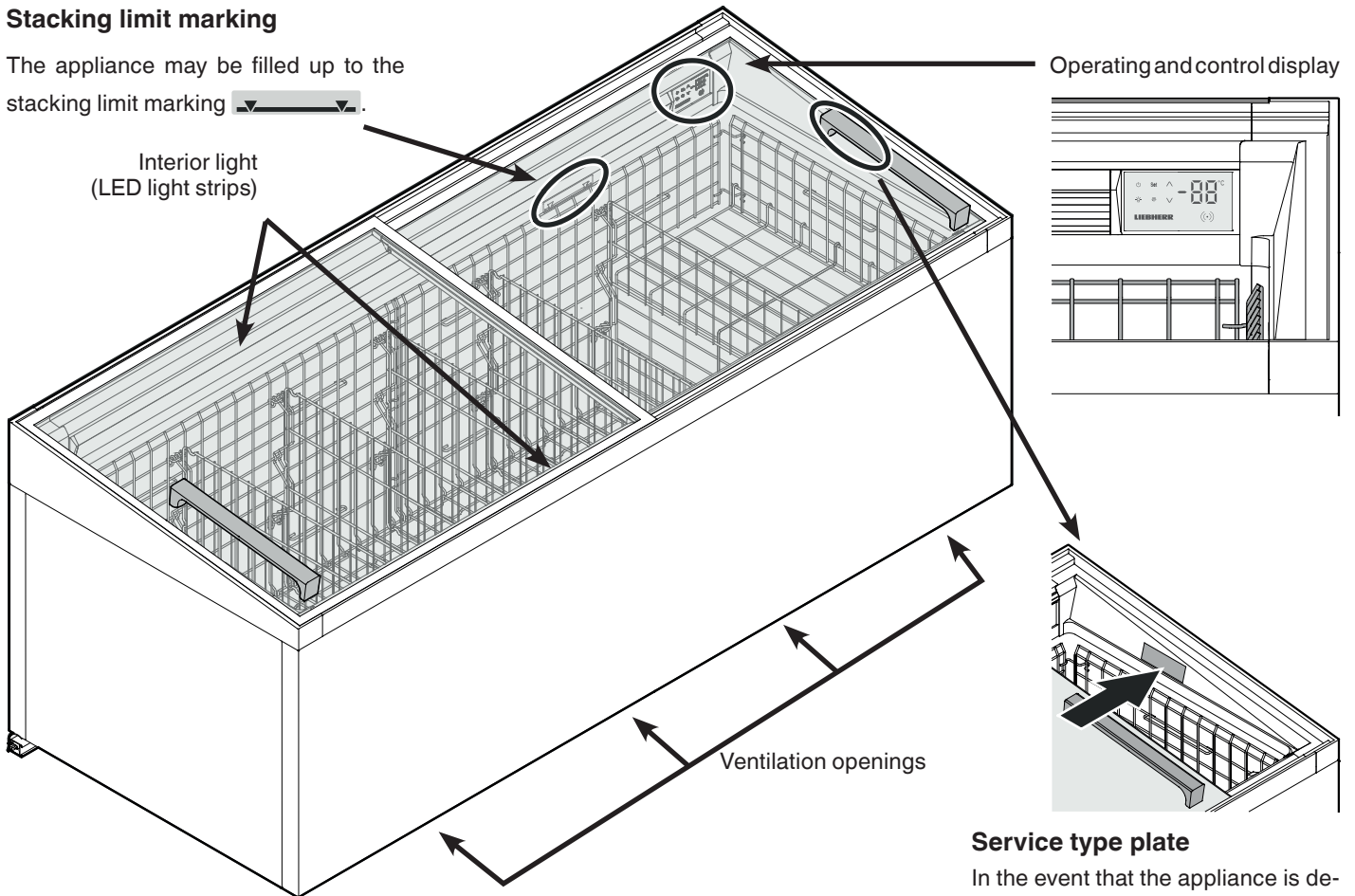

Important note

The ventilation openings on the front of the appliance must not be covered.

Service type plate

In the event that the appliance is defective, provide the customer service department with these details.

Modell: SGT 9999 Index 99/ E99
 Service-Nr./No. Service: 9999999-00
 Serien-Nr.: 99.999.999.9

Safety instructions and warnings

- If there is obvious transport damage on the appliance after it has been unpacked, contact the supplier. **Do not start the appliance.**
- Disconnect the appliance from the mains if any fault occurs. Trip the fuse upstream of the appliance. Transfer food to other appliances.
- Any repairs and work on the appliance should only be carried out by the customer service department, as unauthorised work could prove highly dangerous for the user. The same applies to changing the mains power cable.
- Do not allow naked flames or ignition sources to enter the appliance. When transporting and cleaning the appliance, ensure that the refrigerant circuit is not damaged. In the event of damage, make sure that there are no ignition sources nearby and keep the room well ventilated.
- Avoid prolonged skin contact with cold surfaces or chilled/frozen food. This could cause pain, numbness and frostbite. In the case of prolonged skin contact, protective measures should be taken, e.g. gloves should be worn.
- Do not store food whose use-by date has expired in the appliance. Eating such goods can cause food poisoning.
- Do not store explosive substances or spray cans with inflammable propellants in the appliance. Electrical components might cause leaking gas to ignite.
- Do not use electrical appliances inside the appliance.
- The appliance is designed for use in enclosed areas. Do not operate the appliance outdoors or in areas where it is exposed to splash water or damp conditions.
- The LED light strips illuminate the interior of the appliance. They are not suitable for lighting a room.
- Do not place objects on the appliance and do not place heavy loads on the sliding glass lids. The lids could be damaged.
- Do not use any mechanical devices or other artificial aids for defrosting other than those recommended by the manufacturer.
- Do not cover the ventilation openings.

Disposal instructions for packaging material

WARNING

Danger of suffocation due to packing material and plastic film!

Do not allow children to play with packaging material.

Dispose of the packaging material in compliance with current regulations.

Climate rating

The climate rating indicates at what room temperature the appliance may be operated to achieve full cooling capacity and what the maximum humidity level in the area around the appliance may be to ensure that no condensation forms on the exterior housing.

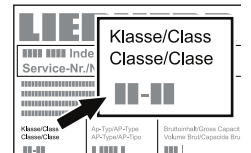

The climate rating is indicated on the type plate.

Climate rating	Max. room temperature	Max. relative humidity
3	25 °C	60 %
4	30 °C	55 %
5	40 °C	40 %
7	35 °C	75 %

The minimum room temperature at the place of installation is 10°C.

Noise emissions from the appliance

The noise level while the appliance is operating is below 70 dB(A) (relative noise level 1 pW).

The appliance complies with the relevant safety regulations and EU Directives 2014/30/EU and 2006/42/EG.

Display in indicating mode

After being commissioned by the team of technicians, the display will be in indicating mode.

The display shows the current interior temperature.

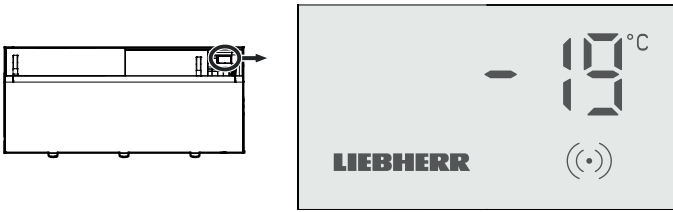

Important note

The goods must not be inserted until -18°C is shown in the display.

Setup mode

The supplied release key is required to activate setup mode.



Activating setup mode

- Touch the activation point on the display with the release key.

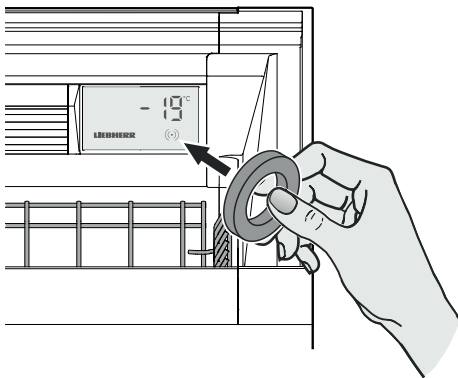

An audible warning signal will sound for 1 second.

The operating symbols are displayed.

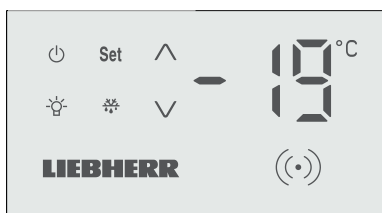

Note

If no button is pressed for 2 minutes, the electronic control system will automatically switch back to indicating mode.

Setting the real time clock



- Activate setup mode using the release key
- Press and hold the **Set** button for 5 seconds. Display = **⌚**
- Press **∨**. Display = **h**
- Press **Set**. Display = **hh ↔ 00**
- Set the hour by pressing the **∨** **∧** buttons.
- Press **Set**. Display = **mm ↔ 00**
- Set the minute by pressing the **∨** **∧** buttons.
- Press **Set**. The new setting will be saved.

The electronic control system will switch back to indicating mode.

- Press and hold the **Set** button for 5 seconds. Display = **⌚**
- Press **∨**. Display = **y**
- Press **∨**. Display = **dy**
- Press **Set**. Display = **yr ↔ 00**
- Set the year by pressing the **∨** **∧** buttons.
- Press **Set**. Display = **mm ↔ 00**
- Set the month by pressing the **∨** **∧** buttons.
- Press **Set**. Display = **dy ↔ 00**
- Set the day by pressing the **∨** **∧** buttons.
- Press **Set**. The new setting will be saved.

The electronic control system will switch back to indicating mode.

Changing the temperature setting

The desired temperature is set to -18°C.

It may be set to -23°C.

Depending on the customer's version, different control areas may be blocked or released.

Proceed as follows:

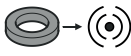
- Activate setup mode using the release key 



The current temperature inside the appliance is displayed.

- Press  → **-23** flashes.
- Press **Set** → The new setting will be saved.

The electronic control system will switch back to indicating mode.

Note

Repeat these steps to reset the temperature to -18°C.

Press the  button instead of the  button.



Activating the defrost function manually

The appliance defrosts automatically.

Increased frost may form on the interior container in high ambient temperature and humidity.

In this case, activate the defrost function manually.

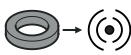
Proceed as follows:

- Activate setup mode using the release key 
- Press  →  flashes.
- Press **Set** The defrosting process will be started.

The electronic control system will switch back to indicating mode. The LED  will be lit until the defrosting process is finished.





Interior light

(depending on options)

Switch the interior light on or off as required.

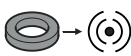
Switching on the interior light

- Activate setup mode using the release key 
- Press  →  flashes.
- Press **Set** The interior light is switched on.

Note

Repeat these steps to switch off the interior light again.

Malfunctions

The release key symbol (dot) will flash in the event of a malfunction or if the appliance is defective.



Proceed as follows::

- Activate setup mode using the release key 

Either a **flashing temperature display** or an **error code** will appear in the display.

Action to take if the temperature display is flashing

- First check whether the appliance lids are closed.

If the temperature falls after closing the lids, no further action is required.

If no drop in temperature is apparent after approx. 10 minutes:

- Transfer the goods immediately to other appliances.
- Notify the customer service department.

Action to take if an error code is displayed

Error code F1, F2, F4 or F5

The temperature sensor in the appliance is defective.

Action

- Notify the customer service department.

The goods can be left in the appliance since the temperature is maintained by the appliance being in emergency mode.

Error code Ht

The temperature inside the appliance is too high (warm).

Action

- Transfer the goods immediately to other appliances.
- Notify the customer service department.



Error code nA

A mains failure has occurred.

Action

- Press **Set** → The maximum (warmest) temperature during the mains failure is displayed.
- Decide whether the goods can be used depending on the level of the temperature rise.

Switching the appliance off

- Activate setup mode using the release key 
- Press and hold the  button for 5 seconds.

The temperature display will go out.

The interior light will go out.

The release key symbol (dot) will still be lit to show that the appliance is connected to the electricity supply.



Important note

If the appliance has been switched off using the  button, the refrigeration system is switched off but the appliance has not been fully disconnected from the mains.

Before cleaning, always disconnect the appliance from the mains. Switch off the fuse.

Switching the appliance on

- Activate setup mode using the release key 

Press the  button.

The display will show the current temperature inside the appliance.



Cleaning

The appliance may only be cleaned by authorised, trained personnel.

Clean the appliance at least twice per year.

Do not use steam cleaning equipment to clean the appliance. This may cause damage or injuries.

Do not use acidic, highly alkaline or abrasive cleaning products.

Do not use chemical solvents.

Do not use abrasive cleaning cloths or sponges.

Use a damp cloth only around the electronic display. Ensure that no moisture gets into the electrical components.

Before cleaning, always disconnect the appliance from the mains. Switch off the fuse.

Removing the lids

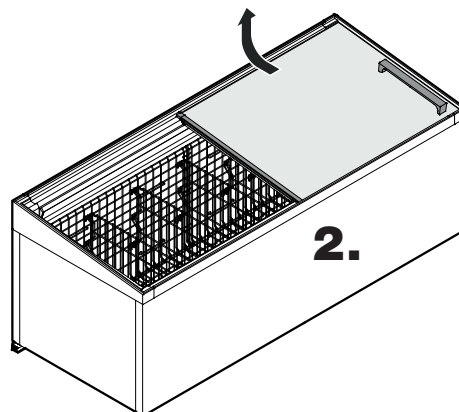
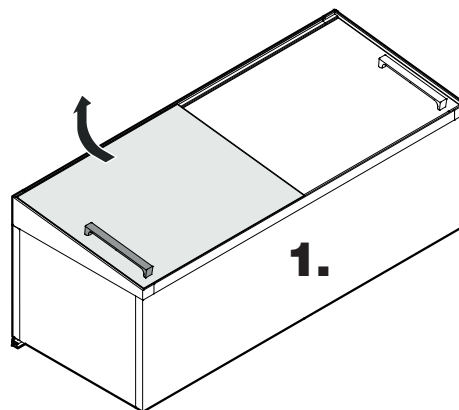

- Clean the glass surfaces with glass cleaner. Clean the handles and plastic strips with water and detergent. Then dry the lids.

Fitting the lids

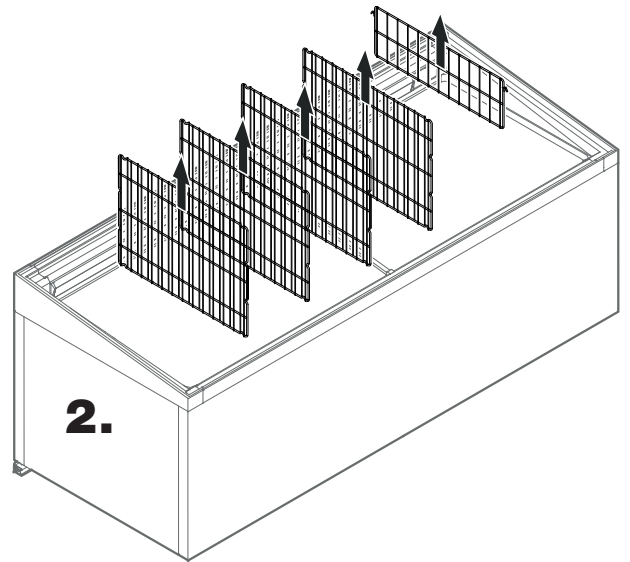
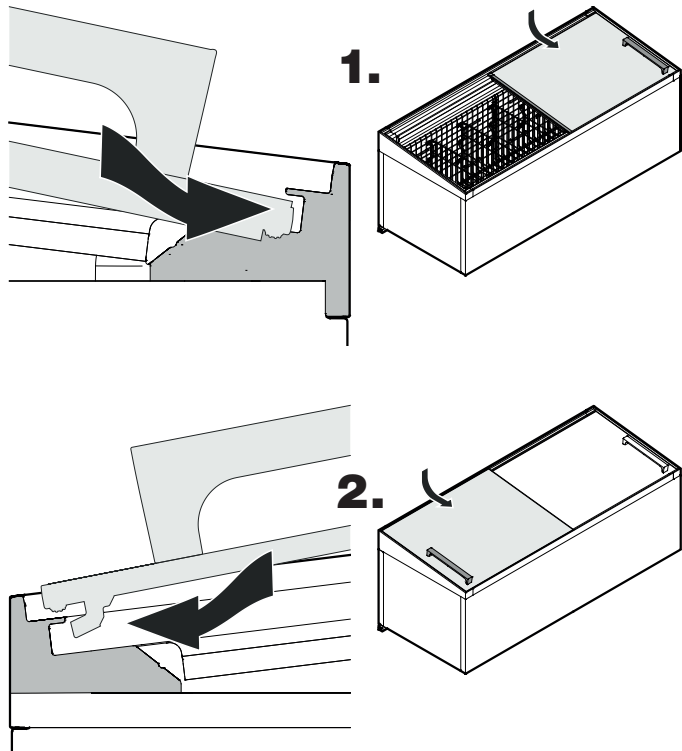

Removing the separators if there is a shortage of space due to display units above the appliance

- Unhook one of the support brackets,
- Place it on the separator,
- Swivel the separator to the side.

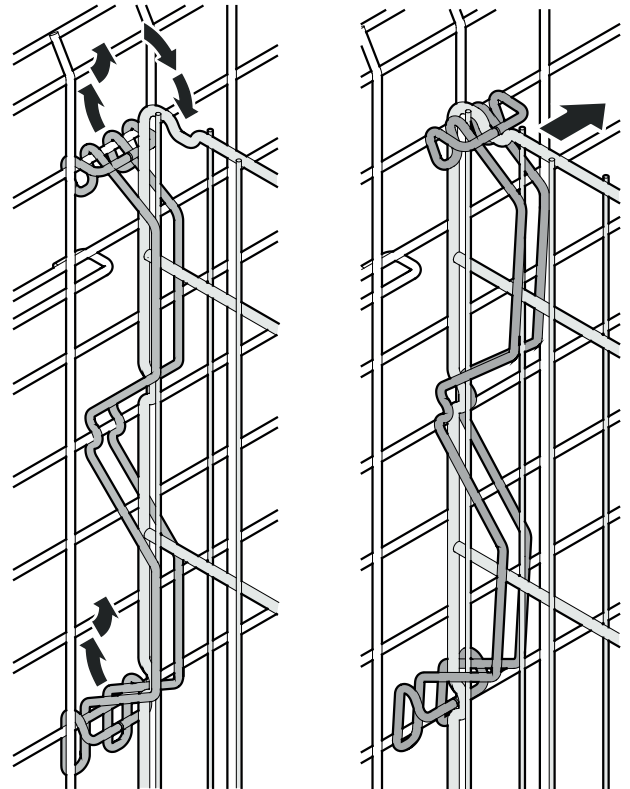

Removing the grids

- Remove the grids in the sequence shown below.

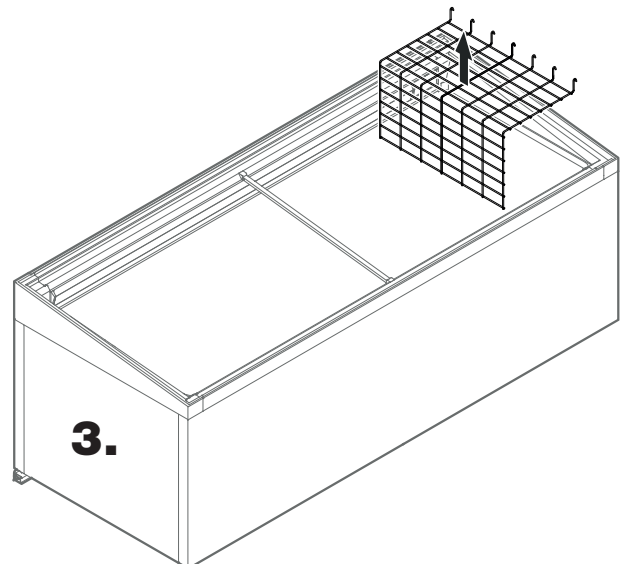
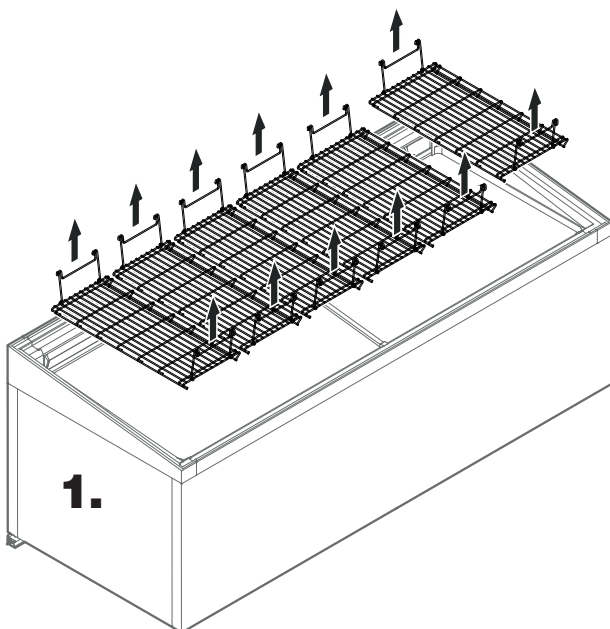

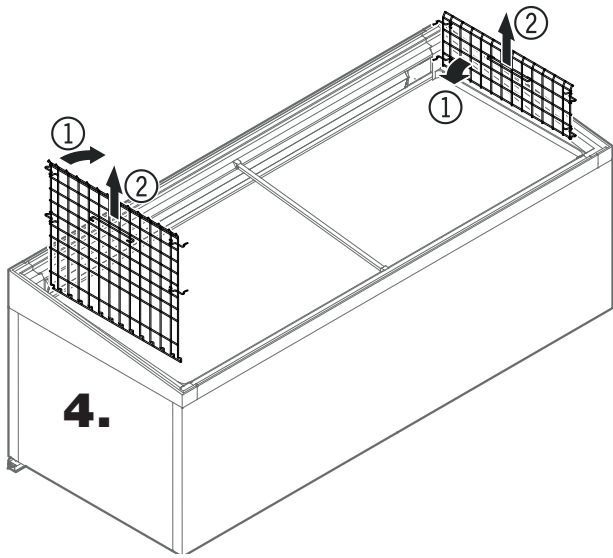

4.

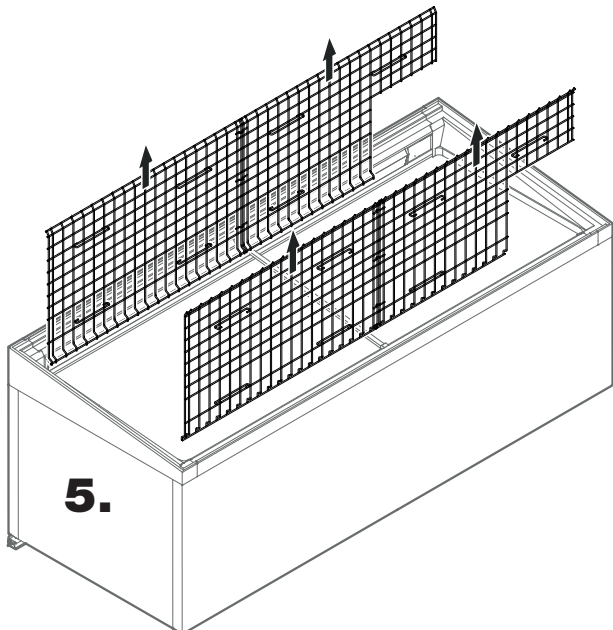

5.

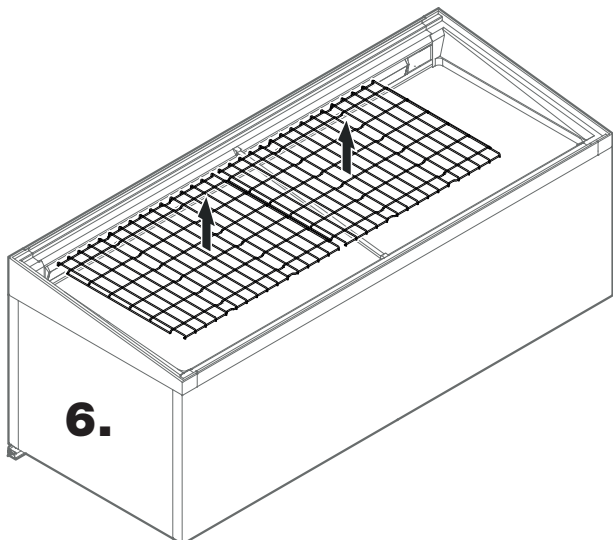

6.

Cleaning the interior

- Remove the frost from the interior container walls using the supplied ice scraper.
- Clean the interior container walls.
- Clean the defrost drain gully.

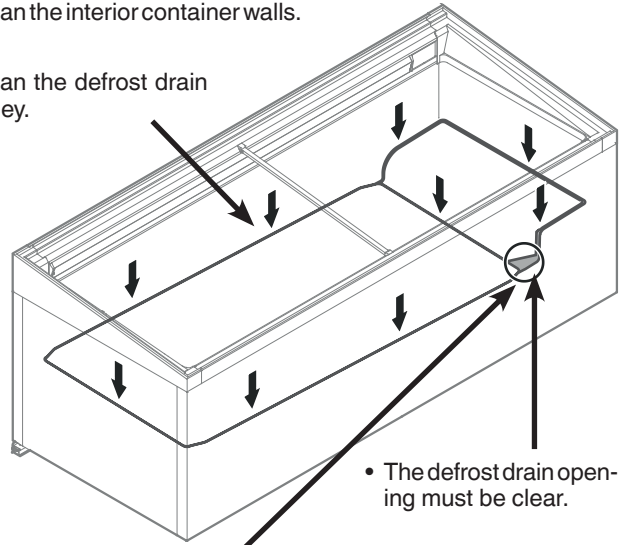
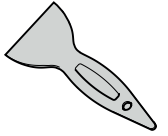

• The defrost drain opening must be clear.

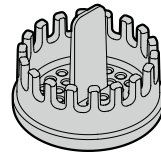

• Clean the filter.

- Dry the interior of the appliance.

Inserting the grids

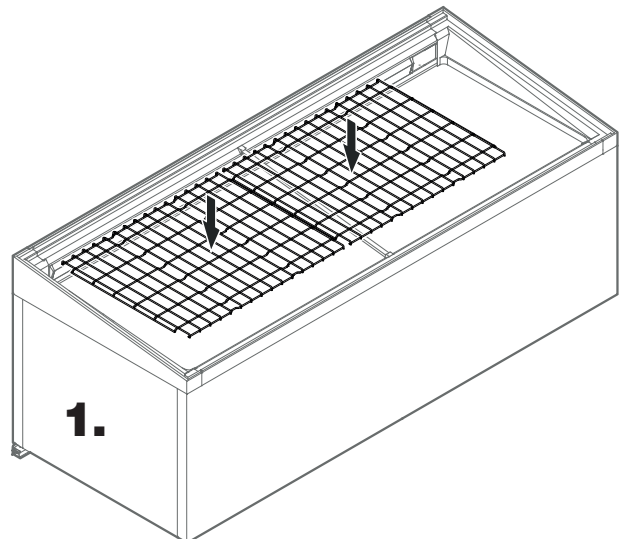

1.

Important note

The storage grids must be fitted.

No goods may be placed on the baseplates.

- Clean the grids with water and detergent, then dry them.

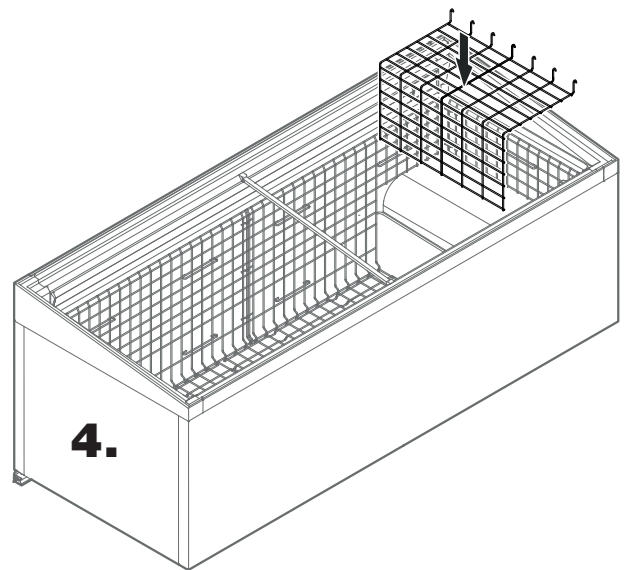
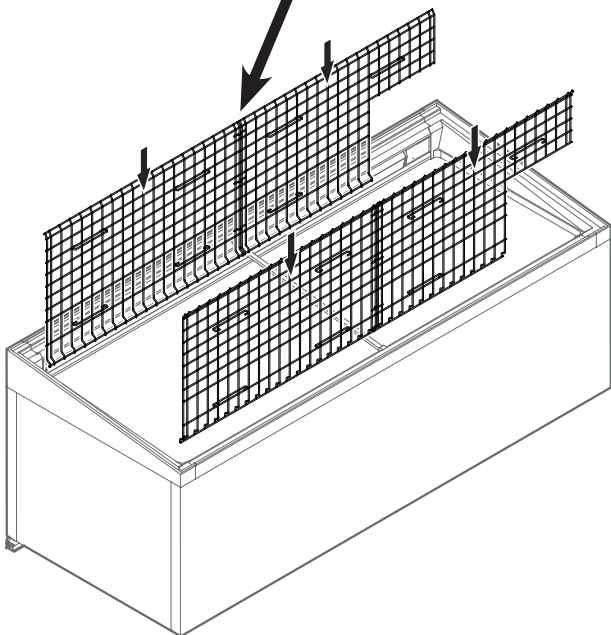
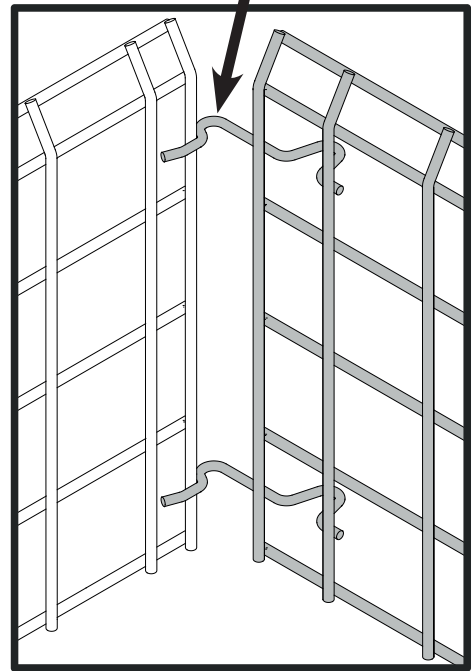
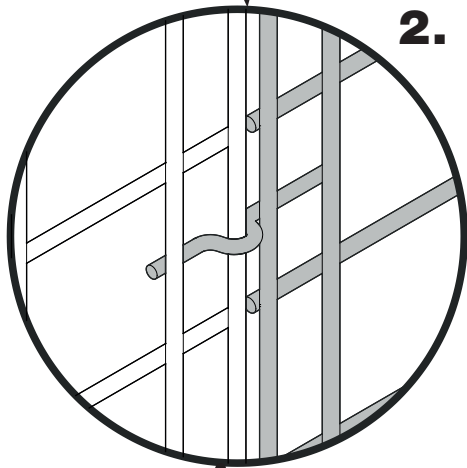
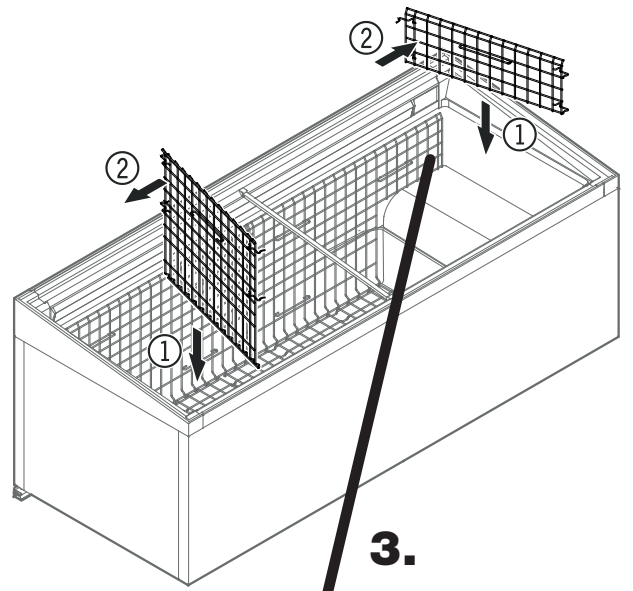
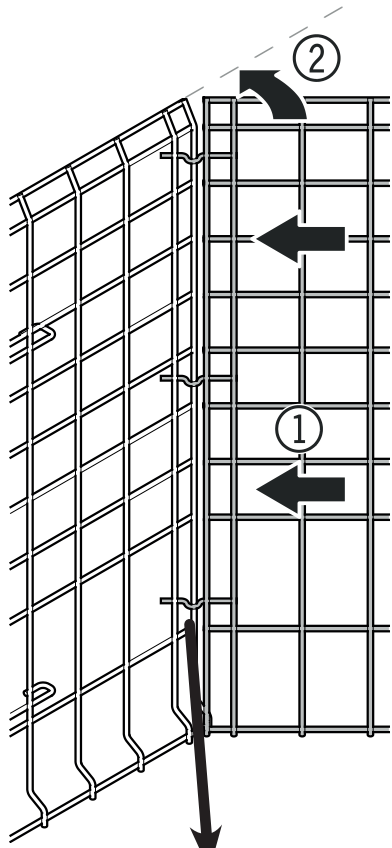

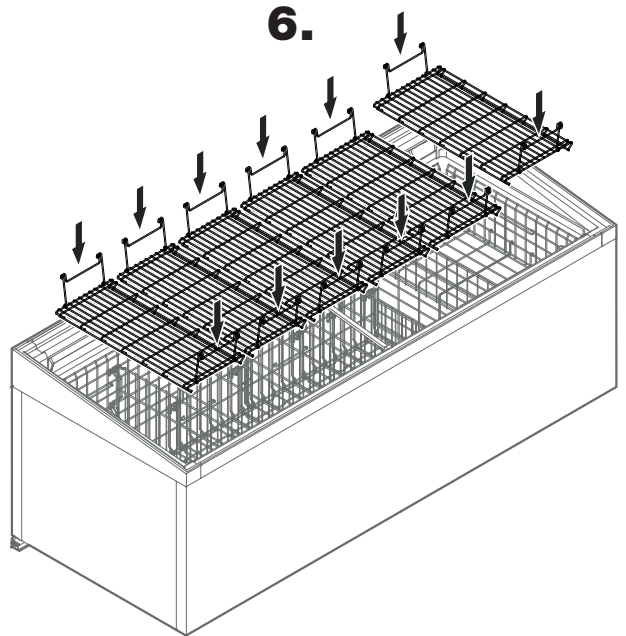
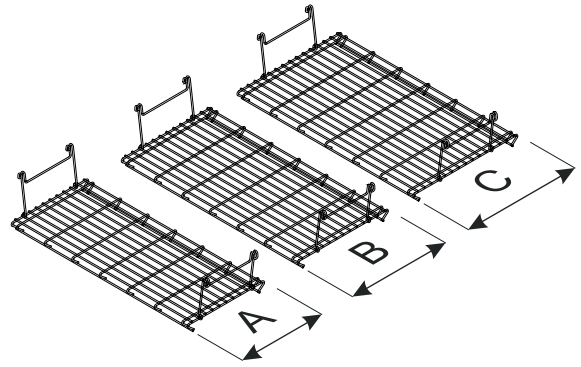
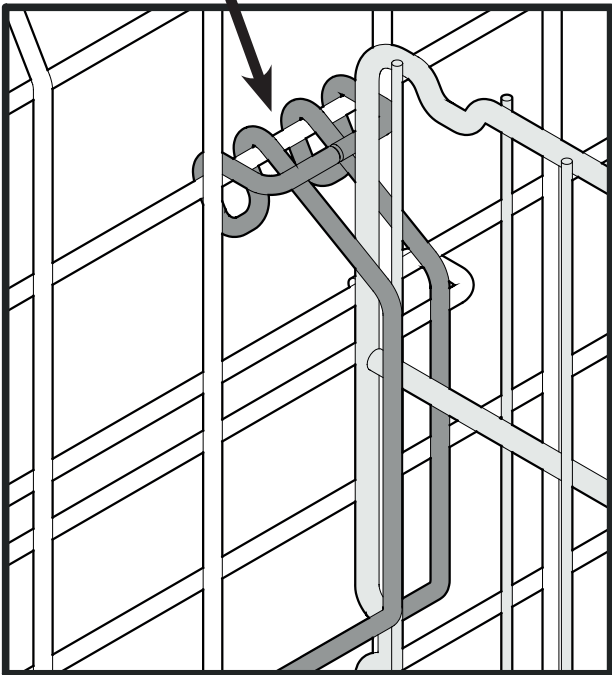
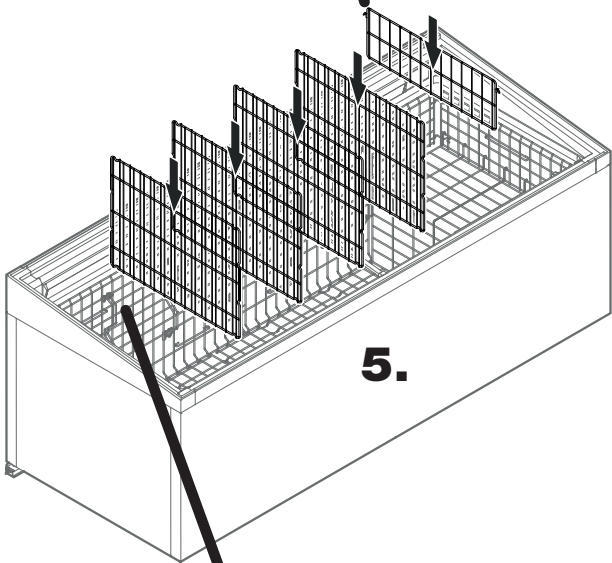
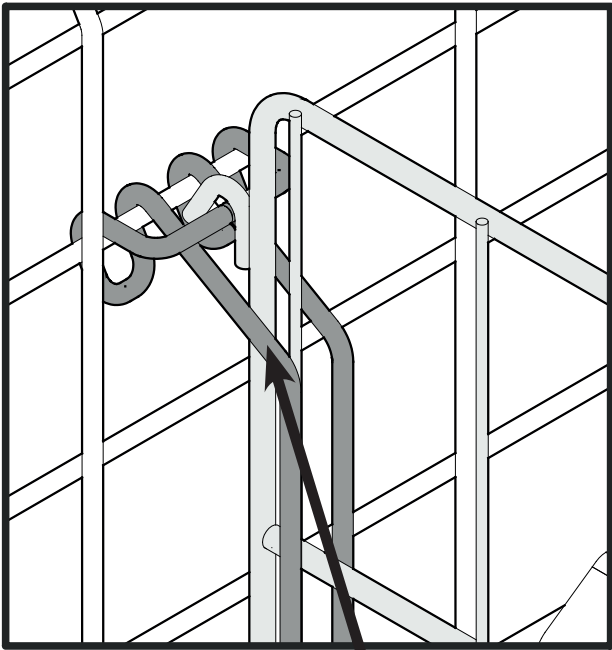

NOTICE

Excessive load!

Damage to property.

The maximum load per intermediate grid is 31 kg.

Width of intermediate grid	mm
A	280
B	330
C	380

Chest width [mm]	[No. of parts] x [width of intermediate grid]
1800	3x A
	2x B
2100	4x A
	2x B
	1x A 4x C
2500	5x A
	1x C
	1x C 4x A
	2x B
	5x C
	1x A

Other combinations are possible

Repositioning the support brackets

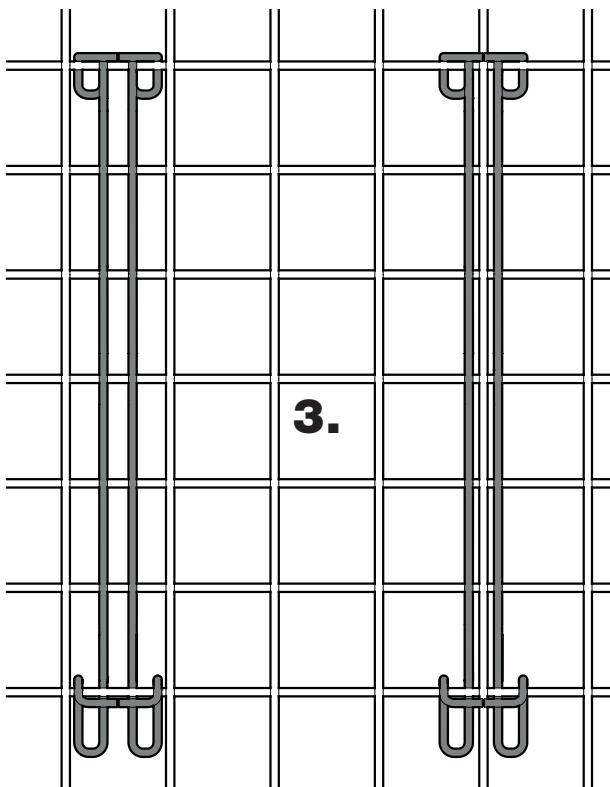
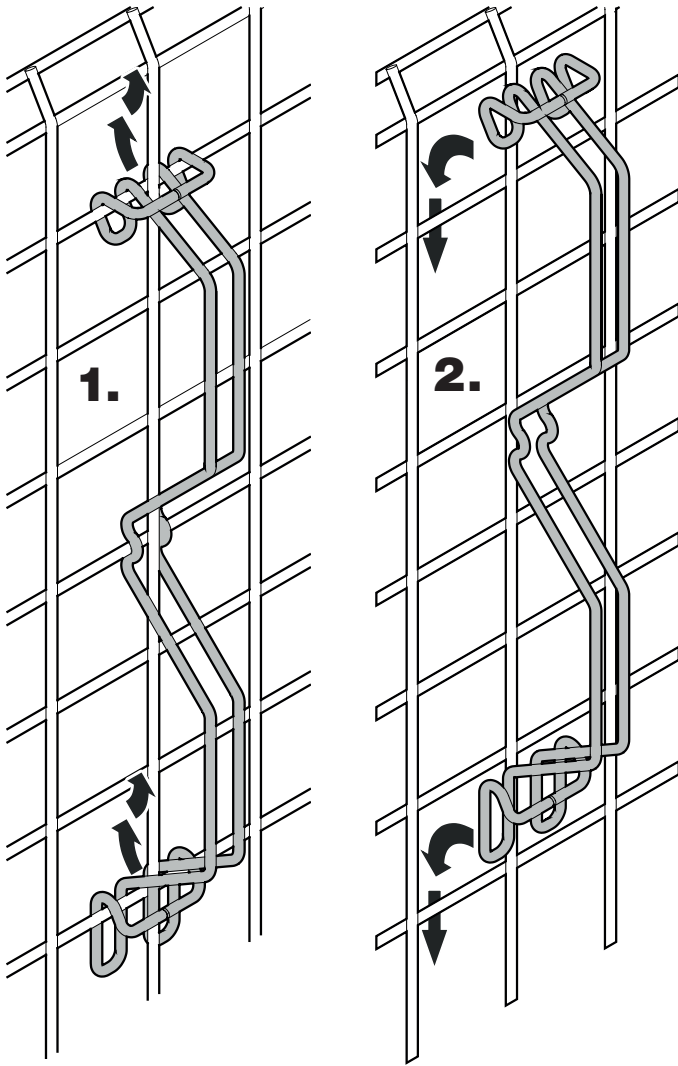

Customer service

If the appliance suffers a malfunction:

- Transfer the stored goods to other appliances.
- Switch off the appliance.
See section entitled **Switching the appliance off**.
- Disconnect the appliance from the mains > switch off the fuse.
- Notify the customer service department quoting the appliance details.

The appliance details are shown on the service type plate.

The position of the service type plate is shown in the section entitled **Description of the appliance**.

Shutting down the appliance

If the appliance is shut down for a lengthy period of time:

Switch off the fuse.

Clean the appliance and leave the lids open to prevent odour formation.

Disposal notes

The appliance contains reusable materials and should be disposed of properly - not simply with unsorted household refuse.



Appliances which are no longer needed must be disposed of in a professional and appropriate way, in accordance with the current local regulations and laws.

When disposing of the appliance, ensure that the refrigerant circuit is not damaged to prevent uncontrolled escape of the refrigerant it contains (data on type plate) and oil.



Liebherr Hausgeräte Lienz GmbH

Dr.-Hans-Liebherr-Strasse 1

A-9900 Lienz

Österreich

www.liebherr.com

