

---

# Our accessories make the difference.

---

Options for more benefit.

## **LIEBHERR**

Accessories for Truck Mixer generation 05



# Customised truck mixer

With our innovative truck mixer configurator, creating your dream vehicle has never been easier. We have developed a user-friendly platform that allows you to make all the important decisions with ease. Here are some of the outstanding features:

## Simple operation system

Our configurator is easy to use, even for technical amateurs. The intuitive user interface guides you effortlessly through the configuration process.

## Graphical representation

See what your vehicle will look like from all sides in 3D. This way you can ensure that it meets your requirements.

## Payload calculation

Our configurator calculates the payload in real time. Enter the desired drum size to get the payload in cubic metres of concrete straight away.

## Key information indicators

If more extensive options are selected, all of the relevant details are displayed automatically. This way you won't miss any important information, allowing you to make informed decisions.

## Huge range of accessories

Our configurator features an extensive and clearly organised range of accessories. Browse through the various categories and select suitable options.

## Personalised design

You can also use the configurator to customise the vehicle's look. Choose from a variety of colours and designs to ensure that your vehicle reflects your personal preferences.



Select your country for pre-selections, check the range of accessories and save your individual configuration - even without a request.

Configure your vehicle online at:  
[www.fahrmischer-konfigurator.de](http://www.fahrmischer-konfigurator.de)

# Platform solution: Accessories perfectly positioned

With its platform solution, Liebherr enables you to take all your accessories and tools with you in the vehicle in the easiest possible way. The customer has complete flexibility in terms of positioning and is able to react to the driver's individual requirements.

Everything is safely stowed or secured while the vehicle is on the move. This makes day-to-day work easier.

## The Liebherr platform solution

ensures that the driver can work safely and flexibly every day.



# Everything you could wish for



Lightweight extension chute



Steel folding chute with guard



Lightweight folding chute with guard



End chute



Reducing chute

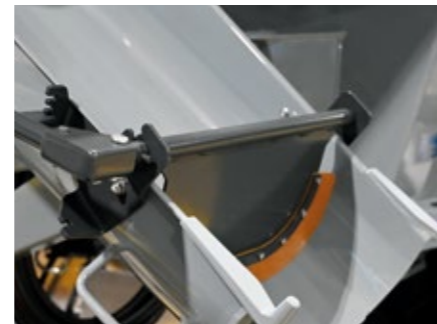

Swing flap



Hydraulically adjustable chute: mechanical-hydraulic or fully hydraulic



Hoop guard for chutes

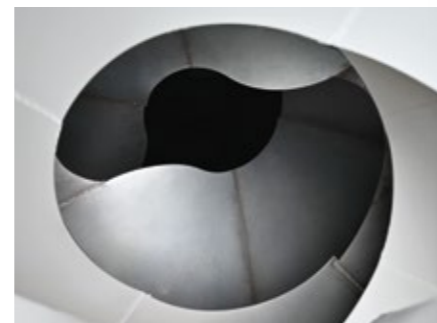

Capacity plates for greater transport safety, especially for liquid consistencies



Admixture tank, air pressed



Forming oil nozzle



Admixture tank pressureless



Litronic EMC with driver's cab control



Stainless steel housing for Litronic EMC



Swivelling control unit



Storage box small made of plastic



Storage box big made of plastic



Storage box big made of stainless steel

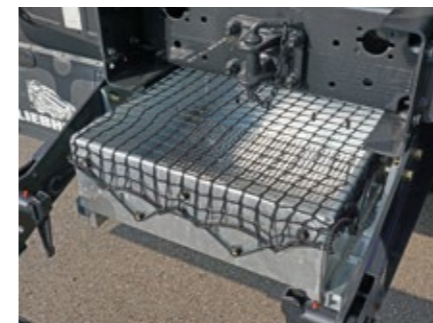

Heavy load cage with net



Handlebar at the rear



Handlebars on the sliding ladder



"Awaywashbox" wash-out box



Emergency discharge cable set

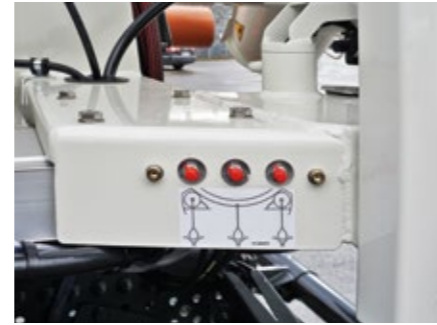

Central lubrication point

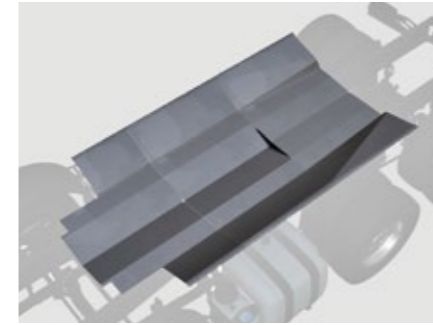

Alu frame cover

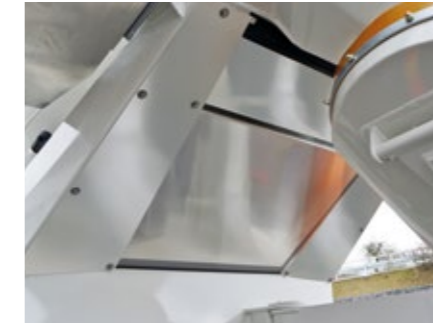

Rear drum pedestal cover incl. rubber seal on discharge hopper



Operator protective roof



Reversing camera and LED headlight at the rear come as standard (DIN-EN 12609)



360° degree camera



Up to four additional LED headlights possible



Rear wheel mudguard in aluminium



Drum segment lock (3/4 cover), hydraulically operated



Feeding hopper, mechanically swivelled to the side



Compressed air connection at the rear



Water connection on both sides

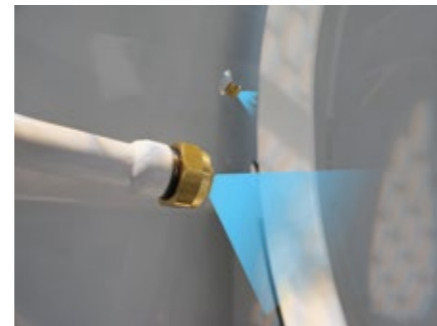

Cleaning nozzle at drum discharge



Pipe holder



Toolholder for trowel



Step on underrun protection on both sides



Water meter



Pressure gauge



LWCS water telematics



ZF gear box P 5300 / P 7300



ZF gear box CML



Reflectors above rear lights

# We are here for you!

Personal. Capable. Reliable.



Concrete pumps



Mixing plants



Truck mixers



Conveyor belts



Measuring technology



Mixing systems



Concrete recycling systems

## Your powerful partner.

- Delivery and instruction by experienced service technicians
- Worldwide service network with over 90 service centres
- Technical support worldwide
- Fast availability of spare parts
- Professional maintenance and services

**Liebherr-Mischtechnik GmbH** • Postbox 145 • 88427 Bad Schussenried, Germany  
+49 7583 949-0 • [www.liebherr.com](http://www.liebherr.com) • E-Mail: [info.lmt@liebherr.com](mailto:info.lmt@liebherr.com)

**Get your  
contact**

