



User Guide

Quality, Design and Innovation



home.liebherr.com/fridge-manuals



LIEBHERR

Contents

1	The appliance at a glance.....	3	6.2.20	Software	40
1.1	Included in delivery.....	3	6.2.21	Defrosting	40
1.2	Overview of appliances and equipment.....	3	6.2.22	Data download / Datalogging.....	41
1.3	Special features.....	4	6.2.23	Sensor calibration	41
1.4	Range of appliance use.....	4	6.2.24	Temperature alarm	42
1.5	Sound emission of the appliance.....	5	6.2.25	Door alarm	44
1.6	Conformity.....	5	6.2.26	Light alarm	45
2	General safety instructions.....	5	6.2.27	Alarm simulation	46
3	Functionality of the Touch & Swipe display.....	7	6.2.28	Alarm log	46
3.1	Navigation and symbol explanation.....	8	6.2.29	Alarm forwarding	47
3.2	Menus.....	8	6.2.30	Demo mode	47
3.3	Sleep mode.....	9	6.2.31	Resetting to factory settings	48
4	Start-up.....	9	6.3	Messages.....	48
4.1	Setup conditions.....	9	6.3.1	Warnings.....	48
4.2	Appliance dimensions.....	10	6.3.2	Reminders.....	51
4.3	Transporting the appliance.....	10	7	Equipment.....	52
4.4	Unpacking the appliance.....	10	7.1	Safety lock.....	52
4.5	Installing the door handle.....	11	7.2	Safety lock.....	52
4.6	Mounting the anti-tipping device.....	11	7.3	Sensors.....	52
4.7	Setting up the appliance.....	12	7.4	Sensor info	53
4.8	Leveling out the appliance.....	12	7.5	Interfaces.....	53
4.9	Setting up multiple appliances.....	12	8	Maintenance.....	54
4.10	After setup.....	13	8.1	Maintenance schedule.....	54
4.11	Disposal of packaging.....	13	8.2	Defrosting the appliance.....	56
4.12	Reversing the door opening direction.....	13	8.3	Cleaning the appliance.....	56
4.13	Aligning the door.....	25	8.4	Replacing appliance battery.....	58
4.14	Connecting the appliance to the power supply.....	26	9	Customer support.....	58
4.15	Switching on the appliance (first use).....	26	9.1	Technical data.....	58
5	Storage.....	27	9.2	Technical malfunction.....	59
5.1	Information regarding storing items.....	27	9.3	Customer Service.....	60
6	Use.....	27	9.4	Type plate.....	60
6.1	Control and display elements.....	27	10	Shutting down.....	61
6.1.1	Status display.....	28	11	Disposal.....	61
6.1.2	Display symbols.....	28	11.1	Preparing the appliance for disposal.....	61
6.1.3	Acoustic signals.....	29	11.2	Disposing of the appliance in an environmentally friendly manner.....	61
6.2	Appliance functions.....	29	12	Additional information.....	61
6.2.1	Notes on the appliance functions.....	29	13	Quick Start Guide for everyday use.....	63
6.2.2	Switching appliance on and off	29			
6.2.3	Switching temperature zone off and on	29			
6.2.4	Temperature	30			
6.2.5	Temperature recording	31			
6.2.6	Lighting	32			
6.2.7	Settings menu access protection	32			
6.2.8	Access codes.....	33			
6.2.9	Maintenance interval reminder	34			
6.2.10	Language	34			
6.2.11	Date and time	35			
6.2.12	Temperature unit	35			
6.2.13	Display Brightness	36			
6.2.14	Alarm Sound.....	36			
6.2.15	Key Sound.....	36			
6.2.16	WiFi connection	37			
6.2.17	LAN connection	38			
6.2.18	Appliance information	39			
6.2.19	Operating hours	39			







Congratulations on the purchase of your new appliance. With this purchase, you have chosen all the advantages of the latest refrigeration technology, guaranteeing you a high-quality appliance with a long life span and high operating safety.

The equipment of your appliance gives you the highest level of day-to-day ease of operation.

Together we are making an active contribution to the conservation of our environment by purchasing this appliance which is manufactured in an environmentally friendly process with the use of recyclable materials.

We hope you enjoy your new appliance.

The manufacturer is constantly working to improve all types and models. Therefore, please be aware that we reserve the right to make changes to the shape, equipment and technology.

Symbol	Explanation
	Read instructions Please read the information in these instructions carefully to understand all of the benefits of your new appliance.
	Additional information online The digital manual with supplemental information can be found online by scanning the QR code on the front page of this manual or by entering the service number at home.liebherr.com/fridge-manuals .
	Check appliance Check all parts for transport damage. If you have any complaints, please contact your agent or customer service.
	Differences These instructions apply to a range of models, so there may be differences. Sections that apply to certain models only are indicated by an asterisk (*).
	Instructions and results Instructions are marked with a ▶. Results are marked with a ▷.
	Videos Videos about the appliances are available on the YouTube channel of Liebherr-Hausgeräte.

Open-source licenses:

The appliance includes software components that make use of open-source licenses. You can find information on the open-source licenses to be used here: home.liebherr.com/open-source-licenses

These operating instructions apply to:

- SCFvh 4002
- SCFvh 4032

1 The appliance at a glance

1.1 Included in delivery

Check all parts for transport damage. If you have any issues, please contact your dealer or Customer Service. (see 9.3 Customer Service)

The delivery contains the following parts:

- Freestanding appliance
- Equipment *
- Installation materials *
- Operating instructions
- Warranty documents
- Quality certificate *

- Power cable
- Wall fastening kit

1.2 Overview of appliances and equipment

SCFvh 4002

SCFvh 4032

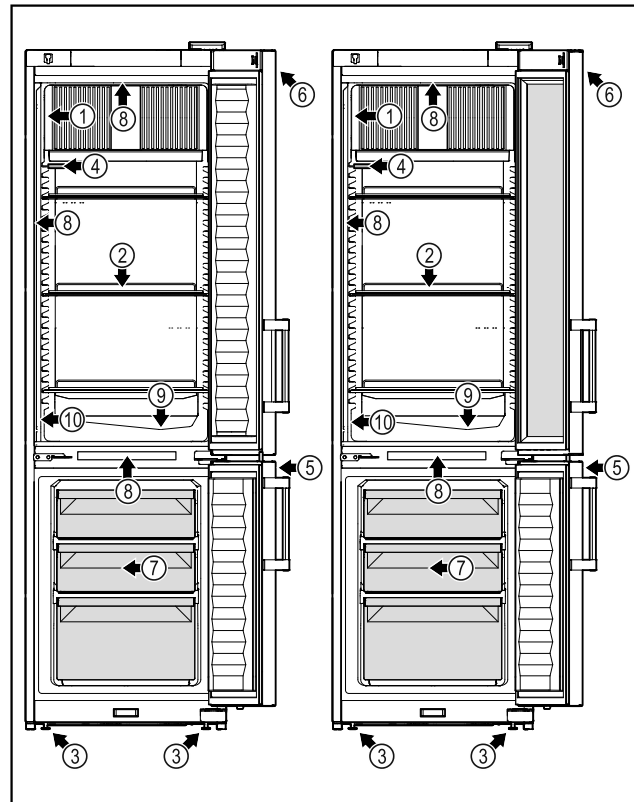
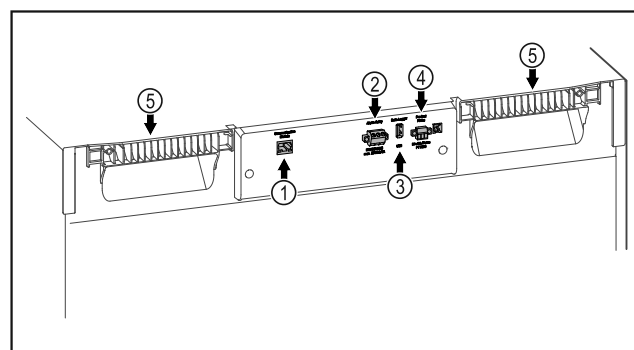

Fig. 1 Example illustration

Equipment

- | | |
|---------------------|--|
| (1) Type plate | (6) Control elements and temperature display |
| (2) Grid shelves | (7) Freezer drawer |
| (3) Adjustable feet | (8) Interior lighting |
| (4) P sensor | (9) Defrost drain |
| (5) Lock | (10) Safety thermostat sensor |



The appliance at a glance

Fig. 2 Example illustration

Equipment

- (1) LAN/WiFi interface*
- (2) Potential-free alarm output
- (3) USB interface
- (4) Connection for P sensor
- (5) Carrying aid

1.3 Special features

Note

Accessories are available from the Liebherr Service Center. The address for your respective country can be found on the back of the instructions.

SmartModule

The appliance is equipped with a SmartModule. This is a WiFi and LAN interface for the connection between the appliance and an external documentation and alarm system such as Liebherr SmartMonitoring. Liebherr SmartMonitoring Dashboard is not available in all countries. Check for availability via the QR code (see 6.2.16 WiFi connection) and entering your model.

Retrofitting drawers

Temperature qualification is required when retrofitting drawer systems in Liebherr refrigerators/freezers where these are used for temperature-sensitive materials such as chilled drugs and refrigerated products which are subject to specific standards requirements. Retrofitting drawers in Liebherr refrigerators/freezers can result in the goods stored becoming spoiled or damaged. The retrofitting must therefore be completed exclusively by authorized service providers from the manufacturer of the refrigerator/freezer.

1.4 Range of appliance use

Intended use

This laboratory refrigerator/freezer is suitable for professional storage of products at temperatures between 3 °C (38 °F) and 16 °C (60 °F) in the refrigerator compartment and between -9 °C (15 °F) and -30 °C (-22 °F) in the freezer compartment.

Typical products to be stored include research samples, reagents, laboratory inventory etc.

Storage of temperature-sensitive substances requires the use of an independent, permanently monitored alarm system. This alarm system must be designed such that a responsible person can record every alarm condition to be able to take suitable measures.

Foreseeable incorrect use

Do not use the appliance for the following applications:

- Storage and cooling of:
 - Chemically unstable, flammable or corrosive substances
 - Blood, plasma or other body fluids for the purpose of infusion, application or introduction in the human body.
- Use in potentially explosive atmospheres.
- Use outdoors or in areas exposed to dampness and splashing water.
- Used in a residential spaces because suitable protection of radio reception cannot be ensured in these environments.*

Any misuse of the appliance may result in damage to or spoilage of stored goods.

Climate classes

The climate class for your appliance is printed on the identification plate.

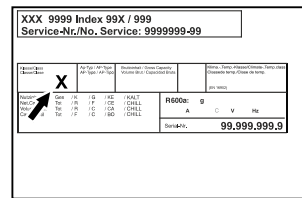

Fig. 3 Type plate

(X) This climate class indicates the environmental conditions in which the appliance can be operated safely.

Climate class (X)	max. room temperature	max. rel. humidity
7	35 °C (95 °F)	75%

Note

The minimum permitted room temperature at the setup location is 10 °C (50 °F).

The interior temperature of the appliance never exceeds the ambient temperature at the setup location.

Slight condensation may form on the glass door on the side walls if the boundary conditions are exceeded.

1.5 Sound emission of the appliance

The A-weighted emission sound pressure level during operation of the appliance is below 70 dB(A) (sound power rel.1 pW).

1.6 Conformity

The refrigerant circuit has been tested for leaks. The appliance complies with the relevant safety regulations as well as the corresponding directives.

2 General safety instructions

Please keep these operating instructions in a safe place so you can refer back to them at any time.

If you pass the appliance on, please hand these operating instructions to the new owner. Read and follow these instructions. They contain safety information which is important for safe and problem-free installation and operation. Always read and follow the safety information.

Dangers for the user:

- This appliance may only be used by specialist and laboratory personnel who have been trained for this purpose and are familiar with all the safety measures for work in a laboratory. Children and persons with impaired physical, sensory or mental abilities or with a lack of experience and knowledge may not commission or operate this appliance.
- **IMPORTANT:** The power plug must be easily accessible so that the appliance can be disconnected from the mains quickly in an emergency. It must not be behind the back of the appliance.
- Always hold the plug of the cable when disconnecting the appliance from the power supply. Do not pull on the cable.
- Remove the plug or disconnect via the fuse if there is a malfunction.
- **WARNING:** Do not damage the power cable. Do not operate the appliance with a faulty power cable.
If the supply cord is damaged, it must be replaced by the manufacturer, its service agent or similarly qualified persons in order to avoid a hazard. For Plug and Play connec-

tion cables, the exchange may be carried out by the customer.

- **WARNING:** Multi-sockets/power distributors and other electronic appliances (such as halogen transformers) may not be placed and operated behind appliances.
- **WARNING:** Do not block the ventilation openings in the appliance housing or in the installation housing.
- Repairs and work on the appliance may only be carried out by Customer Service or other specifically trained qualified personnel.
- Always follow the instructions when assembling, connecting and disposing of the appliance.

Risk of fire:

- The refrigerant contained within the appliance (specifications on the type plate) is environmentally friendly, but flammable. Leaking refrigerant can ignite.
 - **WARNING:** Do not damage the refrigerant circuit.
 - Do not handle ignition sources inside the appliance.
 - **WARNING:** Do not use electrical appliances inside the food storage compartments of the appliance, unless they are of the type recommended by the manufacturer.
 - If refrigerant leaks: Remove naked flames or ignition sources located near the area of the leak. Ventilate the room well. Contact Customer Service.
- Do not operate the appliance near explosive gases.
- Do not store or use gasoline or other flammable gases and liquids near the appliance.
- Do not store explosive substances such as aerosol cans with a flammable propellant in this appliance. You can recognize such spray cans by the printed list of contents or by a flame symbol. Any leaking gases can be ignited by electrical components.
- Keep lit candles, lamps and other objects with naked flames away from the appliance so they do not cause a fire.
- Alcoholic liquids or other containers holding alcohol must always be tightly sealed for storage purposes. Any leaking alcohol can be ignited by electrical components.

General safety instructions

Risk of falling or toppling over:

- **WARNING:** To avoid a hazard due to instability of the appliance, it must be fixed in accordance with the instructions.
- Do not stand on the base, drawers, doors etc. or use them as improper supports.

Danger of frostbite, feeling of numbness and pain:

- Avoid prolonged skin contact with cold surfaces or chilled/frozen food or take protective measures, e.g. wear gloves.

Risk of injury and damage:

- **WARNING:** Do not use mechanical devices or other means to accelerate the defrosting process, other than those recommended by the manufacturer.
- **WARNING:** Risk of injury due to electric shock! There are live electrical parts under the cover.
Have the LED interior lighting replaced or repaired only by Customer Service or other suitably trained professionals.
- **NOTICE:** The appliance must only be operated using original manufacturer accessories or accessories from other providers approved by the manufacturer. The user bears the risk of using accessories which are not approved.

Risk of crushing:

- Do not reach into the hinge when opening and closing the door. Fingers may get trapped.

California Proposition 65:

- **WARNING:** This product can expose you to chemicals including Diisononyl Phthalate (DINP), which is known to the State of California to cause cancer, and Diisodecyl Phthalate (DIDP), which is known to the State of California to cause birth defects or other reproductive harm. For more information, go to www.P65Warnings.ca.gov

FCC warning:

- Changes or modifications not expressly approved by the party responsible for compliance could void the user's authority to operate the equipment.

FCC note:

- This appliance has been tested and found to comply with the limits for a Class B digital device, pursuant to part 15 of the FCC Rules. These limits are designed to provide reasonable protection against harmful interference from an installation in residential areas. This appliance generates, uses and can radiate radio-frequency energy and, if not installed and used in accordance with the instructions, may cause harmful interference to radio communications. However, there is no guarantee that interference will not occur in a particular installation.

If this appliance does cause harmful interference to radio or television reception, which can be determined by switching the appliance on and off, the user should try to correct the interference by one or more of the following measures:

- Reorient or relocate the receiving antenna.
- Increase the distance between the appliance and receiver.
- Connect the appliance to an outlet on a circuit different from that to which the receiver is connected.
- Consult the dealer or an experienced radio/TV technician for help.

FCC Radio Frequency Exposure Statement:

- This appliance is found to comply with FCC radio frequency (RF) exposure limits set for an uncontrolled environment. This transmitter must not be set up or operated in conjunction with another antenna or another transmitter.
- This appliance should be installed and operated at a minimum separation distance of 20 cm between the antenna and your body. The user must follow the specific operating instructions to comply with the limits of RF exposure.

IC note:

- This appliance has license-exempt transmitters/receivers, which comply with the license-exempt Radio Standards Specification (RSS) of Innovation, Science and Economic Development Canada.

Functionality of the Touch & Swipe display

Operation is subject to the following two conditions:

- This appliance may not cause interference.
- This appliance must accept any interference, including interference that may cause undesired operation of the appliance.

IC Radio Frequency Exposure Statement:

- This appliance is found to comply with IC RSS-102 radio frequency (RF) exposure limits set for an uncontrolled environment. This appliance should be installed and operated at a minimum separation distance of 20 cm between the antenna and your body.

Specialist personnel qualifications:

The appliance may only be installed, tested, maintained, and commissioned by specialist personnel who are familiar with the installation, commissioning, and operation of the appliance.

Specialist personnel are persons who, on account of their specialist training, knowledge and experience as well as their knowledge of the relevant standards, are able to assess and perform the work assigned to them and identify potential hazards. They must have training, instruction, and authorization to work on the appliance.

Symbols on the device:



The symbol may be located on the compressor. It refers to the oil in the compressor and refers to the following danger: **Can be fatal if swallowed or inhaled.** This notice only applies for recycling. There is no danger during normal operation.



WARNING: Risk of fire / flammable materials. The symbol is located on the compressor and indicates the danger from flammable materials. Do not remove the label.



The symbol is located on the back of the appliance near the alarm relay and indicates the following danger: **Electric shock!** Even if an appliance is disconnected from the mains there may still be extraneous voltage. Do not remove the label.



This label or a similar one may be located on the rear of the appliance. This label indicates that there are vacuum insulation panels (VIP) or perlite panels in the door and/or housing. This notice only applies for recycling. Do not remove the label.

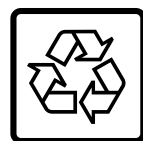

Li-ion

This label or a similar one may be located on the rear of the appliance. It refers to the Li-ion battery installed. This notice only applies for recycling. Do not remove the label.



WARNING: Cold surface! Only touch with suitable hand protection.

This or similar sticker may be on the appliance and indicates the danger of frostbite.

Observe the warning messages and other detailed information in the other sections:

	DANGER	Indicates an immediately hazardous situation, which if not avoided, will result in death or serious injury.
	WARNING	Indicates a hazardous situation, which if not avoided, could result in death or serious injury.
	CAUTION	Indicates a hazardous situation, which if not avoided, could result in minor or moderate injury.
	NOTICE	Indicates a hazardous situation, which if not avoided, could result in damage to property.
	Note	Indicates useful advice and tips.





3 Functionality of the Touch & Swipe display

You operate your appliance using the Touch & Swipe display. You select appliance functions in the Touch & Swipe display (hereafter referred to as display) by tapping them. If you do not perform any action on the display for 10 seconds, the display either jumps back to the higher-level menu or directly to the status display.

Functionality of the Touch & Swipe display

3.1 Navigation and symbol explanation

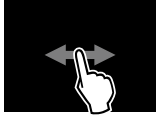
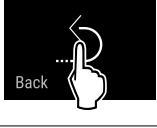
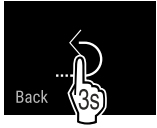
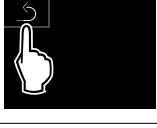
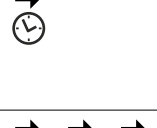
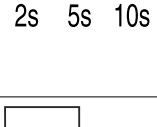
In the illustrations, different symbols are used to navigate the display. The following table describes these symbols.



Symbol	Description
	Briefly touch the display: Activates/deactivates function. Confirms selection. Opens submenu.
	Touch the display for a specified time (e.g. 3 seconds): Activates/deactivates function or value.
	Swipe left or right: Navigate in the menu.
	Briefly touch the Back symbol: Jumps back one menu level.
	Press and hold the Back symbol for 3 seconds: Jumps back to the status display.
	Briefly touch the Back symbol at the top left: Jumps back one menu level.
	Arrow with clock: It takes more than 10 seconds for the following message to appear in the display.
	Arrow with a time indication: It takes the specified amount of time until the following message appears in the display.
	“Open Settings menu” symbol: Navigates to the Settings menu and opens the settings menu. If necessary: Navigate to the desired function in the Settings menu. (see 3.2.1 Opening the Settings menu)

Symbol	Description
	“Open Advanced menu” symbol: Navigates to the Advanced menu and opens the advanced menu. If necessary: Navigate to the desired function in the Advanced menu. (see 3.2.2 Opening expanded menu)
No action for 10 seconds	If you do not perform any action on the display for 10 seconds, the display either jumps back to the higher-level menu or directly to the status display.
Open door and close it again.	If you open the door and immediately close it again, the display jumps directly back to the status display.

Note: Illustrations of the display are shown in the English version.

3.2 Menus

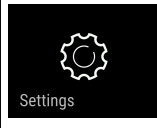
The appliance functions are distributed over various menus:

Menu	Description
Main menu	When you switch the appliance on, you are automatically in the main menu. From here you can navigate to the most important appliance functions, to the Settings menu and to the Advanced menu.
 Settings menu	The Settings menu contains additional appliance functions for setting up your appliance.
 Advanced menu	The advanced menu contains special appliance functions for setting up your appliance. Access to the Advanced menu is protected by the numerical code 1 5 1 .

3.2.1 Opening the Settings menu

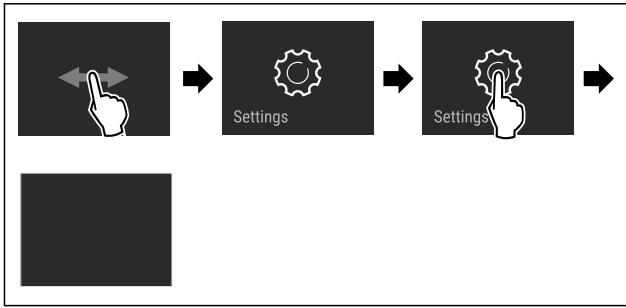

Fig. 4 Example illustration

- ▶ Carry out action steps according to the illustration.
- ▷ Settings menu is open.
- ▶ If necessary: Navigate to the desired function.

3.2.2 Opening expanded menu

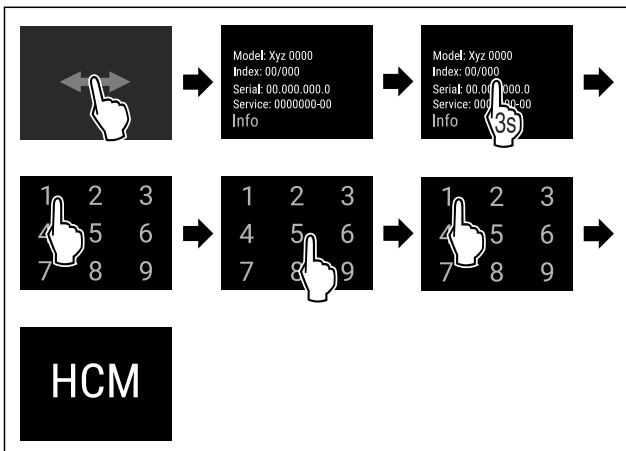

Fig. 5 Access with numerical code **151**

- ▶ Carry out action steps according to the illustration.
- ▷ Expanded menu is open.
- ▶ If necessary: Navigate to the desired function.

3.3 Sleep mode

If you do not touch the display for 1 minute, the display switches to sleep mode. In sleep mode, the display brightness is dimmed.

3.3.1 Ending sleep mode

- ▶ Touch the display briefly with your finger.
- ▷ Sleep mode is ended.

4 Start-up

4.1 Setup conditions



WARNING

Risk of fire due to moisture!
If live parts or the power cord get wet, this can cause a short circuit.

- ▶ The appliance is designed for use in enclosed spaces. Do not operate the appliance in open space or in damp areas or where there is spray.

4.1.1 Setup location



WARNING

Leaking refrigerant and oil!
Fire. The refrigerant contained within the appliance is environmentally friendly, but flammable. The oil contained within the appliance is flammable. Escaping refrigerant and oil can ignite if they are of high enough concentration and are exposed to an external heat source.

- ▶ Do not damage the pipelines of the coolant circuit and the compressor.

- Do not setup the appliance in direct sunlight, next to an oven, radiator or similar.
- The best place to set up the appliance is a dry and well ventilated room.
- If the appliance is set up in a very humid environment, condensation can form on the outside of the appliance. Always ensure sufficient airflow and ventilation in the setup location.
- The more refrigerant there is in the appliance, the larger the space it is installed in must be. If the space is too small, any leak may create a flammable mixture of gas and air. For every 8 g (0.28 oz) of refrigerant, the installation space must be at least 1 m³ (35.5 ft³). Specifications on the refrigerant in the appliance can be found on the serial tag plate inside the appliance.
- The floor of the setup location must be horizontal and even.
- The setup location must be able to withstand the weight of the appliance plus the weight when stocked to maximum capacity. (see 9.1 Technical data)
- Use in hazardous areas is not permitted.

Start-up

4.1.2 Electrical connection



WARNING

Danger of fire due to incorrect positioning!
If the power supply cable or plug touches the back of the appliance, the vibration can damage the power supply cable or the plug resulting in a short circuit.

- ▶ Make sure the power supply cable is not trapped under the appliance when you position the appliance.
- ▶ Install the appliance so that it does not touch any plugs or power cables.
- ▶ Do not connect any appliances to sockets in the area of the back of the appliance.
- ▶ Do **not** place and operate power strips/power distributors and other electronic devices (such as halogen transformers) at the back of the appliances.

4.2 Appliance dimensions

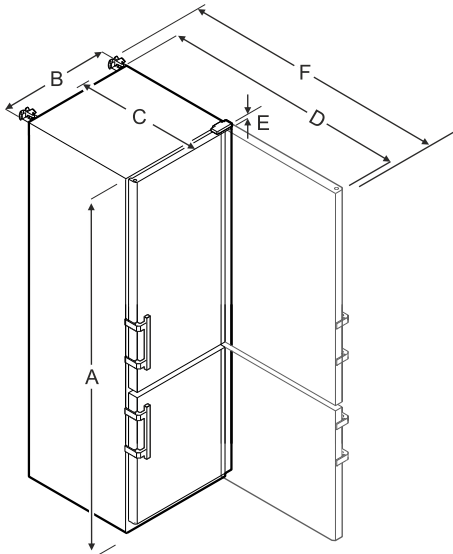

Fig. 6 Example illustration

	SCFvh 4002, SCFvh 4032
A	2044 mm (80 1/2 in)
B	597 mm (23 1/2 in)
C	654 mm (25 3/4 in)
D	1203 mm (47 3/8 in)
E	23 mm (7/8 in)
F	1241 mm (48 7/8 in)

- A = appliance height including feet / casters
- B = appliance width without handle [handle depth = 45 mm (1 6/8 in)]
- C = appliance depth without handle [handle depth = 45 mm (1 6/8 in)]

- D = appliance depth with door open
- E = hinge height
- F = appliance depth with protruding handle and anti-tipping device

4.3 Transporting the appliance



WARNING

There is a risk of injury from pieces of broken glass.*
When transporting at an altitude of more than 1500 m (4,921.26 ft), the glass panes of the door may break. This can result in sharp-edged fragments, which can cause serious injuries.

- ▶ Adopt suitable protective measures.



WARNING

Danger of injury and damage due the equipment falling over!

- ▶ Pay attention to the evenness of the ground and ramps when transporting the equipment.

Observe the following when transporting the appliance:

- ▶ Transport the appliance upright.
- ▶ Use two people when transporting the appliance.

During the first use:

- ▶ Transport the appliance packaged.

During appliance transport or at first use (e.g. when moving or cleaning):

- ▶ Empty the appliance.
- ▶ Secure the door against undesired opening.

4.4 Unpacking the appliance

- ▶ Check the appliance and the packaging for transport damage. Contact the supplier immediately if you suspect any damage. Do not connect the appliance to the power supply.
- ▶ Remove all packaging materials from the rear or the side walls of the fridge that may prevent proper installation or prevent air flow and ventilation.

4.5 Installing the door handle

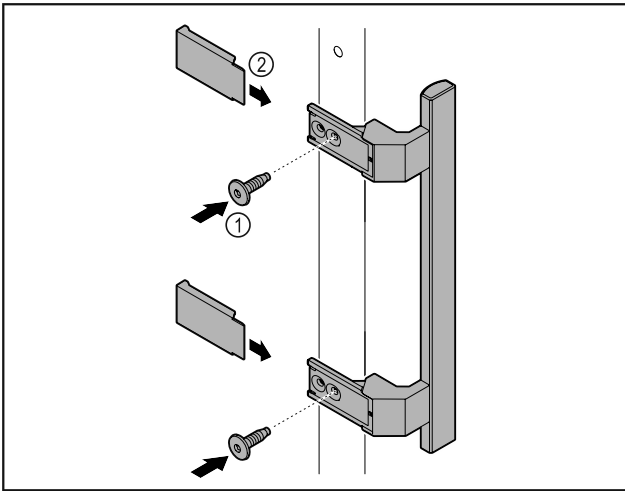

Fig. 7

- ▶ Attach handle from accessory kit to the door using supplied screws Fig. 7 (1).
- ▶ Put on cover Fig. 7 (2).
- ▶ Insert the plug from the enclosed package on the other side.*

4.6 Mounting the anti-tipping device

Tools

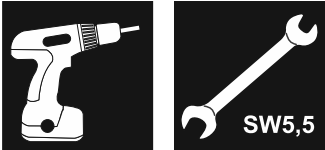

Fig. 8

WARNING

Danger of injury and damage due to appliance tipping over!

Risk of death and damage to the appliance. An appliance without a mounted anti-tip bracket may tip over while e. g. opening the door or pulling out the shelves.

- ▶ Before putting the appliance in operation: **Always** install the anti-tip bracket as described in the instructions.

Prevent appliance from tipping over.

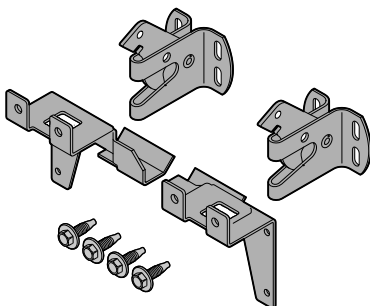

Fig. 9

The tilt protection is enclosed with the appliance. It is comprised of two retaining parts, two securing hooks and four self-tapping screws (4 x 14).

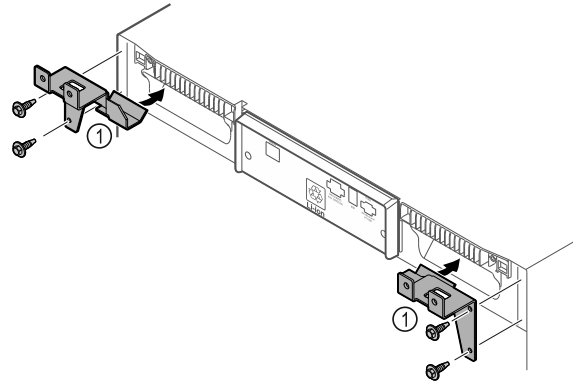

Fig. 10

- ▶ Assemble the retaining parts Fig. 10 (1) with the self-tapping screws on the appliance.
- ▶ Push appliance with retaining parts mounted against the wall.

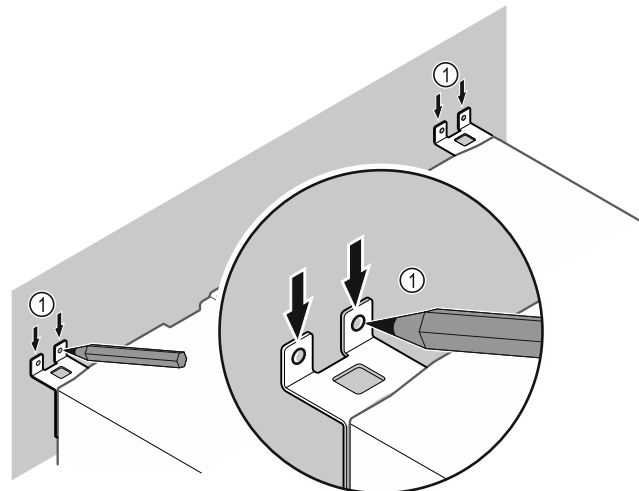
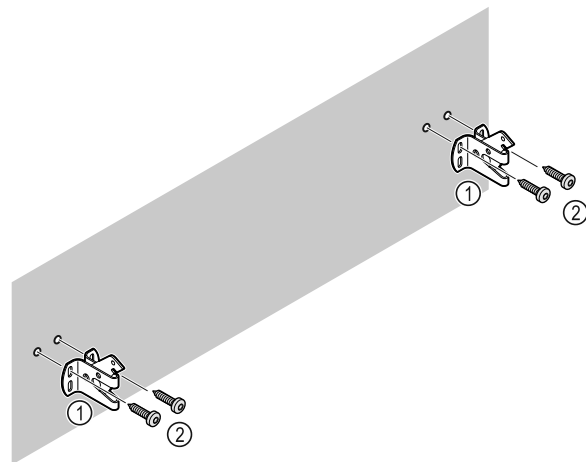

Fig. 11

- ▶ Make markings on the wall Fig. 11 (1).
- ▶ Remove appliance.



Start-up

Fig. 12

Use fixing material (e.g. wall anchors) which is appropriate for the nature of the wall (wood, concrete) and sufficient attachment points .

- ▶ Attach retaining hooks.

4.7 Setting up the appliance



CAUTION

Risk of injury and damage.

- ▶ Use 2 people to set up the appliance.



CAUTION

Risk of injury and damage.

The door can strike against the wall and become damaged as a result. In the case of glass doors, the damaged glass can cause injuries.

- ▶ Protect the door from striking against the wall. Attach a door stopper, e.g. felt stopper, to the wall.
- ▶ Connect all necessary components (e.g. power cable) to the back of the appliance and route to the side.

Note

Cables can be damaged.

- ▶ Do not crush the cable when pushing the appliance back.

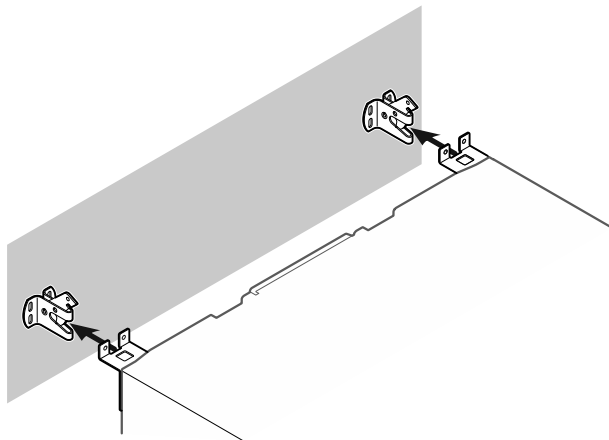

Fig. 13

- ▶ Slide the appliance up against the wall so that the retaining parts latch into the retaining hooks.
- ▷ The appliance is now secured against tipping.
- ▷ It can be released by folding back the retaining hooks.

4.8 Leveling out the appliance

NOTICE

Appliance body can become deformed and door will not close.

- ▶ Align appliance horizontally and vertically.
- ▶ Compensate for uneven floors using adjustable feet.



WARNING

Incorrect height adjustment of the adjustable foot!

Severe or fatal injuries. Incorrect height adjustment can cause the bottom part of the adjustable foot to come loose and the appliance to tip over.

- ▶ Do not unscrew the adjustable foot too far.

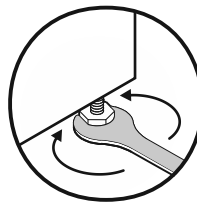

Fig. 14

Raising appliance:

- ▶ Turn adjustable foot clockwise.

Lowering appliance:

- ▶ Turn adjustable foot counterclockwise.

4.9 Setting up multiple appliances

NOTICE

Risk of damage due to condensation between the side walls.

- ▶ Do not set up the appliance directly next to another refrigeration appliance.
- ▶ Set up appliances with a space of 3 cm (1.18 in) between appliances.
- ▶ Only set up multiple appliances up to temperatures of 35 °C (95 °F) and 65 % humidity next to one another.
- ▶ At higher levels of humidity, increase the space between appliances.

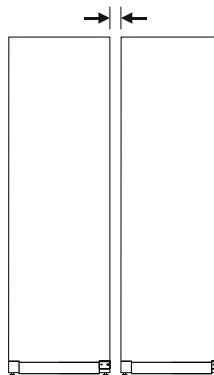

Fig. 15 Side-by-side set up

Note

A side-by-side kit is available as an accessory via Liebherr Customer Service. (see 9.3 Customer Service)

4.10 After setup

- ▶ Peel off the protective films. *
- ▶ Clean the appliance. (see 8.3 Cleaning the appliance)
- ▶ If necessary: Disinfect the appliance.
- ▶ Keep the invoice so you have the appliance and dealer information available if needed.

4.11 Disposal of packaging



WARNING

Danger of suffocation from packaging materials and films!

- ▶ Do not allow children to play with packaging materials.

The packaging is made from recyclable materials:

- Corrugated card/cardboard
- Parts made of foamed polystyrene
- Films and bags from polyethylene
- Packing bands from polypropylene
- Wood frame nailed together with a polyethylene window*
- ▶ Take the packaging material to an official collection point.

4.12 Reversing the door opening direction

Tools



WARNING

Risk of injury if the door is not reversed correctly!

- ▶ Have a specialist change the door hinge.



WARNING

Risk of injury and material damage due to heavy door!

- ▶ Only perform the conversion if you can carry a weight of 25 kg (55.11 lb).
- ▶ Always have someone help you carry out the conversion.

NOTICE

Live parts!

Damage to electrical components.

- ▶ Pull the power plug before changing the door hinges.
- ▶ Open the door.

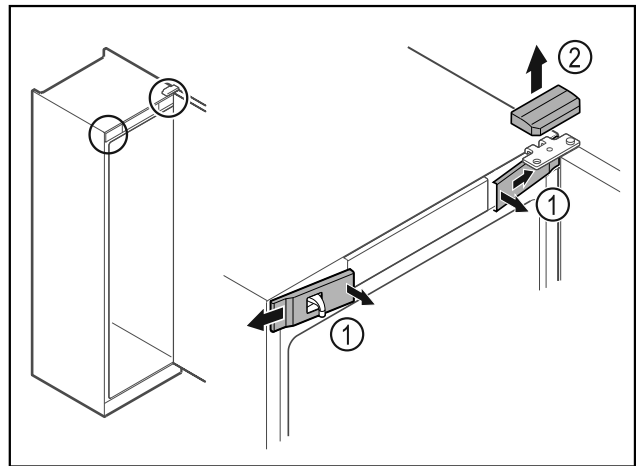

Fig. 16

- ▶ Unlatch the front covers Fig. 16 (1) on the inside and remove them sideways.
- ▶ Lift off the upper cover Fig. 16 (2).

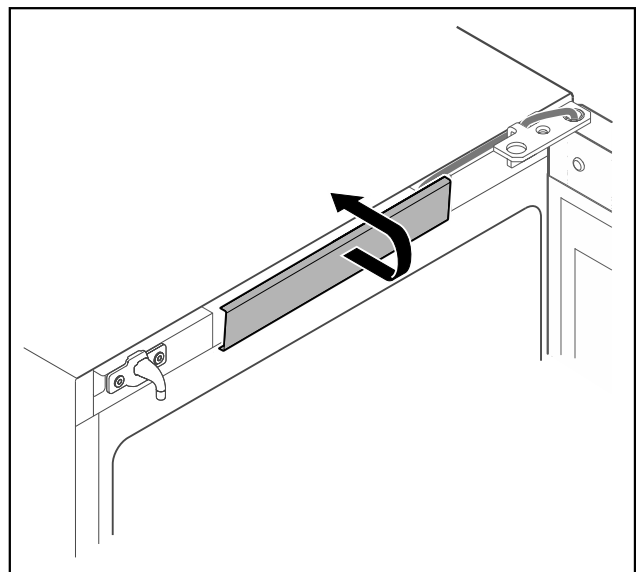

Fig. 17

- ▶ Unlatch the middle cover and remove it.

Start-up

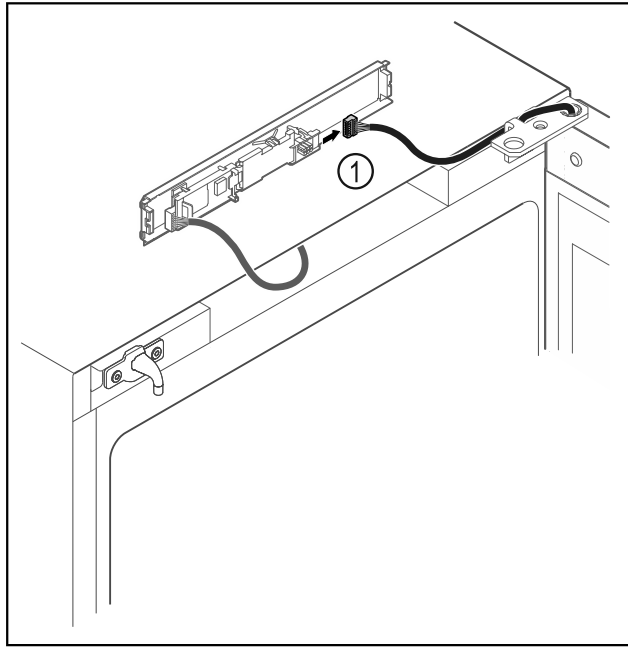

Fig. 18

- ▶ Disconnect the plug Fig. 18 (1) from the circuit board.

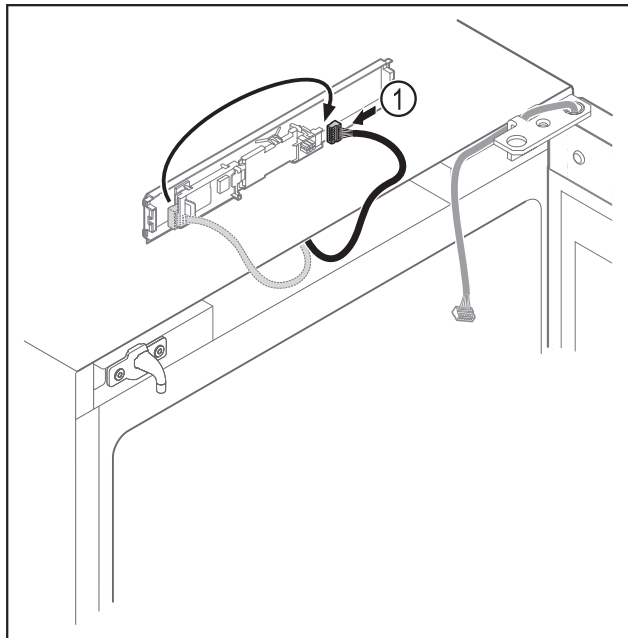

Fig. 19

- ▶ Connect the plug Fig. 19 (1) to the circuit board.

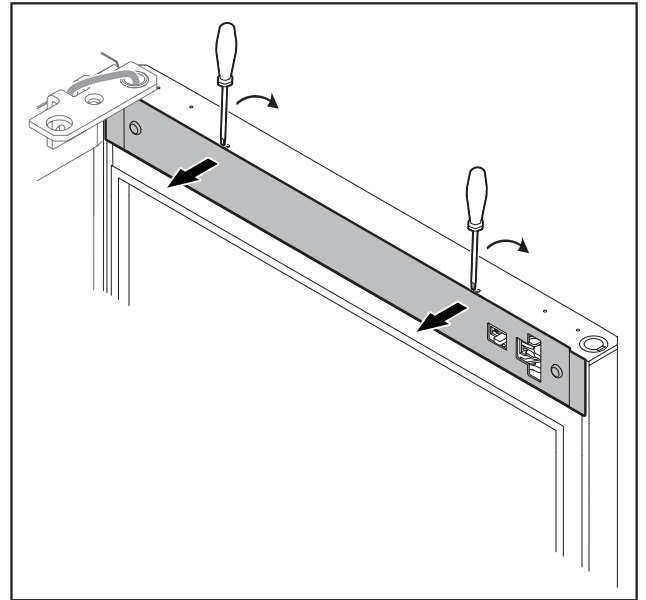

Fig. 20

- ▶ Unlatch the cover with a small screwdriver and take it off.

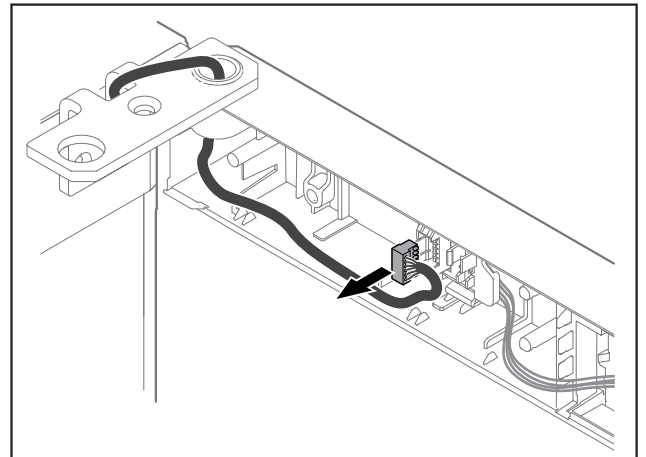

Fig. 21

- ▶ Remove the plug from the plug holder.

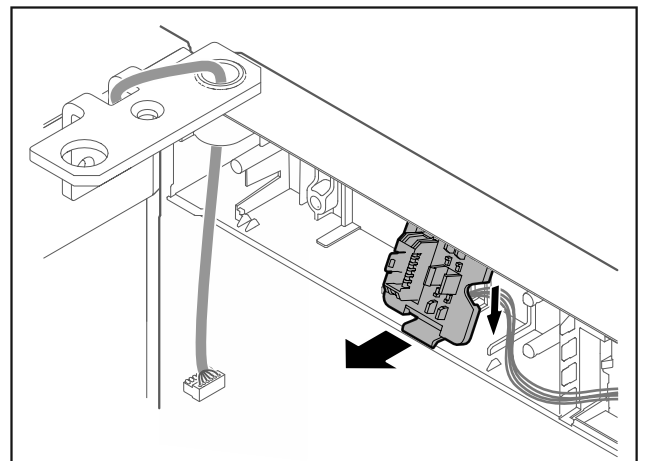

Fig. 22 The installation position of the plug holder can be rotated by 180°.

- ▶ Disengage the plug holder.

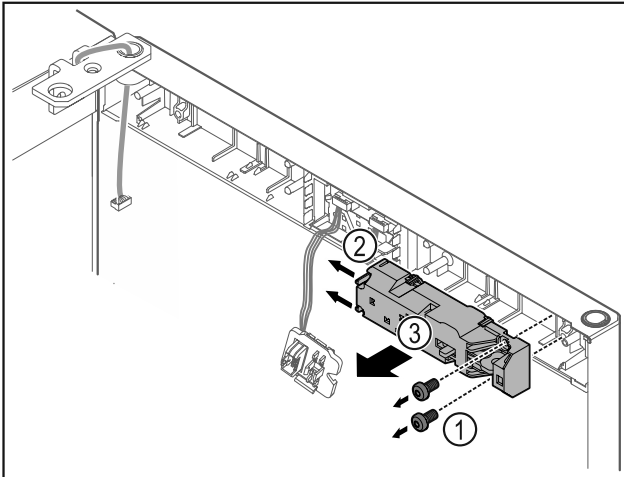

Fig. 23

- ▶ Remove the screws Fig. 23 (1).
- ▶ Press the latching lugs Fig. 23 (2) to the side and take off the remote lock Fig. 23 (3).

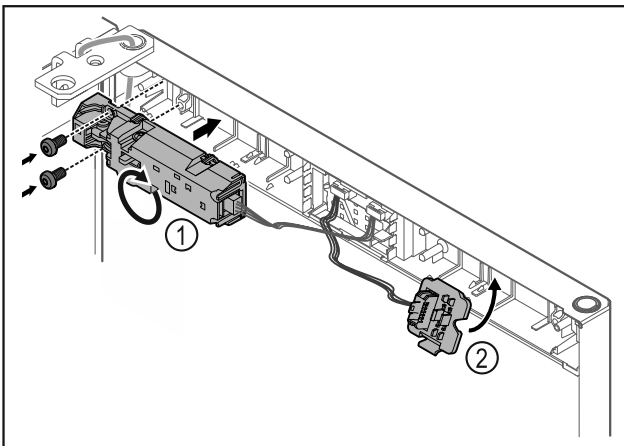

Fig. 24

- ▶ Turn the remote lock Fig. 24 (1) by 180° and fasten it on the opposite side.
- ▶ Snap in the plug holder Fig. 24 (2) on the opposite side.

NOTICE

Risk of injury if the door tips out!

- ▶ Hold the door.

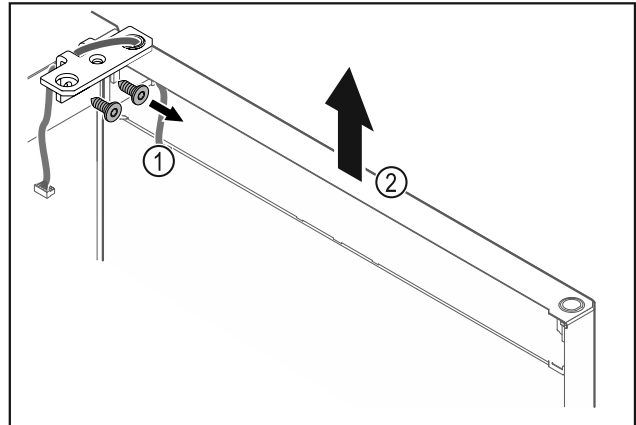

Fig. 25

- ▶ Unscrew the hinge Fig. 25 (1).
- ▶ Lift the door with the hinge straight up by Fig. 25 (2) roughly 200 mm (7.87 in) and take it off.
- ▶ Carefully place the door on a soft surface.

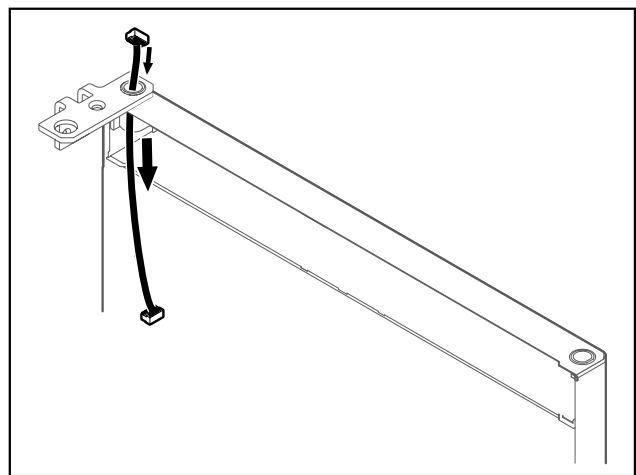

Fig. 26

- ▶ Carefully pull out the cable.

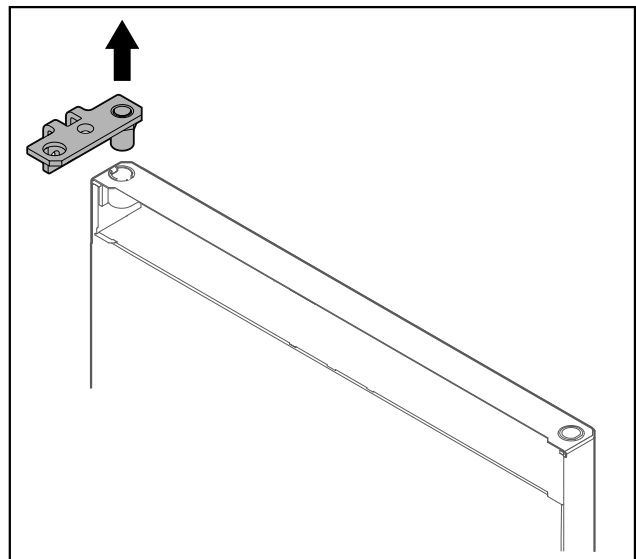

Fig. 27

Start-up

- ▶ Pull out the hinge.

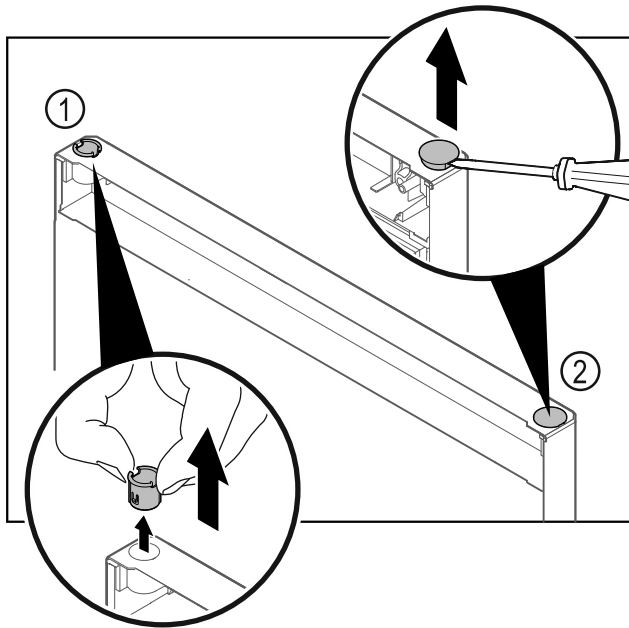

Fig. 28 Fridge compartment door

- ▶ Pull out the hinge bushing Fig. 28 (1) with your fingers.
- ▶ Carefully lift the cover plug Fig. 28 (2) with a slotted screwdriver and pull it out.

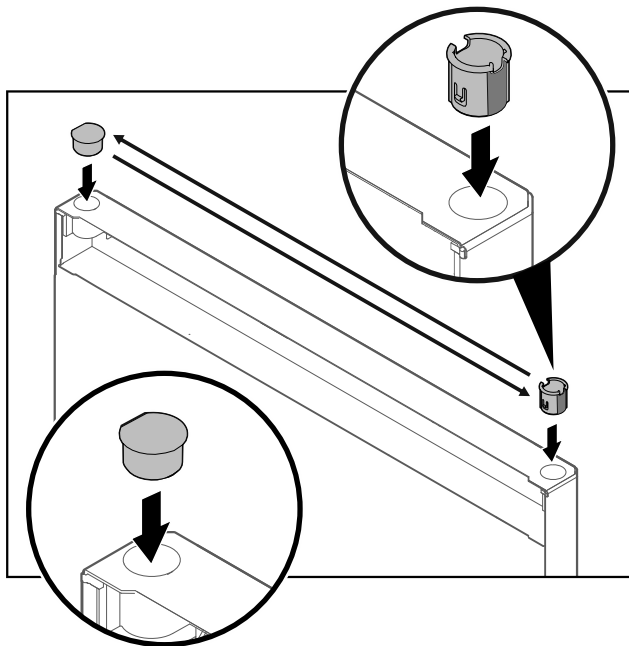

Fig. 29 Fridge compartment door

- ▶ Insert hinge bushing and cover plug on the opposite side (the flattened sides face outwards).

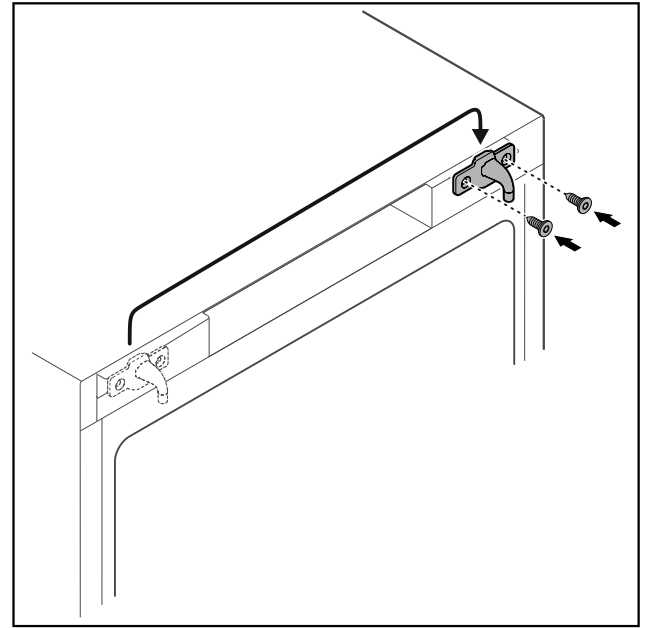

Fig. 30

- ▶ Move the door latch to the opposite side.

Note

The holes are pre-marked and must be pierced with the self-tapping screws.

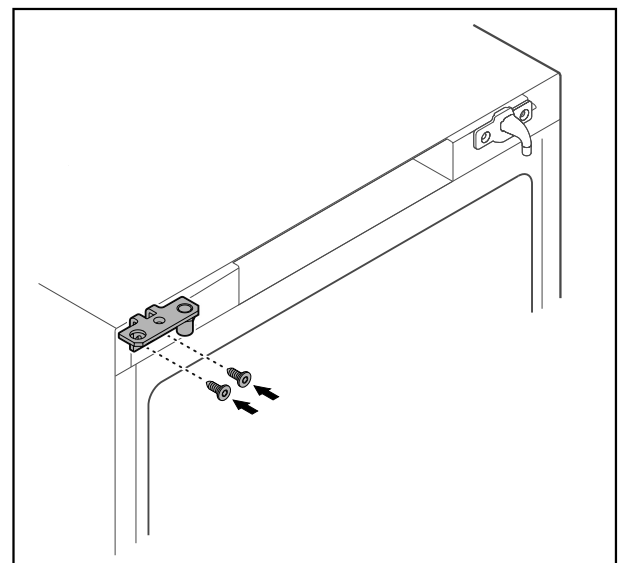

Fig. 31

- ▶ Move the hinge to the opposite side.

! WARNING

- Risk of injury and material damage if the door tips out!
- ▶ Tighten the bearing pins to the specified torque.

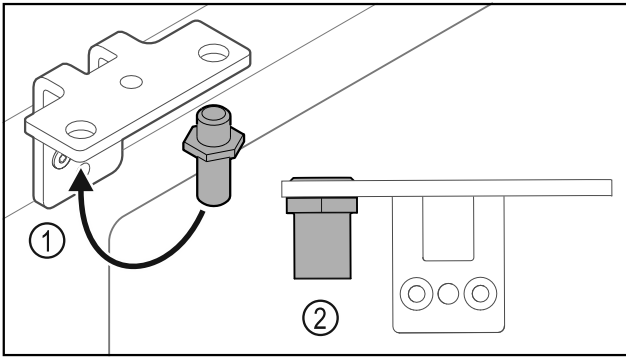

Fig. 32

- ▶ Put the pin back into the hinge Fig. 32 (1).
- ▶ Tighten the pin Fig. 32 (2) to a **torque of 12 Nm (9 ft-lb)**.
- ▶ Unscrew the hinge again.

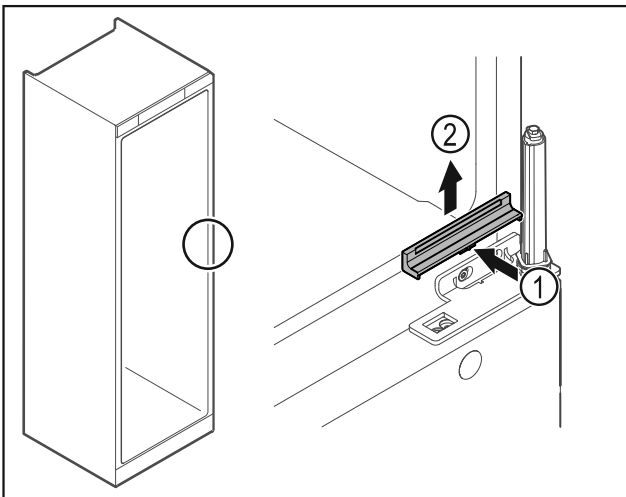

Fig. 33

- ▶ Gently press the middle of the cover Fig. 33 (1) and lift it off Fig. 33 (2).

NOTICE

Risk of injury due to tensioned spring!

- ▶ Do not disassemble the door closing system Fig. 34 (1).

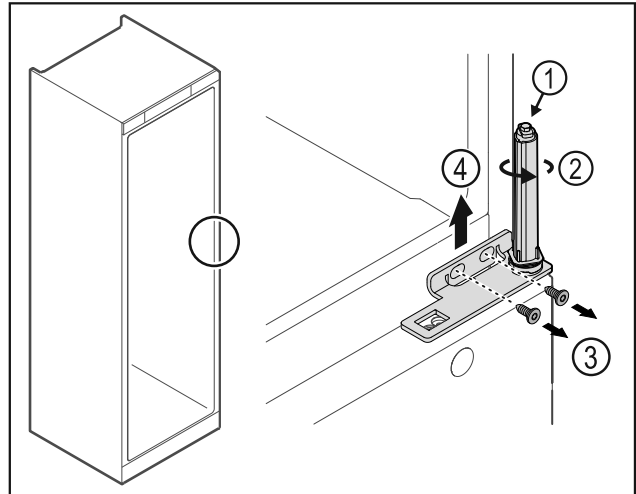

Fig. 34

- ▶ Turn the closing system Fig. 34 (2) until it clicks.
- ▷ The tension of the closing system is released.

Note

- ▶ Hold the door.
- ▶ Loosen the screws Fig. 34 (3) and lift off the hinge Fig. 34 (4).

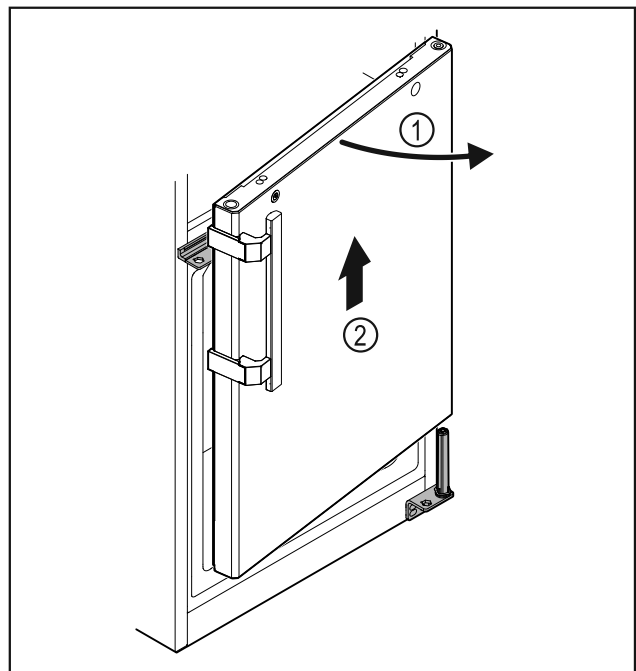

Fig. 35

- ▶ Open the door Fig. 35 (1) slightly, lift it straight up by around 200 mm (7.87 in) and take it off Fig. 35 (2).
- ▶ Carefully place the door on a soft surface.

Start-up

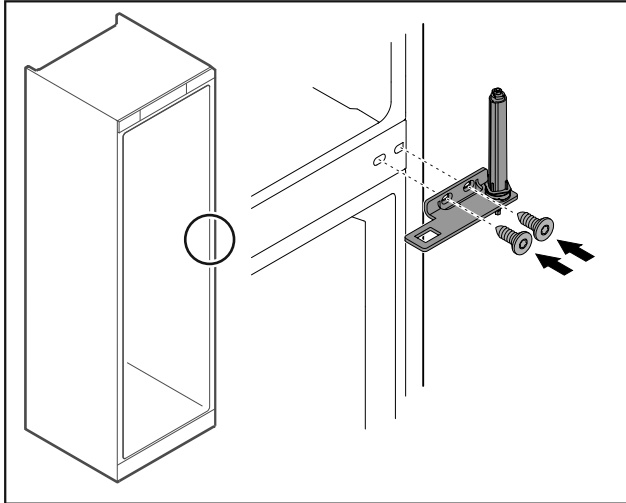

Fig. 36

- Screw the hinge back on.

Note

You must move the handle on both doors.

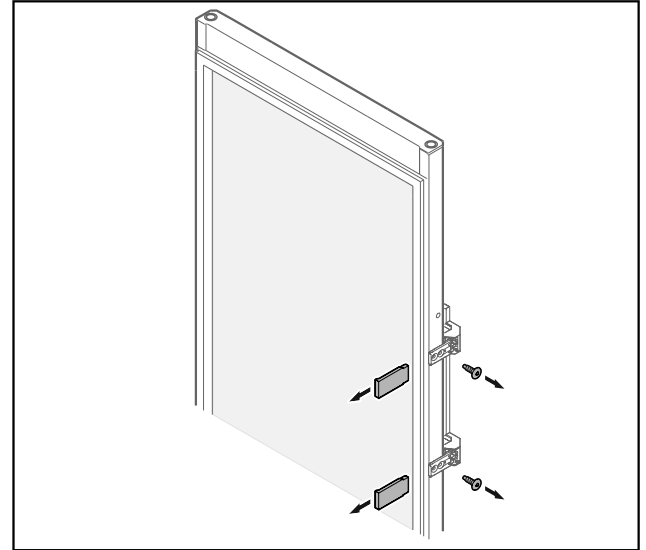

Fig. 38 Glass door*

- Remove the panels.
- Unscrew the handle.

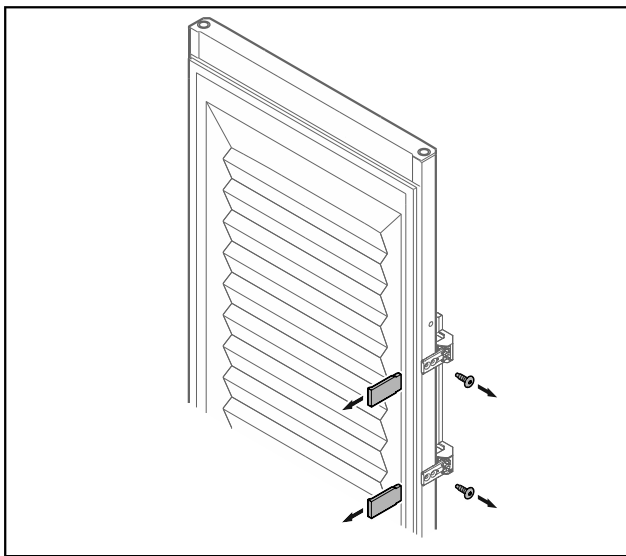

Fig. 37 Insulated door*

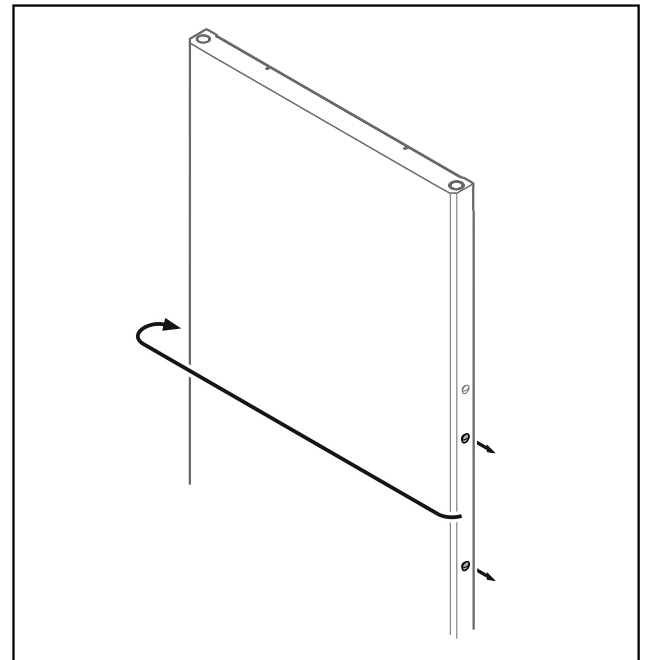

Fig. 39

- Put the stopper on the opposite side.

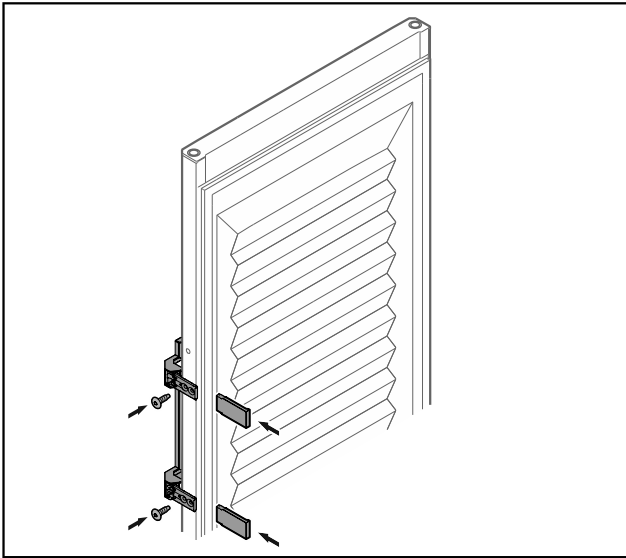

Fig. 40 Insulated door*

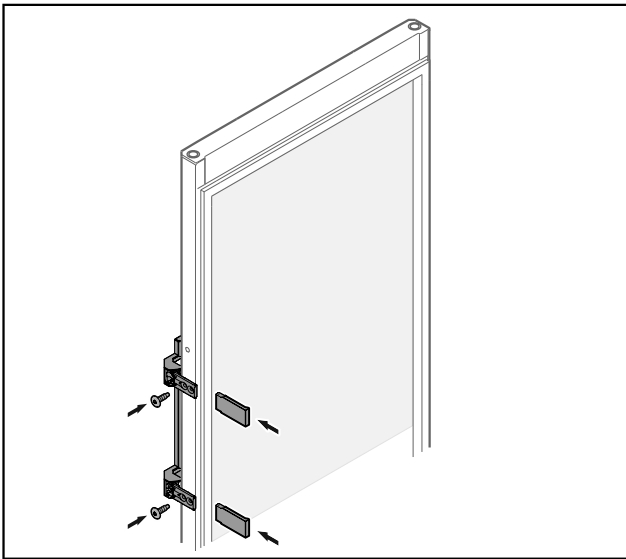

Fig. 41 Glass door*

- ▶ Screw the handle onto the opposite side.
- ▶ Attach the panels.

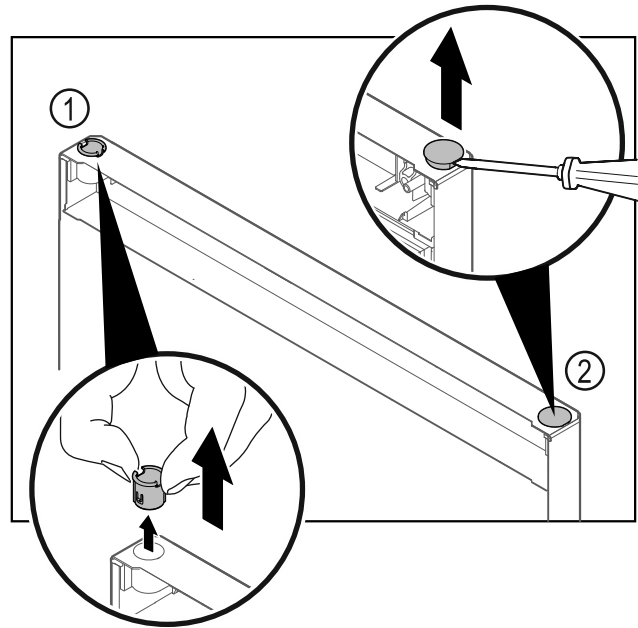

Fig. 42 Freezer compartment door

- ▶ Pull out the hinge bushing Fig. 42 (1) with your fingers.
- ▶ Carefully lift the cover plug Fig. 42 (2) with a slotted screwdriver and pull it out.

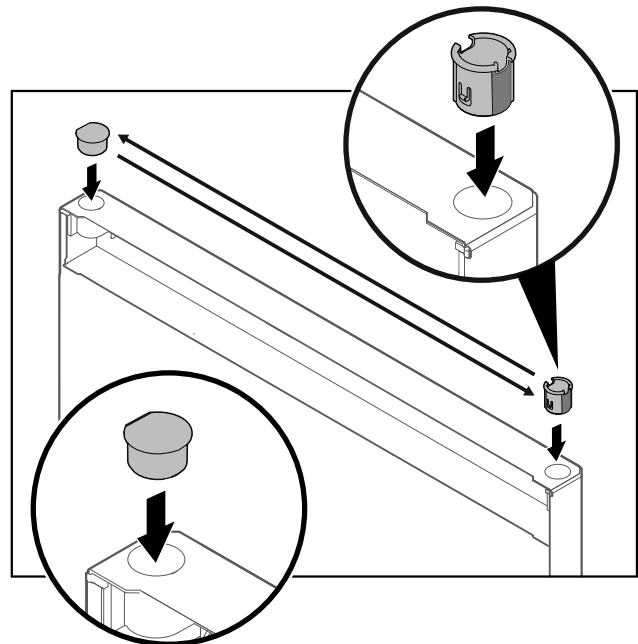

Fig. 43 Freezer compartment door

- ▶ Insert hinge bushing and cover plug on the opposite side (the flattened sides face outwards).

Start-up

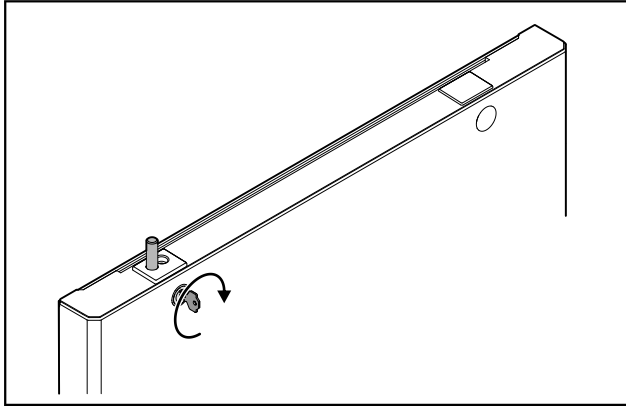

Fig. 44 Freezer compartment door

- ▶ Engage the lock.

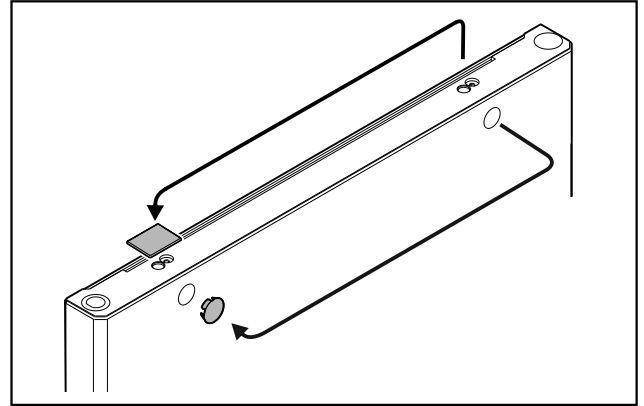

Fig. 47

- ▶ Put the covers on the opposite side.

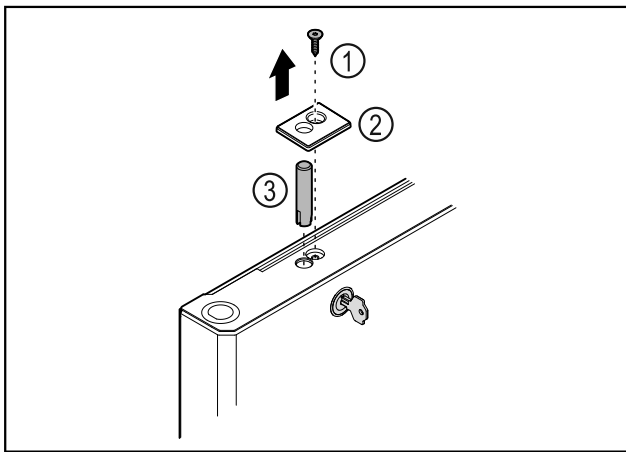

Fig. 45

- ▶ Remove the screw Fig. 45 (1).
- ▶ Unlatch the cover Fig. 45 (2) with a small screwdriver and remove it.
- ▶ Pull out the lock bolt Fig. 45 (3).

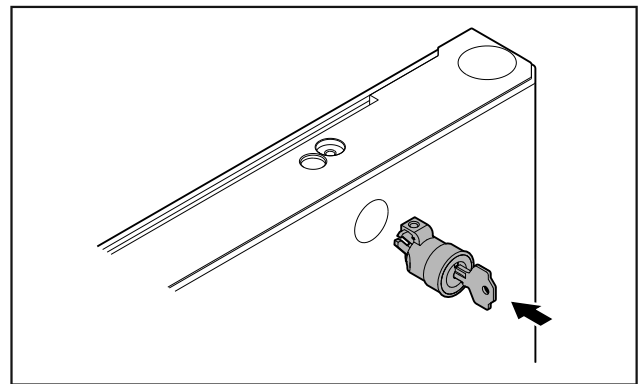

Fig. 48

- ▶ Put in the lock.

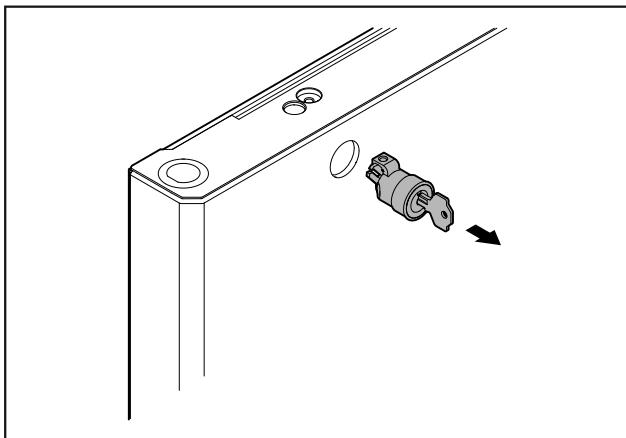

Fig. 46

- ▶ Pull out the lock.

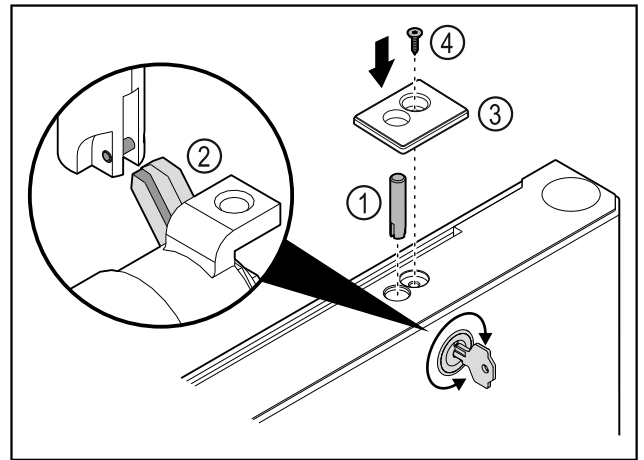

Fig. 49

- ▶ Put in the lock bolt Fig. 49 (1).
- ▶ Turn the lock slightly so that the lock bolt Fig. 49 (2) engages in the slot of the lock.
- ▶ Put in the cover Fig. 49 (3).
- ▶ Insert the screw Fig. 49 (4).

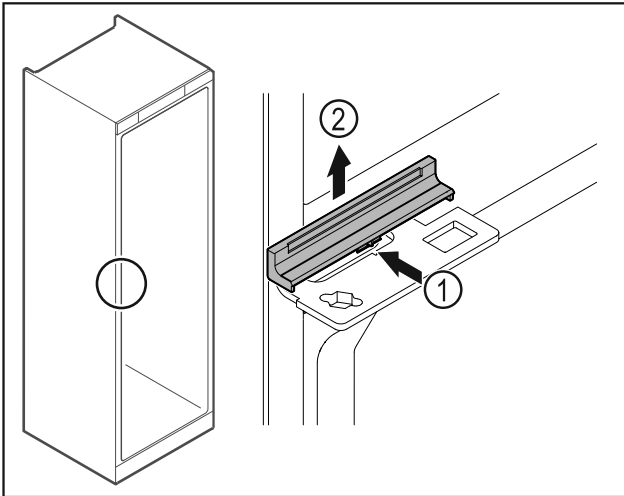

Fig. 50

- ▶ Gently press the middle of the cover Fig. 50 (1) and lift it off Fig. 50 (2).

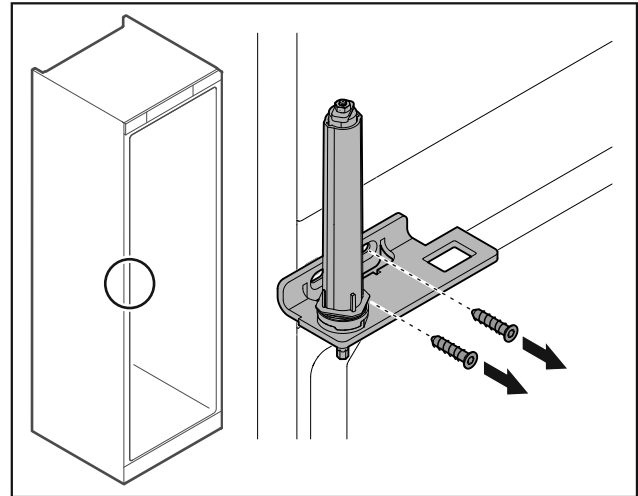

Fig. 52

- ▶ Unscrew the hinge.

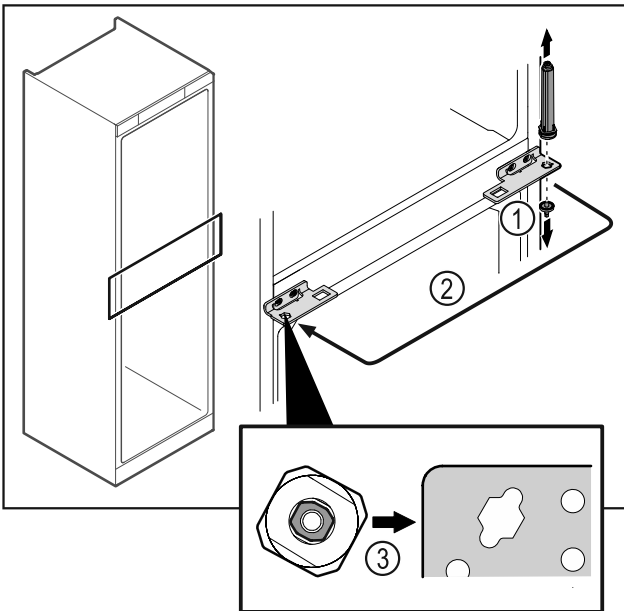

Fig. 51

- ▶ Unscrew the hinge pin Fig. 51 (1).
- ▶ Move the door closing system Fig. 51 (2).
- ▶ When inserting, make sure that the door closing system Fig. 51 (3) is aligned correctly.

NOTICE

Risk of injury due to tensioned spring!

- ▶ Do not disassemble the door closing system Fig. 53 (1).

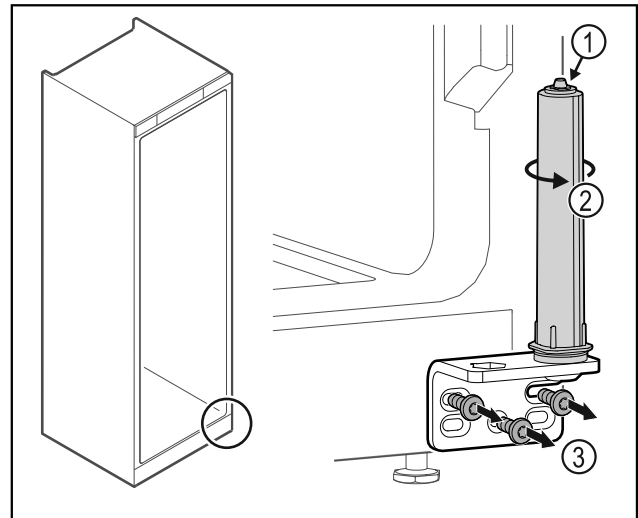

Fig. 53

- ▶ Turn the closing system Fig. 53 (2) until it clicks.
- ▷ The tension of the closing system is released.
- ▶ Unscrew the hinge Fig. 53 (3).

Note

Incorrect positioning of the height adjustment discs. It is no longer possible to secure the nut sufficiently.

- ▶ The washer must snap into place on the bottom of the locking system.

Start-up

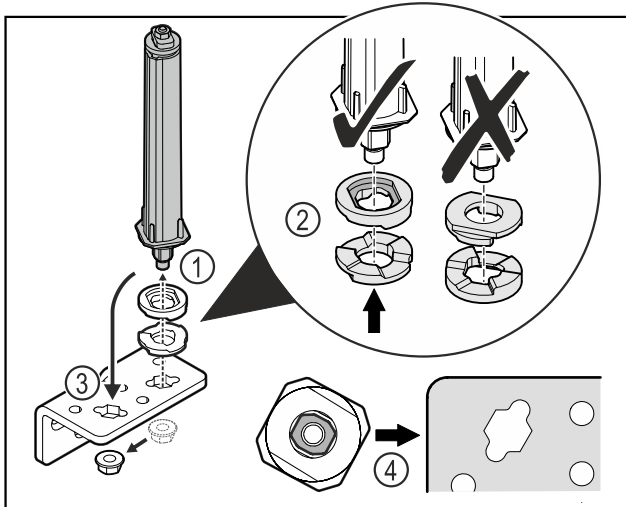

Fig. 54

- ▶ Loosen the nut and remove the door closing system Fig. 54 (1).
- ▶ Observe the correct alignment of the height adjustment washers Fig. 54 (2).
- ▶ Put the door closing system in the hinge fix in place with the nut Fig. 54 (3).
- ▶ Observe the correct alignment of the door closing system when doing so Fig. 54 (4).

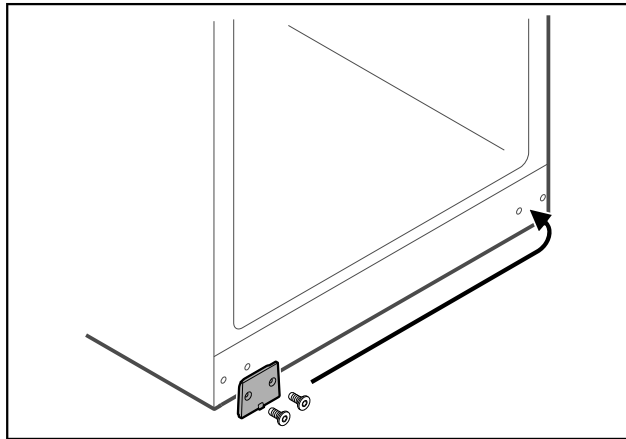

Fig. 55

- ▶ Put the cover plate on the opposite side.

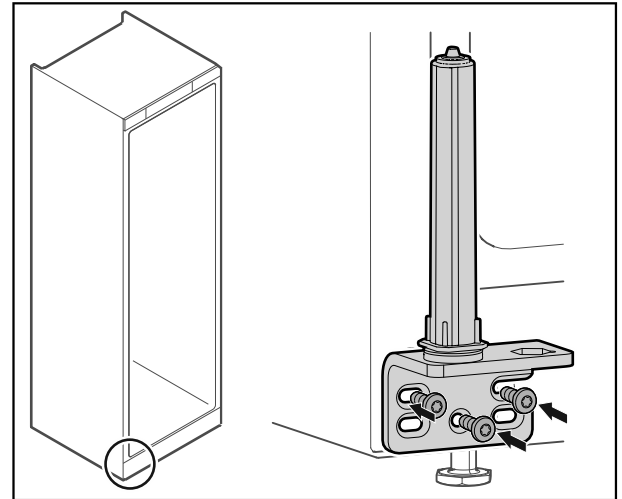

Fig. 56

- ▶ Screw the hinge onto the opposite side.

Note

Correct alignment and tension are important for the closing system to work properly.

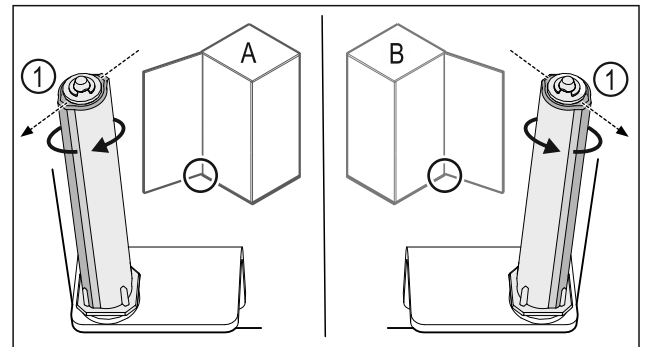

Fig. 57 Left-hinged (A) / Right-hinged (B)

- ▶ Turn the closing system against the resistance until the bar of the closing system Fig. 57 (1) points outwards.
- ▷ The closing system automatically stays in this position.
- ▷ The closing system is now aligned and pretensioned.

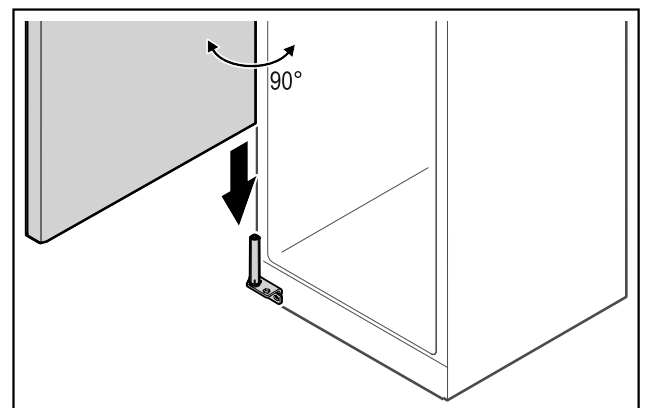

Fig. 58

- ▶ Together with a second person, lift the door from the ground and place it on the closing system.

Note

- ▶ Hold the door.

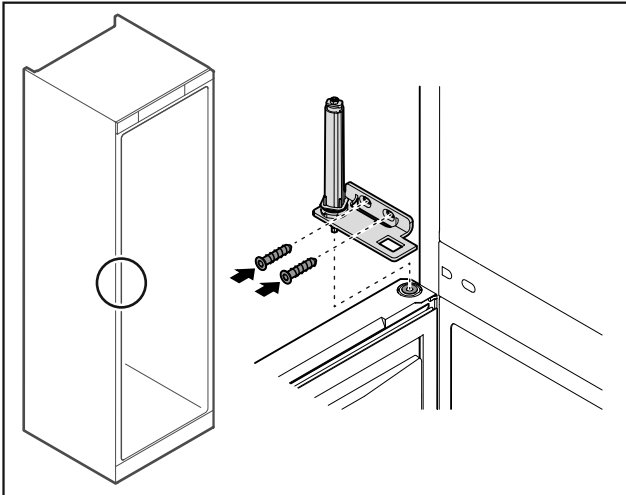

Fig. 59

- ▶ Screw on the hinge.

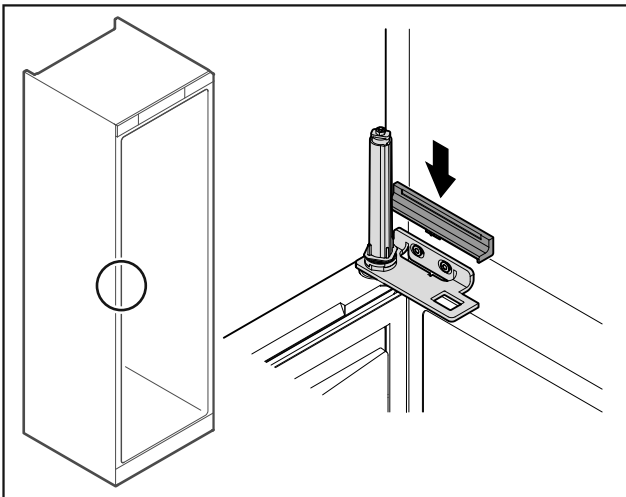

Fig. 60

- ▶ Snap on the cover.

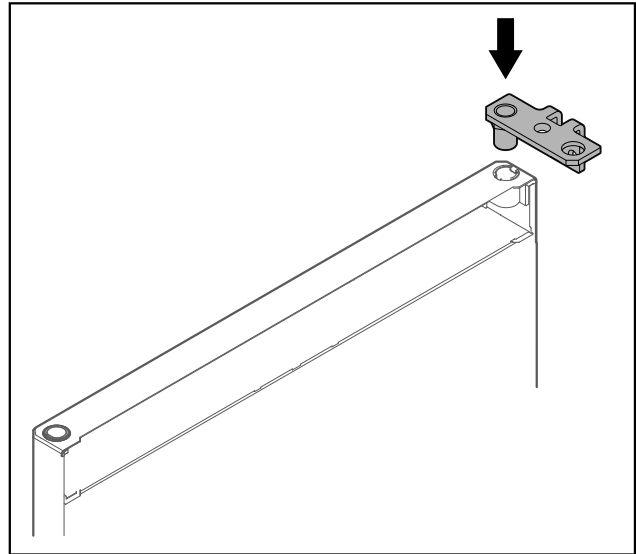

Fig. 61

- ▶ Put the hinge into the door.

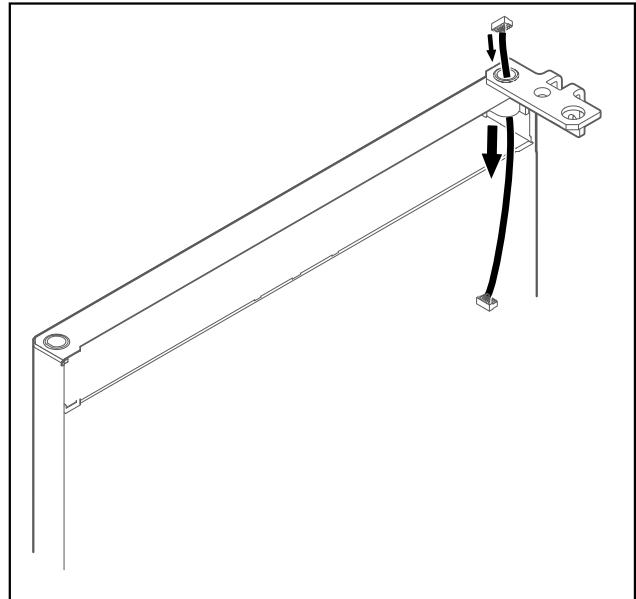

Fig. 62

- ▶ Carefully push the cable through.

NOTICE

Risk of injury if the door tips out!

- ▶ Hold the door.

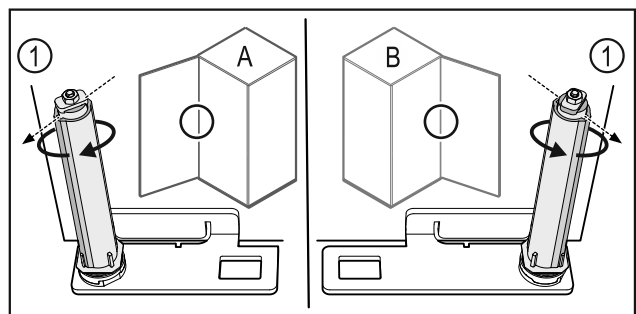

Start-up

Fig. 63 Left-hinged (A) / Right-hinged (B)

- ▶ Turn the closing system against the resistance until the bar of the closing system Fig. 63 (1) points outwards.
- ▷ The closing system automatically stays in this position.
- ▷ The closing system is now aligned and pretensioned.

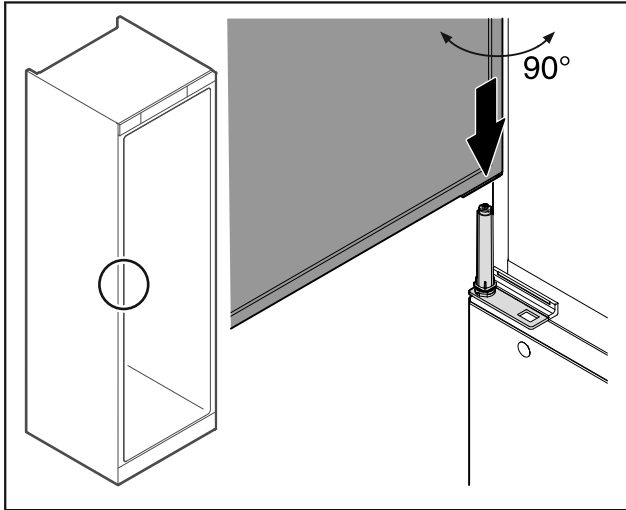

Fig. 64

- ▶ Together with a second person, lift the door from the ground.
- ▶ Carefully put the door on the closing system with the door opened at a 90° angle.

NOTICE

Material damage due to incorrect mounting!

- ▶ Do not pinch the cable when mounting the hinge.

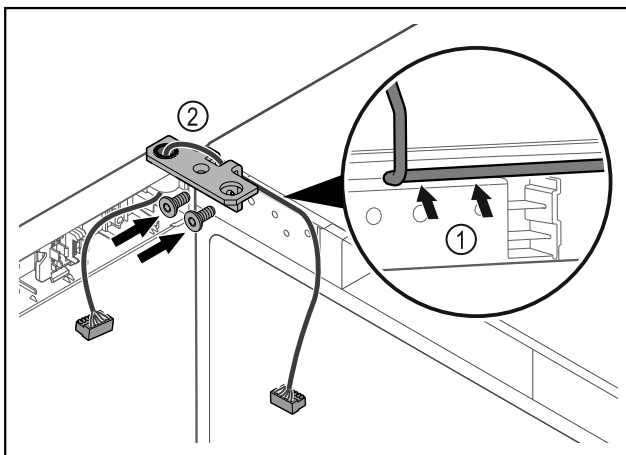

Fig. 65

- ▶ Feed the cable through the recess in the hinge and lay it carefully Fig. 65 (1).
- ▶ Screw on the hinge Fig. 65 (2).

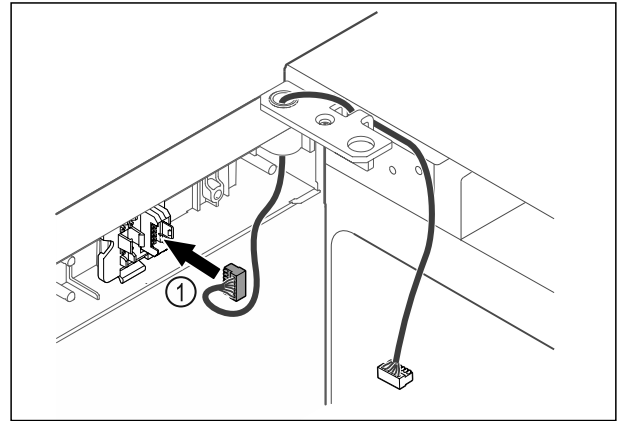

Fig. 66

- ▶ Put the plug Fig. 66 (1) in the plug holder.

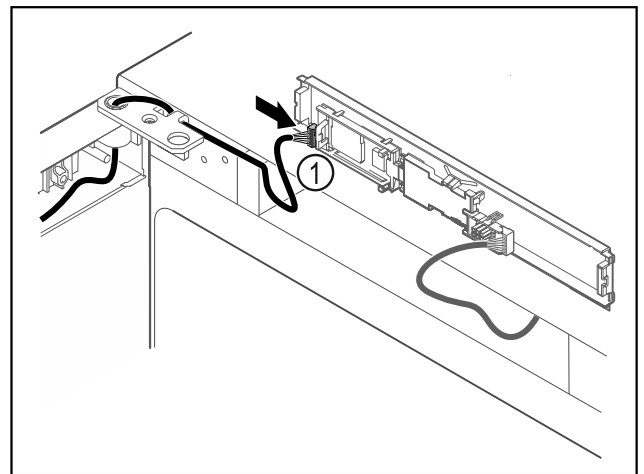

Fig. 67

- ▶ Connect the plug Fig. 67 (1) to the circuit board.

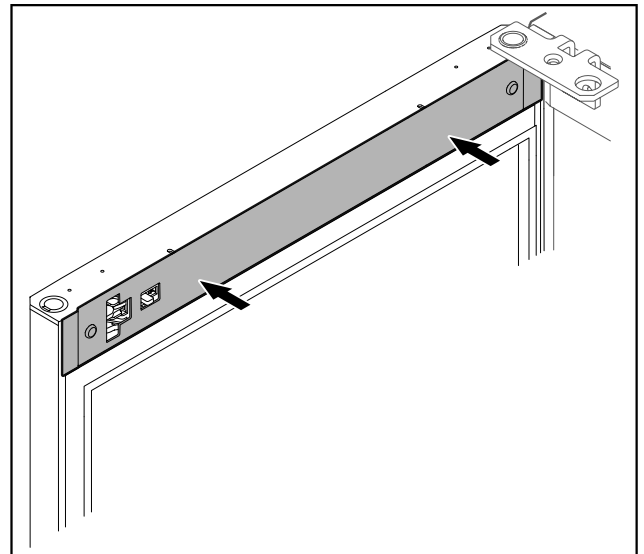

Fig. 68

- ▶ Put on the cover.

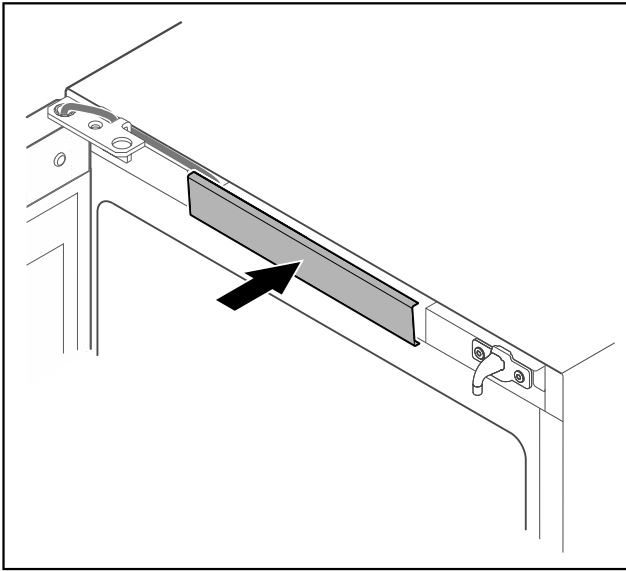

Fig. 69

- ▶ Snap in the middle cover.

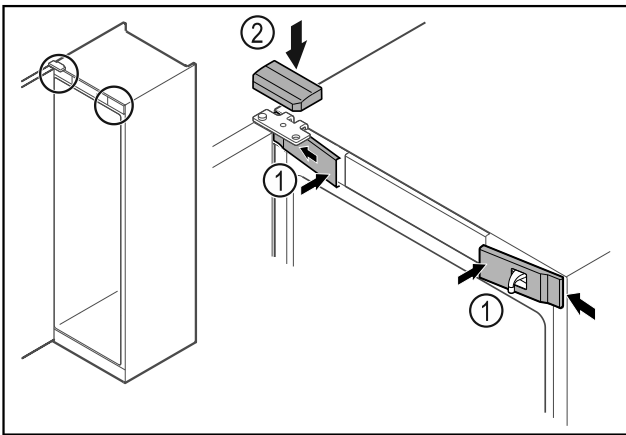

Fig. 70

- ▶ Hook in the front covers Fig. 70 (1) on the side and snap them into place.
- ▶ Snap on the top cover Fig. 70 (2) from above.
- ▶ Close the door.
- ▷ The door has now been reversed.

4.13 Aligning the door

If the door is not straight, you can adjust it on the hinge.

Align the fridge compartment door before the freezer compartment door.

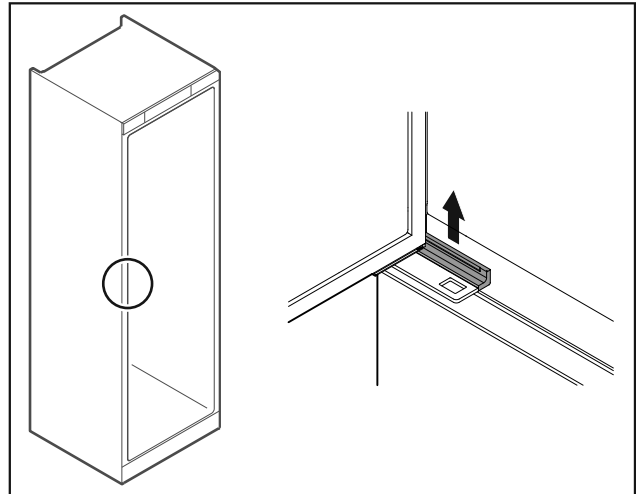

Fig. 71 Fridge compartment

- ▶ Take off the cover.

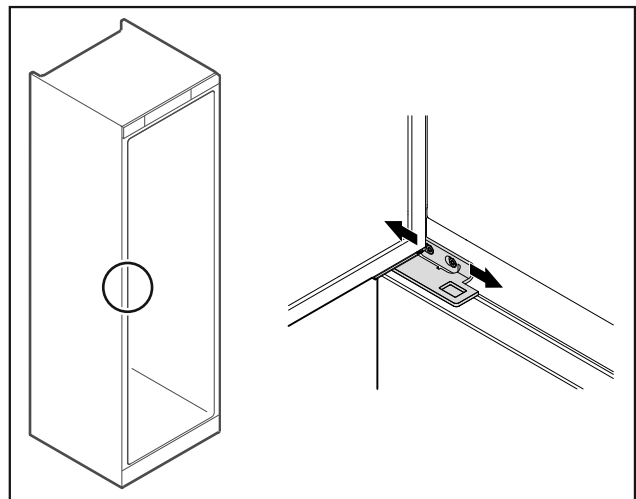

Fig. 72 Fridge compartment

- ▶ Slightly undo both screws and move the door with the hinge to the left or right.
- ▶ Tighten the screws.
- ▶ Put on the cover.

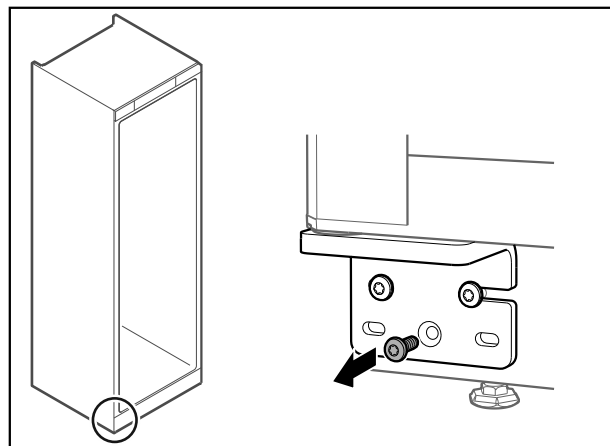

Fig. 73 Freezer compartment

- ▶ Remove the middle screw on the lower hinge.

Start-up

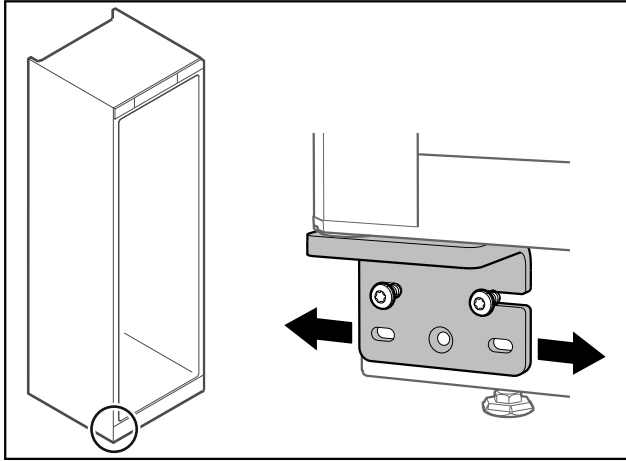

Fig. 74 Freezer compartment

- ▶ Slightly undo both screws and move the door with the hinge to the left or right.
- ▶ Fully tighten the screws (the middle screw is no longer needed).
- ▷ The doors are now aligned.

4.14 Connecting the appliance to the power supply



WARNING

Danger of electric shock and injury due to damaged appliance or damaged mains cable!

Cuts and fatal injury. If the appliance or the mains cable is damaged during transport, you may be electrocuted. You could also cut yourself on damaged parts of the appliance housing.

- ▶ Check the appliance and the mains cable for damage after transport.
- ▶ Never put the appliance into operation if the appliance or the mains cable are damaged.
- ▶ Contact Customer Service.

You can connect your appliance to the mains using the power cable supplied separately. The mains power cable has an appliance coupler at one end and a mains plug at the other end.

Make sure that the following requirements are fulfilled:

- The appliance and power cable are undamaged.
- The appliance is set up in accordance with the regulations. (see 4.5 Installing the door handle)
- Requirements for the electrical connection are met. (see 4.1 Setup conditions)
- Dimensions for connection in accordance with regulations are known and observed.
- Mains voltage and frequency correspond to the specifications on the type plate.
- The socket is grounded and fused in accordance with regulations.

- The tripping current for the fuse is between 10 A and 16 A.
- Outlet is easily accessible and is not behind the appliance.

NOTICE

Danger of damage to incorrect operation!

Damage to the electrical components of the appliance.

- ▶ Only use the supplied power cable.



WARNING

Danger of fire due to incorrect connection!

Burns.

Damage to the appliance.

- ▶ Do not use an extension cord.
- ▶ Do not use a multipoint connector strip.

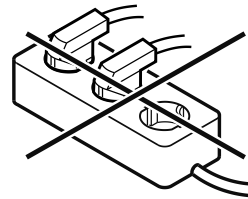

NOTICE

Danger of damage to incorrect connection!

Damage to the appliance.

- ▶ Do not connect the appliance to a stand-alone inverter, e.g. solar power systems and petrol generators.

- ▶ Connect the mains plug of the power cord to the power supply. Ensure the main plug is firmly plugged into the outlet.

- ▷ The standby symbol appears in the display.
- ▷ If no action is taken within 60 seconds: Standby symbol fades or disappears.
- ▷ Appliance is connected. For initial commissioning, see the next chapter or the operating instructions.

4.15 Switching on the appliance (first use)

Make sure that the following requirements are fulfilled:

- Appliance is set up and connected.
- All adhesive strips, adhesive and protective films and transport locks are removed from inside and outside the appliance.

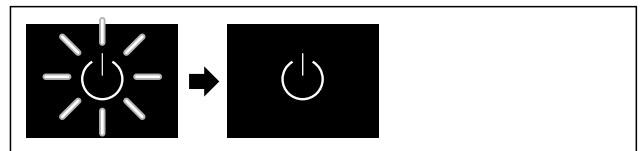

Fig. 75 Example illustration

- ▶ Standby symbol appears is flashing: Wait until the start process has completed.
- ▷ Display shows the standby symbol.

If the appliance has been supplied with factory settings, the screen language and the date/time first need to be set when using the appliance for the first time.

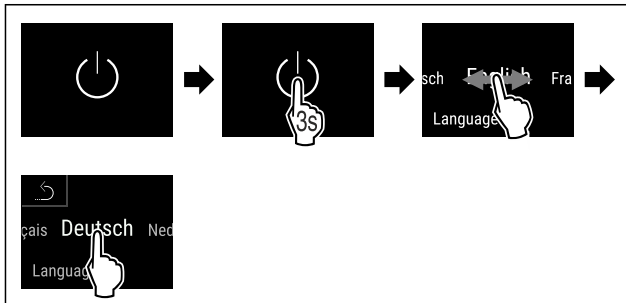

Fig. 76

- ▶ Carry out action steps according to the illustration.
- ▷ Language is set.

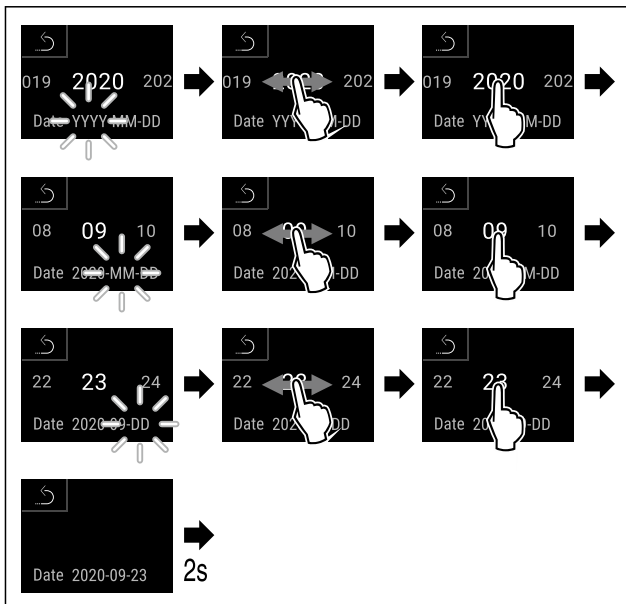

Fig. 77

- ▶ Carry out action steps according to the illustration.
- ▷ Date is set.

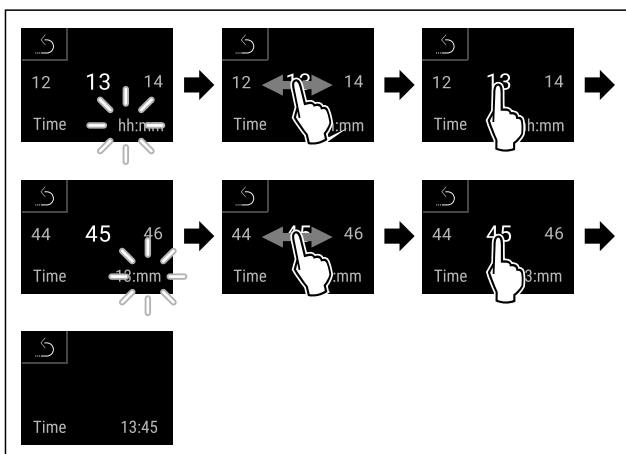

Fig. 78

- ▶ Carry out action steps according to the illustration.

- ▷ Time is set.

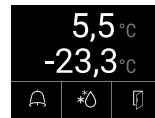

Fig. 79 Status display

- ▷ The appliance is ready for use once the temperature appears in the display.
- ▷ The temperature display flashes until the set temperature is reached.

5 Storage

5.1 Information regarding storing items

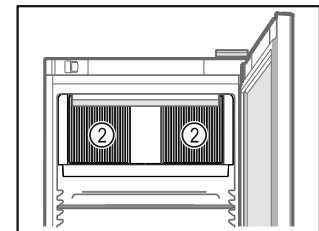
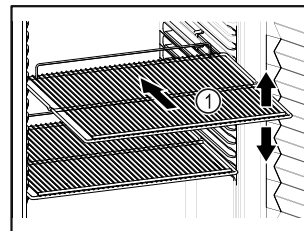

Fig. 80 Example illustration Fig. 81

When stocking items, observe the following:

- If there are adjustable shelves Fig. 80 (1), position them as required.
- Observe maximum load weight. (see 9.1 Technical data)
- Do not stock appliance until the storage temperature has been reached (maintain cold chain).
- Ventilation slots Fig. 81 (2) for recirculation fan in the interior must be kept clear.
- Refrigerated goods must not touch the rear wall.
- Refrigerated goods do not stick out beyond the shelves.
- Keep liquids in closed containers.
- Leave space when storing items for refrigeration to ensure adequate air circulation.
- Do not stack refrigerated products above the indicated height.

This is important for free air circulation and even temperature distribution in the interior.

6 Use

6.1 Control and display elements

The display provides a quick overview of the current appliance status, the temperature setting, the status of functions and settings as well as alarm and error messages.

They are operated directly on the Touch & Swipe display by swiping and tapping.

Use

Functions can be activated or deactivated and settings values can be changed.

6.1.1 Status display



Fig. 82 Status display

- (1) Actual temperatures
- (2) Alarm status
- (3) Defrosting status
- (4) Door opening status

The status display is the initial display.

It shows the temperature in the middle and three symbols in the lower area. The status display can show other different display symbols.

You can navigate from the functions and settings from the status display.

6.1.2 Display symbols

The display symbols provide information about the current status of the appliance.



Symbol	Appliance status
	Standby symbol Appliance is switched off.
	Standby (flashing) symbol Appliance is starting up.
	Temperature (flashing) Target temperature not yet reached. Appliance cooling to set temperature.
	D in the display Appliance is in demo mode.
	Maintenance display (yellow) The set time interval has expired.
	Full data memory (yellow) The data memory (999 hours) is full. From now, the oldest data will be overwritten.

Symbol	Appliance status
	Full alarm memory (yellow) The alarm memory is full. Delete individual alarms or entire memory.
	Error symbol (red) Appliance is in error state.
	Background (blue) Active setting or active function
	Bar (increasing) Press for 3 seconds to activate setting.
	Bar (decreasing) Press for 3 seconds to deactivate setting.

Status display symbols

The additional symbols on the bottom edge of the status display ensure quick access to the alarm information and details about the appliance's status.

Symbol	Appliance status
	Alarm symbol (gray) Alarm archive is empty. A brief tap opens the alarm archive.
	Alarm symbol (white) There are confirmed alarms in the alarm archive. A brief tap opens the alarm archive.
	Alarm symbol (red) There are still unconfirmed alarms in the alarm archive. A brief tap opens the alarm archive.
	Alarm symbol (red, flashing) There is an active alarm in the archive. A brief tap opens the alarm archive.
	Defrosting symbol (gray) No active defrosting process.
	Defrosting symbol (white, flashing) The defrost process is active. Briefly tapping opens the defrost appliance function. (see 6.2.21 Defrosting)

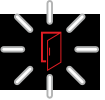
Symbol	Appliance status
	Defrosting symbol (white) The automatic defrost process is active. The function cannot be canceled.
	Door symbol (gray) The door is closed.
	Door symbol (white) The door is open.
	Door symbol (red, flashing) The door has been open for a prolonged period of time; the relevant warning message has been acknowledged. The symbol flashes until the door is closed.

Additional status display symbols

6.1.3 Acoustic signals

A signal sounds in the following cases:

- If a function or a value is confirmed.
- If a function or a value can neither be activated nor deactivated.
- As soon as a fault occurs.
- If there is an alarm message.

The alarms can be switched on and off in the customer menu.

6.2 Appliance functions

6.2.1 Notes on the appliance functions

The appliance functions are set at the factory so that your appliance is fully functional.

Before you alter, activate or deactivate the appliance functions, make sure that the following requirements are met:

- You have read and understood the descriptions of how the display works. (see 3 Functionality of the Touch & Swipe display)
- You have familiarized yourself with the operating and display elements of your appliance. (see 6.1 Control and display elements)

6.2.2 Switching appliance on and off



This function makes it possible to switch the entire appliance on and off.

Switching on appliance

Without activated demo mode:



Fig. 83

► Carry out action steps according to the illustration.

With activated demo mode:

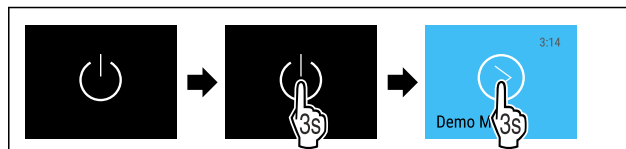

Fig. 84

► Carry out action steps according to the illustration.

Note

Deactivate demo mode before the countdown ends.

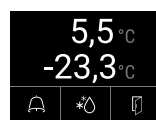

Fig. 85 Status display

▷ The temperature appears in the display.

Switching off appliance



Fig. 86

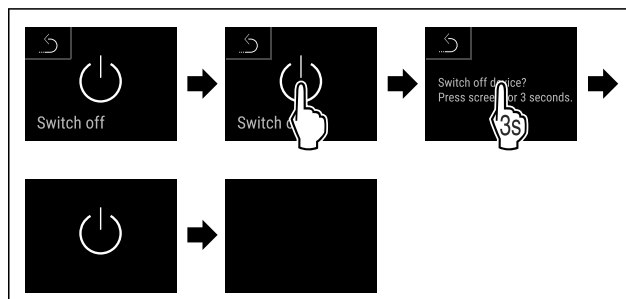

Fig. 87

► Carry out action steps according to the illustration.

▷ Standby symbol is shown in the display.

▷ Display switches off after about 10 minutes.

6.2.3 Switching temperature zone off and on



You can switch temperature zones of the appliance off independently.

Application:

- Cleaning
- Defrosting

Use

Switching the fridge compartment off

Make sure that the following requirements are fulfilled:

- ❑ Refrigerator compartment has been emptied.



Fig. 88

- ▶ Swipe left or right until corresponding function is displayed.

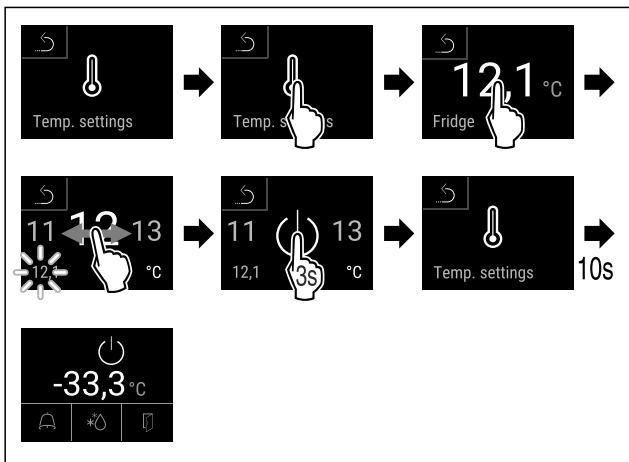

Fig. 89

- ▶ Carry out action steps according to the illustration.
- ▷ Refrigerator compartment is switched off.

Switching the freezer compartment off

Make sure that the following requirements are fulfilled:

- ❑ Freezer compartment has been emptied.



Fig. 90

- ▶ Swipe left or right until corresponding function is displayed.

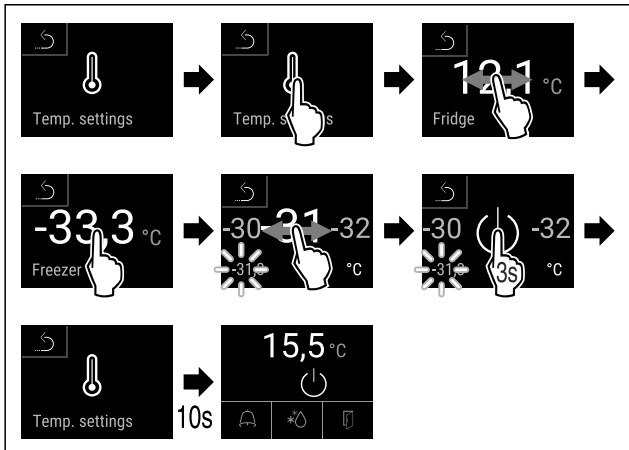

Fig. 91

- ▶ Carry out action steps according to the illustration.

- ▷ Freezer compartment is switched off.

Switching the fridge compartment on



Fig. 92

- ▶ Swipe left or right until corresponding function is displayed.

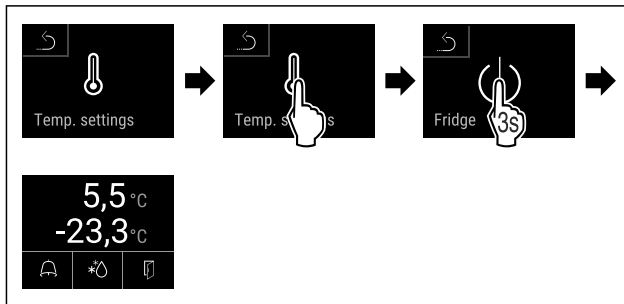

Fig. 93

- ▶ Carry out action steps according to the illustration.
- ▷ Refrigerator compartment is switched on.
- ▷ The appliance cools to the last set temperature.

Switching the freezer compartment on



Fig. 94

- ▶ Swipe left or right until corresponding function is displayed.

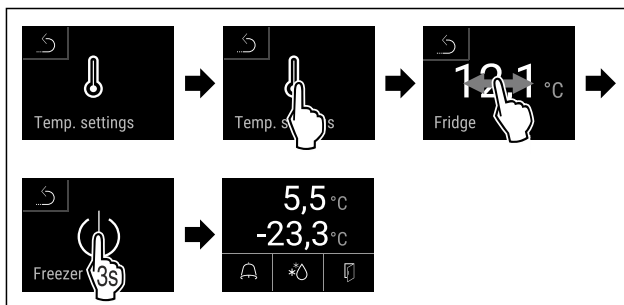

Fig. 95

- ▶ Carry out action steps according to the illustration.
- ▷ Freezer compartment is switched on.
- ▷ The appliance cools to the last set temperature.

6.2.4 Temperature



The temperature depends on the following factors:

- How often the door is opened
- How long the door is open for
- The room temperature of the installation site
- The type, temperature and amount of frozen/refrigerated items

Note

The temperature may differ from the temperature displayed in some areas of the interior.

At the correct temperature, frozen and refrigerated food will keep for longer. This avoids disposing of food unnecessarily.

Setting the temperature

The following steps describe how to increase the temperature of the fridge compartment, e.g. from 12.1 °C (54 °F) to 15.5 °C (60 °F) and how to increase the temperature of the freezer compartment, e.g. from -33.3 °C (-28 °F) to -31.8 °C (-25 °F).



Fig. 96

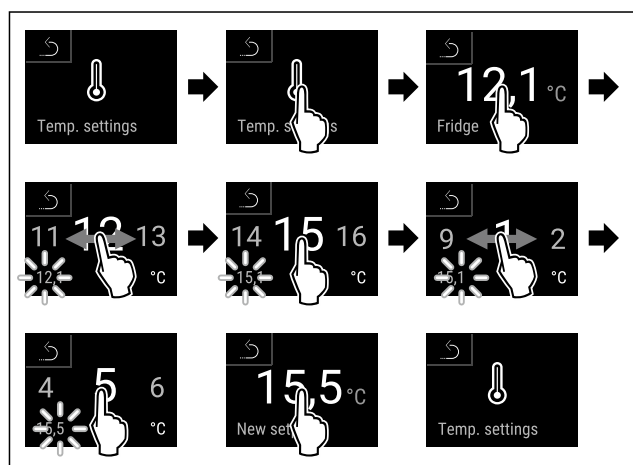

Fig. 97

► Carry out action steps according to the illustration.

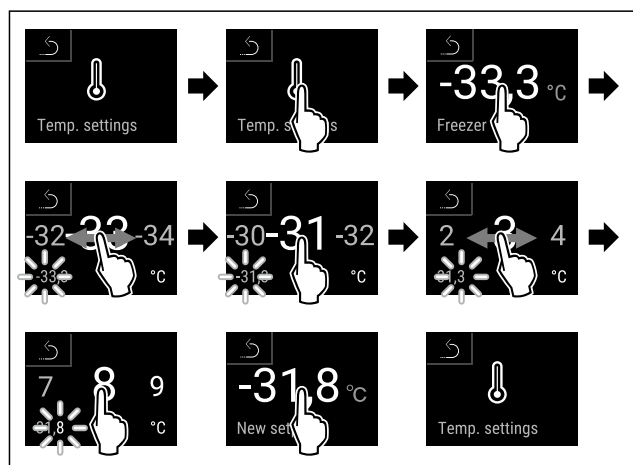

Fig. 98

► Carry out action steps according to the illustration.
▷ Temperatures are set.

6.2.5 Temperature recording



The appliance displays the minimum and maximum temperatures of the interior via this function. The recording of these temperatures starts automatically after the appliance is switched on; they are recorded at one minute intervals. A note indicating that the data memory is full is displayed after 999 hours (approx. 40 days). The temperature recording should then be reset.

Note

The entire temperature history as well as alarm and service messages are also recorded independently of this function. This data can be exported and backed up on a USB storage medium. (see 6.2.22 Data download / Datalogging)

If there is an additional product sensor installed on the appliance, there is the option of selecting this sensor to display the minimum and maximum temperatures. (see 6.2.23 Sensor calibration)

Note

The temperature recording should be reset once **after reaching the set temperature** when the appliance is commissioned. (see Resetting temperature recording) This ensures that the value for the maximum temperature is a meaningful value.

Displaying temperature recording

The temperature recording displays the length of the recording and the minimum and maximum temperatures measured during this period of time.



Fig. 99

Fridge min.	5,0 °C
Fridge max.	17,3 °C
Freezer min.	-35,2 °C
Freezer max.	-30,3 °C
Recording	65 h

Fig. 100

▷ Status screen with the temperature recordings is displayed.

Resetting temperature recording

The displayed minimum and maximum temperatures can be reset at any time. This deletes the displayed values and the recording interval starts again.



Fig. 101

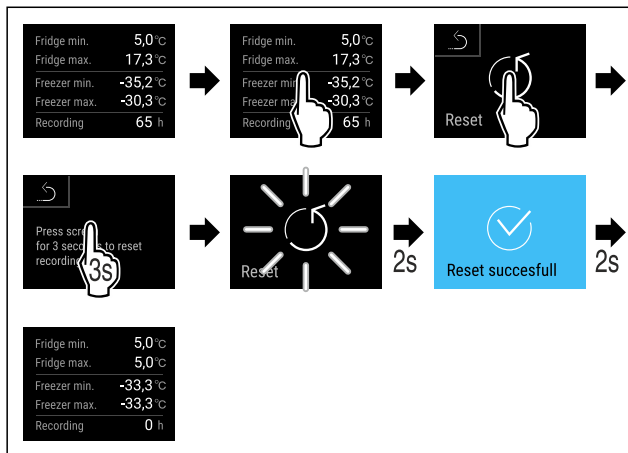

Fig. 102

- ▶ Carry out action steps according to the illustration.
- ▷ Temperature recording is reset.

6.2.6 Lighting



The appliance is equipped with interior lighting. You can keep the interior lighting on continuously. (see Switching on lighting*) *

The interior lighting comes on when you open the appliance door.

You can also deactivate this function. (see Switching off the lighting when opening the door*) *

Switching on lighting*



Fig. 103

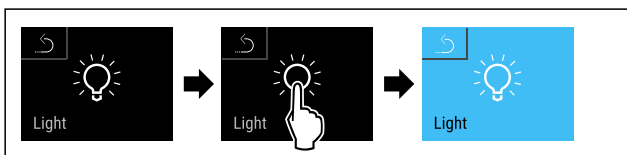

Fig. 104

- ▶ Carry out action steps according to the illustration.
- ▷ Lighting is switched on.

Switching off lighting*

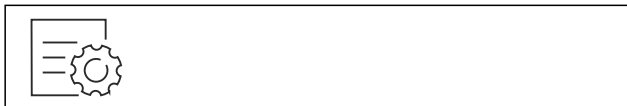

Fig. 105

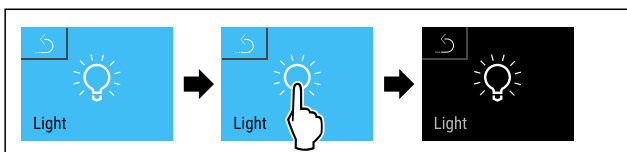

Fig. 106

- ▶ Carry out action steps according to the illustration.
- ▷ Lighting is switched off.

Switching off the lighting when opening the door*



Fig. 107

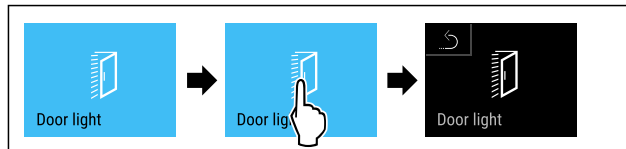

Fig. 108

- ▶ Carry out action steps according to the illustration.
- ▷ The lighting is switched off when the door is opened.

Switching on the lighting when opening the door*

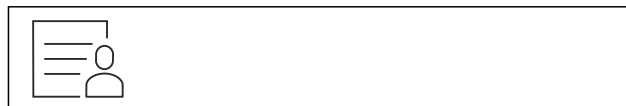

Fig. 109

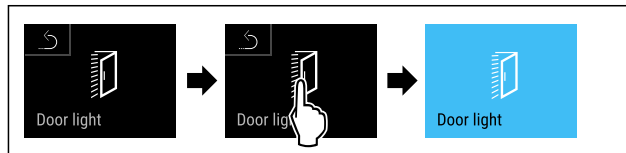

Fig. 110

- ▶ Carry out action steps according to the illustration.
- ▷ The lighting is switched on when the door is opened.

6.2.7 Settings menu access protection



This function enables the settings menu access protection via a four-digit PIN code.

Application:

- Prevent settings and functions being changed unintentionally.
- Prevent the appliance from being switched off unintentionally.
- Prevent the temperature from being adjusted unintentionally.

Note

- ▶ In the following examples, the PIN code set at the factory: **1 1 1 1** is used.

Activating the settings menu access protection



Fig. 111

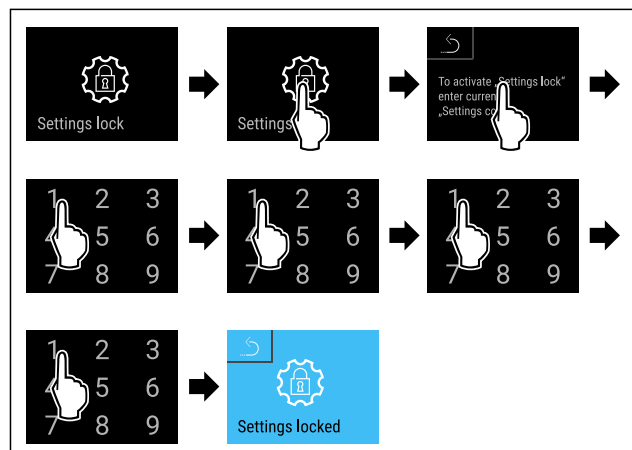

Fig. 112

- ▶ Carry out action steps according to the illustration.
- ▷ Settings menu access protection is activated.

Changing the access protection PIN code for the settings menu

(see 6.2.8 Access codes)

Deactivating the settings menu access protection

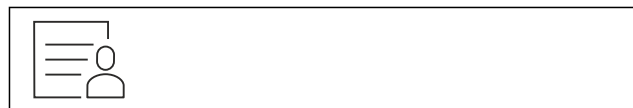

Fig. 113

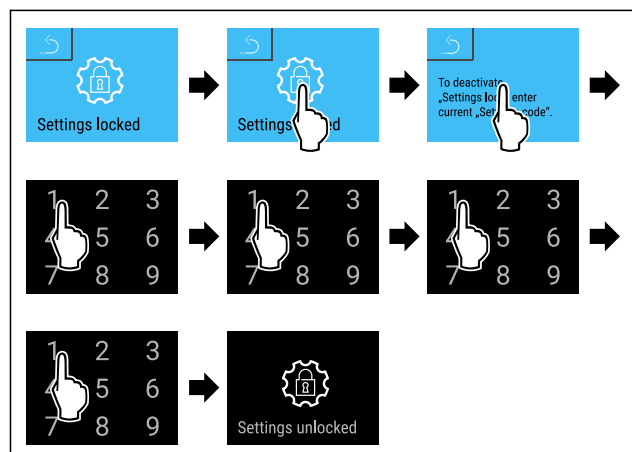

Fig. 114

- ▶ Carry out action steps according to the illustration.
- ▷ Settings menu access protection is deactivated.

Opening protected settings menu

A PIN code must be entered to open the settings menu if the access security for the settings menu is enabled. Access security is enabled automatically as soon as you exit the settings menu.

- ▶ Swipe left or right until corresponding function is displayed.

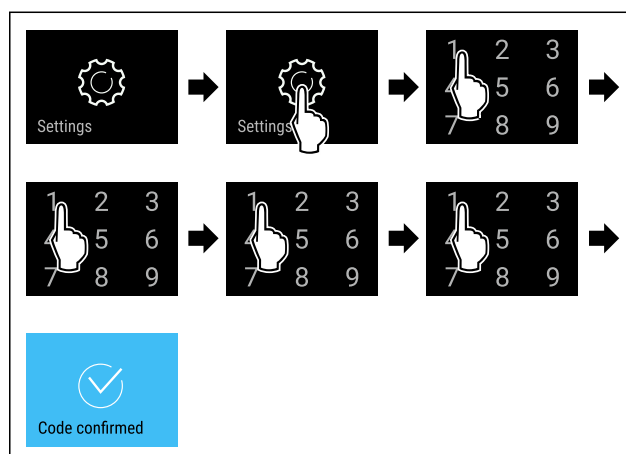

Fig. 115

- ▶ Carry out action steps according to the illustration.
- ▷ PIN code is correct: settings menu opens.

6.2.8 Access codes

Various settings are possible.

Application:

- Changing the settings code.
- Resetting the settings code.

Settings menu access protection



Changing the settings code

This setting allows the settings code for settings menu access protection to be changed.

The setting is made in 3 stages:

- Entering the old settings code
- Entering the new settings code
- Confirming the new settings code

Note

- ▶ In the following example, the default factory-set settings code **1 1 1 1** is changed.
- ▶ The new settings code is: **2 3 4 5**



Fig. 116

- ▶ **The settings menu access protection must be active.** (see 6.2.7 Settings menu access protection)
- ▶ Swipe left or right until corresponding function is displayed.

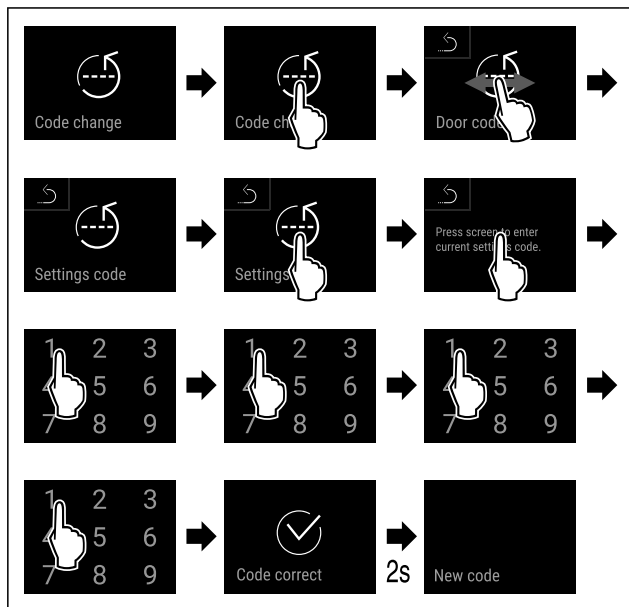

Fig. 117

- ▶ Carry out action steps according to the illustration.
- ▷ Entry of the old settings code successful.

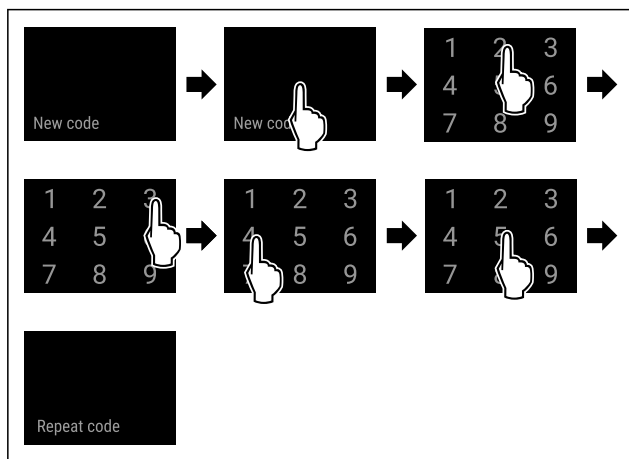

Fig. 118

- ▶ Carry out action steps according to the illustration.
- ▷ Entry of the new settings code successful.

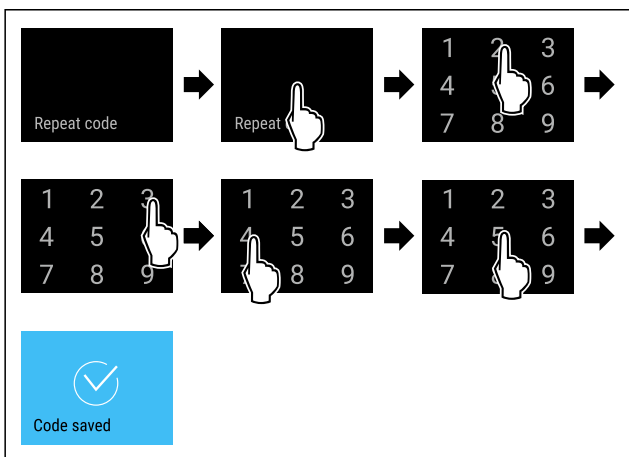

Fig. 119

- ▶ Carry out action steps according to the illustration.
- ▷ Confirmation of the new settings code successful.
- ▷ The settings code has been changed.

Resetting the settings code

The settings code for the settings menu access protection has been forgotten or is not known.

- ▶ Reset the appliance to factory settings (see 6.2.31 Resetting to factory settings).
- ▷ The appliance is reset to the original settings.
- ▷ The factory-set settings code is: **1 1 1 1**

6.2.9 Maintenance interval reminder



Setting for the time interval after which a maintenance reminder is issued.

The following values can be set:

- 7 days
- 14 days
- 30 days
- 60 days
- 90 days
- 180 days
- 360 days
- 720 days
- 1080 days
- Off

Setting maintenance interval reminder

The following steps describe how the maintenance interval is set.



Fig. 120

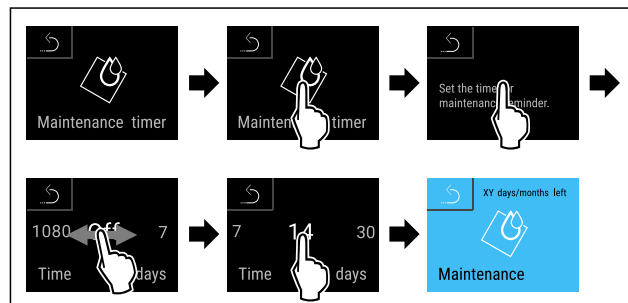

Fig. 121

- ▶ Carry out action steps according to the illustration.
- ▷ The time interval, after which the maintenance reminder is issued, is set.
- ▷ The remaining time is displayed.

6.2.10 Language



This setting allows the display language to be set.

Setting the language



Fig. 122

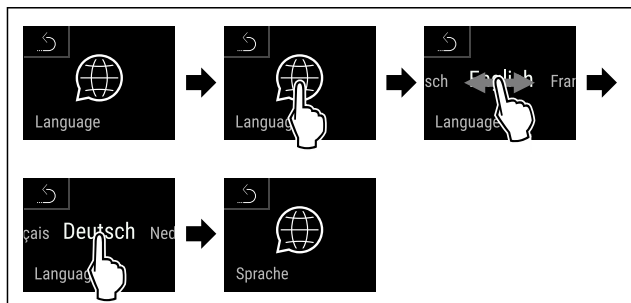

Fig. 123

- ▶ Carry out action steps according to the illustration.
- ▷ The selected language is set.

6.2.11 Date and time



This setting makes it possible to set the date and time.

Setting date and time



Fig. 124



Fig. 125

- ▶ Carry out action steps according to the illustration.

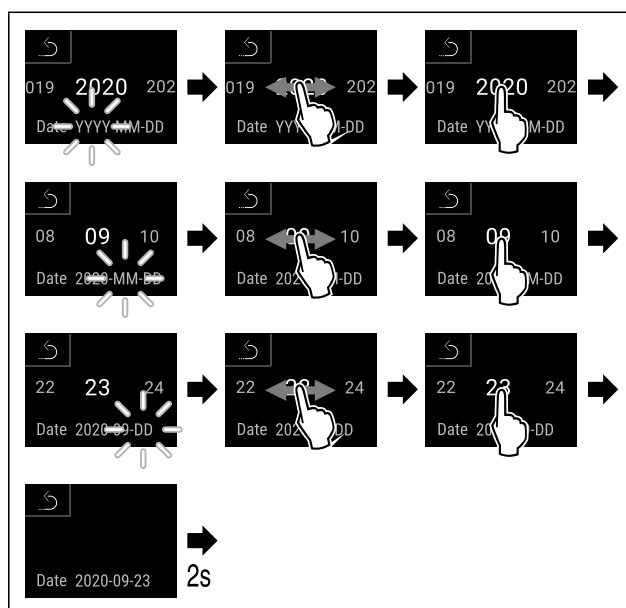

Fig. 126

- ▶ Carry out action steps according to the illustration.
- ▷ Date has been set.

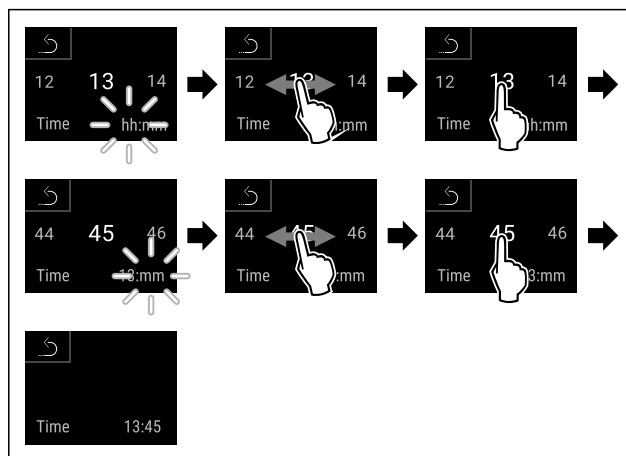

Fig. 127

- ▶ Carry out action steps according to the illustration.
- ▷ Time has been set.

6.2.12 Temperature unit



Use this function to set the temperature unit. You can set the temperature unit in either degrees Celsius or degrees Fahrenheit.

Setting the temperature unit

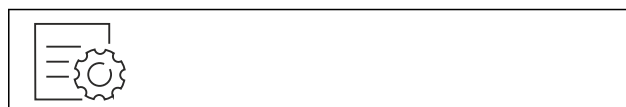

Fig. 128

Use

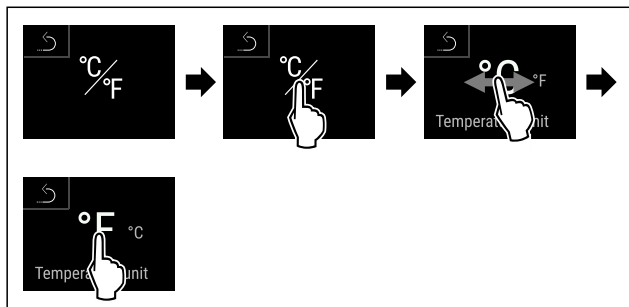

Fig. 129 Example illustration: Switching between degrees Celsius or degrees Fahrenheit.

- ▶ Carry out action steps according to the illustration.
- ▷ Temperature unit is set.

6.2.13 Display Brightness



Use this function to set the brightness of the display gradually.

You can set the following brightness levels:

- 40 %
- 60 %
- 80 %
- 100% (default setting)

Setting the brightness



Fig. 130

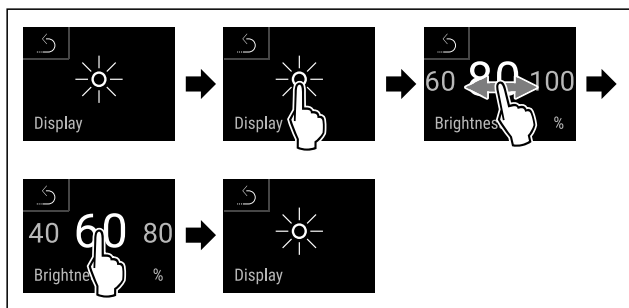

Fig. 131 Example illustration: Switching from 80% to 60%.

- ▶ Carry out action steps according to the illustration.
- ▷ Brightness is set.

6.2.14 Alarm Sound



This function enables all alarm sounds, such as the door alarm, to be switched on and off.

Activating Alarm Sound



Fig. 132



Fig. 133

- ▶ Carry out action steps according to the illustration.
- ▷ Alarm Sound is activated.

Deactivating Alarm Sound



Fig. 134

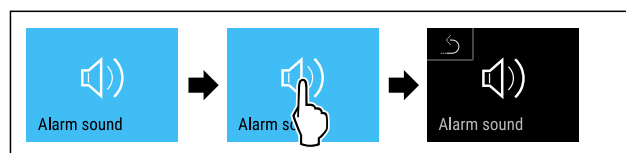

Fig. 135

- ▶ Carry out action steps according to the illustration.
- ▷ Alarm Sound is deactivated.

6.2.15 Key Sound



This function makes it possible to switch all button sounds, confirmation sounds, and the startup sound on and off.

Activating Key Sound



Fig. 136

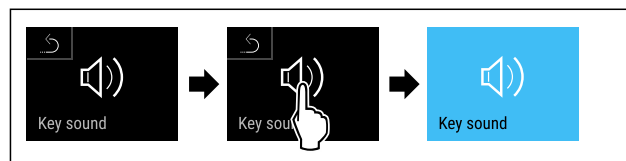

Fig. 137

- ▶ Carry out action steps according to the illustration.
- ▷ Key Sound is activated.

Deactivating Key Sound



Fig. 138

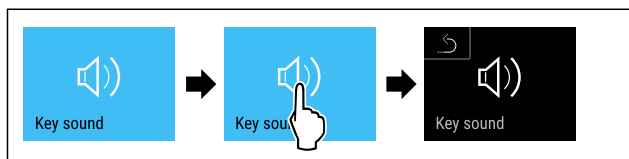

Fig. 139

- ▶ Carry out action steps according to the illustration.
- ▷ Key Sound is deactivated.

6.2.16 WiFi connection



Note

Liebherr SmartMonitoring Dashboard is not available in all countries. Check availability via the QR code by entering your model.

Note

Use of the Liebherr SmartMonitoring Dashboard at <https://smartmonitoring.liebherr.com> requires installation of a SmartModule and a commercial MyLiebherr account. When commissioning online you can register using your login data, or register again and create a company account.

This setting establishes a wireless connection between the appliance and the internet. The connection is controlled via the SmartModule. The appliance can be integrated via the browser-based [Liebherr SmartMonitoring Dashboard](#) and advanced options and customized methods relating to control, administration and monitoring can be used.

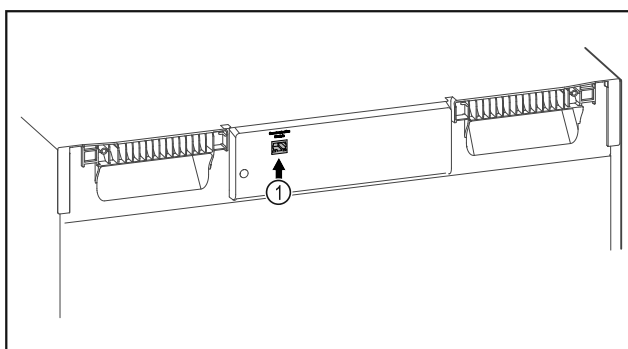

Fig. 140

Make sure that the following requirements are fulfilled:

- ❑ SmartModule Fig. 140 (1) is in use.

Establishing a connection

You commission and set up your SmartModule online via the [Liebherr SmartMonitoring Dashboard](#) on your web-enabled device.

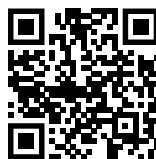

Fig. 141

- ▶ Open [Liebherr SmartMonitoring Dashboard](#). (see Fig. 141)

On the fridge or freezer:



Fig. 142

Note

The settings menu access protection is activated. (see 6.2.7 Settings menu access protection)

- ▶ Enter the chosen PIN code. The settings menu opens.

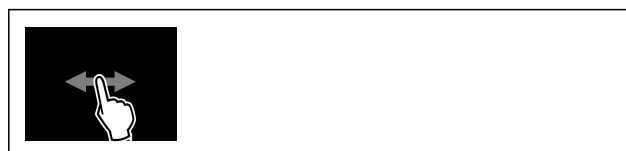

Fig. 143

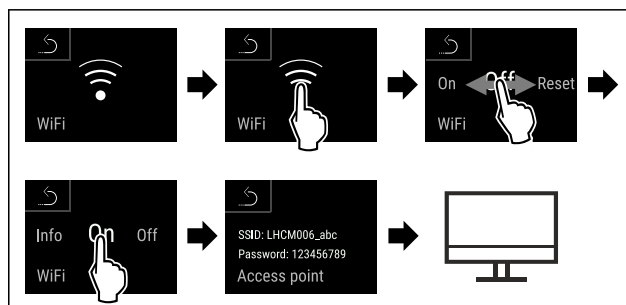

Fig. 144

- ▶ Carry out action steps according to the illustration.
- ▶ Continue the set-up procedure on your web-enabled device: [Liebherr SmartMonitoring Dashboard](#)

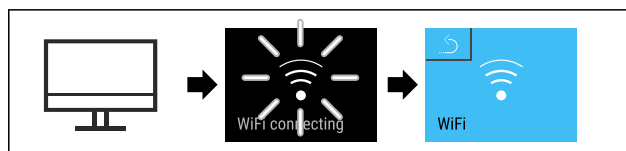

Fig. 145

- ▶ Carry out action steps according to the illustration.
- ▷ Connection is established: WiFi connecting appears. The symbol flashes.
- ▶ Follow the [Liebherr SmartMonitoring Dashboard](#) instructions.
- ▷ Connection is established.

Use

Disconnecting



Fig. 146

Note

The settings menu access protection is activated. (see 6.2.7 Settings menu access protection)

- ▶ Enter the chosen PIN code. The settings menu opens.

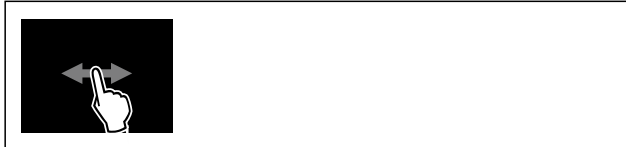

Fig. 147

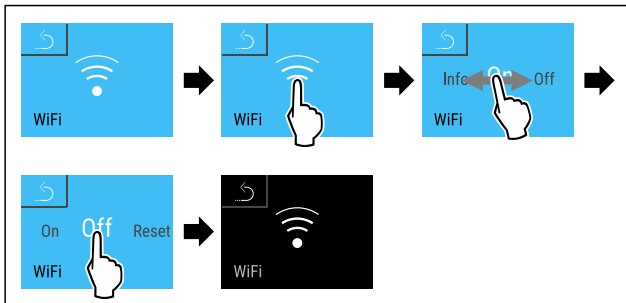

Fig. 148

- ▶ Carry out action steps according to the illustration.
- ▷ There is no connection.

Resetting connection

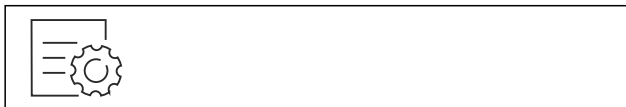

Fig. 149

Note

The settings menu access protection is activated. (see 6.2.7 Settings menu access protection)

- ▶ Enter the chosen PIN code. The settings menu opens.



Fig. 150

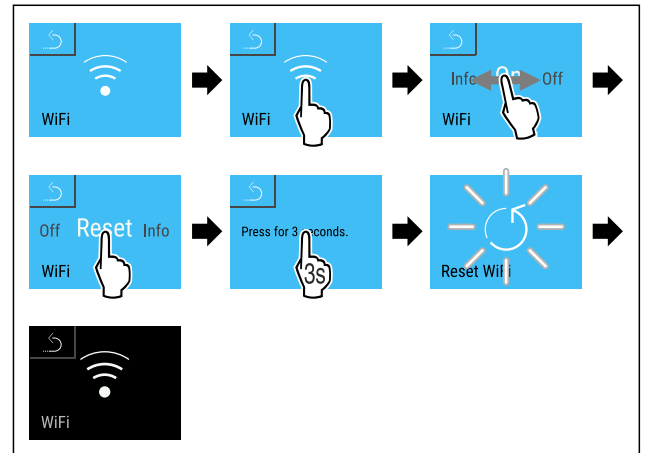

Fig. 151

- ▶ Carry out action steps according to the illustration.
- ▷ The WiFi settings are restored to the factory settings.

6.2.17 LAN connection



Note

Liebherr SmartMonitoring Dashboard is not available in all countries. Check availability via the QR code by entering your model.

Note

Use of the Liebherr SmartMonitoring Dashboard at <https://smartmonitoring.liebherr.com> requires installation of a SmartModule and a commercial MyLiebherr account. When commissioning online you can register using your login data, or register again and create a company account.

This setting establishes a wired connection between the appliance and the internet. The connection is controlled via the SmartModule. The appliance can be integrated via the browser-based [Liebherr SmartMonitoring Dashboard](#) and advanced options and customized methods relating to control, administration and monitoring can be used.

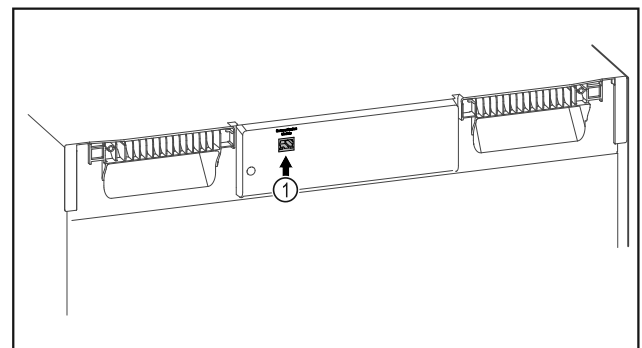

Fig. 152

Make sure that the following requirements are fulfilled:

- ❑ SmartModule Fig. 152 (1) is in use.
- ❑ A network cable is connected.
(The connection requires a network cable with a maximum length of 3 m (9.84 ft)).
- ❑ The network is connected to the Internet.

Establishing a connection

You commission and set up your SmartModule online via the [Liebherr SmartMonitoring Dashboard](#) on your web-enabled device.



Fig. 153

- ▶ Open [Liebherr SmartMonitoring Dashboard](#). (see Fig. 153)

On the fridge or freezer:



Fig. 154

Note

The settings menu access protection is activated. (see 6.2.7 Settings menu access protection)

- ▶ Enter the chosen PIN code. The settings menu opens.

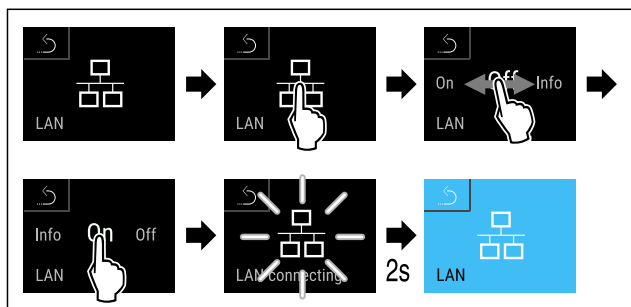

Fig. 155

- ▶ Carry out action steps according to the illustration.
- ▷ Connection is established: LAN connecting appears. The symbol flashes.
- ▶ Follow the [Liebherr SmartMonitoring Dashboard](#) instructions.
- ▷ Connection is established.

Disconnecting



Fig. 156

Note

The settings menu access protection is activated. (see 6.2.7 Settings menu access protection)

- ▶ Enter the chosen PIN code. The settings menu opens.

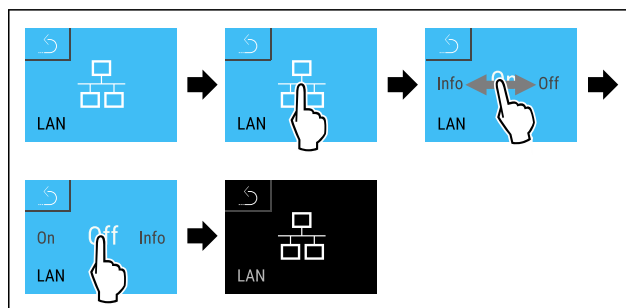

Fig. 157

- ▶ Carry out action steps according to the illustration.
- ▷ There is no connection.

6.2.18 Appliance information



Use this function to display the model name, index, serial number and service number of your appliance. You will need the appliance information when you contact customer service. (see 9.3 Customer Service)

You also use this function to open the expanded menu. (see 3 Functionality of the Touch & Swipe display)

Display appliance information



Fig. 158

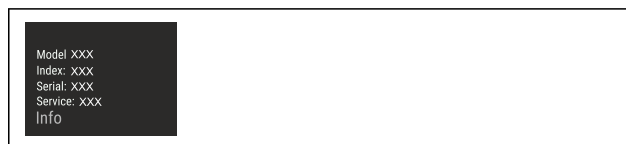

Fig. 159

- ▶ Carry out action steps according to the illustration.
- ▷ Display shows the appliance information.

6.2.19 Operating hours



The display shows the appliance operating hours.

Displaying operating hours



Fig. 160

Use



Fig. 161

▷ The operating hours appear.

6.2.20 Software



Use this function to display the software version of your appliance.

Display software version



Fig. 162



Fig. 163

▶ Carry out action steps according to the illustration.
▷ Display indicates the software version.

6.2.21 Defrosting



The appliance defrosts automatically in normal mode.

Application:

- If there is excessive ice in the interior, the defrosting function can be started manually.
- Only the cooling part is defrosted.

Manually starting automatic defrosting

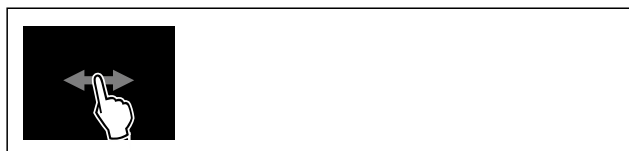

Fig. 164

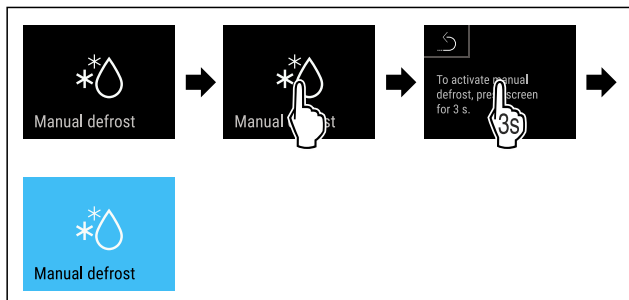

Fig. 165

▶ Carry out action steps according to the illustration.
▷ Automatic defrosting has been started. The appliance automatically switches back to normal mode once defrosting has finished.

Note

If there is still ice in the interior after starting automatic defrosting several times, defrost the appliance manually. (see 8.2 Defrosting the appliance)

Canceling manually started defrosting

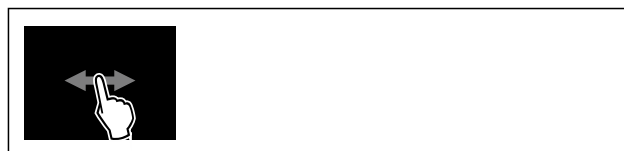

Fig. 166

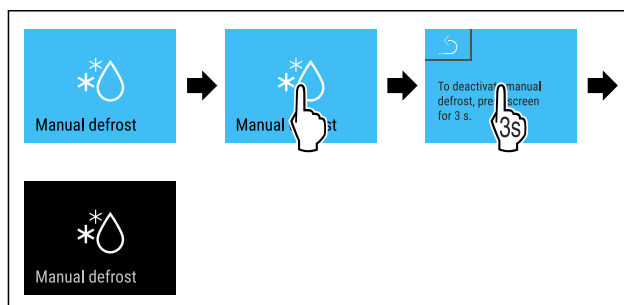

Fig. 167

▶ Carry out action steps according to the illustration.
▷ Manually started defrosting is canceled. The appliance automatically switches back to normal mode.

Defrosting info



This setting adjusts the display during an automatic defrosting process.

The following display variants are available:

- **Def 1:** The temperature display is not updated and shows the last temperature before automatic defrosting was started.
- **Def 2:** The “automatic defrosting” symbol is displayed on the status screen. The temperature display continuously updated and shows the actual temperature.
- **Def 3:** The temperature display continuously updated and shows the actual temperature.
- **Def 4:** The “automatic defrosting” symbol is displayed on the status screen. The temperature display is not updated and shows the last temperature before automatic defrosting was started.



Fig. 168 “Automatic defrosting process” symbol

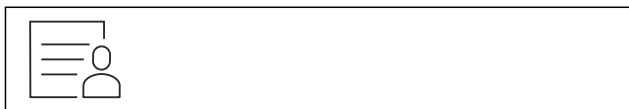

Fig. 169

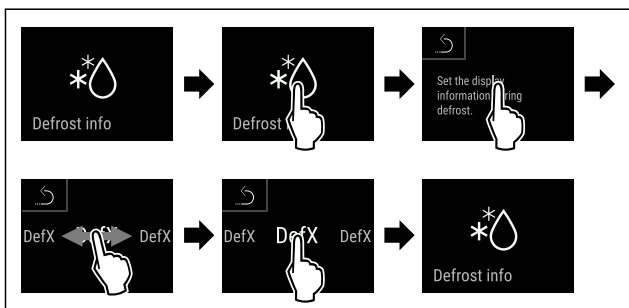

Fig. 170

- ▶ Carry out action steps according to the illustration.
- ▷ The desired display variant has been selected.

6.2.22 Data download / Datalogging



The appliance automatically records the entire temperature history of various sensors as well as alarm and service messages. The recording starts automatically after the appliance is switched on and records at one minute intervals. The data for the past 5 years is stored and can be downloaded onto a USB stick at any time.

The following data sets can be selected for download:

- Temperatures
- Alarms
- Service messages
- All

The selected data sets are stored in unencrypted format as text files over the entire recording period; these files have the extension „.log“.

Data download on USB stick

Note

Only USB memory sticks may be connected to the USB interface. USB hard drives are not detected.

Note

Do not remove the USB storage stick during the download procedure.

Make sure that the following requirements are fulfilled:

- USB 2.0 storage stick, FAT32 formatted.
- USB stick is connected.

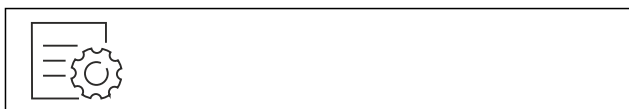

Fig. 171

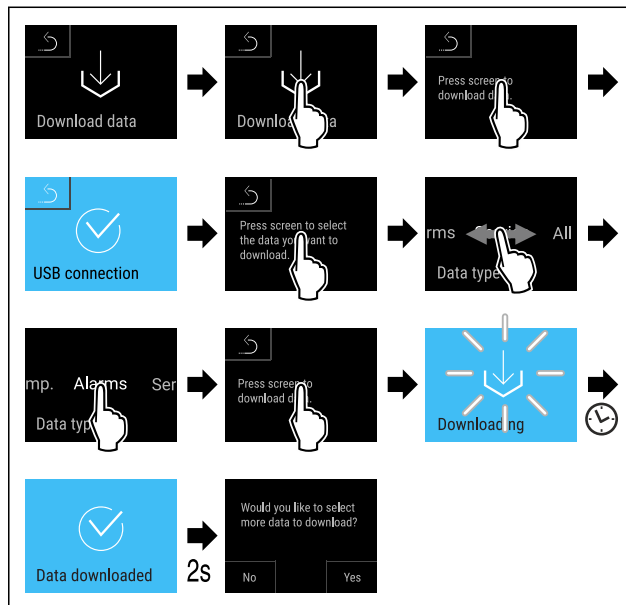
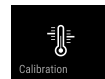

Fig. 172

- ▶ Carry out action steps according to the illustration.
- ▷ Successful data download on USB stick.
- ▷ It is possible to select and download further data sets.

6.2.23 Sensor calibration



The sensor calibration allows you to offset differences between the set and the actual temperature. To do so, determine the actual temperature using a calibrated measuring gauge.

Setting range for C sensor (control sensor): +/- 3 Kelvin in 0.1 Kelvin increments.

Setting range for P sensor (product sensor): +/- 9.9 Kelvin in 0.1 Kelvin increments

Calibrating sensor



Fig. 173

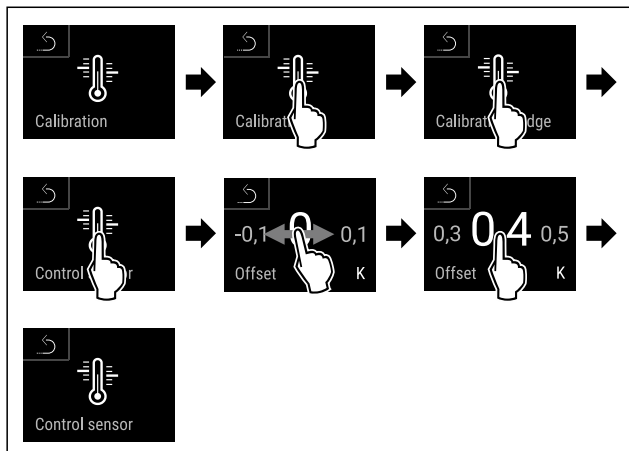

Fig. 174

- ▶ Carry out action steps according to the illustration.
- ▷ C sensor has been calibrated.

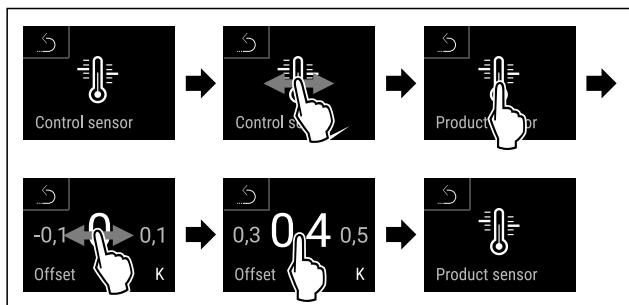

Fig. 175

- ▶ Carry out action steps according to the illustration.
- ▷ P sensor has been calibrated.

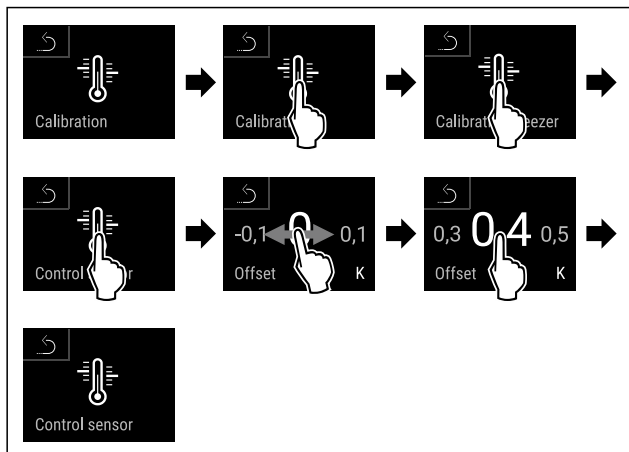

Fig. 176

- ▶ Carry out action steps according to the illustration.
- ▷ C sensor has been calibrated.
- ▷ Sensor calibration has been completed.

Note

The calibrated temperature is shown on the display within two hours.

6.2.24 Temperature alarm



Set the temperature alarm with this function. In the process, define the upper and lower temperature limit with a differential value to the currently set interior temperature. The temperature alarm is triggered once the interior temperature leaves the set temperature range and any set delay time has expired.

For example	Differential value to be set	
Current interior temperature	5 °C 41 °F	
Lower temperature limit	2 °C 36 °F	-3 °C 27 °F
Upper temperature limit	8 °C 46 °F	+3 °C 37 °F

You can set the following values:

- Differential value for lower temperature limit in 0.1 °C (°F) intervals
- Differential value for upper temperature limit in 0.1 °C (°F) intervals
- Alarm delay time from 0 to 60 minutes (a setting of “0” does not mean there is a delay in the temperature alarm.)
- Repetition frequency of the alarm from 0 to 30 minutes after confirming the alarm (setting of “0” means no repeated alarm after confirming the alarm relay.)

Setting fridge compartment temperature alarm



Fig. 177

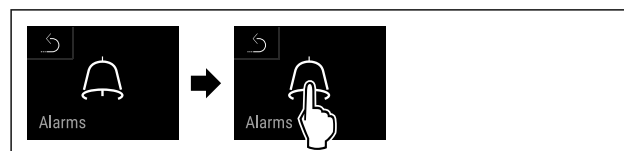

Fig. 178

- ▶ Carry out action steps according to the illustration.

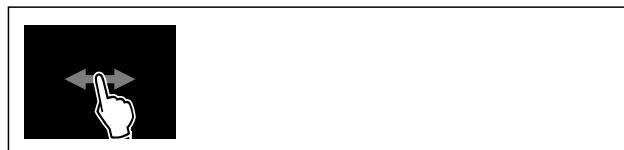

Fig. 179

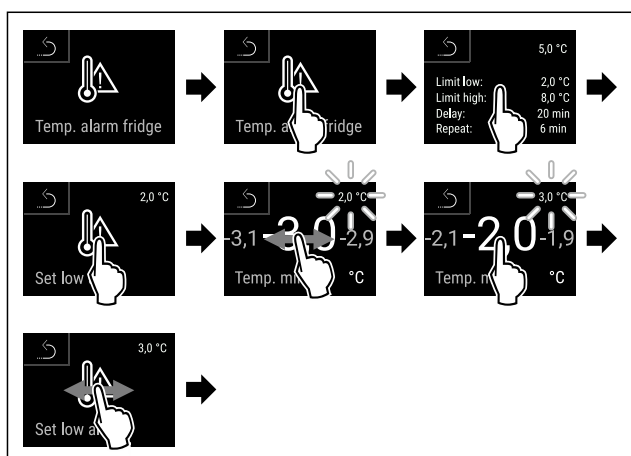

Fig. 180 Example for setting the lower temperature limit based on a set appliance temperature of 5 °C.

- ▶ Carry out action steps according to the illustration.
- ▷ Lower temperature limit has been set.

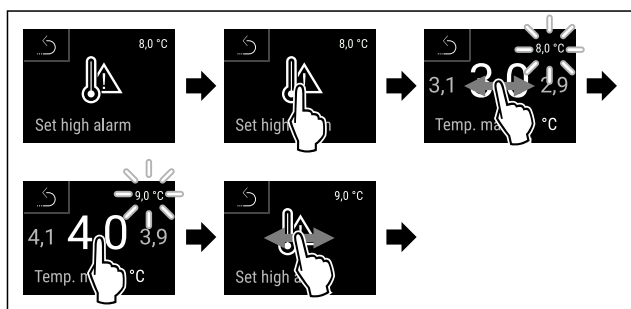

Fig. 181 Example for setting the lower temperature limit based on a set appliance temperature of 5 °C.

- ▶ Carry out action steps according to the illustration.
- ▷ Upper temperature limit has been set.

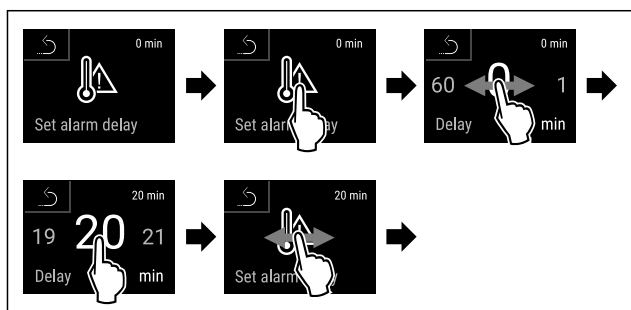

Fig. 182

- ▶ Carry out action steps according to the illustration.
- ▷ Alarm delay time has been set.

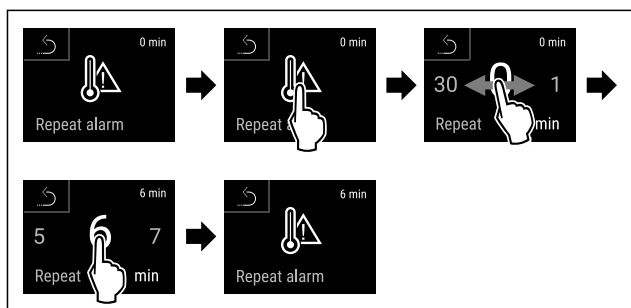

Fig. 183

- ▶ Carry out action steps according to the illustration.
- ▷ Alarm repetition interval has been set.
- ▷ Fridge compartment temperature alarm has been set.

Setting freezer compartment temperature alarm



Fig. 184

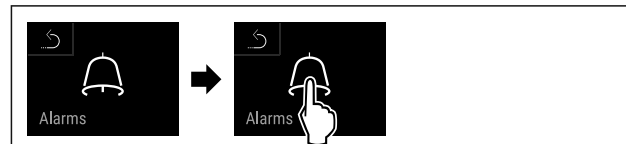

Fig. 185

- ▶ Carry out action steps according to the illustration.



Fig. 186

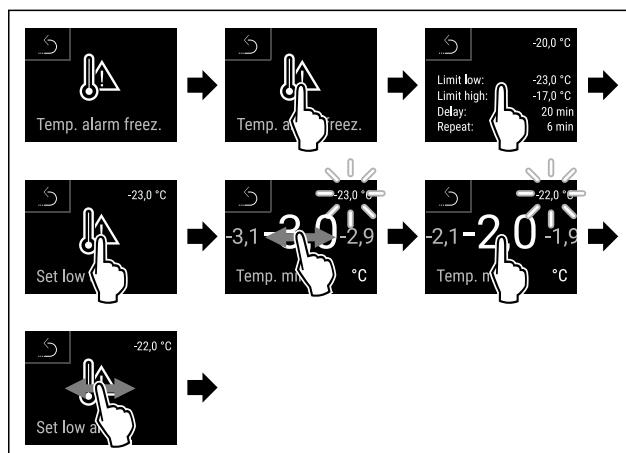

Fig. 187 Example for setting the lower temperature limit based on a set appliance temperature of -20 °C.

- ▶ Carry out action steps according to the illustration.
- ▷ Lower temperature limit has been set.

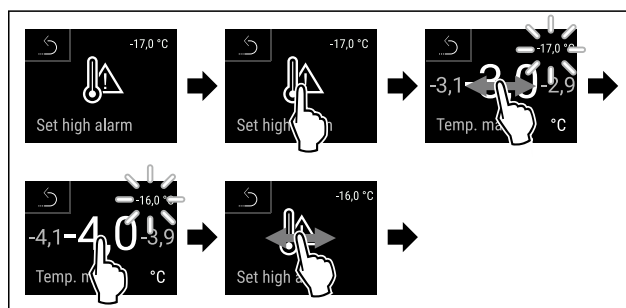

Fig. 188 Example for setting the lower temperature limit based on a set appliance temperature of -20 °C.

Use

- ▶ Carry out action steps according to the illustration.
- ▷ Upper temperature limit has been set.

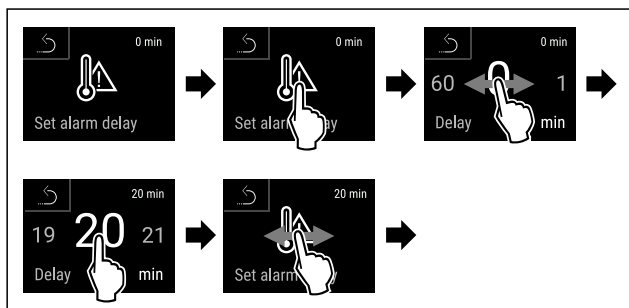

Fig. 189

- ▶ Carry out action steps according to the illustration.
- ▷ Alarm delay time has been set.

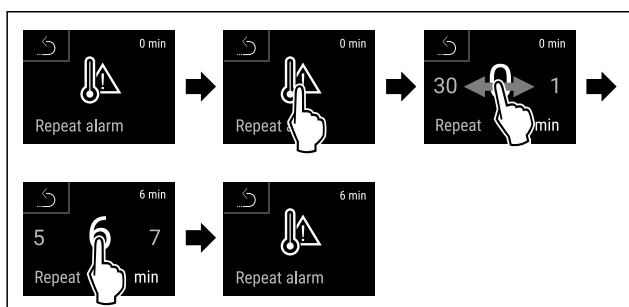

Fig. 190

- ▶ Carry out action steps according to the illustration.
- ▷ Alarm repetition interval has been set.
- ▷ Freezer compartment temperature alarm has been set.

Displaying set temperature alarm values for the fridge compartment



Fig. 191

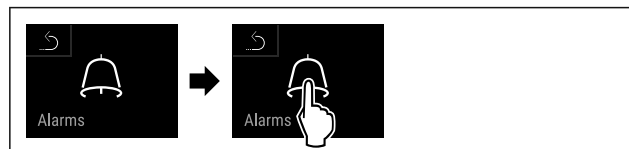

Fig. 192

- ▶ Carry out action steps according to the illustration.



Fig. 193

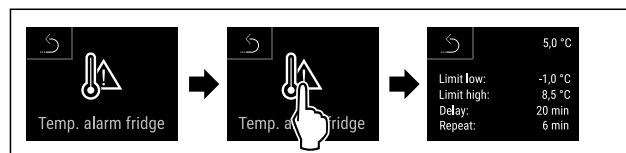

Fig. 194

- ▶ Carry out action steps according to the illustration.
- ▷ Set temperature alarm values for the fridge compartment are displayed.

Displaying set temperature alarm values for the freezer compartment



Fig. 195

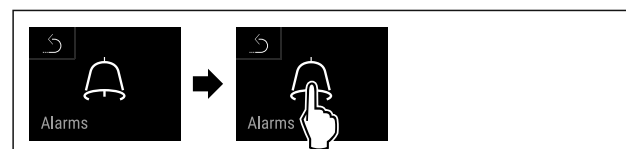

Fig. 196

- ▶ Carry out action steps according to the illustration.

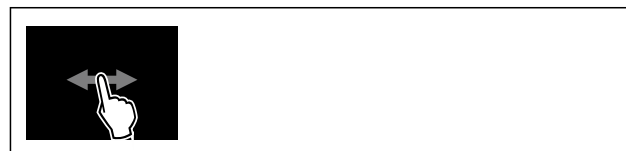

Fig. 197



Fig. 198

- ▶ Carry out action steps according to the illustration.
- ▷ Set temperature alarm values for the freezer compartment are displayed.

6.2.25 Door alarm

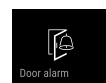

Use this function to activate or deactivate the door alarm. The door alarm sounds if the door is open for too long. The door alarm is activated upon delivery. You can set how long the door can remain open until the door alarm sounds.

You can set the following values:

- 15 seconds
- 30 seconds
- 60 seconds
- 90 seconds
- 120 seconds
- 150 seconds

- 180 seconds
- Off

Setting the door alarm



Fig. 199

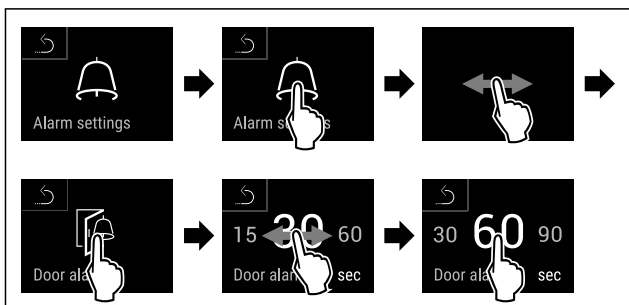

Fig. 201 Example illustration: Changing the door alarm from 30 seconds to 60 seconds.

- ▶ Carry out action steps according to the illustration.
- ▷ Door alarm is set.

Deactivating door alarm



Fig. 202

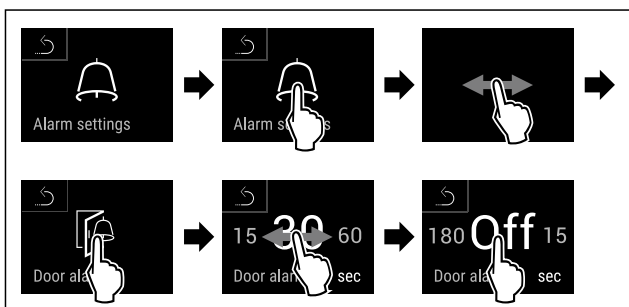

Fig. 203

- ▶ Carry out action steps according to the illustration.
- ▷ Door alarm is deactivated.

6.2.26 Light alarm



This setting allows the visual alarm messages in the display to also be emphasized by flashing appliance lighting.

Activating the light alarm



Fig. 204



Fig. 205

- ▶ Carry out action steps according to the illustration.



Fig. 206

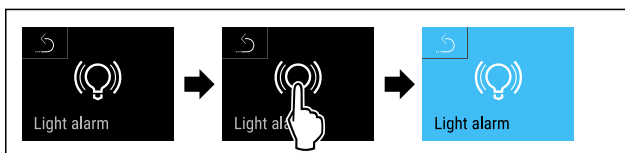

Fig. 207

- ▶ Carry out action steps according to the illustration.
- ▷ The light alarm is activated.

Deactivating the light alarm



Fig. 208

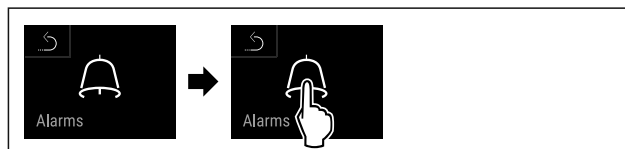

Fig. 209

- ▶ Carry out action steps according to the illustration.

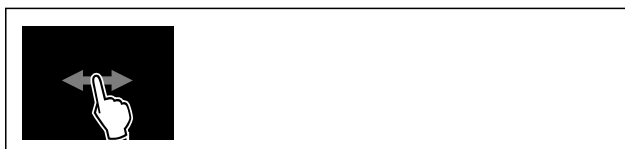

Fig. 210

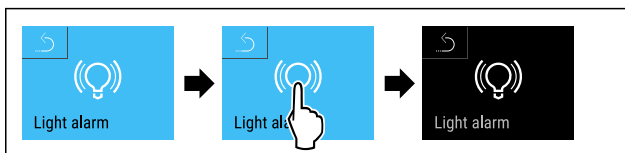

Fig. 211

- ▶ Carry out action steps according to the illustration.
- ▷ The light alarm is activated.

6.2.27 Alarm simulation



This function enables you to simulate a temperature alarm in the appliance, e.g. to check whether one of the safety devices triggers correctly. The safety device is connected to the potential-free alarm output. (see 7.5 Interfaces)

Starting the alarm simulation



Fig. 212



Fig. 213

► Carry out action steps according to the illustration.



Fig. 214

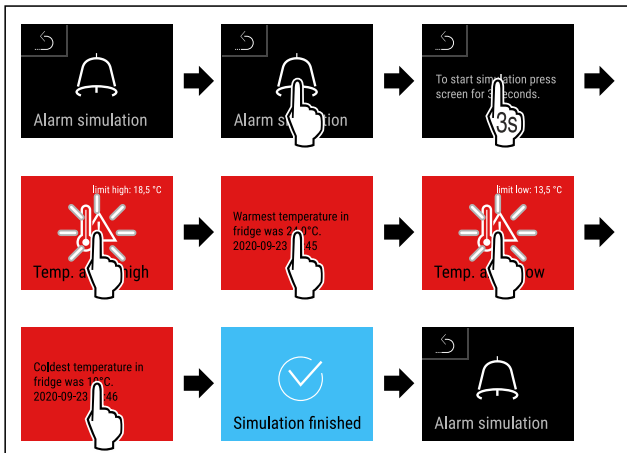
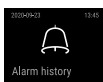

Fig. 215

► Carry out action steps according to the illustration.
 ▷ The simulation has been performed.
 ▷ Connected safety devices should have triggered.

6.2.28 Alarm log



This setting makes it possible to query and delete the last 10 alarms that have occurred on the device.

The following is displayed:

- Current date and time

- Active alarms (red).
- Past alarms, which have not yet been queried, are shown as **unconfirmed (red)**. Confirmation is given by swiping to the next error.
- Alarms, which have been queried, are shown as **confirmed**.
- Deletion of all alarms (including active and unconfirmed alarms).

Displaying alarm log and deleting an alarm



Fig. 216

-or-

► Via the display symbol at the bottom edge of the status display.

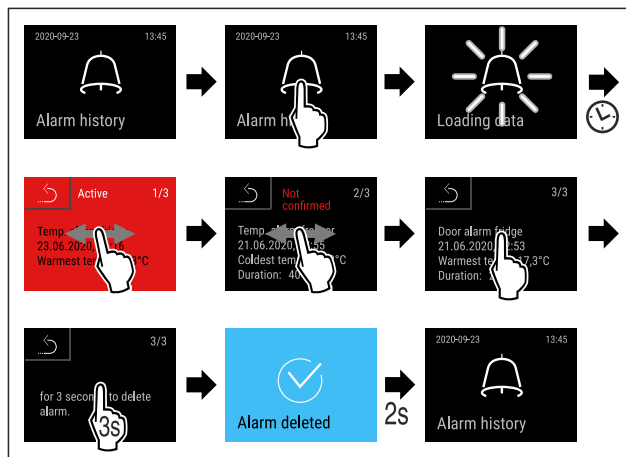

Fig. 217

► Carry out action steps according to the illustration.
 ▷ The querying and deletion of an alarm has been performed.

Displaying alarm log and deleting all alarms



Fig. 218

-or-

► Via the display symbol at the bottom edge of the status display.

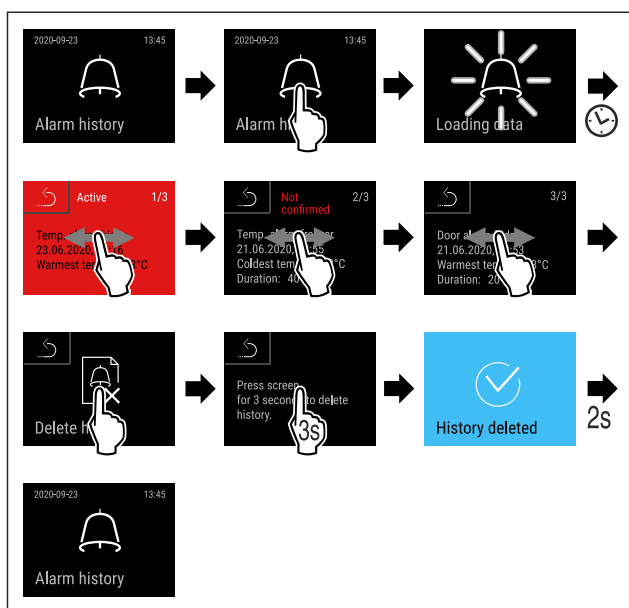
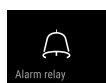

Fig. 219

- ▶ Carry out action steps according to the illustration.
- ▷ The querying and deletion of all alarms has been performed.

6.2.29 Alarm forwarding



This function enables you to set to have one or several alarms to be forwarded to an external alarm receiver. Here, the alarm receiver is connected to the appliance's potential-free alarm output. (see 7.5 Interfaces)

You can select from the following settings:

- Alarm type:
 - Door alarm
 - Temperature alarm
 - Door alarm and temperature alarm
 - All
- Confirm:
 - **Yes:** The alarm is confirmed on the appliance and the externally connected receiver.
 - **No:** The alarm is confirmed on the appliance and remains active on the receiver until the error is remedied.
- Update (only visible if you have selected "Yes" when you confirmed):
 - **Yes:** Alarm repeats.
 - Temperature alarm** depending on the set time (see 6.2.24 Temperature alarm)
(If you set the delay time of the alarm to "0", there will be no alarm repetition at the alarm relay either.)
 - Door alarm** after 1 or 4 minutes* (see 6.2.25 Door alarm)
 - **No:** Alarm permanently confirmed.

Activating alarm forwarding



Fig. 220

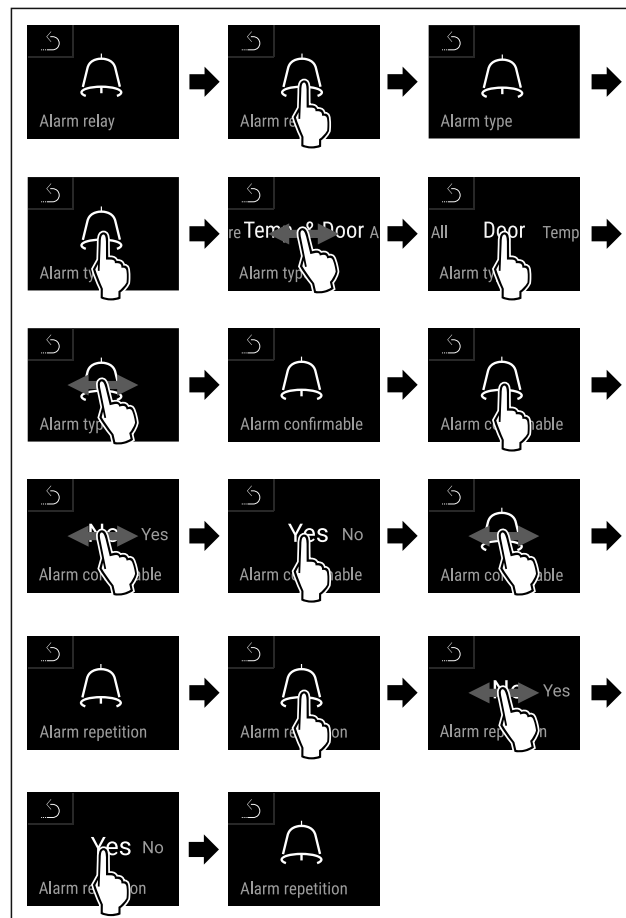
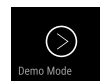

Fig. 221

- ▶ Carry out action steps according to the illustration.
- ▷ Alarm forwarding is set.

6.2.30 Demo mode



Demo mode is a special feature for dealers who want to demonstrate appliance features. If you activate demo mode, all refrigeration functions are deactivated. If you switch on your appliance and a "D" appears on the status display, demo mode is already activated. If you activate and then deactivate demo mode, the appliance will be reset to factory defaults. (see 6.2.31 Resetting to factory settings)

Activating demo mode



Fig. 222

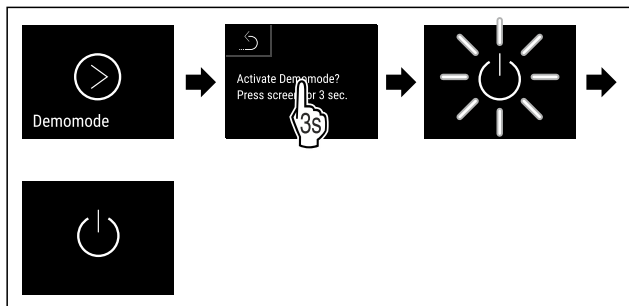

Fig. 223

- ▶ Carry out action steps according to the illustration.
- ▷ Demo mode is activated.
- ▷ Appliance is switched off.
- ▶ Switch on the appliance. (see 4.15 Switching on the appliance (first use))
- ▷ “D” appears in the status display.

Deactivating demo mode

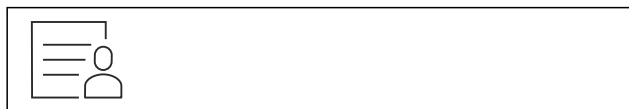

Fig. 224

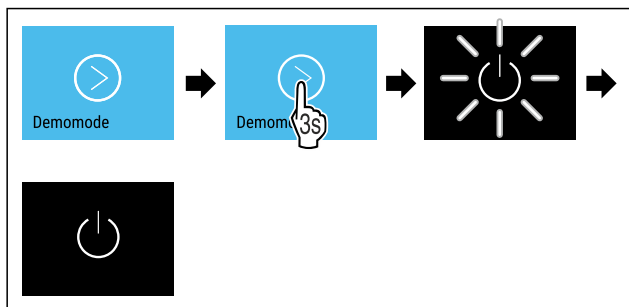



Fig. 225

- ▶ Carry out action steps according to the illustration.
- ▷ Demo mode is deactivated.
- ▷ Appliance is switched off.
- ▶ Switch on the appliance. (see 4.15 Switching on the appliance (first use))
- ▷ Appliance is reset to factory settings.

Message (red)	Cause	Remedy
 <p>Door open</p>	The message appears if the door is open for too long.	Close the door. Tap briefly. Alarm is stopped. Note The time until the message appears can be set. (see 6.2.25 Door alarm)

6.2.31 Resetting to factory settings



Use this function to reset all settings to factory settings. All settings you have made so far are reset to their original settings.

Performing a reset



Fig. 226

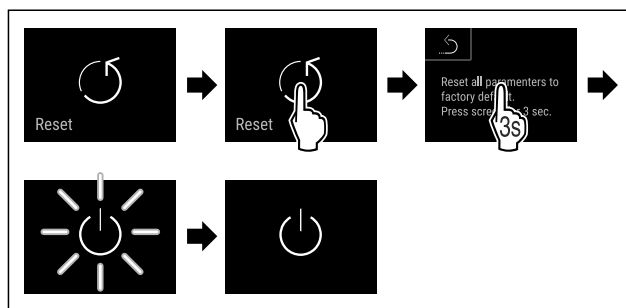

Fig. 227

- ▶ Carry out action steps according to the illustration.
- ▷ Appliance is reset.
- ▷ Appliance is switched off.

Note

Resetting to factory settings in battery mode: A restart is only possible with mains voltage.





- ▶ Restart the appliance. (see 4.15 Switching on the appliance (first use))



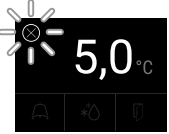
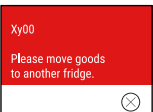
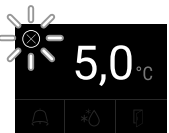

6.3 Messages

6.3.1 Warnings

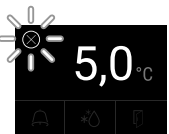
Warnings are issued by means of an audio signal and visually via a symbol on the display. The signal gets louder until the warning is acknowledged.

Message (red)	Cause	Remedy
 <p>Temperature alarm</p>	<p>This message appears if the temperature does not match the set temperature. Reasons for differences in temperature can be:</p> <p>Warm produce for cooling has been placed inside.</p> <p>Too much warm room air has flowed in during the rearrangement and removal of food.</p> <p>The power was cut off for a prolonged period.</p>	<p>Tap briefly.</p> <p>Information about errors and appliance status are displayed.</p> <p>Tap briefly.</p> <p>Warmest/coldest temperature, date and time are displayed.</p> <p>Tap briefly.</p> <p>The status screen is displayed.</p> <p>The current temperature and the alarm symbol flash red until the set temperature is reached.</p> <p>Check the quality of the refrigerated goods.</p>

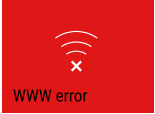

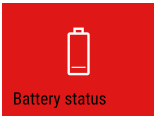
Message (red)	Cause	Remedy
 <p>Error</p>	<p>The appliance is malfunctioning, there is an appliance error or a component of the appliance has a fault.</p>	<p>Store refrigerated items elsewhere. Tap briefly. The error code (e.g. BT021) is displayed.</p>  <p>Tap briefly. A further error code is displayed if there is one</p>  <p>or Status screen is displayed with flashing error symbol.</p> <p>Swiping or tapping the display will show the error code(s) again. Make a note of error code(s) and contact Customer Service. (see 9.3 Customer Service)</p>
	<p>The message indicates unscheduled defrosting behavior. For example, the evaporator could ice up to an unusual extent due to prolonged door openings and the defrosting time may no longer be sufficient.</p>	<p>Tap briefly. DEFR.MAX is displayed.</p>  <p>Tap briefly. Status screen is displayed with flashing error symbol.</p>  <p>Swiping or tapping the display will show the message again. Store the cooled produce elsewhere and defrost the appliance by hand. Alternatively, defrosting can be started manually. (see 6.2.21 Defrosting) The flashing error symbol goes out after a long tap. If the message is displayed repeatedly and the causes listed do not apply, contact customer service. (see 9.3 Customer Service)</p>
	<p>The message indicates that freeze protection mode is active (e.g. due to frequent door openings or loading with goods).</p>	<p>Tap briefly. FRZ.PROT is displayed.</p>  <p>Tap briefly. Status screen is displayed with flashing error symbol.</p>  <p>Swiping or tapping the display will show the message again. The appliance automatically switches to normal operating mode after a few hours and the message disappears. Alternatively, the mode and message can be ended with a long tap. If the message is displayed repeatedly and the causes listed do not apply, contact customer service. (see 9.3 Customer Service)</p>

Message (red)	Cause	Remedy
 <p>Power failure</p> <p>Power failure</p>	<p>The message appears following an interruption to the electricity supply. The operating panel continues running in battery mode. All functions remain active except for refrigeration and lighting.</p>	<p>Tap briefly.</p> <p>Battery's state of charge, information about errors and appliance status are displayed</p> <p>Tap briefly.</p> <p>The warmest temperature and the time when there was a power outage are displayed.</p> <p>Tap briefly.</p> <p>The status screen is displayed.</p> <p>The current temperature and the alarm symbol flash red until the set temperature is reached.</p> <p>Check the quality of the refrigerated goods.</p>
 <p>WiFi error</p> <p>WiFi error</p>	<p>WiFi connection is interrupted.</p>	<p>Check connection.</p> <p>Press briefly.</p> <p>Alarm is stopped.</p>
 <p>WWW error</p> <p>WWW error, WiFi</p>	<p>This message appears if there is no internet connection via WiFi.</p>	<p>Check connection.</p> <p>Press briefly.</p> <p>Alarm is stopped.</p>
 <p>LAN error</p> <p>LAN error</p>	<p>LAN connection is interrupted.</p>	<p>Check connection and network cable.</p> <p>Press briefly.</p> <p>Alarm is stopped.</p>
 <p>WWW error</p> <p>WWW error, LAN</p>	<p>This message appears if there is no internet connection via LAN.</p>	<p>Check connection.</p> <p>Press briefly.</p> <p>Alarm is stopped.</p>
 <p>Battery status</p> <p>Battery error</p>	<p>Low appliance battery level (max. 20% remaining).</p>	<p>Reconnect the appliance to a power supply and check whether the battery charge level has increased after 12 hours. Otherwise contact Customer Service (see 9.3 Customer Service) or replace the battery. (see 8.4 Replacing appliance battery)</p> <p>Press briefly.</p> <p>Alarm is stopped.</p>

6.3.2 Reminders

Reminders appear when you are prompted to take action. They are issued by means of an audio signal and visually via a symbol on the display. Acknowledge the message by pressing the confirmation button.

Equipment

Message (yellow)	Cause	Remedy
 <p>Maintenance reminder</p>	The message appears when the timer for the set maintenance interval has expired.	Press briefly. Reminder is closed. Note The maintenance interval can be set (see 6.2.9 Maintenance interval reminder).
 <p>Logging reminder</p>	The message appears if the temperature recording memory (999 hours) is full.	Press briefly. Reminder is closed. The oldest data is overwritten. Note The temperature recording can be reset. (see 6.2.5 Temperature recording)
 <p>Alarm log</p>	The message appears if there are more than 10 unconfirmed alarm messages.	Press briefly. Check messages. Reminder is closed.

7 Equipment

7.1 Safety lock

The lock in the appliance door is equipped with a safety mechanism.

7.1.1 Locking appliance

Lock freezer compartment.

- ▶ Insert key.
- ▶ Turn key clockwise by 45°.
- ▷ The freezer compartment is locked.

Lock freezer and fridge compartment.

- ▶ Insert key.
- ▶ Turn key clockwise by 90°.
- ▷ The freezer and fridge compartment is locked.

7.1.2 Unlocking appliance

Unlock fridge compartment.

- ▶ Insert key.
- ▶ Turn key anticlockwise by 45°.
- ▷ The fridge compartment is unlocked.

Unlock freezer and fridge compartment.

- ▶ Insert key.
- ▶ Turn key anticlockwise by 90°.
- ▷ The freezer and fridge compartment is unlocked.

7.2 Safety lock

The appliance is fitted with an electronic lock.

Possible functions:

- Locking and unlocking the door lock using the door code.

7.2.1 Emergency unlocking

You can open the door can with the emergency release key if there is a power failure.

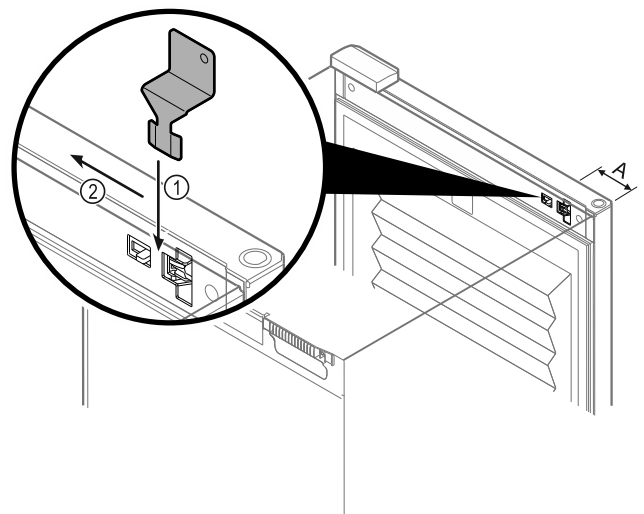

Fig. 228

- ▶ Insert the emergency release key in the specified position Fig. 228 (A) ≈ 100 mm (3 15/16 in).
- ▶ Insert the emergency release key Fig. 228 (1) from the top between the door and device body until it reaches the stop.
- ▶ Pull the emergency release key in the direction of the hinge. Fig. 228 (2)
- ▷ The lock is released. You can open the door.

7.3 Sensors

The appliance can be equipped with the following sensors for temperature monitoring:

- Safety thermostat sensor
- C sensor
- P sensor

7.3.1 Safety thermostat sensor

The safety thermostat sensor monitors the temperature drop and thus protects against excessively low temperatures (Freeze Protect). If the temperature drops below the threshold value, the appliance regulates the temperature automatically. The error message FRZ. PROT (Freeze Protect) (see 6.3 Messages) appears.

Note

Do not cover the safety thermostat sensor.

7.3.2 C sensor (control sensor)

The C sensor is permanently installed and regulates the interior temperature of the appliance. You can calibrate the C sensor if necessary. (see 6.2.23 Sensor calibration)

7.3.3 P sensor (reference sensor)

The P sensor is permanently installed in the interior and indicates the product temperature, which simulates the temperature of the chilled goods. The P sensor temperature is indicated on the status display as the actual temperature and the set alarm temperature limits refer to it. If necessary, the display of the P sensor can be calibrated. (see 6.2.23 Sensor calibration)

7.4 Sensor info



This function makes it possible to choose between C sensor or P sensor.

Make sure that the following requirement is met:

- P sensor is connected to the appliance. (see 7.5 Interfaces)

7.4.1 Selecting C sensor



Fig. 229

- ▶ Swipe left or right until corresponding function is displayed.

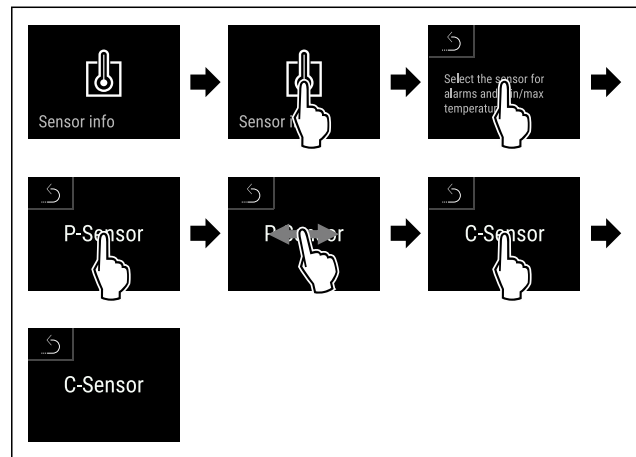

Fig. 230

- ▶ Carry out action steps according to the illustration.
- ▷ C sensor has been selected.

7.4.2 Selecting P sensor



Fig. 231

- ▶ Swipe left or right until corresponding function is displayed.

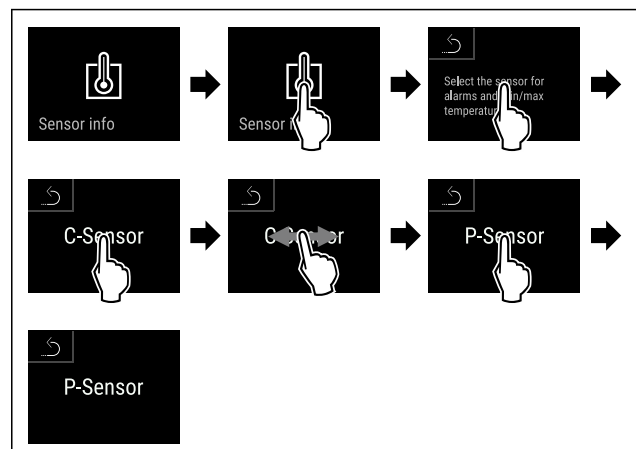

Fig. 232

- ▶ Carry out action steps according to the illustration.
- ▷ P sensor has been selected.

7.5 Interfaces

There are various connection options on the back of the appliance.

Maintenance

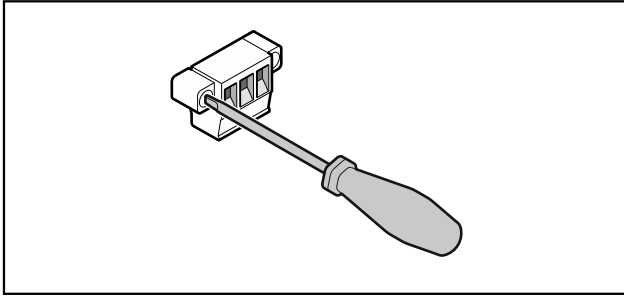

Fig. 233

Note

Screws secure the plugs. To enable disconnection of the plugs, loosen the screws on the left and right.

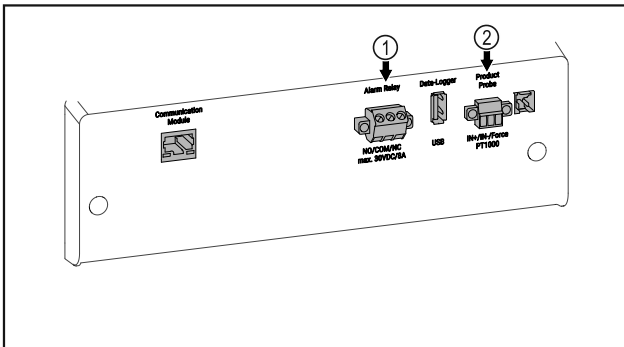

Fig. 234

- (1) Potential-free alarm output
- (2) Connection for P sensor

7.5.1 Potential-free alarm output



WARNING

Risk of injury due to electric shock!

- The appliance may only be connected to an external alarm device by trained specialist personnel.

These three contacts can be used to connect a visual or an acoustic alarm device. The connection is designed for a maximum of **30 V (DC) - 8 A** from a safety low voltage source SELV (**minimum current 150 mA**).

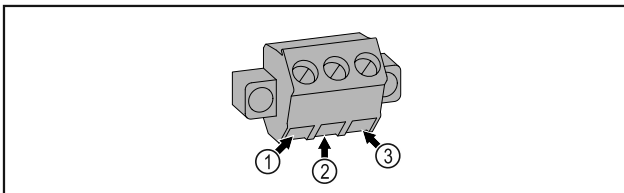

Fig. 235

- (1) NO (normally open)
Connection for indicator lamp, which is active in normal operation or when the appliance is switched off.
- (2) COM (common)
External voltage source

- (3) NC (normally closed)
Connection for alarm lamp or audible alarms, which is active when an alarm is triggered or lack of power supply.

7.5.2 Connection for P sensor

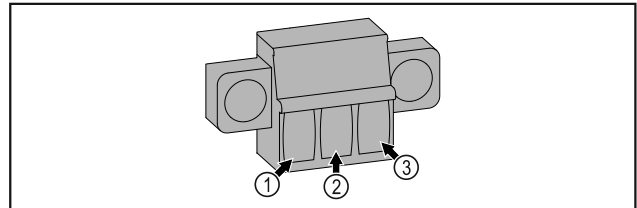

Fig. 236

- (1) IN+ (measuring line +)
- (2) IN- (common return line -)
- (3) FORCE (supply +)

8 Maintenance

8.1 Maintenance schedule

Maintenance work is to be performed at regular intervals to ensure proper appliance function.



CAUTION

Danger of injury and damage due to unprofessional maintenance work!

Personal injury and material damage.

- Maintenance work may only be performed by trained specialist personnel.



WARNING

Short-circuit hazard due to live parts!

Electric shock or damage to the electronics.

- **Switch off the appliance.**
- Pull out mains plug or switch off fuse.

Note

A maintenance reminder function can be activated. (see 6.2.9 Maintenance interval reminder)

Note

We recommend creating a maintenance log in which all work (repairs, checks) performed is documented.

Note

Liebherr recommends yearly maintenance. For an individual offer, please contact Customer Service (see 9.3 Customer Service) .

Component	Activity	Maintenance interval
Sheet metal parts	Check for damage and corrosion. Replace damaged parts: (see 9.3 Customer Service)	Yearly
Door, hinges	Check alignment (see 4.13 Aligning the door) , ease of movement, and tight fit.	Yearly
Lock, door handle *	Check for ease of movement and tight fit.	Yearly
Door seal	Check for damage, wear, and tight fit. A replacement door gasket is available via Customer Service (see 9.3 Customer Service) .	Yearly
Sensor	Calibrate sensor. (see 6.2.23 Sensor calibration)	Yearly
Sensor feedthrough	Check that the sealing compound is intact.	Yearly
Battery	Replace appliance battery. A replacement battery is available from customer service. (see 8.4 Replacing appliance battery)	5 to 10 years
Surfaces	Cleaning (see 8.3 Cleaning the appliance)	Recommendation: monthly or as required/specified at installation location
Surfaces	Disinfection Liebherr has tested the following disinfectants: Dismozon pur 1 % Lösung (Bode Chemie), Suma Quicksan (Diversey), Incidin Extra N (Ecolab Healthcare), Acrylan (Antiseptica chem.-pharm. Produkte), Buraton 10 F (Schülke und Mayr), Frankocid N (Franken Chemie), Apesin DSR 50 (Tana), Nüscosept Spray (Dr. Nüsken), Melsept SF (B. Braun Melsungen), Kohrsolin (Bode Chemie), Neoquat S (Dr. Weigert), Indicin Rapid (Ecolab Healthcare), Bacillocid Spezial (Bode Chemie), Neoform K Spray (Dr. Weigert), Apesin Desinf. Spray (Tana), Nüscosept 100 (Dr. Nüsken), Antisept T (Fink Tec), Apesin AP 100 0,50% Lösung (Tana), Perform Pulver 2% Lösung (Schülke und Mayr) Observe the operating instructions of the respective manufacturer. If disinfectants other than those stated are used, test them on a less exposed area first.	Recommendation: monthly or as required/specified at installation location

Maintenance

Component	Activity	Maintenance interval
Installation location, appliance	Decontamination The appliance is suitable for room decontamination with hydrogen peroxide H ₂ O ₂ . In this context, the values of the following application specifications must not be exceeded: Concentration: maximum 250 ppm. Humidity: maximum 85%. Maximum permissible room temperature as per climate class. (see 1.4 Range of appliance use)	Recommendation: as required/specified at installation location, maximum 2x per year
Fan air slots	Cleaning (see 8.3.3 Cleaning fan cover)	Yearly
Alarm relay Sensor	Check plug connections for tight fit.	Yearly
Power cable	Check for damage.	Yearly or if there is a change of location
Tilt angle	Check for proper function and tight fit.	Yearly or if there is a change of location
Adjusting feet/castors	Check for proper function, damage, and tight fit. Replace damaged parts. (see 9.3 Customer Service)	Yearly

8.2 Defrosting the appliance



WARNING

Appliance incorrectly defrosted!
Injuries and damage.

- ▶ Do not use mechanical devices or other means to accelerate the defrosting process, other than those recommended by the manufacturer.
- ▶ Do not use any electrical heating or steam cleaning equipment, naked flames or defrosting sprays.
- ▶ Do not remove ice with sharp objects.

Defrosting is performed automatically. The water from the defrosting process runs out via the drain opening and is evaporated.

To maintain the functionality of the appliance, we recommend defrosting it when there is a high buildup of ice. Icing in the interior is determined by the location (e.g. high humidity), settings on the appliance and incorrect user behavior.

If the automatic defrost cycle is not sufficient:

- ▶ Start the automatic defrost manually. (see 6.2.21 Defrosting)

If the problem persists, defrost the appliance manually:

- ▶ Switch off appliance. (see 6.2.2 Switching appliance on and off)
- ▶ Disconnect power plug.

- ▶ Store refrigerated items elsewhere.
- ▶ Leave the appliance door open during defrosting process.
- ▶ Soak up remaining defrost water with a cloth, clean the drain opening and the appliance.

8.3 Cleaning the appliance

8.3.1 Preparing



WARNING

Short-circuit hazard due to live parts!
Electric shock or damage to the electronics.

- ▶ **Switch off the appliance.**
- ▶ Pull out mains plug or switch off fuse.



WARNING

Danger of fire

- ▶ Do not damage the refrigerant circuit.

- ▶ Empty the appliance.
- ▶ Pull out the power plug.
- ▶ Observe the notes on appliance transport. (see 4.3 Transporting the appliance)

8.3.2 Cleaning the housing

NOTICE

Improper cleaning!
Damage to the appliance.

- ▶ Only use soft cleaning cloths and ph-neutral all-purpose cleaners.
- ▶ Do not use steel wool or sponges that scour or scratch.
- ▶ Do not use caustic or abrasive cleaning materials or those containing sand, chloride, or acids.



WARNING

Risk of injury or damage due to hot steam.
Hot steam can cause scalding/burns and damage to surfaces.

- ▶ Do not use steam cleaners.

NOTICE

Risk of damage due to short circuit.

- ▶ When cleaning the appliance, make sure no water gets into the electrical components.

- ▶ Wipe the housing down with soft, clean cloth. If very dirty, use lukewarm water with a neutral cleaner. Glass surfaces can also be cleaned with glass cleaner.
- ▶ Clean the condenser coil every year. If the condenser coil is not cleaned, this significantly reduces the efficiency of the appliance.

8.3.3 Cleaning fan cover

NOTICE

Risk of damage due to short circuit.

- ▶ When cleaning the appliance, make sure no water gets into the electrical components.

NOTICE

Improper cleaning!
Damage to the appliance.

- ▶ Only use soft cleaning cloths and ph-neutral all-purpose cleaners.
- ▶ Do not use steel wool or sponges that scour or scratch.
- ▶ Do not use caustic or abrasive cleaning materials or those containing sand, chloride, or acids.

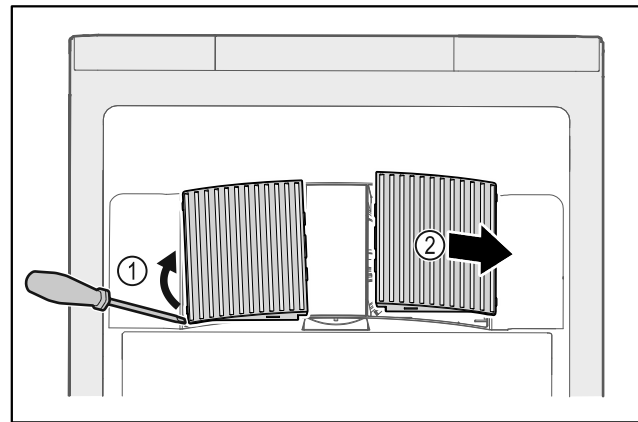

Fig. 237

- ▶ Carefully lever out fan covers from the side Fig. 237 (1) and remove towards the front Fig. 237 (2).
- ▶ Rinse the air slots of the fan covers under running water. If very dirty, use lukewarm water with a neutral cleaner.
- ▶ Leave fan covers to air-dry completely.
- ▶ Reattach fan covers to the appliance.

8.3.4 Cleaning the interior



WARNING

Short-circuit hazard due to live parts!
Electric shock or damage to the electronics.

- ▶ **Switch off the appliance.**
- ▶ Pull out mains plug or switch off fuse.



WARNING

Risk of injury or damage due to hot steam.
Hot steam can cause scalding/burns and damage to surfaces.

- ▶ Do not use steam cleaners.

NOTICE

Improper cleaning!
Damage to the appliance.

- ▶ Only use soft cleaning cloths and ph-neutral all-purpose cleaners.
- ▶ Do not use steel wool or sponges that scour or scratch.
- ▶ Do not use caustic or abrasive cleaning materials or those containing sand, chloride, or acids.

Note

- ▶ Defrost water drain (see 1.2 Overview of appliances and equipment) : Remove deposits using a thin object (e.g. a cotton bud).

Note

Do not damage or remove the type plate on the inside of the appliance. The type plate is important for Customer Service. (see 9.3 Customer Service)

Customer support

- ▶ Open the door.
- ▶ Empty the appliance.
- ▶ Clean the interior and equipment parts with luke-warm water and a little dish detergent. Do not use any gritty or acidic cleaning agent or any chemical solvent.

8.3.5 After cleaning

- ▶ Wipe the appliance and equipment parts dry.
- ▶ Connect and switch on appliance.
When the temperature is sufficiently cold:
- ▶ Place in items for refrigeration.
- ▶ Clean regularly.
- ▶ Clean the refrigeration machine with heat exchanger and remove dust from it once a year.

8.4 Replacing appliance battery

In the event of a power failure, the appliance battery is used to record temperature history, alarm and service messages and to show the alarm messages on the display for approximately 12 hours. During initial commissioning, the battery may take up to 24 hours to charge and be in proper working order.

A replacement battery is available from customer service (see 9.3 Customer Service).

8.4.1 Replacing the battery



WARNING

Short-circuit hazard due to live parts!
Electric shock or damage to the electronics.

- ▶ **Switch off the appliance.**
- ▶ Pull out mains plug or switch off fuse.

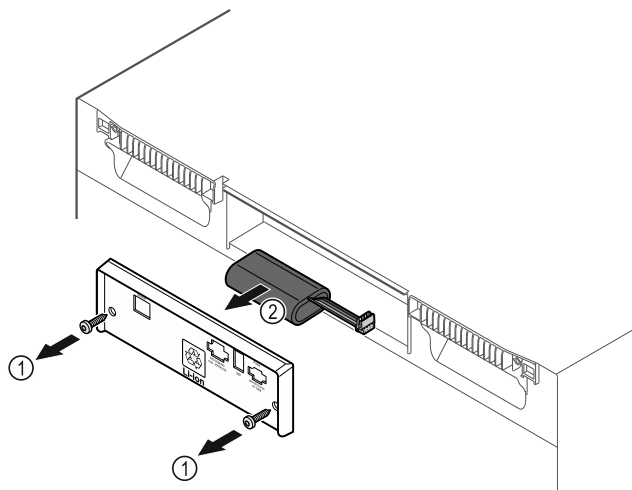

Fig. 238

- ▶ Unscrew screws and remove cover from the back of the appliance Fig. 238 (1).
- ▶ Disconnect and remove battery Fig. 238 (2).
- ▶ Install replacement battery.
- ▶ Close cover and screw in screws.
- ▶ Reconnect mains power cable.

Note

- ▶ The battery must be sent for separate waste treatment and disposed of properly and professionally in accordance with the locally applicable regulations and laws. **Do not damage or short circuit the battery!**

9 Customer support

9.1 Technical data

Temperature range	
Cooling	+3 °C (38 °F) to +16 °C (60 °F)
Freezing	-9 °C (15 °F) to -30 °C (-22 °F)

Maximum load per shelf ^{A)}		
Appliance width	600 mm (23 1/2 in)	750 mm (29 7/16 in)
Grid shelves	45 kg (99.21 lb)	60 kg (132 lb)
Glass shelf	40 kg (88.18 lb)	40 kg (88.18 lb)
Wooden grid shelf	45 kg (99.21 lb)	60 kg (132 lb)
Drawer	50 kg (110 lb)	50 kg (110 lb)

^{A)} Heavier loads may result in a slight bending of the shelves.

Net capacity
See net capacity on the type plate. (see 1.2 Overview of appliances and equipment)

Lighting	
Energy efficiency class ^{A)}	Light sources
This product contains one or more energy efficiency class F light sources	LED

^{A)} The appliance may contain light sources with different energy efficiency classes. The lowest energy efficiency class is indicated.

WLAN frequency specification	
Frequency band	2.4 GHz
Maximum radiated power	<100 mW
Purpose of the wireless equipment	Integration in the local WiFi network for data communication

Setup conditions	
Degrees of pollution (surrounding the appliance)	PD2
Ambient temperature	+10 °C (50 °F) to +35 °C (95 °F)
Maximum relative ambient moisture	75%, not condensing
Maximum operating elevation (meters above sea level)	2000 m (6,561.68 ft) 1500 m (4,921.26 ft) (glass door)

Electrical values	
Nominal voltage	115-127 V ~
Frequency	60 Hz
Connected load	2,0 A
Maximum power supply fluctuation	+/-10%
Overtoltage categories	II

Data according to DIN 13277 measured at a reference ambient temperature of +25 °C (77 °F)

Model	Energy consumption (kWh/24h)	Temperature increase in case of a power failure (min)	Temperature homogeneity (°K)	Temperature constancy (°K)
4002	1.300	100 (fridge sections) A)	1.7 (fridge sections) C)	1.9 (fridge sections) C)
		215 (freezer sections) B)	0.9 (freezer sections) C)	10.8 (freezer sections) C)
4032	1.541	75 (fridge sections) A)	2.3 (fridge sections) D)	3.1 (fridge sections) D)
		175 (freezer sections) B)	1.2 (freezer sections) D)	11.5 (freezer sections) D)

A) Heating of the reference unit: from +5 °C (41 °F) to +10 °C (50 °F) / reference unit: 100 ml (3.38 oz) (50 ml (1.69 oz) water, 50 ml (1.69 oz) isopropanol)

B) Heating of the reference unit: from a minimum temperature of -10 °C (14 °F) / reference unit: 50 ml (1.69 oz) isopropanol

C) Reference target temperature: +5 °C (41 °F)/-30 °C (-22 °F)

D) Reference target temperature: +5 °C (41 °F)/-25 °C (-13 °F)

Appliance battery	
Type	1S2P/NCR 18650BF
Nominal voltage	3.6 V DC
Capacity	6.7 Ah

9.2 Technical malfunction

Your appliance is designed and built to ensure it works reliably and has a long service life. If a malfunction nonetheless occurs during operation, please check whether the malfunction is due to an operating error. If this is the case, you will be charged for the cost incurred even if this falls within the warranty period.

You can rectify the following malfunctions yourself.

9.2.1 Appliance function

Defect	Cause	Remedy
The appliance is not working.	The appliance is not switched on.	► Switch on the appliance.

Customer support

Defect	Cause	Remedy
	The power plug is not properly inserted in the socket.	▶ Check the power plug.
	There is a problem with the wall socket breaker.	▶ Check the breaker.
	Power failure	▶ Keep the appliance closed. ▶ If necessary move the refrigerated/frozen items to another fridge or freezer if the power is off for a prolonged period.
	The IEC socket is not correctly plugged into the appliance.	▶ Check the IEC socket.
The temperature is not cold enough.	The appliance door is not closed properly.	▶ Close the appliance door.
	Ventilation is not sufficient.	▶ Unclog the ventilation grill and clean it.
	The ambient temperature is too high.	▶ Observe the suitable ambient conditions: (see 1.4 Range of appliance use)
	The appliance was opened too many times or for too long.	▶ Wait to see if the required temperature corrects itself. If not, contact Customer Service. (see 9.3 Customer Service)
	The temperature is set incorrectly.	▶ Set a colder temperature and check after 24 hours.
	The appliance is too close to a heat source (stove, heater etc).	▶ Move either the appliance or the heat source.
Frost forming on the housing frame and/or on the inside of the door.	Door seal is damaged.	▶ Replace the door seal.
	You have set the temperature too cold or you have not opened to door often enough.	▶ The appliance's functions are not impacted; use a cloth to remove the frost formation.

9.3 Customer Service

First check whether you can remedy the fault yourself. If this is not the case, please contact Customer Service.

You can find the address in the enclosed brochure "Liebherr-Service" or at home.liebherr.com/service.



WARNING

Unprofessional repair!
Injuries.

- ▶ A damaged power cable may only be replaced by the manufacturer, the manufacturer's Customer Service or a similarly qualified person.
- ▶ For appliances with plug and play connection cables, the change can be made by the customer.

9.3.1 Contacting Customer Service

Make sure you have the following appliance information ready:

- Appliance name (model and index)

- Service no. (service)

- Serial no. (S no.)

- ▶ Access the appliance information via the display (see 6.2.18 Appliance information).

-or-

- ▶ Refer to the type plate for appliance information. (see 9.4 Type plate)

- ▶ Note appliance information.

- ▶ Inform Customer Service: Report faults and the appliance information.

- ▷ This will help us to provide fast and focused service.

- ▶ Follow any further instructions provided by Customer Service.

9.4 Type plate

The type plate is inside the appliance. See appliance overview.

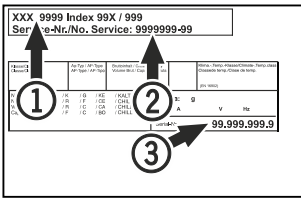

Fig. 239

- (1) Appliance designation
- (2) Service No.
- (3) Serial No.

10 Shutting down

- ▶ Empty the appliance.
- ▶ Switch off appliance.
- ▶ Pull the power plug from the outlet.
- ▶ If necessary, remove the IEC socket: Pull the IEC socket out of the appliance plug while turning it to the left and right at the same time.
- ▶ Clean the appliance. (see 8.3 Cleaning the appliance)
- ▶ If available: Remove the covers and insulation of the sensor feed-through to prevent mold from forming.
- ▶ Leave the door open so that no bad odors form.

Note

Damage to the appliance and malfunctions!

- ▶ After shutting down, only store the appliance at the permitted room temperature of between -10 °C (14 °F) and +50 °C (122 °F).

11 Disposal

11.1 Preparing the appliance for disposal



WARNING

Risk of child entrapment!

Before you throw away your old refrigerator or freezer:

- ▶ Take off the doors.
- ▶ Leave the shelves in place so that children may not easily climb inside.



Li-Ion

Liebherr uses batteries in some of its appliances. You should remove these before disposal of the old appliance for environmental reasons. If your appliance contains batteries, a corresponding notice is attached to the appliance.

Lamps If you can remove the lamps yourself without destroying them, also remove these before disposal.

- ▶ Take the appliance out of operation.
- ▶ Appliance with batteries: Remove the batteries. For description, see **Maintenance** chapter.
- ▶ If possible: Remove lamps without destroying them.

11.2 Disposing of the appliance in an environmentally friendly manner



The appliance still contains valuable materials and must be collected separately from unsorted municipal waste so it can be recycled.



Li-Ion



Li-Ion

Dispose of batteries separately from the old appliance. Certain batteries should NOT go in household garbage or recycling bins. Waste batteries can always be recycled or taken to household hazardous waste collection points. To prevent fires from lithium-ion batteries, tape battery terminals and/or place batteries in separate plastic bags and never put these batteries in household garbage or recycling bins.

Lamps

Dispose of removed lamps via the respective collection systems.

For USA:

Check the Responsible Appliance Disposal (RAD) program to find a RAD partner near you.

For Canada:

Follow your local guidance about recycling and disposal capabilities near you.



WARNING

Leaking refrigerant and oil!

Fire. The refrigerant contained within the appliance is environmentally friendly, but flammable. The oil contained within the appliance is flammable. Escaping refrigerant and oil can ignite if they are of high enough concentration and are exposed to an external heat source.

- ▶ Do not damage the pipelines of the coolant circuit and the compressor.

- ▶ Observe the notes on appliance transport. (see 4.3 Transporting the appliance)
- ▶ Transport the appliance away without damaging it.
- ▶ Dispose of batteries, lamps, and the appliance according to the above specifications.

12 Additional information

Further information on warranty conditions can be found in the enclosed service brochure or on the Internet at <https://home.liebherr.com>.

Additional information



Reference in the event of an appliance fault:

Model ID / Inventory number:

Quick Start Guide for everyday use

Information about using this Quick Start Guide:

- This Quick Start Guide is not a substitute for the full operating instructions nor is it a substitute for appliance training.
- This Quick Start Guide provides support for everyday use and handling the appliance.
- Read the full operating instructions and the safety instructions contained therein.

This quick start guide is for: SCFvh 40..



Using the QR code, you can read the full operating instructions.



Intended use

This laboratory refrigerator/freezer is suitable for professional storage of products at temperatures between 3 °C (38 °F) and 16 °C (60 °F) in the refrigerator compartment and between -9 °C (15 °F) and -30 °C (-22 °F) in the freezer compartment.

Foreseeable incorrect use

Do not use the appliance for the following applications:

- Storage and cooling of:
 - Chemically unstable, flammable or corrosive substances
 - Blood, plasma or other body fluids for the purpose of infusion, application or introduction in the human body
- Use in areas with risk of explosion
- Outdoor use or in areas where it is exposed to splash water or damp conditions

When stocking, observe the following points:

- Position grid shelves according to the height required.
- Observe maximum load.
- When the storage temperature has been reached, load the appliance (compliance with cold chain).
- Keep the ventilation slots of the recirculation fan free in the interior.
- Items for refrigeration must not come into contact with the evaporator on the rear wall.
- Keep liquids in closed containers.
- Leave space when storing items for refrigeration to ensure adequate air circulation.

Status display

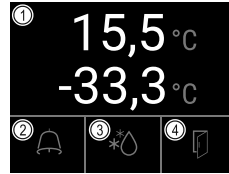

Fig. 240

- (1) Actual temperatures (2) Alarm status (3) Defrosting status (4) Door opening status

Displaying temperature recording

The temperature recording displays the length of the recording and the minimum and maximum temperatures measured during this period of time.



Fig. 241

Resetting temperature recording

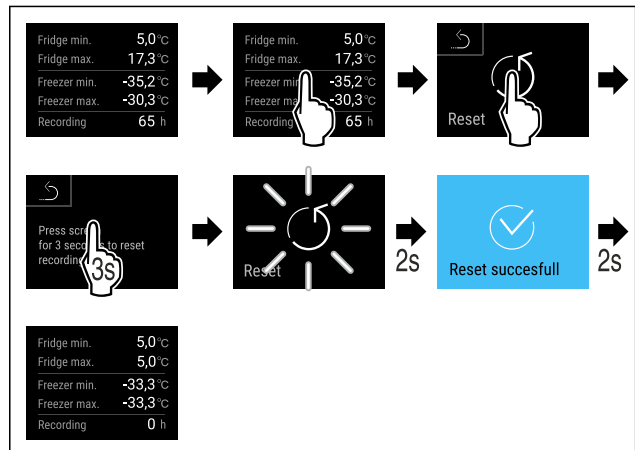

Fig. 242

Quick Start Guide for everyday use

Displaying alarm log

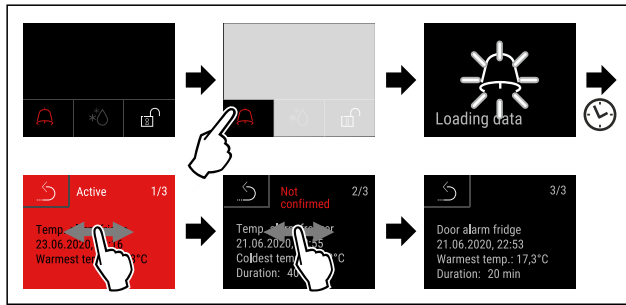

Fig. 243 Example shows an active alarm, an unconfirmed alarm, and a confirmed alarm.

- ▷ Alarm log shows active, confirmed or unconfirmed alarms (maximum 10 alarms).
- ▷ To delete the alarm log: See operating instructions.

Symbol color in the display	Meaning	Remedy
If you cannot remedy the fault yourself, contact a competent member of staff or your nearest customer service outlet.		

Cleaning appliance

- ▶ Empty the appliance.
- ▶ Pull out the power plug.
- ▶ Observe the information in the operating instructions.
- ▶ Dry the appliance and equipment thoroughly after cleaning.
- ▶ Connect the appliance.
- ▶ Switch on the appliance.
- ▶ Load the appliance once the storage temperature is reached.

What should I do if there is a fault?

A message appears in the display if there is a fault. Messages have different meanings:

Symbol color in the display	Meaning	Remedy
YELLOW	Reminder Reminder of general procedures. You can carry out these procedures to eliminate the message.	Consult the operating instructions and perform the troubleshooting steps.
RED	Warning Appears when there are malfunctions. You can eliminate simple malfunctions yourself.	Consult the operating instructions and perform the troubleshooting steps.



home.liebherr.com/fridge-manuals

EN Combined fridge-freezer
ORIGINAL OPERATOR'S MANUAL

Issue date: 20250306

Part number index: 7082950-00

For service in the United States and Canada: Liebherr Service Center
Toll Free: 1-844-542-6782
Email: service-commercial.us@liebherr.com
PlusOne Solutions, Inc.
3501 Quadrangle Blvd, Suite 120
Orlando, FL 32817