



Installation Guide

Quality, Design and Innovation



home.liebherr.com/fridge-manuals









LIEBHERR

General safety instructions

Contents

1	General safety instructions.....	2
2	Setup conditions.....	3
2.1	Space.....	3
2.2	Fitting the appliance into the kitchen unit....	3
2.3	Setting up multiple appliances.....	4
2.4	Electrical connection.....	5
3	Installation dimensions.....	5
4	Ventilation requirements.....	6
5	Connection dimensions for the power supply.....	6
6	Water connection.....	6
6.1	Water pressure.....	7
7	Transporting the appliance.....	7
8	Unpacking the appliance.....	7
9	Mounting wall spacers.....	7
10	Setting up the device.....	7
11	Setting up the appliance level.....	8
12	After setup.....	8
13	Disposal of packaging.....	8
14	Reversing the door.....	8
14.1	Taking off the top soft stop mechanism*.....	9
14.2	Removing the bottom soft stop damper*.....	10
14.3	Disconnecting the cable connection.....	12
14.4	Removing the top door.....	12
14.5	Removing the bottom door.....	13
14.6	Moving the upper bearing parts to the other side.....	13
14.7	Moving the central bearing parts to the other side.....	16
14.8	Moving the lower bearing parts to the other side.....	16
14.9	Moving the door bearing parts to the other side.....	17
14.10	Moving the handles to the other side.....	17
14.11	Fitting the bottom door.....	19
14.12	Fitting the top door.....	19
14.13	Fitting the cable connection.....	20
14.14	Aligning the doors.....	20
14.15	Fit the bottom soft stop mechanism.....	21
14.16	Fitting the top soft stop mechanism.....	21
15	Connecting the appliance to the water supply.....	22
15.1	Connecting the water pipe*.....	23
15.2	Check the water system.....	23
16	Connecting the appliance to the power supply.....	24

The manufacturer is constantly working to improve all types and models. Therefore, please be aware that we reserve the right to make changes to the shape, equipment and technology.

Symbol	Explanation
	Read instructions Please read the information in these instructions carefully to understand all of the benefits of your new appliance.
	Additional information online The digital manual with supplemental information can be found online by scanning the QR code on the front page of this manual or by entering the service number at home.liebherr.com/fridge-manuals .
	Check appliance Check all parts for transport damage. If you have any complaints, please contact your agent or customer service.
	Differences These instructions apply to a range of models, so there may be differences. Sections that apply to certain models only are indicated by an asterisk (*).
	Instructions and results Instructions are marked with a ▶. Results are marked with a ▷.
	Videos Videos about the appliances are available on the YouTube channel of Liebherr-Hausgeräte.

Open-source licenses:

The appliance includes software components that make use of open-source licenses. You can find information on the open-source licenses to be used here: home.liebherr.com/open-source-licenses

1 General safety instructions

- Please keep this assembly manual in a safe place so you can refer back to it at any time.
- If you pass the appliance on, please hand this assembly manual to the new owner.
- Read this assembly manual before installation and use in order to use the appliance safely and correctly. Follow the instructions, safety instructions and warning messages included at all times. They are important for ensuring you can operate and install the appliance safely and without any problems.
- First read the general safety instructions in the “General safety instructions” section of the **operating instructions**, which accompany these installation instructions, and

follow them. If you cannot find the **operating instructions**, you can download the **operating instructions** from the internet by entering the service number at home.liebherr.com/fridge-manuals. The service number can be found on the serial

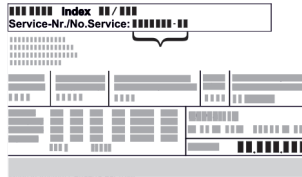

tag:

- **Observe the warning messages and other detailed information in the other sections when installing the appliance:**

	DANGER	indicates a hazardous situation, which if not avoided, will result in death or serious injury.
	WARNING	indicates a hazardous situation, which if not avoided, could result in death or serious injury.
	CAUTION	indicates a hazardous situation, which if not avoided, will result in minor or moderate injury.
	NOTICE	indicates a hazardous situation, which if not avoided, could result in damage to property.
	Note	indicates useful advice and tips.

2 Setup conditions

WARNING

Risk of fire due to moisture!

If live parts or the power cord get wet, this can cause a short circuit.

- The appliance is designed for use in enclosed spaces. Do not operate the appliance in open space or in damp areas or where there is spray.

Normal use

- Only set up and use the appliance in enclosed spaces.

2.1 Space

WARNING

Leaking refrigerant and oil!

Fire. The refrigerant contained within the appliance is environmentally friendly, but flammable. The oil contained within the appliance is flammable. Escaping refrigerant and oil can ignite if they are of high enough concentration and are exposed to an external heat source.

- Do not damage the pipelines of the coolant circuit and the compressor.

- If the appliance is installed in a very damp environment condensate water may form on the outside of the appliance.

Always ensure sufficient airflow and ventilation in the setup location.

- The more refrigerant there is in the appliance, the larger the space that it is installed in must be. If the space is too small, any leak may create a flammable mixture of gas and air. For every 8 g (0.28 oz) of refrigerant, the installation space must be at least 1 m³ (35.5 ft³). Specifications on the refrigerant in the appliance can be found on the serial tag plate inside the appliance.

2.1.1 Installation surface

- The floor of the installation site must be horizontal and level.
- The height of the appliance base must be the same as the surrounding floor.

2.1.2 Installation position

- Do not set up the appliance in an area with direct sunlight, next to a heating unit or similar.
- You can set up the appliance directly next to an oven.
- If you set up the appliance directly next to an oven, its energy consumption may increase slightly. This depends on the service life and how often the oven is used.
- Always stand the appliance backed directly to the wall using the enclosed wall spacers (see below).

2.2 Fitting the appliance into the kitchen unit

You can install kitchen cabinets around the appliance.

Setup conditions

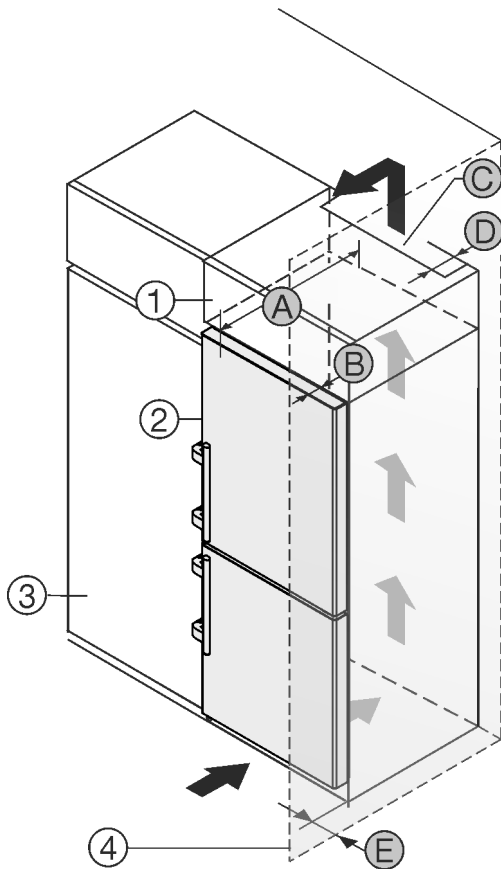

Fig. 1

(1) Top cabinet
(2) Appliance

(3) Kitchen cabinet

(4) Wall

(A) Appliance depth

(B) Door depth

(C) Ventilation cross-section

(D) Distance to the rear of the appliance

(E) Distance to the side of the appliance

You can place the appliance directly beside the kitchen cabinet Fig. 1 (3).

There must be a ventilation shaft at the depth Fig. 1 (D) of the back of the top cupboard over the entire width of the top cupboard.

The cross section of the ventilation gap Fig. 1 (C) must be maintained below the ceiling.

If the appliance is set up with the hinges next to a wall Fig. 1 (4), the distance between the appliance and the wall must be at least 57 mm (2 1/4 in) . This is how far the handle protrudes when the door is open.

In order to be able to fully open the door, the appliance must protrude by the depth of the door Fig. 1 (B) from the front of the kitchen cabinet. Regardless of the depth of the kitchen cabinets Fig. 1 (3) and use of wall spaces, the appliance can protrude further.

Appliances with lever handle:

A	675 mm (26 9/16 in) *
---	-----------------------

Appliances with lever handle:

B	75 mm (2 15/16 in)
C	Min. 300 cm ² (46.5 in ²)
D	mind. 50 mm (1 15/16 in)
E	Min. 57 mm (2 1/4 in)

* The use of wall spacers increases the dimensions by 15 mm (5/8 in) (see 9 Mounting wall spacers) .

Note

A set for restricting the door opening angle to 90° can be acquired from Customer Services for appliances with soft closing.

Ensure that the following conditions are met:

- Recess dimensions are adhered to .
- Ventilation requirements are complied with (see 4 Ventilation requirements) .

2.3 Setting up multiple appliances

The appliances were developed for different installation options. If you want to install several appliances side by side or on top of each other, make sure that the following requirements are met:

- Only install those appliances side by side or on top of each other that were developed for the purpose.
- Observe the instructions and the following table.

NOTICE

Risk of damage caused by water condensate!

- ▶ Do not set up the appliance next to another refrigeration/freezer unit.

Model	Installation type
All models	individually
Models with a model designation that starts with S...	Side-by-side (SBS)

3 Installation dimensions

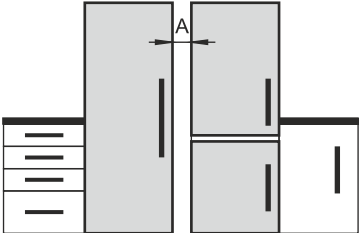
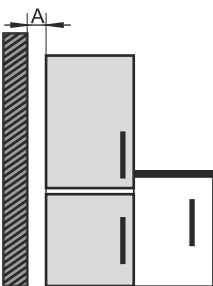
Model	Installation type
Models without side wall heating	 <p>Next to each other: Install with a distance A from 70 mm (2 3/4 in) between the appliances.</p> <p>Next to each other: Install with a distance A from 100 mm (3 15/16 in) between the appliances.</p> <p>If you do not keep this distance, condensate can form on the side walls between the appliances.</p>  <p>At an outside wall: Install with a distance A as for a side-by-side installation.</p> <p>If you do not keep this distance, condensate can form on the side wall of the appliance.</p>

Models and their installation type

Assemble the appliances according to the separate assembly instructions.

2.4 Electrical connection



WARNING

Danger of fire due to incorrect positioning!

If the power supply cable or plug touches the back of the appliance, the vibration can damage the power supply cable or the plug resulting in a short circuit.

- ▶ Make sure the power supply cable is not trapped under the appliance when you position the appliance.
- ▶ Install the appliance so that it does not touch any plugs or power cables.
- ▶ Do not connect any appliances to sockets in the area of the back of the appliance.
- ▶ Do **not** place and operate power strips/power distributors and other electronic devices (such as halogen transformers) at the back of the appliances.

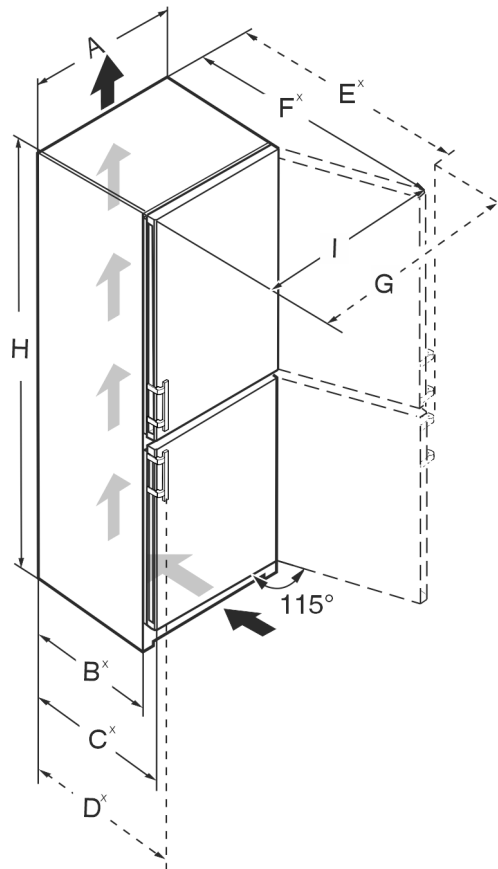

Fig. 2

C5250	
H	1855 mm (73 1/16 in)
A	597 mm (23 1/2 in)
B	611 mm (24 1/16 in) ^x
C	675 mm (26 9/16 in) ^x
D	719 mm (28 5/16 in) ^x
I	846 mm (33 5/16 in)
G	882 mm (34 3/4 in)
F	1178 mm (46 3/8 in) ^x
E	1186 mm (46 11/16 in) ^x
SC5781 / SCB5790IM	
H	2015 mm (79 5/16 in)
A	597 mm (23 1/2 in)
B	611 mm (24 1/16 in) ^x
C	675 mm (26 9/16 in) ^x
D	719 mm (28 5/16 in) ^x
I	846 mm (33 5/16 in)

Ventilation requirements

SC5781 / SCB5790IM	
G	882 mm (34 3/4 in)
F	1178 mm (46 3/8 in) ^x
E	1186 mm (46 11/16 in) ^x

SC7751 / SCB7760IM	
H	2015 mm (79 5/16 in)
A	747 mm (29 7/16 in)
B	610 mm (24 1/16 in) ^x
C	675 mm (26 9/16 in) ^x
D	719 mm (28 5/16 in) ^x
I	1059 mm (41 11/16 in)
G	1096 mm (43 2/16 in)
F	1314 mm (51 3/4 in) ^x
E	1322 mm (52 1/16 in) ^x

CB7790IM	
H	2015 mm (79 5/16 in)
A	747 mm (29 7/16 in)
B	610 mm (24 1/16 in) ^x
C	675 mm (26 9/16 in) ^x
D	–
I	1059 mm (41 11/16 in)
G	–
F	1314 mm (51 3/4 in) ^x
E	–

^x For appliances with supplied wall spacers, the dimension must be increased by 15 mm (5/8 in) (see 9 Mounting wall spacers).

4 Ventilation requirements

NOTICE

Risk of damage due to overheating in the case of insufficient ventilation!

In the case of insufficient ventilation, the compressor can be damaged.

- ▶ Make sure there is sufficient ventilation.
- ▶ Observe the ventilation requirements.

If the appliance is integrated in a fitted kitchen, the following ventilation requirements must be met:

- Basically, the larger the ventilation gap, the more energy the appliance saves during operation.

5 Connection dimensions for the power supply

The connection for the power supply is on the rear of the appliance. In order for you to be able to safely connect your appliance, make sure that the following requirements are met:

- ❑ Dimensions for the power supply connection are known and observed. See the table below.
- ❑ The connection to the power supply is made according to the instructions. (see 16 Connecting the appliance to the power supply)

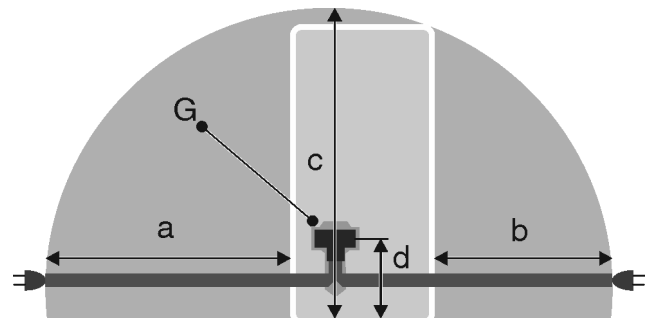

Fig. 3 Fridge/freezer combinations/freezers/full-capacityBio-Fresh appliances

- (a)** Maximum available length of the power cable
- (b)** Maximum available length of the power cable
- (c)** Maximum available vertical length of the power cable
- (d)** Distance of the appliance plug to the floor
- (G)** Appliance plug

For 600 mm (23 1/2 in) wide appliances:*	
a	~ 1800 mm (70 7/8 in)
b	~ 1400 mm (55 1/8 in)
c	~ 2100 mm (82 11/16 in)
d	~ 200 mm (7 7/8 in)

For 750 mm (29 7/16 in) wide appliances:*	
a	~ 1725 mm (67 15/16 in)
b	~ 1325 mm (52 3/16 in)
c	~ 2100 mm (82 11/16 in)
d	~ 200 mm (7 7/8 in)

6 Water connection

If your appliance has a fixed water connection, an elbow connector with screen filter is supplied with it.*

Transporting the appliance

Requirements for the water pressure:	(see 6.1 Water pressure)
Make the water connection:	(see 15 Connecting the appliance to the water supply)

6.1 Water pressure

The water connection line and solenoid valve of the appliance are suitable for a water pressure of up to 1 MPa (10 bar (145.04 psi)).

To ensure that the appliance functions correctly (flow rate, ice cube size, noise level), maintain the following water pressure:

Water pressure:*		
bar*	psi*	MPa*
1.5 to 6.2	21.76 to 87.02	0.15 to 0.62

If the pressure is higher than 6.2 bar (89.92 psi):

- ▶ Connect a pressure reducer.
- ▶ Make the water connection. (see 15 Connecting the appliance to the water supply)

7 Transporting the appliance

Observe the following when transporting the appliance:

- ▶ Transport the appliance upright.
- ▶ Use two people when transporting the appliance.

During the first use:

- ▶ Transport the appliance packaged.

During appliance transport or at first use (e.g. when moving or cleaning):

- ▶ Empty the appliance.
- ▶ Secure the door against undesired opening.

8 Unpacking the appliance

If the appliance is damaged check with the supplier immediately before connecting it.

- ▶ Check the appliance and packaging for damage during transport. If you suspect any damage, please contact your supplier immediately.
- ▶ Remove all materials that could prevent it from being installed properly or prevent proper ventilation from the back or the side panels of the appliance.
- ▶ Remove all protective films from the appliance. Do not use sharp or pointed objects for this.

9 Mounting wall spacers

With the wall spacer, your appliance will achieve the specified energy consumption and no condensation will form in high ambient humidity. The appliance will work properly without using the wall spacer, but with a slightly higher energy consumption.

If you use the wall spacer, the appliance depth increases by approx. 15 mm (5/8 in).

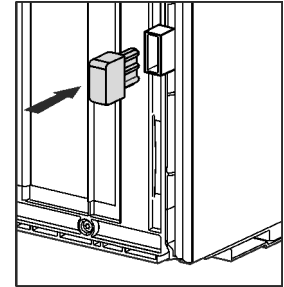

- ▶ Appliance with the wall spacer brackets provided: Install the wall spacer bracket on the rear side of the appliance on the left and right.

10 Setting up the device



CAUTION

Risk of injury due to heavy appliance!

- ▶ Have two people transport the appliance to its installation site.



WARNING

Risk of fire from short circuit!

- ▶ When setting up the appliance: Do not kink, trap, or damage the power cable.
- ▶ Do not operate the appliance with a defective power cable.



WARNING

Danger of injury and damage due to the appliance being unstable!

The appliance can tip over.

- ▶ Secure the appliance as described in the instructions.



WARNING

Danger of fire and damage!

- ▶ Do not place devices that give off heat, e.g. microwaves, toasters, etc. on the appliance.

Make sure that the following requirements are fulfilled:

- Only move the appliance when it is not loaded.
- Always install the appliance with help.
- ▶ Remove the power cable from the enclosed package.
- ▶ Fully insert the IEC socket of the power cable completely into the appliance plug on the rear side of the appliance. Ensure the IEC socket is firmly in place.
- ▶ If necessary, use a string to route the power plug to a socket outlet that is freely accessible.

Setting up the appliance level

11 Setting up the appliance level

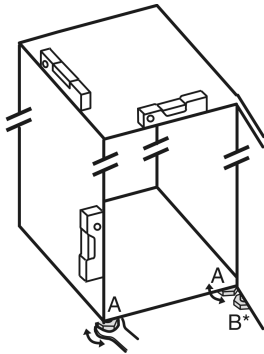

Fig. 4

- ▶ Unscrew the adjustable feet Fig. 4 (A) using the open-end wrench provided and a spirit level until the appliance is firmly aligned and level.



CAUTION

Risk of injury or damage from the appliance tipping or the door falling open!*

If the additional adjustable foot on the base support is not correctly positioned on the floor, there is a risk of the door falling open or the appliance tipping. This can lead to injury or property damage.

- ▶ Unscrew the additional adjustable foot on the swap bearing block as per the instructions.
- ▶ Unscrew the adjustable foot Fig. 4 (B) at the swap bearing block using the open-end wrench provided until it rests on the floor.
- ▶ Turn the adjustable foot Fig. 4 (B) another 90°.
- ▷ Appliance is aligned.

12 After setup

- ▶ Pull off the protective film from the outside of the housing.
- ▶ Pull off the protective film from the trim strips.
- ▶ Pull off the protective film from the trim strips and drawer fronts.
- ▶ Take off the protective film from the stainless steel rear panel.
- ▶ Remove all transport packaging.
- ▶ Clean the appliance. (see operating instructions)
- ▶ Note the type (model, number), appliance designation, appliance/serial number, purchase date and dealer's address.

13 Disposal of packaging



WARNING

Danger of suffocation from packaging materials and films!

- ▶ Do not allow children to play with packaging materials.

The packaging is made from recyclable materials:

- Corrugated card/cardboard
 - Parts made of foamed polystyrene
 - Films and bags from polyethylene
 - Packing bands from polypropylene
 - Wood frame nailed together with a polyethylene window*
- ▶ Take the packaging material to an official collection point.

14 Reversing the door

Tools



Fig. 5

NOTICE

Risk of damage due to colliding doors!

Damage to the appliances if set up Side-by-Side. If you set up two appliances in a specific Side-by-Side arrangement, the door hinges of both appliances are specified from the factory.

- ▶ Side-by-Side setup: Do not change the door hinge.

These sections apply for appliances **with a soft stop mechanism**:

- For appliances **with** a soft stop mechanism
- For all appliances

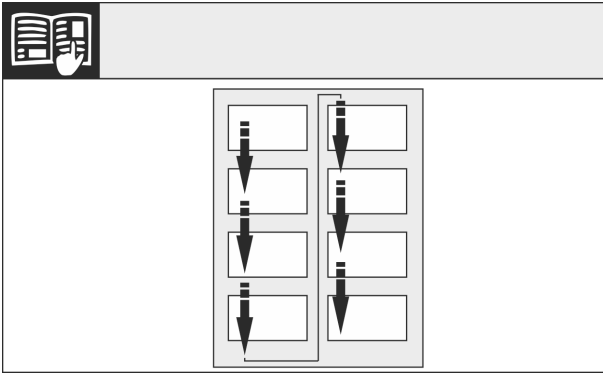

Fig. 6
Observe the reading direction.

14.1 Taking off the top soft stop mechanism*

For appliances with soft stop mechanism:*

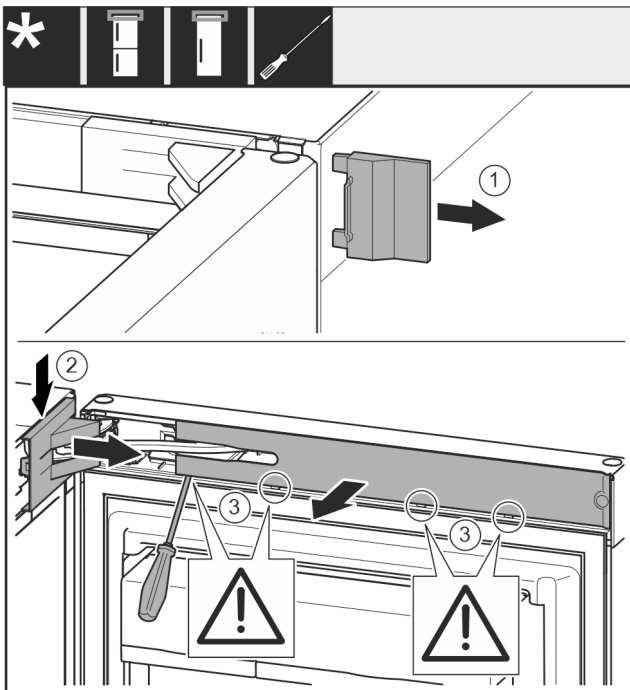

Fig. 7
▶ Open the top door.

NOTICE

Risk of damage!
If the door seal is damaged the door may not close properly and the level of cooling is insufficient.

▶ Do not damage the door seal with the screwdriver!

- ▶ Remove the cover Fig. 7 (1).
- ▶ Snap out the swap bearing block cover Fig. 7 (2) and loosen it.
- ▶ Take off the swap bearing block cover Fig. 7 (2).
- ▶ Use a slotted screwdriver to snap out the faceplate Fig. 7 (3) and swivel it to the side.

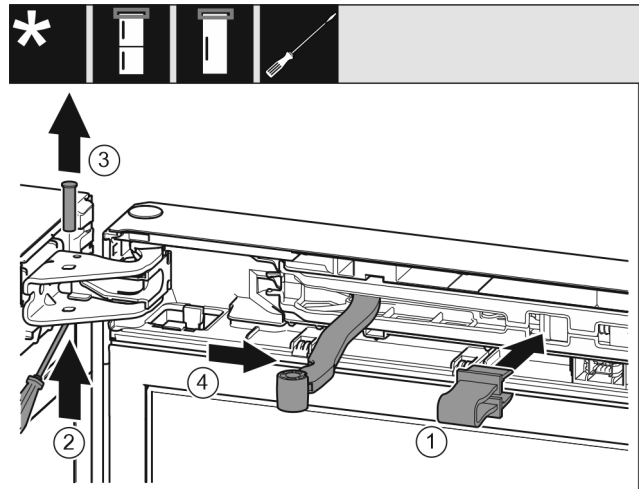

Fig. 8



CAUTION

Crushing hazard from the folding bracket!

▶ Engage the locking device.

- ▶ Snap the locking device Fig. 8 (1) into the opening.
- ▶ Pull out the pin Fig. 8 (2).
- ▶ Pull out the pin Fig. 8 (3) upward.
- ▶ Turn the joint Fig. 8 (4) towards the door.

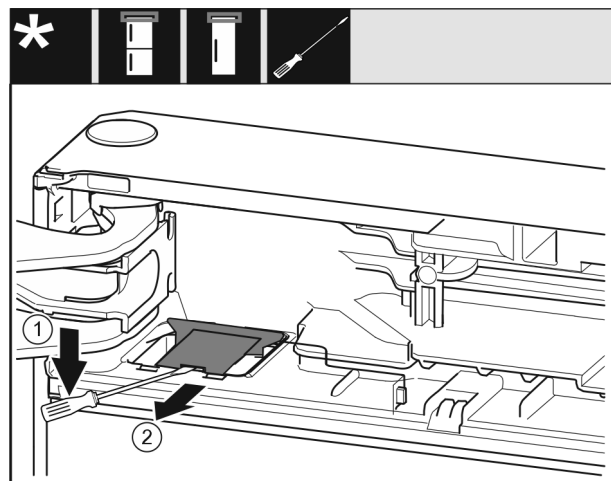

Fig. 9
▶ Use a screwdriver to snap out the cover Fig. 9 (1).
▶ Pull out the cover Fig. 9 (2).

Reversing the door

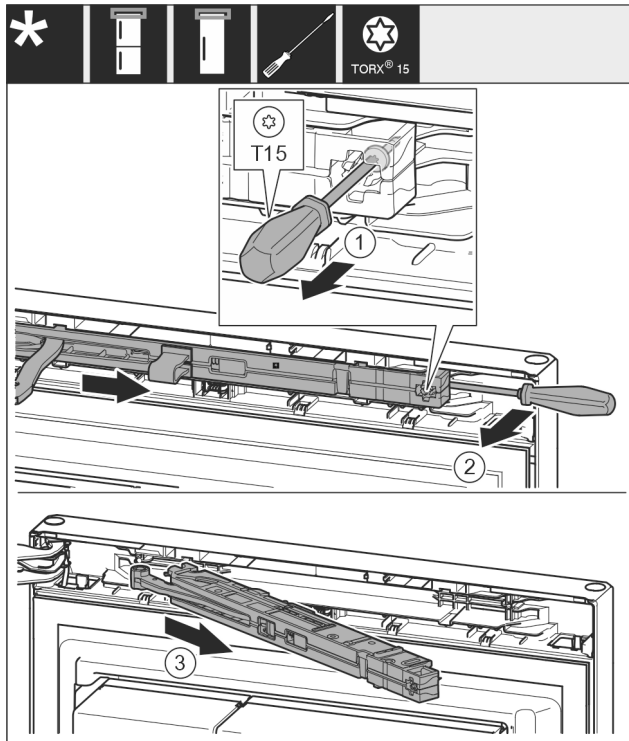

Fig. 10

- ▶ Loosen the screw Fig. 10 (1) on the closing damper unit with a 14 mm (9/16 in) screwdriver.
- ▶ Use the screwdriver to lift out the closing damper unit Fig. 10 (2) on the handle side.
- ▶ Pull out the closing damper unit Fig. 10 (3).

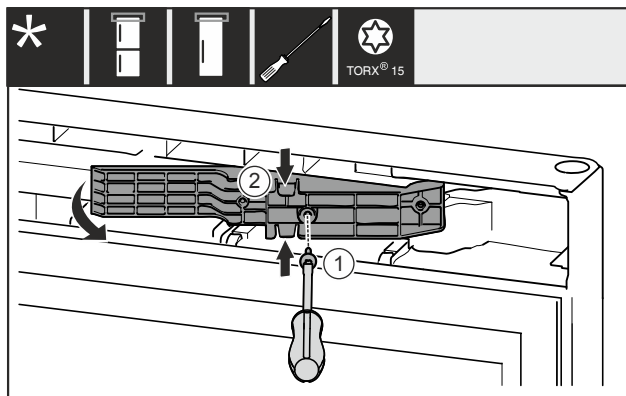

Fig. 11 *

- ▶ Remove the screw Fig. 11 (1).*
- ▶ Gently press the top and bottom of the adapter piece Fig. 11 (2) together and pull it out.*

14.2 Removing the bottom soft stop damper*

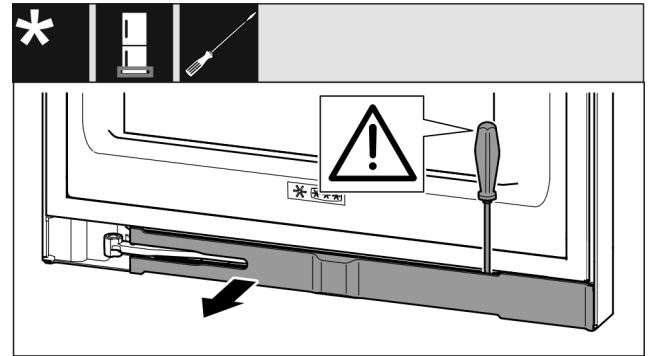

Fig. 12

- ▶ Open the bottom door.

NOTICE

Risk of damage!

If the door seal is damaged the door may not close properly and the level of cooling is insufficient.

- ▶ Do not damage the door seal with the screwdriver!
- ▶ Use a slotted screwdriver to snap out the faceplate and swivel it to the side. (see Fig. 12)

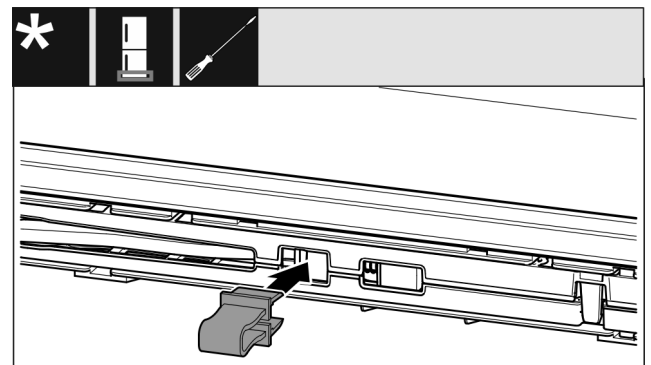

Fig. 13



CAUTION

Crushing hazard from the folding bracket!

- ▶ Engage the locking device.
- ▶ Snap the locking device into the opening. (see Fig. 13)

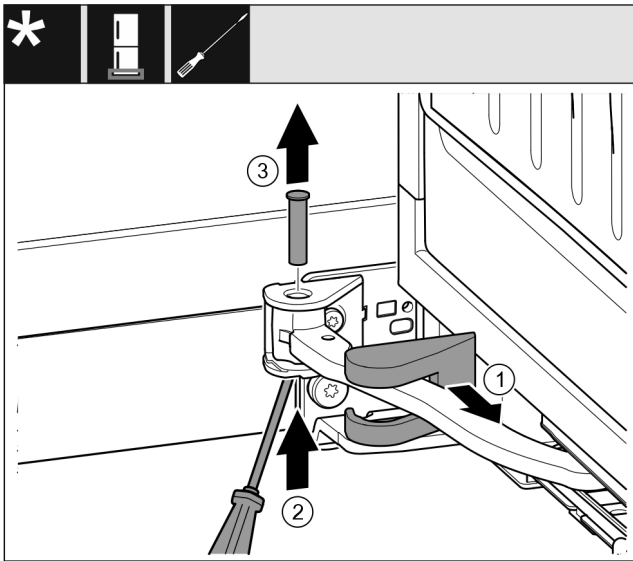

Fig. 14

- ▶ Pull off the swap bearing block cover Fig. 14 (1) and slide it along the joint.
- ▶ Use the screwdriver to lift the pin Fig. 14 (2) from the bottom.
- ▶ Pull the pin Fig. 14 (3) out from the top.

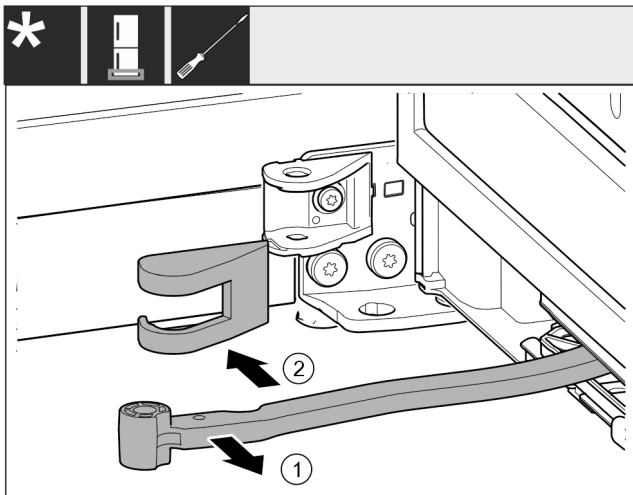

Fig. 15

- ▶ Turn the joint Fig. 15 (1) towards the door.
- ▶ Remove the swap bearing block cover Fig. 15 (2).

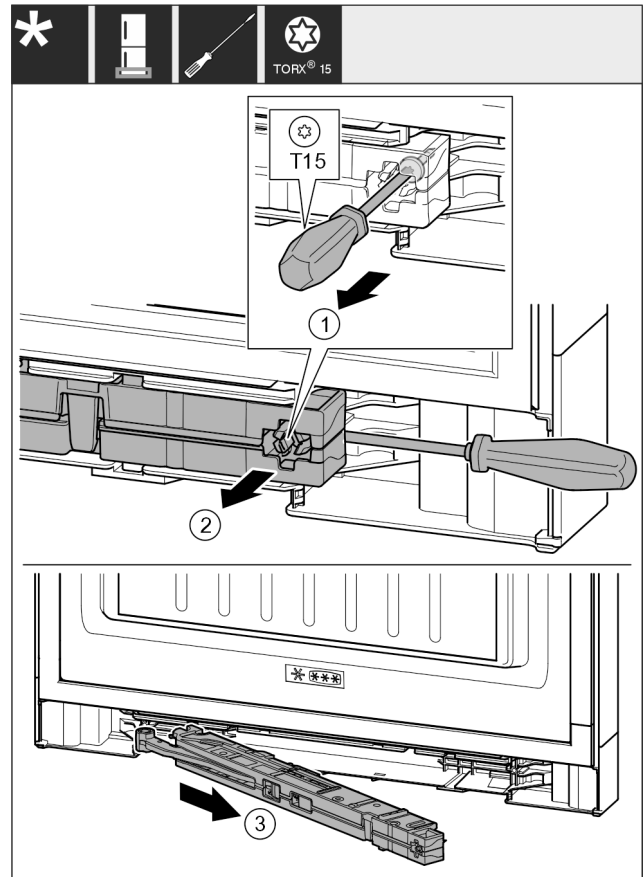

Fig. 16

- ▶ Loosen the screw Fig. 16 (1) on the closing damper unit with a 14 mm (9/16 in) screwdriver.
- ▶ Use the screwdriver to lift out the closing damper unit Fig. 16 (2) on the handle side.
- ▶ Pull out the closing damper unit Fig. 16 (3).
- ▶ Place the soft stop mechanism to one side.

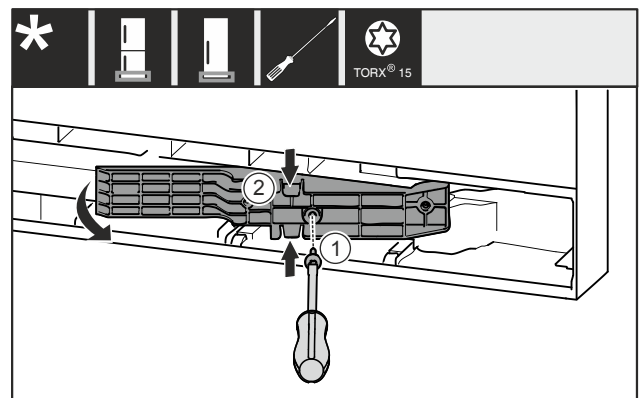

Fig. 17*

- ▶ Remove the screw Fig. 17 (1)*
- ▶ Gently press the top and bottom of the adapter piece Fig. 17 (2) together and pull it out.*

Reversing the door

14.3 Disconnecting the cable connection

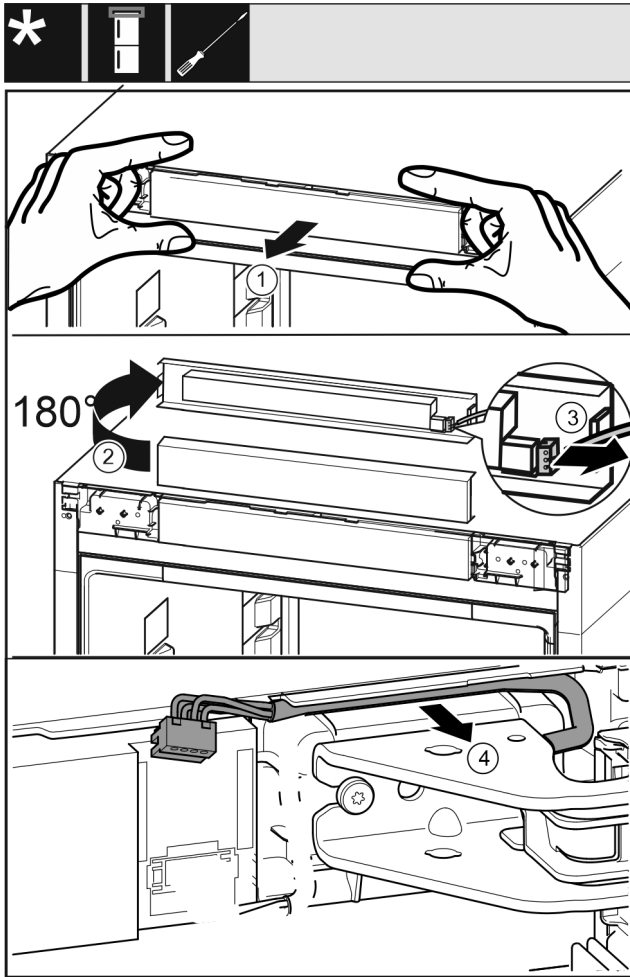

Fig. 18

- ▶ Carefully loosen the control plate Fig. 18 (1) toward the front.
- ▶ Turn the control plate Fig. 18 (2) upward by 180°.
- ▶ Press the latching tab Fig. 18 (3) backwards and carefully pull out the plug.
- ▶ Carefully loosen the cable Fig. 18 (4) above the swap bearing block from the guide.

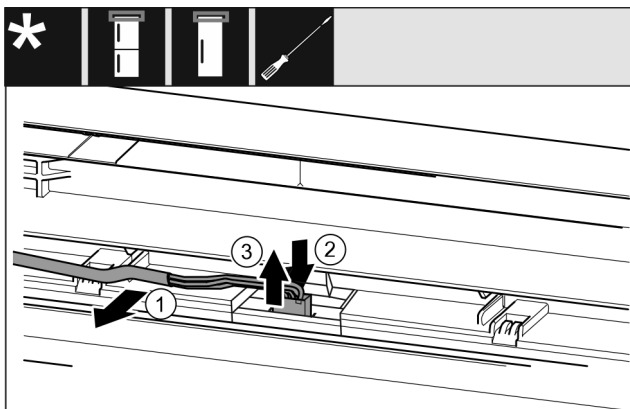

Fig. 19 Fridge/freezer combinations/freezers/cooling units

- ▶ Carefully loosen the cable Fig. 19 (1) from the guide in the door.
- ▶ Press back the tab Fig. 19 (2) behind the plug.
- ▶ Pull the plug Fig. 19 (3) upward carefully.

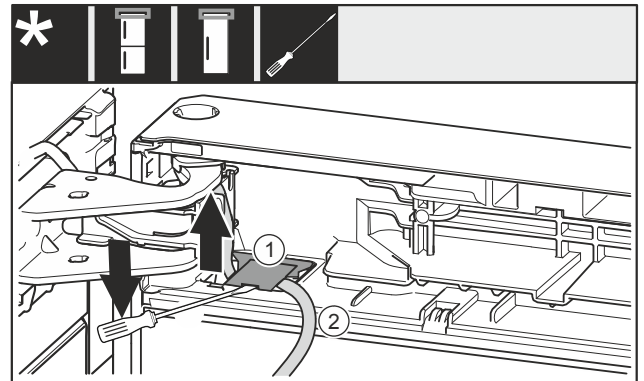

Fig. 20

- ▶ Use the screwdriver to lift up the cover Fig. 20 (1) and pull it out.
- ▶ Pull out the cable Fig. 20 (2).

14.4 Removing the top door

Note

- ▶ To prevent food items from falling out, take all food out of the door racks before removing the door.

For all appliances:

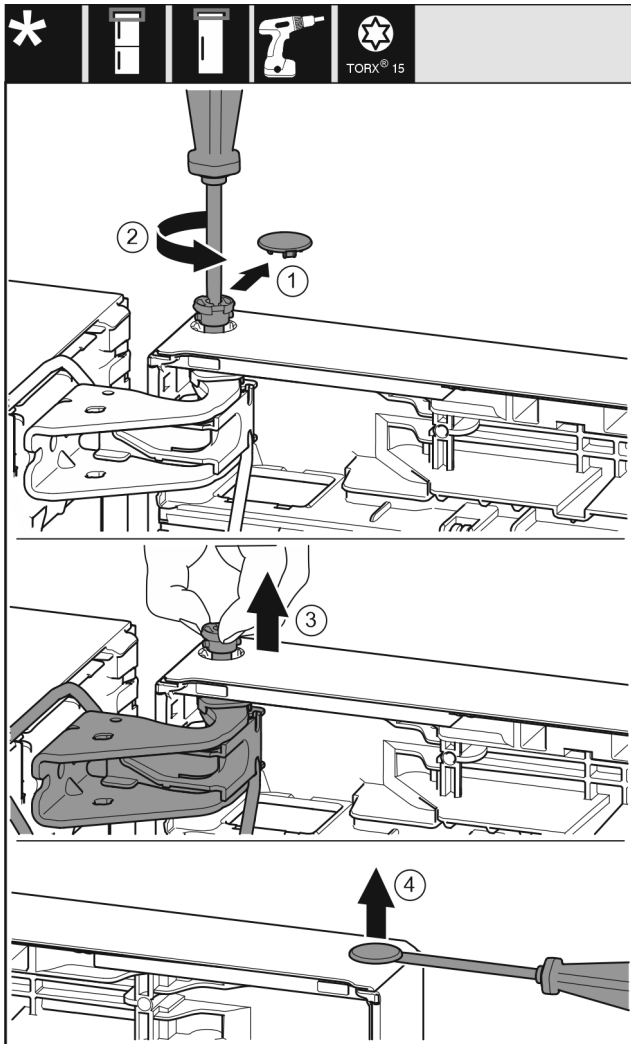

Fig. 21



CAUTION

Risk of injury if the door tips out!

- ▶ Keep a steady grip on the door.
 - ▶ Set the door down carefully.
-
- ▶ Lift the door and place it to one side.

14.5 Removing the bottom door

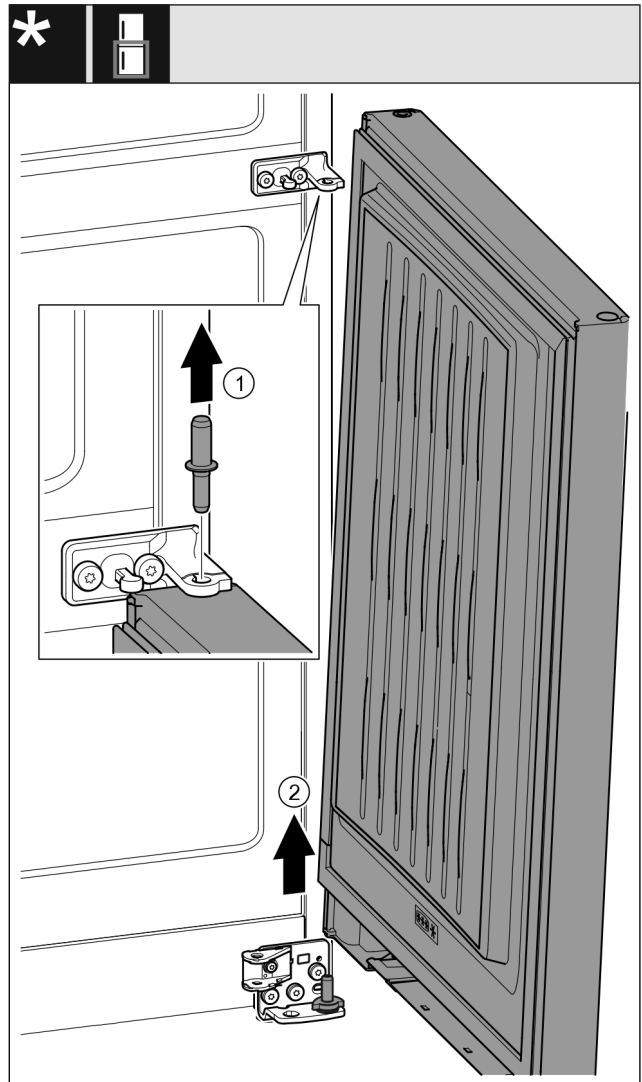

Fig. 22 *



CAUTION

Risk of injury if the door tips out!

- ▶ Keep a steady grip on the door.
 - ▶ Set the door down carefully.
-
- ▶ Pull out the pin Fig. 22 (1) upward.*
 - ▶ Swivel out the door Fig. 22 (2), pull it upward, and set it aside.*

14.6 Moving the upper bearing parts to the other side

For all appliances:

Reversing the door



WARNING

Danger of injury due to door falling out!

If the bearing parts are not screwed on tightly enough, the door may fall out. This can result in serious injuries. In addition, the door may not close causing the appliance to cool improperly.

- ▶ Screw on the bearing brackets/bearing pins tightly with 4 Nm (3 ft lb).
- ▶ Check all screws and retighten them if necessary.

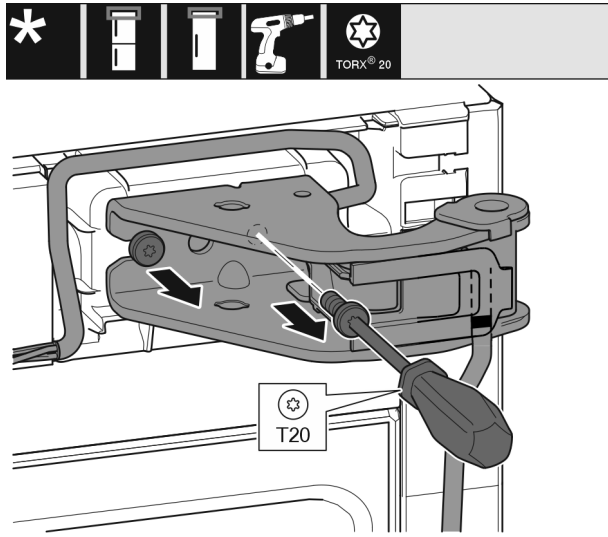

Fig. 23

- ▶ Pull out both screws with the screwdriver.
- ▶ Lift and remove the bearing bracket.
- ▶ Lift and remove the bearing bracket and cable.

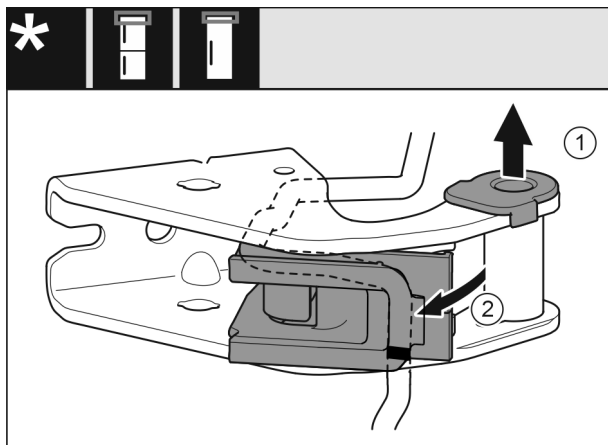

Fig. 24

- ▶ Pull out the bearing bushing Fig. 24 (1) from the guide.
- ▶ Swing out the cable bracket Fig. 24 (2).

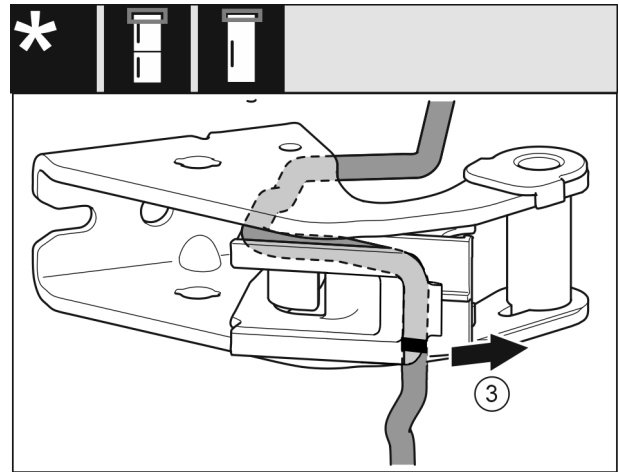

Fig. 25

- ▶ Remove the cable with the cable bracket Fig. 25 (3) from the swap bearing block.

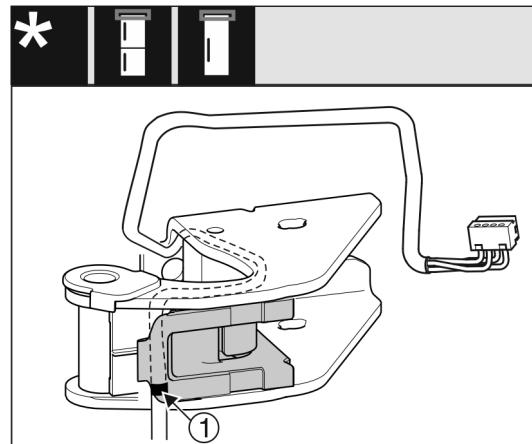

Fig. 26

- ▶ Insert the cable mirror-inverted in the upper groove of the cable holder.
- ▶ The center mark Fig. 26 (1) must be positioned on the edge of the cable bracket.
- ▶ Swing the cable holder in.

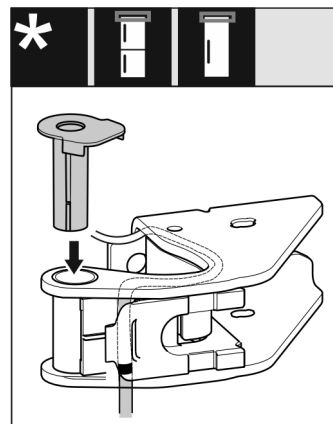

Fig. 27

- ▶ Insert from the other side and latch into place.

NOTICE

Danger of crushing the cable

- ▶ Pay attention to the markings when routing the cable. The cable end with the double marking must be routed into the door end piece.

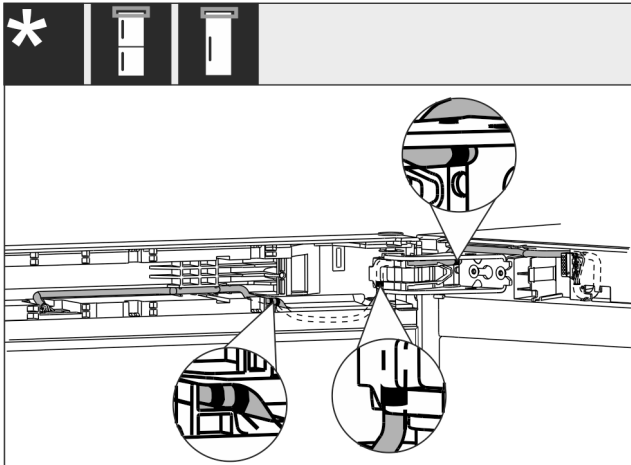

Fig. 28

After making the change, the cable routing must look as shown in the illustration.

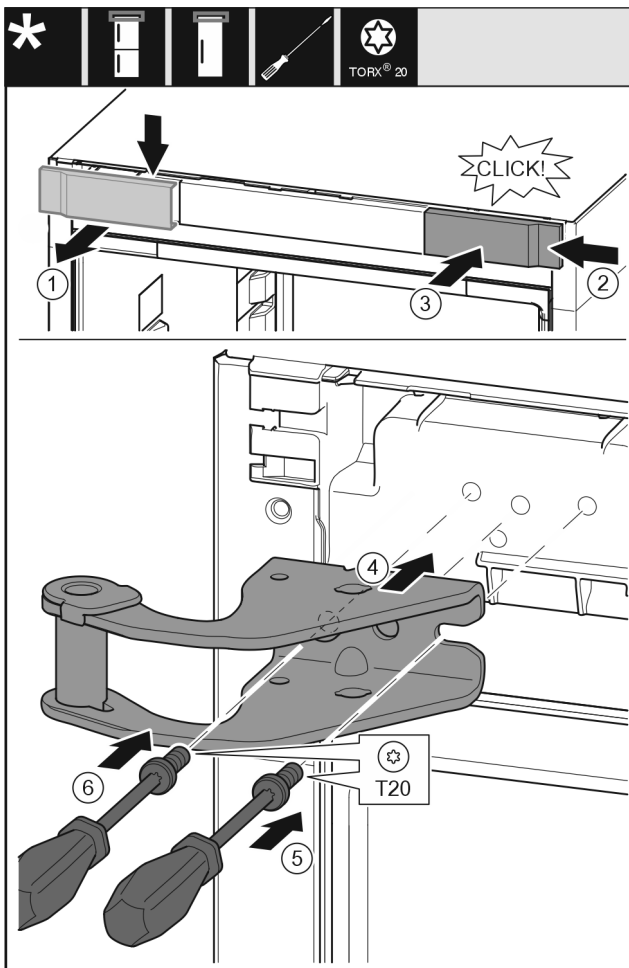

Fig. 29

- ▶ Remove the cover Fig. 29 (1) from the top towards the front.
- ▶ Hang the cover Fig. 29 (2) from the right turned by 180° to the other side.
- ▶ Snap in the cover Fig. 29 (3).
- ▶ Attach the top swap bearing block Fig. 29 (4).
- ▶ Attach and tighten the screw Fig. 29 (5) with a screwdriver.
- ▶ Attach and tighten the screw Fig. 29 (6) with a screwdriver.

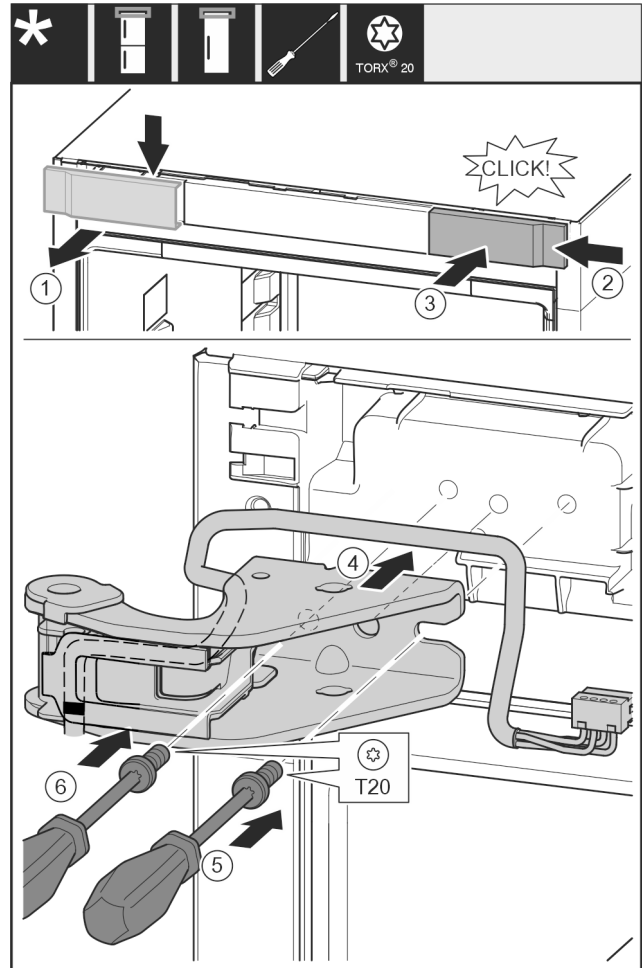

Fig. 30

- ▶ Remove the cover Fig. 30 (1) from the top towards the front.
- ▶ Hang the cover Fig. 30 (2) from the right turned by 180° to the other side.
- ▶ Snap in the cover Fig. 30 (3).
- ▶ Attach the top swap bearing block Fig. 30 (4).
- ▶ Attach and tighten the screw Fig. 30 (5) with a screwdriver.
- ▶ Attach and tighten the screw Fig. 30 (6) with a screwdriver.

Reversing the door

14.7 Moving the central bearing parts to the other side



WARNING

Danger of injury due to door falling out!
If the bearing parts are not screwed on tightly enough, the door may fall out. This can result in serious injuries. In addition, the door may not close causing the appliance to cool improperly.

- ▶ Screw on the bearing brackets/bearing pins tightly with 4 Nm (3 ft lb).
- ▶ Check all screws and retighten them if necessary.

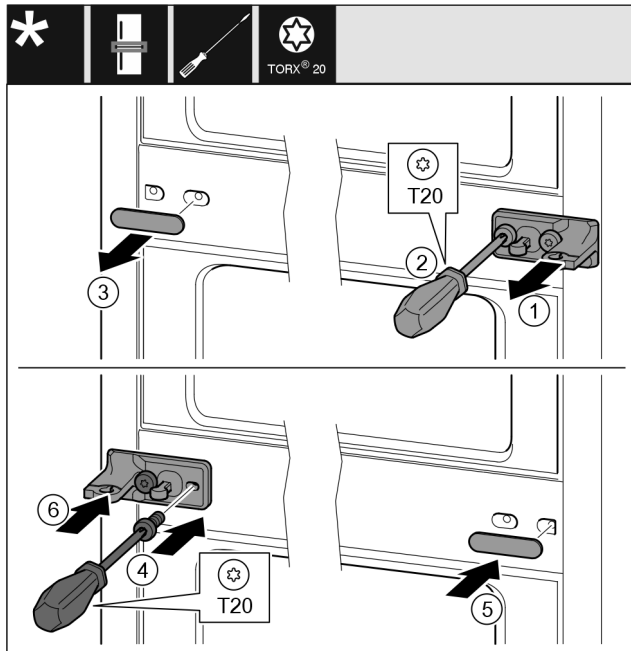

Fig. 31

- ▶ Pull off the washer Fig. 31 (1).
- ▶ Turn out the screws Fig. 31 (2) with the screw driver.
- ▶ Carefully pull off the cover Fig. 31 (3).
- ▶ Tightly screw on the swap bearing block with film Fig. 31 (4) on the other side turned by 180°.
- ▶ Attach the cover Fig. 31 (5) on the other side turned by 180°.
- ▶ Press on the washer Fig. 31 (6) from the front.

14.8 Moving the lower bearing parts to the other side

For all appliances:



WARNING

Danger of injury due to door falling out!

If the bearing parts are not screwed on tightly enough, the door may fall out. This can result in serious injuries. In addition, the door may not close causing the appliance to cool improperly.

- ▶ Screw on the bearing brackets/bearing pins tightly with 4 Nm (3 ft lb).
- ▶ Check all screws and retighten them if necessary.

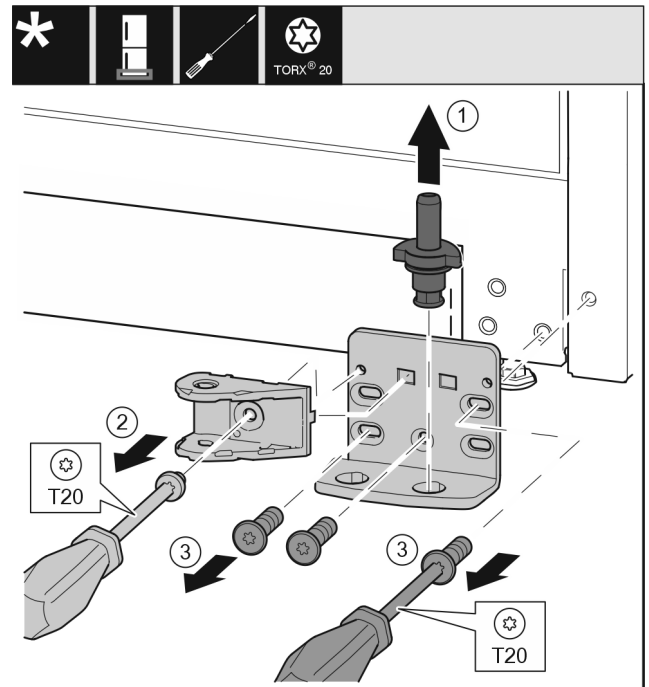

Fig. 32 *

- ▶ Completely pull out the bearing pin Fig. 32 (1) upward.*
- ▶ Use a screwdriver to unscrew the screw Fig. 32 (2) and remove the closing damper connection.
- ▶ Use a screwdriver to unscrew the screws Fig. 32 (3) and remove the swap bearing block.*

For all appliances:

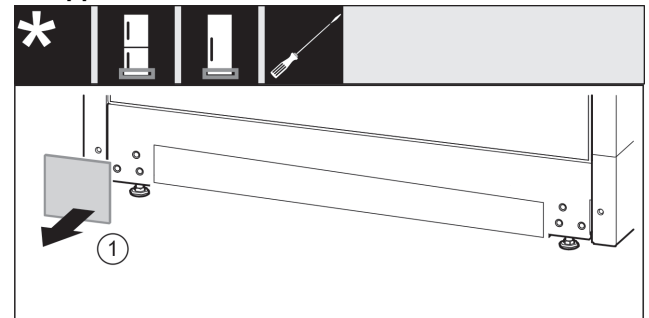

Fig. 33

- ▶ Remove the cover Fig. 33 (1).

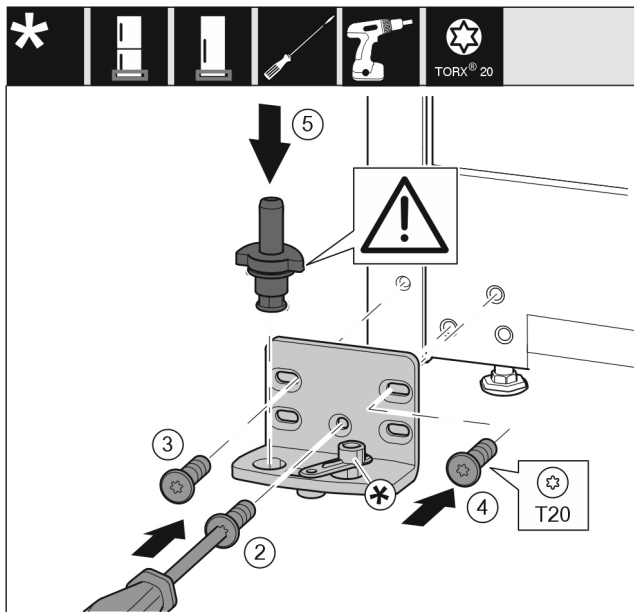

Fig. 34

- ▶ Attach the swap bearing block onto the other side and screw it on using a screwdriver. Start with the screw Fig. 34 (2) at the bottom center.
- ▶ Tighten screw Fig. 34 (3) and screw Fig. 34 (4).
- ▶ Insert the bearing pin Fig. 34 (5) completely. In the process, make sure that the latching cam shows towards the rear.
- ▶ Attach the swap bearing block onto the other side and screw it on using a screwdriver. Start with the screw (2) at the bottom center.
- ▶ Tighten screw (3) and screw (4).
- ▶ Turn the closing damper connection (5) by 180°. On the other side of the swap bearing block, screw it on with the screwdriver.
- ▶ Insert the bearing pin (6) completely. In the process, make sure that the latching cam shows towards the rear.

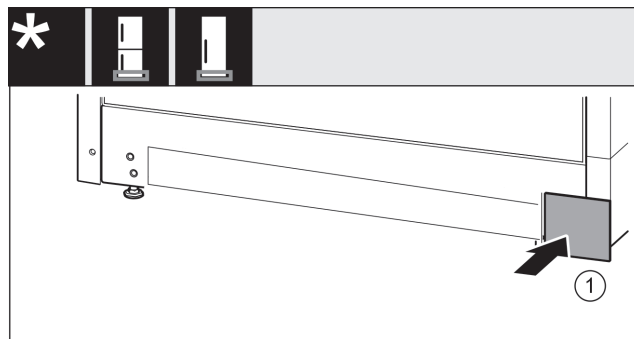

Fig. 35

- ▶ Re-attach the cover Fig. 35 (1) on the other side.

14.9 Moving the door bearing parts to the other side

Top door

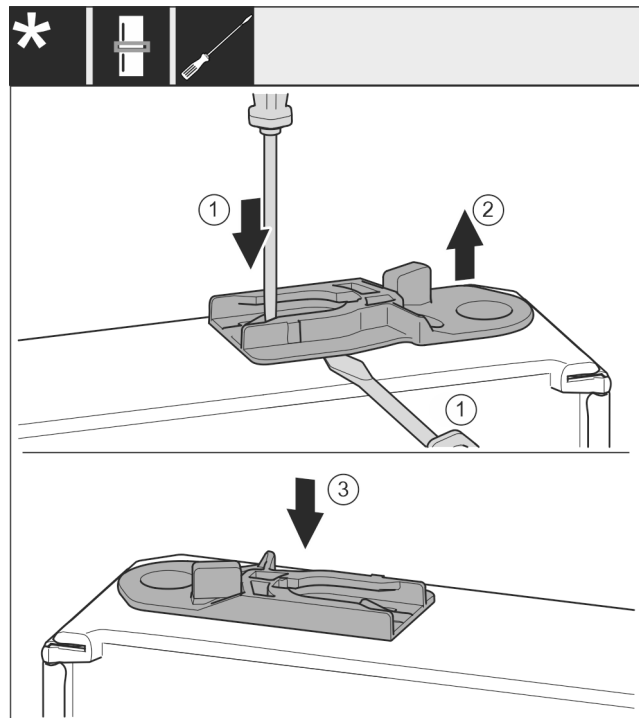

Fig. 36

- ▶ Underside of door faces upwards: Turn the door.
- ▶ Pull out the guide bushing: Press the tab Fig. 36 (1) with the slotted screwdriver while running the slotted screwdriver under the guide bushing Fig. 36 (2) at the same time.
- ▶ Insert the guide bushing Fig. 36 (3) supplied in the scope of delivery on the other side of the housing.
- ▶ Upper side of door faces upwards: Turn the door.

14.10 Moving the handles to the other side

For all appliances:

Reversing the door

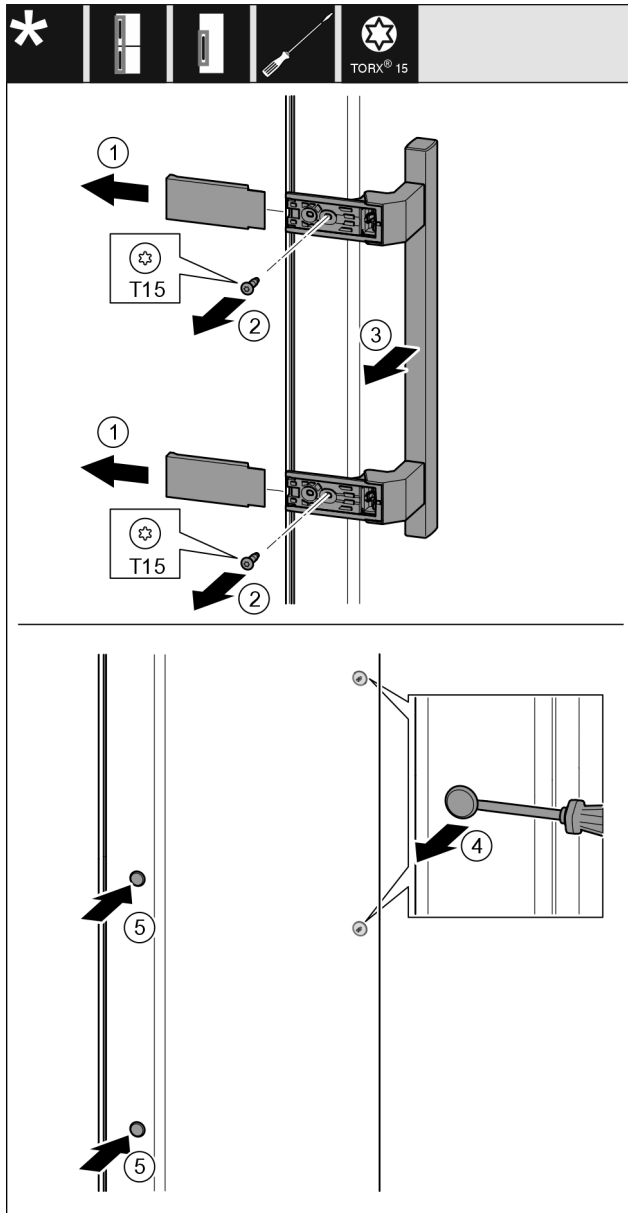

Fig. 37

- ▶ Pull off the cover Fig. 37 (1).
- ▶ Turn out the screws Fig. 37 (2) with the screw driver.
- ▶ Remove the handle Fig. 37 (3).
- ▶ Carefully lift the side plug Fig. 37 (4) with a slotted screwdriver and pull it out.
- ▶ Reinsert the plug Fig. 37 (5) on the other side.

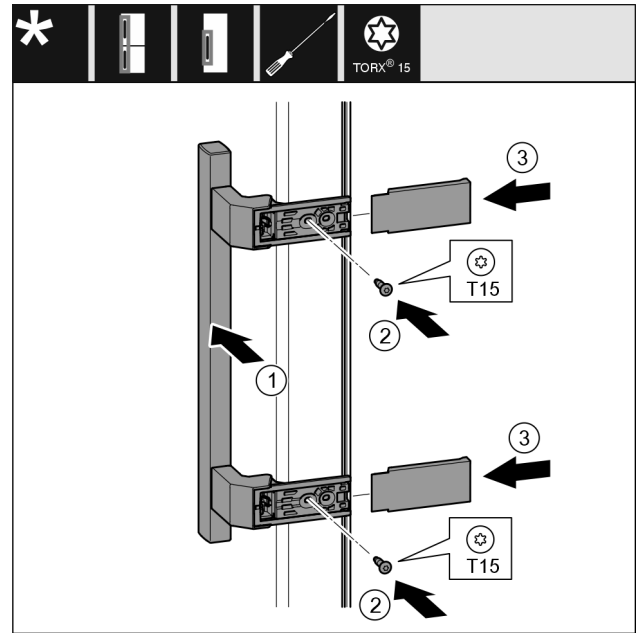

Fig. 38

- ▶ Attach the handle on Fig. 38 (1) the opposite side.
- ▷ The screw holes must be exactly above each other.
- ▶ Tighten the screws Fig. 38 (2) with the screwdriver.
- ▶ Attach the covers Fig. 38 (3) on the sides and slide them on.
- ▷ Ensure that they latch into place correctly.

14.11 Fitting the bottom door

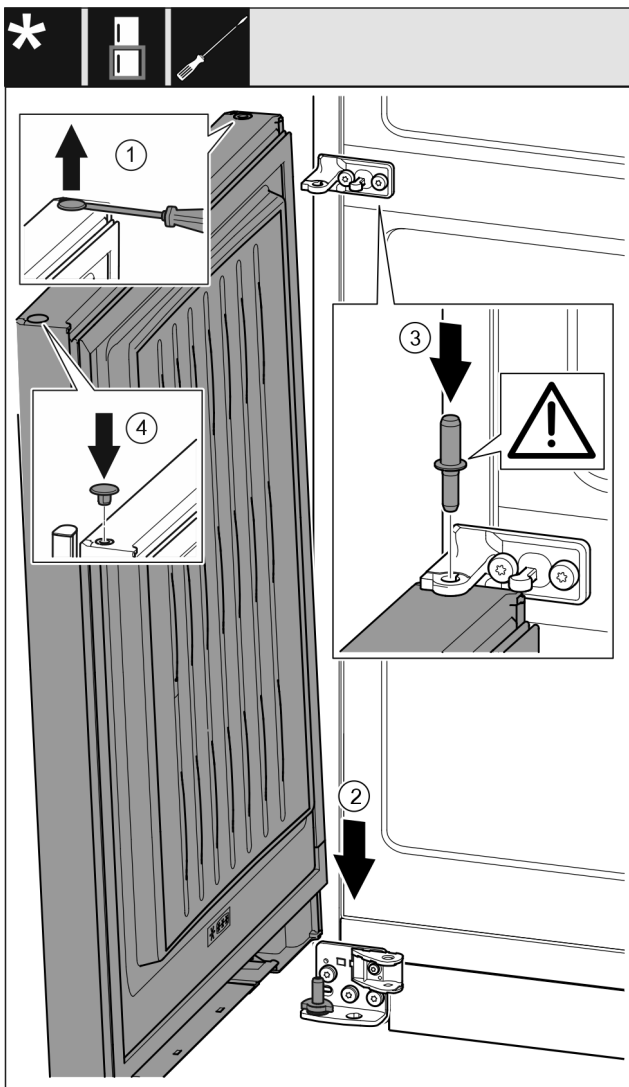

Fig. 39

- ▶ Carefully lift the plug Fig. 39 (1) with a slotted screwdriver and pull it out.
- ▶ Fit the door Fig. 39 (2) onto the lower bearing pin from the top.
- ▶ Insert the center bearing bolt Fig. 39 (3) through the center swap bearing block into the bottom door. In the process, make sure that the latching cam shows towards the rear.
- ▶ Reinsert the plug Fig. 39 (4) on the other side of the door.

14.12 Fitting the top door

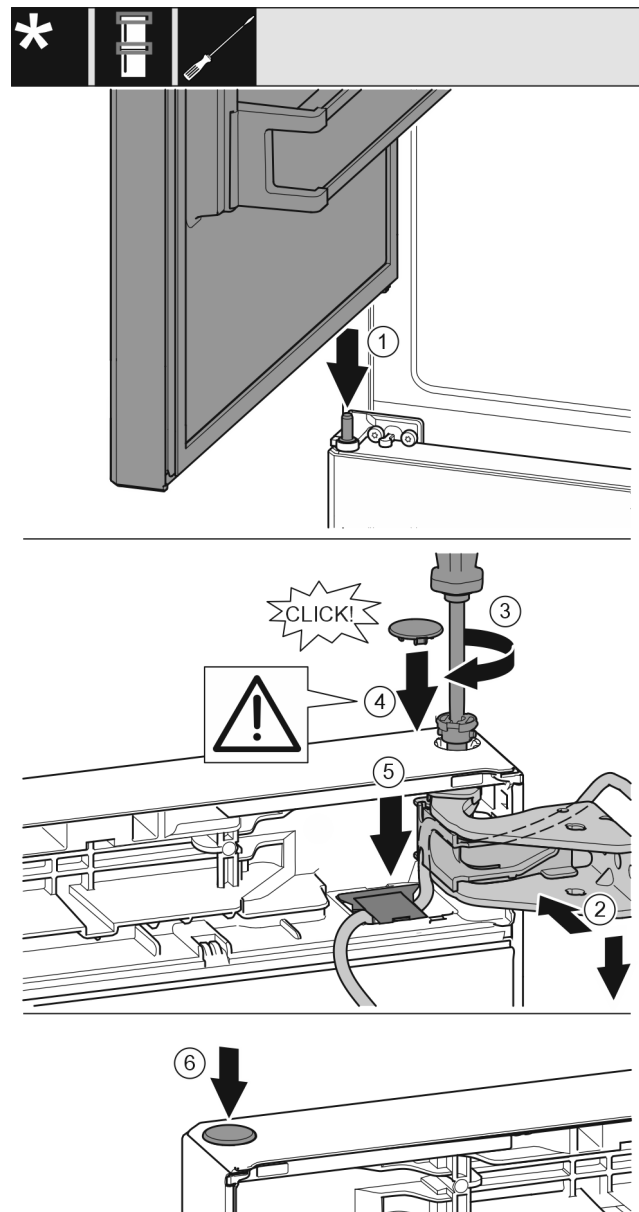

Fig. 40

- ▶ Position to top door onto the center bearing pin Fig. 40 (1).
- ▶ Align the top of the door with opening in the bearing bracket. Fig. 40 (2)
- ▶ Insert the pin Fig. 40 (3) and tighten it with the screwdriver.
- ▶ Mount the safety cover Fig. 40 (4) to protect the door: Insert the safety cover and check whether it is positioned on the door. If so, insert the pin completely.

NOTICE

Cable crushing

- ▶ The marking on the cable must be centered in the holder. The lug with the longer opening must point forwards.

Reversing the door

- ▶ Insert the cover *Fig. 40 (5)* and press it down until it snaps down.
- ▶ Insert the plug *Fig. 40 (6)*.

14.13 Fitting the cable connection

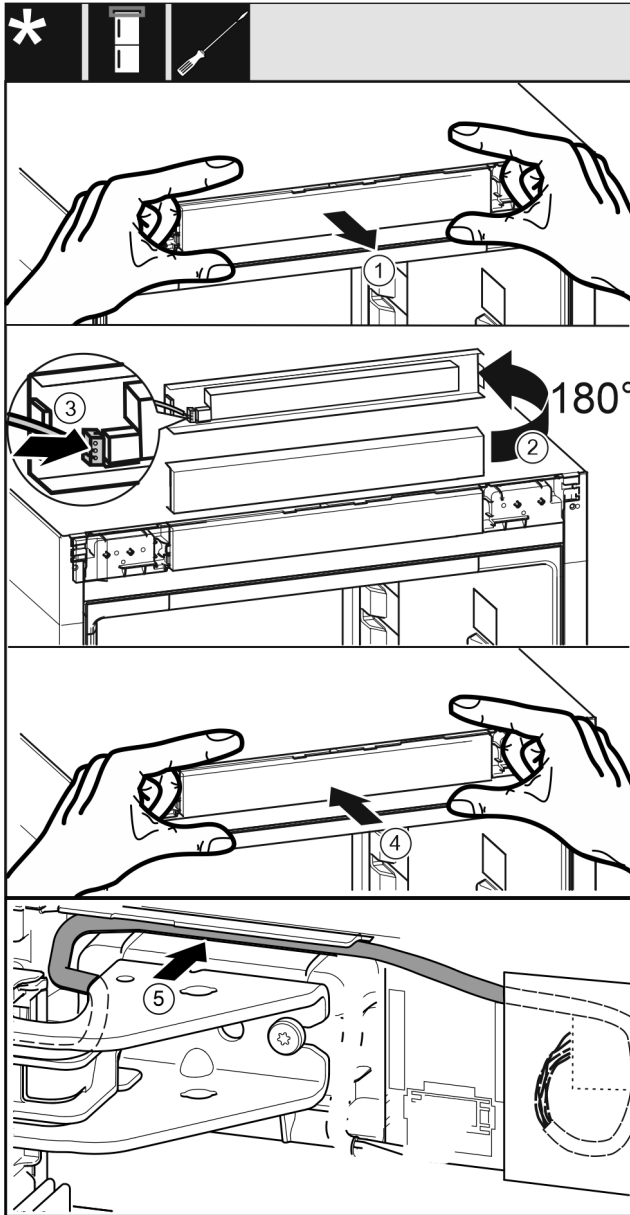

Fig. 41

- ▶ Carefully pull out the control plate *Fig. 41 (1)*.
- ▶ Turn the control plate *Fig. 41 (2)* upward by 180°.
- ▶ Snap the plug *Fig. 41 (3)* into place on the control unit panel.
- ▶ Snap the control plate *Fig. 41 (4)* back onto the appliance.
- ▶ Carefully insert the cable *Fig. 41 (5)* into the guide above the top swap bearing block.

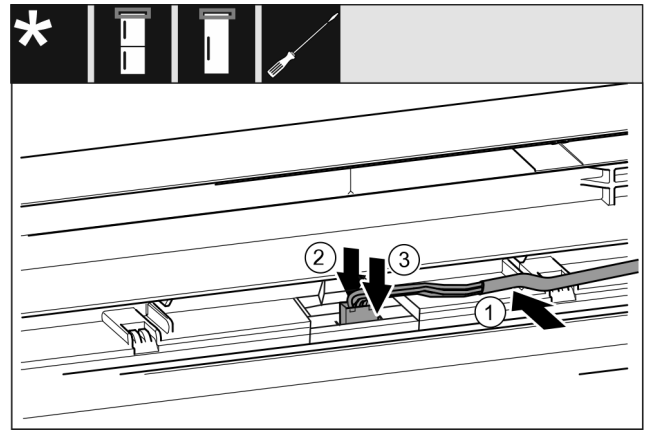

Fig. 42 Fridge/freezer combinations/freezers/cooling units

- ▶ Carefully insert the cable *Fig. 42 (1)* into the guide in the top door.
- ▶ Press the latching tab *Fig. 42 (2)* towards the back.
- ▶ Snap in the plug *Fig. 42 (3)*.
- ▶ Position the remaining cable length as a loop in the guide, if required.

14.14 Aligning the doors

For all appliances:



WARNING

Danger of injury due to door falling out!
If the bearing parts are not screwed on tightly enough, the door may fall out. This can result in serious injuries. In addition, the door may not close causing the appliance to cool improperly.

- ▶ Screw the bearing brackets on firmly with 4 Nm (3 ft lb).
- ▶ Check all screws and retighten them if necessary.
- ▶ Align the doors flush with the appliance housing using the two slots in the lower bearing bracket and center bearing bracket if needed. To do this undo the middle screw in the bottom bearing bracket with the T20 tool supplied. Undo the remaining screws a little with the T20 tool or with a T20 screwdriver and align via the slots. Undo the screws in the middle bearing bracket with the T20 tool and align the middle bearing bracket via the slots.
- ▶ Prop up the door: Screw out the adjustable foot on the bearing bracket using the open-ended wrench SW10 until it comes into contact with the floor, then turn an additional 90°.

14.15 Fit the bottom soft stop mechanism

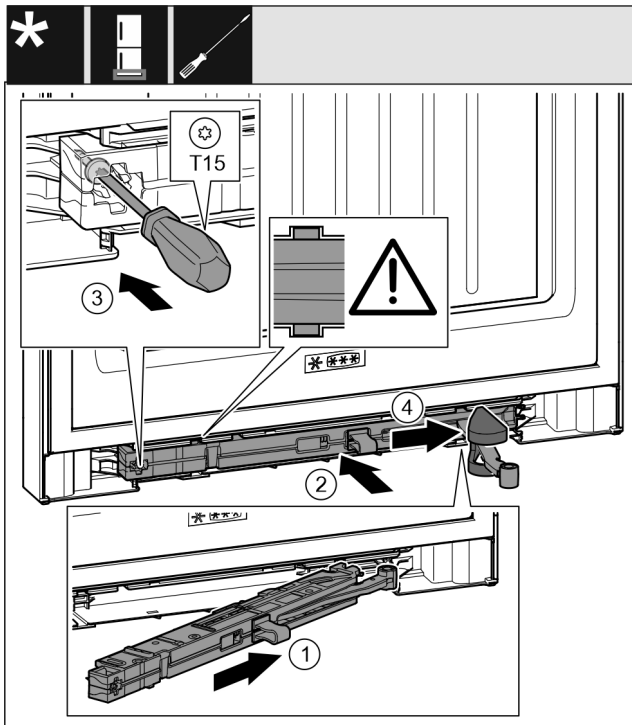

Fig. 43

- ▶ Slide the closing damper unit Fig. 43 (1) on the swap bearing block side up to the stop diagonally into the recess.
- ▶ Push the closing damper unit Fig. 43 (2) completely into the recess.
- ▷ The closing damper unit is positioned correctly if the ridge of the closing damper unit is in the guide.
- ▶ Tighten the screw Fig. 43 (3) with a screwdriver.
- ▶ Push the cover Fig. 43 (4) over the joint.

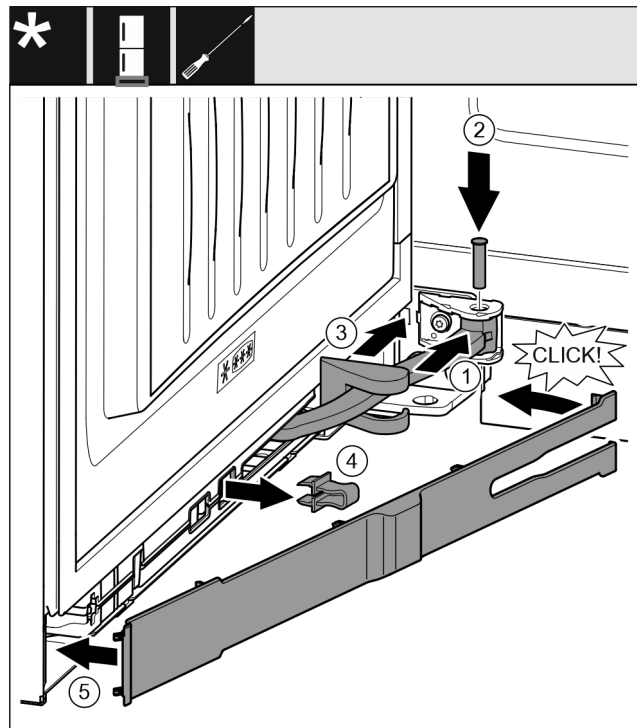

Fig. 44

- ▶ The door is open 90°.
- ▶ Turn the joint Fig. 44 (1) in the hinged suspension.
- ▶ Use a screwdriver to insert the pin Fig. 44 (2) into the hinged suspension and joint. In the process, make sure that the latching cam is correctly positioned in the groove.
- ▶ Slide the swap bearing block cover Fig. 44 (3) along the joint and install it above the hinged suspension.
- ▶ Remove the locking device Fig. 44 (4).
- ▶ Attach the panel Fig. 44 (5) from the handle side and swivel it on.
- ▷ The panel is clicked into place.
- ▶ Close the bottom door.

14.16 Fitting the top soft stop mechanism

For appliances with soft stop mechanism:

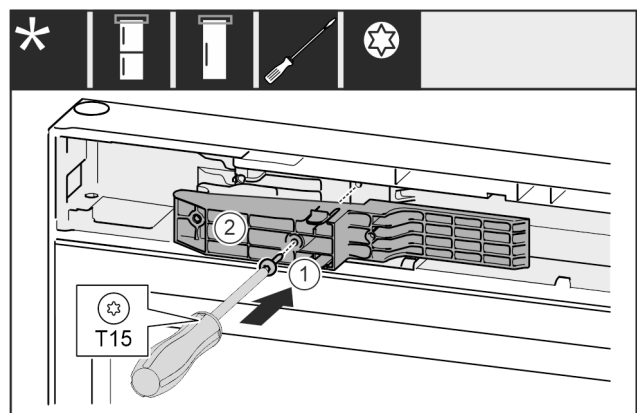

Fig. 45 *

Connecting the appliance to the water supply

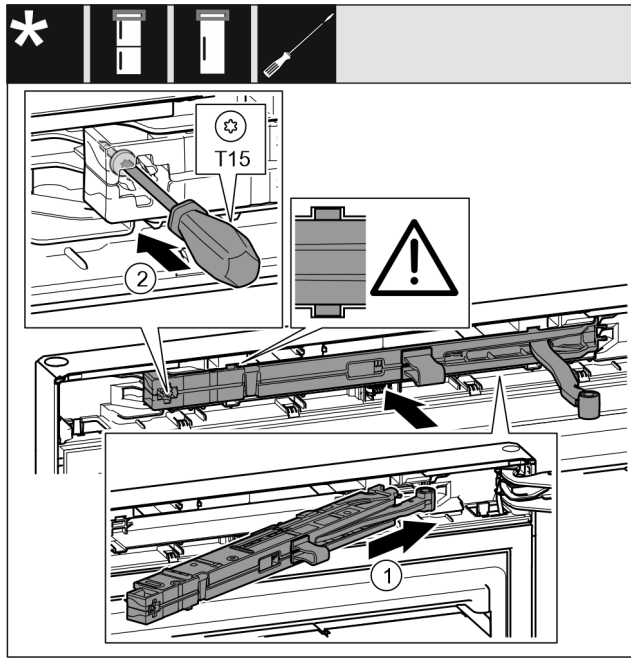

Fig. 46

- ▶ Slide the closing damper unit Fig. 46 (1) on the swap bearing block side up to the stop diagonally into the recess.
- ▶ Slide in the closing damper unit completely.
- ▷ The closing damper unit is positioned correctly if the ridge of the closing damper unit is in the guide in the housing.
- ▶ Tighten the screw Fig. 46 (2) with a screwdriver.

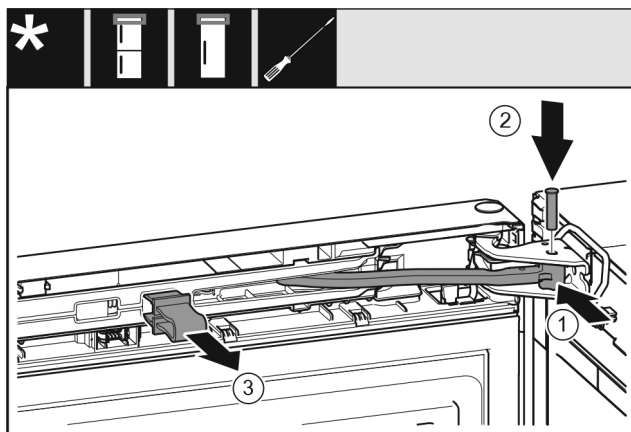

Fig. 47

The door is open 90°.

- ▶ Turn the joint Fig. 47 (1) in the swap bearing block.
- ▶ Insert the pin Fig. 47 (2) into the swap bearing block and joint. In the process, make sure that the latching cam is correctly positioned in the groove.
- ▶ Remove the locking device Fig. 47 (3).

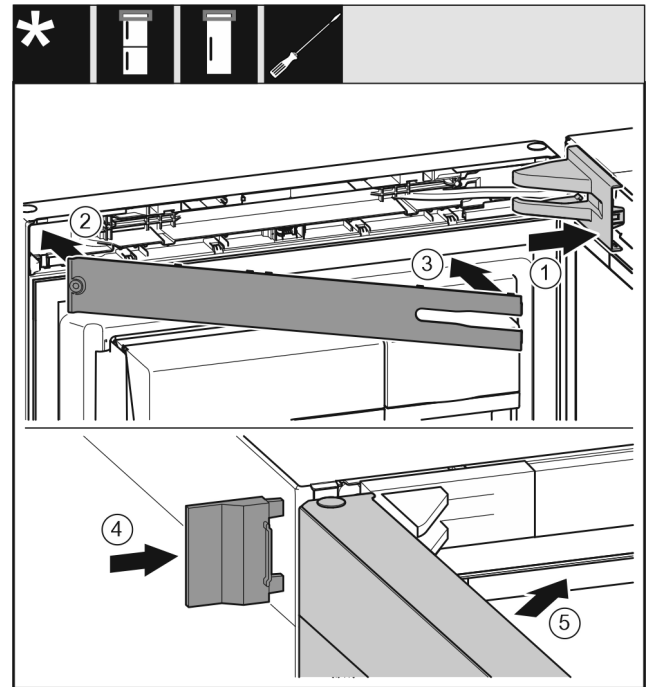

Fig. 48

- ▶ Position the swap bearing block cover Fig. 48 (1) and snap it in. You may need to push it carefully apart.
- ▶ Attach the cover Fig. 48 (2).
- ▶ Cover Fig. 48 (3)
- ▶ Slide on the outer cover Fig. 48 (4).
- ▶ Close the top door Fig. 48 (5).

15 Connecting the appliance to the water supply

Make sure that the following requirements are fulfilled:

- The dimensions for the water supply connection are known and complied with.
- The correct water pressure is maintained.
- Water is supplied to the appliance via a cold water pipe that can withstand the operating pressure and is connected to the drinking water supply.
- All equipment and devices used for the water supply comply with the applicable regulations in the country of use.
- The back of the appliance is accessible so that you can connect the appliance to the drinking water supply.
- A coupler between the R3/4 connection thread and the 1/4" OD copper pipe is supplied.*
- There is a screen filter with a seal in the coupler. The screen filter with a seal is supplied.*
- A **1/4" OD copper pipe** is used to connect the water supply to the solenoid valve. **This is not supplied with the appliance.***

Connecting the appliance to the water supply

- ❑ There is an adaptor between the hose 1/4" OD copper pipe and the domestic water connection so that you can turn off the water supply if necessary.*
- ❑ The adaptor is not directly behind the appliance and is easily accessible. This way, you can push the appliance as close as possible to the wall and can quickly turn off the faucet if necessary.*

WARNING

Risk of electric shock from water!

- ▶ Before connecting to the water hose: Disconnect the appliance from the mains.
- ▶ Before connecting to water lines: Shut off the water supply.
- ▶ Make sure that only qualified personnel connect the device to the drinking water supply.

WARNING

Risk of poisoning due to contaminated water!

- ▶ Connect to potable water supply only.

15.1 Connecting the water pipe*

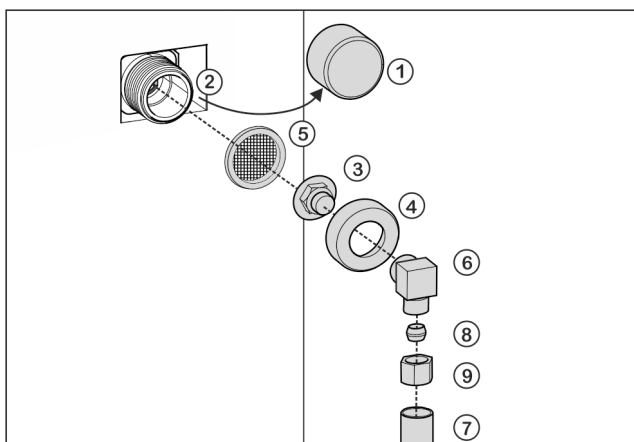

Fig. 49

- | | |
|--------------------|--|
| (1) Cap | (6) Angle piece |
| (2) Solenoid valve | (7) Water pipe (e. g. 1/4" OD copper pipe) |
| (3) Coupler | (8) Clamp ring |
| (4) Union nut | (9) Nut |
| (5) Screen filter | |

NOTICE

Risk of damage from incorrect installation!

- ▶ Do not damage or kink the water pipe (e. g. copper pipe) during installation.
- ▶ Do not damage or kink the water pipe (e. g. copper pipe) when setting up the appliance.

Connecting the coupler to the appliance:

- ▶ Remove cap Fig. 49 (1) from solenoid valve Fig. 49 (2).
- ▶ Insert coupler Fig. 49 (3) into union nut Fig. 49 (4).

NOTICE

The filter can be damaged if not correctly fitted!

- ▶ Observe the following instruction when putting in the filter.
- ▶ Insert the filter Fig. 49 (5) with the recess pointing down towards the coupler Fig. 49 (3).

NOTICE

The thread can be damaged if the union nut is over-tightened!

- ▶ Observe the following instructions for fitting the union nut on the solenoid valve.
- ▶ Screw the union nut Fig. 49 (4) by hand onto the thread of the solenoid valve Fig. 49 (2) until it is firmly in place.
- ▷ The coupler is connected to the appliance.

90° bend in the water connection: Connecting the water hose to the elbow connector:

- ▶ Screw on angle piece Fig. 49 (6).
- ▶ Connect the water pipe Fig. 49 (7) (e. g. 1/4" OD copper pipe) with the clamp ring Fig. 49 (8) and nut Fig. 49 (9) to the elbow connector Fig. 49 (6).
- ▷ The water pipe is connected to the elbow connector.

-or-

No bend in the water connection: Connecting the water hose to the coupler:

- ▶ If necessary: Fasten the water pipe Fig. 49 (7) to the housing with the guide clip.
- ▶ Put angle piece Fig. 49 (6) to one side.
- ▶ Connect the water pipe Fig. 49 (7) (e. g. 1/4" OD copper pipe) with the clamp ring Fig. 49 (8) and nut Fig. 49 (9) to the coupler Fig. 49 (3).
- ▶ If necessary: Fasten the water pipe Fig. 49 (7) to the housing with the guide clip.
- ▷ The water pipe is connected to the coupler.

Fitting the adaptor between the water pipe and the water supply:

- ▶ Connect the water pipe (e. g. 1/4" OD copper pipe) to the water supply with a suitable adaptor.
- ▷ The water is connected to the water supply with an adaptor.

15.2 Check the water system

Before you completely install the appliance, Liebherr recommends checking the water system for leaks.

- ▶ Slowly turn on the water feed.*
- ▶ Check the hose, water feed and connections for leaks.
- ▷ The water system has now been checked for leaks.
- ▷ The water system is not leaking: You can install up the appliance completely.

Note

IceMaker: Before the first use, you must clean the IceMaker. (see Quick Start Guide or operating instructions)

Connecting the appliance to the power supply

16 Connecting the appliance to the power supply



WARNING

Danger of electric shock and injury due to damaged appliance or damaged mains cable!

Cuts and fatal injury. If the appliance or the mains cable is damaged during transport, you may be electrocuted. You could also cut yourself on damaged parts of the appliance housing.

- ▶ Check the appliance and the mains cable for damage after transport.
- ▶ Never put the appliance into operation if the appliance or the mains cable are damaged.
- ▶ Contact Customer Service.

You can connect your appliance to the mains using the power cable supplied separately. The mains power cable has an appliance coupler at one end and a mains plug at the other end.

Make sure that the following requirements are fulfilled:

- The appliance and power cable are undamaged.
- The appliance is set up in accordance with the regulations. (see 9 Mounting wall spacers)
- Requirements for the electrical connection are met. (see 2 Setup conditions)
- Dimensions for connection in accordance with regulations are known and observed. (see 5 Connection dimensions for the power supply)
- Mains voltage and frequency correspond to the specifications on the type plate.
- The socket is grounded and fused in accordance with regulations.
- The tripping current for the fuse is between 10 A and 16 A.
- Outlet is easily accessible and is not behind the appliance. (see 5 Connection dimensions for the power supply)

NOTICE

Danger of damage to incorrect operation!

Damage to the electrical components of the appliance.

- ▶ Only use the supplied power cable.

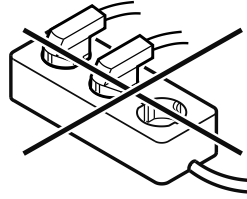

NOTICE

Danger of damage to incorrect connection!
Damage to the appliance.

- ▶ Do not connect the appliance to a stand-alone inverter, e.g. solar power systems and petrol generators.

- ▶ Connect the mains plug of the power cable to the power supply.
 - ▷ The Liebherr logo appears in the display.
 - ▷ The display switches to the standby symbol.
 - ▷ If no action is taken within 60 seconds: Standby symbol fades or disappears.
- ▶ Appliance is connected. For initial commissioning, see the next chapter or the operating instructions.



WARNING

Danger of fire due to incorrect connection!

Burns.

Damage to the appliance.

- ▶ Do not use an extension cord.
- ▶ Do not use a multipoint connector strip.



home.liebherr.com/fridge-manuals

EN Combined fridge-freezer

Issue date: 20241113

Part number index: 7086363-00

For Service in the U.S.: Liebherr Service Center
Toll Free: 1-866-LIEBHER or 1-866-543-2437
Service-appliances.us@liebherr.com
PlusOne Solutions, Inc.
3501 Quadrangle Blvd, Suite 120
Orlando, FL 32817

For Service in Canada: Liebherr Service Center
Toll Free: 1-888-LIEBHER or 1-888-543-2437
www.euro-parts.ca
EURO-PARTS CANADA
39822 Belgrave Road, Belgrave, Ontario, N0G 1E0
Phone: (519) 357-3320 | Fax: (519) 357-1326



Installation Guide

Quality, Design and Innovation



home.liebherr.com/fridge-manuals









LIEBHERR

General safety instructions

Contents

1	General safety instructions.....	2
2	Setup conditions.....	3
2.1	Space.....	3
2.2	Fitting the appliance into the kitchen unit....	3
2.3	Setting up multiple appliances.....	4
2.4	Electrical connection.....	5
3	Installation dimensions.....	5
4	Ventilation requirements.....	6
5	Connection dimensions for the power supply.....	6
6	Water connection.....	6
6.1	Water pressure.....	7
7	Transporting the appliance.....	7
8	Unpacking the appliance.....	7
9	Mounting wall spacers.....	7
10	Setting up the device.....	7
11	Setting up the appliance level.....	8
12	After setup.....	8
13	Disposal of packaging.....	8
14	Reversing the door.....	8
14.1	Taking off the top soft stop mechanism*.....	9
14.2	Removing the bottom soft stop damper*.....	10
14.3	Disconnecting the cable connection.....	12
14.4	Removing the top door.....	12
14.5	Removing the bottom door.....	13
14.6	Moving the upper bearing parts to the other side.....	13
14.7	Moving the central bearing parts to the other side.....	16
14.8	Moving the lower bearing parts to the other side.....	16
14.9	Moving the door bearing parts to the other side.....	17
14.10	Moving the handles to the other side.....	17
14.11	Fitting the bottom door.....	19
14.12	Fitting the top door.....	19
14.13	Fitting the cable connection.....	20
14.14	Aligning the doors.....	20
14.15	Fit the bottom soft stop mechanism.....	21
14.16	Fitting the top soft stop mechanism.....	21
15	Connecting the appliance to the water supply.....	22
15.1	Connecting the water pipe*.....	23
15.2	Check the water system.....	23
16	Connecting the appliance to the power supply.....	24

The manufacturer is constantly working to improve all types and models. Therefore, please be aware that we reserve the right to make changes to the shape, equipment and technology.

Symbol	Explanation
	Read instructions Please read the information in these instructions carefully to understand all of the benefits of your new appliance.
	Additional information online The digital manual with supplemental information can be found online by scanning the QR code on the front page of this manual or by entering the service number at home.liebherr.com/fridge-manuals .
	Check appliance Check all parts for transport damage. If you have any complaints, please contact your agent or customer service.
	Differences These instructions apply to a range of models, so there may be differences. Sections that apply to certain models only are indicated by an asterisk (*).
	Instructions and results Instructions are marked with a ▶. Results are marked with a ▷.
	Videos Videos about the appliances are available on the YouTube channel of Liebherr-Hausgeräte.

Open-source licenses:

The appliance includes software components that make use of open-source licenses. You can find information on the open-source licenses to be used here: home.liebherr.com/open-source-licenses

1 General safety instructions

- Please keep this assembly manual in a safe place so you can refer back to it at any time.
- If you pass the appliance on, please hand this assembly manual to the new owner.
- Read this assembly manual before installation and use in order to use the appliance safely and correctly. Follow the instructions, safety instructions and warning messages included at all times. They are important for ensuring you can operate and install the appliance safely and without any problems.
- First read the general safety instructions in the “General safety instructions” section of the **operating instructions**, which accompany these installation instructions, and

follow them. If you cannot find the **operating instructions**, you can download the **operating instructions** from the internet by entering the service number at home.liebherr.com/fridge-manuals. The service number can be found on the serial

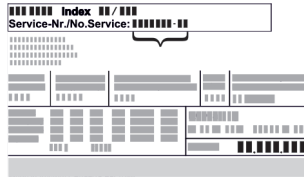

tag:

- **Observe the warning messages and other detailed information in the other sections when installing the appliance:**

	DANGER	indicates a hazardous situation, which if not avoided, will result in death or serious injury.
	WARNING	indicates a hazardous situation, which if not avoided, could result in death or serious injury.
	CAUTION	indicates a hazardous situation, which if not avoided, will result in minor or moderate injury.
	NOTICE	indicates a hazardous situation, which if not avoided, could result in damage to property.
	Note	indicates useful advice and tips.

2 Setup conditions

WARNING

Risk of fire due to moisture!

If live parts or the power cord get wet, this can cause a short circuit.

- The appliance is designed for use in enclosed spaces. Do not operate the appliance in open space or in damp areas or where there is spray.

Normal use

- Only set up and use the appliance in enclosed spaces.

2.1 Space

WARNING

Leaking refrigerant and oil!

Fire. The refrigerant contained within the appliance is environmentally friendly, but flammable. The oil contained within the appliance is flammable. Escaping refrigerant and oil can ignite if they are of high enough concentration and are exposed to an external heat source.

- Do not damage the pipelines of the coolant circuit and the compressor.

- If the appliance is installed in a very damp environment condensate water may form on the outside of the appliance. Always ensure sufficient airflow and ventilation in the setup location.
- The more refrigerant there is in the appliance, the larger the space that it is installed in must be. If the space is too small, any leak may create a flammable mixture of gas and air. For every 8 g (0.28 oz) of refrigerant, the installation space must be at least 1 m³ (35.5 ft³). Specifications on the refrigerant in the appliance can be found on the serial tag plate inside the appliance.

2.1.1 Installation surface

- The floor of the installation site must be horizontal and level.
- The height of the appliance base must be the same as the surrounding floor.

2.1.2 Installation position

- Do not set up the appliance in an area with direct sunlight, next to a heating unit or similar.
- You can set up the appliance directly next to an oven.
- If you set up the appliance directly next to an oven, its energy consumption may increase slightly. This depends on the service life and how often the oven is used.
- Always stand the appliance backed directly to the wall using the enclosed wall spacers (see below).

2.2 Fitting the appliance into the kitchen unit

You can install kitchen cabinets around the appliance.

Setup conditions

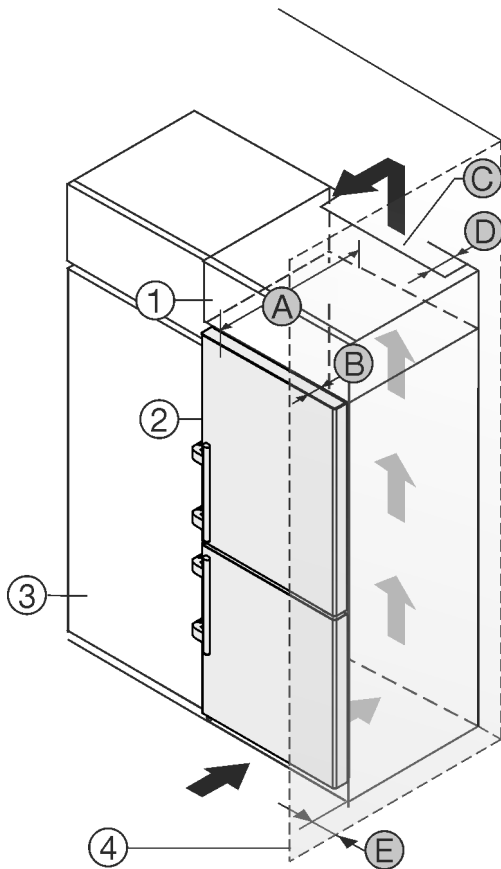

Fig. 1

(1) Top cabinet
(2) Appliance

(3) Kitchen cabinet

(4) Wall

(A) Appliance depth

(B) Door depth

(C) Ventilation cross-section

(D) Distance to the rear of the appliance

(E) Distance to the side of the appliance

You can place the appliance directly beside the kitchen cabinet Fig. 1 (3).

There must be a ventilation shaft at the depth Fig. 1 (D) of the back of the top cupboard over the entire width of the top cupboard.

The cross section of the ventilation gap Fig. 1 (C) must be maintained below the ceiling.

If the appliance is set up with the hinges next to a wall Fig. 1 (4), the distance between the appliance and the wall must be at least 57 mm (2 1/4 in) . This is how far the handle protrudes when the door is open.

In order to be able to fully open the door, the appliance must protrude by the depth of the door Fig. 1 (B) from the front of the kitchen cabinet. Regardless of the depth of the kitchen cabinets Fig. 1 (3) and use of wall spaces, the appliance can protrude further.

Appliances with lever handle:

A	675 mm (26 9/16 in) *
---	-----------------------

Appliances with lever handle:

B	75 mm (2 15/16 in)
C	Min. 300 cm ² (46.5 in ²)
D	mind. 50 mm (1 15/16 in)
E	Min. 57 mm (2 1/4 in)

* The use of wall spacers increases the dimensions by 15 mm (5/8 in) (see 9 Mounting wall spacers) .

Note

A set for restricting the door opening angle to 90° can be acquired from Customer Services for appliances with soft closing.

Ensure that the following conditions are met:

- Recess dimensions are adhered to .
- Ventilation requirements are complied with (see 4 Ventilation requirements) .

2.3 Setting up multiple appliances

The appliances were developed for different installation options. If you want to install several appliances side by side or on top of each other, make sure that the following requirements are met:

- Only install those appliances side by side or on top of each other that were developed for the purpose.
- Observe the instructions and the following table.

NOTICE

Risk of damage caused by water condensate!

- ▶ Do not set up the appliance next to another refrigeration/freezer unit.

Model	Installation type
All models	individually
Models with a model designation that starts with S...	Side-by-side (SBS)

3 Installation dimensions

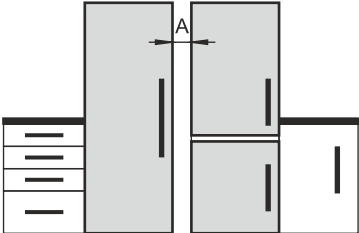
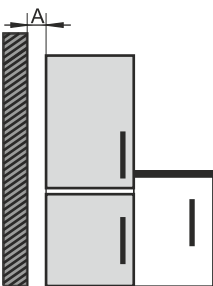
Model	Installation type
Models without side wall heating	 <p>Next to each other: Install with a distance A from 70 mm (2 3/4 in) between the appliances.</p> <p>Next to each other: Install with a distance A from 100 mm (3 15/16 in) between the appliances.</p> <p>If you do not keep this distance, condensate can form on the side walls between the appliances.</p>  <p>At an outside wall: Install with a distance A as for a side-by-side installation.</p> <p>If you do not keep this distance, condensate can form on the side wall of the appliance.</p>

Models and their installation type

Assemble the appliances according to the separate assembly instructions.

2.4 Electrical connection



WARNING

Danger of fire due to incorrect positioning!

If the power supply cable or plug touches the back of the appliance, the vibration can damage the power supply cable or the plug resulting in a short circuit.

- ▶ Make sure the power supply cable is not trapped under the appliance when you position the appliance.
- ▶ Install the appliance so that it does not touch any plugs or power cables.
- ▶ Do not connect any appliances to sockets in the area of the back of the appliance.
- ▶ Do **not** place and operate power strips/power distributors and other electronic devices (such as halogen transformers) at the back of the appliances.

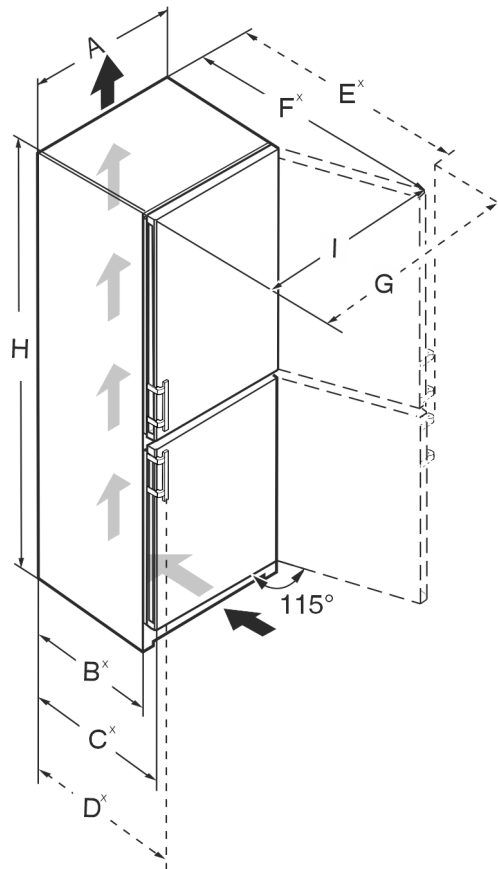

Fig. 2

C5250	
H	1855 mm (73 1/16 in)
A	597 mm (23 1/2 in)
B	611 mm (24 1/16 in) ^x
C	675 mm (26 9/16 in) ^x
D	719 mm (28 5/16 in) ^x
I	846 mm (33 5/16 in)
G	882 mm (34 3/4 in)
F	1178 mm (46 3/8 in) ^x
E	1186 mm (46 11/16 in) ^x
SC5781 / SCB5790IM	
H	2015 mm (79 5/16 in)
A	597 mm (23 1/2 in)
B	611 mm (24 1/16 in) ^x
C	675 mm (26 9/16 in) ^x
D	719 mm (28 5/16 in) ^x
I	846 mm (33 5/16 in)

Ventilation requirements

SC5781 / SCB5790IM	
G	882 mm (34 3/4 in)
F	1178 mm (46 3/8 in) ^x
E	1186 mm (46 11/16 in) ^x

SC7751 / SCB7760IM	
H	2015 mm (79 5/16 in)
A	747 mm (29 7/16 in)
B	610 mm (24 1/16 in) ^x
C	675 mm (26 9/16 in) ^x
D	719 mm (28 5/16 in) ^x
I	1059 mm (41 11/16 in)
G	1096 mm (43 2/16 in)
F	1314 mm (51 3/4 in) ^x
E	1322 mm (52 1/16 in) ^x

CB7790IM	
H	2015 mm (79 5/16 in)
A	747 mm (29 7/16 in)
B	610 mm (24 1/16 in) ^x
C	675 mm (26 9/16 in) ^x
D	–
I	1059 mm (41 11/16 in)
G	–
F	1314 mm (51 3/4 in) ^x
E	–

^x For appliances with supplied wall spacers, the dimension must be increased by 15 mm (5/8 in) (see 9 Mounting wall spacers).

4 Ventilation requirements

NOTICE

Risk of damage due to overheating in the case of insufficient ventilation!

In the case of insufficient ventilation, the compressor can be damaged.

- ▶ Make sure there is sufficient ventilation.
- ▶ Observe the ventilation requirements.

If the appliance is integrated in a fitted kitchen, the following ventilation requirements must be met:

- Basically, the larger the ventilation gap, the more energy the appliance saves during operation.

5 Connection dimensions for the power supply

The connection for the power supply is on the rear of the appliance. In order for you to be able to safely connect your appliance, make sure that the following requirements are met:

- ❑ Dimensions for the power supply connection are known and observed. See the table below.
- ❑ The connection to the power supply is made according to the instructions. (see 16 Connecting the appliance to the power supply)

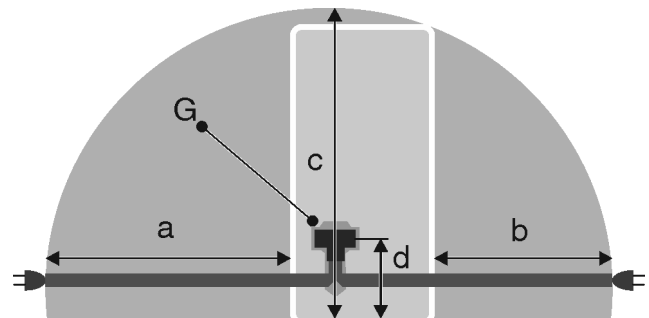

Fig. 3 Fridge/freezer combinations/freezers/full-capacityBio-Fresh appliances

- (a)** Maximum available length of the power cable
- (b)** Maximum available length of the power cable
- (c)** Maximum available vertical length of the power cable
- (d)** Distance of the appliance plug to the floor
- (G)** Appliance plug

For 600 mm (23 1/2 in) wide appliances:*	
a	~ 1800 mm (70 7/8 in)
b	~ 1400 mm (55 1/8 in)
c	~ 2100 mm (82 11/16 in)
d	~ 200 mm (7 7/8 in)

For 750 mm (29 7/16 in) wide appliances:*	
a	~ 1725 mm (67 15/16 in)
b	~ 1325 mm (52 3/16 in)
c	~ 2100 mm (82 11/16 in)
d	~ 200 mm (7 7/8 in)

6 Water connection

If your appliance has a fixed water connection, an elbow connector with screen filter is supplied with it.*

Transporting the appliance

Requirements for the water pressure:	(see 6.1 Water pressure)
Make the water connection:	(see 15 Connecting the appliance to the water supply)

6.1 Water pressure

The water connection line and solenoid valve of the appliance are suitable for a water pressure of up to 1 MPa (10 bar (145.04 psi)).

To ensure that the appliance functions correctly (flow rate, ice cube size, noise level), maintain the following water pressure:

Water pressure:*		
bar*	psi*	MPa*
1.5 to 6.2	21.76 to 87.02	0.15 to 0.62

If the pressure is higher than 6.2 bar (89.92 psi):

- ▶ Connect a pressure reducer.
- ▶ Make the water connection. (see 15 Connecting the appliance to the water supply)

7 Transporting the appliance

Observe the following when transporting the appliance:

- ▶ Transport the appliance upright.
- ▶ Use two people when transporting the appliance.

During the first use:

- ▶ Transport the appliance packaged.

During appliance transport or at first use (e.g. when moving or cleaning):

- ▶ Empty the appliance.
- ▶ Secure the door against undesired opening.

8 Unpacking the appliance

If the appliance is damaged check with the supplier immediately before connecting it.

- ▶ Check the appliance and packaging for damage during transport. If you suspect any damage, please contact your supplier immediately.
- ▶ Remove all materials that could prevent it from being installed properly or prevent proper ventilation from the back or the side panels of the appliance.
- ▶ Remove all protective films from the appliance. Do not use sharp or pointed objects for this.

9 Mounting wall spacers

With the wall spacer, your appliance will achieve the specified energy consumption and no condensation will form in high ambient humidity. The appliance will work properly without using the wall spacer, but with a slightly higher energy consumption.

If you use the wall spacer, the appliance depth increases by approx. 15 mm (5/8 in).

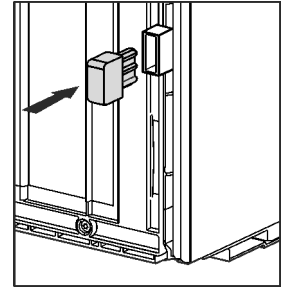

- ▶ Appliance with the wall spacer brackets provided: Install the wall spacer bracket on the rear side of the appliance on the left and right.

10 Setting up the device



CAUTION

Risk of injury due to heavy appliance!

- ▶ Have two people transport the appliance to its installation site.



WARNING

Risk of fire from short circuit!

- ▶ When setting up the appliance: Do not kink, trap, or damage the power cable.
- ▶ Do not operate the appliance with a defective power cable.



WARNING

Danger of injury and damage due to the appliance being unstable!

The appliance can tip over.

- ▶ Secure the appliance as described in the instructions.



WARNING

Danger of fire and damage!

- ▶ Do not place devices that give off heat, e.g. microwaves, toasters, etc. on the appliance.

Make sure that the following requirements are fulfilled:

- Only move the appliance when it is not loaded.
- Always install the appliance with help.
- ▶ Remove the power cable from the enclosed package.
- ▶ Fully insert the IEC socket of the power cable completely into the appliance plug on the rear side of the appliance. Ensure the IEC socket is firmly in place.
- ▶ If necessary, use a string to route the power plug to a socket outlet that is freely accessible.

Setting up the appliance level

11 Setting up the appliance level

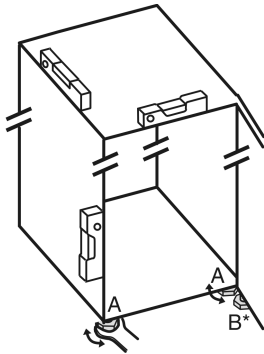

Fig. 4

- ▶ Unscrew the adjustable feet Fig. 4 (A) using the open-end wrench provided and a spirit level until the appliance is firmly aligned and level.



CAUTION

Risk of injury or damage from the appliance tipping or the door falling open!*

If the additional adjustable foot on the base support is not correctly positioned on the floor, there is a risk of the door falling open or the appliance tipping. This can lead to injury or property damage.

- ▶ Unscrew the additional adjustable foot on the swap bearing block as per the instructions.
- ▶ Unscrew the adjustable foot Fig. 4 (B) at the swap bearing block using the open-end wrench provided until it rests on the floor.
- ▶ Turn the adjustable foot Fig. 4 (B) another 90°.
- ▷ Appliance is aligned.

12 After setup

- ▶ Pull off the protective film from the outside of the housing.
- ▶ Pull off the protective film from the trim strips.
- ▶ Pull off the protective film from the trim strips and drawer fronts.
- ▶ Take off the protective film from the stainless steel rear panel.
- ▶ Remove all transport packaging.
- ▶ Clean the appliance. (see operating instructions)
- ▶ Note the type (model, number), appliance designation, appliance/serial number, purchase date and dealer's address.

13 Disposal of packaging



WARNING

Danger of suffocation from packaging materials and films!

- ▶ Do not allow children to play with packaging materials.

The packaging is made from recyclable materials:

- Corrugated card/cardboard
 - Parts made of foamed polystyrene
 - Films and bags from polyethylene
 - Packing bands from polypropylene
 - Wood frame nailed together with a polyethylene window*
- ▶ Take the packaging material to an official collection point.

14 Reversing the door

Tools



Fig. 5

NOTICE

Risk of damage due to colliding doors!

Damage to the appliances if set up Side-by-Side. If you set up two appliances in a specific Side-by-Side arrangement, the door hinges of both appliances are specified from the factory.

- ▶ Side-by-Side setup: Do not change the door hinge.

These sections apply for appliances **with a soft stop mechanism**:

- For appliances **with** a soft stop mechanism
- For all appliances

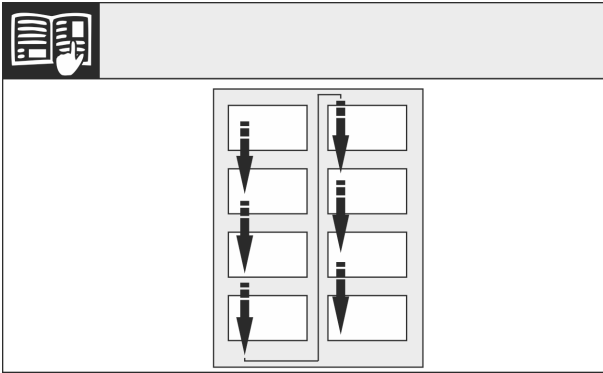

Fig. 6
Observe the reading direction.

14.1 Taking off the top soft stop mechanism*

For appliances with soft stop mechanism:*

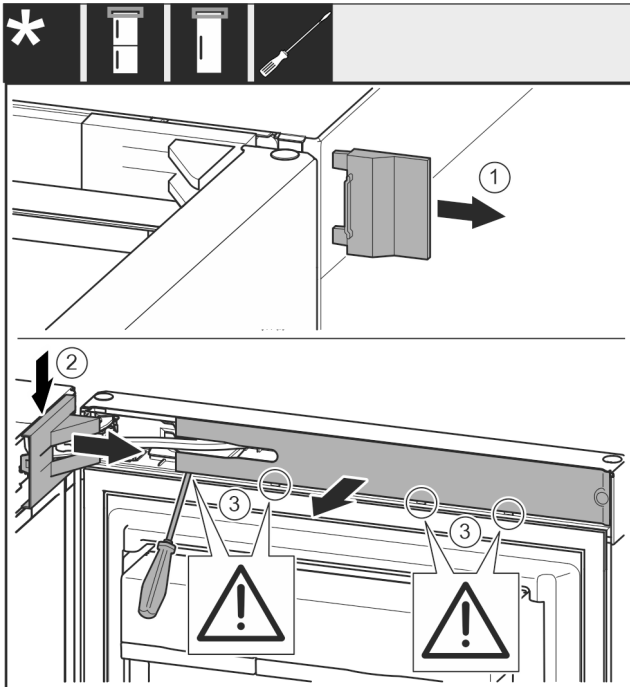

Fig. 7
▶ Open the top door.

NOTICE

Risk of damage!
If the door seal is damaged the door may not close properly and the level of cooling is insufficient.

▶ Do not damage the door seal with the screwdriver!

- ▶ Remove the cover Fig. 7 (1).
- ▶ Snap out the swap bearing block cover Fig. 7 (2) and loosen it.
- ▶ Take off the swap bearing block cover Fig. 7 (2).
- ▶ Use a slotted screwdriver to snap out the faceplate Fig. 7 (3) and swivel it to the side.

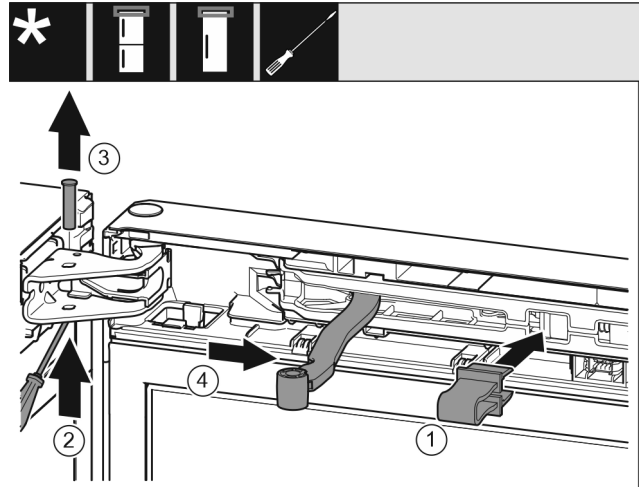

Fig. 8



CAUTION

Crushing hazard from the folding bracket!

▶ Engage the locking device.

- ▶ Snap the locking device Fig. 8 (1) into the opening.
- ▶ Pull out the pin Fig. 8 (2).
- ▶ Pull out the pin Fig. 8 (3) upward.
- ▶ Turn the joint Fig. 8 (4) towards the door.

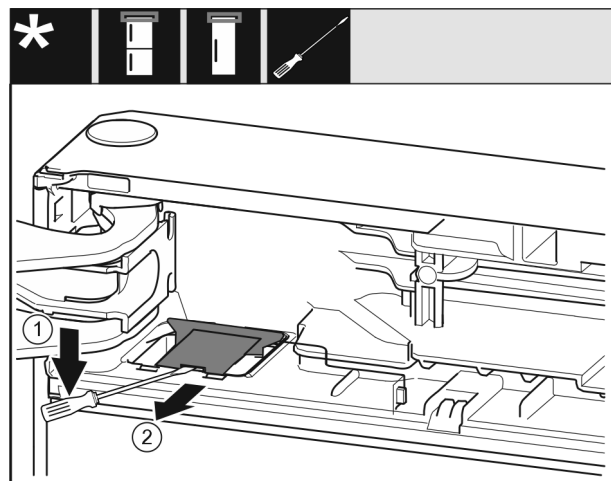

Fig. 9
▶ Use a screwdriver to snap out the cover Fig. 9 (1).
▶ Pull out the cover Fig. 9 (2).

Reversing the door

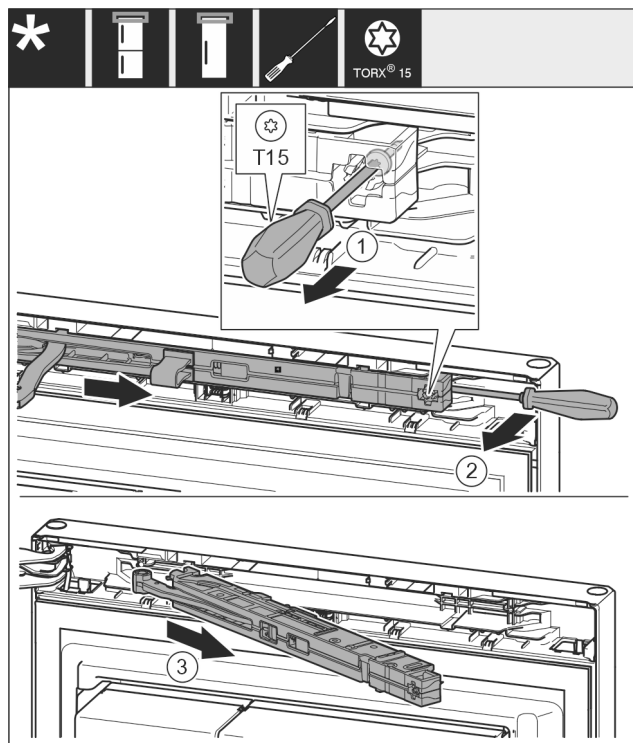

Fig. 10

- ▶ Loosen the screw Fig. 10 (1) on the closing damper unit with a 14 mm (9/16 in) screwdriver.
- ▶ Use the screwdriver to lift out the closing damper unit Fig. 10 (2) on the handle side.
- ▶ Pull out the closing damper unit Fig. 10 (3).

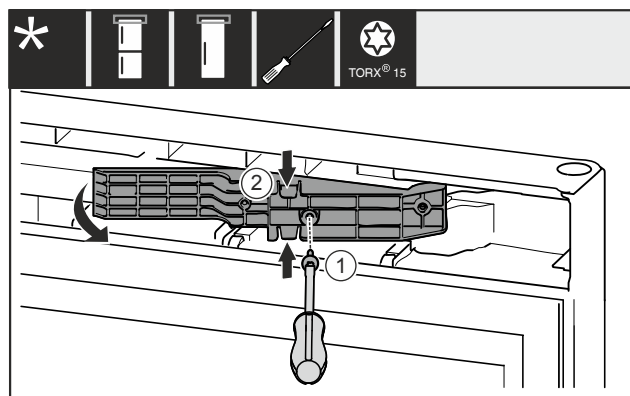

Fig. 11 *

- ▶ Remove the screw Fig. 11 (1).*
- ▶ Gently press the top and bottom of the adapter piece Fig. 11 (2) together and pull it out.*

14.2 Removing the bottom soft stop damper*

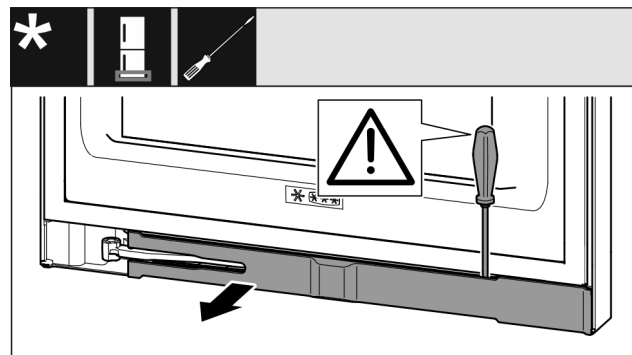

Fig. 12

- ▶ Open the bottom door.

NOTICE

Risk of damage!

If the door seal is damaged the door may not close properly and the level of cooling is insufficient.

- ▶ Do not damage the door seal with the screwdriver!
- ▶ Use a slotted screwdriver to snap out the faceplate and swivel it to the side. (see Fig. 12)

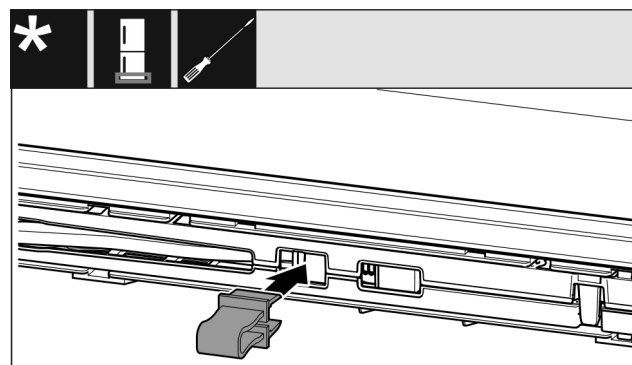

Fig. 13



CAUTION

Crushing hazard from the folding bracket!

- ▶ Engage the locking device.
- ▶ Snap the locking device into the opening. (see Fig. 13)

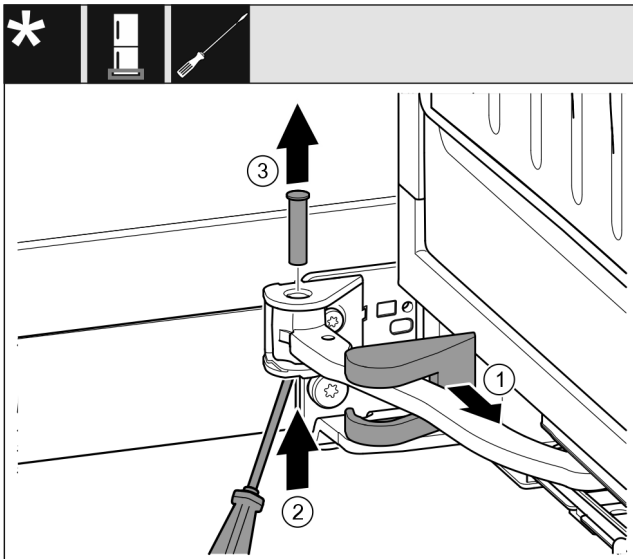

Fig. 14

- ▶ Pull off the swap bearing block cover Fig. 14 (1) and slide it along the joint.
- ▶ Use the screwdriver to lift the pin Fig. 14 (2) from the bottom.
- ▶ Pull the pin Fig. 14 (3) out from the top.

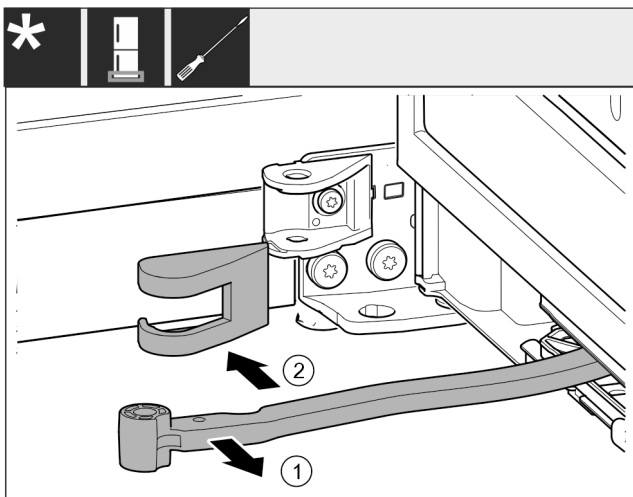

Fig. 15

- ▶ Turn the joint Fig. 15 (1) towards the door.
- ▶ Remove the swap bearing block cover Fig. 15 (2).

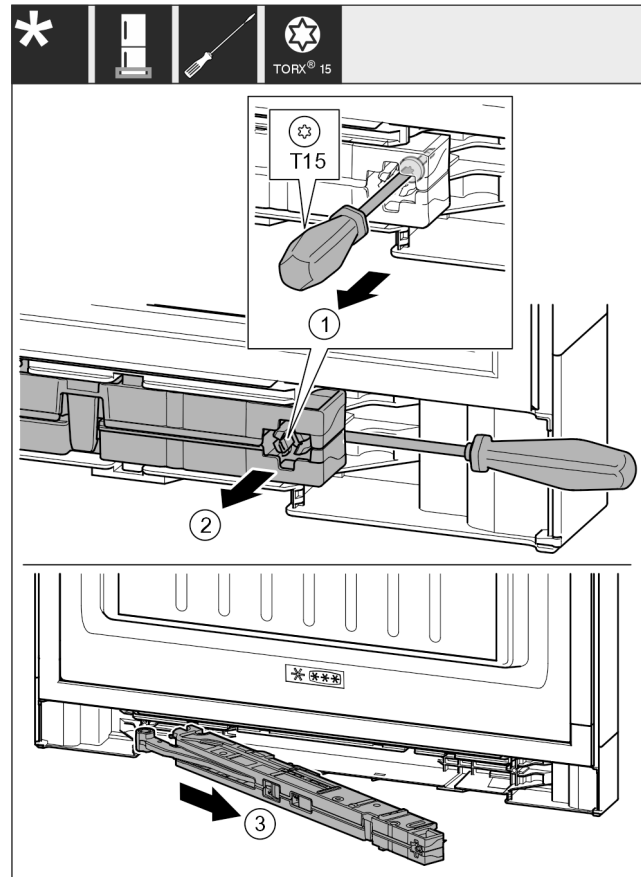

Fig. 16

- ▶ Loosen the screw Fig. 16 (1) on the closing damper unit with a 14 mm (9/16 in) screwdriver.
- ▶ Use the screwdriver to lift out the closing damper unit Fig. 16 (2) on the handle side.
- ▶ Pull out the closing damper unit Fig. 16 (3).
- ▶ Place the soft stop mechanism to one side.

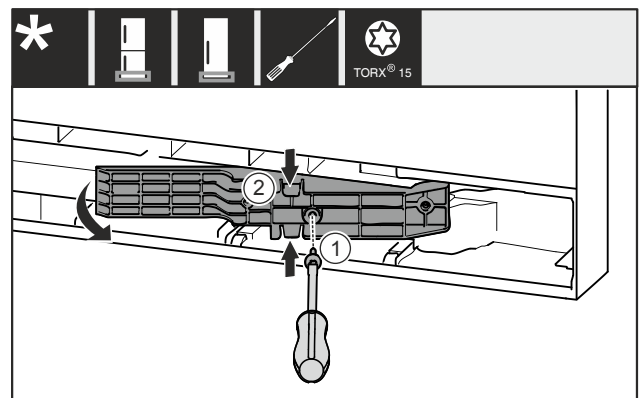

Fig. 17*

- ▶ Remove the screw Fig. 17 (1)*
- ▶ Gently press the top and bottom of the adapter piece Fig. 17 (2) together and pull it out.*

Reversing the door

14.3 Disconnecting the cable connection

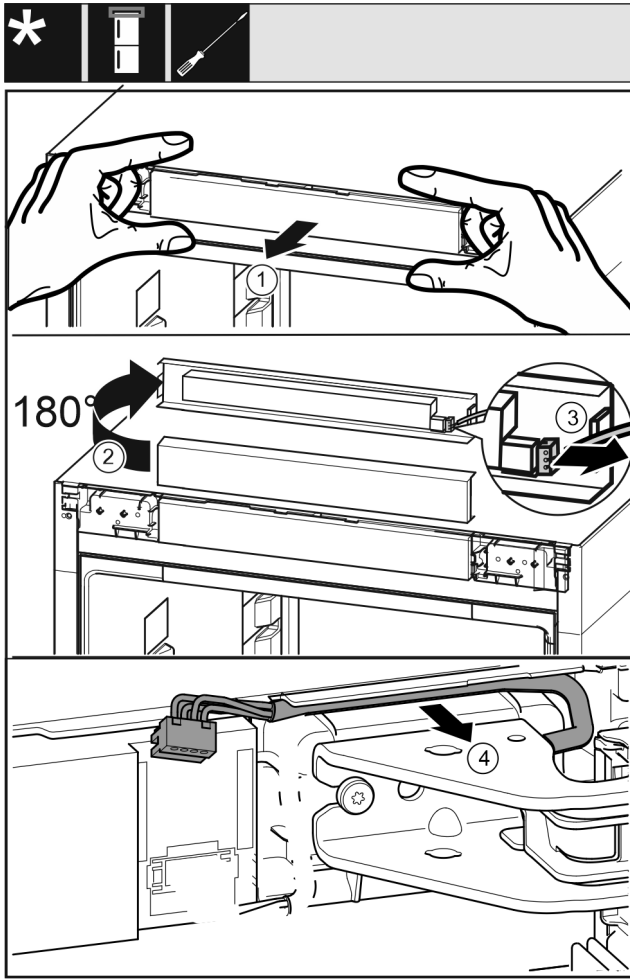

Fig. 18

- ▶ Carefully loosen the control plate Fig. 18 (1) toward the front.
- ▶ Turn the control plate Fig. 18 (2) upward by 180°.
- ▶ Press the latching tab Fig. 18 (3) backwards and carefully pull out the plug.
- ▶ Carefully loosen the cable Fig. 18 (4) above the swap bearing block from the guide.

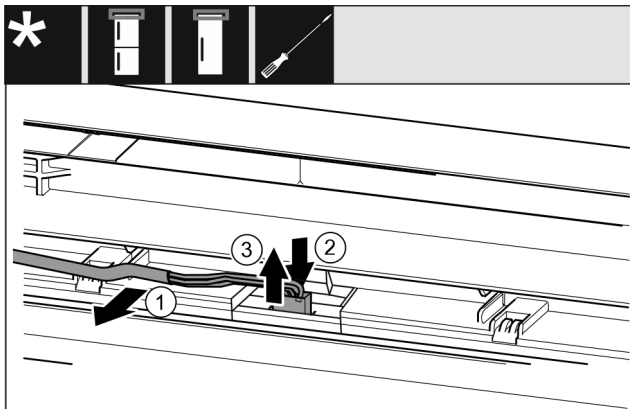

Fig. 19 Fridge/freezer combinations/freezers/cooling units

- ▶ Carefully loosen the cable Fig. 19 (1) from the guide in the door.
- ▶ Press back the tab Fig. 19 (2) behind the plug.
- ▶ Pull the plug Fig. 19 (3) upward carefully.

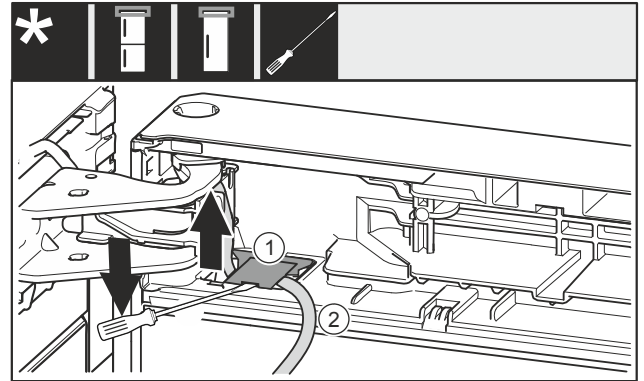

Fig. 20

- ▶ Use the screwdriver to lift up the cover Fig. 20 (1) and pull it out.
- ▶ Pull out the cable Fig. 20 (2).

14.4 Removing the top door

Note

- ▶ To prevent food items from falling out, take all food out of the door racks before removing the door.

For all appliances:

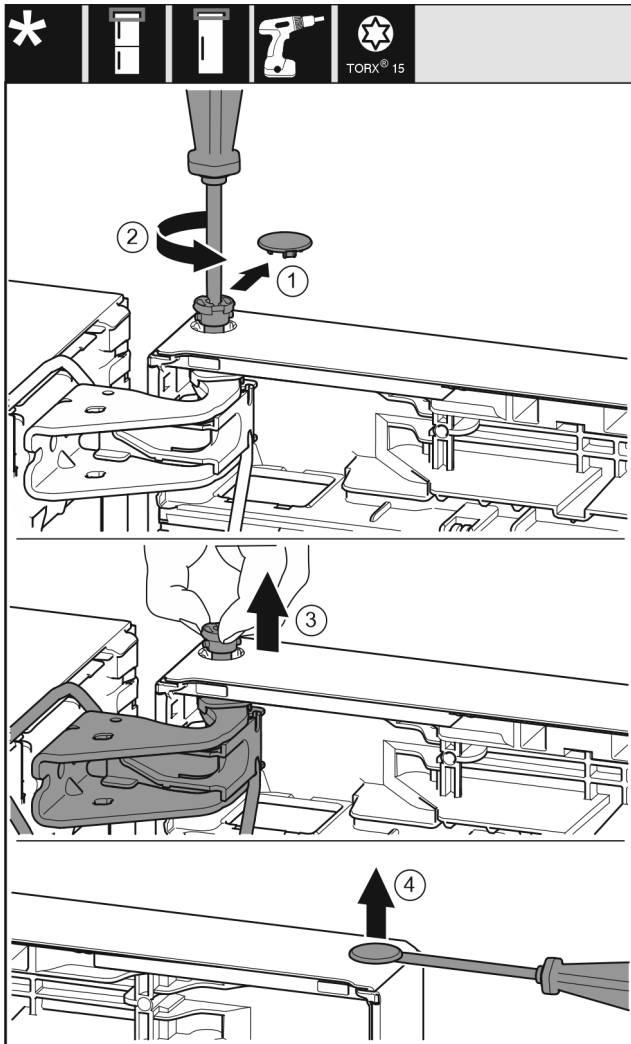

Fig. 21



CAUTION

Risk of injury if the door tips out!

- ▶ Keep a steady grip on the door.
 - ▶ Set the door down carefully.
-
- ▶ Lift the door and place it to one side.

14.5 Removing the bottom door

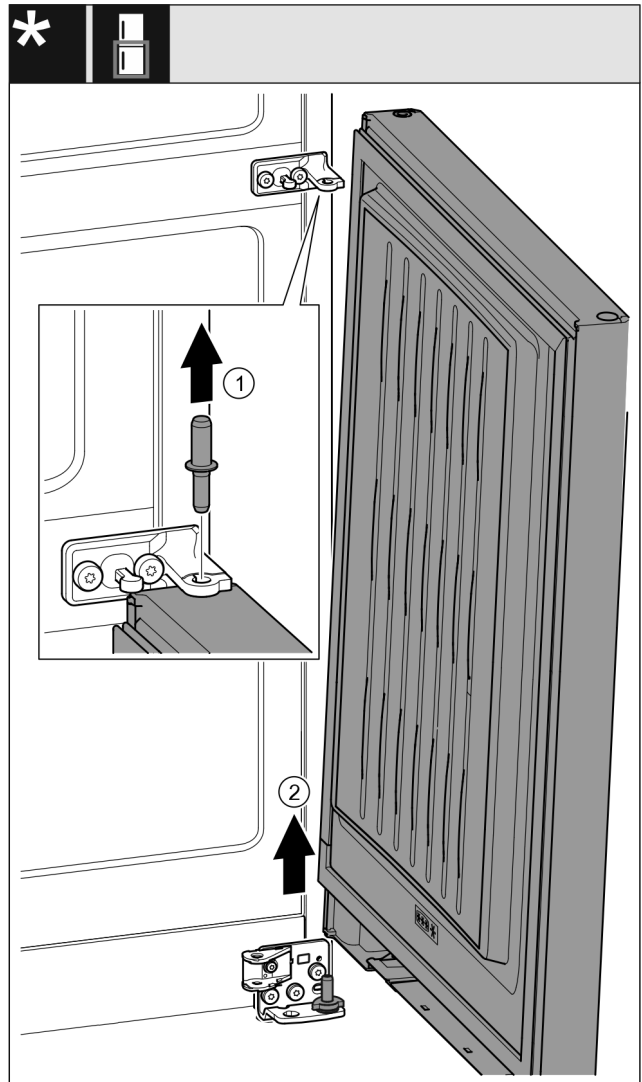

Fig. 22 *



CAUTION

Risk of injury if the door tips out!

- ▶ Keep a steady grip on the door.
 - ▶ Set the door down carefully.
-
- ▶ Pull out the pin Fig. 22 (1) upward.*
 - ▶ Swivel out the door Fig. 22 (2), pull it upward, and set it aside.*

14.6 Moving the upper bearing parts to the other side

For all appliances:

Reversing the door



WARNING

Danger of injury due to door falling out!

If the bearing parts are not screwed on tightly enough, the door may fall out. This can result in serious injuries. In addition, the door may not close causing the appliance to cool improperly.

- ▶ Screw on the bearing brackets/bearing pins tightly with 4 Nm (3 ft lb).
- ▶ Check all screws and retighten them if necessary.

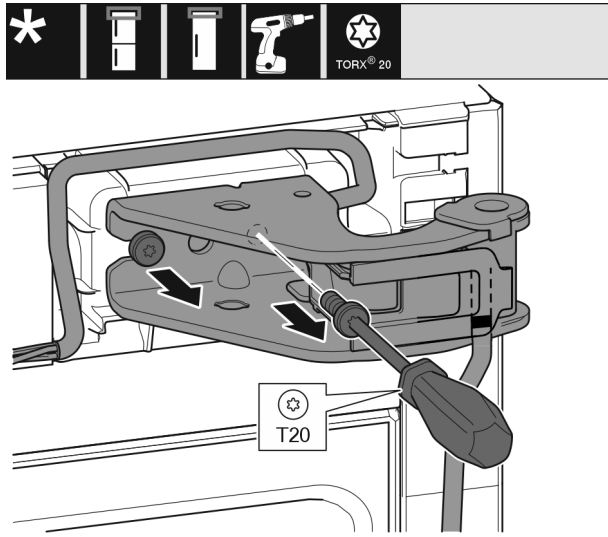

Fig. 23

- ▶ Pull out both screws with the screwdriver.
- ▶ Lift and remove the bearing bracket.
- ▶ Lift and remove the bearing bracket and cable.

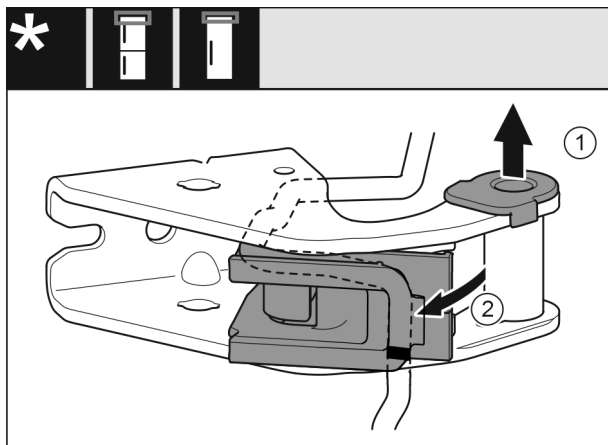

Fig. 24

- ▶ Pull out the bearing bushing Fig. 24 (1) from the guide.
- ▶ Swing out the cable bracket Fig. 24 (2).

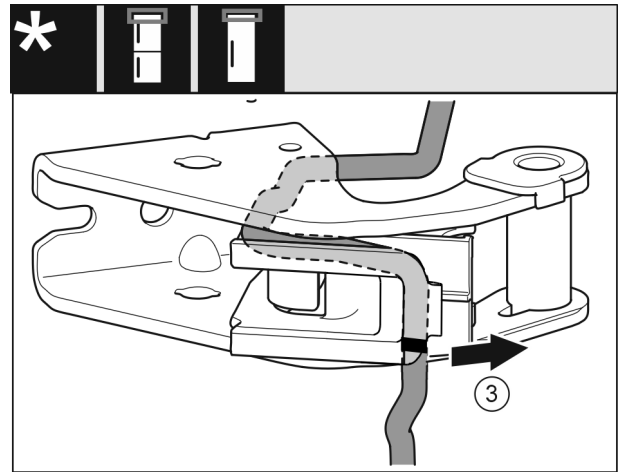

Fig. 25

- ▶ Remove the cable with the cable bracket Fig. 25 (3) from the swap bearing block.

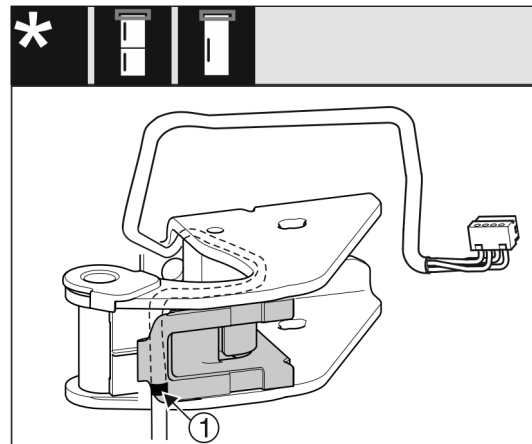

Fig. 26

- ▶ Insert the cable mirror-inverted in the upper groove of the cable holder.
- ▶ The center mark Fig. 26 (1) must be positioned on the edge of the cable bracket.
- ▶ Swing the cable holder in.

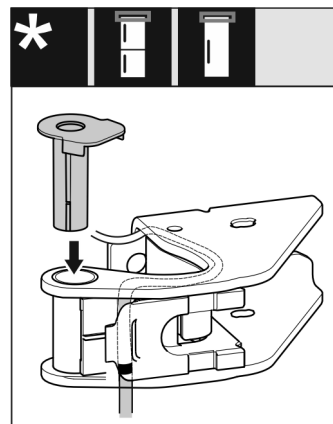

Fig. 27

- ▶ Insert from the other side and latch into place.

NOTICE

Danger of crushing the cable

- ▶ Pay attention to the markings when routing the cable. The cable end with the double marking must be routed into the door end piece.

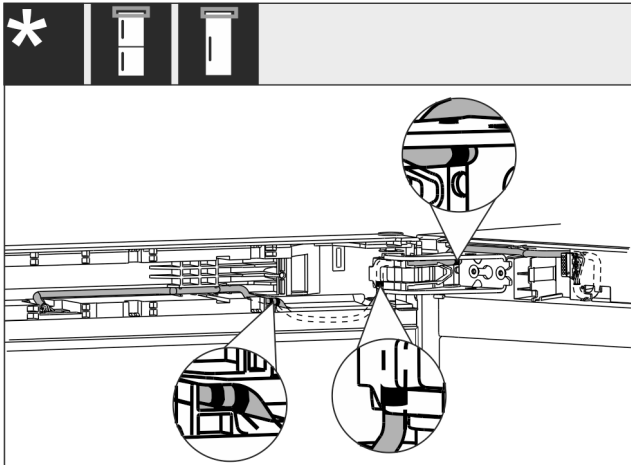

Fig. 28

After making the change, the cable routing must look as shown in the illustration.

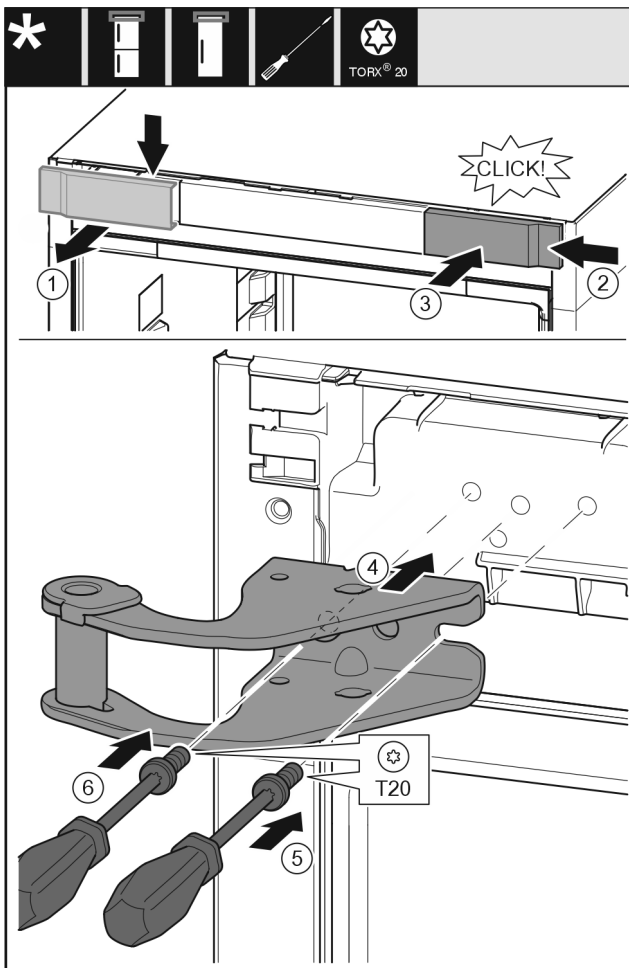

Fig. 29

- ▶ Remove the cover Fig. 29 (1) from the top towards the front.
- ▶ Hang the cover Fig. 29 (2) from the right turned by 180° to the other side.
- ▶ Snap in the cover Fig. 29 (3).
- ▶ Attach the top swap bearing block Fig. 29 (4).
- ▶ Attach and tighten the screw Fig. 29 (5) with a screwdriver.
- ▶ Attach and tighten the screw Fig. 29 (6) with a screwdriver.

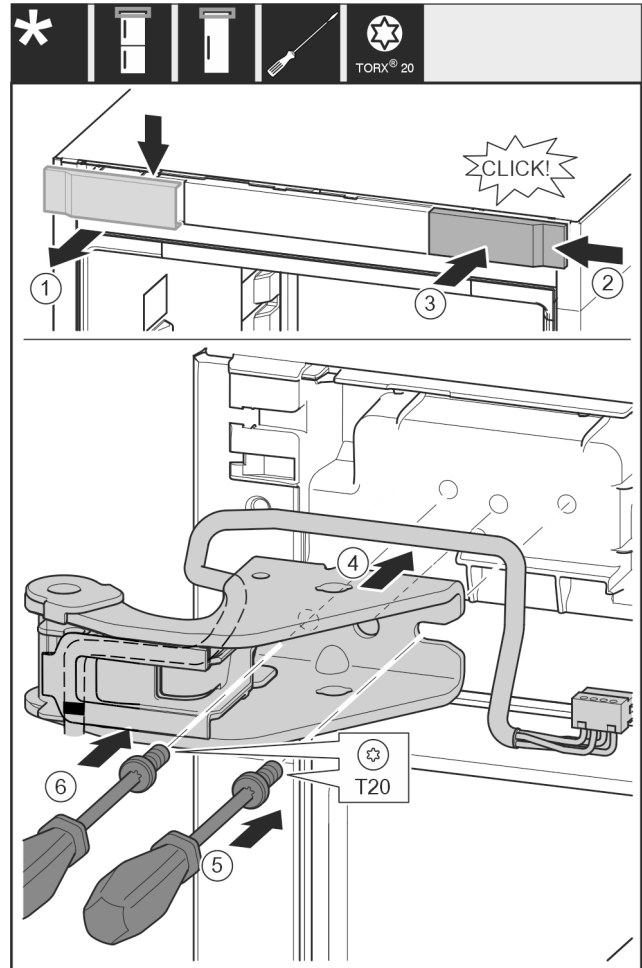

Fig. 30

- ▶ Remove the cover Fig. 30 (1) from the top towards the front.
- ▶ Hang the cover Fig. 30 (2) from the right turned by 180° to the other side.
- ▶ Snap in the cover Fig. 30 (3).
- ▶ Attach the top swap bearing block Fig. 30 (4).
- ▶ Attach and tighten the screw Fig. 30 (5) with a screwdriver.
- ▶ Attach and tighten the screw Fig. 30 (6) with a screwdriver.

Reversing the door

14.7 Moving the central bearing parts to the other side



WARNING

Danger of injury due to door falling out!
If the bearing parts are not screwed on tightly enough, the door may fall out. This can result in serious injuries. In addition, the door may not close causing the appliance to cool improperly.

- ▶ Screw on the bearing brackets/bearing pins tightly with 4 Nm (3 ft lb).
- ▶ Check all screws and retighten them if necessary.

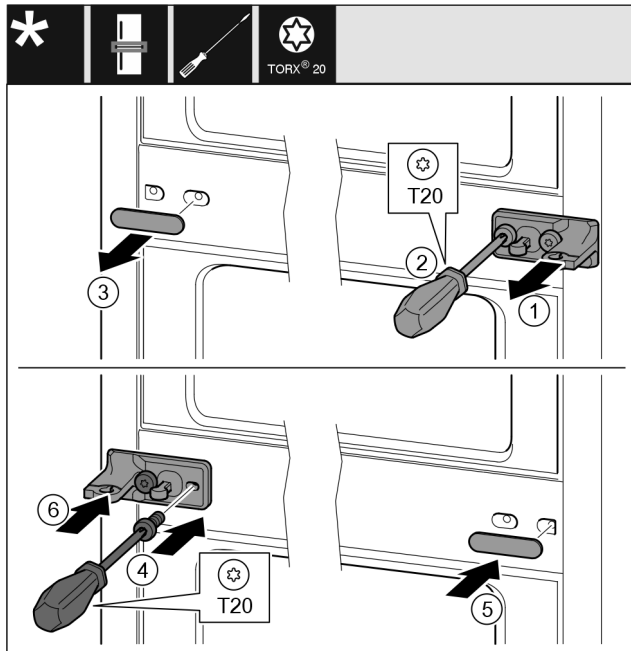

Fig. 31

- ▶ Pull off the washer Fig. 31 (1).
- ▶ Turn out the screws Fig. 31 (2) with the screw driver.
- ▶ Carefully pull off the cover Fig. 31 (3).
- ▶ Tightly screw on the swap bearing block with film Fig. 31 (4) on the other side turned by 180°.
- ▶ Attach the cover Fig. 31 (5) on the other side turned by 180°.
- ▶ Press on the washer Fig. 31 (6) from the front.

14.8 Moving the lower bearing parts to the other side

For all appliances:



WARNING

Danger of injury due to door falling out!

If the bearing parts are not screwed on tightly enough, the door may fall out. This can result in serious injuries. In addition, the door may not close causing the appliance to cool improperly.

- ▶ Screw on the bearing brackets/bearing pins tightly with 4 Nm (3 ft lb).
- ▶ Check all screws and retighten them if necessary.

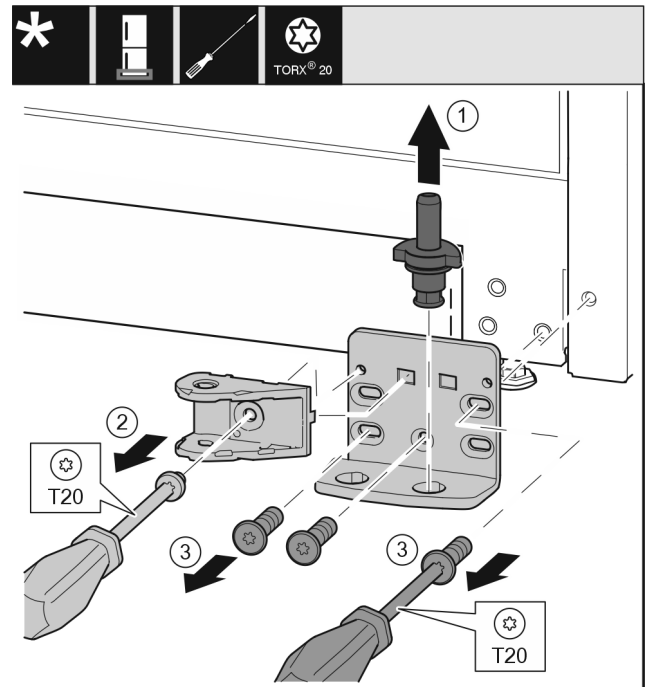

Fig. 32 *

- ▶ Completely pull out the bearing pin Fig. 32 (1) upward.*
- ▶ Use a screwdriver to unscrew the screw Fig. 32 (2) and remove the closing damper connection.
- ▶ Use a screwdriver to unscrew the screws Fig. 32 (3) and remove the swap bearing block.*

For all appliances:

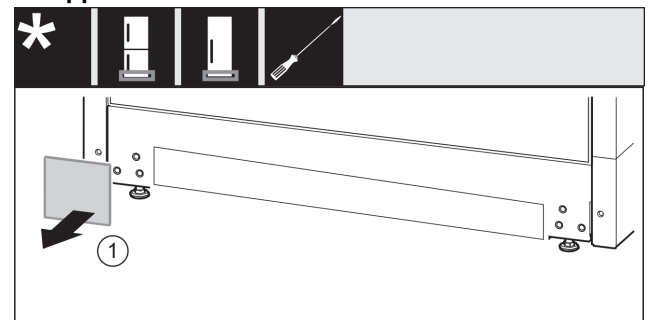

Fig. 33

- ▶ Remove the cover Fig. 33 (1).

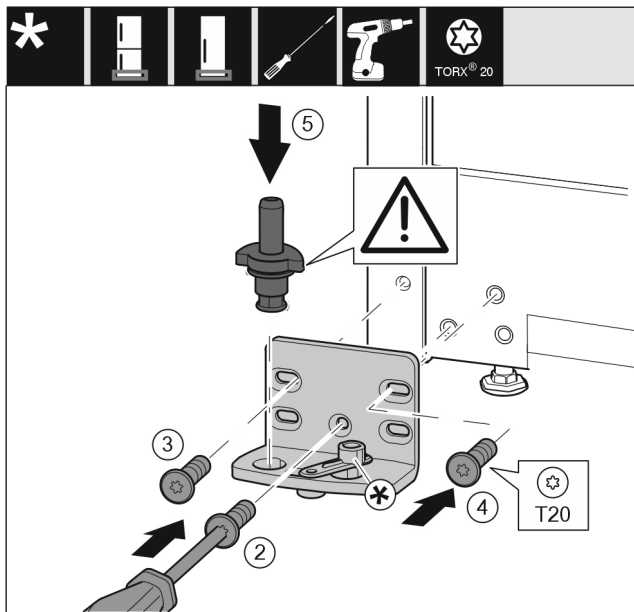

Fig. 34

- ▶ Attach the swap bearing block onto the other side and screw it on using a screwdriver. Start with the screw Fig. 34 (2) at the bottom center.
- ▶ Tighten screw Fig. 34 (3) and screw Fig. 34 (4).
- ▶ Insert the bearing pin Fig. 34 (5) completely. In the process, make sure that the latching cam shows towards the rear.
- ▶ Attach the swap bearing block onto the other side and screw it on using a screwdriver. Start with the screw (2) at the bottom center.
- ▶ Tighten screw (3) and screw (4).
- ▶ Turn the closing damper connection (5) by 180°. On the other side of the swap bearing block, screw it on with the screwdriver.
- ▶ Insert the bearing pin (6) completely. In the process, make sure that the latching cam shows towards the rear.

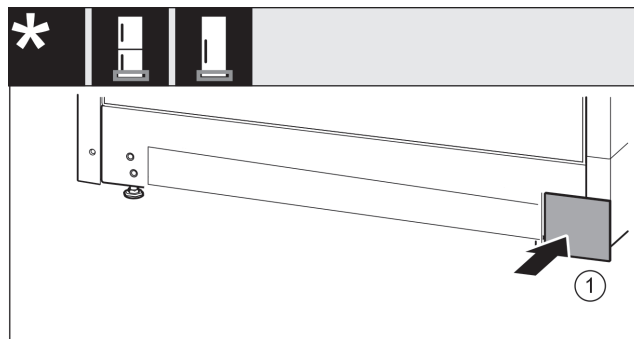

Fig. 35

- ▶ Re-attach the cover Fig. 35 (1) on the other side.

14.9 Moving the door bearing parts to the other side

Top door

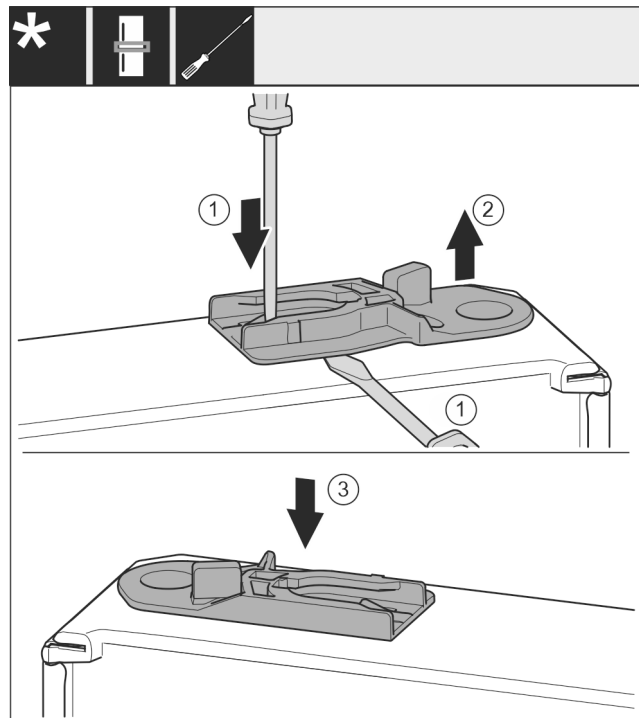

Fig. 36

- ▶ Underside of door faces upwards: Turn the door.
- ▶ Pull out the guide bushing: Press the tab Fig. 36 (1) with the slotted screwdriver while running the slotted screwdriver under the guide bushing Fig. 36 (2) at the same time.
- ▶ Insert the guide bushing Fig. 36 (3) supplied in the scope of delivery on the other side of the housing.
- ▶ Upper side of door faces upwards: Turn the door.

14.10 Moving the handles to the other side

For all appliances:

Reversing the door

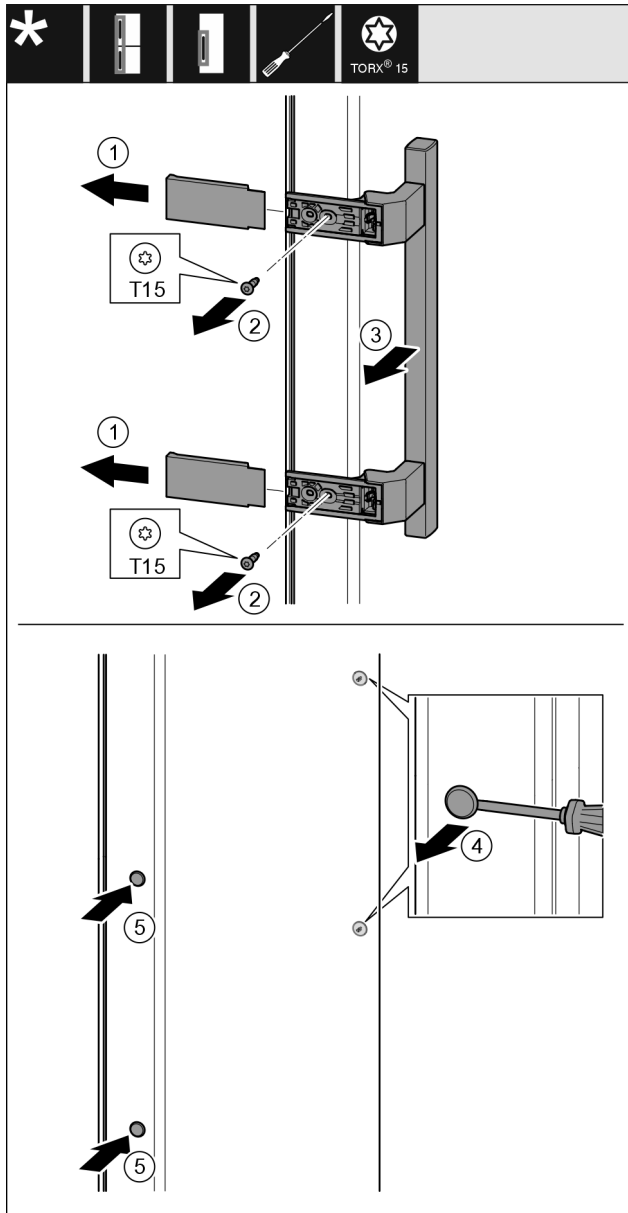

Fig. 37

- ▶ Pull off the cover Fig. 37 (1).
- ▶ Turn out the screws Fig. 37 (2) with the screw driver.
- ▶ Remove the handle Fig. 37 (3).
- ▶ Carefully lift the side plug Fig. 37 (4) with a slotted screwdriver and pull it out.
- ▶ Reinsert the plug Fig. 37 (5) on the other side.

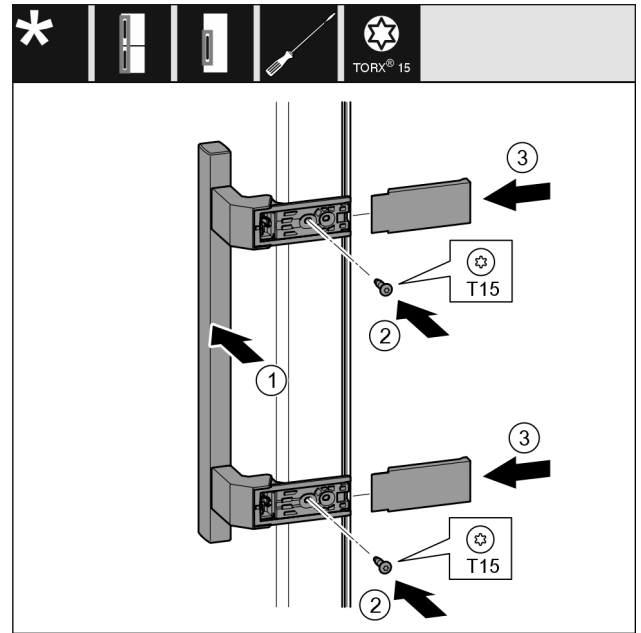

Fig. 38

- ▶ Attach the handle on Fig. 38 (1) the opposite side.
- ▷ The screw holes must be exactly above each other.
- ▶ Tighten the screws Fig. 38 (2) with the screwdriver.
- ▶ Attach the covers Fig. 38 (3) on the sides and slide them on.
- ▷ Ensure that they latch into place correctly.

14.11 Fitting the bottom door

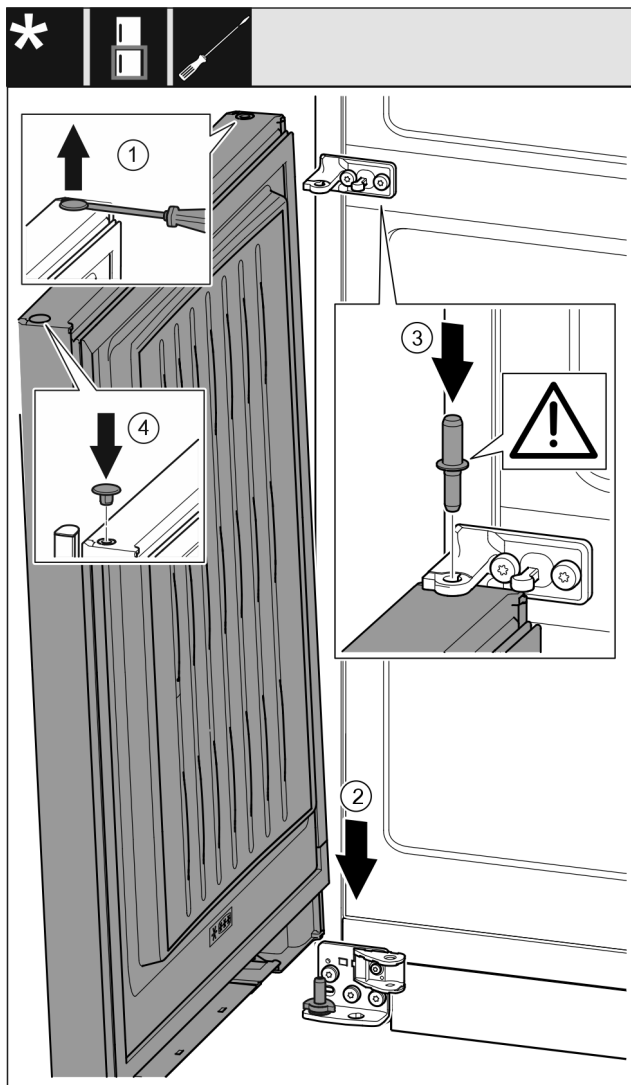

Fig. 39

- ▶ Carefully lift the plug Fig. 39 (1) with a slotted screwdriver and pull it out.
- ▶ Fit the door Fig. 39 (2) onto the lower bearing pin from the top.
- ▶ Insert the center bearing bolt Fig. 39 (3) through the center swap bearing block into the bottom door. In the process, make sure that the latching cam shows towards the rear.
- ▶ Reinsert the plug Fig. 39 (4) on the other side of the door.

14.12 Fitting the top door

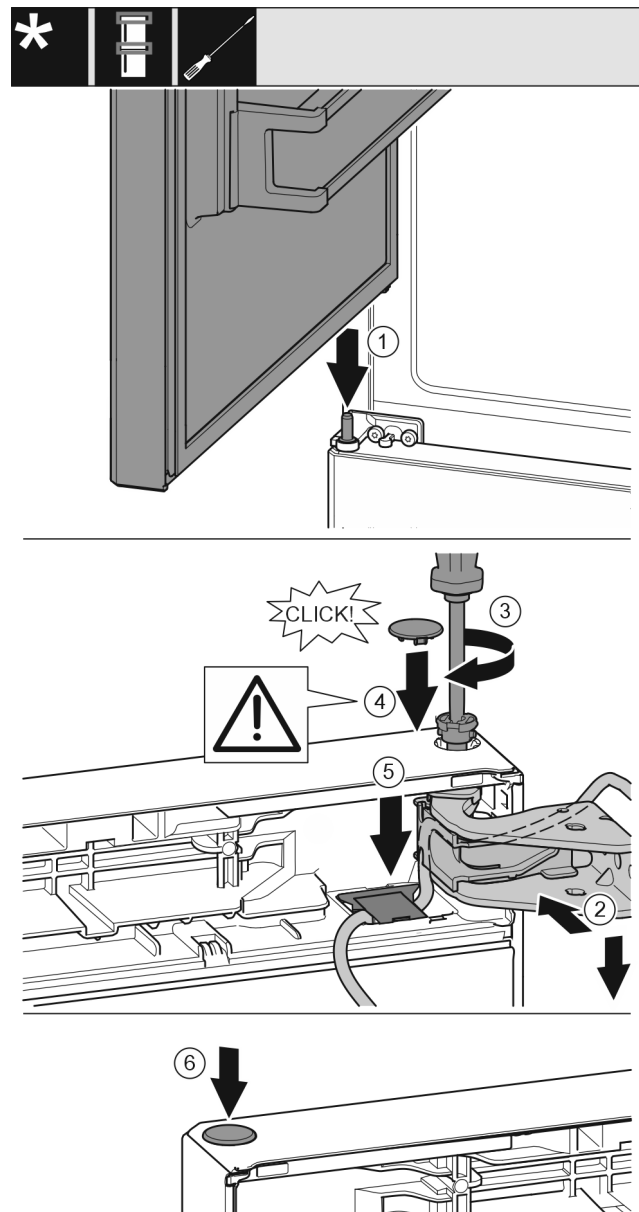

Fig. 40

- ▶ Position to top door onto the center bearing pin Fig. 40 (1).
- ▶ Align the top of the door with opening in the bearing bracket. Fig. 40 (2)
- ▶ Insert the pin Fig. 40 (3) and tighten it with the screwdriver.
- ▶ Mount the safety cover Fig. 40 (4) to protect the door: Insert the safety cover and check whether it is positioned on the door. If so, insert the pin completely.

NOTICE

Cable crushing

- ▶ The marking on the cable must be centered in the holder. The lug with the longer opening must point forwards.

Reversing the door

- ▶ Insert the cover Fig. 40 (5) and press it down until it snaps down.
- ▶ Insert the plug Fig. 40 (6).

14.13 Fitting the cable connection

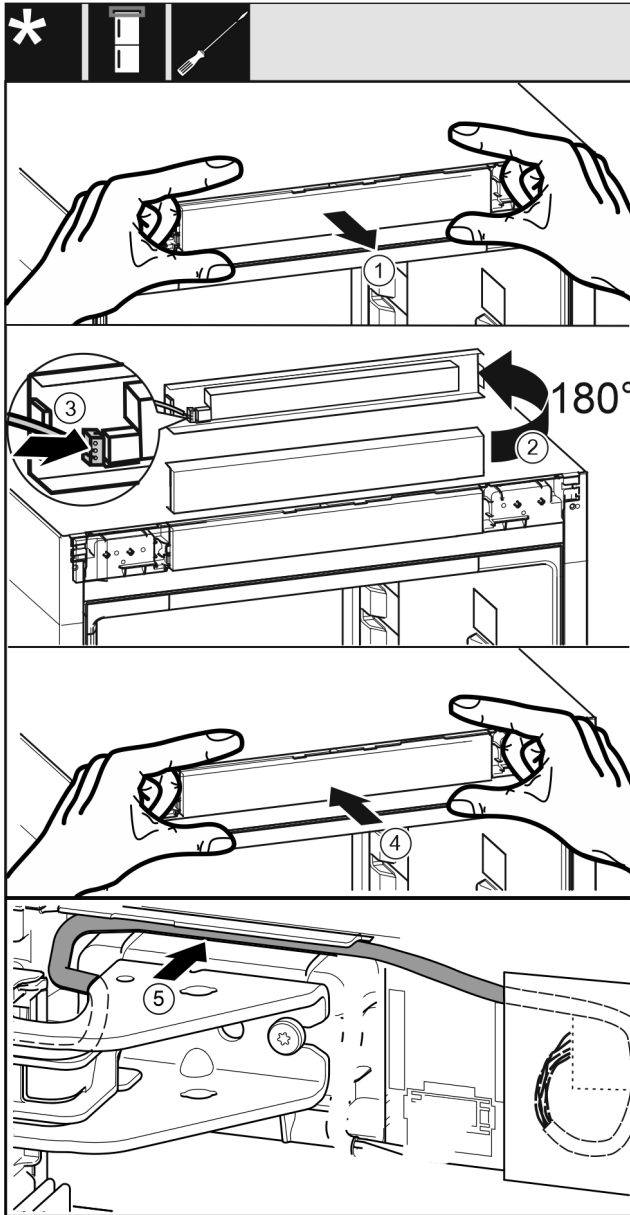

Fig. 41

- ▶ Carefully pull out the control plate Fig. 41 (1).
- ▶ Turn the control plate Fig. 41 (2) upward by 180°.
- ▶ Snap the plug Fig. 41 (3) into place on the control unit panel.
- ▶ Snap the control plate Fig. 41 (4) back onto the appliance.
- ▶ Carefully insert the cable Fig. 41 (5) into the guide above the top swap bearing block.

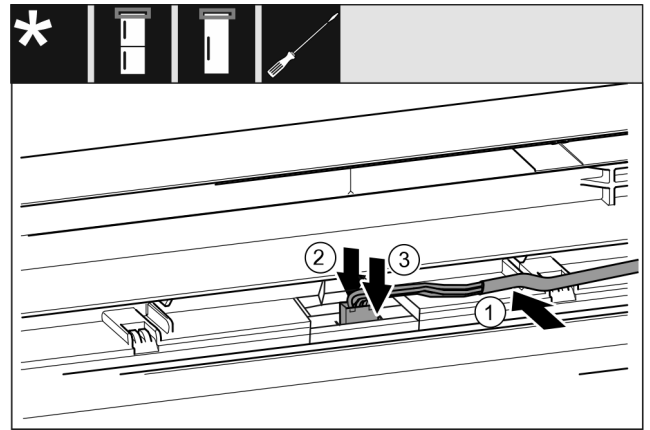

Fig. 42 Fridge/freezer combinations/freezers/cooling units

- ▶ Carefully insert the cable Fig. 42 (1) into the guide in the top door.
- ▶ Press the latching tab Fig. 42 (2) towards the back.
- ▶ Snap in the plug Fig. 42 (3).
- ▶ Position the remaining cable length as a loop in the guide, if required.

14.14 Aligning the doors

For all appliances:



WARNING

Danger of injury due to door falling out!
If the bearing parts are not screwed on tightly enough, the door may fall out. This can result in serious injuries. In addition, the door may not close causing the appliance to cool improperly.

- ▶ Screw the bearing brackets on firmly with 4 Nm (3 ft lb).
- ▶ Check all screws and retighten them if necessary.
- ▶ Align the doors flush with the appliance housing using the two slots in the lower bearing bracket and center bearing bracket if needed. To do this undo the middle screw in the bottom bearing bracket with the T20 tool supplied. Undo the remaining screws a little with the T20 tool or with a T20 screwdriver and align via the slots. Undo the screws in the middle bearing bracket with the T20 tool and align the middle bearing bracket via the slots.
- ▶ Prop up the door: Screw out the adjustable foot on the bearing bracket using the open-ended wrench SW10 until it comes into contact with the floor, then turn an additional 90°.

14.15 Fit the bottom soft stop mechanism

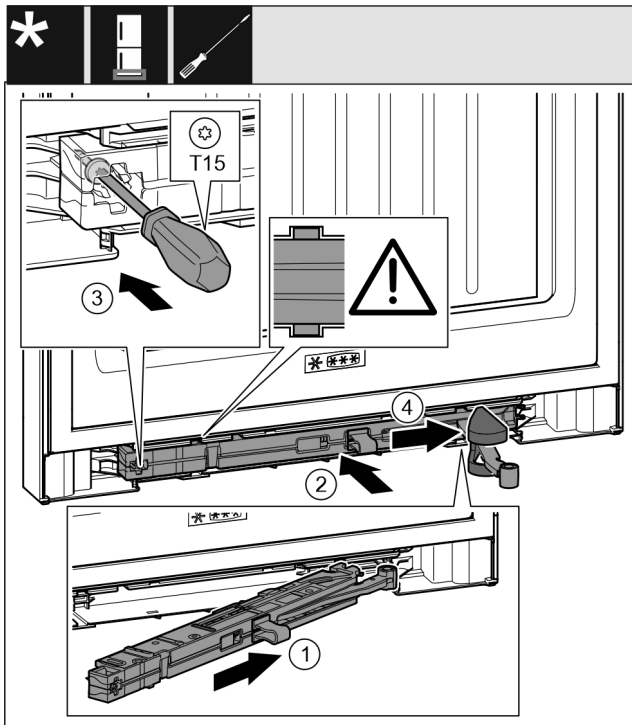

Fig. 43

- ▶ Slide the closing damper unit Fig. 43 (1) on the swap bearing block side up to the stop diagonally into the recess.
- ▶ Push the closing damper unit Fig. 43 (2) completely into the recess.
- ▷ The closing damper unit is positioned correctly if the ridge of the closing damper unit is in the guide.
- ▶ Tighten the screw Fig. 43 (3) with a screwdriver.
- ▶ Push the cover Fig. 43 (4) over the joint.

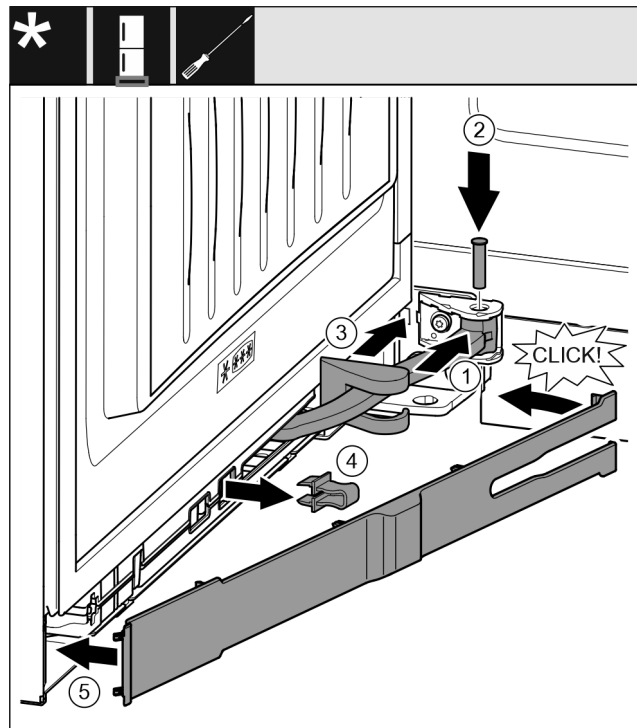

Fig. 44

The door is open 90°.

- ▶ Turn the joint Fig. 44 (1) in the hinged suspension.
- ▶ Use a screwdriver to insert the pin Fig. 44 (2) into the hinged suspension and joint. In the process, make sure that the latching cam is correctly positioned in the groove.
- ▶ Slide the swap bearing block cover Fig. 44 (3) along the joint and install it above the hinged suspension.
- ▶ Remove the locking device Fig. 44 (4).
- ▶ Attach the panel Fig. 44 (5) from the handle side and swivel it on.
- ▷ The panel is clicked into place.
- ▶ Close the bottom door.

14.16 Fitting the top soft stop mechanism

For appliances with soft stop mechanism:

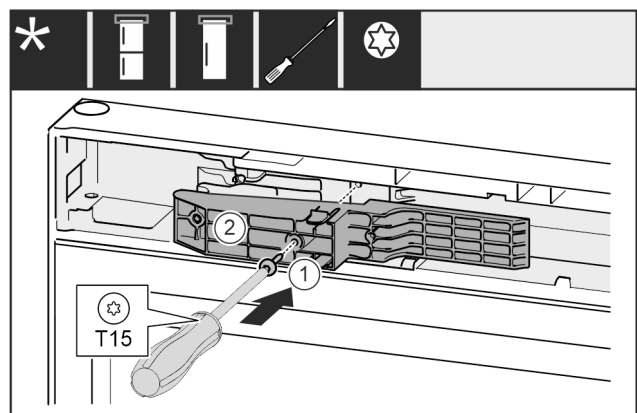

Fig. 45 *

Connecting the appliance to the water supply

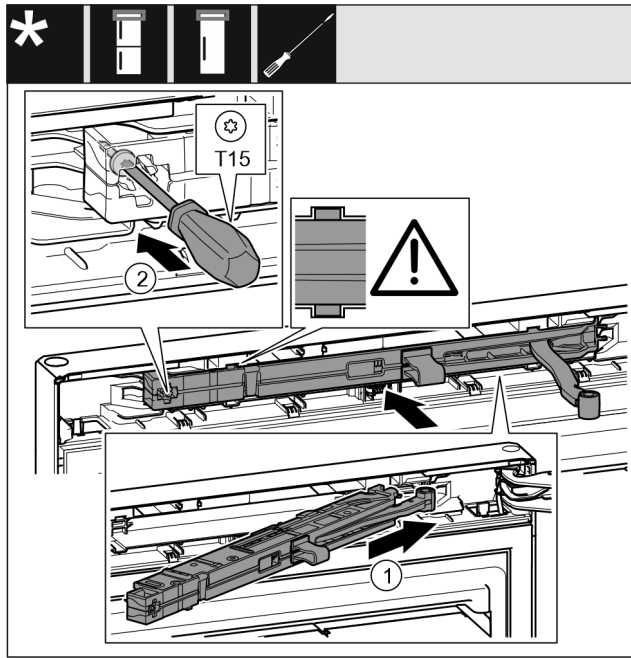

Fig. 46

- ▶ Slide the closing damper unit Fig. 46 (1) on the swap bearing block side up to the stop diagonally into the recess.
- ▶ Slide in the closing damper unit completely.
- ▷ The closing damper unit is positioned correctly if the ridge of the closing damper unit is in the guide in the housing.
- ▶ Tighten the screw Fig. 46 (2) with a screwdriver.

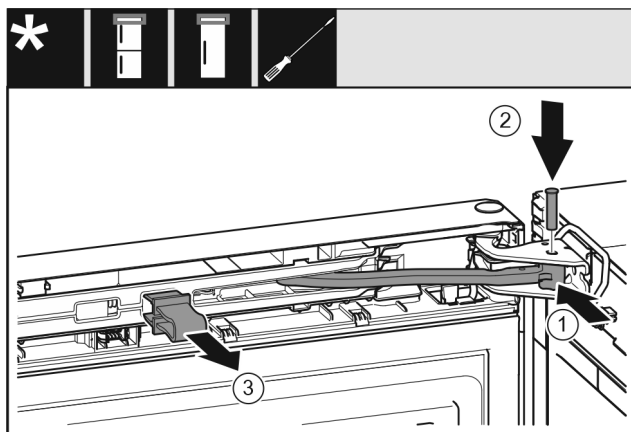

Fig. 47

The door is open 90°.

- ▶ Turn the joint Fig. 47 (1) in the swap bearing block.
- ▶ Insert the pin Fig. 47 (2) into the swap bearing block and joint. In the process, make sure that the latching cam is correctly positioned in the groove.
- ▶ Remove the locking device Fig. 47 (3).

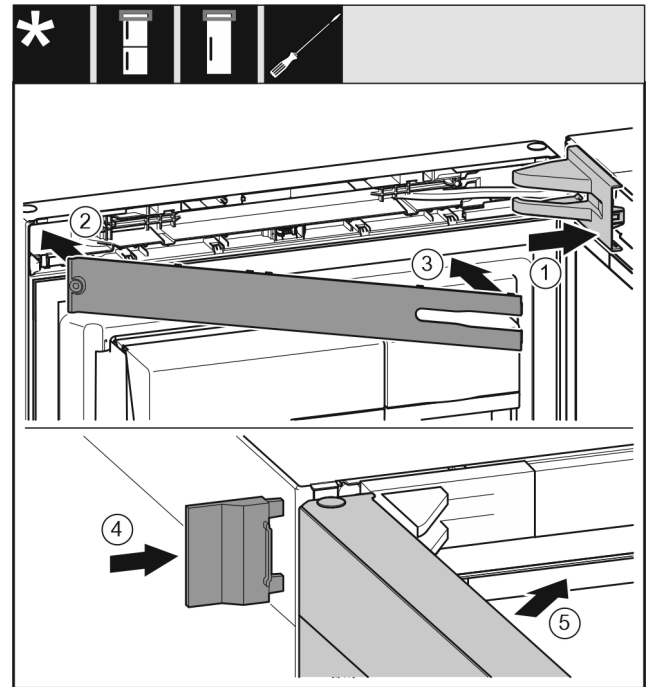

Fig. 48

- ▶ Position the swap bearing block cover Fig. 48 (1) and snap it in. You may need to push it carefully apart.
- ▶ Attach the cover Fig. 48 (2).
- ▶ Cover Fig. 48 (3)
- ▶ Slide on the outer cover Fig. 48 (4).
- ▶ Close the top door Fig. 48 (5).

15 Connecting the appliance to the water supply

Make sure that the following requirements are fulfilled:

- The dimensions for the water supply connection are known and complied with.
- The correct water pressure is maintained.
- Water is supplied to the appliance via a cold water pipe that can withstand the operating pressure and is connected to the drinking water supply.
- All equipment and devices used for the water supply comply with the applicable regulations in the country of use.
- The back of the appliance is accessible so that you can connect the appliance to the drinking water supply.
- A coupler between the R3/4 connection thread and the 1/4" OD copper pipe is supplied.*
- There is a screen filter with a seal in the coupler. The screen filter with a seal is supplied.*
- A **1/4" OD copper pipe** is used to connect the water supply to the solenoid valve. **This is not supplied with the appliance.***

Connecting the appliance to the water supply

- ❑ There is an adaptor between the hose 1/4" OD copper pipe and the domestic water connection so that you can turn off the water supply if necessary.*
- ❑ The adaptor is not directly behind the appliance and is easily accessible. This way, you can push the appliance as close as possible to the wall and can quickly turn off the faucet if necessary.*

WARNING

Risk of electric shock from water!

- ▶ Before connecting to the water hose: Disconnect the appliance from the mains.
- ▶ Before connecting to water lines: Shut off the water supply.
- ▶ Make sure that only qualified personnel connect the device to the drinking water supply.

WARNING

Risk of poisoning due to contaminated water!

- ▶ Connect to potable water supply only.

15.1 Connecting the water pipe*

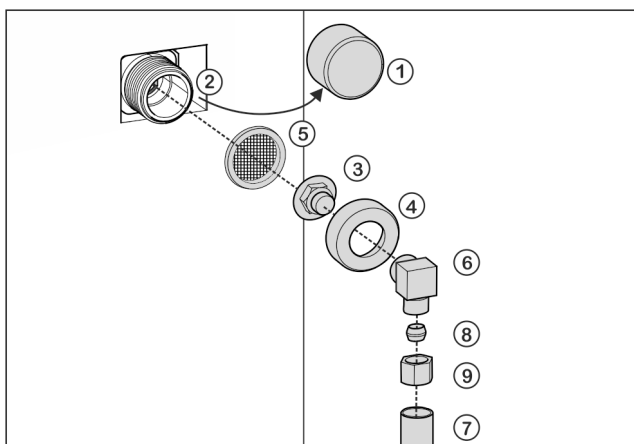

Fig. 49

- | | |
|--------------------|--|
| (1) Cap | (6) Angle piece |
| (2) Solenoid valve | (7) Water pipe (e. g. 1/4" OD copper pipe) |
| (3) Coupler | (8) Clamp ring |
| (4) Union nut | (9) Nut |
| (5) Screen filter | |

NOTICE

Risk of damage from incorrect installation!

- ▶ Do not damage or kink the water pipe (e. g. copper pipe) during installation.
- ▶ Do not damage or kink the water pipe (e. g. copper pipe) when setting up the appliance.

Connecting the coupler to the appliance:

- ▶ Remove cap Fig. 49 (1) from solenoid valve Fig. 49 (2).
- ▶ Insert coupler Fig. 49 (3) into union nut Fig. 49 (4).

NOTICE

The filter can be damaged if not correctly fitted!

- ▶ Observe the following instruction when putting in the filter.
- ▶ Insert the filter Fig. 49 (5) with the recess pointing down towards the coupler Fig. 49 (3).

NOTICE

The thread can be damaged if the union nut is over-tightened!

- ▶ Observe the following instructions for fitting the union nut on the solenoid valve.
- ▶ Screw the union nut Fig. 49 (4) by hand onto the thread of the solenoid valve Fig. 49 (2) until it is firmly in place.
- ▷ The coupler is connected to the appliance.

90° bend in the water connection: Connecting the water hose to the elbow connector:

- ▶ Screw on angle piece Fig. 49 (6).
- ▶ Connect the water pipe Fig. 49 (7) (e. g. 1/4" OD copper pipe) with the clamp ring Fig. 49 (8) and nut Fig. 49 (9) to the elbow connector Fig. 49 (6).
- ▷ The water pipe is connected to the elbow connector.

-or-

No bend in the water connection: Connecting the water hose to the coupler:

- ▶ If necessary: Fasten the water pipe Fig. 49 (7) to the housing with the guide clip.
- ▶ Put angle piece Fig. 49 (6) to one side.
- ▶ Connect the water pipe Fig. 49 (7) (e. g. 1/4" OD copper pipe) with the clamp ring Fig. 49 (8) and nut Fig. 49 (9) to the coupler Fig. 49 (3).
- ▶ If necessary: Fasten the water pipe Fig. 49 (7) to the housing with the guide clip.
- ▷ The water pipe is connected to the coupler.

Fitting the adaptor between the water pipe and the water supply:

- ▶ Connect the water pipe (e. g. 1/4" OD copper pipe) to the water supply with a suitable adaptor.
- ▷ The water is connected to the water supply with an adaptor.

15.2 Check the water system

Before you completely install the appliance, Liebherr recommends checking the water system for leaks.

- ▶ Slowly turn on the water feed.*
- ▶ Check the hose, water feed and connections for leaks.
- ▷ The water system has now been checked for leaks.
- ▷ The water system is not leaking: You can install up the appliance completely.

Note

IceMaker: Before the first use, you must clean the IceMaker. (see Quick Start Guide or operating instructions)

Connecting the appliance to the power supply

16 Connecting the appliance to the power supply



WARNING

Danger of electric shock and injury due to damaged appliance or damaged mains cable!

Cuts and fatal injury. If the appliance or the mains cable is damaged during transport, you may be electrocuted. You could also cut yourself on damaged parts of the appliance housing.

- ▶ Check the appliance and the mains cable for damage after transport.
- ▶ Never put the appliance into operation if the appliance or the mains cable are damaged.
- ▶ Contact Customer Service.

You can connect your appliance to the mains using the power cable supplied separately. The mains power cable has an appliance coupler at one end and a mains plug at the other end.

Make sure that the following requirements are fulfilled:

- The appliance and power cable are undamaged.
- The appliance is set up in accordance with the regulations. (see 9 Mounting wall spacers)
- Requirements for the electrical connection are met. (see 2 Setup conditions)
- Dimensions for connection in accordance with regulations are known and observed. (see 5 Connection dimensions for the power supply)
- Mains voltage and frequency correspond to the specifications on the type plate.
- The socket is grounded and fused in accordance with regulations.
- The tripping current for the fuse is between 10 A and 16 A.
- Outlet is easily accessible and is not behind the appliance. (see 5 Connection dimensions for the power supply)

NOTICE

Danger of damage to incorrect operation!
Damage to the electrical components of the appliance.

- ▶ Only use the supplied power cable.



WARNING

Danger of fire due to incorrect connection!
Burns.

Damage to the appliance.

- ▶ Do not use an extension cord.
- ▶ Do not use a multipoint connector strip.

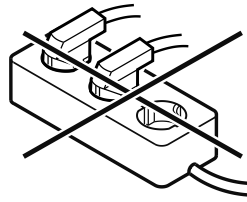

NOTICE

Danger of damage to incorrect connection!
Damage to the appliance.

- ▶ Do not connect the appliance to a stand-alone inverter, e.g. solar power systems and petrol generators.
- ▶ Connect the mains plug of the power cable to the power supply.
 - ▷ The Liebherr logo appears in the display.
 - ▷ The display switches to the standby symbol.
 - ▷ If no action is taken within 60 seconds: Standby symbol fades or disappears.
- ▶ Appliance is connected. For initial commissioning, see the next chapter or the operating instructions.



home.liebherr.com/fridge-manuals

EN Combined fridge-freezer

Issue date: 20241113

Part number index: 7086363-00

For Service in the U.S.: Liebherr Service Center
Toll Free: 1-866-LIEBHER or 1-866-543-2437
Service-appliances.us@liebherr.com
PlusOne Solutions, Inc.
3501 Quadrangle Blvd, Suite 120
Orlando, FL 32817

For Service in Canada: Liebherr Service Center
Toll Free: 1-888-LIEBHER or 1-888-543-2437
www.euro-parts.ca
EURO-PARTS CANADA
39822 Belgrave Road, Belgrave, Ontario, N0G 1E0
Phone: (519) 357-3320 | Fax: (519) 357-1326