

---

# A 922 Rail Litronic

---

## LIEBHERR

Railroad excavator



**Generation**

6

**Operating weight**

45,000 – 51,600 lb

**Engine**

161 HP (I) / 120 kW  
Stage V

Tier 4 Final  
Stage IIIA (compliant)



## Performance

Compact, flexible – perfect combination for maximum performance

## Economy

A sound investment – optimum economy and environmentally friendly

## Reliability

Competence, consistency, innovation – proven experience

## Comfort

Ergonomic excellence – superior cabin design for operator comfort and wellbeing

## Maintainability

Service every step of the way – simple, fast and reliable

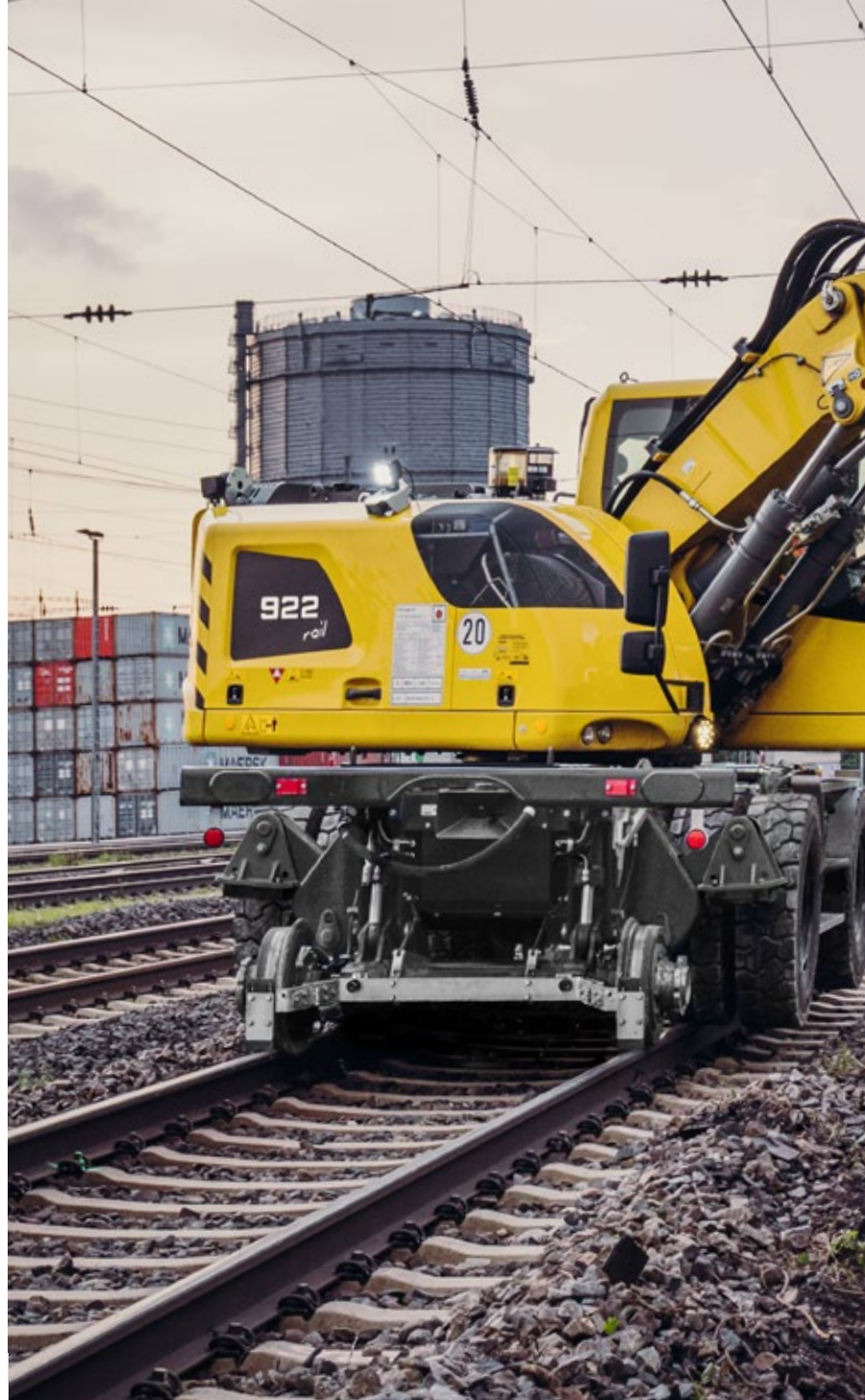





## A 922 Rail

**Operating weight**  
45,000 – 51,600 lb

**Engine**  
161 HP (I) / 120 kW  
Stage V  
Tier 4 Final  
Stage IIIA (compliant)



# Performance

---



## Compact, flexible – perfect combination for maximum performance

Decades of experience, consistent development work and striving to deliver maximum efficiency and performance have resulted in the A 922 Rail. The new generation continues the successful concept of its predecessor with new ideas and improvements. The basis is provided by the powerful construction machinery engine with its high torque which drives Liebherr's powerful, flexible variable-displacement pumps. This means consistently high power is available in every situation.

## Maximum performance

### Maximum performance

A sophisticated machine concept is essential to deliver optimal performance in payloads, stability and flexibility. The new A 922 Rail generation delivers continued, familiar, intelligent superstructure design with a separate boom cylinder mounting and a solid rail chassis to ensure reliable stability and maximum load capacity for track operations. In addition to standard ballasting, a revised heavy ballast weight with a reduced rear swivel radius of 6' 7" ft in is now also available. The maximum payloads can also be increased by a Power Lift mode and an optional 4-point support.

### Liebherr undercarriage

The A 922 Rail is available with a range of undercarriage versions with different gauges, rail wheels and suspension systems enabling it to be used on tracks anywhere in the world. An independent variable-displacement pump for the rail chassis delivers outstanding traction and reliable drive power at all times. The permanent level regulation of the rail chassis enables the machine to travel smoothly on rails.

## Precise work

### Powerful hydraulic concept

The design concept of the A 922 Rail Litronic was developed to deliver maximum performance and flexibility. The new 161 HP (I) (120 kW) construction machinery engine and the perfectly coordinated hydraulic system enables the machine to achieve even higher working speeds with the familiar fluid equipment movements. To achieve greater performance when using attachments, the flow volume of the time-tested double variable-displacement pump (with independent regulating circuits) has been increased to 2 x 58 gpm. Furthermore, the capacity can also be used as the sum of both hydraulic circuits (for example for pile-driving) as in the past. A second high pressure circuit means that three hydraulic functions can be controlled directly on special attachments (for example on tamping devices).

### Working with precision

Many years of experience in the development and production of hydraulic excavators and systems allow us to harmonize the components perfectly. As a result, Liebherr hydraulic excavators feature rapid, fluid movements combined with high precision.



### Constant power

- Powerful and robust construction machinery motor for continuous use at full load
- 4.5 l long-stroke engine for high torque and fuel-efficient work at low speeds
- Efficient turbo loader with intercooling - high output at low fuel consumption



### Improved rail chassis

- Large rail wheels reduce wear and increase the machine's stability
- Easily interchangeable rail wheels make the machine suitable for a wide range of uses



### Time-tested travel drive

- Time-tested travel drive with high traction for high travel speeds on the level and on gradients
- Drive power through direct contact between the rubber tires and the rail delivers massive traction for towing trailers / wagons
- Newly developed drive shaft protection



# Economy

---



## A sound investment – optimum economy and environmentally friendly

Liebherr rail machines combine high productivity and flexibility with economy in factory-standard configurations. The A 922 Rail Litronic is specifically designed to be compatible with a variety of versatile attachments. The machine can work independently and flexibly even on inaccessible sections of track. On request, the efficiency of each wheeled excavator can be further boosted with a Liebherr quick coupling system, resulting in more return from each machine operator hour.

## Maximum efficiency

### Available all over the world

The new A 922 Rail Litronic railroad excavator delivers higher performance data with its new engine coupled with lower fuel consumption and can be supplied with an appropriate exhaust system to meet various national emissions regulations. In the future, this means that the machine will be available in countries with both high and low level regulations. To meet emissions stage V, Liebherr uses a newly developed SCRT system, consisting of an SCR catalytic converter system and a standard particulate filter.

### Engine idling

The standard automatic idling function reduces the engine speed to idle as soon as the operator takes his hand from the joystick so that no hydraulic function is activated. Proximity sensors in the joystick levers restore the original engine speed as soon as the operator's hand is moved towards the lever again. This ensures that the set engine speed is available immediately. The result is a combination of fuel saving and reduced noise level.

## Increased productivity

### Liebherr attachments and LIKUFIX

To boost the productivity of its construction machines, Liebherr offers a broad range of attachments for different fields of application. Furthermore, the hydraulic excavators can also be equipped with the Liebherr LIKUFIX hydraulic quick coupling system. The combination of a hydraulic Liebherr quick coupling system with the LIKUFIX coupling block permits fast safe changing of mechanical and hydraulic attachments from the operator's cabin. This boosts productivity on average by 30%. The construction process is accelerated, and orders are completed faster. That enables more turnover to be achieved per machine.

### Efficient management

LiDAT, Liebherr's own data transmission and positioning system, facilitates efficient management, monitoring and control of the entire fleet in terms of machinery data recording, data analysis, fleet management and service. All of the important machinery data can be viewed at any time in a web browser. LiDAT provides you comprehensive work deployment documentation, greater availability thanks to shorter downtimes, faster support from the manufacturer, quicker detection of strain / overload and subsequently a longer service life of the machine as well as greater planning efficiency.



### Wagon braking system

- Availability of various wagon braking systems for safe railway operation
- Can be configured flexibly depending on wagon type (hydraulic / pneumatic / single or dual circuit)



### Adjustable gauge axle

- Can be adjusted to various gauges (narrow, standard and wide gauge)
- Simple adjustment of gauge
- Suitable for worldwide use



### Liebherr quick coupling system LIKUFIX

- Faster and safer changing of mechanical and hydraulic attachments from the cab
- Extended applications and control due to signal contact strip between the attachment and the hydraulic excavator
- Optical and acoustic check of the correct closure of the locking mechanism on the attachment to the quick coupler unit using two proximity sensors



# Reliability

---



## Competence, consistency, innovation – proven experience

Reliability contributes to safety and safety influences the success of a project. Liebherr stands for safety with reliable railroad machines used on rail, in rough terrain or on the road. Our comprehensive security functionality pays off.



## More safety

### Quality and competence

Liebherr has been developing and manufacturing hydraulic excavators since 1954 and has built railroad excavators since 1967. Our product experience, our understanding of technical design and feedback from customers, sales and service personnel formed the basis for our construction of pioneering ideas and have been part of our successful recipe throughout the company history. Key components such as electronic parts, the slewing ring, slewing drive and hydraulic cylinders are developed and manufactured in-house. Our great production depth guarantees maximum quality and ensures that the components are perfectly coordinated with each other.

### Robust construction

All the steel components are designed and manufactured by Liebherr. High strength steel sheets designed to withstand the harshest requirements guarantee high torsion resistance and excellent absorption of forces to ensure a long service life.

## High machine availability

### Safety

Besides the performance and efficiency of a railroad excavator, the safety of the operator and the machine must always be paramount. Numerous equipment features such as the standard pipe fracture safety valves on the lifting and stick cylinders, electronic lift limitation, electronic swivel limitation, load moment limitation according to EN 15746-2, laminated safety glass smash-resistant, rollover protection structure (ROPS) and an emergency exit through the rear window provide maximum safety in all operations.

### Light and durable

Various LED lights illuminate the working area to deliver excellent visibility and a high level of safety for both man and machine. Our LED lights not only look good, but also deliver excellent luminosity and an extremely long service life. To comply with the appropriate standards in the various destination countries, the machine can be fitted with additional railway-specific lighting at the factory.



### QPDM – Quality and process data management

- QPDM allows production data to be logged, documented and evaluated
- Automation of documentation and test specifications
- Ability to handle large quantities and maintain uniform high quality

### Rail wheel brakes

- Standard integral brakes in the rail wheels reduce the braking distance in every situation to enhance safety on the tracks
- The brakes are also effective when the machine is raised

### Safety systems

#### Straight from the manufacturer

- The basic machine, rail undercarriage and safety systems all come from a single source
- The safety concept includes technologies such as load torque limitation, lift limitation in height, swivel limitation and the virtual wall
- Specially developed for use on rails



# Comfort

---



## Ergonomic excellence – superior cabin design for operator comfort and wellbeing

The modern interior design of the large Liebherr double cab with standard roll-over protection system (ROPS) provides conditions to work in comfort, which enhances concentration and productivity. Thanks to the double seat layout, the cab supports two-man operation required in many countries in which another person monitors the rear and can press a horn or emergency stop switch in an emergency situation. Access to the cab is made easy for both seats by entry lighting. Clarity, ergonomics and safety are the properties we strive for when creating the control concept. That means we avoid time-consuming re-familiarization phases and allow the operator to work efficiently in the machine straight away.



## First-class cab

### Automatic air conditioning

The automatic air conditioning offers intuitive operation. Temperature, blower settings and the various air nozzles in the head, chest and foot areas are set using the touch screen on the indicating unit. The defrost/defog one button function clears fogged up windows in the shortest possible time. The filter for the cab air can be changed easily and conveniently from the outside.

### Operator seats

The Standard, Comfort and Premium operator's seat versions deliver maximum comfort. Even the standard operator seat offers an extensive range of features such as air suspension, seat heating, headrest, lumbar support and many more. Luxuries which we believe every construction machine should provide.

### Low noise levels

The use of viscoelastic mounts, good insulation and low noise diesel engines minimizes noise emissions and vibrations. The noise levels are just 70 dB(A) in the operator's cab and 101 dB(A) outside.

## Comfortable operation

### Radio with hands-free device

The optional Liebherr radio is MP3-compatible, has a USB connection and can be used as interface for the integral hands-free kit. If the machine operator connects his smartphone to the radio using Bluetooth, the touchscreen can be used to control phone calls. This means that all media, including the radio, MP3 or phone calls, are controlled using a central unit which provides greater clarity, simplicity and comfort.

### Excellent all around vision

The familiar large windows combined with the standard rear and side cameras deliver excellent visibility of the working and slewing areas. This visibility enhances the operator's safety and ensures that the machine can be handled safely at all times.



### Joystick with proportional control

- Good functionality with streamlined, ergonomic design
- 4 way mini joystick enables versatile control possibilities without having to encompass, for example, steering, outriggers or attachments
- Two buttons and a rocker switch also increase the number of functions



### Easy access

- Convenient, safe entry and exit into and out of the cab thanks to greater width provided by the folding arm console
- Three standard steps with non-slip galvanised plates to enhance safety
- LED entry lighting can be controlled from outside



### Intuitive operation

- Display of the machine data and camera image on two 9-inch displays with touch screen and direct access via menu bar
- 20 user-programmable memory slots for attachments, which can be used for quickly and easily setting the oil pressure and oil flow at the push of a button when changing attachments
- Quick access keys can be programmed by the machine operator for frequently used menu items



# Maintainability

---



## Service every step of the way – simple, fast and reliable

Liebherr railroad excavators are not only powerful, robust, precise and efficient, they also have an impressive service-oriented design. Maintenance is performed quickly, simply and safe. This reduces maintenance costs and keeps machine downtimes to a minimum.



## Simplified maintenance concept

### Service-based machine design

The service-based machine design guarantees short servicing times, thus minimizing maintenance costs due to less downtime. All the maintenance points are easily accessible from the ground and easy to reach due to the large, wide-opening service doors. With the new generation, the accessibility to important components is even further improved. Air, oil and fuel filters, the main battery switch, the lubricating nipple for the oscillating axle and the pilot valves for emergency actuation are much easier to access. This means that service work can be completed even more quickly and efficiently.

### Hydraulic oils with added value

Liebherr hydraulic oils achieve a service life of 6,000 operating hours plus. Instead of having defined change intervals, the results of the oil analysis (every 1,000 operating hours or after one year) determine when the oil needs to be changed. The unique Liebherr Hydraulic Plus oil can even achieve a service life of 8,000 operating hours and more at the same time as reducing fuel consumption by up to 5%.

## Your competent service partner

### Remanufacturing

The Liebherr remanufacturing program offers cost-effective reconditioning of components to the highest quality standards. Various reconditioning levels are available including replacement components and general overhaul or repair. The customer receives components with original part quality at a reduced cost.

### Competent advice and service

Competent advice is a given at Liebherr. Experienced specialists provide advice for your specific requirements: application-oriented sales support, service agreements, cost effective repair alternatives, original parts management, as well as remote data transmission for machine planning and fleet management.



### Lubricating during work

- Fully automatic central lubrication system for the equipment and slewing ring
- Can be optionally expanded to the connecting link and quick coupler
- The grease tank of the central lubrication system is located behind the left service door
- Works without interrupting work for higher productivity



### Maintenance without draining oil

- Standard shut-off valve for disconnecting the oil tank from the hydraulic system
- For simple maintenance work on the hydraulic components without draining the hydraulic oil
- Reduced maintenance time for higher machine availability



### Rapid spare parts service

- 24-hour delivery: Spare parts service is available for our dealers around the clock
- Electronic spare parts catalogue: Fast and reliable selection and ordering via the Liebherr online portal
- With online tracking, the current processing status of your order can be viewed at any time



# Railroad excavator

## A 922 Rail Litronic overview

---

### Superbly designed equipment for maximum reliability

- Second high pressure circuit
- Safety features such as load torque limitation, lift limitation in height, swivel limitation and the virtual wall
- Liebherr hydraulic cylinders
- Pipe fracture guards for hoisting, adjustment and stick cylinders
- Optimized bucket stick for application under electrical overhead lines
- Liebherr quick coupling systems (optional)
- Wide selection of Liebherr attachments (optional)
- Tool Control for attachments

### Sophisticated maintenance concept for maximum productivity

- Fully automatic central lubrication system for uppercarriage and equipment
- Large, wide-opening service doors
- Central maintenance points accessible from the ground
- Shut-off device for hydraulic oil
- Liebherr hydraulic oil, biologically degradable (optional)
- Cab air filter can be replaced quickly and conveniently from outside
- Two lockable storage boxes
- Interchangeable rail wheels





## Ergonomic operator's work station for maximum comfort

- Double cab with passenger seat
- Operator's seat Comfort or Premium (optional)
- Automatic air-conditioning system
- Two 9" high resolution colour display with touchscreen operation
- Operator personalization
- Resonant arm console and ergonomic joysticks
- Proportional control with 4-way mini-joystick
- Large windows
- Windshield wiper with interval switching and washer, roof window and rear window
- Convenient radio operation with hands-free device
- LED headlights
- Rear and side camera monitoring
- Lighting for cabin access

## Intelligent technology for maximum performance and economy

- Diesel engine with up to date emissions Stage V, Tier 4 Final, Stage IIIA (compliant)
- Dual-circuit load-sensing-control
- Liebherr-Power-Efficiency (LPE)
- MODE selection (Sensitive, ECO, Power, Power-Plus)
- Sensor-controlled automatic idling system
- Double variable-displacement pump (with independent regulating circuits)
- Different gauges and rail wheels possible
- Independent variable-displacement pump for the rail undercarriage
- Improved rear ballast (heavy) with 2,000 mm rear swivel radius (optional)



# Technical data



## Diesel engine

<b>Rating per SAE J1349 / ISO 9249</b>	161 HP (l) (120 kW) at 1,900 rpm
<b>Model</b>	
Stage V / Tier 4 Final	D924 - FPT motor designed for Liebherr
Stage IIIA (compliant)	Cummins QSB4.5
<b>Type</b>	4 cylinder in-line
Bore / Stroke	4.1 / 5.2 in (FPT) 4.2 / 4.9 in (Cummins)
Displacement	274.6 in <sup>3</sup>
<b>Engine operation</b>	4-stroke diesel Common-Rail Turbo-charged and after-cooled Reduced emissions
<b>Air cleaner</b>	Dry-type air cleaner with pre-cleaner, primary and safety elements
<b>Engine idling</b>	Sensor controlled
<b>Electrical system</b>	
Voltage	24 V
Batteries	2 x 135 Ah / 12 V
Alternator	Three-phase current 28 V / 140 A (FPT) Three-phase current 28 V / 80 A (Cummins)
<b>Stage V</b>	
Harmful emissions values	According to regulation (EU) 2016/1628
Emission control	Liebherr-SCRT technology
Fuel tank	66 gal
Urea tank	12 gal
<b>Tier 4 Final</b>	
Harmful emissions values	In accordance with 40CFR1039 (EPA) / 13CCR (CARB)
Emission control	Liebherr-SCR technology
Fuel tank	66 gal
Urea tank	12 gal
<b>Stage IIIA (compliant)</b>	
Harmful emissions values	In accordance with ECE-R.96 Power Band I
Fuel tank	66 gal



## Cooling system

<b>Diesel engine</b>	Water-cooled Compact cooling system consisting cooling unit for water, hydraulic oil and charge air with stepless thermostatically controlled fan, fans for radiator cleaning can be completely folded away
----------------------	--



## Hydraulic controls

<b>Power distribution</b>	Via control valves with integrated safety valves, simultaneous and independent actuation of chassis, swing drive and equipment
<b>Servo circuit</b>	
Equipment and swing	With electro-proportional joystick levers
Chassis	Electro-proportional via foot pedal, dedicated control and display unit for rail undercarriage operation
<b>Additional functions</b>	Via switch or electro-proportional foot pedals
<b>Proportional control</b>	Proportionally acting transmitters on the joysticks for additional hydraulic functions



## Hydraulic system

<b>Hydraulic pump</b>	For equipment and travel drive	2 Liebherr axial piston variable displacement pumps (double construction)
Max. flow		2 x 58 gpm
Max. pressure		5,076 psi / PowerLift 5,439 psi
<b>Hydraulic pump regulation and control</b>		Liebherr-Synchron-Comfort-system (LSC) with electronic engine speed sensing regulation, pressure and flow compensation, torque controlled swing drive priority
<b>Hydraulic tank</b>		34 gal
<b>Hydraulic system</b>		max. 90 gal
<b>Hydraulic oil filter</b>		1 main return filter with integrated partial micro filtration (5 µm)
<b>MODE selection</b>		Adjustment of engine and hydraulic performance via a mode pre-selector to match application, e.g. for especially economical and environmentally friendly operation or for maximum digging performance and heavy-duty jobs
S (Sensitive)		Mode for precision work and lifting through very sensitive movements
E (Eco)		Mode for especially economical and environmentally friendly operation
P (Power)		Mode for high performance with low fuel consumption
P+ (Power-Plus)		Mode for highest performance and for very heavy duty applications, suitable for continuous operation
<b>Engine speed and performance setting</b>		Stepless alignment of engine output and hydraulic power via engine speed Tool Control: 20 pre-adjustable pump flows and pressures for add-on attachments



## Swing drive

<b>Drive</b>	Liebherr axial piston motor with integrated brake valve and torque control, Liebherr planetary reduction gear
<b>Swing ring</b>	Liebherr, sealed race ball bearing swing ring, internal teeth
<b>Swing speed</b>	0 - 9.0 rpm stepless
<b>Swing torque</b>	39,828 lbf ft
<b>Holding brake</b>	Wet multi-disc (spring applied, pressure released) Pedal controlled positioning swing brake

## Cab

<b>Double cabin</b>	ROPS safety cab structure (roll-over protection system for complete operator's cab), shock-absorbing suspension, sound damping insulating, electrically unlockable door, two-piece retractable front windscreen, tinted laminated safety glass, separate window shades for the sunroof window and windscreen, roof window and front windscreen wipers, work headlights integrated in the ceiling, ambient lighting for night operations in addition to interior lighting, access lighting outside, operator's door with a sliding window (can be opened on both sides), large stowing and depositing possibilities, 12 V / 24 V electrical connections
<b>Operator's seat Standard</b>	Air cushioned operator's seat with 3D-adjustable armrests, headrest, lap belt, seat heater, manual weight adjustment, adjustable seat cushion inclination and length and mechanical lumbar vertebrae support
<b>Operator's seat Comfort (Option)</b>	In addition to operator's seat standard: lockable horizontal suspension, automatic weight adjustment, adjustable suspension stiffness, pneumatic lumbar vertebrae support and passive seat climatization with active coal
<b>Operator's seat Premium (Option)</b>	In addition to operator's seat comfort: active electronic weight adjustment (automatic readjustment), pneumatic low frequency suspension and active seat climatization with active coal and ventilator
<b>Two-man operation</b>	Ergonomical co-operator's seat with lap belt as well as signal horn and emergency stop
<b>Arm consoles</b>	Joysticks with control consoles and swivel seat, folding left control console
<b>Operation and displays</b>	Large high-resolution operating unit with touchscreen control, self-explanatory, numerous settings, control and monitoring options, e.g. air conditioning control, fuel consumption, machine and attachment parameters as well as safety functions such as load display, load torque limitation, lift and swivel limitation or virtual wall, separate display for rear view and side view monitoring, dedicated control and display unit for rail undercarriage operation with emergency stop function
<b>Air-conditioning</b>	Complete air-conditioning for operator and co-operator, automatic air-conditioning, recirculated air function, fast de-icing and demisting at the press of a button, air vents can be operated via a menu; recirculated air and fresh air filters can be easily replaced and are accessible from the outside; heating-cooling unit, designed for extreme outside temperatures, sensors for solar radiation, inside and outside temperatures

## Undercarriage

<b>Drive</b>	Oversized two speed power shift transmission with additional creeper speed, Liebherr axial piston motor with functional brake valve on both sides
<b>Pulling force</b>	26,300 lbf
<b>Travel speed</b>	0 - 2.2 mph stepless (creeper speed off-road) 0 - 4.3 mph stepless (off-road) 0 - 8.1 mph stepless (creeper speed on-road) 0 - 12.4 mph stepless (road travel) 0 - max. 15.5 or 18.6 mph Speeder (option)
<b>Driving operation</b>	Automotive driving using accelerator pedal, cruise control function: storage of variable accelerator pedal positions, both off-road, on-road and on-rail
<b>Axles</b>	Manual or automatic hydraulically controlled front axle oscillation lock
Option	Axle with wheel head width 6'11" and differential lock 100%
<b>Service brake</b>	Two circuit travel brake system with accumulator; road axle wet and backlash-free disc brake; rail wheels with drum brake
<b>Holding brake</b>	Wet multi-disc (spring applied, pressure released)
<b>Wagon braking system</b>	1 circuit compressed air brake for railway wagon
Option	2 circuit compressed air brake for trailer 2 circuit hydraulic brake for trailer
<b>Rail guide</b>	Standard gauge 4'8"
Option	Width gauge, narrow gauge type friction drive
<b>Stabilization</b>	Without outriggers
Option	Rear + front outriggers

## Equipment

<b>Type</b>	High-strength steel plates at highly-stressed points for the toughest requirements. Complex and stable mountings of equipment and cylinders
<b>Hydraulic cylinders</b>	Liebherr cylinders with special sealing and guide system and, depending on cylinder type, shock absorption
<b>Bearings</b>	Sealed, low maintenance

## Complete machine

<b>Lubrication</b>	Liebherr central lubrication system for uppercarriage and equipment, automatically
<b>Noise emission</b>	
ISO 6396	70 dB(A) = $L_{pA}$ (inside cab)
2000/14/EC	101 dB(A) = $L_{WA}$ (surround noise)



# Dimensions

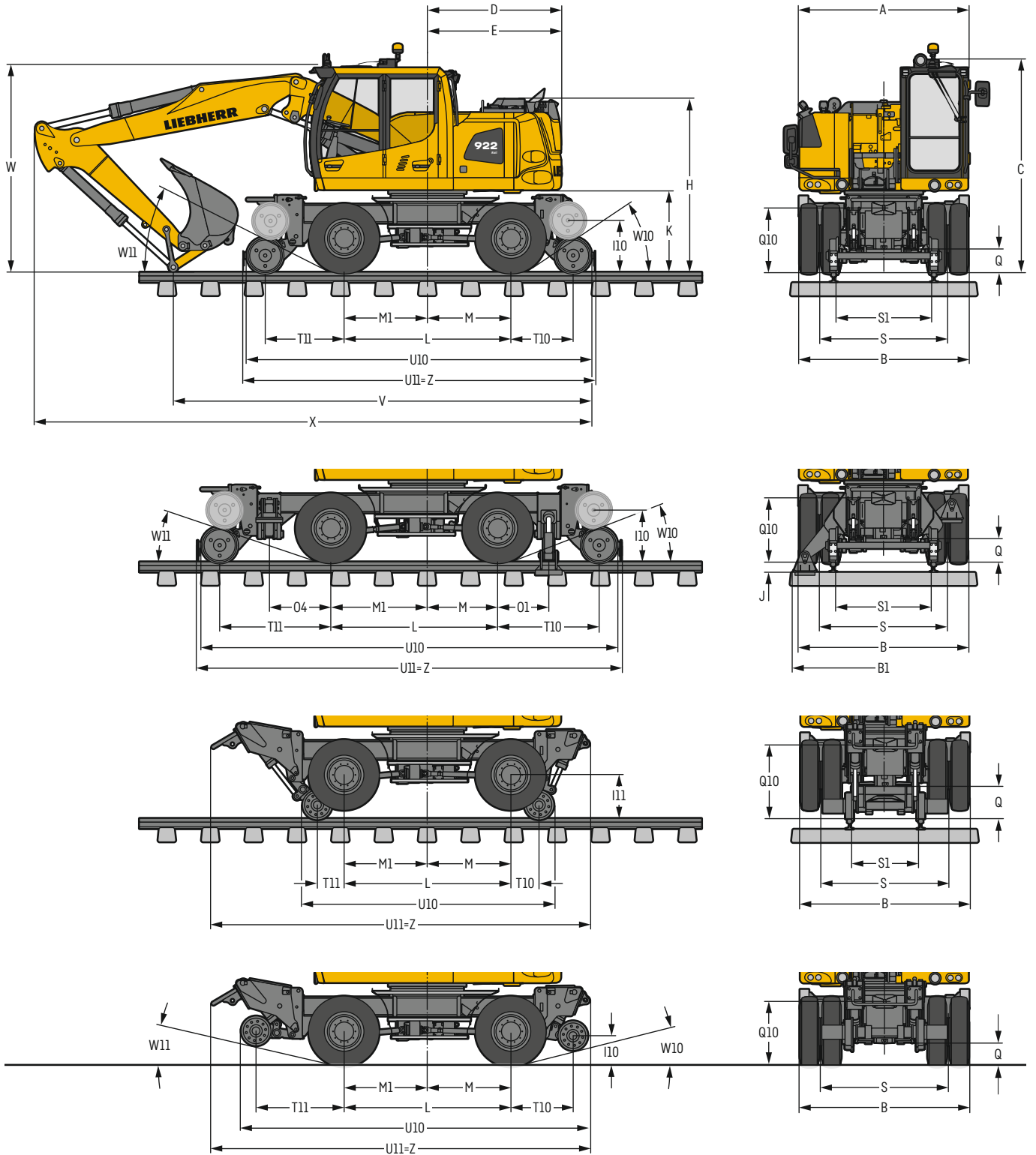

	without outriggers (Asym. / Sym. Rail)	Rear + front outriggers	Narrow gauge (Asym. / Sym. Rail) rail	Narrow gauge (Asym. / Sym. Rail) road
	ft in	ft in	ft in	ft in
A	8' 3"	8' 3"	8' 3"	8'3"
B	8' 4"	8' 4"	8' 4"	8'4"
B1	-	8'10"	-	-
C*	10' 5"	10' 5"	10'11"	10'5"
D	6' 7"	6' 7"	6' 7"	6'7"
E	6' 7"	6' 7"	6' 7"	6'7"
H	8' 6"	8' 6"	9'	8'6"
I10	2' 7"	2' 7"	-	1'5"
I11	-	-	2' 2"	-
J	-	6"	-	-
K	4' 1"	4' 1"	4' 6"	4'1"
L	8' 2"	8' 2"	8' 2"	8'2"
M	3'5" / 4'1"***	3' 5"	3'5" / 4'1"***	3'5" / 4'1"***
M1	4'9" / 4'1"***	4' 9"	4'9" / 4'1"***	4'9" / 4'1"***
O1	-	2' 6"	-	-
O4	-	3'	-	-
Q	7"	7"	5"	1'2"
Q10	3' 2"	3' 2"	3' 8"	3'2"
S	6' 3"	6' 3"	6' 3"	6'3"
S1	4' 8"	4' 8"	3' 3"	-
T10	3' 1"	5'	1' 5"	3'1"
T11	3'10"	5' 6"	1' 4"	4'4"
U10	17'	20' 7"	12' 5"	17'1"
U11	17' 5"	21'	18' 7"	18'7"
W10	33.8°	20.7°	-	15.2°
W11	26.5°	18.8°	-	13.7°
Z	17' 5"	21'	18' 7"	18'7"

\* without signal light DB and amber beacon; can be removed for transport

\*\* Symmetric Rail

E = Tail radius

Tires 10.00-20

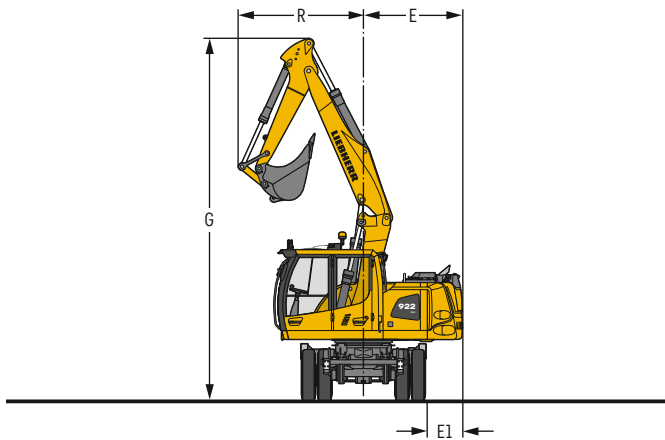

	Stick	Two-piece boom 16'7"		
		without outriggers (Asymmetric Rail)	without outriggers (Symmetric Rail)	Rear + front outriggers
	ft in	ft in	ft in	ft in
V	6'1"	20' 8"	21' 4"	24' 5"
	6'9"	19'10"	20' 6"	23' 7"
	7'5"	21' 6"	20'	23' 2"
W	6'1"	9'10"	9'10"	9'10"
	6'9"	10'	10'	10*
	7'5"	10' 2"	10' 2"	10' 2"
X	6'1"	27' 3"	27'11"	31*
	6'9"	26' 9"	27' 5"	30' 6"
	7'5"	26' 9"	27' 5"	30' 8"

	Stick	Offset two-piece boom 16'5"		
		without outriggers (Asymmetric Rail)	without outriggers (Symmetric Rail)	Rear + front outriggers
	ft in	ft in	ft in	ft in
V	6'1"	22' 2"	22'10"	24'1"
	6'9"	20'10"	21' 6"	24'7"
	7'5"	21'10"	20' 2"	23'5"
W	6'1"	10' 4"	10' 4"	10'4"
	6'9"	10' 4"	10' 4"	10'4"
	7'5"	10' 4"	10' 4"	10'4"
X	6'1"	27' 3"	27'11"	29'2"
	6'9"	26' 9"	27' 5"	30'6"
	7'5"	28'10"	27' 5"	30'6"

Dimensions are with equipment over steering axle

\* Equipment over digging axle for shorter transport dimensions

Boom	Stick ft in	G ft in	R ft in	E ft in	E1 ft in
Two-piece boom 16'7"	6'1"	24'3"	8'5"	6'7"	2'5"
Two-piece boom 16'7"	6'9"	24'3"	8'5"	6'7"	2'5"
Two-piece boom 16'7"	7'5"	24'3"	8'5"	6'7"	2'5"



# Ditch cleaning bucket

with two-piece boom 16'7"

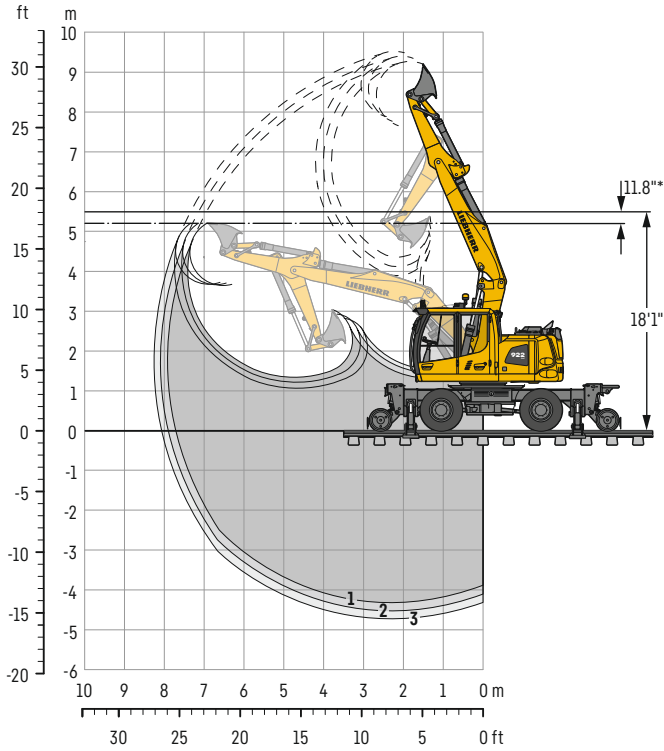

\* Safety distance to overhead wires

## Digging envelope

		1	2	3
Stick length	ft in	6' 1"	6' 9"	7' 5"
Max. digging depth	ft in	14' 3"	14' 11"	15' 7"
Max. reach at ground level	ft in	25' 3"	25' 11"	26' 5"
Max. dumping height	ft in	25' 1"	25' 5"	25' 9"
Max. dumping height under overhead wires	ft in	11' 11"	12'	12'
Max. teeth height	ft in	30' 4"	30' 10"	31' 2"
Min. equipment radius	ft in	8' 5"	8' 5"	8' 5"

## Digging forces

		1	2	3
Max. digging force (ISO 6015)	lbf	24,864	22,975	21,402
	lb	24,910	22,930	21,390
Max. breakout force (ISO 6015)	lbf	22,773	22,773	22,773
	lb	22,710	22,710	22,710

Max. breakout force with ripper bucket 30,259 lbf (30,200 lb)

## Operating weight

The operating weight includes the basic machine with 8 tires plus intermediate rings, two-piece boom 16'7", stick 7'5" and ditch cleaning bucket 78.7" / 0.85 yd<sup>3</sup>.

Undercarriage versions	Weight (lb)
A 922 Rail Litronic without outriggers (Asymmetric Rail)	45,000
A 922 Rail Litronic without outriggers (Symmetric Rail)	45,000
A 922 Rail Litronic with rear + front outriggers	48,700

## Ditch cleaning buckets Machine stability per ISO 10567\* (75% of tipping capacity)

Cutting width ft in	Capacity ISO 7451 <sup>1)</sup> yd <sup>3</sup>	Weight lb	without outriggers									Rear + front outriggers												
			on rail			on tires			on rail			on tires			down			Narrow gauge 3'3"						
			Stick length (ft in)			Stick length (ft in)			Stick length (ft in)			Stick length (ft in)			Stick length (ft in)			Stick length (ft in)			Stick length (ft in)			
6'1"	6'9"	7'5"	6'1"	6'9"	7'5"	6'1"	6'9"	7'5"	6'1"	6'9"	7'5"	6'1"	6'9"	7'5"	6'1"	6'9"	7'5"	6'1"	6'9"	7'5"	6'1"	6'9"	7'5"	
5' 3" <sup>1)</sup>	0.65	728	■	■	■	■	■	■	■	■	■	■	■	■	■	■	■	■	■	■	■	■	■	■
5' 11" <sup>1)</sup>	0.75	794	■	■	■	■	■	■	■	■	■	■	■	■	■	■	■	■	■	■	■	■	■	■
6' 7" <sup>1)</sup>	0.85	860	■	■	■	■	■	■	■	■	■	■	■	■	■	■	■	■	■	■	■	■	■	■
5' 3" <sup>2)</sup>	1.05	1,689	△	△	-	■	■	■	■	■	■	■	■	■	■	■	■	■	△	△	△	■	■	■
6' 7" <sup>2)</sup>	0.92	1,788	△	△	△	■	■	■	■	■	■	■	■	■	■	■	■	■	-	-	-	■	■	■

\* Indicated loads are based on ISO 10567 and do not exceed 75% of tipping or 87% of hydraulic capacity, max. stick length without quick coupler, lifted 360° on firm with blocked oscillating axle

<sup>1)</sup> comparable with SAE (heaped)

<sup>2)</sup> with 2 x 50° rotator

Max. material weight ■ = ≤ 3,034 lb/yd<sup>3</sup>, ■ = ≤ 2,528 lb/yd<sup>3</sup>, △ = ≤ 2,023 lb/yd<sup>3</sup>, - = not authorized

# Lift capacities

with two-piece boom 16'7" (without outriggers)

## Stick 6'1"

ft	Undercarriage	10 ft		15 ft		20 ft		ft in
25	on rail	14,7	18,9*			10,2	13,5*	12' 5"
	on tires	18,9*	18,9*			13,5*	13,5*	
20	on rail	14,9	17,0*	8,1	15,0*	5,6	10,0*	18' 2"
	on tires	17,0*	17,0*	10,8	15,0*	7,6	10,0*	
15	on rail	14,4	22,2*	8,2	16,1*	4,9	13,4*	21' 4"
	on tires	19,4	22,2*	10,9	16,0	6,6	10,1	
10	on rail	13,9	22,3*	8,1	18,2*	4,9	13,9*	22'10"
	on tires	18,8	22,3*	10,8	15,8	6,6	10,1	
5	on rail	13,7	27,1*	7,8	19,4*	4,7	14,2*	23' 2"
	on tires	18,7	27,1*	10,5	15,7	6,5	9,9	
0	on rail	12,7	30,5*	7,4	19,5*	4,5	14,3*	22' 6"
	on tires	17,9	29,9	10,0	15,8	6,2	9,7	
- 5	on rail	12,2	31,2*	6,8	19,8*	4,3	10,7*	20' 6"
	on tires	17,3	30,8	9,4	15,1	6,0	9,5	
-10	on rail	11,9	25,1*			7,0	12,7*	14' 5"
	on tires	17,0	25,1*			9,7	12,7*	

## Stick 6'9"

ft	Undercarriage	10 ft		15 ft		20 ft		ft in
25	on rail	15,0	17,5*			9,1	11,0*	13' 6"
	on tires	17,5*	17,5*			11,0*	11,0*	
20	on rail			8,2	14,6*	5,4	8,6*	18'11"
	on tires			10,9	14,6*	7,3	8,6*	
15	on rail	14,5	21,3*	8,3	15,7*	5,0	13,2*	21'11"
	on tires	19,5	21,3*	10,9	15,7*	6,7	10,3	
10	on rail	13,9	23,3*	8,1	17,9*	5,0	13,8*	23' 5"
	on tires	18,8	23,3*	10,8	15,8	6,7	10,2	
5	on rail	13,7	27,1*	7,9	19,3*	4,8	14,2*	23'10"
	on tires	18,6	27,1*	10,6	15,7	6,6	10,0	
0	on rail	12,8	30,3*	7,4	19,5*	4,6	14,4*	23' 1"
	on tires	18,0	29,9	10,1	15,8	6,3	9,7	
- 5	on rail	12,3	31,0*	6,9	20,0*	4,3	12,0*	21' 1"
	on tires	17,4	30,8	9,5	15,2	6,1	9,5	
-10	on rail	11,9	27,2*	6,6	13,6*	6,0	11,3*	16'
	on tires	17,0	27,2*	9,2	13,6*	8,4	11,3*	

## Stick 7'5"

ft	Undercarriage	10 ft		15 ft		20 ft		ft in
25	on rail					8,2	9,3*	14' 6"
	on tires					9,3*	9,3*	
20	on rail			8,3	14,1*	5,1	7,5*	19' 7"
	on tires			11,0	14,1*	6,9	7,5*	
15	on rail	14,5	18,1*	8,3	15,3*	5,1	12,9*	22' 6"
	on tires	18,1*	18,1*	10,9	15,3*	6,8	10,3	
10	on rail	13,9	24,0*	8,1	17,5*	5,1	13,5*	24'
	on tires	18,8	24,0*	10,7	15,8	6,8	10,3	
5	on rail	13,7	27,1*	8,0	19,1*	4,9	14,1*	24' 5"
	on tires	18,6	27,1*	10,6	15,6	6,6	10,1	
0	on rail	12,9	30,1*	7,4	19,4*	4,6	14,3*	23' 8"
	on tires	18,0	29,7	10,1	15,9	6,3	9,8	
- 5	on rail	12,2	30,8*	6,9	19,9*	4,3	12,9*	21'10"
	on tires	17,3	30,5	9,5	15,2	6,0	9,5	
-10	on rail	11,9	28,8*	6,6	15,4*	5,3	10,2*	17' 4"
	on tires	17,0	28,8*	9,1	14,8	7,4	10,2*	

Height Can be slewed through 360° In longitudinal position of undercarriage Max. reach \* Limited by hydr. capacity

The lift capacities are stated in lb x 1,000 with PowerLift of 5,439 psi at the stick end without attachment. This applies to a firm flat substrate with a closed steering axle. These capacities can be slewed through 360° with the undercarriage in the transverse position. Capacities in the longitudinal position of the undercarriage (+/- 15°) are specified over the steering axle with the stabilizers raised. The values apply when the adjusting cylinder is in the optimal position. Indicated loads based on the ISO 10567 standard and do not exceed 75% of tipping or 87% of hydraulic capacity, or are limited by the permissible load of the load lift hook.

Please note that the stability will be reduced by approx. 20% in case of a 3.9" cant and 40% in case of a 7.9" cant.



# Lift capacities

with two-piece boom 16'7" (without outriggers, heavy counterweight)

## Stick 6'1"

ft	Undercarriage	10 ft		15 ft		20 ft		ft in
25	on rail	15,7	18,9*			11,0	13,5*	12' 5"
	on tires	18,9*	18,9*			13,5*	13,5*	
20	on rail	15,9	17,0*	8,7	15,0*		6,1	18' 2"
	on tires	17,0*	17,0*	11,4	15,0*		8,2	
15	on rail	15,3	22,2*	8,8	16,1*	5,3	13,4*	21' 4"
	on tires	20,4	22,2*	11,5	16,1*	7,1	10,8	
10	on rail	14,8	22,3*	8,7	18,2*	5,3	13,9*	22'10"
	on tires	19,8	22,3*	11,4	16,5	7,1	10,7	
5	on rail	14,7	27,1*	8,4	19,4*	5,2	14,2*	23' 2"
	on tires	19,7	27,1*	11,2	16,5	6,9	10,6	
0	on rail	13,7	30,5*	8,0	19,5*	4,9	14,3*	22' 6"
	on tires	19,0	30,5*	10,7	16,7	6,7	10,3	
- 5	on rail	13,2	31,2*	7,4	19,8*	4,8	10,7*	20' 6"
	on tires	18,5	31,2*	10,1	16,0	6,5	10,1	
-10	on rail	12,9	25,1*				7,6	14' 5"
	on tires	18,2	25,1*				10,4	

## Stick 6'9"

ft	Undercarriage	10 ft		15 ft		20 ft		ft in
25	on rail	15,9	17,5*					13' 6"
	on tires	17,5*	17,5*					
20	on rail			8,8	14,6*			18'11"
	on tires			11,6	14,6*			
15	on rail	15,4	21,3*	8,8	15,7*	5,4	13,2*	21'11"
	on tires	20,5	21,3*	11,5	15,7*	7,2	10,9	
10	on rail	14,9	23,3*	8,7	17,9*	5,4	13,8*	23' 5"
	on tires	19,8	23,3*	11,4	16,6	7,2	10,9	
5	on rail	14,7	27,1*	8,5	19,3*	5,2	14,2*	23'10"
	on tires	19,7	27,1*	11,3	16,5	7,0	10,7	
0	on rail	13,8	30,3*	8,0	19,5*	5,0	14,4*	23' 1"
	on tires	19,2	30,3*	10,7	16,8	6,8	10,4	
- 5	on rail	13,2	31,0*	7,5	20,0*	4,8	12,0*	21' 1"
	on tires	18,5	31,0*	10,2	16,1	6,5	10,1	
-10	on rail	12,9	27,2*	7,2	13,6*			16'
	on tires	18,2	27,2*	9,9	13,6*			

## Stick 7'5"

ft	Undercarriage	10 ft		15 ft		20 ft		ft in
25	on rail					8,9	9,3*	14' 6"
	on tires					9,3*	9,3*	
20	on rail			8,9	14,1*		5,5	19' 7"
	on tires			11,7	14,1*		7,4	
15	on rail	15,5	18,1*	8,8	15,3*	5,5	12,9*	22' 6"
	on tires	18,1*	18,1*	11,5	15,3*	7,3	10,9	
10	on rail	14,9	24,0*	8,7	17,5*	5,5	13,5*	24'
	on tires	19,8	24,0*	11,3	16,5	7,3	10,9	
5	on rail	14,6	27,1*	8,6	19,1*	5,3	14,1*	24' 5"
	on tires	19,6	27,1*	11,3	16,4	7,1	10,7	
0	on rail	13,8	30,1*	8,0	19,4*	5,0	14,3*	23' 8"
	on tires	19,2	30,1*	10,8	16,6	6,8	10,4	
- 5	on rail	13,2	30,8*	7,5	19,9*	4,7	12,9*	21'10"
	on tires	18,5	30,8*	10,2	16,1	6,5	10,1	
-10	on rail	12,9	28,8*	7,1	15,4*			17' 4"
	on tires	18,2	28,8*	9,8	15,4*			

Height Can be slewed through 360° In longitudinal position of undercarriage Max. reach \* Limited by hydr. capacity

The lift capacities are stated in lb x 1,000 with PowerLift of 5,439 psi at the stick end without attachment. This applies to a firm flat substrate with a closed steering axle. These capacities can be slewed through 360° with the undercarriage in the transverse position. Capacities in the longitudinal position of the undercarriage (+/- 15°) are specified over the steering axle with the stabilizers raised. The values apply when the adjusting cylinder is in the optimal position. Indicated loads based on the ISO 10567 standard and do not exceed 75% of tipping or 87% of hydraulic capacity, or are limited by the permissible load of the load lift hook.

Please note that the stability will be reduced by approx. 20% in case of a 3.9° cant and 40% in case of a 7.9° cant.

# Lift capacities

with two-piece boom 16'7" (rear + front outriggers)

## Stick 6'1"

ft	Undercarriage	10 ft		15 ft		20 ft		ft in	
25	on rail	15,7	18,9*			10,9	13,5*		
	on tires	18,9*	18,9*			13,5*	13,5*	12' 5"	
	rear + front outriggers down	18,9*	18,9*			13,5*	13,5*		
20	on rail	15,9	17,0*	8,7	15,0*		6,1	10,0*	
	on tires	17,0*	17,0*	11,6	15,0*		8,3	10,0*	
	rear + front outriggers down	17,0*	17,0*	14,5	15,0*		10,0*	10,0*	
15	on rail	15,3	22,2*	8,8	16,1*	5,3	13,4*	4,7	8,8*
	on tires	20,6	22,2*	11,6	16,1*	7,2	10,9	6,4	8,8*
	rear + front outriggers down	22,2*	22,2*	14,3	16,1*	9,1	13,4*	8,2	8,8*
10	on rail	14,8	22,3*	8,7	18,2*	5,3	13,9*	4,1	8,5*
	on tires	20,0	22,3*	11,5	16,8	7,2	10,9	5,6	8,5*
	rear + front outriggers down	22,3*	22,3*	14,1	18,2*	9,1	13,9*	7,2	8,5*
5	on rail	14,7	27,1*	8,4	19,4*	5,1	14,2*	3,9	8,6*
	on tires	19,9	27,1*	11,3	16,7	7,0	10,8	5,4	8,3
	rear + front outriggers down	25,3	27,1*	14,1	19,4*	8,9	14,2*	6,9	8,6*
0	on rail	13,6	30,5*	7,9	19,5*	4,9	14,3*	4,0	9,3*
	on tires	19,3	30,5*	10,8	17,0	6,8	10,5	5,6	8,7
	rear + front outriggers down	25,7	30,5*	13,8	19,5*	8,7	14,3*	7,2	9,3*
- 5	on rail	13,2	31,2*	7,4	19,8*	4,7	10,7*	4,6	9,4*
	on tires	18,8	31,2*	10,2	16,3	6,6	10,3	6,4	9,4*
	rear + front outriggers down	25,1	31,2*	13,2	19,8*	8,5	10,7*	8,2	9,4*
-10	on rail	12,9	25,1*					7,6	12,7*
	on tires	18,4	25,1*					10,6	12,7*
	rear + front outriggers down	24,8	25,1*					12,7*	12,7*

## Stick 6'9"

ft	Undercarriage	10 ft		15 ft		20 ft		ft in	
25	on rail	15,9	17,5*					9,8	11,0*
	on tires	17,5*	17,5*					11,0*	11,0*
	rear + front outriggers down	17,5*	17,5*					11,0*	11,0*
20	on rail			8,8	14,6*			5,8	8,6*
	on tires			11,7	14,6*			7,9	8,6*
	rear + front outriggers down			14,6	14,6*			8,6*	8,6*
15	on rail	15,4	21,3*	8,8	15,7*	5,4	13,2*	4,5	7,8*
	on tires	20,7	21,3*	11,7	15,7*	7,3	11,1	6,2	7,8*
	rear + front outriggers down	21,3*	21,3*	14,4	15,7*	9,2	13,2*	7,8*	7,8*
10	on rail	14,9	23,3*	8,7	17,9*	5,4	13,8*	3,9	7,5*
	on tires	20,0	23,3*	11,5	16,8	7,3	11,0	5,5	7,5*
	rear + front outriggers down	23,3*	23,3*	14,1	17,9*	9,2	13,8*	7,0	7,5*
5	on rail	14,7	27,1*	8,5	19,3*	5,2	14,2*	3,8	7,7*
	on tires	19,9	27,1*	11,4	16,7	7,1	10,8	5,2	7,7*
	rear + front outriggers down	25,2	27,1*	14,1	19,3*	9,0	14,2*	6,7	7,7*
0	on rail	13,8	30,3*	8,0	19,5*	5,0	14,4*	3,9	8,4*
	on tires	19,4	30,3*	10,9	17,0	6,9	10,6	5,4	8,4
	rear + front outriggers down	25,6	30,3*	13,9	19,5*	8,8	14,4*	7,0	8,4*
- 5	on rail	13,2	31,0*	7,5	20,0*	4,8	12,0*	4,4	9,6*
	on tires	18,8	31,0*	10,3	16,4	6,6	10,3	6,1	9,5
	rear + front outriggers down	25,2	31,0*	13,3	20,0*	8,5	12,0*	7,8	9,6*
-10	on rail	12,9	27,2*	7,2	13,6*			6,6	11,3*
	on tires	18,4	27,2*	10,0	13,6*			9,1	11,3*
	rear + front outriggers down	24,8	27,2*	13,0	13,6*			11,3*	11,3*

## Stick 7'5"

ft	Undercarriage	10 ft		15 ft		20 ft		ft in	
25	on rail							8,8	9,3*
	on tires							9,3*	9,3*
	rear + front outriggers down							9,3*	9,3*
20	on rail			8,9	14,1*			5,5	7,5*
	on tires			11,8	14,1*			7,5	7,5*
	rear + front outriggers down			14,1*	14,1*			7,5*	7,5*
15	on rail	15,5	18,1*	8,8	15,3*	5,5	12,9*	4,3	6,9*
	on tires	18,1*	18,1*	11,7	15,3*	7,4	11,1	5,9	6,9*
	rear + front outriggers down	18,1*	18,1*	14,4	15,3*	9,3	12,9*	6,9*	6,9*
10	on rail	14,9	24,0*	8,7	17,5*	5,5	13,5*	3,8	6,8*
	on tires	20,0	24,0*	11,5	16,8	7,4	11,1	5,3	6,8*
	rear + front outriggers down	24,0*	24,0*	14,1	17,5*	9,3	13,5*	6,7	6,8*
5	on rail	14,6	27,1*	8,6	19,1*	5,3	14,1*	3,6	7,0*
	on tires	19,8	27,1*	11,4	16,6	7,2	10,9	5,0	7,0*
	rear + front outriggers down	25,1	27,1*	14,0	19,1*	9,1	14,1*	6,5	7,0*
0	on rail	13,8	30,1*	8,0	19,4*	5,0	14,3*	3,7	7,6*
	on tires	19,5	30,1*	10,9	16,9	6,9	10,6	5,2	7,6*
	rear + front outriggers down	25,5	30,1*	13,9	19,4*	8,8	14,3*	6,7	7,6*
- 5	on rail	13,2	30,8*	7,5	19,9*	4,7	12,9*	4,1	9,0*
	on tires	18,8	30,8*	10,4	16,4	6,6	10,3	5,8	9,0*
	rear + front outriggers down	25,1	30,8*	13,3	19,9*	8,5	12,9*	7,5	9,0*
-10	on rail	12,9	28,8*	7,1	15,4*			5,8	10,2*
	on tires	18,4	28,8*	10,0	15,4*			8,1	10,2*
	rear + front outriggers down	24,7	28,8*	12,9	15,4*			10,2*	10,2*

Height Can be slewed through 360° In longitudinal position of undercarriage Max. reach \* Limited by hydr. capacity

The lift capacities are stated in lb x 1,000 with PowerLift of 5,439 psi at the stick end without attachment. This applies to a firm flat substrate with a closed steering axle. These capacities can be slewed through 360° with the undercarriage in the transverse position. Capacities in the longitudinal position of the undercarriage (+/- 15°) are specified over the steering axle with the stabilizers raised and over the rigid axle with the stabilizers down. The values apply when the adjusting cylinder is in the optimal position. Indicated loads based on the ISO 10567 standard and do not exceed 75% of tipping or 87% of hydraulic capacity, or are limited by the permissible load of the load lift hook.

Please note that the stability will be reduced by approx. 20% in case of a 3.9° cant and 40% in case of a 7.9° cant.



# Lift capacities

with two-piece boom 16'7" (rear + front outriggers, heavy counterweight)

## Stick 6'1"

ft	Undercarriage	10 ft		15 ft		20 ft		ft in
25	on rail	16,7	18,9*			11,7	13,5*	12' 5"
	on tires	18,9*	18,9*			13,5*	13,5*	
	rear + front outriggers down	18,9*	18,9*			13,5*	13,5*	
20	on rail	16,8	17,0*	9,2	15,0*	6,6	10,0*	18' 2"
	on tires	17,0*	17,0*	12,3	15,0*	8,8	10,0*	
	rear + front outriggers down	17,0*	17,0*	15,0*	15,0*	10,0*	10,0*	
15	on rail	16,3	22,2*	9,4	16,1*	5,7	13,4*	21' 4"
	on tires	21,6	22,2*	12,2	16,1*	7,7	11,6	
	rear + front outriggers down	22,2*	22,2*	15,0	16,1*	9,6	13,4*	
10	on rail	15,8	22,3*	9,3	18,2*	5,7	13,9*	22'10"
	on tires	21,0	22,3*	12,1	17,5	7,7	11,6	
	rear + front outriggers down	22,3*	22,3*	14,8	18,2*	9,7	13,9*	
5	on rail	15,7	27,1*	9,0	19,4*	5,6	14,2*	23' 2"
	on tires	20,9	27,1*	12,0	17,4	7,5	11,4	
	rear + front outriggers down	26,4	27,1*	14,8	19,4*	9,5	14,2*	
0	on rail	14,6	30,5*	8,5	19,5*	5,3	14,3*	22' 6"
	on tires	20,4	30,5*	11,5	17,9	7,3	11,1	
	rear + front outriggers down	26,8	30,5*	14,6	19,5*	9,2	14,3*	
- 5	on rail	14,2	31,2*	8,0	19,8*	5,2	10,7*	20' 6"
	on tires	19,9	31,2*	10,9	17,2	7,1	10,7*	
	rear + front outriggers down	26,6	31,2*	14,0	19,8*	9,0	10,7*	
-10	on rail	13,9	25,1*			8,2	12,7*	14' 5"
	on tires	19,6	25,1*			11,3	12,7*	
	rear + front outriggers down	25,1*	25,1*			12,7*	12,7*	

## Stick 6'9"

ft	Undercarriage	10 ft		15 ft		20 ft		ft in
25	on rail	16,9	17,5*			10,5	11,0*	13' 6"
	on tires	17,5*	17,5*			11,0*	11,0*	
	rear + front outriggers down	17,5*	17,5*			11,0*	11,0*	
20	on rail			9,4	14,6*	6,3	8,6*	18'11"
	on tires			12,4	14,6*	8,4	8,6*	
	rear + front outriggers down			14,6*	14,6*	8,6*	8,6*	
15	on rail	16,4	21,3*	9,4	15,7*	5,8	13,2*	21'11"
	on tires	21,3*	21,3*	12,3	15,7*	7,8	11,7	
	rear + front outriggers down	21,3*	21,3*	15,1	15,7*	9,8	13,2*	
10	on rail	15,8	23,3*	9,3	17,9*	5,8	13,8*	23' 5"
	on tires	21,0	23,3*	12,1	17,5	7,8	11,7	
	rear + front outriggers down	23,3*	23,3*	14,8	17,9*	9,8	13,8*	
5	on rail	15,7	27,1*	9,1	19,3*	5,7	14,2*	23'10"
	on tires	20,9	27,1*	12,1	17,4	7,6	11,5	
	rear + front outriggers down	26,4	27,1*	14,8	19,3*	9,6	14,2*	
0	on rail	14,7	30,3*	8,6	19,5*	5,4	14,4*	23' 1"
	on tires	20,6	30,3*	11,6	17,7	7,3	11,2	
	rear + front outriggers down	26,7	30,3*	14,7	19,5*	9,3	14,4*	
- 5	on rail	14,2	31,0*	8,1	20,0*	5,2	12,0*	21' 1"
	on tires	20,0	31,0*	11,0	17,3	7,1	10,9	
	rear + front outriggers down	26,6	31,0*	14,1	20,0*	9,1	12,0*	
-10	on rail	13,9	27,2*	7,8	13,6*	7,1	11,3*	16'
	on tires	19,6	27,2*	10,7	13,6*	9,8	11,3*	
	rear + front outriggers down	26,2	27,2*	13,6*	13,6*	11,3*	11,3*	

## Stick 7'5"

ft	Undercarriage	10 ft		15 ft		20 ft		ft in
25	on rail					9,3*	9,3*	14' 6"
	on tires					9,3*	9,3*	
	rear + front outriggers down					9,3*	9,3*	
20	on rail			9,5	14,1*	5,9	7,5*	19' 7"
	on tires			12,4	14,1*	7,5*	7,5*	
	rear + front outriggers down			14,1*	14,1*	7,5*	7,5*	
15	on rail	16,4	18,1*	9,4	15,3*	5,9	12,9*	22' 6"
	on tires	18,1*	18,1*	12,3	15,3*	7,9	11,8	
	rear + front outriggers down	18,1*	18,1*	15,1	15,3*	9,8	12,9*	
10	on rail	15,8	24,0*	9,3	17,5*	5,9	13,5*	24'
	on tires	21,0	24,0*	12,1	17,5*	7,9	11,7	
	rear + front outriggers down	24,0*	24,0*	14,8	17,5*	9,8	13,5*	
5	on rail	15,6	27,1*	9,1	19,1*	5,7	14,1*	24' 5"
	on tires	20,8	27,1*	12,0	17,4	7,7	11,5	
	rear + front outriggers down	26,3	27,1*	14,7	19,1*	9,6	14,1*	
0	on rail	14,8	30,1*	8,6	19,4*	5,4	14,3*	23' 8"
	on tires	20,6	30,1*	11,6	17,6	7,4	11,2	
	rear + front outriggers down	26,6	30,1*	14,7	19,4*	9,3	14,3*	
- 5	on rail	14,2	30,8*	8,1	19,9*	5,2	12,9*	21'10"
	on tires	19,9	30,8*	11,0	17,3	7,1	10,9	
	rear + front outriggers down	26,6	30,8*	14,1	19,9*	9,0	12,9*	
-10	on rail	13,8	28,8*	7,7	15,4*	6,3	10,2*	17' 4"
	on tires	19,6	28,8*	10,6	15,4*	8,7	10,2*	
	rear + front outriggers down	26,2	28,8*	13,7	15,4*	10,2*	10,2*	

Height Can be slewed through 360° In longitudinal position of undercarriage Max. reach \* Limited by hydr. capacity

The lift capacities are stated in lb x 1,000 with PowerLift of 5,439 psi at the stick end without attachment. This applies to a firm flat substrate with a closed steering axle. These capacities can be slewed through 360° with the undercarriage in the transverse position. Capacities in the longitudinal position of the undercarriage (+/- 15°) are specified over the steering axle with the stabilizers raised and over the rigid axle with the stabilizers down. The values apply when the adjusting cylinder is in the optimal position. Indicated loads based on the ISO 10567 standard and do not exceed 75% of tipping or 87% of hydraulic capacity, or are limited by the permissible load of the load lift hook.

Please note that the stability will be reduced by approx. 20% in case of a 3.9° cant and 40% in case of a 7.9° cant.

# Lift capacities

with two-piece boom 16'7" (heavy counterweight), narrow gauge 3'3"

## Stick 6'1"

ft	Undercarriage	10 ft		15 ft		20 ft		ft in
25	on rail	11,6	18,6*			7,3	12,9*	13' 2"
	on tires	18,9*	18,9*			13,5*	13,5*	
20	on rail	11,6	17,0*	6,4	15,1*	4,3	9,8*	18' 7"
	on tires	17,0*	17,0*	11,4	15,0*	8,2	10,0*	
15	on rail	11,1	22,5*	6,6	16,3*	3,8	12,1	21' 6"
	on tires	20,4	22,2*	11,5	16,1*	7,1	10,8	
10	on rail	10,7	22,7*	6,5	18,1	3,8	12,0	22'11"
	on tires	19,8	22,3*	11,4	16,5	7,1	10,7	
5	on rail	10,5	27,4*	6,1	18,0	3,6	11,8	23' 2"
	on tires	19,7	27,1*	11,2	16,5	6,9	10,6	
0	on rail	9,6	30,5*	5,7	18,4	3,4	11,6	22' 4"
	on tires	19,0	30,5*	10,7	16,7	6,7	10,3	
- 5	on rail	9,2	31,3*	5,2	17,9	3,3	9,8*	20' 2"
	on tires	18,5	31,2*	10,1	16,0	6,5	10,1	
-10	on rail	8,9	23,2*			6,1	14,1*	13' 2"
	on tires	18,2	25,1*			10,4	12,7*	

## Stick 6'9"

ft	Undercarriage	10 ft		15 ft		20 ft		ft in
25	on rail	11,8	17,3*					14' 2"
	on tires	17,5*	17,5*					
20	on rail	11,7	15,2*	6,6	14,6*			19' 4"
	on tires			11,6	14,6*			
15	on rail	11,2	21,9*	6,6	15,9*	3,9	12,2	22' 1"
	on tires	20,5	21,3*	11,5	15,7*	7,2	10,9	
10	on rail	10,7	23,7*	6,5	18,1*	3,9	12,1	23' 6"
	on tires	19,8	23,3*	11,4	16,6	7,2	10,9	
5	on rail	10,6	27,5*	6,2	18,0	3,7	11,9	23'10"
	on tires	19,7	27,1*	11,3	16,5	7,0	10,7	
0	on rail	9,7	30,5*	5,8	18,3	3,5	11,6	22'11"
	on tires	19,2	30,3*	10,7	16,8	6,8	10,4	
- 5	on rail	9,2	31,1*	5,2	18,0	3,3	11,4*	20'11"
	on tires	18,5	31,0*	10,2	16,1	6,5	10,1	
-10	on rail	8,9	25,7*					15'
	on tires	18,2	27,2*	9,9	13,6*			

## Stick 7'5"

ft	Undercarriage	10 ft		15 ft		20 ft		ft in
25	on rail			6,2	10,0*			15'2"
	on tires					6,1	9,0*	
20	on rail			6,7	14,1*			20'
	on tires			11,7	14,1*	3,8	7,4*	
15	on rail	11,2	20,1*	6,6	15,5*	4,0	12,2	22'8"
	on tires	18,1*	18,1*	11,5	15,3*	7,3	10,9	
10	on rail	10,7	24,3*	6,4	17,7*	4,0	12,1	24'1"
	on tires	19,8	24,0*	11,3	16,5	7,3	10,9	
5	on rail	10,5	27,4*	6,3	17,9	3,8	12,0	24'4"
	on tires	19,6	27,1*	11,3	16,4	7,1	10,7	
0	on rail	9,7	30,2*	5,8	18,1	3,5	11,7	23'6"
	on tires	19,2	30,1*	10,8	16,6	6,8	10,4	
- 5	on rail	9,2	30,9*	5,3	18,0	3,2	11,4	21'6"
	on tires	18,5	30,8*	10,2	16,1	6,5	10,1	
-10	on rail	8,9	27,6*	5,0	14,2*			16'5"
	on tires	18,2	28,8*	9,8	15,4*	4,3	10,8*	

Height Can be slewed through 360° In longitudinal position of undercarriage Max. reach \* Limited by hydr. capacity

The lift capacities are stated in lb x 1,000 with PowerLift of 5,439 psi at the stick end without attachment. This applies to a firm flat substrate with a closed steering axle. These capacities can be slewed through 360° with the undercarriage in the transverse position. Capacities in the longitudinal position of the undercarriage (+/- 15°) are specified over the steering axle with the stabilizers raised. The values apply when the adjusting cylinder is in the optimal position. Indicated loads based on the ISO 10567 standard and do not exceed 75% of tipping or 87% of hydraulic capacity, or are limited by the permissible load of the load lift hook.

Please note that the stability will be reduced by approx. 20% in case of a 3.9° cant and 40% in case of a 7.9° cant.



# Backhoe bucket

with offset two-piece boom 16'5"

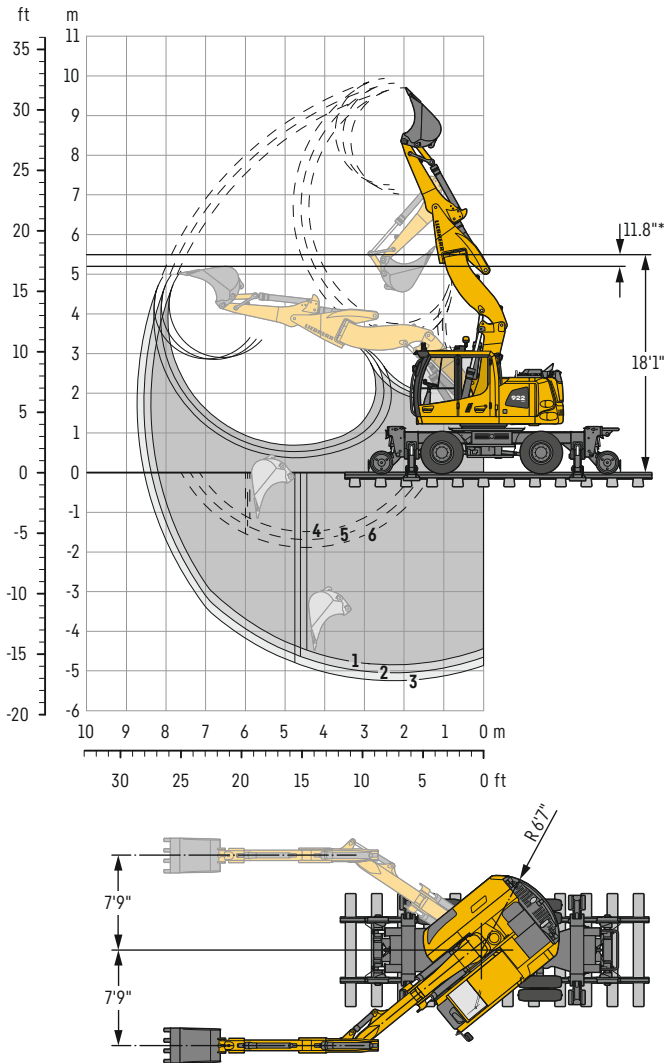

## Digging envelope

		1	2	3
Stick length	ft in	6' 1"	6' 9"	7' 5"
Max. digging depth	ft in	15' 11"	16' 7"	17' 3"
Max. reach at ground level	ft in	26' 11"	27' 7"	28' 1"
Max. dumping height	ft in	23' 2"	23' 5"	23' 9"
Max. dumping height under overhead wires	ft in	9' 4"	9' 4"	9' 4"
Max. teeth height	ft in	31' 10"	32' 2"	32' 8"
Min. equipment radius	ft in	8' 6"	8' 5"	8' 5"

- 1 with stick 6'1"
- 2 with stick 6'9"
- 3 with stick 7'5"
- with set straight boom
- 4 with stick 6'1"
- 5 with stick 6'9"
- 6 with stick 7'5"
- at max. equipment offset with vertical ditch walls

## Digging forces

		1	2	3
Max. digging force (ISO 6015)	lbf	24,864	22,975	21,402
	lb	24,910	22,930	21,390
Max. breakout force (ISO 6015)	lbf	22,773	22,773	22,773
	lb	22,710	22,710	22,710

Max. breakout force with ripper bucket 30,259 lbf (30,200 lb)

## Operating weight

The operating weight includes the basic machine with 8 tires plus intermediate rings, offset two-piece boom 16'5", stick 7'5" and bucket 33.5" / 0.78 yd<sup>3</sup>.

Undercarriage versions	Weight (lb)
A 922 Rail Litronic without outriggers (Asymmetric Rail)	46,500
A 922 Rail Litronic without outriggers (Symmetric Rail)	46,500
A 922 Rail Litronic with rear + front outriggers	50,300

\* Safety distance to overhead wires

## Buckets Machine stability per ISO 10567\* (75% of tipping capacity)

Cutting width ft in	Capacity ISO 7451 <sup>1)</sup> yd <sup>3</sup>	Weight lb	without outriggers						on rail			Rear + front outriggers on tires			down		
			on rail			on tires			Stick length (ft in)			Stick length (ft in)			Stick length (ft in)		
			6'1"	6'9"	7'5"	6'1"	6'9"	7'5"	6'1"	6'9"	7'5"	6'1"	6'9"	7'5"	6'1"	6'9"	7'5"
1'4"	0.31	683	■	■	■	■	■	■	■	■	■	■	■	■	■	■	■
2'2"	0.59	767	■	■	■	■	■	■	■	■	■	■	■	■	■	■	■
2'9"	0.78	884	■	■	■	■	■	■	■	■	■	■	■	■	■	■	■
3'5"	1.05	1,058	■	■	■	■	■	■	■	■	■	■	■	■	■	■	■
4'1"	1.24	1,157	△	△	-	■	■	■	△	△	△	■	■	■	■	■	■
			-	-	-	■	■	■	△	△	-	■	■	■	■	■	■

\* Indicated loads are based on ISO 10567 and do not exceed 75% of tipping or 87% of hydraulic capacity, max. stick length without quick coupler, lifted 360° on firm with blocked oscillating axle  
<sup>1)</sup> comparable with SAE (heaped)

Max. material weight ■ = ≤ 3,034 lb/yd<sup>3</sup>, ■ = ≤ 2,528 lb/yd<sup>3</sup>, △ = ≤ 2,023 lb/yd<sup>3</sup>, - = not authorized

# Lift capacities

with offset two-piece boom 16'5" (without outriggers)

## Stick 6'1"

ft	Undercarriage	10 ft		15 ft		20 ft		ft in
25	on rail	14,7	18,4*			10,3	12,4*	12'2"
	on tires	18,4*	18,4*			12,4*	12,4*	
20	on rail	14,9	17,3*	7,8	14,5*		5,4	18'
	on tires	17,3*	17,3*	10,6	14,5*		7,4	
15	on rail	14,2	21,3*	8,1	15,4*	4,5	12,9*	21'1"
	on tires	19,2	21,3*	10,7	15,4*	6,3	9,8	
10	on rail	13,6	21,8*	8,0	17,3*	4,5	13,3*	22'8"
	on tires	18,4	21,8*	10,6	15,4	6,3	9,9	
5	on rail	13,5	26,4*	7,6	18,5*	4,3	13,6*	23'1"
	on tires	18,3	26,4*	10,4	15,4	6,1	9,6	
0	on rail	12,3	29,4*	7,1	18,7*	4,0	13,7*	22'5"
	on tires	17,5	29,0	9,7	15,6	5,8	9,3	
- 5	on rail	11,7	30,3*	6,3	19,2*	3,8	10,1*	20'5"
	on tires	16,9	30,3*	9,0	14,7	5,6	9,1	
-10	on rail	11,3	24,2*				6,4	14'6"
	on tires	16,4	24,2*				9,2	

## Stick 6'9"

ft	Undercarriage	10 ft		15 ft		20 ft		ft in
25	on rail	15,0	17,2*					13' 4"
	on tires	17,2*	17,2*					
20	on rail			8,1	14,0*			18' 8"
	on tires			10,8	14,0*			
15	on rail	14,4	20,5*	8,1	15,1*	4,7	12,6*	21' 8"
	on tires	19,3	20,5*	10,8	15,1*	6,4	10,0	
10	on rail	13,6	22,8*	8,0	17,1*	4,7	13,2*	23' 4"
	on tires	18,5	22,8*	10,6	15,5	6,4	10,0	
5	on rail	13,4	26,5*	7,8	18,4*	4,5	13,6*	23' 8"
	on tires	18,3	26,5*	10,5	15,4	6,2	9,8	
0	on rail	12,4	29,3*	7,1	18,7*	4,1	13,8*	22'11"
	on tires	17,6	28,9	9,8	15,7	5,9	9,4	
- 5	on rail	11,8	30,1*	6,4	19,3*	3,9	11,4*	21'
	on tires	16,9	30,0	9,1	14,8	5,6	9,1	
-10	on rail	11,3	26,4*	6,1	12,9*			16'
	on tires	16,4	26,4*	8,7	12,9*			

## Stick 7'5"

ft	Undercarriage	10 ft		15 ft		20 ft		ft in
25	on rail					8,2	8,6*	14' 4"
	on tires					8,6*	8,6*	
20	on rail			8,2	13,6*			19' 6"
	on tires			10,9	13,6*			
15	on rail	14,4	18,8*	8,1	14,7*	4,8	12,3*	22' 5"
	on tires	18,8*	18,8*	10,8	14,7*	6,5	10,1	
10	on rail	13,7	23,4*	7,9	16,7*	4,8	12,9*	23'11"
	on tires	18,5	23,4*	10,6	15,4	6,5	10,1	
5	on rail	13,4	26,4*	7,8	18,3*	4,5	13,5*	24' 2"
	on tires	18,2	26,4*	10,6	15,3	6,3	9,8	
0	on rail	12,5	29,0*	7,2	18,5*	4,2	13,7*	23' 6"
	on tires	17,7	28,7	9,9	15,7	5,9	9,4	
- 5	on rail	11,7	29,8*	6,5	19,3*	3,9	12,3*	21' 7"
	on tires	16,9	29,7	9,1	14,9	5,6	9,1	
-10	on rail	11,3	28,0*	6,0	14,7*			17' 4"
	on tires	16,4	28,0*	8,6	14,3			

Height Can be slewed through 360° In longitudinal position of undercarriage Max. reach \* Limited by hydr. capacity

The lift capacities are stated in lb x 1,000 with PowerLift of 5,439 psi at the stick end without attachment. This applies to a firm flat substrate with a closed steering axle. These capacities can be slewed through 360° with the undercarriage in the transverse position. Capacities in the longitudinal position of the undercarriage (+/- 15°) are specified over the steering axle with the stabilizers raised. The values apply when the adjusting cylinder is in the optimal position. Indicated loads based on the ISO 10567 standard and do not exceed 75% of tipping or 87% of hydraulic capacity, or are limited by the permissible load of the load lift hook.

Please note that the stability will be reduced by approx. 20% in case of a 3.9° cant and 40% in case of a 7.9° cant.



# Lift capacities

with offset two-piece boom 16'5" (without outriggers, heavy counterweight)

## Stick 6'1"

ft	Undercarriage	10 ft		15 ft		20 ft		ft in
25	on rail	15,7	18,4*			11,0	12,4*	12'2"
	on tires	18,4*	18,4*			12,4*	12,4*	
20	on rail	15,9	17,3*	8,4	14,5*		5,8	18'
	on tires	17,3*	17,3*	11,3	14,5*		7,9	
15	on rail	15,2	21,3*	8,7	15,4*	4,9	12,9*	21'1"
	on tires	20,2	21,3*	11,3	15,4*	6,8	10,5	
10	on rail	14,5	21,8*	8,5	17,3*	4,9	13,3*	22'8"
	on tires	19,4	21,8*	11,2	16,1	6,8	10,5	
5	on rail	14,4	26,4*	8,2	18,5*	4,8	13,6*	23'1"
	on tires	19,3	26,4*	11,0	16,1	6,6	10,3	
0	on rail	13,2	29,4*	7,7	18,7*	4,5	13,7*	22'5"
	on tires	18,7	29,4*	10,4	16,5	6,3	9,9	
- 5	on rail	12,7	30,3*	6,9	19,2*	4,3	10,1*	20'5"
	on tires	18,1	30,3*	9,7	15,6	6,0	9,7	
-10	on rail	12,3	24,2*			7,0	12,0*	14'6"
	on tires	17,6	24,2*			9,9	12,0*	

## Stick 6'9"

ft	Undercarriage	10 ft		15 ft		20 ft		ft in
25	on rail	16,0	17,2*					13' 4"
	on tires	17,2*	17,2*					
20	on rail			8,6	14,0*			18' 8"
	on tires			11,5	14,0*			
15	on rail	15,3	20,5*	8,7	15,1*	5,1	12,6*	21' 8"
	on tires	20,3	20,5*	11,4	15,1*	6,9	10,6	
10	on rail	14,6	22,8*	8,5	17,1*	5,1	13,2*	23' 4"
	on tires	19,4	22,8*	11,2	16,2	6,9	10,6	
5	on rail	14,4	26,5*	8,3	18,4*	4,9	13,6*	23' 8"
	on tires	19,3	26,5*	11,2	16,1	6,7	10,4	
0	on rail	13,4	29,3*	7,7	18,7*	4,5	13,8*	22'11"
	on tires	18,8	29,3*	10,5	16,6	6,4	10,0	
- 5	on rail	12,7	30,1*	7,0	19,3*	4,3	11,4*	21'
	on tires	18,1	30,1*	9,7	15,7	6,1	9,7	
-10	on rail	12,3	26,4*	6,6	12,9*			16'
	on tires	17,6	26,4*	9,4	12,9*			

## Stick 7'5"

ft	Undercarriage	10 ft		15 ft		20 ft		ft in
25	on rail					8,6*	8,6*	14' 4"
	on tires					8,6*	8,6*	
20	on rail			8,8	13,6*			19' 6"
	on tires			11,6	13,6*			
15	on rail	15,4	18,8*	8,7	14,7*	5,2	12,3*	22' 5"
	on tires	18,8*	18,8*	11,4	14,7*	7,0	10,7	
10	on rail	14,6	23,4*	8,5	16,7*	5,2	12,9*	23'11"
	on tires	19,5	23,4*	11,2	16,2	7,0	10,7	
5	on rail	14,3	26,4*	8,4	18,3*	5,0	13,5*	24' 2"
	on tires	19,2	26,4*	11,1	16,0	6,8	10,4	
0	on rail	13,5	29,0*	7,8	18,5*	4,6	13,7*	23' 6"
	on tires	18,9	29,0*	10,5	16,4	6,4	10,1	
- 5	on rail	12,7	29,8*	7,1	19,3*	4,3	12,3*	21' 7"
	on tires	18,1	29,8*	9,8	15,8	6,1	9,7	
-10	on rail	12,2	28,0*	6,6	14,7*			17' 4"
	on tires	17,5	28,0*	9,3	14,7*			

Height Can be slewed through 360° In longitudinal position of undercarriage Max. reach \* Limited by hydr. capacity

The lift capacities are stated in lb x 1,000 with PowerLift of 5,439 psi at the stick end without attachment. This applies to a firm flat substrate with a closed steering axle. These capacities can be slewed through 360° with the undercarriage in the transverse position. Capacities in the longitudinal position of the undercarriage (+/- 15°) are specified over the steering axle with the stabilizers raised. The values apply when the adjusting cylinder is in the optimal position. Indicated loads based on the ISO 10567 standard and do not exceed 75% of tipping or 87% of hydraulic capacity, or are limited by the permissible load of the load lift hook.

Please note that the stability will be reduced by approx. 20% in case of a 3.9° cant and 40% in case of a 7.9° cant.

# Lift capacities

with offset two-piece boom 16'5" (rear + front outriggers)

## Stick 6'1"

ft	Undercarriage	10 ft		15 ft		20 ft		ft in	
25	on rail	15,6	18,4*			11,0	12,4*		
	on tires	18,4*	18,4*			12,4*	12,4*	12'2"	
	rear + front outriggers down	18,4*	18,4*			12,4*	12,4*		
20	on rail	15,9	17,3*	8,4	14,5*		5,8	9,2*	
	on tires	17,3*	17,3*	11,4	14,5*		8,1	9,2*	
	rear + front outriggers down	17,3*	17,3*	14,3	14,5*		9,2*	18'	
15	on rail	15,2	21,3*	8,6	15,4*	4,9	12,9*	4,3	8,2*
	on tires	20,4	21,3*	11,5	15,4*	6,8	10,7	6,1	8,2*
	rear + front outriggers down	21,3*	21,3*	14,1	15,4*	8,8	12,9*	7,9	8,2*
10	on rail	14,5	21,8*	8,5	17,3*	4,9	13,3*	3,7	7,9*
	on tires	19,6	21,8*	11,3	16,4	6,9	10,7	5,3	7,9*
	rear + front outriggers down	21,8*	21,8*	13,8	17,3*	8,8	13,3*	6,9	7,9*
5	on rail	14,4	26,4*	8,2	18,5*	4,8	13,6*	3,4	8,0*
	on tires	19,5	26,4*	11,2	16,3	6,7	10,5	5,0	8,0
	rear + front outriggers down	24,6	26,4*	13,9	18,5*	8,6	13,6*	6,6	8,0*
0	on rail	13,2	29,4*	7,6	18,7*	4,5	13,7*	3,6	8,7*
	on tires	18,9	29,4*	10,6	16,8	6,4	10,1	5,2	8,3
	rear + front outriggers down	25,2	29,4*	13,6	18,7*	8,3	13,7*	6,8	8,7*
- 5	on rail	12,7	30,3*	6,9	19,2*	4,2	10,1*	4,1	9,2*
	on tires	18,3	30,3*	9,8	15,9	6,1	9,9	6,0	9,2*
	rear + front outriggers down	24,7	30,3*	12,8	19,2*	8,1	10,1*	7,8	9,2*
-10	on rail	12,2	24,2*					7,0	12,0*
	on tires	17,8	24,2*					10,1	12,0*
	rear + front outriggers down	24,2	24,2*					12,0*	12,0*

## Stick 6'9"

ft	Undercarriage	10 ft		15 ft		20 ft		ft in	
25	on rail	15,9	17,2*					9,8	10,2*
	on tires	17,2*	17,2*					10,2*	10,2*
	rear + front outriggers down	17,2*	17,2*					10,2*	10,2*
20	on rail			8,6	14,0*			5,5	7,9*
	on tires			11,6	14,0*			7,7	7,9*
	rear + front outriggers down			14,0*	14,0*			7,9*	7,9*
15	on rail	15,3	20,5*	8,7	15,1*	5,1	12,6*	4,2	7,2*
	on tires	20,5*	20,5*	11,5	15,1*	7,0	10,8	5,9	7,2*
	rear + front outriggers down	20,5*	20,5*	14,2	15,1*	9,0	12,6*	7,2*	7,2*
10	on rail	14,6	22,8*	8,5	17,1*	5,1	13,2*	3,6	7,0*
	on tires	19,6	22,8*	11,3	16,4	7,0	10,8	5,1	7,0*
	rear + front outriggers down	22,8*	22,8*	13,9	17,1*	8,9	13,2*	6,7	7,0*
5	on rail	14,4	26,5*	8,3	18,4*	4,9	13,6*	3,3	7,2*
	on tires	19,4	26,5*	11,3	16,3	6,8	10,6	4,9	7,2*
	rear + front outriggers down	24,6	26,5*	13,8	18,4*	8,7	13,6*	6,4	7,2*
0	on rail	13,4	29,3*	7,7	18,7*	4,5	13,8*	3,4	7,9*
	on tires	19,1	29,3*	10,6	16,8	6,5	10,2	5,0	7,9*
	rear + front outriggers down	25,1	29,3*	13,7	18,7*	8,4	13,8*	6,6	7,9*
- 5	on rail	12,7	30,1*	7,0	19,3*	4,3	11,4*	3,9	9,3*
	on tires	18,3	30,1*	9,9	16,0	6,2	9,9	5,7	9,2
	rear + front outriggers down	24,8	30,1*	12,9	19,3*	8,1	11,4*	7,5	9,3*
-10	on rail	12,2	26,4*	6,6	12,9*			6,0	10,6*
	on tires	17,8	26,4*	9,5	12,9*			8,6	10,6*
	rear + front outriggers down	24,2	26,4*	12,5	12,9*			10,6*	10,6*

## Stick 7'5"

ft	Undercarriage	10 ft		15 ft		20 ft		ft in	
25	on rail							8,6*	8,6*
	on tires							8,6*	8,6*
	rear + front outriggers down							8,6*	8,6*
20	on rail			8,8	13,6*			5,2	6,9*
	on tires			11,7	13,6*			6,9*	6,9*
	rear + front outriggers down			13,6*	13,6*			6,9*	6,9*
15	on rail	15,4	18,8*	8,7	14,7*	5,2	12,3*	4,0	6,4*
	on tires	18,8*	18,8*	11,5	14,7*	7,1	10,9	5,6	6,4*
	rear + front outriggers down	18,8*	18,8*	14,2	14,7*	9,1	12,3*	6,4*	6,4*
10	on rail	14,6	23,4*	8,5	16,7*	5,2	12,9*	3,4	6,3*
	on tires	19,6	23,4*	11,3	16,4	7,1	10,9	4,9	6,3*
	rear + front outriggers down	23,4*	23,4*	13,8	16,7*	9,0	12,9*	6,3*	6,3*
5	on rail	14,3	26,4*	8,4	18,3*	5,0	13,5*	3,2	6,5*
	on tires	19,4	26,4*	11,3	16,2	6,9	10,6	4,7	6,5*
	rear + front outriggers down	24,4	26,4*	13,8	18,3*	8,8	13,5*	6,1	6,5*
0	on rail	13,4	29,0*	7,8	18,5*	4,6	13,7*	3,3	7,2*
	on tires	19,2	29,0*	10,7	16,5	6,5	10,2	4,8	7,2*
	rear + front outriggers down	24,9	29,0*	13,7	18,5*	8,4	13,7*	6,3	7,2*
- 5	on rail	12,7	29,8*	7,1	19,3*	4,3	12,3*	3,7	8,5*
	on tires	18,3	29,8*	9,9	16,1	6,2	9,9	5,4	8,5*
	rear + front outriggers down	24,8	29,8*	13,0	19,3*	8,1	12,3*	7,1	8,5*
-10	on rail	12,2	28,0*	6,6	14,7*			5,3	9,5*
	on tires	17,8	28,0*	9,4	14,7*			7,6	9,5*
	rear + front outriggers down	24,2	28,0*	12,4	14,7*			9,5*	9,5*

Height Can be slewed through 360° In longitudinal position of undercarriage Max. reach \* Limited by hydr. capacity

The lift capacities are stated in lb x 1,000 with PowerLift of 5,439 psi at the stick end without attachment. This applies to a firm flat substrate with a closed steering axle. These capacities can be slewed through 360° with the undercarriage in the transverse position. Capacities in the longitudinal position of the undercarriage (+/- 15°) are specified over the steering axle with the stabilizers raised and over the rigid axle with the stabilizers down. The values apply when the adjusting cylinder is in the optimal position. Indicated loads based on the ISO 10567 standard and do not exceed 75% of tipping or 87% of hydraulic capacity, or are limited by the permissible load of the load lift hook.

Please note that the stability will be reduced by approx. 20% in case of a 3.9° cant and 40% in case of a 7.9° cant.

# Lift capacities

with offset two-piece boom 16'5" (rear + front outriggers, heavy counterweight)

## Stick 6'1"

ft	Undercarriage	10 ft		15 ft		20 ft		ft in
25	on rail	16,6	18,4*			11,7	12,4*	12'2"
	on tires	18,4*	18,4*			12,4*	12,4*	
	rear + front outriggers down	18,4*	18,4*			12,4*	12,4*	
20	on rail	16,8	17,3*	9,0	14,5*		6,3	18'
	on tires	17,3*	17,3*	12,1	14,5*		8,6	
	rear + front outriggers down	17,3*	17,3*	14,5*	14,5*		9,2*	
15	on rail	16,2	21,3*	9,2	15,4*	5,3	12,9*	21'1"
	on tires	21,3*	21,3*	12,0	15,4*	7,3	11,3	
	rear + front outriggers down	21,3*	21,3*	14,8	15,4*	9,3	12,9*	
10	on rail	15,5	21,8*	9,1	17,3*	5,4	13,3*	22'8"
	on tires	20,5	21,8*	11,9	17,1	7,3	11,3	
	rear + front outriggers down	21,8*	21,8*	14,5	17,3*	9,3	13,3*	
5	on rail	15,4	26,4*	8,8	18,5*	5,2	13,6*	23'1"
	on tires	20,4	26,4*	11,9	17,0	7,2	11,1	
	rear + front outriggers down	25,6	26,4*	14,5	18,5*	9,1	13,6*	
0	on rail	14,2	29,4*	8,2	18,7*	4,9	13,7*	22'5"
	on tires	20,1	29,4*	11,2	17,5	6,8	10,7	
	rear + front outriggers down	26,2	29,4*	14,4	18,7*	8,8	13,7*	
- 5	on rail	13,7	30,3*	7,5	19,2*	4,7	10,1*	20'5"
	on tires	19,5	30,3*	10,5	16,8	6,6	10,1*	
	rear + front outriggers down	26,2	30,3*	13,6	19,2*	8,6	10,1*	
-10	on rail	13,2	24,2*				7,7	14'6"
	on tires	19,0	24,2*				10,8	
	rear + front outriggers down	24,2*	24,2*				12,0*	

## Stick 6'9"

ft	Undercarriage	10 ft		15 ft		20 ft		ft in
25	on rail	16,9	17,2*					13' 4"
	on tires	17,2*	17,2*					
	rear + front outriggers down	17,2*	17,2*					
20	on rail			9,2	14,0*			18' 8"
	on tires			12,2	14,0*			
	rear + front outriggers down			14,0*	14,0*			
15	on rail	16,3	20,5*	9,3	15,1*	5,5	12,6*	21' 8"
	on tires	20,5*	20,5*	12,1	15,1*	7,5	11,4	
	rear + front outriggers down	20,5*	20,5*	14,8	15,1*	9,5	12,6*	
10	on rail	15,6	22,8*	9,1	17,1*	5,5	13,2*	23' 4"
	on tires	20,6	22,8*	11,9	17,1*	7,5	11,4	
	rear + front outriggers down	22,8*	22,8*	14,5	17,1*	9,5	13,2*	
5	on rail	15,4	26,5*	8,9	18,4*	5,3	13,6*	23' 8"
	on tires	20,4	26,5*	11,9	17,0	7,3	11,2	
	rear + front outriggers down	25,6	26,5*	14,5	18,4*	9,3	13,6*	
0	on rail	14,3	29,3*	8,3	18,7*	5,0	13,8*	22'11"
	on tires	20,2	29,3*	11,3	17,3	6,9	10,8	
	rear + front outriggers down	26,1	29,3*	14,5	18,7*	8,9	13,8*	
- 5	on rail	13,7	30,1*	7,6	19,3*	4,7	11,4*	21'
	on tires	19,5	30,1*	10,6	16,9	6,7	10,5	
	rear + front outriggers down	26,2	30,1*	13,7	19,3*	8,6	11,4*	
-10	on rail	13,2	26,4*	7,2	12,9*			16'
	on tires	19,0	26,4*	10,2	12,9*			
	rear + front outriggers down	25,6	26,4*	12,9*	12,9*			

## Stick 7'5"

ft	Undercarriage	10 ft		15 ft		20 ft		ft in
25	on rail					8,6*	8,6*	14' 4"
	on tires					8,6*	8,6*	
	rear + front outriggers down					8,6*	8,6*	
20	on rail			9,4	13,6*			19' 6"
	on tires			12,3	13,6*			
	rear + front outriggers down			13,6*	13,6*			
15	on rail	16,4	18,8*	9,3	14,7*	5,6	12,3*	22' 5"
	on tires	18,8*	18,8*	12,1	14,7*	7,6	11,5	
	rear + front outriggers down	18,8*	18,8*	14,7*	14,7*	9,6	12,3*	
10	on rail	15,6	23,4*	9,1	16,7*	5,6	12,9*	23'11"
	on tires	20,6	23,4*	11,8	16,7*	7,6	11,5	
	rear + front outriggers down	23,4*	23,4*	14,5	16,7*	9,6	12,9*	
5	on rail	15,3	26,4*	9,0	18,3*	5,4	13,5*	24' 2"
	on tires	20,3	26,4*	11,8	16,9	7,4	11,2	
	rear + front outriggers down	25,5	26,4*	14,4	18,3*	9,3	13,5*	
0	on rail	14,4	29,0*	8,3	18,5*	5,0	13,7*	23' 6"
	on tires	20,3	29,0*	11,4	17,2	7,0	10,9	
	rear + front outriggers down	25,9	29,0*	14,5	18,5*	9,0	13,7*	
- 5	on rail	13,7	29,8*	7,6	19,3*	4,7	12,3*	21' 7"
	on tires	19,5	29,8*	10,6	17,0	6,6	10,5	
	rear + front outriggers down	26,2	29,8*	13,7	19,3*	8,6	12,3*	
-10	on rail	13,2	28,0*	7,2	14,7*			17' 4"
	on tires	19,0	28,0*	10,1	14,7*			
	rear + front outriggers down	25,6	28,0*	13,2	14,7*			

Height Can be slewed through 360° In longitudinal position of undercarriage Max. reach \* Limited by hydr. capacity

The lift capacities are stated in lb x 1,000 with PowerLift of 5,439 psi at the stick end without attachment. This applies to a firm flat substrate with a closed steering axle. These capacities can be slewed through 360° with the undercarriage in the transverse position. Capacities in the longitudinal position of the undercarriage (+/- 15°) are specified over the steering axle with the stabilizers raised and over the rigid axle with the stabilizers down. The values apply when the adjusting cylinder is in the optimal position. Indicated loads based on the ISO 10567 standard and do not exceed 75% of tipping or 87% of hydraulic capacity, or are limited by the permissible load of the load lift hook.

Please note that the stability will be reduced by approx. 20% in case of a 3.9° cant and 40% in case of a 7.9° cant.



# Clamshell grab

with two-piece boom 16'7"

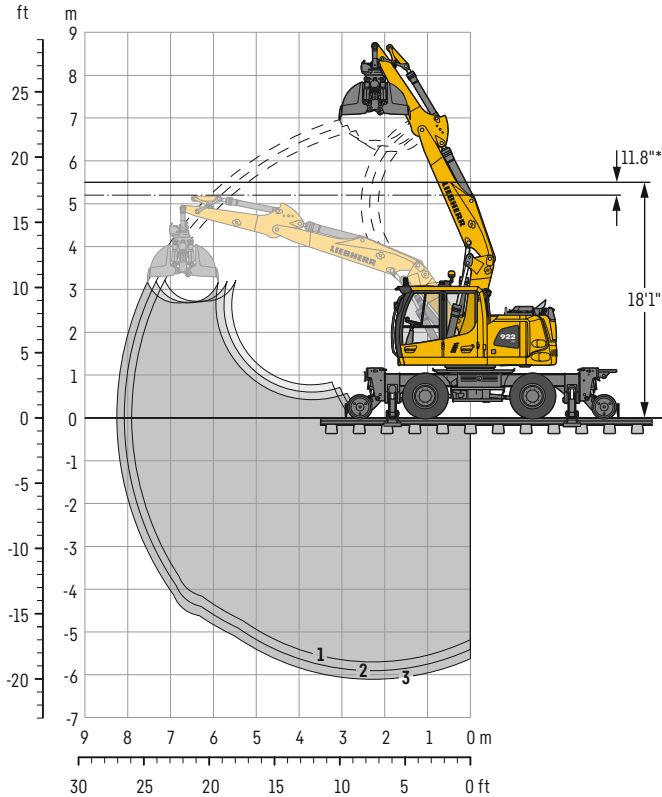

\* Safety distance to overhead wires

## Digging envelope

		1	2	3
Stick length	ft in	6' 1"	6' 9"	7' 5"
Max. digging depth	ft in	18' 8"	19' 4"	20'
Max. reach at ground level	ft in	25' 11"	26' 7"	27' 1"
Max. dumping height	ft in	20' 6"	20' 10"	21' 2"
Max. dumping height under overhead wires	ft in	8' 11"	8' 11"	8' 10"

## Operating weight

The operating weight includes the basic machine with 8 tires plus intermediate rings, two-piece boom 16'7", stick 7'5" and clamshell grab GMZ 22 / 0.39 yd<sup>3</sup>.

Undercarriage versions	Weight (lb)
A 922 Rail Litronic without outriggers (Asymmetric Rail)	46,100
A 922 Rail Litronic without outriggers (Symmetric Rail)	46,100
A 922 Rail Litronic with rear + front outriggers	49,800

## Clamshell grabs GMZ 22 Machine stability per ISO 10567\* (75% of tipping capacity)

Width of clamshells ft in	Capacity yd <sup>3</sup>	Weight lb	without outriggers						Rear + front outriggers on tires			down					
			on rail			on tires			on rail			on tires			down		
			Stick length (ft in)			Stick length (ft in)			Stick length (ft in)			Stick length (ft in)			Stick length (ft in)		
1' <sup>1)</sup>	0.10	1,488	6'1"	6'9"	7'5"	6'1"	6'9"	7'5"	6'1"	6'9"	7'5"	6'1"	6'9"	7'5"	6'1"	6'9"	7'5"
1'8" <sup>2)</sup>	0.21	1,631	■	■	■	■	■	■	■	■	■	■	■	■	■	■	■
2' <sup>2)</sup>	0.26	1,698	■	■	■	■	■	■	■	■	■	■	■	■	■	■	■
2'4" <sup>2)</sup>	0.31	1,786	■	■	■	■	■	■	■	■	■	■	■	■	■	■	■
2'7" <sup>2)</sup>	0.37	1,852	■	■	■	■	■	■	■	■	■	■	■	■	■	■	■
3'3" <sup>2)</sup>	0.44	1,995	■	■	■	■	■	■	■	■	■	■	■	■	■	■	■
2' <sup>3)</sup>	0.39	1,874	■	■	■	■	■	■	■	■	■	■	■	■	■	■	■
2'7" <sup>3)</sup>	0.55	2,039	■	■	■	■	■	■	■	■	■	■	■	■	■	■	■
3'3" <sup>3)</sup>	0.71	2,216	■	■	△	■	■	■	■	■	■	■	■	■	■	■	■

\* Indicated loads are based on ISO 10567 and do not exceed 75% of tipping or 87% of hydraulic capacity, max. stick length without quick coupler, lifted 360° on firm with blocked oscillating axle

<sup>1)</sup> Track construction bucket

<sup>2)</sup> Combination bucket

<sup>3)</sup> Clamshell bucket

Max. material weight ■ = ≤ 3,034 lb/yd<sup>3</sup>, ■ = ≤ 2,528 lb/yd<sup>3</sup>, △ = ≤ 2,023 lb/yd<sup>3</sup>, - = not authorized

# Dimensions for transport / Choice of bogie systems

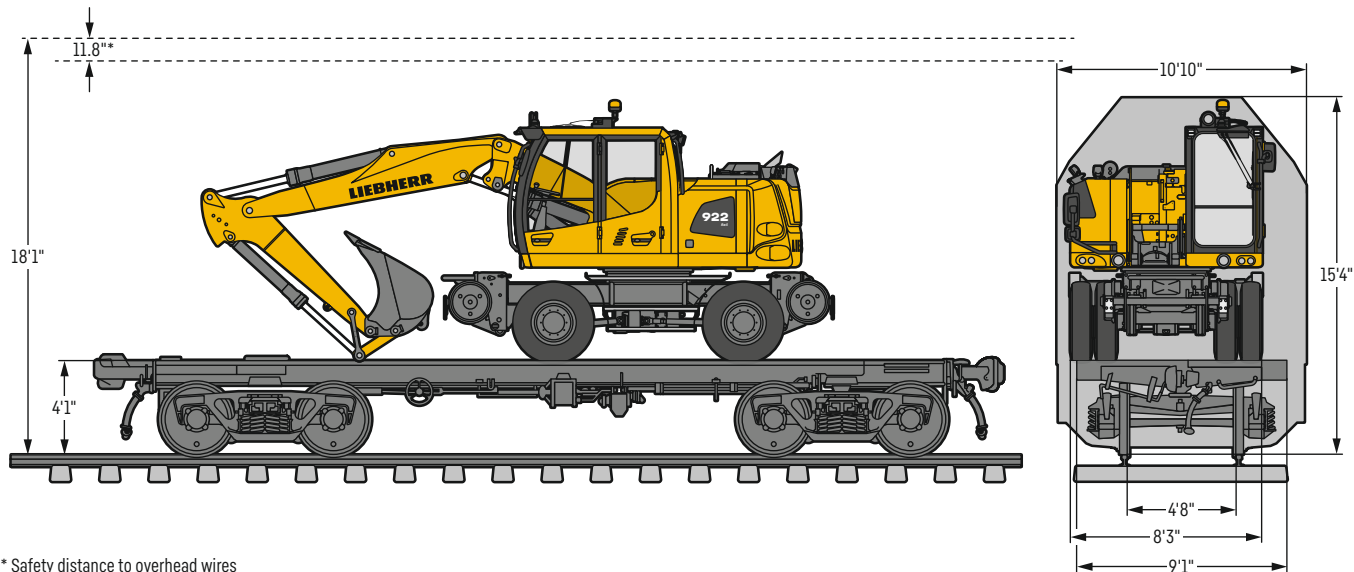

\* Safety distance to overhead wires

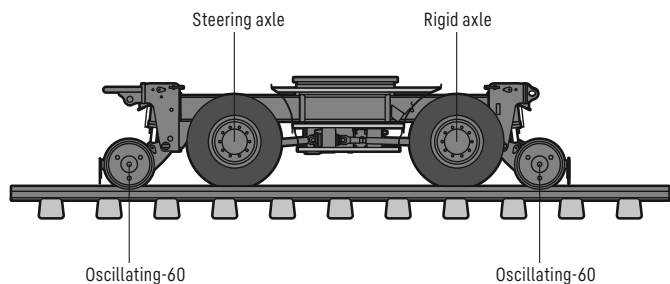

## Variant A

steering axle end oscillating-60  
rigid axle end oscillating-60

**Area of application**  
for rail track unevenness

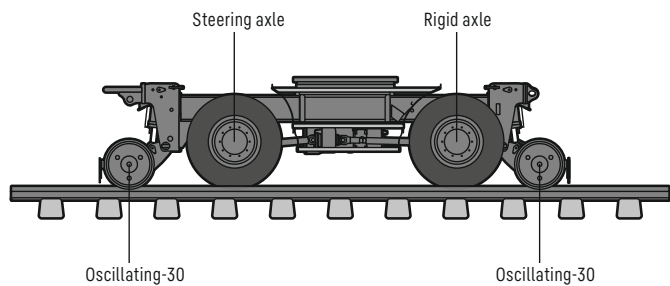

## Variant B

steering axle end oscillating-30  
rigid axle end oscillating-30

**Area of application**  
for heavy loads / rear + front outriggers

# Attachments

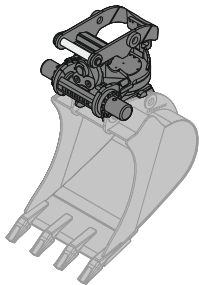

## Tilt rotator

Mounting machine side	SW stick mechanical, SWA 33 mechanical, SWA 33 hydraulic, SWA 33 LIKUFIX, SWA 48 mechanical, SWA 48 LIKUFIX						
<b>TR 20</b>							
Mountings attachment side	SW stick mechanical, SWA 33 mechanical, SWA 33 hydraulic, SWA 48 mechanical						
Weight <sup>1)3)</sup>	lb	1,113 - 1,268					
Rotation	360°						
Tilt	2 x 50°						
<b>TR 25</b>							
Mountings attachment side	SW stick mechanical, SWA 33 mechanical, SWA 33 hydraulic, SWA 48 mechanical, SWA 48 hydraulic						
Weight <sup>1)3)</sup>	lb	1,411 - 1,554					
Rotation	360°						
Tilt	2 x 50°						

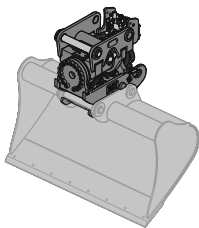

## Tilt unit

<b>LiTiU 33</b>							
Mounting machine side	SWA 33 LIKUFIX						
Mountings attachment side	SWA 33 hydraulic, SWA 33 LIKUFIX						
Weight <sup>1)3)</sup>	lb	838 - 904					
Tilt	2 x 50°						
<b>LiTiU 48</b>							
Mounting machine side	SWA 48 LIKUFIX						
Mountings attachment side	SWA 48 hydraulic, SWA 48 LIKUFIX						
Weight <sup>2)3)</sup>	lb	1,543 - 1,631					
Tilt	2 x 45°						

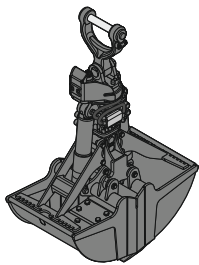

## Clamshell grab GMZ 22 / GMZ 22 HD<sup>4)</sup>

Mountings	direct mounting, SW stick mechanical, SWA 33 mechanical, SWA 33 hydraulic, SWA 33 LIKUFIX, SWA 48 mechanical, SWA 48 hydraulic, SWA 48 LIKUFIX						
<b>Clamshell buckets</b>							
Shell width	ft in	1'	1'4"	2'	2'7"	3'3"	
Opening width	ft in	4'11"	4'11"	4'11"	4'11"	4'11"	
Capacity	yd <sup>3</sup>	0.18	0.26	0.39	0.55	0.71	
Weight <sup>1)</sup>	lb	1,973	2,039	2,260	2,436	2,601	
<b>Track construction buckets</b>							
Shell width	ft in	1'					
Opening width	ft in	3'9"					
Capacity	yd <sup>3</sup>	0.10					
Weight <sup>1)</sup>	lb	1,797					
<b>Combination buckets</b>							
Shell width	ft in	1'4"	1'8"	2'	2'4"	2'7"	3'3"
Opening width	ft in	4'	4'	4'	4'	4'	4'
Capacity	yd <sup>3</sup>	0.16	0.21	0.26	0.31	0.37	0.44
Weight <sup>1)</sup>	lb	1,841	1,973	2,083	2,172	2,238	2,381

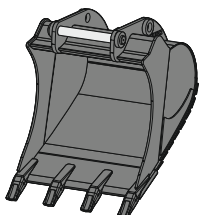

## Backhoe bucket 03

Mountings	direct mounting, SW stick mechanical, SWA 33 mechanical, SWA 33 hydraulic, SWA 33 LIKUFIX, SWA 48 mechanical, SWA 48 hydraulic, SWA 48 LIKUFIX							
Cutting width	ft in	1'	1'4"	1'8"	2'2"	2'9"	3'5"	4'1"
Capacity	yd <sup>3</sup>	0.22	0.31	0.42	0.55	0.78	1.05	1.24
Weight <sup>1)</sup>	lb	518	573	672	794	915	1,091	1,190

<sup>1)</sup> weights based on an attachment in a standard design with the machine SWA 33 LIKUFIX mounting

<sup>2)</sup> weights based on an attachment in a standard design with the machine SWA 48 LIKUFIX mounting

<sup>3)</sup> depending on the mounting on the attachment

<sup>4)</sup> 44 lb additional weight for HD version



# Attachments

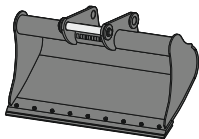

## Universal bucket 03

Mountings	SWA 33 mechanical, SWA 33 hydraulic, SWA 33 LIKUFIX, SWA 48 mechanical, SWA 48 hydraulic, SWA 48 LIKUFIX		
Cutting width	ft in	4'11"	
Capacity	yd <sup>3</sup>	0.78	
Weight <sup>1)</sup>	lb	849	

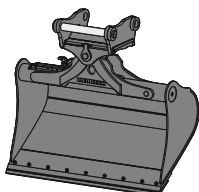

## Tilt bucket 90

Mountings	direct mounting, SW stick mechanical, SWA 33 mechanical, SWA 33 hydraulic, SWA 33 LIKUFIX, SWA 48 mechanical, SWA 48 hydraulic, SWA 48 LIKUFIX		
Cutting width	ft in	4'11"	5'3"
Capacity	yd <sup>3</sup>	0.78	1.05
Weight <sup>1)</sup>	lb	1,543	1,731
Tilt angle		2 x 50°	2 x 50°

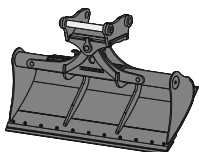

## Ditch cleaning bucket

Mountings	direct mounting, SW stick mechanical, SWA 33 mechanical, SWA 33 hydraulic, SWA 33 LIKUFIX, SWA 48 mechanical, SWA 48 hydraulic, SWA 48 LIKUFIX			
-----------	--	--	--	--

### GRL 90

Cutting width	ft in	5'3"	5'3"	6'7"	7'3"
Capacity	yd <sup>3</sup>	0.72	1.05	0.65	1.05
Weight <sup>1)</sup>	lb	1,510	1,797	1,554	1,852
Tilt angle		2 x 50°	2 x 50°	2 x 50°	2 x 50°

### GRL 90 Rail

Cutting width	ft in	6'7"	6'7"
Capacity	yd <sup>3</sup>	0.92	1.31
Weight <sup>1)</sup>	lb	1,808	1,918
Tilt angle		2 x 50°	2 x 50°

### GRL rigid 2B

Cutting width	ft in	2'	2'7"	3'3"	3'11"	4'7"	5'3"	5'11"	6'7"
Capacity	yd <sup>3</sup>	0.22	0.33	0.39	0.50	0.59	0.65	0.75	0.85
Weight <sup>1)</sup>	lb	408	474	540	606	683	772	838	904

### GRL rigid Rail

Cutting width	ft in	5'3"	6'7"
Capacity	yd <sup>3</sup>	1.05	0.63
Weight <sup>1)</sup>	lb	1,036	816

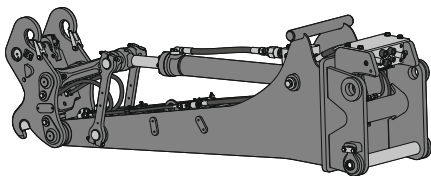

## Stick extension LS 12

Mounting machine side	SWA 33 LIKUFIX, SWA 48 LIKUFIX	
Mountings attachment side	SWA 33 mechanical, SWA 33 mechanical LIKUFIX <sup>2)</sup> , SWA 33 hydraulic <sup>4)</sup> , SWA 33 LIKUFIX <sup>3)4)5)</sup>	
Length	ft in	7'5"
Weight <sup>1)</sup>	lb	approx. 1,279 - 1,389

<sup>1)</sup> weights based on an attachment in a standard design with the machine SWA 33 LIKUFIX mounting

<sup>2)</sup> attachment with high pressure circuit only possible with the manual switchover tipping cylinder or an extended hydraulic circuit on the carrier machine

<sup>3)</sup> attachment with high pressure circuit only possible with the electric switchover tipping cylinder or an extended hydraulic circuit on the carrier machine

<sup>4)</sup> 14-pole signal contact strip is required, for example to control and monitor the hydraulic quick coupling system on the stick extension on the attachment side or to transfer electrical signals for the switchover

<sup>5)</sup> a socket on the stick above the signal contact strip for the carrier machine is also required for switching between different hydraulic circuits

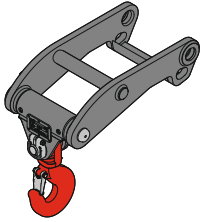

### Load lift hook

Mountings		direct mounting, SW stick mechanical, SWA 33 mechanical, SWA 33 hydraulic, SWA 48 mechanical, SWA 48 hydraulic
Max. load	lb	17,637
Rotatable		360°, mechanical
Height to bolting point	ft in	1'8"
Weight <sup>1)</sup>	lb	265

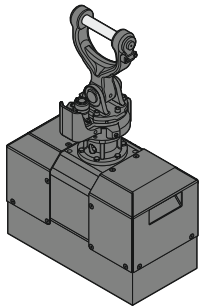

### Hydro magnet

Mountings		direct mounting, SW stick mechanical, SWA 33 mechanical, SWA 33 hydraulic, SWA 33 LIKUFIX, SWA 48 mechanical, SWA 48 hydraulic, SWA 48 LIKUFIX
Power	kW	5
Lifting capacity	lb	11,023
Swivel circuit		330°
Overall height to bearing fork	ft in	3'11"
Weight <sup>1)</sup>	lb	3,274

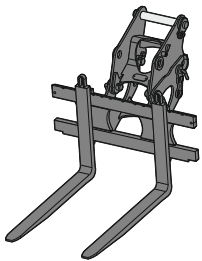

### Pallet fork

Mountings		direct mounting, SW stick mechanical, SWA 33 mechanical, SWA 33 hydraulic, SWA 33 LIKUFIX, SWA 48 mechanical, SWA 48 hydraulic, SWA 48 LIKUFIX
Max. width pallet fork	ft in	4'1"
Pallet forks length	ft in	3'11"
Lifting capacity (ISO 2328)	lb	5,512
Weight <sup>1)</sup>	lb	728

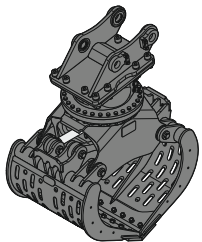

### Sorting grab

		perforated	ribbed	closed	perforated	ribbed	closed	perforated	closed	perforated	closed
Mountings		direct mounting, SW stick mechanical, SWA 33 mechanical, SWA 33 hydraulic, SWA 33 LIKUFIX, SWA 48 mechanical, SWA 48 hydraulic, SWA 48 LIKUFIX									
<b>SG 20B</b>											
Shell width	ft in	2'7"	2'7"	2'7"	3'3"	3'3"	3'3"	3'11"	3'11"	4'7"	4'7"
Capacity	yd <sup>3</sup>	0.52	0.52	0.65	0.65	0.78	0.78	0.92	0.92	0.92	0.92
Max. closing force	lbf	8,992	8,992	8,992	8,992	8,992	8,992	8,992	8,992	8,992	8,992
Weight <sup>1)</sup>	lb	2,017	2,039	2,105	2,138	2,205	2,238	2,293	2,337		
<b>SG 25B</b>											
Shell width	ft in	2'7"	2'7"	2'7"	3'3"	3'3"	3'3"	3'11"	3'11"	4'7"	4'7"
Capacity	yd <sup>3</sup>	0.72	0.65	0.72	0.98	0.85	0.98	1.18	1.18	1.44	1.44
Max. closing force	lbf	13,489	13,489	13,489	13,489	13,489	13,489	13,489	13,489	13,489	13,489
Weight <sup>1)</sup>	lb	2,579	2,690	2,624	2,723	2,866	2,778	2,866	2,921	3,042	3,120

<sup>1)</sup> weights based on an attachment in a standard design with the machine SWA 33 LIKUFIX mounting

# Equipment

## Undercarriage

Dual-circuit braking system with rail wheel brake, hydraulically	•
Support frame, lockable (front and rear)	+
Add-on-axle	+
Bumper (front and rear)	+
Trailer coupling Rockinger, semi-automatic	•
Lighting system white / red incl. power socket*	+
Earthing cable with ball-headed pin	X
Fire extinguisher 13 lb	X
Grab suspension bracket	+
Drag shoe, 2 pieces	•
Load holding valve on each stabilization cylinder	•
Line protection for rail guide cylinders	+
Parking brake, maintenance-free	•
Outrigger with individual control	+
Rear + front outriggers	+
Tire inflation hose on wagon braking system	+
Tires, variants	+
Rail undercarriage friction wheel, gauge 3'3" (not available in combination with rear + front outriggers)	+
Rail undercarriage convertible (position and pressure control)	+
Rail guide axles, oscillating 30 on the steering and rigid axle side	•
Rail guide axles, oscillating 60 on the steering and rigid axle side	+
Rail guide, gauge 4'8"	•
Rail guide, gauge 5'3"	+
Rail sweeper, swivelling	X
Narrow excavator axles with wheel head width of 6'11"	+
Protection for oscillating axle cylinders	+
Proportional servo-steering with emergency function	•
Speeder*	+
Two storage compartments	•
Storage compartment with drawer	+
Power socket 24 V / 10 A (front / rear)	+
Lashing eyelets for transport	•
Wagon braking system (pneumatic, 1 circuit)	•
Wagon braking system (pneumatic, 2 circuits)	+
Tool equipment, extended	+
Pull rod	X

## Upper carriage

Uppercarriage rear light, 2 pieces, LED	+
Uppercarriage right side light, 1 piece, LED	•
Counterweight (tail swing radius 6'7")	•
Counterweight (tail swing radius 6'7"), heavy	+
Refuelling system with filling pump	+
External starting aid (battery connectors)	+
Handrails, non slip surfaces	•
Main battery switch for electrical system	•
Engine hood with gas spring	•
Uppercarriage doors, lockable	•
Amber beacon, at uppercarriage, LED double flash	+
Signal light DB, halogen	X
Signal light DB, LED	+

## Hydraulic system

Shut-off valve between hydraulic tank and pump(s)	•
Pressure test fittings	•
Electronic pump regulation	•
Hydraulic oil filter with integrated microfilter	•
Liebherr hydraulic oil from -4 °F to +104 °F	•
Liebherr hydraulic oil, biologically degradable	+
Liebherr hydraulic oil, specially for warm or cold regions	+
Bypass filter	+
Emergency actuation, electric	X
Switchover clamshell operation and tipping cylinder (not available in combination with LIKUFIX)	•
Switchover high pressure circuit 1 and tipping cylinder	+
Switchover high pressure circuit 1 and two-piece boom	+
Preparation Liebherr hydro-magnet	+

## Diesel engine

Fuel anti-theft device	+
Sensor controlled engine idling	•
Liebherr particle filter*	•
Air pre-filter with dust discharge	+
Preheating hydraulic oil	+
Preheating fuel	+
Preheating engine oil	+

## Work space limitation

Electronic lift limitation	X
Load torque limitation (RCL)	X
Load torque warning (RCI)	+
Swivel limitation	X
Virtual wall	+



## Cab

Storage compartment	•
Activation of the lighting (compliant with the Road Traffic Licensing authority) for tramway operations	+
Cab lights rear, 2 pieces, LED	•
Cab lights front, 2 pieces, LED (under rain cover)	•
Exterior mirror, electrical adjustable, with heating	+
Control elements for signal-horn and emergency brake at co-driver's seat	•
Lighting for cab access	x
Mechanical hour meters, readable from outside the cab	•
Roof window made from impact-resistant laminated safety glass	•
Data logger	•
Two seater cab	•
Circular bubble level	+
Pressure indication of rail axles on the display	•
Driver identification code	+
Driver profile, personalized	•
Operator's seat Standard	•
Operator's seat Comfort	+
Operator's seat Premium	+
Driving alarm (acoustic signal is emitted during travel, can be switched ON / OFF)	+
Fire extinguisher 4 lb	+
Windscreen retractable (including upper part)	•
Intermittent windscreen wiper with wiper washer	•
Footrest	+
Speed indication on the rail-display	•
Cruise control*	•
Rubber floor mat, removable	•
High pressure circuit, permanent drive	•
Dome light	•
Licence plate holder with light*	+
Coat hook	•
Automatic air conditioning	•
Fuel consumption indicator	•
Electric cooler	+
Steering wheel lock	•
Steering column adjustable	•
LiDAT, vehicle fleet management* / **	•
Emergency exit rear window	•
Positioning swing brake	+
Proportional control	•
Radio Comfort, control via display with handsfree set	+
Preparation for radio installation	•
Rain cover over front window opening	•
ROPS cab	•
Back-up alarm (acoustic signal is emitted traveling backward, can not be switched off)	+
Amber beacon, on cab, LED double flash	+
Windshield wiper with interval switching and washer, roof window	•
Windshield wiper with interval switching and washer, rear window	•
Driver door with sliding window	•
Slipcover for operator seat	+
Right side window and windshield made from laminated safety glass	•
Safety components DB (safety flag, signal horn, warning triangle, warning light, first-aid box)	x
Sun blind	•
Auxiliary heating, adjustable (week time switch)	+
Power socket 12 V	•
Left control console, folding	•
Electronic immobilizer	+
Cigarette lighter / power socket 24 V	•

## Equipment

Alternative connection medium pressure circuit on right side of stick	+
Boom lights, 2 pieces, LED	•
Stick lights, 2 pieces, LED	+
Grab lines for stick with tipping kinematic	+
High pressure circuit 1 incl. unpressurized return line and Tool Control	•
High pressure circuit 2 incl. lines	•
Load holding valve tipping cylinder, both sides	+
Load holding valve tipping cylinder, single-sided	+
Load lug on boom	+
Load lug on stick	+
Leak oil line, additional for attachments	+
Stick prepared for quick coupler stick	•
Medium pressure circuit incl. lines	•
PowerLift	•
Pipe fracture safety valves hoist cylinders	•
Pipe fracture safety valve stick cylinder	•
Hose quick coupling at grab lines	•
Hose protection for LIKUFIX	+
Quick coupling system LIKUFIX-9 SWA 33	+
Quick coupling system LIKUFIX SWA 33	+
Quick coupling system LIKUFIX SWA 48	+
Signal contacts for LIKUFIX, 14-pin	+
Signal contacts for LIKUFIX, 14-pin, with control unit for second SWA	+
Special buckets and other attachments	+
Power socket on stick, commutable (2 circuits)	+
Tool Control, 20 attachment adjustments selectable over the display	•
Tool Management, automatic attachment recognition (in combination with LIKUFIX)	+
Latching for connecting link in grab operation	+
Two-piece boom	•
Offset two-piece boom	+
Cylinders with end damping	•

## Complete machine

<b>Machine guidance system</b>	
Preparation	+
<b>Lubrication</b>	
Lubrication undercarriage, manually - decentralized (grease points)	+
Lubrication undercarriage steering axle, manually - centralized (one grease point)	•
Central lubrication system for uppercarriage and equipment, automatically (without quick coupler and connecting link)	•
Centralized lubrication extended for quick coupler	+
Centralized lubrication extended for connecting link	+
<b>Special coating</b>	
DB-coating	x
Special coating undercarriage, uppercarriage, equipment	+
<b>Monitoring</b>	
Rear view monitoring with camera	•
Side view monitoring with camera	•

• = Standard, + = Option, x = Required for acceptance by the German RR (DB)

\* = country-dependent, \*\* = optionally extendable after one year

Options and /or special equipment, supplied by vendors other than Liebherr, are only to be installed with the knowledge and approval of Liebherr in order to retain warranty.

# The Liebherr group of companies



## Diverse Product Range

The Liebherr Group is one of the largest construction equipment manufacturers in the world. Liebherr's quality products and services hold a high reputation in many industries. The wide range includes domestic appliances, aerospace and transportation systems, machine tools and maritime cranes.

## Exceptional Customer Benefit

Every product line provides a complete range of models in many different versions. With both their technical excellence and superior quality, Liebherr products offer customers the highest benefits in practical applications.

## State-of-the-art Technology

Liebherr attributes great importance to the product areas of core technology and components, in order to achieve its consistent, top-quality products. Important modules and components are developed and manufactured in-house, for instance, the entire drive and control technology for the construction equipment and mining trucks.

## Worldwide and Family-Owned

Hans Liebherr founded the Liebherr family company in 1949. Since that time, the enterprise has steadily grown to a group of more than 140 companies with nearly 48,000 employees located on all continents. The corporate headquarters of the Group is Liebherr-International AG in Bulle, Switzerland. The Liebherr family is the sole owner of the company.

[www.liebherr.us](http://www.liebherr.us)

### **WARNING**

Breathing diesel engine exhaust exposes you to chemicals known to the State of California to cause cancer and birth defects or other reproductive harm.

- Always start and operate the engine in a well-ventilated area.
- If in an enclosed area, vent the exhaust to the outside.
- Do not modify or tamper with exhaust system.
- Do not idle the engine except as necessary.

For more information go to [www.P65warnings.ca.gov/diesel](http://www.P65warnings.ca.gov/diesel).

### **WARNING**

This product can expose you to chemicals including lead and lead compounds, which are known to the State of California to cause cancer and birth defects or other reproductive harm.

For more information go to [www.P65warnings.ca.gov](http://www.P65warnings.ca.gov).

## Liebherr USA, Co.

Construction Equipment Division • 4800 Chestnut Avenue • Newport News, VA 23607, USA • Phone +1 (757) 240 4250  
[construction.usa@liebherr.com](mailto:construction.usa@liebherr.com) • [www.liebherr.us](http://www.liebherr.us) • [www.facebook.com/LiebherrConstruction](https://www.facebook.com/LiebherrConstruction)