

LH 150 Port Litronic

LIEBHERR

Material handling machine

Generation

6

Operating weight

286,600 – 485,000 lb*

System performance

614 kW

Engine

536 HP (I) / 400 kW

Stage V

Stage IIIA (compliant)

Tier 4 Final

Electric

* Without attachment

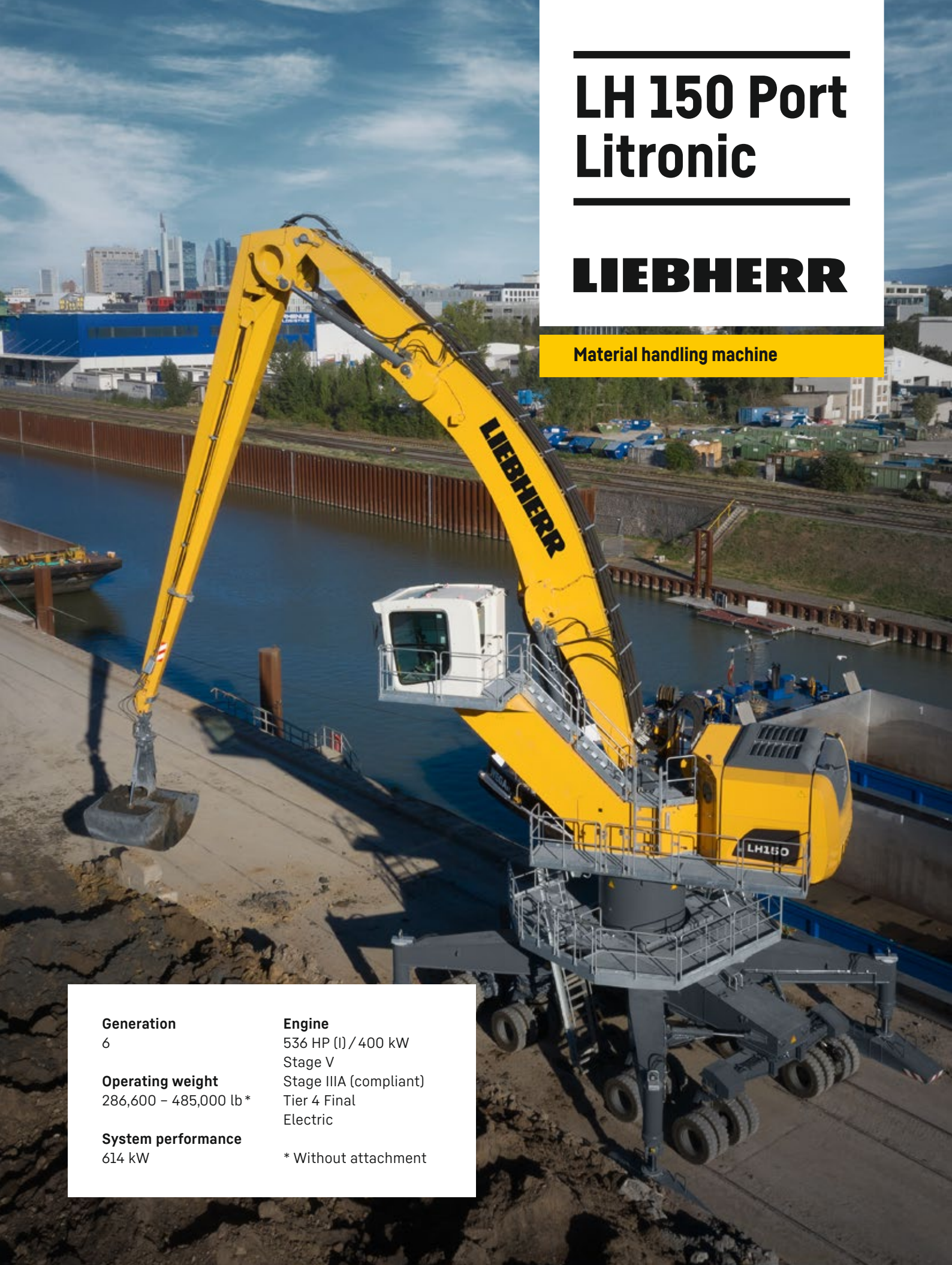

Performance

Power plus speed –
Redefined performance

Economy

Good investment –
Savings for the long-term

Reliability

Durability and sustainability –
Quality down to the last detail

Comfort

Perfection at a glance –
When technology is comfortable

Maintainability

Efficiency bonus –
Even with maintenance and service



LH 150 M Port Litronic

Operating weight
286,600 – 330,700 lb*
Engine
536 HP (I) / 400 kW
Stage V
Stage IIIA (compliant)
Tier 4 Final
System performance
614 kW

LH 150 C Port Litronic

Operating weight
286,600 – 341,700 lb*
Engine
536 HP (I) / 400 kW
Stage V
Stage IIIA (compliant)
Tier 4 Final
Electric
System performance
614 kW

LH 150 M High Rise Port Litronic

Operating weight
308,600 – 352,700 lb*
Engine
536 HP (I) / 400 kW
Stage V
Stage IIIA (compliant)
Tier 4 Final
System performance
614 kW



**LH 150 C High Rise Port
Litronic**

Operating weight
297,600 – 363,800 lb*

Engine
536 HP (I) / 400 kW
Stage V
Stage IIIA (compliant)
Tier 4 Final
Electric

System performance
614 kW

**LH 150 M Gantry Port
Litronic**

Operating weight
330,700 – 407,900 lb*

Engine
536 HP (I) / 400 kW
Stage V
Stage IIIA (compliant)
Tier 4 Final
Electric

System performance
614 kW

**LH 150 C Gantry Port
Litronic**

Operating weight
341,700 – 407,900 lb*

Engine
536 HP (I) / 400 kW
Stage V
Stage IIIA (compliant)
Tier 4 Final
Electric

System performance
614 kW

**LH 150 T Gantry Port
Litronic**

Operating weight
396,800 – 485,000 lb*

Engine
536 HP (I) / 400 kW
Stage V
Stage IIIA (compliant)
Tier 4 Final
Electric

System performance
614 kW

* Without attachment

Well thought out to the last detail





Maximum safety

- Safe and ergonomic access systems as well as optimal service accessibility for maximum safety
- Various camera systems always ensure the perfect overview during operation



Equipment

- High payloads and long reaches of up to 30 m thanks to enhanced weight design for increased handling capacity
- The weight-optimised equipment, ERC, hoist and stick cylinders are perfectly tailored to the conditions of use



Optimum maintenance accessibility

- Large, electro-hydraulic maintenance flaps and a walk-in engine compartment allow quick and safe access to all maintenance points

Convincing in operation



Performance

High engine performance

The 8 cylinder Liebherr V engine and the ERC system together gives a total system performance of 614 kW which ensures maximum handling output.

Unique mobility

The material handling machine is perfectly suited for narrow quays and terminals, thanks to different steering options. The mobile undercarriage of the LH 150 enable easy positioning of the machine due to the very small turning radius and the option of lateral movement. Individual control of each set of wheels is a great advantage, as the operator can position the machine specifically for the task in hand.

Rapid work cycles

The intuitive machine controls guarantee that the hydraulics are optimally configured for the task at hand. The Positive Control multi-circuit hydraulic system ensures optimum distribution of the pump flow. Speed and power are available whenever they are needed to ensure high handling capacity.

Economy

Alternative drive concept

The LH 150 electric machine is also available as an alternative to the conventional diesel drive. The Liebherr electric motor guarantees powerful and dynamic working movements with the lowest possible energy consumption. In addition, the standard frequency converter ensures the necessary flexibility in the respective application. Through its function as a speed controller, sensitive and dynamic working movements and speed are combined.

Closed hydraulic circuit for the swing mechanism

The closed slewing circuit feeds the braking energy back into the system when the uppercarriage is braked. This simple yet effective feature sets new standards in terms of efficiency and economy.

Reliability

Quality and competence

Our experience, understanding of customer needs and the technical implementation of these findings guarantee the success of the product. For decades, Liebherr has been inspirational with its extent of production and system solutions. Key components such as the diesel engine and electric motors, electronic components, slew ring, slew drives and hydraulic cylinders are developed and produced by Liebherr itself. The degree of in-house manufacturing guarantees maximum quality and ensures that components are optimally configured to each other.

Robust design

All steel components are designed and manufactured by Liebherr. High-strength steel plates configured for the toughest of requirements result in high torsional stiffness and optimum absorption of forces induced for a longer service life.

Working area limit

The handling machine can be fitted with an optional working area limit for jobs which require such a feature. Every possible dimension can be adjusted for this purpose – height, depth, reach and proximity. This can prevent collisions and the resulting component damage.

Comfort

Ergonomic

The latest cab design delivers excellent conditions for healthy, highly concentrated and productive work in maximum comfort. Both the display unit with touchscreen colour display, the controls and Comfort driver's seat are all coordinated to form a perfect ergonomic unit. In addition the ergonomic joysticks allow the machine operation to be both pleasant and precise.

Excellent all-round vision

The large areas of glass, different versions of cab elevations and the rear and side area monitoring systems provide the operator with an excellent view of their working area and the zone around the machine. This perfect view enhances the operator's safety and ensures that they can handle the machine safely at all times.

Proportional control

Precision and the fine control of the material handler are particularly important in applications such as ship loading and unloading in bulk goods and cargo. The machine can master this demanding work with ease thanks to its standard proportional control system.

Maintainability

Service-based machine design

The service-based machine design guarantees short servicing times, thus minimising maintenance costs. All the service points are positioned in close proximity to one another, are easily accessible from the ground or on catwalks and platforms, and easy to reach thanks to the large, wide-opening service doors. The enhanced service concept places the maintenance points close to each other and reduces their number to a minimum. This means that service work can be completed even more quickly and efficiently.

Integral maintenance benefits

Maintenance work helps to keep the machine fully functional. However this kind of work leads to machine downtimes which must be minimised. With change intervals of up to 2,000 hours for engine oil and up to 8,000 hours for hydraulic oil, Liebherr has significantly reduced the amount of maintenance and increased the productivity of the material handlers. In addition, central lubrication systems minimise daily maintenance.

Material handling machine overview

Equipment

- High lift capacities and long reaches thanks to weight-optimised design for more handling capacity
- Energy recovery cylinder filled with nitrogen for maximum efficiency through less fuel consumption at more handling capacity
- Pipe fracture safety valves on hoist and stick cylinders and retract stick shut-off for maximum safety during every application
- Electro-hydraulic end position control extends the service life of the components
- Quick coupling systems and attachments made by Liebherr for maximum machine capacity utilisation and greater handling performance

Operator's cab

- Hydraulic cab elevations for always the best view downwards as well as forwards
- Less strain on the operator, workers and reduced environmental pollution due to lower noise emissions
- Optimum visibility thanks to large glass surfaces and standard rear and side area monitoring with camera
- Large-capacity cab with trainer seat offers plenty of space and creates a pleasant feeling of space
- Proportional steering as standard with 4-way joystick for more functionality and greater precision and fine control

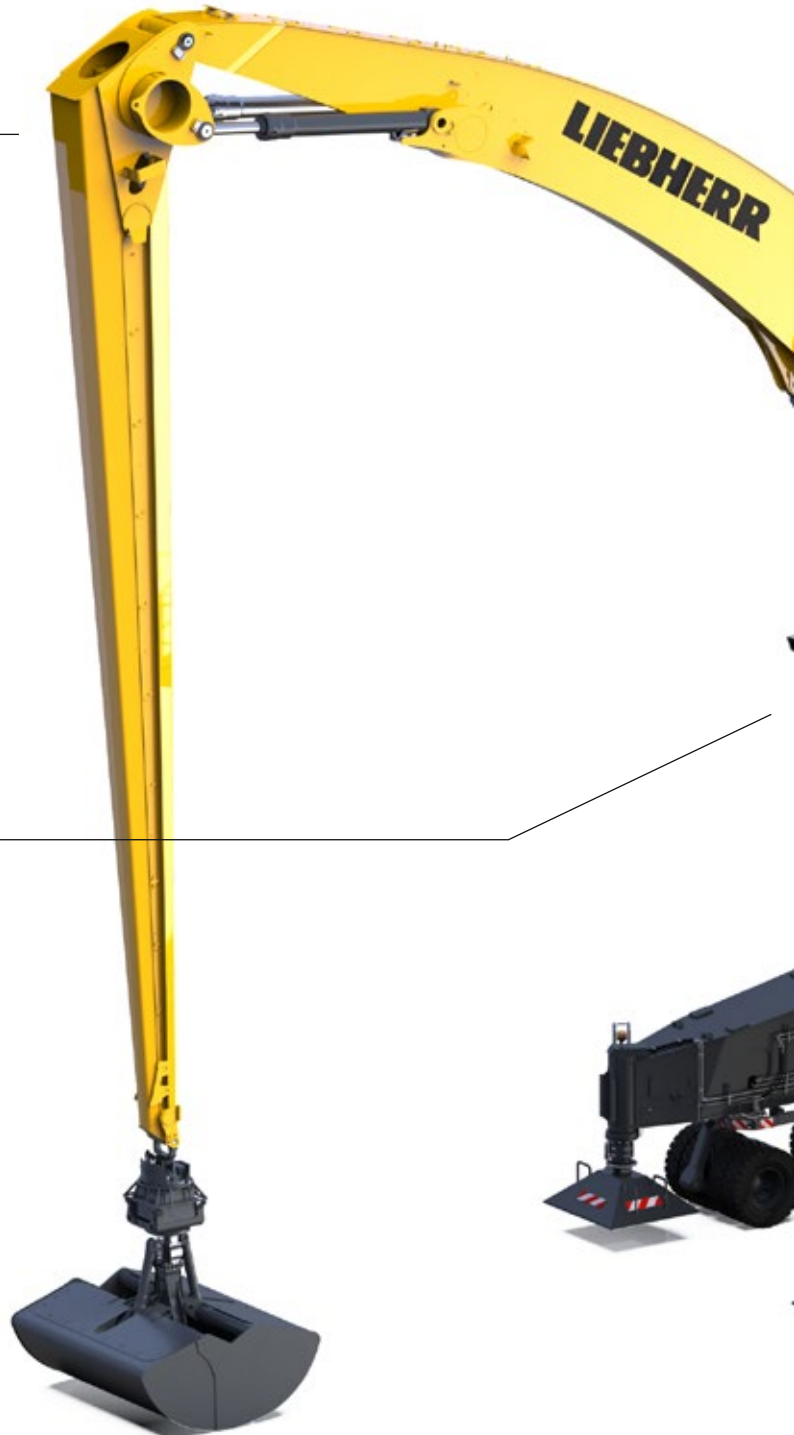



Uppercarriage

- Positive Control multi-circuit hydraulic system ensures faster working movements with minimum fuel consumption
- 400 kW engine output and high pump flow for fast work cycles, convincing dynamics and maximum handling performance
- Electrical pilot control enables individual settings for the operator and new options such as load torque limitation
- Reduction in operating costs thanks to built-in maintenance advantages and optimum service accessibility
- Unrestricted and easy access to all maintenance points

Undercarriage

- Maximum mobility and manoeuvrability through various steering modes on the mobile undercarriage
- Large footprint for high stability and maximum lift capacities
- Variety of undercarriage variants for different applications available
- Customer-specific solutions of the gantry undercarriage with regard to clearance width and height

The perfect solution for every application

Attachments

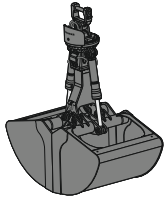

Grab for loose material



Multi-tine grab



Wood grab

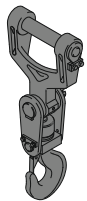

Load hook

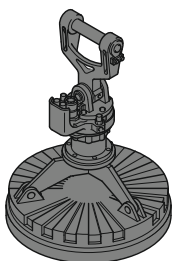

Magnet devices

Sticks

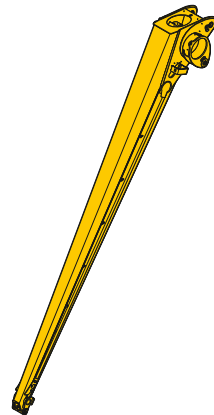

Straight stick

Booms

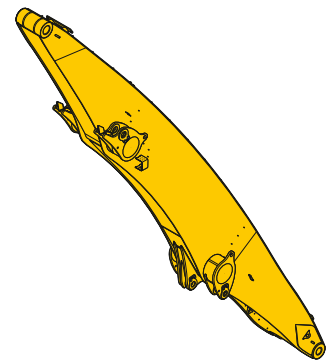

Straight boom

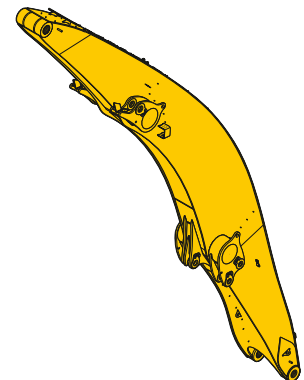

Angled boom

Cab elevations

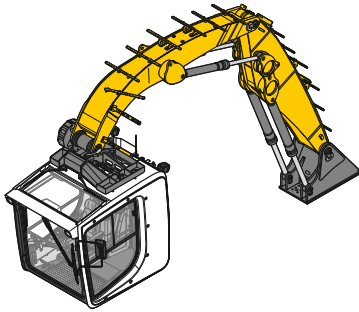

Hydraulic cab elevation

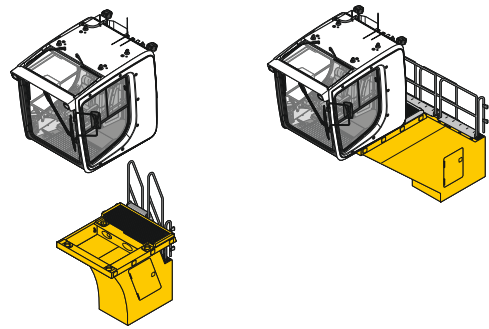

Rigid cab elevation

Uppercarriage

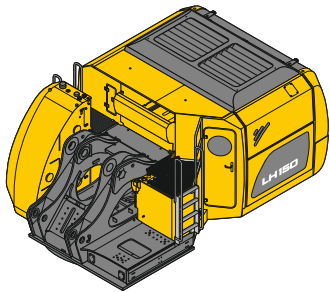

Diesel engine

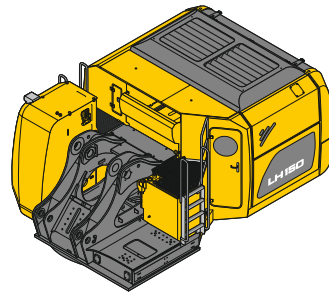

Electric engine

Undercarriage



Turret Elevations

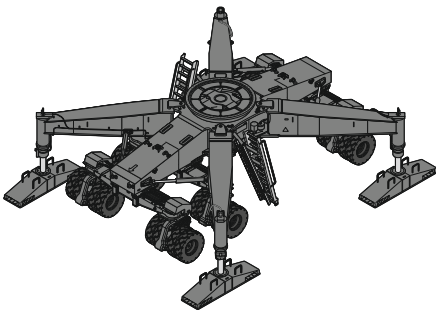

Mobile

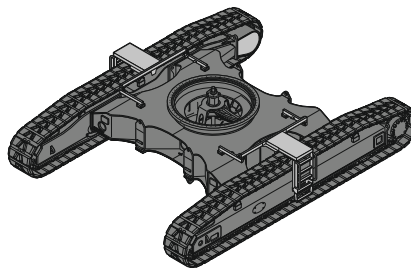

Crawler

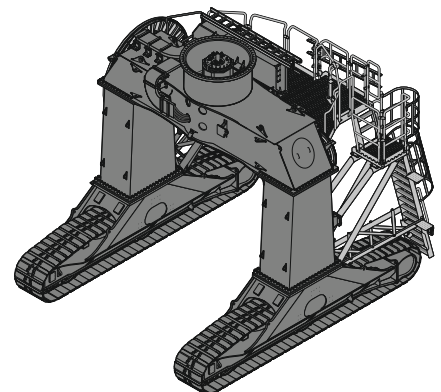

Gantry (Mobile, Crawler, Track)

Technical data



Diesel engine

Rating per SAE J1349 / ISO 9249	536 HP (I) (400 kW) at 1,700 rpm
Model	Liebherr D9508
Type	8 cylinder V-engine
Bore / Stroke	5.0 / 6.2 in
Displacement	986.1 in ³
Engine operation	4-stroke diesel Common-Rail Turbo-charged and after-cooled Reduced emissions
Air cleaner	Dry-type air cleaner with pre-cleaner, primary and safety elements
Engine idling	Sensor controlled
Electrical system	
Voltage	24 V
Batteries	4 x 180 Ah / 12 V
Alternator	Three-phase current 28 V / 180 A
Stage V	
Harmful emissions values	According to regulation (EU) 2016/1628
Emission control	Liebherr-SCR Filter technology
Fuel tank	750 gal
Urea tank	48 gal
Stage IIIA (compliant)	
Harmful emissions values	In accordance with ECE-R.96 Power Band H
Fuel tank	750 gal
Tier 4 Final	
Harmful emissions values	In accordance with 40CFR1039 (EPA) / 13CCR (CARB)
Emission control	Liebherr-SCR technology
Fuel tank	750 gal
Urea tank	48 gal



Electric motor

Rating	400 kW at 1,700 rpm
Model	Liebherr KGF1391
Type	Three-phase squirrel cage motor
Secondary electric motor	Electric motor auxiliary equipment (air-conditioning compressor, alternator 24 V) 15 kW
Electrical system energy supply	Liebherr drive components and control cabinets for uppercarriage and undercarriage Liebherr frequency converter fed drive system Heavy-duty version
Manufacturer	Liebherr
Supply voltage	
Low voltage	380-690 V
High voltage	2.14-20 kV
Frequency	50 / 60 Hz
Engine idling	Sensor controlled
Electrical system	Battery-assisted Control system, lighting, diagnostics system
Voltage	24 V
Batteries	2 x 180 Ah / 12 V
Alternator	Three-phase current 28 V / 140 A



Cooling system

Diesel engine	Water-cooled Cooling system, consisting of a cooling unit for water and charge air and a 2 nd cooler for hydraulic oil, each with an infinitely variable, thermostatically controlled fan drive system
Electric motor	Air-cooled Cooling system for hydraulic oil with an infinitely variable, thermostatically controlled fan drive system Frequency converter water-cooled



Hydraulic controls

Power distribution	Via control valves with integrated safety valves, simultaneous actuation of chassis and equipment. Swing drive in separate closed circuit
Servo circuit	
Equipment and swing	With electro-hydraulic pilot control and proportional joystick levers
Chassis	with electro-hydraulic pilot control and an additional proportional joystick lever
Additional functions	
Proportional control	Proportionally acting transmitters on the joysticks for additional hydraulic functions



Hydraulic system

Hydraulic pump	
For equipment and travel drive	4 Liebherr axial piston variable displacement pumps
Max. flow	4 x 73 gpm
Max. pressure	5,076 psi
For swing drive	Reversible axial piston variable displacement pump, closed-loop circuit
Max. flow	120 gpm
Max. pressure	3,771 psi
Hydraulic pump regulation and control	Positive Control multi-circuit hydraulic system for independent and demand controlled dosing via the hydraulic pumps; sensor-controlled
Hydraulic tank	227 gal
Hydraulic system	436-449 gal (depending on undercarriage version)
Filtration	3 main return filters with integrated partial micro filtration (5 µm), 1 high pressure filter for each main pump
MODE selection	Adjustment of engine and hydraulic performance via a mode pre-selector to match application, e.g. for especially economical and environmentally friendly operation or for maximum material handling and heavy-duty jobs
S (Sensitive)	Mode for precision work and lifting through very sensitive movements
E (Eco)	Mode for especially economical and environmentally friendly operation
P (Power)	Mode for high performance with low fuel consumption
P+ (Power-Plus)	Mode for highest performance and for very heavy duty applications, suitable for continuous operation



Swing drive

Drive	Liebherr axial piston motor in a closed system, Liebherr planetary reduction gear
Swing ring	Liebherr, sealed race ball bearing swing ring, internal teeth
Swing speed	0-5.5 rpm stepless
Swing torque	191,766 lbf ft
Holding brake	Wet multi-disc (spring applied, pressure released)
Option	Slewing gear brake Comfort



Cab

Cab	Spacious operator cabin with profiled design, excellent view on working area, access from behind, fixed front, roof and base panel made of bullet proof glass, front screen with electrical heating, shock-absorbing suspension, sound damping insulating, sliding window on left side, sun shadings, folding seat for instructor
Operator's seat Comfort	Air cushioned operator's seat with 3D-adjustable armrests, headrest, lap belt, seat heater, adjustable seat cushion inclination and length, lockable horizontal suspension, automatic weight adjustment, adjustable suspension stiffness, pneumatic lumbar vertebrae support and passive seat climatization with active coal
Operator's seat Premium (Option)	In addition to operator's seat comfort: active electronic weight adjustment (automatic readjustment), pneumatic low frequency suspension and active seat climatization with active coal and ventilator
Arm consoles	Joysticks with control consoles and swivel seat
Operation and displays	Large high-resolution operating unit, self-explanatory, color display with touchscreen, video-compatible, numerous setting, control and monitoring options, e.g. air conditioning control, fuel consumption respectively energy consumption, machine and attachment parameters
Air-conditioning	Automatic air-conditioning, recirculated air function, fast de-icing and demisting at the press of a button, air vents can be operated via a menu; recirculated air and fresh air filters can be easily replaced and are accessible from the outside; heating-cooling unit, designed for extreme outside temperatures, sensors for solar radiation, inside and outside temperatures
Diesel engine	
Electric motor	In addition to diesel engine: stationary air conditioning function with external climate condenser - controlled by a weekly timer



Equipment

Type	Weight-optimized design for bulk and general cargo handling at optimal handling capacity. Complex and stable mountings of equipment and cylinders
Hydraulic cylinders	Liebherr cylinders with special sealing and guide system and, depending on cylinder type, shock absorption
Energy recovering cylinder	Liebherr gas cylinder with special sealing and control system
Bearings	Sealed, low maintenance



Undercarriage

Mobile	
Versions	Standard, High Rise
Drive	One axle drive per drive axle with Liebherr axial piston motor and functional brake valve on both sides
Travel speed	0-2.6 mph stepless (creeper speed)
Joystick steering	0-4.8 mph stepless
Axles	Wheelsets with suspended 88,185 lb axles, with slewing drive rotating around the vertical axis, hydraulic cylinder for leveling
Position of wheelsets	6 steering axles, 2 powered and braked, for leveling and axle load distribution, interconnected by hydraulic
Option	8 steering axles, 2 powered and braked
Steering programs	Front wheel, rear wheel and all-wheel steering, move to the side in crab steering possible, turning on the spot
Service brake	Two circuit travel brake system with accumulator
Holding brake	Wet multi-disc (spring applied, pressure released)
Stabilization	X-shaped 4 point support with 4 folding arms, one vertically positioned support cylinder per folding arm, support plates with ball-and-socket joint, removable
Crawler	
Versions	SW, High Rise, Gantry
Drive	Liebherr compact planetary reduction gear with Liebherr axial piston motor per side of undercarriage
Travel speed	0-1.1 mph stepless (creeper speed) 0-2.4 mph stepless
Brake	Functional brake valves on both sides
Holding brake	Wet multi-disc (spring applied, pressure released)
Track pads	Flat
Tracks	Sealed and greased
Rail-mounted Gantry	
Chassis	Rail travel drive designed for the respective load per undercarriage corner
Drive	Compact planetary reduction gear with axial piston motor per rail travel drive
Brake	Functional brake valves on both sides
Holding brake	Per rail travel drive wet multi-disc (spring applied, pressure released)
Storm brakes (Option)	Different designs



Complete machine

Lubrication	Liebherr central lubrication system for uppercarriage and equipment, automatically
Mobile (Option)	Liebherr central lubrication system for undercarriage, automatically
Steps system	Safe and durable access system with anti-slip steps; main components hot-galvanized
Noise emission	
ISO 6396 (Stage V)	71 dB(A) = L _{PA} (inside cab)
2000/14/EC (Stage V)	108 dB(A) = L _{WA} (surround noise)
ISO 6396 (Stage IIIA compliant)	71 dB(A) = L _{PA} (inside cab)
2000/14/EC (Stage IIIA compliant)	109 dB(A) = L _{WA} (surround noise)
ISO 6396 (Tier 4 Final)	71 dB(A) = L _{PA} (inside cab)
2000/14/EC (Tier 4 Final)	108 dB(A) = L _{WA} (surround noise)
ISO 6396 (Electric)	71 dB(A) = L _{PA} (inside cab)
2000/14/EC (Electric)	108 dB(A) = L _{WA} (surround noise)

LH 150 M – Dimensions

Port

Cab elevation LFC 250

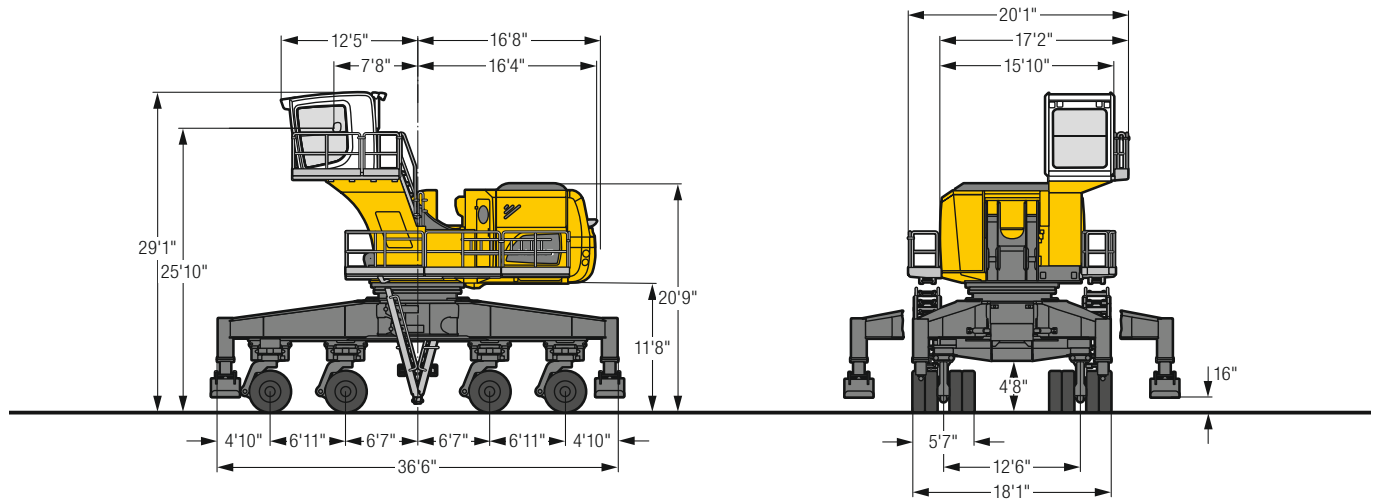

LH 150 M – Cab elevation

Cab elevation LFC 350 (rigid elevation)

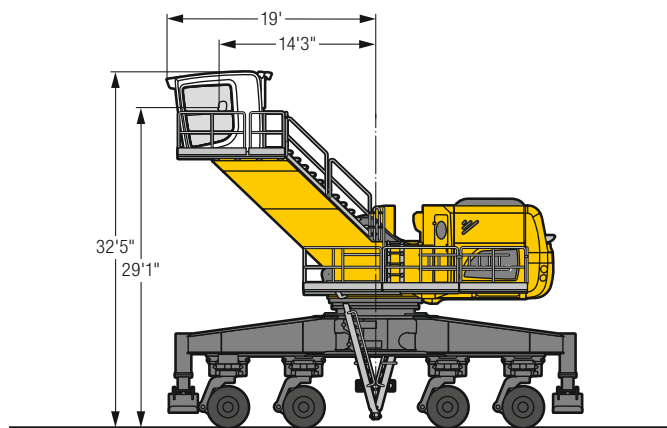

Tires 12.00-20

LH 150 M HR – Dimensions

Port

Cab elevation LFC 250

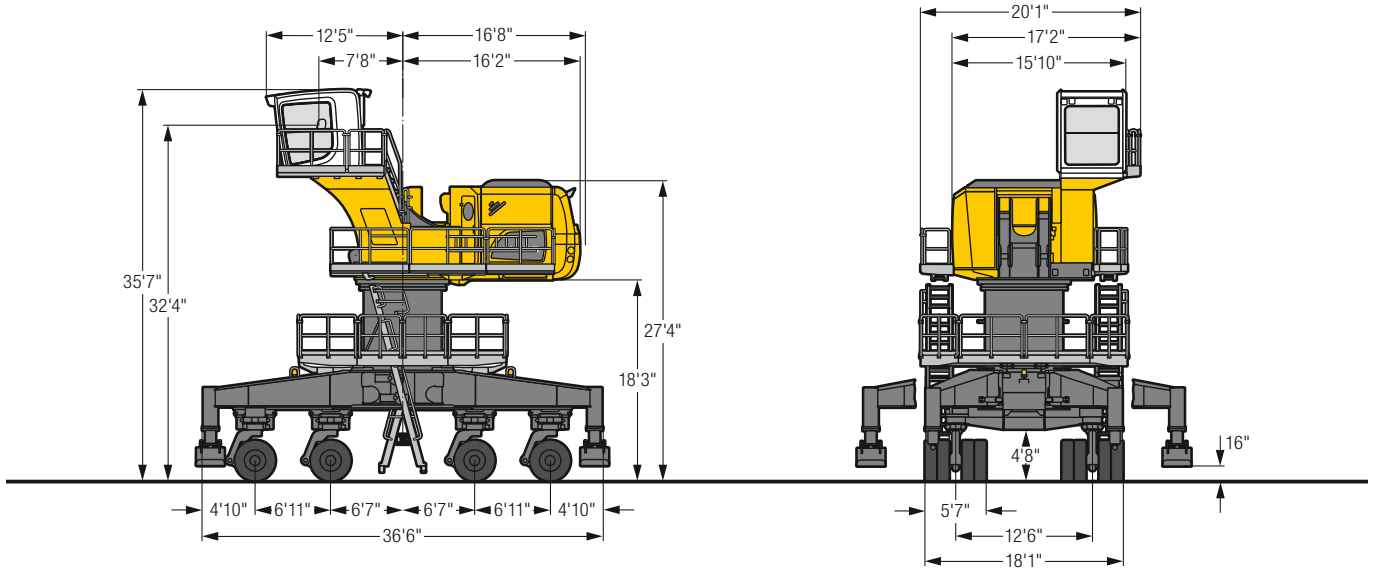

LH 150 M HR – Choice of cab elevation

Cab elevation LFC 350 (rigid elevation)

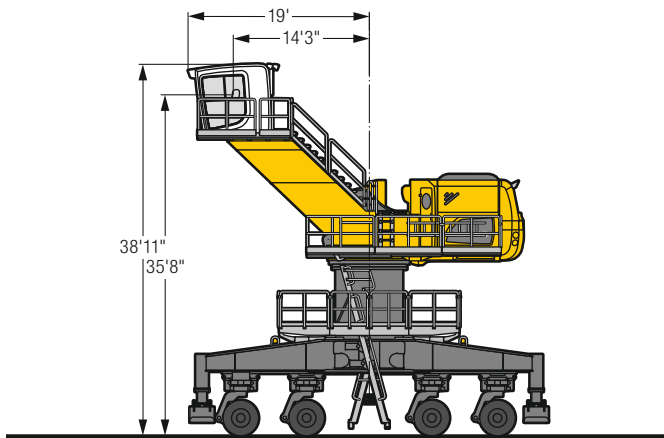

Cab elevation LHC-D 1090 T (hydraulic elevation)

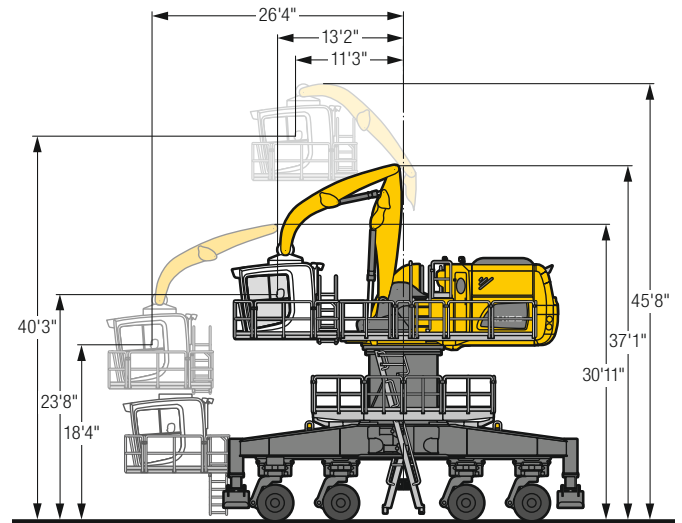

The hydraulically adjustable cab allows the driver, that he can choose his field of view freely and at any time within the stroke.

LH 150 M – Dimensions Undercarriage

Port

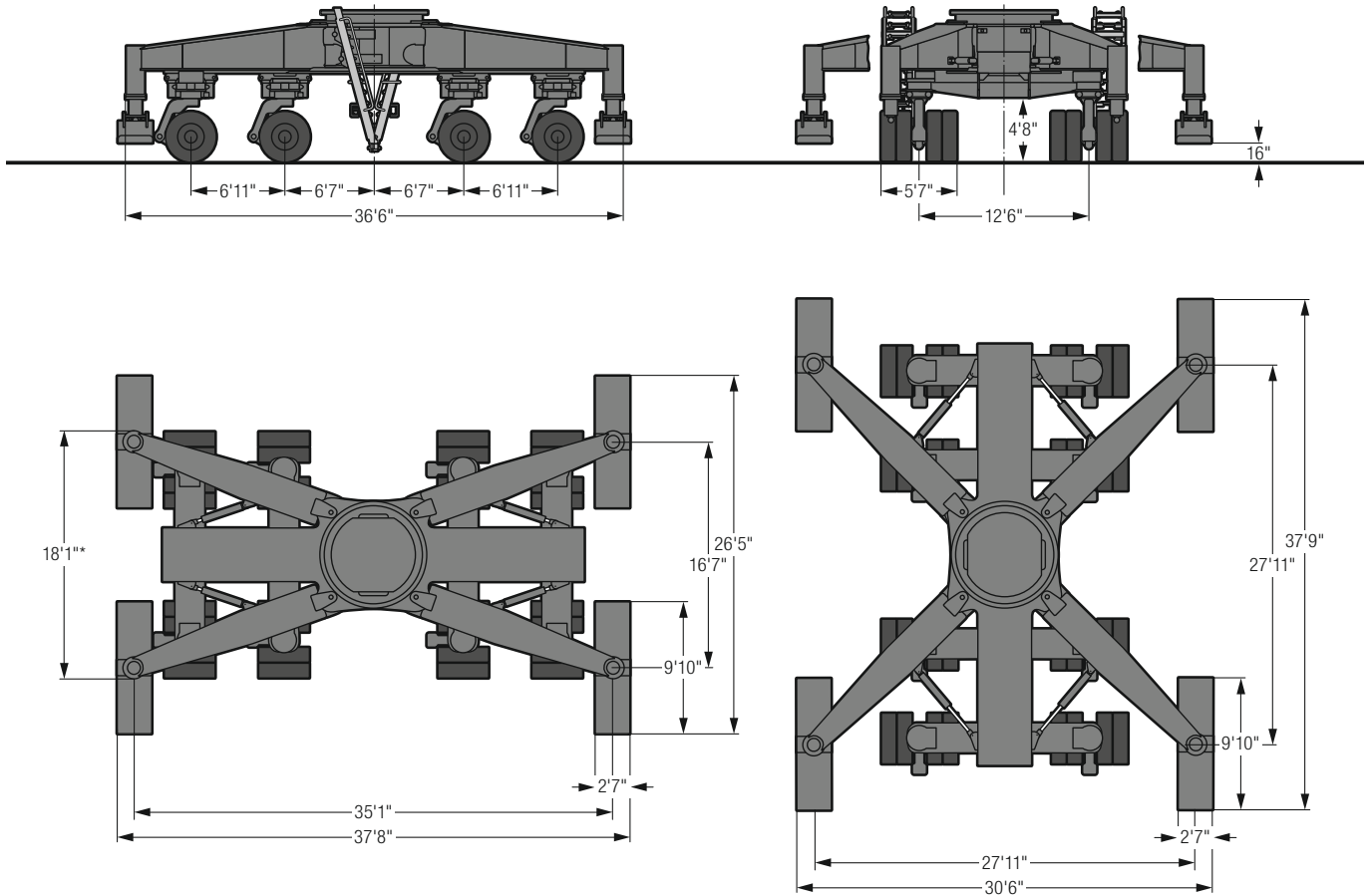

* with removed support plates

LH 150 M Gantry – Dimensions

Port

Cab elevation LFC 250

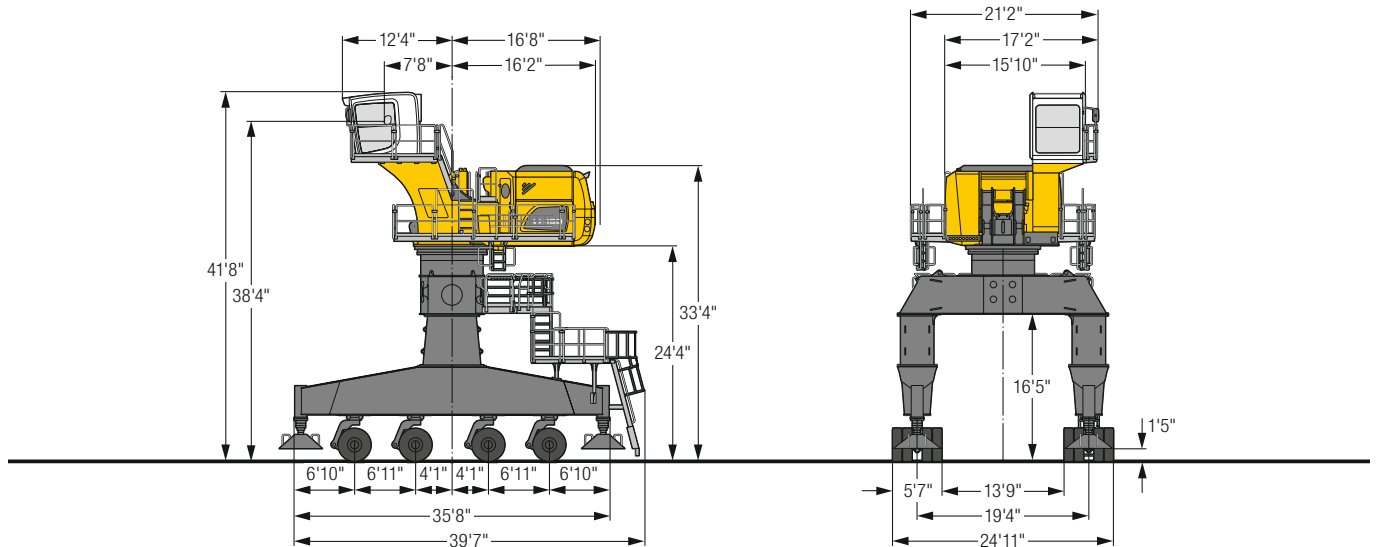

LH 150 M Gantry – Choice of cab elevation

Cab elevation LFC 350 (rigid elevation)

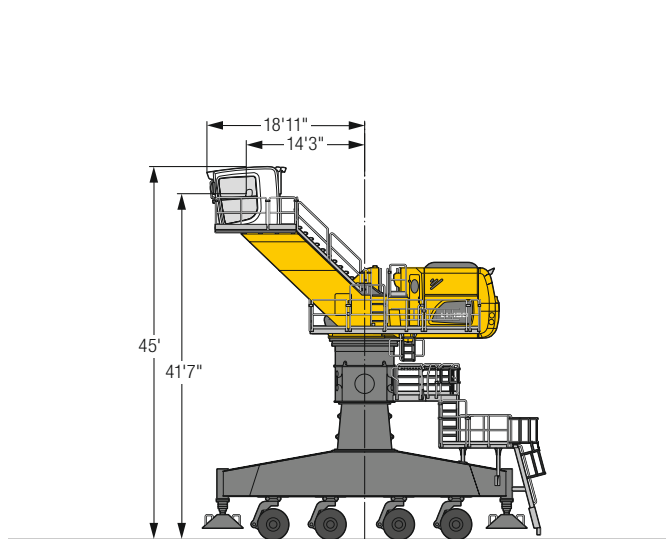

Cab elevation LHC-D 1090 T (hydraulic elevation)

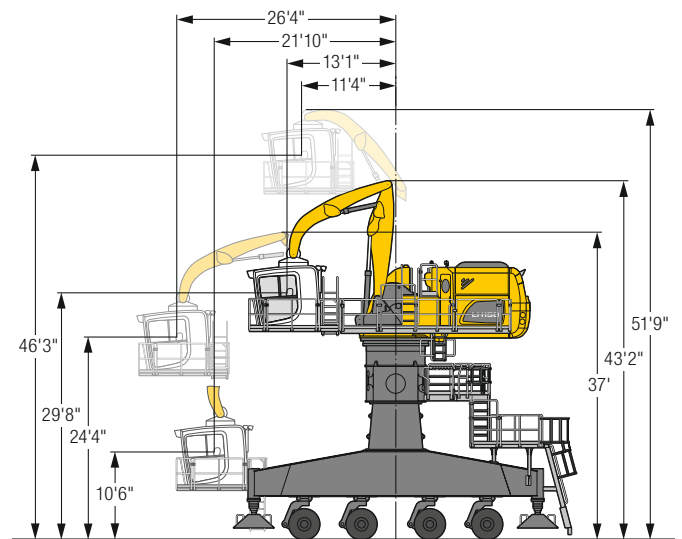

The hydraulically adjustable cab allows the driver, that he can choose his field of view freely and at any time within the stroke.

LH 150 C – Dimensions

Port

Cab elevation LFC 250

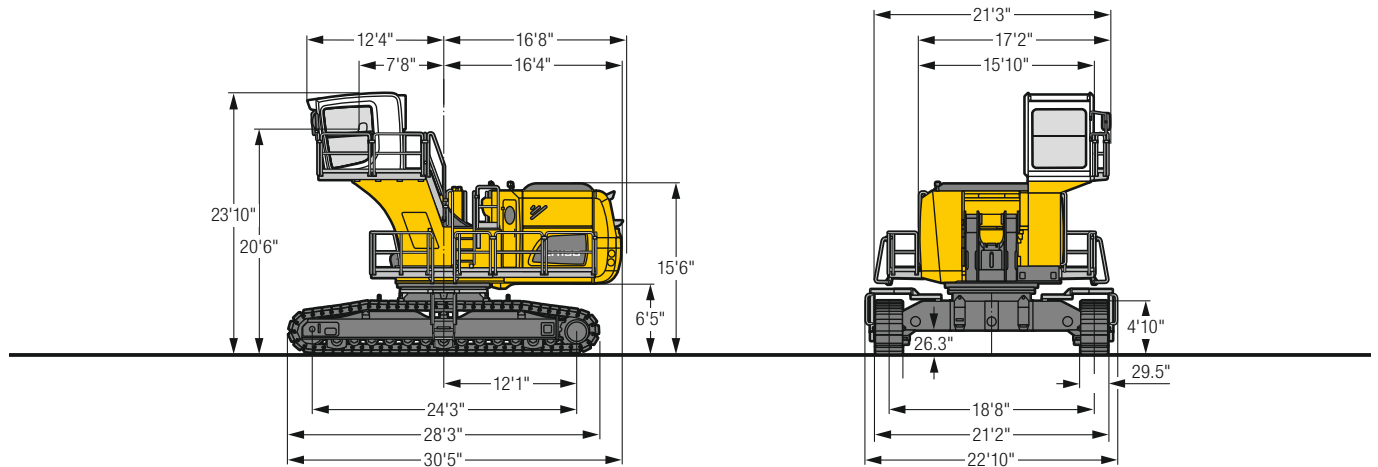

LH 150 C – Cab elevation

Cab elevation LFC 350 (rigid elevation)

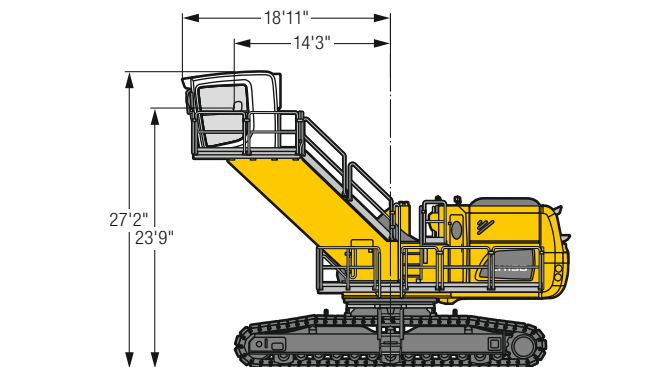

LH 150 C HR – Dimensions

Port

Cab elevation LFC 250

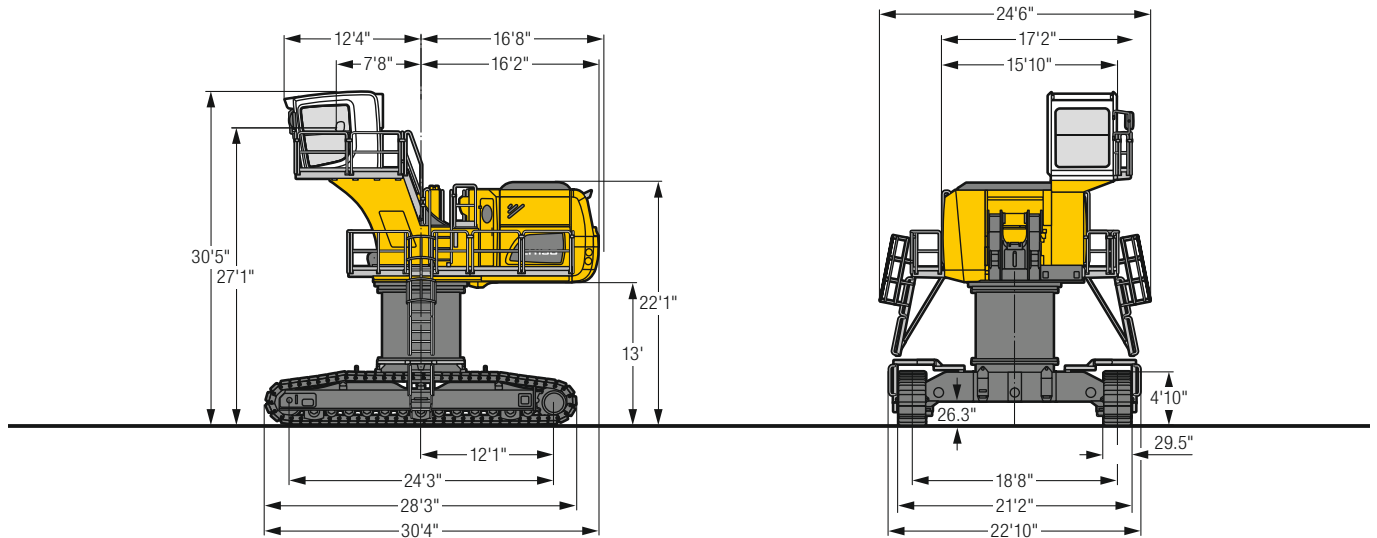

LH 150 C HR – Choice of cab elevation

Cab elevation LFC 350 (rigid elevation)

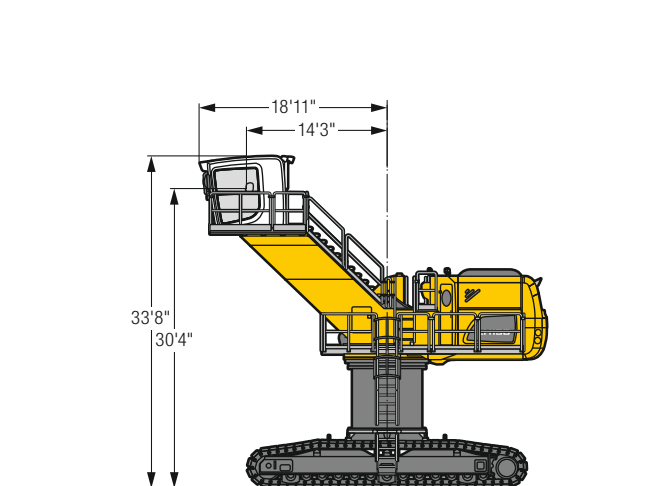

Cab elevation LHC-D 1090 T (hydraulic elevation)

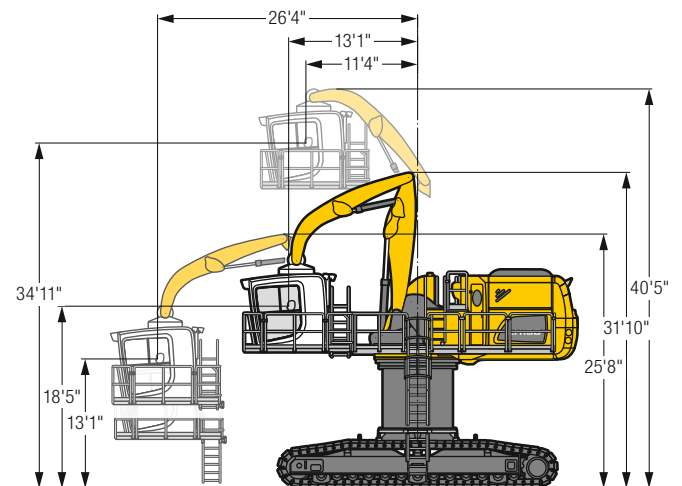

The hydraulically adjustable cab allows the driver, that he can choose his field of view freely and at any time within the stroke.

LH 150 C Gantry – Dimensions

Port

Cab elevation LFC 250

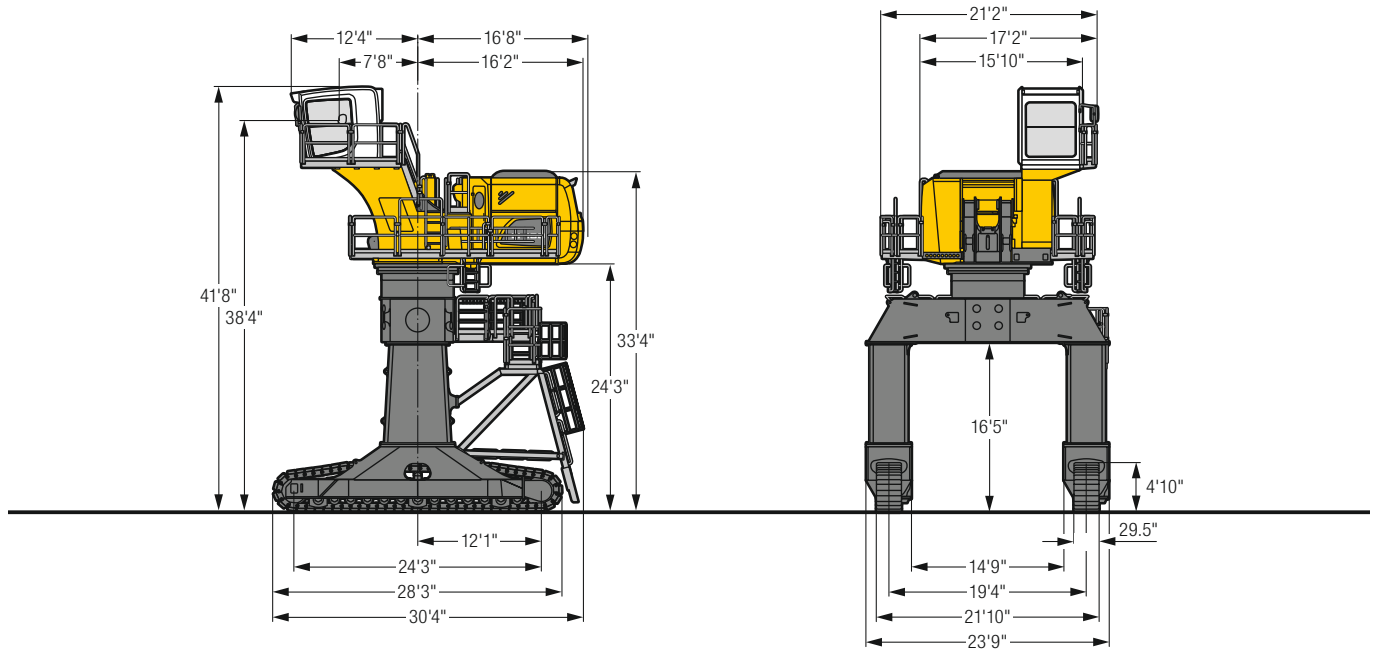

LH 150 C Gantry – Choice of cab elevation

Cab elevation LFC 350 (rigid elevation)

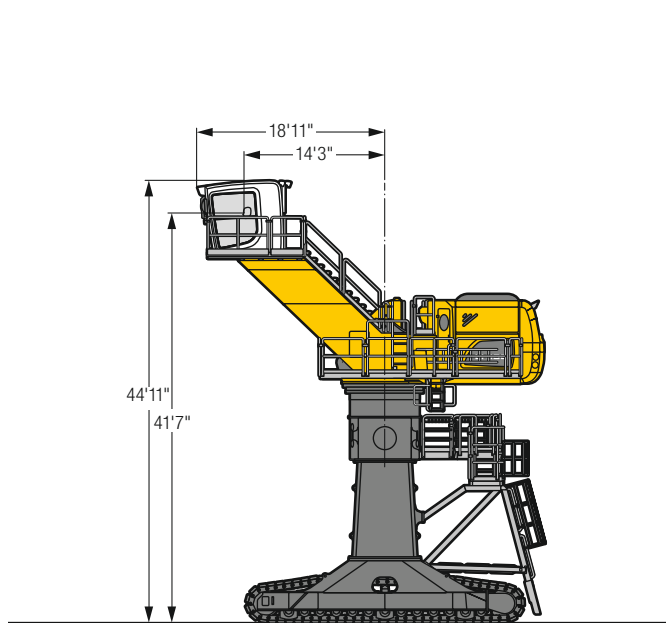

Cab elevation LHC-D 1090 T (hydraulic elevation)

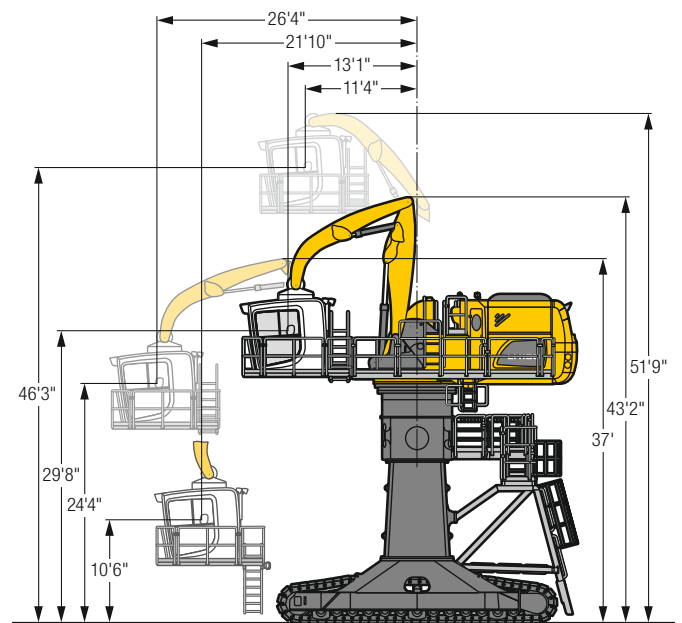

The hydraulically adjustable cab allows the driver, that he can choose his field of view freely and at any time within the stroke.

Kinematic variant 2A

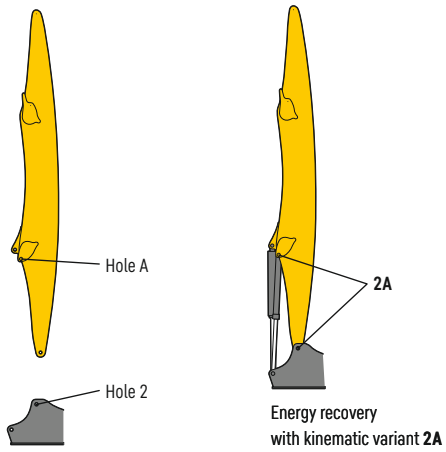

Kinematic variant 2D / 2C

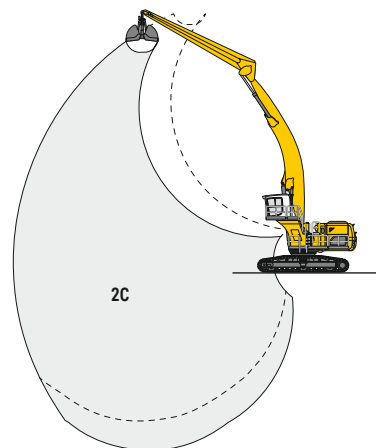
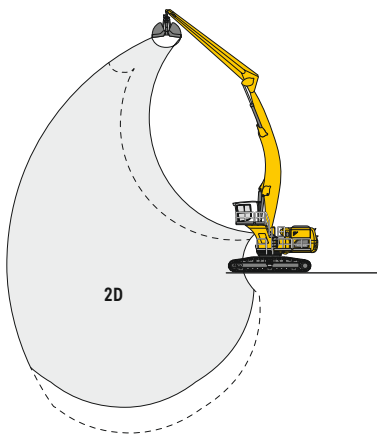
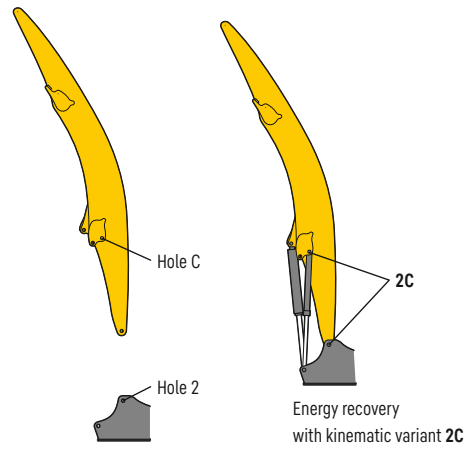
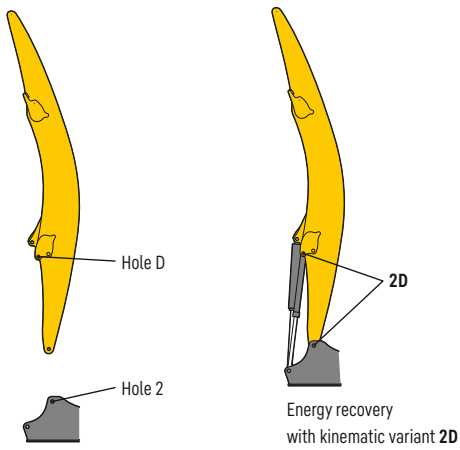

Altered range curve with additional reach depth, e.g. for unloading from ships

LH 150 M – Equipment AG24

Port – Kinematic 2D

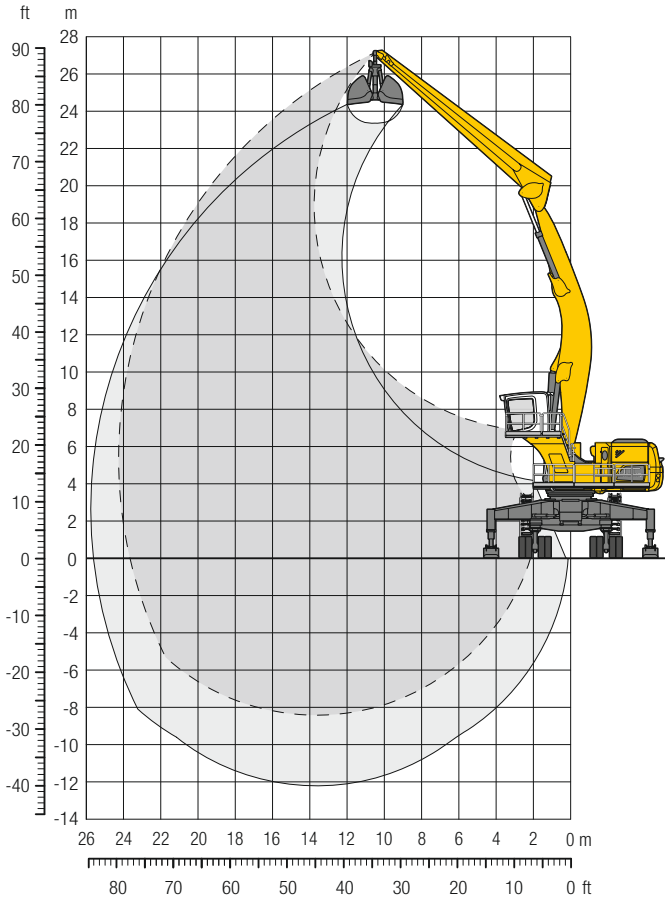

Dimensions

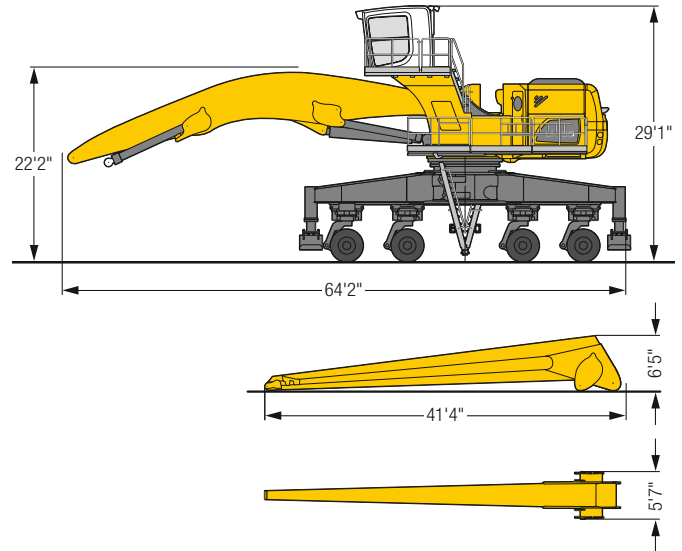

Operating weight

The operating weight includes the basic machine with 4 point outriggers, rigid cab elevation, 32 solid tires, angled boom 44'3", straight stick 39'4" and grab for loose material GMZ 120 / 10.46 yd³.

Weight	333,100 lb
--------	------------

ft	Undercarriage	20 ft		30 ft		40 ft		50 ft		60 ft		70 ft		80 ft		90 ft		100 ft		ft in			
		☞	☞	☞	☞	☞	☞	☞	☞	☞	☞	☞	☞	☞	☞	☞	☞	☞	☞	☞	☞	☞	
90	4 pt. outriggers down																				27,2*	27,2*	49' 4"
80	4 pt. outriggers down																				24,6*	24,6*	59' 10"
70	4 pt. outriggers down																				23,4*	23,4*	67' 2"
60	4 pt. outriggers down																				23,4*	23,4*	67' 2"
50	4 pt. outriggers down																				22,9*	22,9*	72' 6"
40	4 pt. outriggers down																				22,9*	22,9*	76' 1"
30	4 pt. outriggers down																				23,4*	23,4*	78' 4"
20	4 pt. outriggers down	99,3*	99,3*	65,9*	65,9*	50,0*	50,0*	40,8*	40,8*	34,7*	34,7*	30,3*	30,3*	28,3*	28,3*	29,1*	29,1*	29,1*	29,1*	24,4*	24,4*	79' 2"	
10	4 pt. outriggers down	49,4*	49,4*	72,8*	72,8*	53,7*	53,7*	42,9*	42,9*	35,8*	35,8*	30,7*	30,7*	30,5*	30,5*	30,5*	30,5*	30,5*	30,5*	25,9*	25,9*	78' 8"	
0	4 pt. outriggers down	36,8*	36,8*	76,5*	76,5*	56,1*	56,1*	44,2*	44,2*	36,4*	36,4*	30,5*	30,5*	30,5*	30,5*	30,5*	30,5*	30,5*	30,5*	26,3*	26,3*	77'	
-10	4 pt. outriggers down	38,4*	38,4*	74,6*	74,6*	56,0*	56,0*	43,9*	43,9*	35,6*	35,6*	28,5*	28,5*	28,5*	28,5*	28,5*	28,5*	28,5*	28,5*	25,4*	25,4*	73' 11"	
-20	4 pt. outriggers down																				25,9*	25,9*	66' 8"
-30	4 pt. outriggers down																				25,9*	25,9*	66' 8"

☞ Height ☞ Can be slewed through 360° ☞ In longitudinal position of undercarriage ☞ Max. reach * Limited by hydr. capacity

The lift capacities on the stick end without attachment are stated in lb x 1,000 and are valid on a firm, level supporting surface with blocked oscillating axle. These capacities can be slewed through 360° with the undercarriage in the transverse position. Capacities in the longitudinal position of the undercarriage (±15°) are specified over the rigid axle with the stabilizers down. Indicated loads based on the ISO 10567 standard and do not exceed 75% of tipping or 87% of hydraulic capacity. The lift capacity values indicated are attained at the corresponding operating temperature. This operating temperature is ensured by continuous movement of the boom. Weights of fitted attachments (grabs, load hooks, etc.) and load accommodation attachment are to be deducted from the lift capacity values. The lift capacity of the unit is limited by its stability, the lifting capability of the hydraulic elements, or the maximum permissible lifting capacity of the load hook.

LH 150 C HR – Equipment AG27

Port – Kinematic 2D

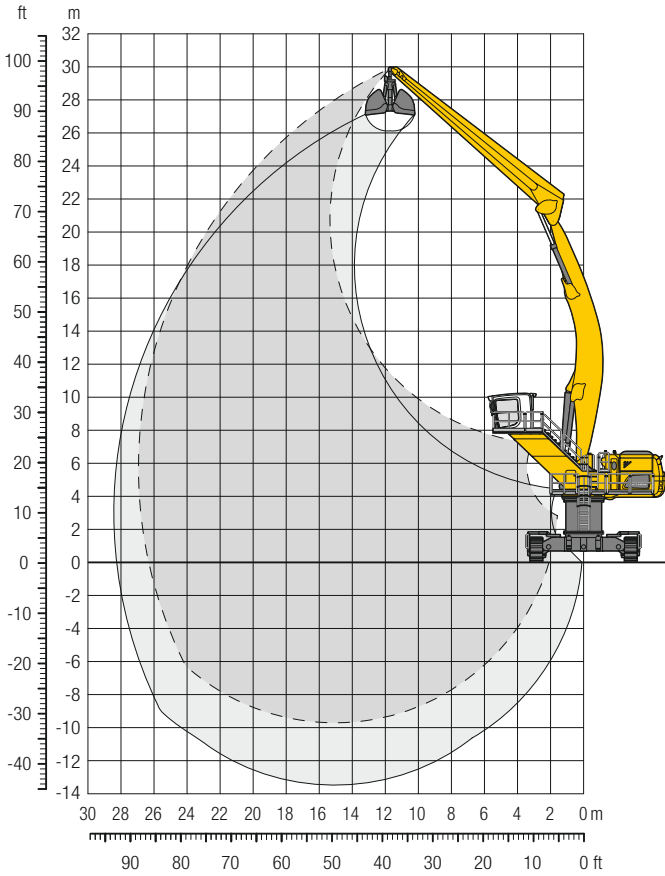

Dimensions

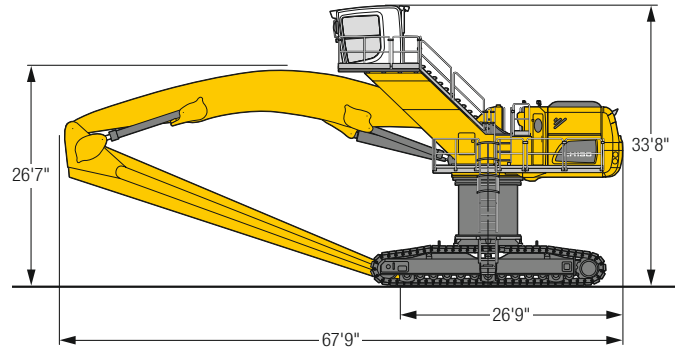

Operating weight and ground pressure

The operating weight includes the basic machine with turret 67", rigid cab elevation, angled boom 49'3", straight stick 44'3" and grab for loose material GMZ 120/10.46 yd³.

Weight	332,000 lb
Pad width	30"
Ground pressure	on request

ft	Undercarriage	20 ft		30 ft		40 ft		50 ft		60 ft		70 ft		80 ft		90 ft		100 ft		ft in		
		SW	SW	SW	SW	SW	SW	SW	SW	SW	SW	SW	SW	SW	SW	SW	SW	SW	SW	SW	SW	
90	SW							26,8*	26,8*											24,4*	24,4*	52'
80	SW							33,0*	33,0*	26,4*	26,4*									21,9*	21,9*	63' 7"
70	SW									28,5*	28,5*			23,5*	23,5*					20,6*	20,6*	71' 11"
60	SW							32,5*	32,5*	28,5*	28,5*	25,5*	25,5*							19,9*	19,9*	78' 1"
50	SW							33,2*	33,2*	28,9*	28,9*	25,7*	25,7*	23,3*	23,3*					19,7*	19,7*	82' 8"
40	SW							34,3*	34,3*	29,6*	29,6*	26,1*	26,1*	23,4*	23,4*					19,9*	19,9*	85' 10"
30	SW			56,7*	56,7*	43,9*	43,9*	35,9*	35,9*	30,5*	30,5*	26,7*	26,7*	23,7*	23,7*					20,3*	20,3*	87' 8"
20	SW	95,7*	95,7*	62,7*	62,7*	46,9*	46,9*	37,7*	37,7*	31,6*	31,6*	27,3*	27,3*	24,0*	24,0*					21,2*	21,2*	88' 5"
10	SW	36,1*	36,1*	67,9*	67,9*	49,8*	49,8*	39,4*	39,4*	32,6*	32,6*	27,9*	27,9*	24,1*	24,1*					21,3*	21,3*	87' 11"
0	SW	28,3*	28,3*	67,2*	67,2*	51,6*	51,6*	40,5*	40,5*	33,3*	33,3*	28,0*	28,0*	23,8*	23,8*					21,0*	21,0*	86' 4"
-10	SW	29,9*	29,9*	54,2*	54,2*	51,7*	51,7*	40,6*	40,6*	33,0*	33,0*	27,4*	27,4*	22,3*	22,3*					20,3*	20,3*	83' 6"
-20	SW	33,3*	33,3*	52,7*	52,7*	48,8*	48,8*	38,6*	38,6*	31,2*	31,2*	25,1*	25,1*							18,9*	18,9*	79' 4"
-30	SW					41,6*	41,6*	33,3*	33,3*	26,3*	26,3*									24,9*	24,9*	62' 2"

Height Can be slewed through 360° In longitudinal position of undercarriage Max. reach * Limited by hydr. capacity

The lift capacities on the stick end without attachment are stated in lb x 1,000 and can be slewed through 360° on a firm, level supporting surface. Capacities are valid for 30" wide flat pads. Indicated loads based on the ISO 10567 standard and do not exceed 75% of tipping or 87% of hydraulic capacity. The lift capacity values indicated are attained at the corresponding operating temperature. This operating temperature is ensured by continuous movement of the boom. Weights of fitted attachments (grabs, load hooks, etc.) and load accommodation attachment are to be deducted from the lift capacity values. The lift capacity of the unit is limited by its stability, the lifting capability of the hydraulic elements, or the maximum permissible lifting capacity of the load hook.

LH 150 M HR – Equipment AG30

Port – Kinematic 2D

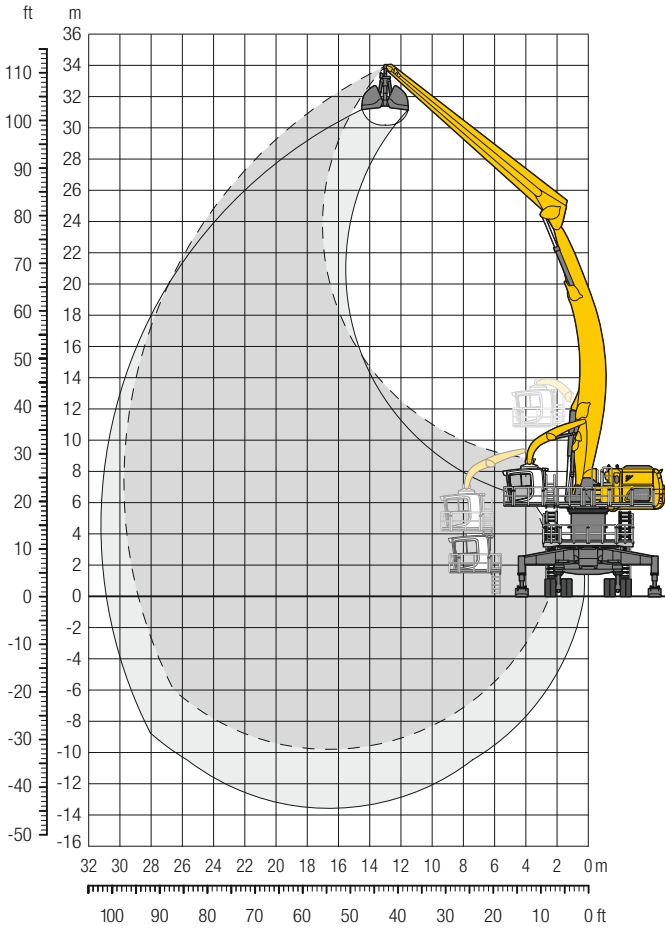

Dimensions

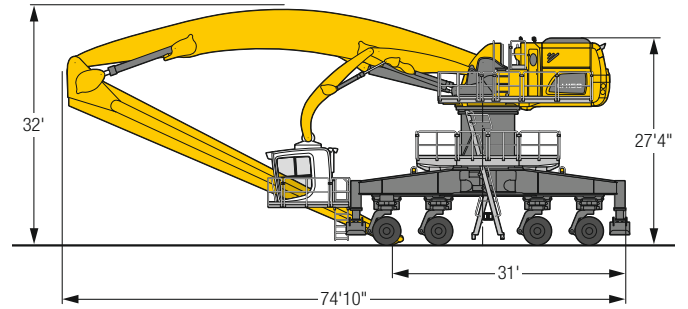

Operating weight

The operating weight includes the basic machine with 4 point outriggers, turret 6'7", hydr. cab elevation, 32 solid tires, angled boom 54'2", straight stick 49'3" and grab for loose material GMZ 120 / 10.46 yd³.

Weight 373,200 lb

ft	Undercarriage	20 ft		30 ft		40 ft		50 ft		60 ft		70 ft		80 ft		90 ft		100 ft		ft in		
		Can be slewed through 360°	In longitudinal position of undercarriage	Can be slewed through 360°	In longitudinal position of undercarriage	Can be slewed through 360°	In longitudinal position of undercarriage	Can be slewed through 360°	In longitudinal position of undercarriage	Can be slewed through 360°	In longitudinal position of undercarriage	Can be slewed through 360°	In longitudinal position of undercarriage	Can be slewed through 360°	In longitudinal position of undercarriage	Can be slewed through 360°	In longitudinal position of undercarriage	Can be slewed through 360°	In longitudinal position of undercarriage	Can be slewed through 360°	In longitudinal position of undercarriage	
110	4 pt. outriggers down																			23,8*	23,8*	47' 1"
100	4 pt. outriggers down									22,3*	22,3*									20,4*	20,4*	61' 11"
90	4 pt. outriggers down									26,6*	26,6*	21,4*	21,4*							18,7*	18,7*	72' 6"
80	4 pt. outriggers down									26,3*	26,3*	23,1*	23,1*	18,2*	18,2*					17,7*	17,7*	80' 5"
70	4 pt. outriggers down									26,4*	26,4*	23,0*	23,0*	20,5*	20,5*					17,2*	17,2*	86' 6"
60	4 pt. outriggers down									26,6*	26,6*	23,1*	23,1*	20,5*	20,5*	18,4*	18,4*			17,0*	17,0*	91'
50	4 pt. outriggers down							32,0*	32,0*	27,1*	27,1*	23,4*	23,4*	20,6*	20,6*	18,5*	18,5*			17,1*	17,1*	94' 4"
40	4 pt. outriggers down					40,9*	40,9*	33,0*	33,0*	27,7*	27,7*	23,8*	23,8*	20,9*	20,9*	18,5*	18,5*			17,2*	17,2*	96' 5"
30	4 pt. outriggers down	87,2*	87,2*	57,5*	57,5*	42,9*	42,9*	34,2*	34,2*	28,4*	28,4*	24,2*	24,2*	21,1*	21,1*	18,6*	18,6*			16,9*	16,9*	97' 6"
20	4 pt. outriggers down	41,0*	41,0*	61,2*	61,2*	44,8*	44,8*	35,3*	35,3*	29,1*	29,1*	24,7*	24,7*	21,3*	21,3*	18,6*	18,6*			16,7*	16,7*	97' 6"
10	4 pt. outriggers down	22,8*	22,8*	61,2*	61,2*	46,3*	46,3*	36,2*	36,2*	29,6*	29,6*	25,0*	25,0*	21,4*	21,4*	18,4*	18,4*			16,4*	16,4*	96' 5"
0	4 pt. outriggers down	22,7*	22,7*	43,4*	43,4*	46,9*	46,9*	36,6*	36,6*	29,8*	29,8*	24,9*	24,9*	21,1*	21,1*	17,6*	17,6*			15,9*	15,9*	94' 4"
-10	4 pt. outriggers down	25,3*	25,3*	40,4*	40,4*	45,7*	45,7*	35,9*	35,9*	29,2*	29,2*	24,2*	24,2*	20,0*	20,0*	15,7*	15,7*			15,2*	15,2*	91' 1"
-20	4 pt. outriggers down			41,3*	41,3*	41,9*	41,9*	33,4*	33,4*	27,1*	27,1*	22,1*	22,1*	17,4*	17,4*					14,3*	14,3*	85' 10"
-30	4 pt. outriggers down							28,2*	28,2*	22,7*	22,7*									19,7*	19,7*	65' 11"

Height Can be slewed through 360° In longitudinal position of undercarriage Max. reach * Limited by hydr. capacity

The lift capacities on the stick end without attachment are stated in lb x 1,000 and are valid on a firm, level supporting surface with blocked oscillating axle. These capacities can be slewed through 360° with the undercarriage in the transverse position. Capacities in the longitudinal position of the undercarriage (±15°) are specified over the rigid axle with the stabilizers down. Indicated loads based on the ISO 10567 standard and do not exceed 75% of tipping or 87% of hydraulic capacity. The lift capacity values indicated are attained at the corresponding operating temperature. This operating temperature is ensured by continuous movement of the boom. Weights of fitted attachments (grabs, load hooks, etc.) and load accommodation attachment are to be deducted from the lift capacity values. The lift capacity of the unit is limited by its stability, the lifting capability of the hydraulic elements, or the maximum permissible lifting capacity of the load hook.

LH 150 M Gantry – Equipment AG31

Port – Kinematic 2D

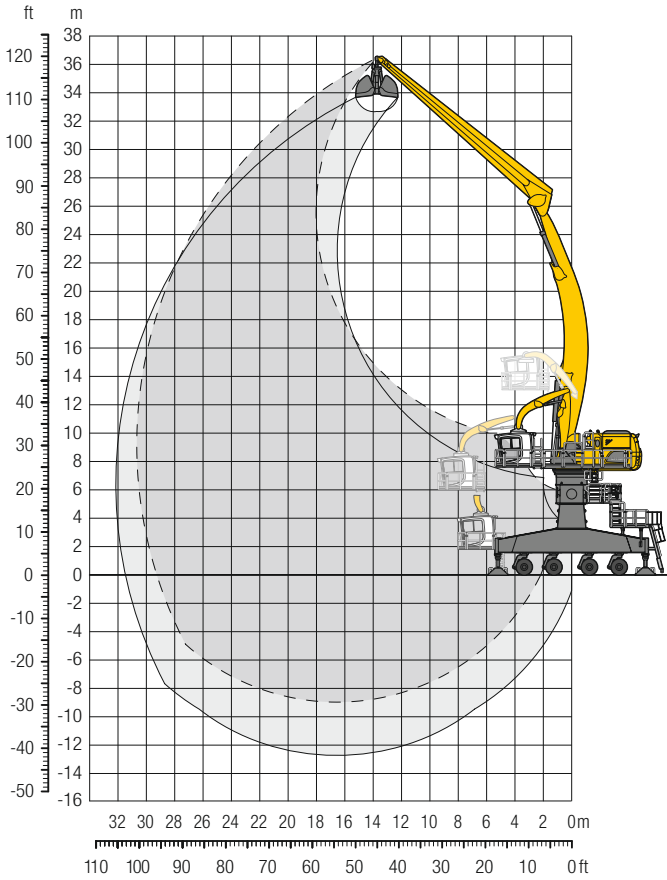

Dimensions

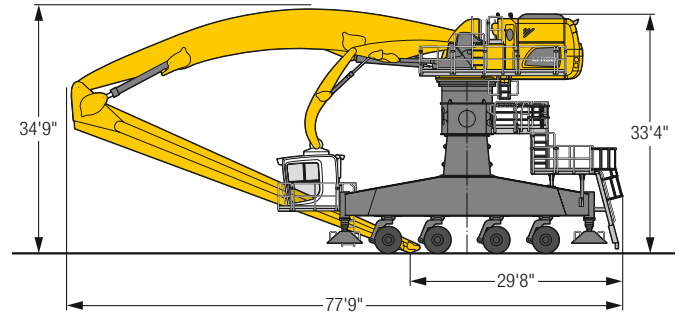

Operating weight

The operating weight includes the basic machine with 4 point outriggers, hydr. cab elevation, 32 solid tires 54'2", angled boom 54'2", straight stick 52'6" and grab for loose material GMZ 120 / 10.46 yd³.

Weight 388,000 lb

ft	Undercarriage	20 ft		30 ft		40 ft		50 ft		60 ft		70 ft		80 ft		90 ft		100 ft		Max. reach		ft in
		Can be slewed through 360°	In longitudinal position of undercarriage	Can be slewed through 360°	In longitudinal position of undercarriage	Can be slewed through 360°	In longitudinal position of undercarriage	Can be slewed through 360°	In longitudinal position of undercarriage	Can be slewed through 360°	In longitudinal position of undercarriage	Can be slewed through 360°	In longitudinal position of undercarriage	Can be slewed through 360°	In longitudinal position of undercarriage	Can be slewed through 360°	In longitudinal position of undercarriage	Can be slewed through 360°	In longitudinal position of undercarriage	Can be slewed through 360°	In longitudinal position of undercarriage	
110	4 pt. outriggers down									20,3*	20,3*									19,5*	19,5*	60' 10"
100	4 pt. outriggers down									26,3*	26,3*	19,8*	19,8*							17,7*	17,7*	72' 1"
90	4 pt. outriggers down									25,9*	25,9*	22,7*	22,7*	17,4*	17,4*					16,6*	16,6*	80' 8"
80	4 pt. outriggers down									25,8*	25,8*	22,6*	22,6*	20,1*	20,1*					16,0*	16,0*	87' 4"
70	4 pt. outriggers down									26,0*	26,0*	22,6*	22,6*	20,1*	20,1*	18,1*	18,1*			15,7*	15,7*	92' 4"
60	4 pt. outriggers down									26,3*	26,3*	22,9*	22,9*	20,2*	20,2*	18,1*	18,1*			15,7*	15,7*	96' 1"
50	4 pt. outriggers down									26,9*	26,9*	23,2*	23,2*	20,4*	20,4*	18,2*	18,2*			15,9*	15,9*	98' 7"
40	4 pt. outriggers down					41,0*	41,0*	33,0*	33,0*	27,6*	27,6*	23,6*	23,6*	20,7*	20,7*	18,3*	18,3*	16,3*	16,3*	16,3*	16,3*	100' 1"
30	4 pt. outriggers down	88,9*	88,9*	58,1*	58,1*	43,1*	43,1*	34,2*	34,2*	28,3*	28,3*	24,1*	24,1*	20,9*	20,9*	18,4*	18,4*	16,2*	16,2*	16,0*	16,0*	100' 7"
20	4 pt. outriggers down	35,1*	35,1*	61,5*	61,5*	44,9*	44,9*	35,3*	35,3*	29,0*	29,0*	24,5*	24,5*	21,2*	21,2*	18,5*	18,5*	15,8*	15,8*	15,8*	15,8*	100' 1"
10	4 pt. outriggers down	24,0*	24,0*	56,4*	56,4*	46,2*	46,2*	36,1*	36,1*	29,5*	29,5*	24,8*	24,8*	21,2*	21,2*	18,2*	18,2*			15,5*	15,5*	98' 7"
0	4 pt. outriggers down	24,2*	24,2*	43,2*	43,2*	46,5*	46,5*	36,3*	36,3*	29,5*	29,5*	24,6*	24,6*	20,8*	20,8*	17,4*	17,4*			15,1*	15,1*	96'
-10	4 pt. outriggers down	26,3*	26,3*	40,9*	40,9*	44,8*	44,8*	35,3*	35,3*	28,7*	28,7*	23,7*	23,7*	19,6*	19,6*	15,4*	15,4*			14,2*	14,2*	92' 2"
-20	4 pt. outriggers down			41,7*	41,7*	40,5*	40,5*	32,4*	32,4*	26,3*	26,3*	21,3*	21,3*	16,7*	16,7*					14,4*	14,4*	84' 5"
-30	4 pt. outriggers down																					

Height Can be slewed through 360° In longitudinal position of undercarriage Max. reach * Limited by hydr. capacity

The lift capacities on the stick end without attachment are stated in lb x 1,000 and are valid on a firm, level supporting surface with blocked oscillating axle. These capacities can be slewed through 360° with the undercarriage in the transverse position. Capacities in the longitudinal position of the undercarriage (±15°) are specified over the rigid axle with the stabilizers down. Indicated loads based on the ISO 10567 standard and do not exceed 75% of tipping or 87% of hydraulic capacity. The lift capacity values indicated are attained at the corresponding operating temperature. This operating temperature is ensured by continuous movement of the boom. Weights of fitted attachments (grabs, load hooks, etc.) and load accommodation attachment are to be deducted from the lift capacity values. The lift capacity of the unit is limited by its stability, the lifting capability of the hydraulic elements, or the maximum permissible lifting capacity of the load hook.

LH 150 M – Equipment GG17

Port – Kinematic 2A

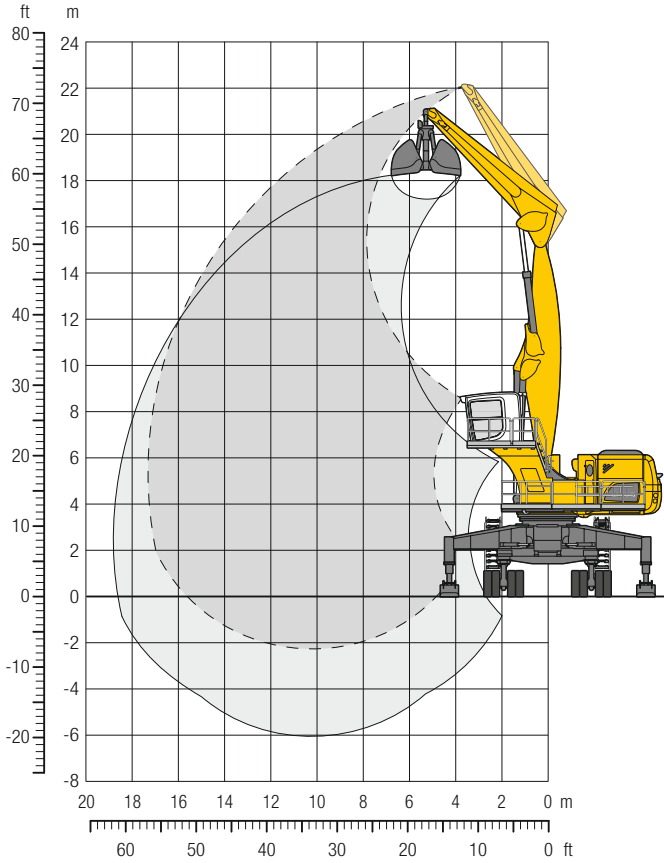

Dimensions

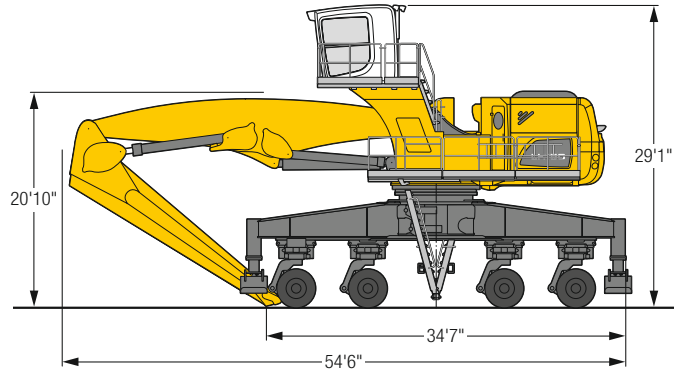

Operating weight

The operating weight includes the basic machine with 4 point outriggers, rigid cab elevation, 32 solid tires, straight boom 32'10", straight stick 24'7" and grab for loose material GMZ 120 / 10.46 yd³.

Weight 325,600 lb

ft	Undercarriage	20 ft		30 ft		40 ft		50 ft		60 ft		70 ft		80 ft		90 ft		100 ft		ft in		
70	4 pt. outriggers down	74,9*	74,9*																	66,1*	66,1*	22' 4"
60	4 pt. outriggers down			72,1*	72,1*															47,0*	47,0*	38' 1"
50	4 pt. outriggers down			69,8*	69,8*	59,3*	59,3*													41,2*	41,2*	46' 11"
40	4 pt. outriggers down			72,1*	72,1*	59,8*	59,8*	51,7*	51,7*											38,9*	38,9*	52' 4"
40	4 pt. outriggers down	106,6*	106,6*	78,3*	78,3*	62,4*	62,4*	52,0*	52,0*											38,4*	38,4*	55' 6"
30	4 pt. outriggers down	129,9*	129,9*	86,0*	86,0*	65,3*	65,3*	52,3*	52,3*											39,3*	39,3*	56' 8"
20	4 pt. outriggers down	66,1*	66,1*	89,9*	89,9*	66,1*	66,1*	50,1*	50,1*											37,8*	37,8*	56' 1"
10	4 pt. outriggers down	65,9*	65,9*	83,0*	83,0*	60,2*	60,2*	40,6*	40,6*											39,8*	39,8*	50' 4"
0	4 pt. outriggers down																					
-10	4 pt. outriggers down																					

Height Can be slewed through 360° In longitudinal position of undercarriage Max. reach * Limited by hydr. capacity

The lift capacities on the stick end without attachment are stated in lb x 1,000 and are valid on a firm, level supporting surface with blocked oscillating axle. These capacities can be slewed through 360° with the undercarriage in the transverse position. Capacities in the longitudinal position of the undercarriage (±15°) are specified over the rigid axle with the stabilizers down. Indicated loads based on the ISO 10567 standard and do not exceed 75% of tipping or 87% of hydraulic capacity. The lift capacity values indicated are attained at the corresponding operating temperature. This operating temperature is ensured by continuous movement of the boom. Weights of fitted attachments (grabs, load hooks, etc.) and load accommodation attachment are to be deducted from the lift capacity values. The lift capacity of the unit is limited by its stability, the lifting capability of the hydraulic elements, or the maximum permissible lifting capacity of the load hook.

LH 150 C – Equipment GG19

Port – Kinematic 2A

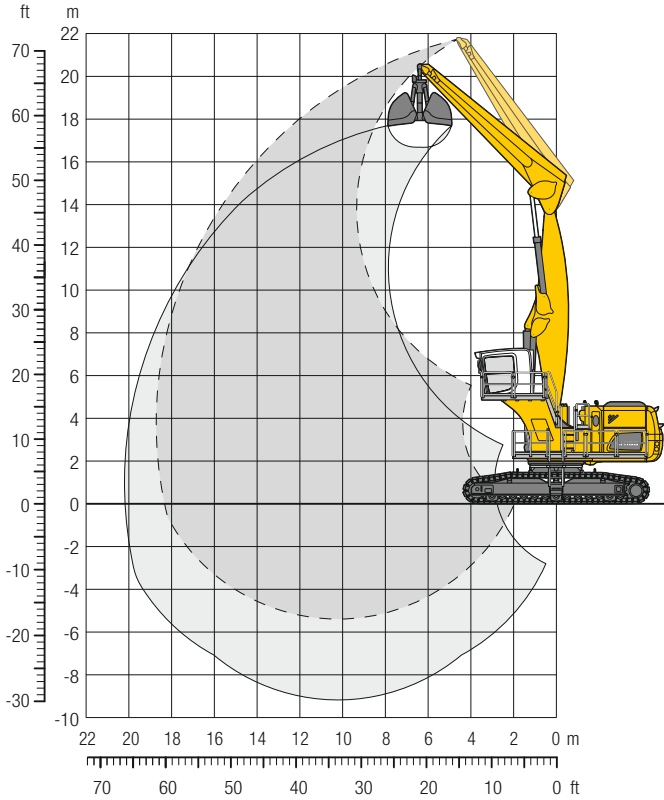

Dimensions

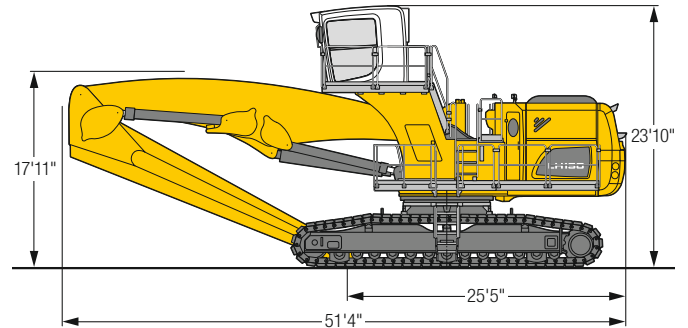

Operating weight and ground pressure

The operating weight includes the basic machine with rigid cab elevation, straight boom 32'10", straight stick 29'6" and grab for loose material GMZ 120 / 10.46 yd³.

Weight	304,500 lb
Pad width	30"
Ground pressure	on request

ft	Undercarriage	20 ft		30 ft		40 ft		50 ft		60 ft		70 ft		80 ft		90 ft		100 ft		ft in			
		SW	SW	SW	SW	SW	SW	SW	SW	SW	SW	SW	SW	SW	SW	SW	SW	SW	SW	SW	SW		
70	SW																				63,3*	63,3*	19'
60	SW																				41,5*	41,5*	37'11"
50	SW			61,2*	61,2*																56,7*	56,7*	48'
40	SW					56,2*	56,2*														50,1*	50,1*	54' 6"
40	SW			69,2*	69,2*	58,1*	58,1*	50,5*	50,5*												33,1*	33,1*	58' 7"
30	SW	84,4*	84,4*	76,9*	76,9*	61,7*	61,7*	51,9*	51,9*	36,9*	36,9*										32,3*	32,3*	60' 8"
20	SW	128,8*	128,8*	85,8*	85,8*	65,5*	65,5*	53,0*	53,0*	41,6*	41,6*										33,5*	33,5*	61' 2"
10	SW	82,4*	82,4*	90,7*	90,7*	67,0*	67,0*	51,8*	51,8*												35,2*	35,2*	59'11"
0	SW	72,3*	72,3*	85,2*	85,2*	62,1*	62,1*	44,6*	44,6*												38,1*	38,1*	53' 4"
-10	SW																						

Height Can be slewed through 360° In longitudinal position of undercarriage Max. reach * Limited by hydr. capacity

The lift capacities on the stick end without attachment are stated in lb x 1,000 and can be slewed through 360° on a firm, level supporting surface. Capacities are valid for 30" wide flat pads. Indicated loads based on the ISO 10567 standard and do not exceed 75% of tipping or 87% of hydraulic capacity. The lift capacity values indicated are attained at the corresponding operating temperature. This operating temperature is ensured by continuous movement of the boom. Weights of fitted attachments (grabs, load hooks, etc.) and load accommodation attachment are to be deducted from the lift capacity values. The lift capacity of the unit is limited by its stability, the lifting capability of the hydraulic elements, or the maximum permissible lifting capacity of the load hook.

LH 150 M HR – Equipment GG25

Port – Kinematic 2A

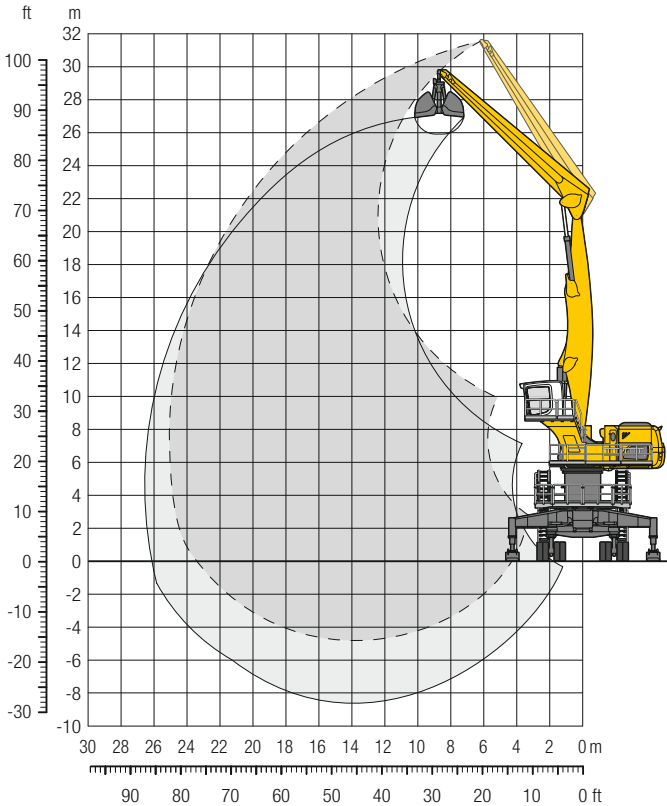

Dimensions

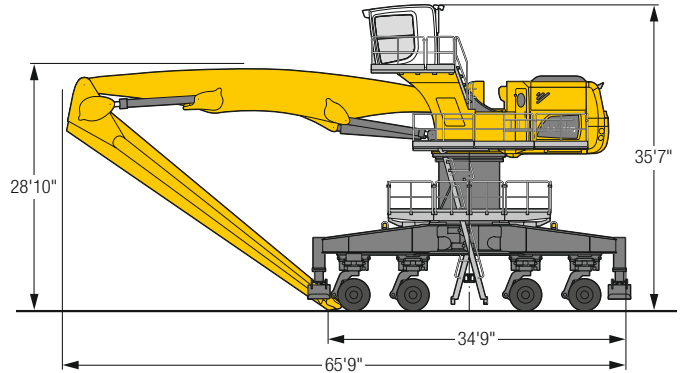

Operating weight

The operating weight includes the basic machine with 4 point outriggers, turret 6'7", rigid cab elevation, 32 solid tires, straight boom 44'3", straight stick 39'4" and grab for loose material GMZ 120/10.46 yd³.

Weight 354,900 lb

ft	Undercarriage	20 ft		30 ft		40 ft		50 ft		60 ft		70 ft		80 ft		90 ft		100 ft		ft in		
		ft	in	ft	in	ft	in	ft	in	ft	in	ft	in	ft	in	ft	in	ft	in	ft	in	
100	4 pt. outriggers down			43,1*	43,1*															40,5*	40,5*	31' 6"
90	4 pt. outriggers down					43,6*	43,6*													30,4*	30,4*	49' 2"
80	4 pt. outriggers down					48,0*	48,0*	41,0*	41,0*	27,2*	27,2*									26,5*	26,5*	60' 4"
70	4 pt. outriggers down							40,3*	40,3*	35,4*	35,4*									24,5*	24,5*	68' 2"
60	4 pt. outriggers down					47,6*	47,6*	40,4*	40,4*	35,3*	35,3*	31,3*	31,3*							23,4*	23,4*	73' 11"
50	4 pt. outriggers down					49,0*	49,0*	41,2*	41,2*	35,6*	35,6*	31,3*	31,3*							22,9*	22,9*	77' 11"
40	4 pt. outriggers down			58,5*	58,5*	51,5*	51,5*	42,5*	42,5*	36,3*	36,3*	31,5*	31,5*	24,4*	24,4*					22,9*	22,9*	80' 5"
30	4 pt. outriggers down	89,9*	89,9*	71,6*	71,6*	54,4*	54,4*	44,0*	44,0*	37,0*	37,0*	31,6*	31,6*	26,3*	26,3*					23,3*	23,3*	81' 8"
20	4 pt. outriggers down	46,2*	46,2*	77,0*	77,0*	57,0*	57,0*	45,3*	45,3*	37,4*	37,4*	31,3*	31,3*	24,8*	24,8*					23,1*	23,1*	81' 8"
10	4 pt. outriggers down	27,2*	27,2*	78,5*	78,5*	57,8*	57,8*	45,4*	45,4*	36,8*	36,8*	29,9*	29,9*	21,2*	21,2*					20,5*	20,5*	80' 6"
0	4 pt. outriggers down	30,6*	30,6*	70,6*	70,6*	55,3*	55,3*	43,2*	43,2*	34,3*	34,3*	26,2*	26,2*							20,1*	20,1*	75' 11"
-10	4 pt. outriggers down			60,1*	60,1*	47,3*	47,3*	37,0*	37,0*	28,1*	28,1*									24,3*	24,3*	64' 2"
-20	4 pt. outriggers down																					

Height Can be slewed through 360° In longitudinal position of undercarriage Max. reach * Limited by hydr. capacity

The lift capacities on the stick end without attachment are stated in lb x 1,000 and are valid on a firm, level supporting surface with blocked oscillating axle. These capacities can be slewed through 360° with the undercarriage in the transverse position. Capacities in the longitudinal position of the undercarriage (±15°) are specified over the rigid axle with the stabilizers down. Indicated loads based on the ISO 10567 standard and do not exceed 75% of tipping or 87% of hydraulic capacity. The lift capacity values indicated are attained at the corresponding operating temperature. This operating temperature is ensured by continuous movement of the boom. Weights of fitted attachments (grabs, load hooks, etc.) and load accommodation attachment are to be deducted from the lift capacity values. The lift capacity of the unit is limited by its stability, the lifting capability of the hydraulic elements, or the maximum permissible lifting capacity of the load hook.

LH 150 C HR – Equipment GG28

Port – Kinematic 2A

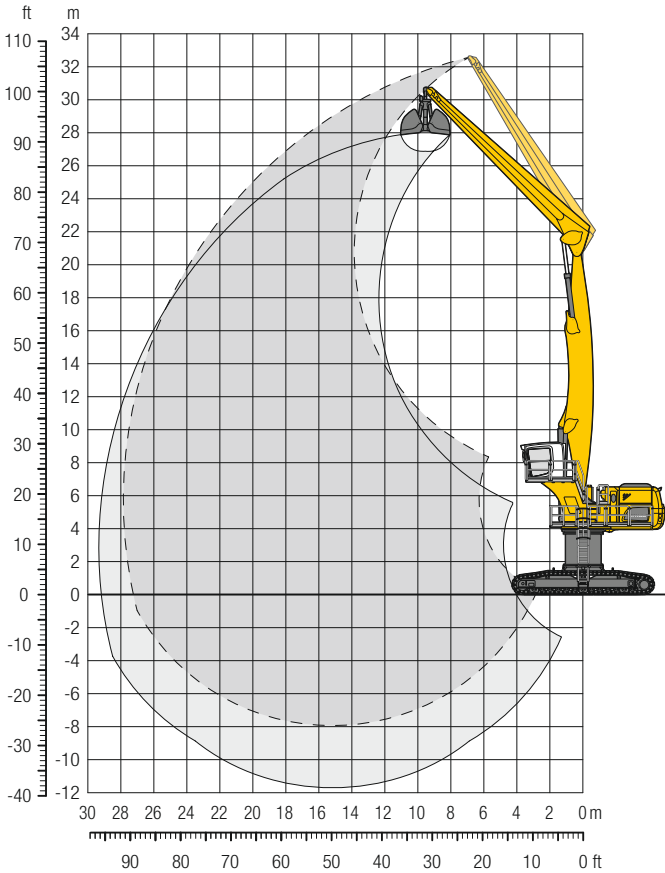

Dimensions

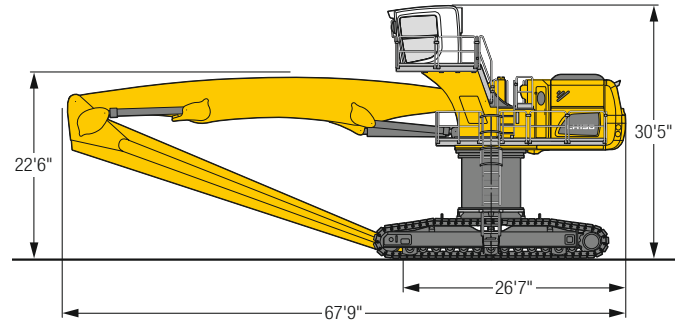

Operating weight and ground pressure

The operating weight includes the basic machine with turret 67", rigid cab elevation, straight boom 49'3", straight stick 44'3" and grab for loose material GMZ 120 / 10.46 yd³.

Weight	328,700 lb
Pad width	30"
Ground pressure	on request

ft	Undercarriage	20 ft		30 ft		40 ft		50 ft		60 ft		70 ft		80 ft		90 ft		100 ft		ft in		
		SW	SW	SW	SW	SW	SW	SW	SW	SW	SW	SW	SW	SW	SW	SW	SW	SW	SW	SW	SW	
100	SW					33,8*	33,8*													32,1*	32,1*	41' 2"
90	SW					42,1*	42,1*	34,8*	34,8*											25,8*	25,8*	56' 11"
80	SW							38,5*	38,5*	33,2*	33,2*									22,9*	22,9*	67' 8"
70	SW							38,0*	38,0*	32,8*	32,8*	28,9*	28,9*							21,3*	21,3*	75' 7"
60	SW							38,0*	38,0*	32,7*	32,7*	28,7*	28,7*	23,7*	23,7*					20,3*	20,3*	81' 6"
50	SW							38,6*	38,6*	33,0*	33,0*	28,8*	28,8*	25,4*	25,4*					19,9*	19,9*	85' 11"
40	SW					48,1*	48,1*	39,5*	39,5*	33,5*	33,5*	29,0*	29,0*	25,4*	25,4*					19,7*	19,7*	88' 11"
30	SW			56,9*	56,9*	50,3*	50,3*	40,7*	40,7*	34,1*	34,1*	29,3*	29,3*	25,3*	25,3*	21,2*	21,2*			19,9*	19,9*	90' 8"
20	SW			70,7*	70,7*	52,6*	52,6*	41,8*	41,8*	34,7*	34,7*	29,4*	29,4*	25,1*	25,1*	20,4*	20,4*			19,4*	19,4*	91' 5"
10	SW	21,8*	21,8*	73,6*	73,6*	54,1*	54,1*	42,5*	42,5*	34,8*	34,8*	29,2*	29,2*	24,3*	24,3*	18,6*	18,6*			17,7*	17,7*	90' 11"
0	SW	20,0*	20,0*	55,5*	55,5*	53,8*	53,8*	42,1*	42,1*	34,2*	34,2*	28,1*	28,1*	22,6*	22,6*					15,4*	15,4*	89' 5"
-10	SW	24,3*	24,3*	47,9*	47,9*	50,4*	50,4*	39,7*	39,7*	31,9*	31,9*	25,5*	25,5*	19,0*	19,0*					15,5*	15,5*	84'
-20	SW			49,7*	49,7*	42,5*	42,5*	34,1*	34,1*	26,9*	26,9*	20,2*	20,2*							18,6*	18,6*	72' 2"

Height Can be slewed through 360° In longitudinal position of undercarriage Max. reach * Limited by hydr. capacity

The lift capacities on the stick end without attachment are stated in lb x 1,000 and can be slewed through 360° on a firm, level supporting surface. Capacities are valid for 30" wide flat pads. Indicated loads based on the ISO 10567 standard and do not exceed 75% of tipping or 87% of hydraulic capacity. The lift capacity values indicated are attained at the corresponding operating temperature. This operating temperature is ensured by continuous movement of the boom. Weights of fitted attachments (grabs, load hooks, etc.) and load accommodation attachment are to be deducted from the lift capacity values. The lift capacity of the unit is limited by its stability, the lifting capability of the hydraulic elements, or the maximum permissible lifting capacity of the load hook.

LH 150 C Gantry – Equipment GG31

Port – Kinematic 2A

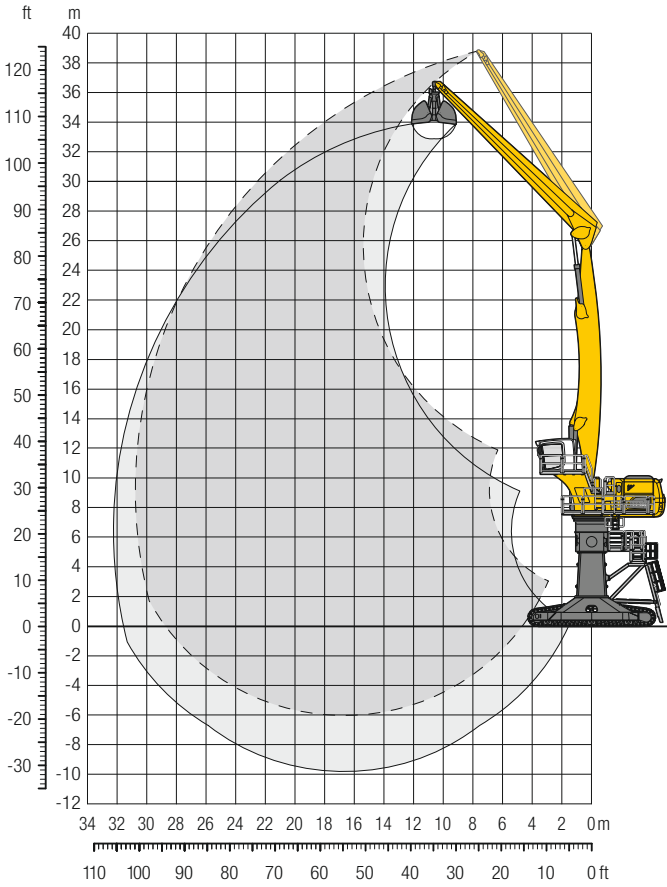

Dimensions

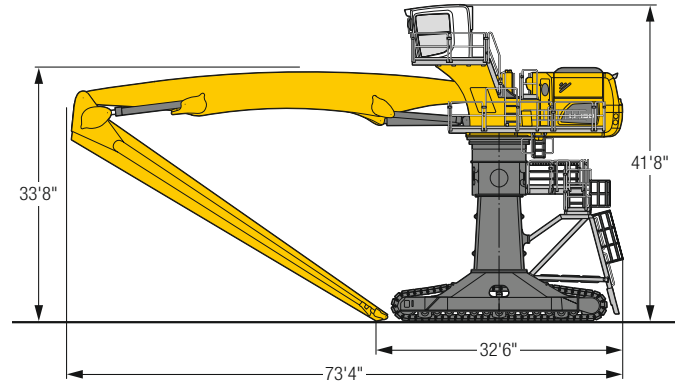

Operating weight and ground pressure

The operating weight includes the basic machine with rigid cab elevation, straight boom 54'2", straight stick 49'3" and grab for loose material GMZ 120 / 10.46 yd³.

Weight	355,400 lb
Pad width	30"
Ground pressure	on request

ft	Undercarriage	20 ft		30 ft		40 ft		50 ft		60 ft		70 ft		80 ft		90 ft		100 ft		ft in			
		ft	in	ft	in	ft	in	ft	in	ft	in	ft	in	ft	in	ft	in	ft	in	ft	in		
130	Gantry																						
120	Gantry					33,7*	33,7*														28,4*	28,4*	45'
110	Gantry							33,5*	33,5*	24,7*	24,7*										23,0*	23,0*	61' 2"
100	Gantry							36,9*	36,9*	31,1*	31,1*	23,9*	23,9*								20,4*	20,4*	72' 6"
90	Gantry									30,8*	30,8*	26,6*	26,6*	20,6*	20,6*						18,8*	18,8*	81'
80	Gantry									30,7*	30,7*	26,5*	26,5*	23,1*	23,1*						17,9*	17,9*	87' 7"
70	Gantry									30,8*	30,8*	26,5*	26,5*	23,1*	23,1*	20,1*	20,1*				17,4*	17,4*	92' 7"
60	Gantry									37,1*	37,1*	31,0*	31,0*	26,6*	26,6*	23,1*	23,1*	20,1*	20,1*		17,1*	17,1*	96' 4"
50	Gantry									37,7*	37,7*	31,4*	31,4*	26,7*	26,7*	23,1*	23,1*	20,0*	20,0*		17,0*	17,0*	98' 11"
40	Gantry																				16,2*	16,2*	100' 5"
30	Gantry																				15,9*	15,9*	100' 11"
20	Gantry																				14,7*	14,7*	100' 5"
10	Gantry																				13,3*	13,3*	98' 10"
0	Gantry	14,7*	14,7*																		13,3*	13,3*	94' 2"
-10	Gantry	18,6*	18,6*																		12,6*	12,6*	84' 2"
-20	Gantry																						

Height Can be slewed through 360° In longitudinal position of undercarriage Max. reach * Limited by hydr. capacity

The lift capacities on the stick end without attachment are stated in lb x 1,000 and can be slewed through 360° on a firm, level supporting surface. Capacities are valid for 30" wide flat pads. Indicated loads based on the ISO 10567 standard and do not exceed 75% of tipping or 87% of hydraulic capacity. The lift capacity values indicated are attained at the corresponding operating temperature. This operating temperature is ensured by continuous movement of the boom. Weights of fitted attachments (grabs, load hooks, etc.) and load accommodation attachment are to be deducted from the lift capacity values. The lift capacity of the unit is limited by its stability, the lifting capability of the hydraulic elements, or the maximum permissible lifting capacity of the load hook.

LH 150 M Gantry – Equipment GG32

Port – Kinematic 2A

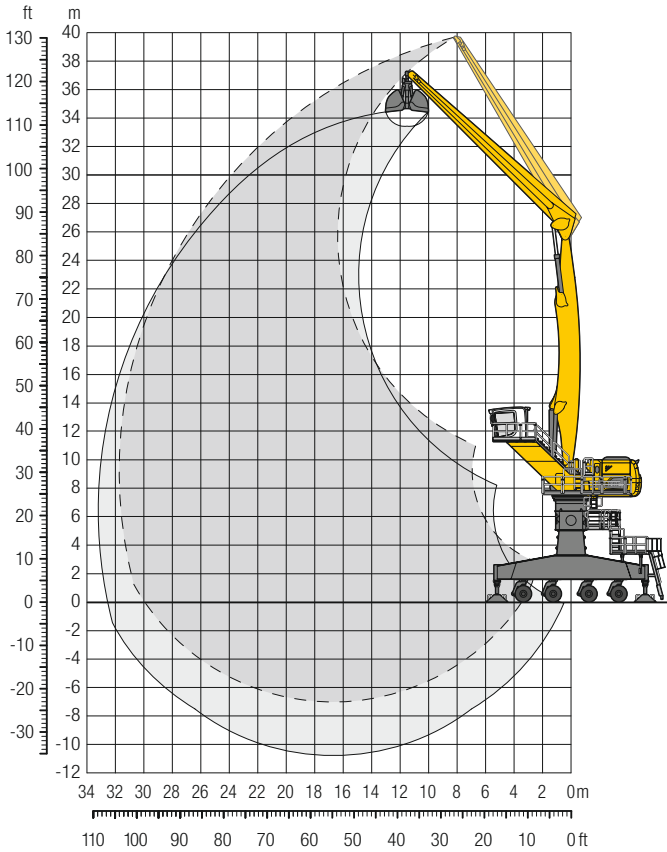

Dimensions

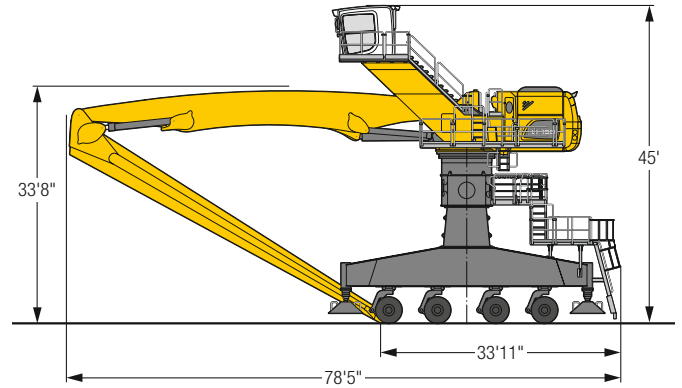

Operating weight

The operating weight includes the basic machine with 4 point outriggers, rigid cab elevation, 32 solid tires, straight boom 54'2", straight stick 52'6" and grab for loose material GMZ 120 / 10.46 yd³.

Weight 377,700 lb

ft	Undercarriage	20 ft		30 ft		40 ft		50 ft		60 ft		70 ft		80 ft		90 ft		100 ft		ft in			
		☞	☞	☞	☞	☞	☞	☞	☞	☞	☞	☞	☞	☞	☞	☞	☞	☞	☞	☞	☞	☞	
130	4 pt. outriggers down																				36,7*	36,7*	27' 5"
120	4 pt. outriggers down																				24,7*	24,7*	51'10"
110	4 pt. outriggers down					34,6*	34,6*	26,7*	26,7*												20,7*	20,7*	66' 4"
100	4 pt. outriggers down							33,3*	33,3*	27,2*	27,2*										18,5*	18,5*	76'11"
90	4 pt. outriggers down									30,7*	30,7*	26,0*	26,0*								17,2*	17,2*	84'11"
80	4 pt. outriggers down									30,4*	30,4*	26,2*	26,2*	23,0*	23,0*						16,4*	16,4*	91' 2"
70	4 pt. outriggers down									30,3*	30,3*	26,1*	26,1*	22,9*	22,9*	18,5*	18,5*				15,7*	15,7*	99' 7"
60	4 pt. outriggers down									30,4*	30,4*	26,2*	26,2*	22,8*	22,8*	20,0*	20,0*				16,0*	16,0*	96' 1"
50	4 pt. outriggers down							36,5*	36,5*	30,7*	30,7*	26,3*	26,3*	22,8*	22,8*	20,0*	20,0*				15,7*	15,7*	99' 7"
40	4 pt. outriggers down							37,2*	37,2*	31,0*	31,0*	26,4*	26,4*	22,9*	22,9*	19,9*	19,9*	17,0*	17,0*		15,7*	15,7*	102' 1"
30	4 pt. outriggers down			39,2*	39,2*	47,6*	47,6*	38,0*	38,0*	31,4*	31,4*	26,6*	26,6*	22,9*	22,9*	19,8*	19,8*	16,7*	16,7*		15,2*	15,2*	103' 7"
20	4 pt. outriggers down			66,4*	66,4*	49,0*	49,0*	38,6*	38,6*	31,7*	31,7*	26,7*	26,7*	22,8*	22,8*	19,5*	19,5*	16,1*	16,1*		14,1*	14,1*	104' 1"
10	4 pt. outriggers down			68,0*	68,0*	49,7*	49,7*	38,9*	38,9*	31,7*	31,7*	26,5*	26,5*	22,4*	22,4*	18,9*	18,9*	14,9*	14,9*		12,8*	12,8*	103' 7"
0	4 pt. outriggers down	15,9*	15,9*	44,3*	44,3*	49,3*	49,3*	38,5*	38,5*	31,3*	31,3*	25,9*	25,9*	21,6*	21,6*	17,7*	17,7*	12,7*	12,7*		11,1*	11,1*	102' 1"
-10	4 pt. outriggers down	18,6*	18,6*	36,5*	36,5*	46,8*	46,8*	36,9*	36,9*	29,8*	29,8*	24,4*	24,4*	19,9*	19,9*	15,4*	15,4*				10,1*	10,1*	98' 2"
-20	4 pt. outriggers down			36,9*	36,9*	41,3*	41,3*	33,1*	33,1*	26,8*	26,8*	21,5*	21,5*	16,7*	16,7*						11,5*	11,5*	89' 5"
						31,7*	31,7*	26,2*	26,2*	21,1*	21,1*	16,3*	16,3*								15,1*	15,1*	72' 5"

☞ Height ☞ Can be slewed through 360° ☞ In longitudinal position of undercarriage ☞ Max. reach * Limited by hydr. capacity

The lift capacities on the stick end without attachment are stated in lb x 1,000 and are valid on a firm, level supporting surface with blocked oscillating axle. These capacities can be slewed through 360° with the undercarriage in the transverse position. Capacities in the longitudinal position of the undercarriage (±15°) are specified over the rigid axle with the stabilizers down. Indicated loads based on the ISO 10567 standard and do not exceed 75% of tipping or 87% of hydraulic capacity. The lift capacity values indicated are attained at the corresponding operating temperature. This operating temperature is ensured by continuous movement of the boom. Weights of fitted attachments (grabs, load hooks, etc.) and load accommodation attachment are to be deducted from the lift capacity values. The lift capacity of the unit is limited by its stability, the lifting capability of the hydraulic elements, or the maximum permissible lifting capacity of the load hook.

Attachments

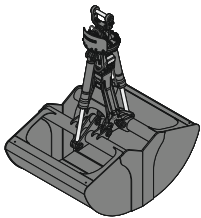

Grab for loose material

Shells for loose material with cutting edge (without teeth)

Grab model GMZ 120								
Width of shells	ft in	5'3"	5'11"	6'7"	7'3"	7'10"	9'2"	10'6"
Capacity	yd ³	5.23	5.88	6.54	7.19	7.85	9.15	10.46
Weight	lb	6,625	6,925	7,230	8,005	8,320	8,910	9,545

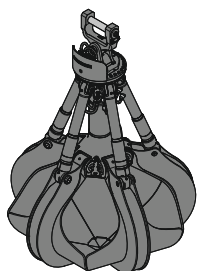

Multi-tine grab

closed, heart-shaped

Grab model GMM 120-5 (5 tines)					
Capacity	yd ³	2.22	2.62	3.27	3.92
Weight	lb	6,550	6,855	7,200	8,090

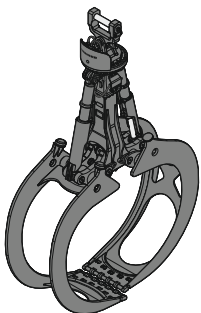

Wood grab

Grab model GMH 120 round-shaped (complete overlapping, vertical cylinders)			
Size	yd ²	3.35	3.83
Cutting width	ft in	2'10"	2'10"
Height of grab, closed	ft in	11'9"	12'1"
Weight	lb	6,110	6,175
Grab model GMH 120 round-shaped (complete overlapping, straight design, vertical cylinders, two over one grab)			
Size	yd ²	1.67	
Cutting width	ft in	2'10"	
Height of grab, closed	ft in	9'8"	
Weight	lb	5,710	



Load hook

Max. load	lb	55,115
Weight	lb	562

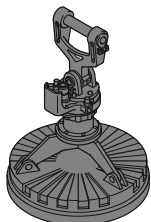

Magnet devices / lifting magnets

Generator	kW	30
Electromagnet with suspension		
Power	kW	22
Diameter of magnet	ft in	6'3"
Weight	lb	11,220

Liebherr ERC-System

More performance, less consumption

Lowering the equipment stores energy in the ERC-System. This stored energy is then made available to the machine to provide additional engine power. When the equipment is raised the stored energy is released and is reflected in powerful, homogeneous operating cycles. The result is a clear saving on fuel – and, at the same time, even greater performance.

System performance

The energy recovery cylinder is a storage system which is independent of the diesel engine. The system performance of material handling machines fitted with the ERC-System is composed of the installed engine power and the energy recovery cylinder. When the equipment is raised, energy from the ERC-System is supplied in addition to the power from the diesel engine.

ERC-System

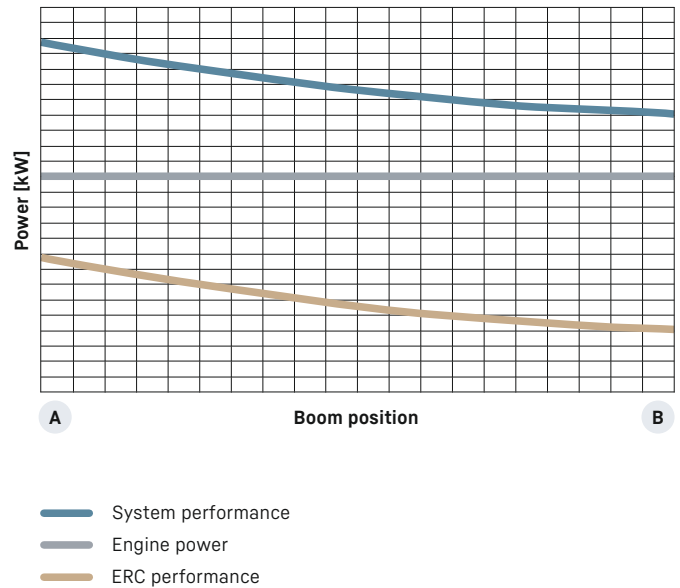

B 1. Equipment fitting raised / energy released



2. Lower equipment fitting / store energy
4. Raise equipment fitting / release energy



A 3. Equipment fitting lowered / energy stored

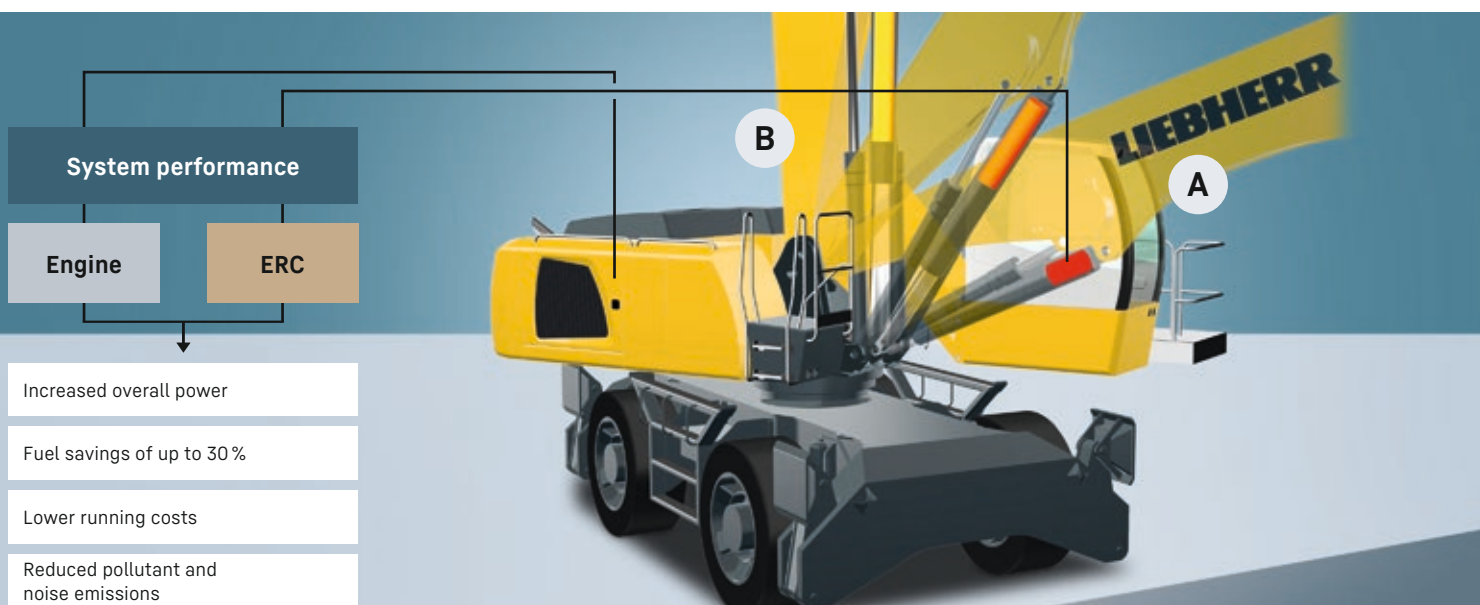

Equipment



Undercarriage

	150 M	150 C	150 M HR	150 C HR	150 M Gantry	150 C Gantry
6 steering axles, 2 powered and braked	●					
8 steering axles, 2 powered and braked	+		+		●	
Support plates, variants	+		+		+	
Axle load monitoring	●		●		●	
Working lights on undercarriage, LED	●		●		●	
Track pads, variants		+		+		+
Individual control outriggers	●		●		●	
Three-piece chain guide		●		●		●
Outrigger monitoring system	●		●		●	
Tires, variants	+		+		+	
Warning beacons	●		●		●	



Uppercarriage

	150 M	150 C	150 M HR	150 C HR	150 M Gantry	150 C Gantry
Tank refilling pump fuel	+	+	+	+	+	+
Generator	+	+	+	+	+	+
Main battery switch for electrical system	●	●	●	●	●	●
Engine hood, hydraulic operable	●	●	●	●	●	●
Walk-in engine bay	●	●	●	●	●	●
Amber beacon, at uppercarriage, LED double flash	+	+	+	+	+	+
Side hood on the right, hydraulic operable	●	●	●	●	●	●
Tool equipment, extended	●	●	●	●	●	●



Hydraulic system

	150 M	150 C	150 M HR	150 C HR	150 M Gantry	150 C Gantry
Shut-off valve between hydraulic tank and pump(s)	●	●	●	●	●	●
Pressure test fittings	●	●	●	●	●	●
Accumulator for controlled lowering of the equipment with the engine shut down	●	●	●	●	●	●
Electronic pump regulation	●	●	●	●	●	●
Hydraulic oil filter with integrated microfilter	●	●	●	●	●	●
Liebherr hydraulic oil from -4°F to +104°F	●	●	●	●	●	●
Liebherr hydraulic oil, biologically degradable	+	+	+	+	+	+
Liebherr hydraulic oil, specially for warm or cold regions	+	+	+	+	+	+
Magnetic rod in hydraulic tank	●	●	●	●	●	●
Bypass filter	+	+	+	+	+	+
Preheating hydraulic oil	+	+	+	+	+	+



Engine

	150 M	150 C	150 M HR	150 C HR	150 M Gantry	150 C Gantry
Air pre-filter with dust discharge	+	+	+	+	+	+
Preheating fuel	+	+	+	+	+	+
Preheating coolant	+	+	+	+	+	+
Preheating engine oil*	+	+	+	+	+	+



Cooling system

	150 M	150 C	150 M HR	150 C HR	150 M Gantry	150 C Gantry
Reversible fan drive	+	+	+	+	+	+



Cab

	150 M	150 C	150 M HR	150 C HR	150 M Gantry	150 C Gantry
Cab lights rear, LED	•	•	•	•	•	•
Cab lights front, LED (under rain cover)	•	•	•	•	•	•
Armrest adjustable	•	•	•	•	•	•
Circular bubble level	•	•	•	•	•	•
Slewing gear brake Comfort, button on the left or right joystick	+ +	+ +	+ +	+ +	+ +	+ +
Driver profile, personalized (max. 5 drivers)	+ +	+ +	+ +	+ +	+ +	+ +
Operator's seat Comfort	•	•	•	•	•	•
Operator's seat Premium	+ +	+ +	+ +	+ +	+ +	+ +
Driving alarm (acoustic signal is emitted during travel, can not be switched ON / OFF)	+ +	+ +	+ +	+ +	+ +	+ +
Fire extinguisher	•	•	•	•	•	•
Cab elevation, hydraulic with double parallelogram (LHC-D)	+ +	+ +	+ +	+ +	+ +	+ +
Cab elevation, rigid (LFC)	•	•	•	•	•	•
Automatic air conditioning	•	•	•	•	•	•
Electric cooler	•	•	•	•	•	•
LiDAT, vehicle fleet management	•	•	•	•	•	•
Proportional control	•	•	•	•	•	•
Radio Comfort, control via display with handsfree set	+ +	+ +	+ +	+ +	+ +	+ +
Preparation for radio installation	•	•	•	•	•	•
Amber beacon, on cab, LED double flash	+ +	+ +	+ +	+ +	+ +	+ +
Windows made from impact-resistant laminated safety glass (front, roof and bottom window)	•	•	•	•	•	•
Windscreen wiper, roof	+ +	+ +	+ +	+ +	+ +	+ +
Windshield wiper, entire windshield	•	•	•	•	•	•
FOPS top guard	+ +	+ +	+ +	+ +	+ +	+ +
FGPS front guard	+ +	+ +	+ +	+ +	+ +	+ +
Auxiliary heater programmable	•	•	•	•	•	•



Equipment

	150 M	150 C	150 M HR	150 C HR	150 M Gantry	150 C Gantry
Boom lights, 2 pieces, LED	•	•	•	•	•	•
Stick lights, 4 pieces, LED	•	•	•	•	•	•
Boom shutoff (retract / extend), electronically	•	•	•	•	•	•
Equipment with electro-hydraulic end position control	•	•	•	•	•	•
AutoLift	+ +	+ +	+ +	+ +	+ +	+ +
Pressure warning mechanism hoist cylinder	•	•	•	•	•	•
ERC system	•	•	•	•	•	•
Boom cylinder cushioning	•	•	•	•	•	•
Stick camera (with separate monitor), bottom side, with protection	+ +	+ +	+ +	+ +	+ +	+ +
Load torque limitation	+ +	+ +	+ +	+ +	+ +	+ +
Pipe fracture safety valves hoist cylinders	•	•	•	•	•	•
Pipe fracture safety valves stick cylinders	•	•	•	•	•	•
Quick coupling system MH 110B	+ +	+ +	+ +	+ +	+ +	+ +
Protection for piston rod, energy recovering cylinder	+ +	+ +	+ +	+ +	+ +	+ +
Protection for piston rods, hoist cylinder	+ +	+ +	+ +	+ +	+ +	+ +
Stick shutoff (retract), electronically	•	•	•	•	•	•
Stick shutoff (retract / extend), electronically	+ +	+ +	+ +	+ +	+ +	+ +
Retract stick without pressure	•	•	•	•	•	•
Sticks with quick coupling	+ +	+ +	+ +	+ +	+ +	+ +
Overload warning device	+ +	+ +	+ +	+ +	+ +	+ +



Complete machine

	150 M	150 C	150 M HR	150 C HR	150 M Gantry	150 C Gantry
Lubrication						
Central lubrication system for uppercarriage and equipment, automatically	•	•	•	•	•	•
Central lubrication system for undercarriage, automatically	•	•	•	•	•	•
Special coating						
Special coating, variants	+ +	+ +	+ +	+ +	+ +	+ +
Monitoring						
Rear view monitoring with camera	•	•	•	•	•	•
Side view monitoring with camera	•	•	•	•	•	•

- = Standard, + = Option

Options and /or special equipment, supplied by vendors other than Liebherr, are only to be installed with the knowledge and approval of Liebherr in order to retain warranty.

The Liebherr Group

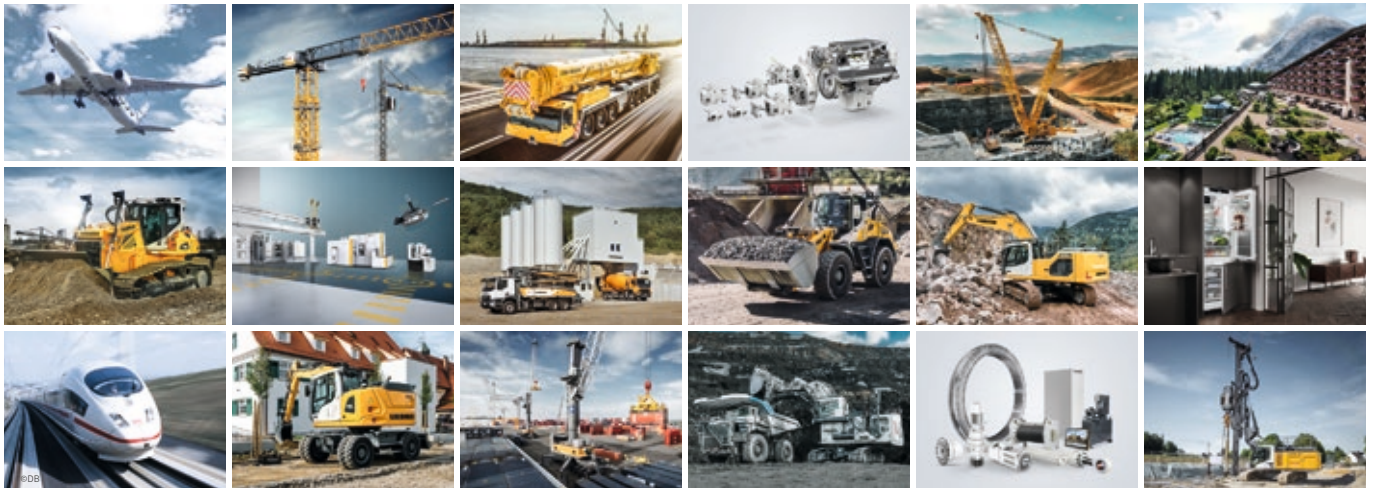

Global and independent: more than 70 years of success

Liebherr was founded in 1949. With the development of the world's first mobile tower crane, Hans Liebherr laid the foundations of a successful family business which today comprises more than 140 companies on all continent and employs nearly 50,000 people. The parent company of the Group is Liebherr-International AG in Bulle (Switzerland), whose associates are exclusively members of the Liebherr family.

Technology leadership and pioneering spirit

Liebherr regards itself as a pioneer. This spirit has enabled the company to make a decisive contribution to the technological history of many industries. Today, employees around the world still share the courage of the company founder to take new paths. They are all united by a passion for technology and fascinating products and the determination to perform outstanding work for their customers.

Widely diversified product portfolio

Not only is Liebherr one of the biggest construction equipment manufacturers in the world, it also provides high-quality, user-oriented products and services in a wide range of other areas. The product portfolio includes the segments earthmoving, material handling technology, deep foundation machines, mining, mobile and crawler cranes, tower cranes, concrete technology, maritime cranes, aerospace and transportation systems, gear technology and automation systems, refrigeration and freezing, components and hotels.

Customized solutions and maximum customer benefit

Liebherr solutions are characterized by maximum precision, outstanding implementation and exceptional longevity. Its mastery of key technologies enables the company to offer its customers customized solutions. For Liebherr, customer focus does not end with the product; it also encompasses a wide range of services that make a real difference.

www.liebherr.us

WARNING

Breathing diesel engine exhaust exposes you to chemicals known to the State of California to cause cancer and birth defects or other reproductive harm.

- Always start and operate the engine in a well-ventilated area.
- If in an enclosed area, vent the exhaust to the outside.
- Do not modify or tamper with exhaust system.
- Do not idle the engine except as necessary.

For more information go to www.P65warnings.ca.gov/diesel.

WARNING

This product can expose you to chemicals including lead and lead compounds, which are known to the State of California to cause cancer and birth defects or other reproductive harm.

For more information go to www.P65warnings.ca.gov.

Liebherr USA, Co.

Construction Equipment Division • 4800 Chestnut Avenue • Newport News, VA 23607, USA • Phone +1 (757) 240 4250
construction.usa@liebherr.com • www.liebherr.us • www.facebook.com/LiebherrConstruction